

Hydrogen and Fuel Cell Activities at CA Airports

DOE FCTO H2@Airports Workshop
November 4-6, 2020

Leslie Goodbody

Air Resources Engineer
leslie.goodbody@arb.ca.gov



California's Key Policy Drivers

- Climate change targets
 - 2020: Achieve 1990 GHG levels
 - 2030: 40% below 1990 levels
 - 2045: Carbon neutrality
 - 2050: 80% below 1990 levels
- Air Quality Goals – South Coast and SJV
 - 2023: 80 ppb 8-hour ozone
 - 2025: 12 mg/m³ 24-hour PM_{2.5}
 - 2031: 75 ppb 8-hour ozone
 - 2037: 70 ppb 8-hour ozone
- New ZEV milestones – [EO N-79-202](#)
 - 2035: 100% new LD sales are ZEVs
 - 2035: 100% of drayage trucks and off-road equipment are ZEVs
 - 2045: 100% of MD/HD vehicles are ZEVs

California GHG Emissions (2017)

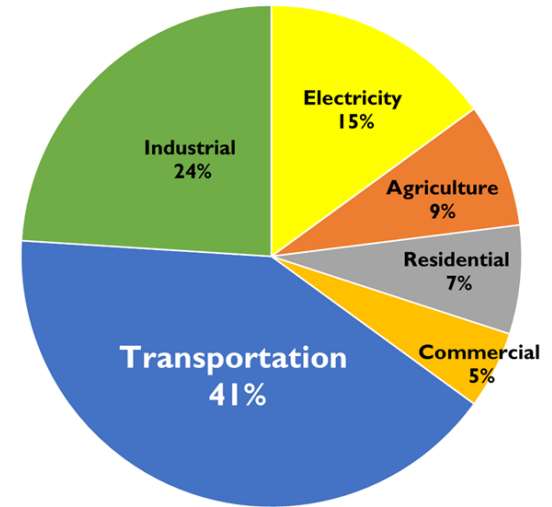

California NO_x Emissions (2017)

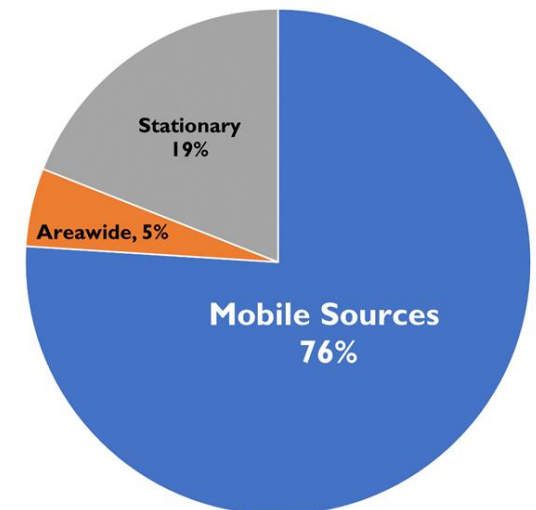

Suite of Mobile Source Regulations

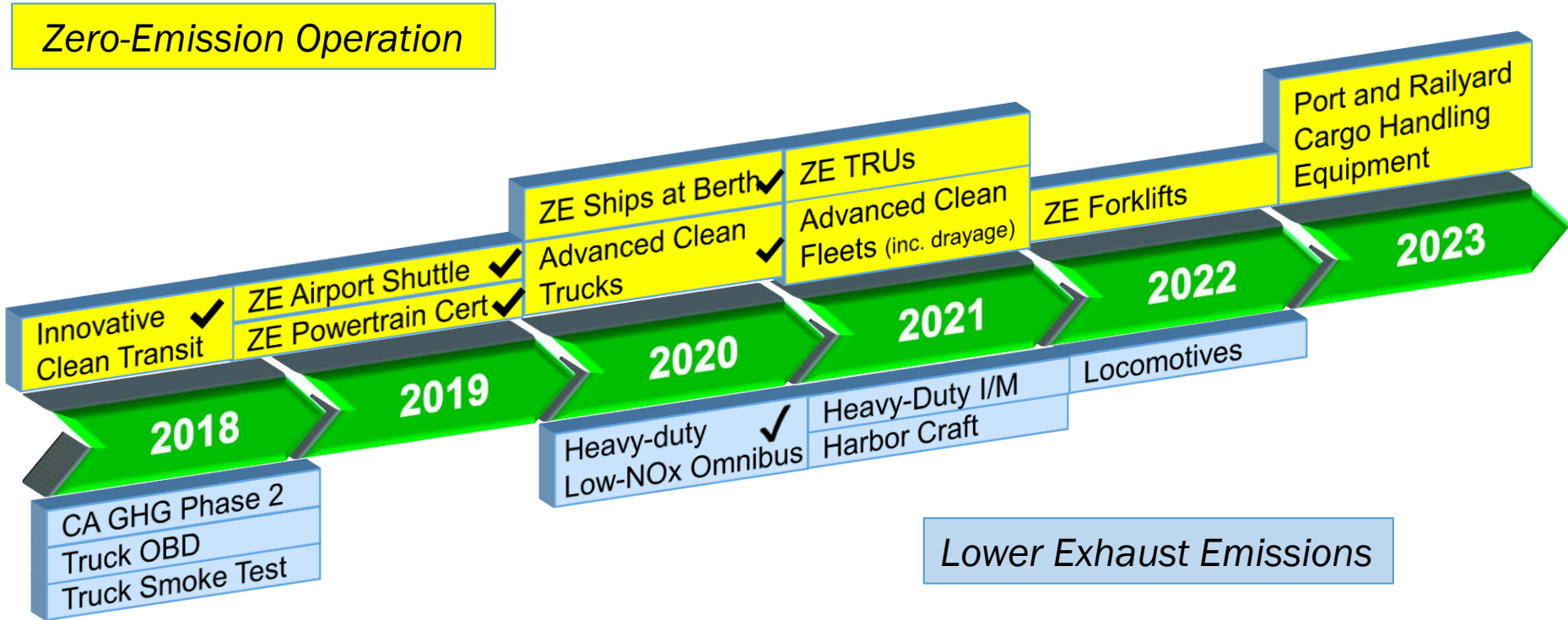

Relevant Regulations

Zero-Emission Transit, Shuttle Bus and Powertrains

Innovative Clean Transit – fleet requirement

- Large agencies: 25% of annual new bus purchase must be ZEBs starting 2023; All agencies 100% by 2029
- Early purchase counts toward future compliance
- ZEB Roll-Out Plans due June 2020 for large, June 2023 for small
- <https://arb.ca.gov/msprog/ict/ict.htm>



Zero-Emission Airport Shuttle – fleet requirement

- Phased in fleet turn-over beginning in 2027 (33%)
- Full implementation in 2035
- 2022- Annual fleet reporting
- <https://ww2.arb.ca.gov/our-work/programs/zero-emission-airport-shuttle>

Zero-Emission Powertrain Certification

- Optional certification for ZE HD powertrains and vehicles
- Includes warranty and reparability provisions
- Required for ZE Shuttle bus and Advanced Clean Trucks MY 2024
- <https://ww2.arb.ca.gov/our-work/programs/zero-emission-powertrain-certification>

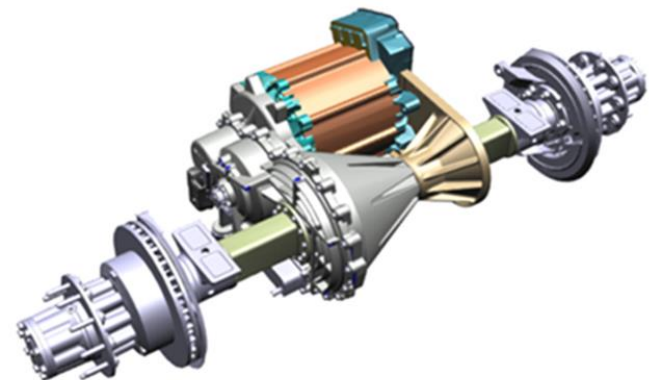

Relevant Regulations

Zero-Emission Trucks and Fleet Rules

Advanced Clean Trucks Regulation

- Manufacturer production requirements for Class 2b-8 trucks
- Starts with MY2024
- Credit/deficit system
- One-time fleet reporting
- <https://ww2.arb.ca.gov/our-work/programs/advanced-clean-trucks>



Zero-Emission Fleet Rules – Pending

- Take steps to achieve full transition to zero-emission
 - 2035 – Drayage trucks at ports and railyards, last mile delivery, government fleets
 - 2040 – Refuse trucks, buses, and utility fleets
 - 2045 – For all other vehicles where feasible
- Considering purchase requirements, fleet standards, green contracting and ZE zones

South Coast AQMD Commercial Airports MOUs

- Voluntary agreements based on each airport's AQIP
- MOUs with LAX, SNA, BUR, ONT and LGB
- Airports will implement measures including:
 - GSE fleet average emission reductions
 - Replacing airport-owned and operated buses with ZEVs
 - Parking and shuttle bus electrification
 - Installing jet fuel pipeline to eliminate fuel delivery trucks
- Airports report annually to South Coast AQMD
- District quantifies SIP creditable emission reductions
 - Provides federally enforceable commitments and report emission reduction benefits to U.S. EPA
 - Seek to obtain SIP credits for the measures specified in the MOUs
 - www.aqmd.gov/airportsmous



Incentive Programs

Demonstration Projects

Fuel Cell Hybrid Electric Delivery Van

- Funding: \$4.3M grant, \$9.5M total
- UPS in Ontario and surrounding areas
- 15 FC hybrid delivery vans
 - Retrofitting existing UPS vans
 - Based on prototype built in partnership with DOE and California Energy Commission
 - Hydrogenics 30kw fuel cell engines
 - Integration design by Unique Electric Solutions
 - Production builds by W.W. Williams in Nevada
- Goal: develop & commercialize fuel cell retrofit kit
- Complete: Early 2022



The University of Texas at Austin
Center for Electromechanics

HYDROGENICS
SHIFT POWER | ENERGIZE YOUR WORLD



W.W. Williams
CONSIDER IT DONE.



Demonstration Projects

Next Generation Fuel Cell Delivery Van

- Funding: \$5.8M grant, \$11.7M total
- UPS in Ontario and surrounding areas
- 4 FC hybrid electric delivery vans
 - Linamar - Gen 2.0 eAxle design & build eAxle
 - Ballard - 85kw fuel cell engines
 - Roush – integrate FC propulsion system into new Ford F-59 chassis
- Goal: develop & commercialize fuel cell retrofit kit
- Complete: Fall 2021



Clean Technology Vouchers

HVIP and CORE

Hybrid and Zero-Emission Truck and Bus Voucher Incentive Project (HVIP)

- Established in 2010: 9,500 vouchers and \$510M
- HVIP-Eligible on-road HD vehicles
 - Transit, school and shuttle buses; utility, delivery, and class 8 trucks
 - Battery electric, fuel cell electric, hybrid, low Nox, ePTO
 - 30 OEMs and 130 models
- Closed Nov. 2019 after funds exhausted
- www.CaliforniaHVIP.org



Clean Off-Road Equipment Voucher Incentive Project (CORE)

- Launched in February 2020: 316 vouchers and \$41M
- Zero-emission airport cargo loaders, aircraft tugs, aircraft ground power units
- Funds exhausted in 6 months
- www.CaliforniaCORE.org



Volkswagen Environmental Mitigation Trust

California's allocation: **\$423 million** for NOx mitigation

Beneficiary Mitigation Plan details 5 funding categories:

1. **\$130M** for Zero-emission transit, school and shuttle buses
Admin statewide by SJVAPCD vwbusmoney.valleyair.org/
 2. **\$60M** for Combustion freight and marine
Admin by statewide by SCAQMD www.aqmd.gov/vw
 3. **\$90M** for Zero-emission Class 8 freight and port drayage trucks
Admin statewide by SCAQMD www.aqmd.gov/vw
 4. **\$70M** for Zero-emission freight and marine equipment
Admin statewide by BAAQMD www.californiavwtrust.org/
 5. **\$10M** for charging and hydrogen infrastructure for LDVs
Admin statewide By BAAQMD www.californiavwtrust.org/
- All funding released in at least 2 instalments, except light duty infrastructure



CARB's VW Mitigation Trust website
ww2.arb.ca.gov/vwmitigationtrust





Questions?

Leslie.Goodbody@arb.ca.gov

Engineer, Innovative Heavy Duty Strategies
Mobile Source Control Division