

Hydrogen-Electric Transport Aircraft System Technologies

P. Ansell

University of Illinois at Urbana-Champaign

Urbana, IL

November 5, 2020

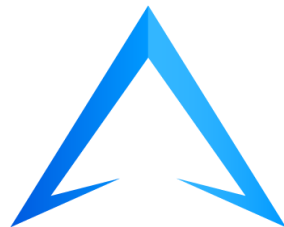

CHEETA

Center for High-Efficiency Electrical
Technologies for Aircraft

Introductions



Our Team

- CHEETA
 - Established in 2019 under a \$6M NASA ULI program
 - Led by the University of Illinois at Urbana-Champaign
- Bringing together world experts in
 - Aeronautics
 - Electrical Systems
 - Material Science
- Multi-institutional
 - 7 Universities
 - 2 Industry groups
 - Government research collaboration

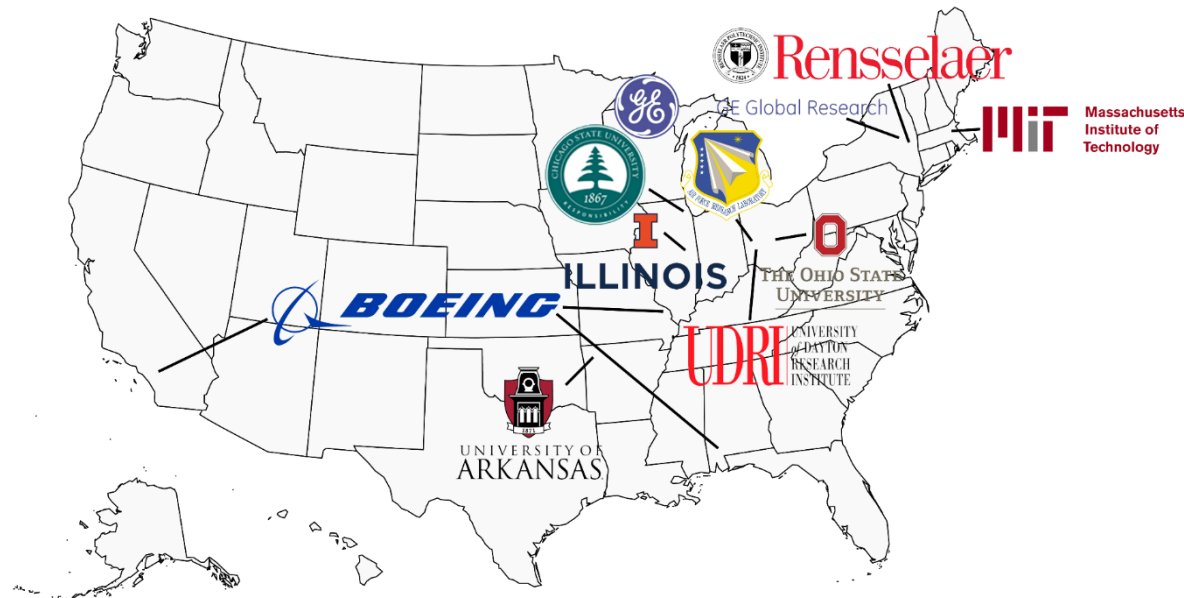

CHEETA Goals

- Develop, mature, and design disruptive technologies for electric commercial aviation
 - Distributed propulsion and high-efficiency electrical power conversion
 - High-power, flight-weight cryogenic electric machines and power electronics
 - Materials and systems for superconducting high-power transmission and large current density
 - Integration and optimization of unconventional and complex aircraft systems
- Motivate and train the next-generation of professional engineers through engaging outreach

Why Electric Aircraft?

- Global aviation industry produces over 900 million metric tons of CO₂ per year^[1]
- Forecasted 4-5% growth rate in air travel per year^[2]
- Transportation is the leading source of greenhouse gas emissions in the US^[3]
 - Aircraft make up ~10% of this contribution
- Technology improvements in flight efficiency lag growth (net 64% increase in aviation CO₂ by 2050)

Global Civil Aviation Fuel Consumption

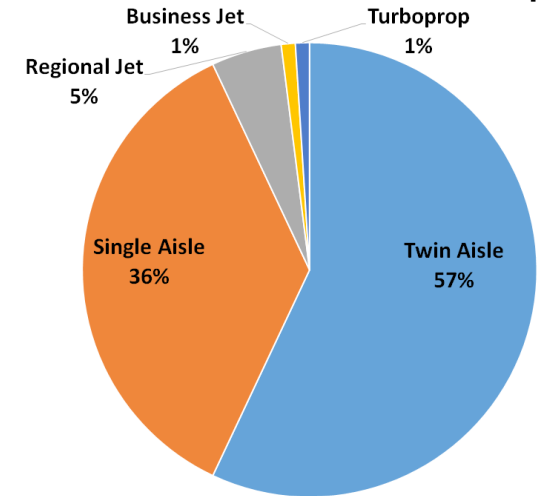

Yutko and Hansman (2011)

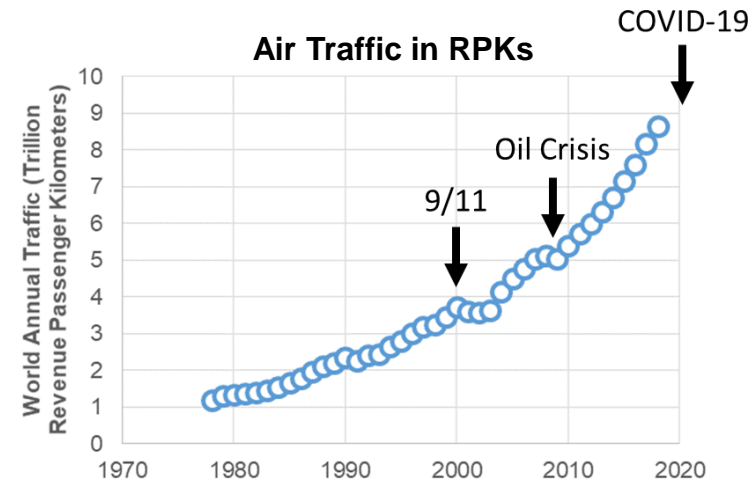

Ansell and Haran (2020)

5

Implementation Challenges: Components

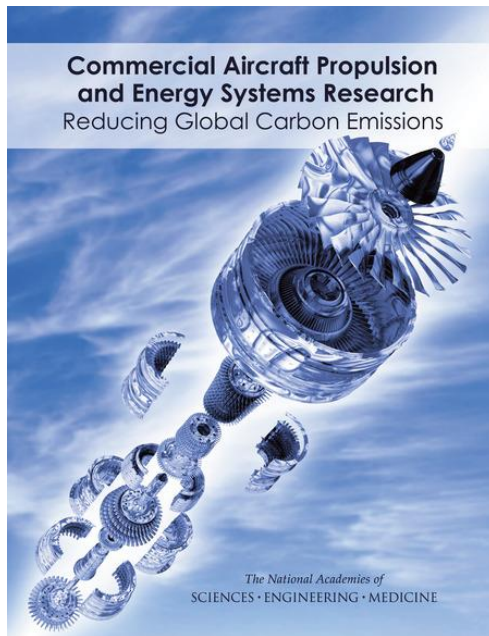

TABLE 4.2 Electrical System Component Performance Requirements for Parallel Hybrid, All-Electric, and Turboelectric Propulsion Systems

Aircraft Requirements	Electric System ^a		Battery ^b
	Power Capability (MW)	Specific Power (kW/kg) ^c	Specific Energy (Wh/kg)
General aviation and commuter			
Parallel hybrid	Motor <1	>3	>250
All-electric	Motor <1	>6.5	>400
Turboelectric	Motor and generator <1	>6.5	n/a
Regional and single-aisle			
Parallel hybrid	Motor 1-6	>3	>800
All-electric ^b	Motor 1-11	>6.5	>1,800
Turboelectric	Motor 1.5-3 generator 1-11	>6.5	n/a
Twin-aisle			
Parallel hybrid	Not studied	Current (non-cryo): 0.25 MW [B787 Generator]	Current: 250 Wh/kg [Tesla Li-Ion]
All-electric	Not feasible		
Turboelectric	Motor 4; generator 30	>10	n/a
APU for large aircraft			
	Generator 0.5-1	>3	Not studied

^a Includes power electronics.

^b Total battery system and usable energy for discharge durations that are relevant to commercial aviation flight times, nominally 1-10 hours. Values shown are for rechargeable batteries; primary (nonrechargeable) batteries are not considered relevant to commercial aviation.

^c Conversion factors: 1 kW/kg = 0.61 HP/lb; 1 kg/kW = 2.2 lb/kW = 1.64 lb/HP.

National Academies (2016)

Implementation Challenges: Energy Storage

Battery Specific Energy Development (Cell Level)

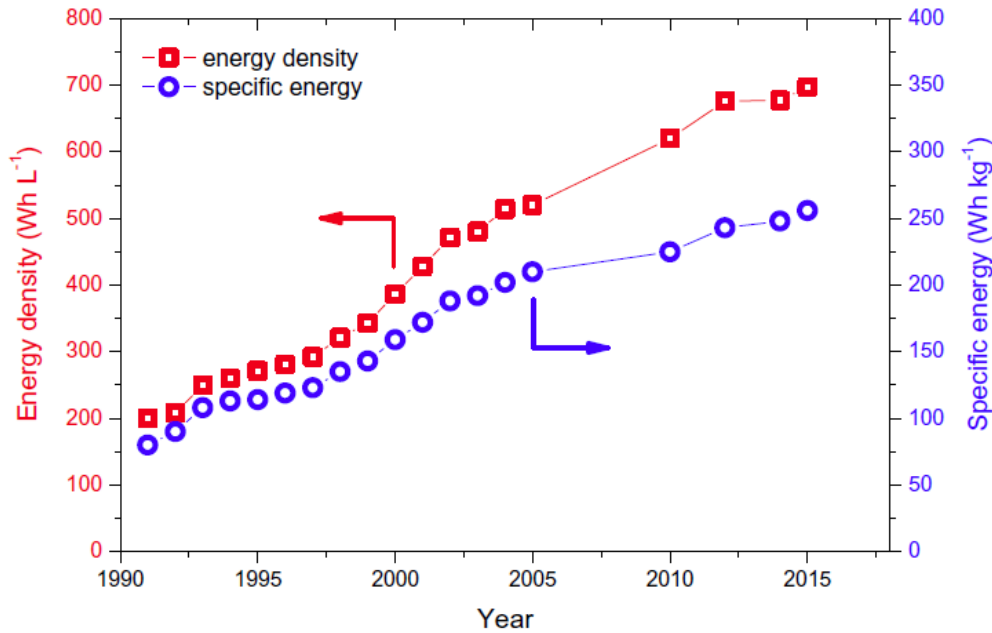

Placke et al. (2017)

Boeing 737-700 Hybrid-Electric Range

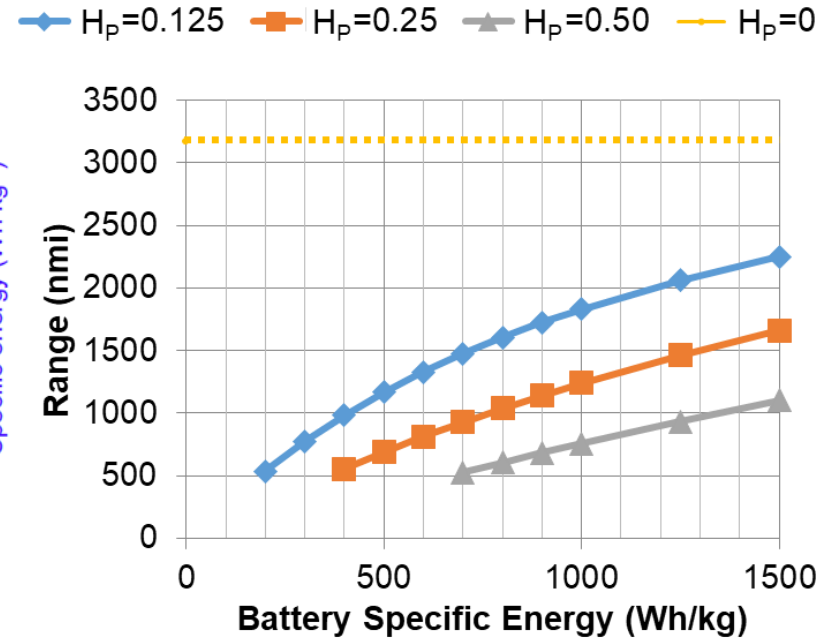

Wroblewski and Ansell (2018)

Implementation Challenges: Configuration

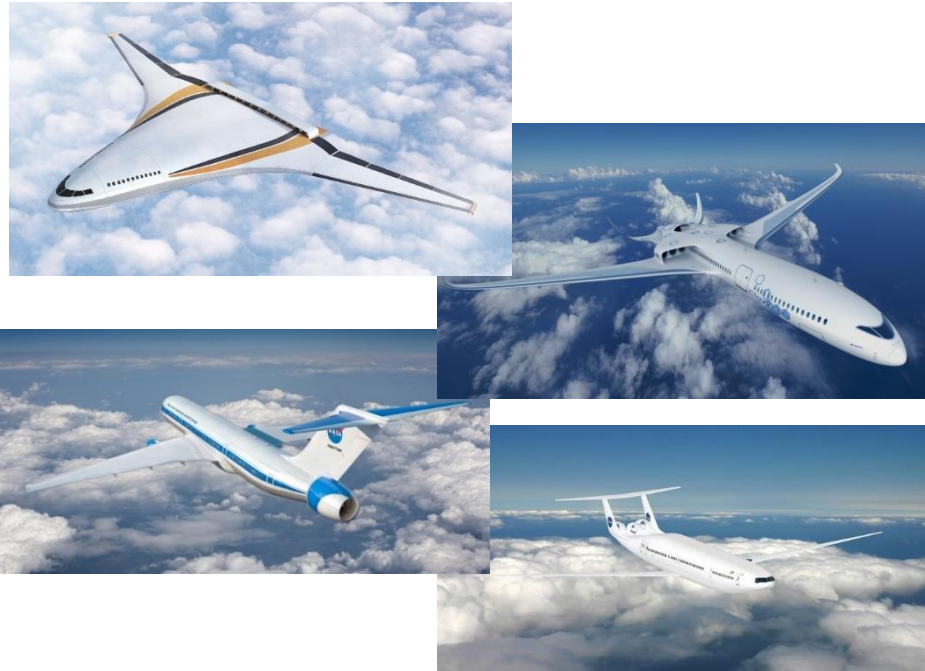
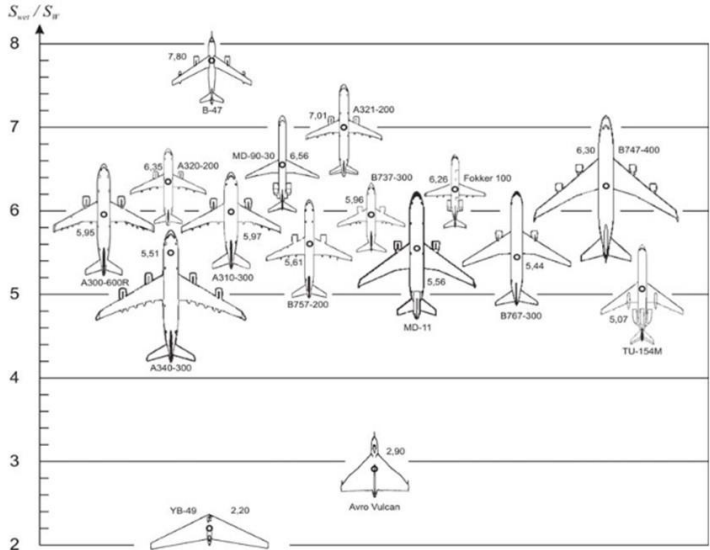

Hydrogen as an Energy Carrier

- Liquid Hydrogen (LH₂)
 - Specific energy 700× that of batteries (3× Jet A)
 - Liquid state ~20K, with 1/4 energy density of Jet A
 - Abundance of H₂, improvements in economic viability with time
 - Ability to produce/supply on-site
- Fuel Cells
 - Specific power increase from 0.3 kW/kg to 3.73 kW/kg^[4] over previous 15 years
 - Large improvements in specific power forecast at fuel cell stack-level^[5]
- Environmental
 - Zero CO₂, CO, NO_x, SO_x, partially-combusted hydrocarbons, particulate matter

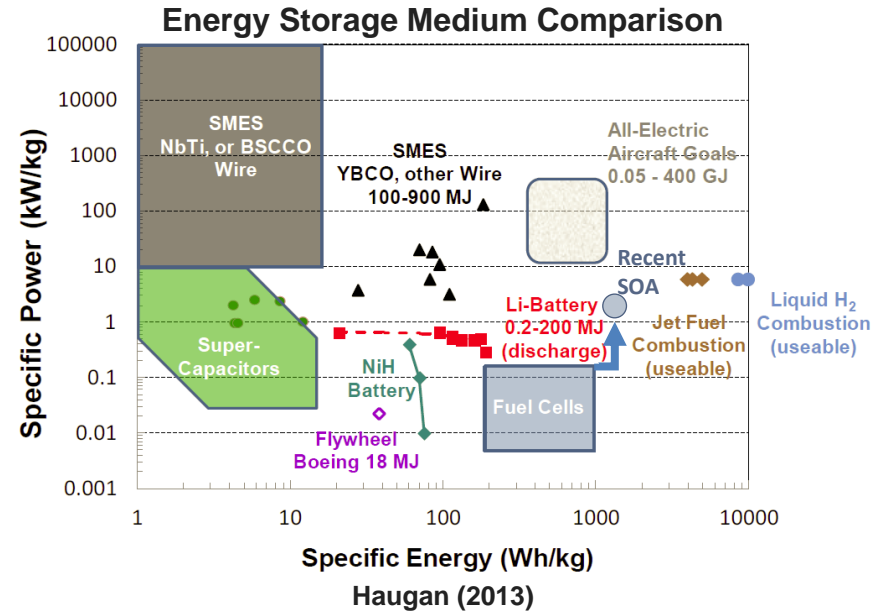

Table 1. Rated Power Performance of FCS with SOA Alloy Catalysts

Stack Parameters	2018 FCS with d-PtCo/C Catalyst	2017 FCS with d-PtNi/C Catalyst
Membrane	Ionomer: 850 EW PFSA with chemical additive Substrate: Mechanical reinforcement Thickness: 14 μm	Ionomer: 850 EW PFSA with chemical additive Substrate: Mechanical reinforcement Thickness: 14 μm
Cathode Catalyst	d-Pt ₃ Co/C (0.1 mg _{Pt} /cm ²), EW=950, I/C=1.0	Electrode: d-PtNi ₃ (0.1 mg _{Pt} /cm ²), acid washed Ink: organic, EW=850, I/C=1.0
Anode Catalyst	Pt/C (0.025 mg _{Pt} /cm ²)	Pt/C (0.025 mg _{Pt} /cm ²)
Stack Gross Power	88.5 kW	88.1 kW
Stack Voltage (Rated)	250 V	250 V
Number of Active Cells	380 cells (also 381 cooling cells)	377 cells (also 376 cooling cells)
Stack Gross Power Density	3.07 kW/L	2.84 kW/L
Stack Gross Specific Power	3.73 kW/kg	3.45 kW/kg
Stack Inlet Pressure	2.5 bar	2.5 bar

DOE/GO-102019-5156 (2019)

^[4] 2018 FCS with d-PtCo/C Catalyst, DOE/GO-102019-5156

^[5] Kadyk et al. (2018)

LH₂ Superconducting Power System

- Dual-Use H₂ Configuration
 - Hydrogen as an energy carrier *and* as a cryogen, enabling superconducting system
- Superconducting Power Transmission
 - No ohmic losses
 - Lower transmission voltage (mitigates breakdown/partial discharge challenges)
 - Smaller, lightweight conductors
- Cryogenic machines
 - Ultra-high efficiency (superconducting wire)
 - Large current density and small conductor size for very high rated and specific power

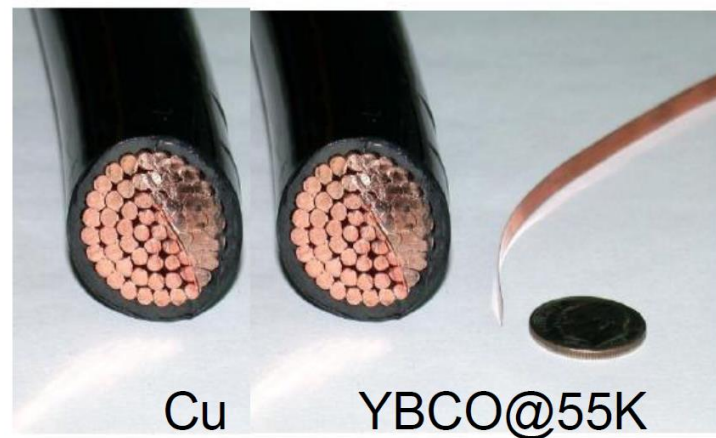
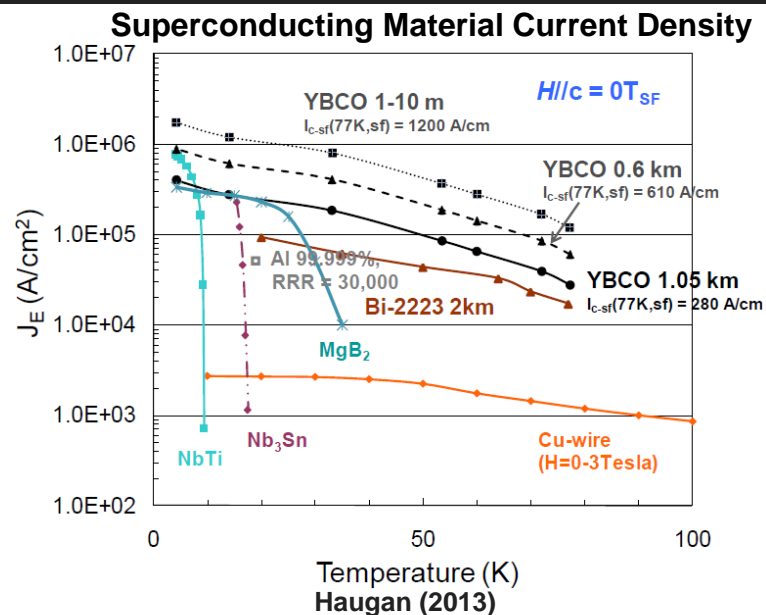

Hydrogen-Electric Aircraft Configuration

- Assume entry-into-service ~2050
 - Technology development concept
- Aircraft Platform
 - High-volume energy storage requirement
- Distributed Electric Propulsion
 - Flexibility in placement and configuration of propulsors enables
 - Boundary-layer ingestion (improves in system efficiency)
 - Improved high-lift performance
 - Resilience against propulsor-out scenarios (OEI)
- System Integration
 - Electrical, thermal system architecture and control
 - Design optimization of aircraft

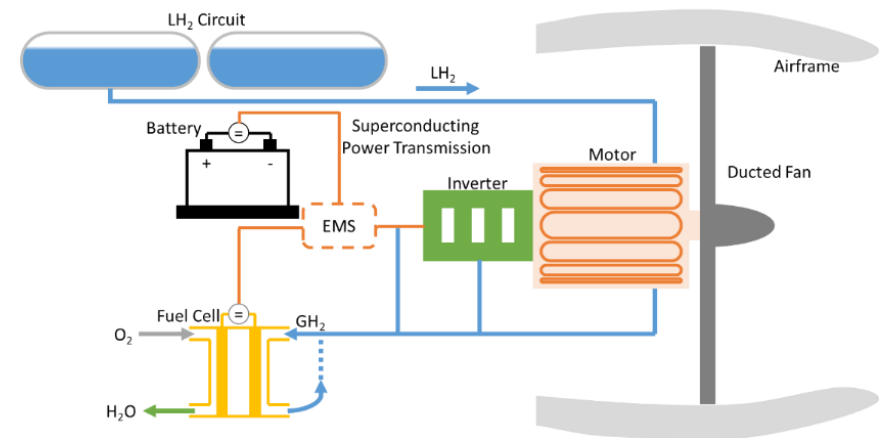
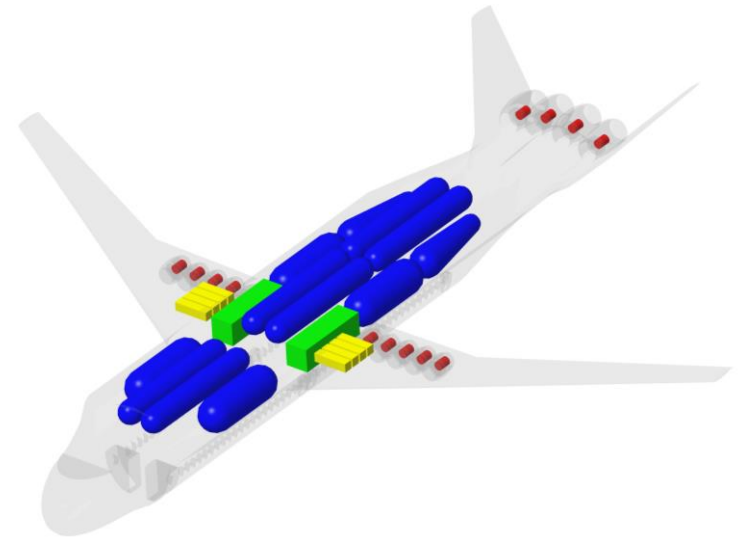

ULI Study Components

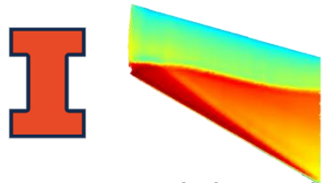

Aero-structural-thermal design optimization

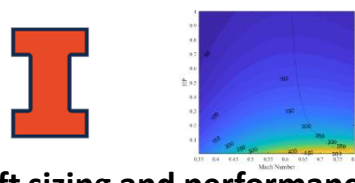

Aircraft sizing and performance



Integrated aero-propulsive system

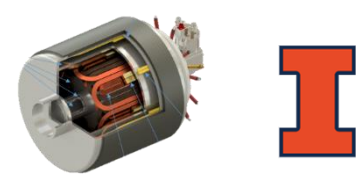

Superconducting machine design and quench dynamics

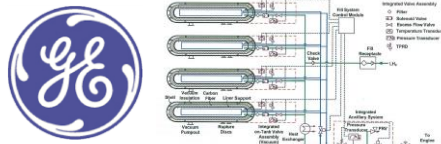

Cryogenic energy systems

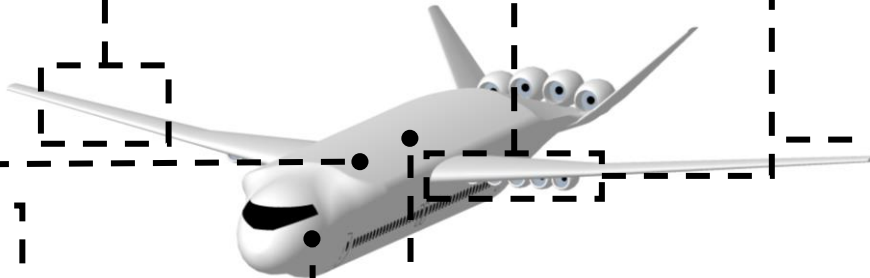

UNIVERSITY OF ARKANSAS



Cryogenic motor drive and cryo-cooled electronics



Multi-domain aircraft system modeling



Power system integration



Superconducting materials

Research Needs

- Fuel cell specific power
 - Not yet competitive with gas turbines at system level
 - Further hindered by thermal management (PEM) and other BOP
- Stack gross power
 - 10's to 100's of MW power required
- Lightweight tanks
- High-temperature PEM and other lower-TRL systems
 - Attractive means for thermal challenges of LT-PEM
 - Increase current density and specific power
- System integration impacts
 - Close loop between hydrogen and fuel cell advances and aircraft system performance
- Support infrastructure
 - Even if aircraft system is viable, what else does it take?

Transportation Power and Energy Required

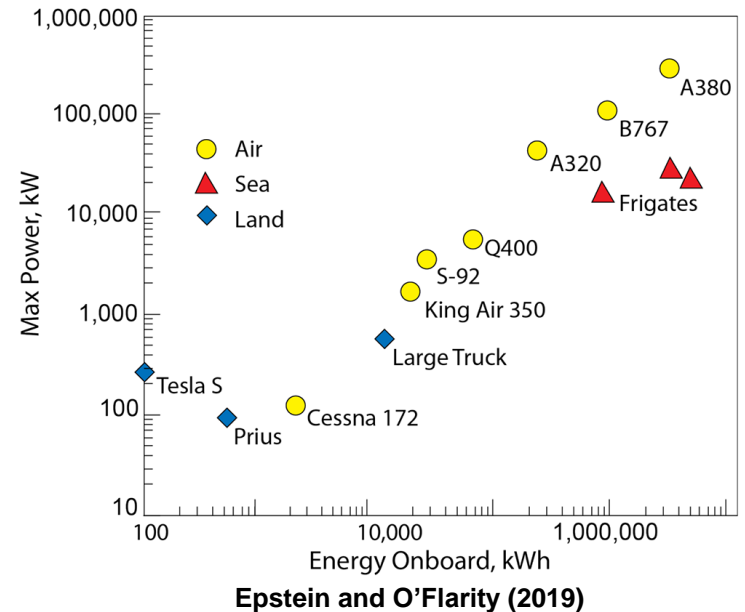

Hybrid-Electric Commercial Transport CO₂ Impact

