

U.S. DEPARTMENT OF
ENERGY

Office of
**ENERGY EFFICIENCY &
RENEWABLE ENERGY**

Project Icebreaker

T26 DE-EE0005989

Lorry Wagner, Ph.D.

Lake Erie Energy Development Corp. (LEEDCo)



FY17-FY18 Wind Office Project Organization

“Enabling Wind Energy Options Nationwide”

Technology Development

Atmosphere to Electrons

Offshore Wind

Distributed Wind

Testing Infrastructure

Standards Support and International
Engagement

Advanced Components, Reliability, and
Manufacturing

Market Acceleration & Deployment

Stakeholder Engagement, Workforce
Development, and Human Use Considerations

Environmental Research

Grid Integration

Regulatory and Siting

Analysis and Modeling (cross-cutting)

Project Overview

T26: Project Icebreaker

Technology Summary: First-of-a-Kind Advanced Technology Offshore Wind Demonstration Project

Period of Performance: 2016-2020*

*Budget Period 2 of 5

Project Status: The project is currently in budget period 2 of 5 requiring the completion of the following criteria:

- 1) Complete Front-End Engineering Design
- 2) Complete Installation and Operations and Maintenance Plans
- 3) Complete all necessary federal and state permitting processes
- 4) Complete all grid interconnection agreements and finalize power off-take agreements

Technology Impact: Reduce the levelized cost of energy (LCOE) through technology development and reduced deployment timelines and uncertainty

Project Goals: Deploy an innovative offshore wind foundation technology - **Monobucket (MB)** - that will eliminate pile driving, minimize noise, and subsequently lower the cost of energy; reduce market barriers associated with siting and permitting; develop a robust supply chain that will support future development and innovation

Partners: Fred. Olsen Renewables, DNV GL, Universal Foundation, Jacobs Engineering, Offshore Design Engineering, EDR, Green Giraffe, KPMG, Cleveland Public Power, Dickinson Wright, LimnoTech, Western Ecosystems Technology, Natural Power, Fred. Olsen Windcarrier, U.S. Army Corps of Engineers Cold Regions Research Laboratory, Allyn & Croasdale, Case Western Reserve University

Project Overview Continued

6 Vestas V126-3.45 turbines

8 – 10 miles offshore

Water depth \approx 60 feet

20.7 MW capacity

Power for 7,000 homes

Mono Bucket foundations

Grid connection at CPP
Lake Road substation

Port of Cleveland
staging & assembly site

Local Power Subscription



Technical Merit: Innovative Technology

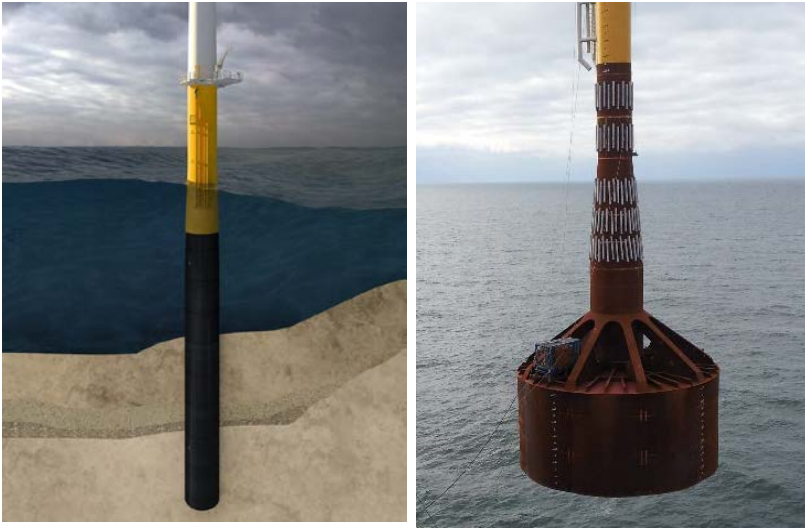

Why demonstrate the Mono Bucket?

- Noiseless installation
- No Pile Driving
- Great Lakes & OCS Soils
- Similarities of the North Sea & Lake Erie
- Ability to utilize U.S. Manufacturing

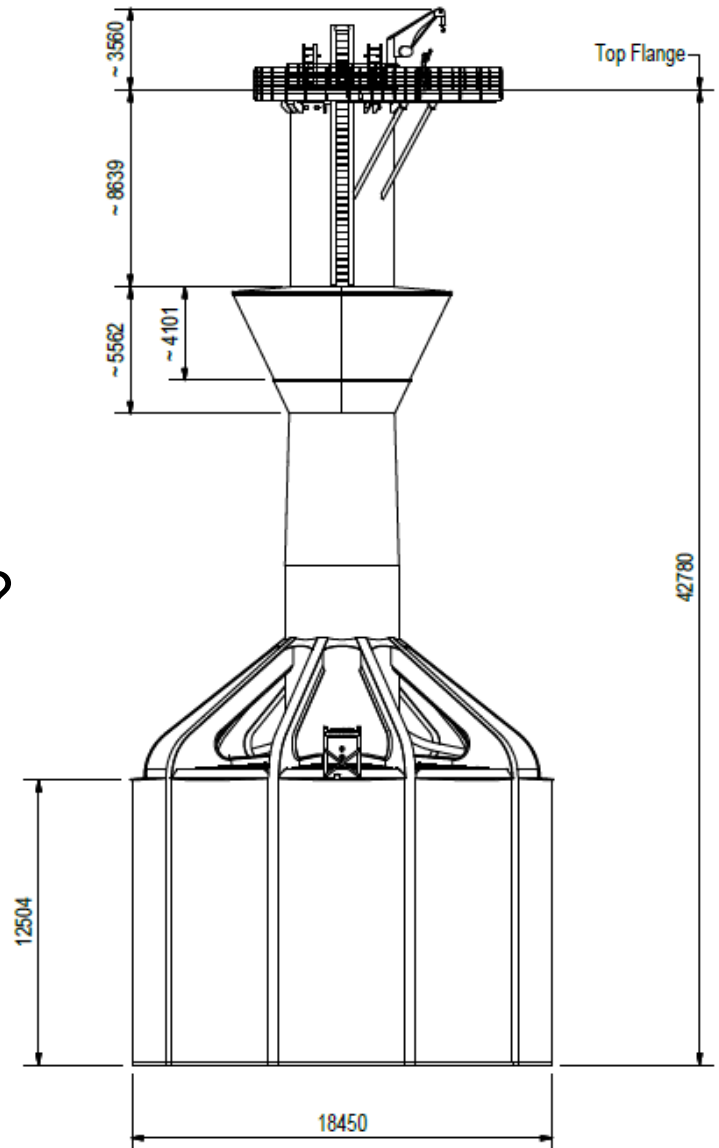

Technical Merit: Projected Cost Reductions

The Impact

Reduces Balance-of-System (BOS) CAPEX, Substructure Costs

- Introduces an innovative but proven (TRL7) new foundation type to the U.S. market: the Mono Bucket
- For Icebreaker Wind – Reduces capex of the foundation by 33%
- For East coast markets – reduces capex of the foundations by 10–30%, depending on soil conditions & water depth

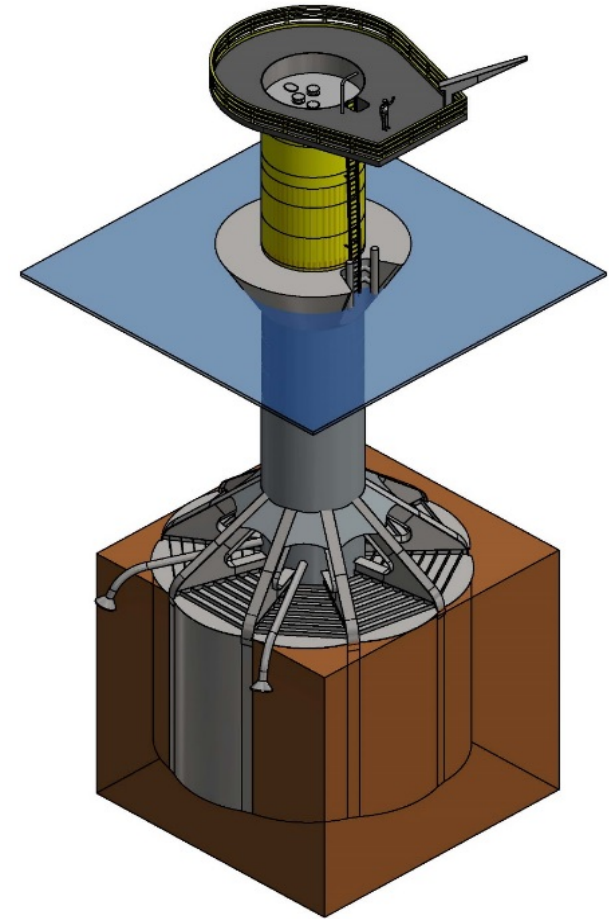

Technical Merit: Breaking Down Barriers



State Agencies Federal Agencies

Accomplishments: Permitting

		DESCRIPTION	AGENCY	DATES (bold = actual date)		STATUS
				SUBMIT	OBTAIN	
1		Submerged Lands Lease	ODNR	3-Sep-2013	1-Feb-2014	Lease Obtained
2		Certificate of Environmental Compatibility and Public Need	OPSB	1-Feb-2017	31-May-2019	Pending ✓
3		Finding of No Significant Impact (FONSI) [NEPA Environmental Assessment- EA]	DOE, USACE, USCG	18-Aug-2017	2-Oct-2018	Permit Obtained ✓
4		Clean Water Act Section 404/Rivers and Harbors Act Section 10 Permit	USACE	25-Aug-2017	1-Mar-2019	Permit Obtained ✓
5		Water Quality Certification Section 401	OEPA	17-Oct-2017	26-Jul-2018	Permit Obtained ✓
6		Federal Navigation Project Section 408	USACE	1-Feb-2017	8-Sep-2017	Permit Obtained ✓
7		Permit for Private Aid to Navigation Form 2554	USCG	1-Mar-2019	30-Jun-2019	
8		Determination of No Hazard to Air Navigation	FAA	22-Jul-2016	22-Feb-2017	Permit Obtained ✓
9		Letter of Concurrence that Project does not Impact Water Levels and Ice Flows	US State Department	9-Dec-2016	30-Jun-2017	Permit Obtained ✓

Partners, Subcontractors, and Collaborators:

- **Universal Foundation** – Mono Bucket design engineer;
- **Offshore Design Engineering** – Owners engineer;
- **DNV GL** – CVA; **Fred. Olsen Windcarrier** – Installation engineer;
- **GLWN** – Supply chain development;
- **Case Western Reserve Univ.** – Research;
- **USACE CRREL** – Ice research