

## 7.0 PLANNED DECOMMISSIONING ACTIVITIES

### PURPOSE OF THIS SECTION

The purpose of this section is to describe the Phase 1 decommissioning activities.

### INFORMATION IN THIS SECTION

This section provides the following information:

- In Section 7.1, a brief summary of site conditions expected at the beginning of the Phase 1 decommissioning activities;
- In Section 7.2, a summary of the general approach and the general requirements that apply to the decommissioning activities;
- In Sections 7.3 through 7.11, descriptions of the Phase 1 decommissioning activities;
- In Section 7.12, a summary of the types of remediation and demolition technologies to be employed; and
- In Section 7.13, a discussion of the conceptual project schedule.

### RELATIONSHIP TO OTHER PLAN SECTIONS

To put into perspective the information in this section, one must consider the information in Section 1 on the project background and those facilities and areas within the scope of the plan, Section 2 on facility operating history, and Section 3 that describes the facilities at the WVDP. One should also consider the radiological status information presented in Section 4.

The activities described here will be accomplished in accordance with requirements in other sections, as follows:

- Section 1.6, project management and project organization,
- Section 1.7, radiation safety and monitoring of workers;
- Section 1.8, environmental monitoring and control;
- Section 1.9, radioactive waste management;
- Section 8, quality assurance for engineering design, data, and calculations; for characterization; for engineered barrier installation; and for final status surveys; and
- Section 9, characterization surveys, in-process surveys, and final status surveys.

WVDP PHASE 1 DECOMMISSIONING PLAN

**7.1 Conditions at the Beginning of the Phase 1 Decommissioning Work**

Section 1.10 of this plan describes the interim end state to be reached at the conclusion of WVDP facility deactivation work. Section 4 summarizes the radiological conditions of facilities and areas within the scope of this plan. Table 7-1 notes the expected conditions in each facility or area in the interim end state, i.e., at the beginning of the Phase 1 decommissioning work, based on information provided in Section 2 and Section 4. This table does not address soil and groundwater except in WMA 1 and WMA 2 where large areas will be excavated, **although some surface and subsurface soil contamination is expected to be present in other WMAs.**

**Table 7-1. Facility and Area Conditions Expected at the Beginning of Phase 1<sup>(1)</sup>**

WMA	Facility/Area	Conditions (See legend at table's end for acronyms)
1	Process Building	Partially decontaminated, high radiation levels in some cells, vitrified HLW canisters in the HLW Interim Storage Facility, CSRF removed.
	Vitrification Facility	Partially decontaminated, high radiation levels in Vitrification Cell.
	01-14 Building	Significant contamination in filters, portion of off-gas line in building <sup>(2)</sup> .
	Vitrification off-gas line	Significant residual radioactivity.
	Utility Room	No contamination above MDC in most areas.
	Utility Room Expansion	No contamination above MDC in most areas.
	Load-In/Load-Out Facility	No contamination above MDC in most areas.
	Plant Office Building	No contamination above MDC.
	Fire Pump House	Not impacted by radioactivity.
	Water Storage Tank	Not impacted by radioactivity.
	Electrical Substation	Not impacted by radioactivity.
	Underground tanks	Significant contamination in Tank 7D-13, little in others.
	Underground lines	Significant contamination in some lines, especially 7P120-3.
	Subsurface soil, groundwater	Significant contamination in plume source area under the Process Building
	Surface soil	Low-level contamination may be present in several areas.
2	Lagoon 1	Deactivated, significant radioactivity in sediment.
	Lagoon 2	In use, radioactive water, significant radioactivity in sediment.
	Lagoon 3	In use, radioactive water, low levels of radioactivity in sediment.
	Lagoon 4	In use, radioactive water, low levels of radioactivity in sediment.
	Lagoon 5	In use, radioactive water, low levels of radioactivity in sediment.
	Interceptors	In use, significant contamination in Old Interceptor, less in new ones.
	Neutralization Pit	In use, low-level contamination.
	LLW2 Building	In use, low level contamination, radioactive water in sump.
	Underground lines	Most in use, low-level contamination.
	Solvent Dike	Low-level contamination in soil.
	Subsurface soil, groundwater	Contaminated with Sr-90 in plume area, other subsurface soil contamination.

WVDP PHASE 1 DECOMMISSIONING PLAN

**Table 7-1. Facility and Area Conditions Expected at the Beginning of Phase 1<sup>(1)</sup>**

WMA	Facility/Area	Conditions (See legend at table's end for acronyms)
	Surface soil	Low-level contamination in much of area.
3	Tank 8D-1 <sup>(3)</sup>	Laid up, one HLW transfer pump and five mobilization pumps in place.
	Tank 8D-2 <sup>(3)</sup>	Laid up, one HLW transfer pump and four mobilization pumps in place.
	Tank 8D-3 <sup>(3)</sup>	Laid up, one submersible pump in place.
	Tank 8D-4 <sup>(3)</sup>	Laid up, one submersible pump in place.
	Con-Ed Building	Low levels of residual radioactivity, mostly inside equipment.
	Equipment Shelter	Low levels of residual radioactivity, mostly inside equipment.
	HLW transfer trench	High levels of residual radioactivity inside piping and equipment.
4	Construction and Demolition Debris Landfill	Low level Sr-90 contamination from the north plateau groundwater plume in some buried waste and in other parts of WMA 4. [WMA 4 and the landfill are not within the Phase 1 decommissioning scope.]
5	Lag Storage Addition 4, Shipping Depot	No contamination above MDC.
	RHWF	Low levels of contamination, but may be significant in Work Cell.
6	Sewage Treatment Plant	Not impacted by radioactivity.
	South WTF Test Tower	Not impacted by radioactivity.
	Demineralizer sludge ponds	Low levels of radioactivity in soil.
	Equalization basin	Not impacted by radioactivity.
	Equalization tank	Not impacted by radioactivity.
7	NRC-Licensed Disposal Area (NDA)	Significant radioactivity in buried waste, low-level surface soil contamination. [The NDA is not within the Phase 1 decommissioning scope.]
9	Drum Cell	No contamination above MDC.
10	New Warehouse	Not impacted by radioactivity.

NOTES: (1) See also Table 2-13 in Section 2, which contains information on the radiological status of remaining concrete floor slabs and foundations.

(2) The filters may be removed before Phase 1 begins.

(3) These tanks contain significant amounts of residual radioactivity and the mobilization and transfer pumps are expected to have high radiation levels as indicated in Section 4.1.

LEGEND: CSRF = Contact Size Reduction Facility (former Master-Slave Manipulator Repair Shop)

MDC = minimum detectable concentration

RHWF = Remote-Handled Waste Facility

WTF = Waste Tank Farm

## 7.2 General Approach and General Requirements

### 7.2.1 General Approach

As explained in Section 1, the WVDP decommissioning will be accomplished in two phases. The following activities will take place in Phase 1.

#### Facility and Equipment Removal

The following facilities and equipment will be removed:

## WVDP PHASE 1 DECOMMISSIONING PLAN

- All WMA 1 facilities, including the three underground wastewater tanks and the underground lines;
- In WMA 2, the five lagoons, the Interceptors, the Neutralization Pit, the LLW2 Building, the Solvent Dike, the Maintenance Shop leach field, the remaining concrete slabs and foundations, and the underground wastewater lines within the large excavation;
- In WMA 3, the waste **tank pumps**, the Con-Ed Building, the Equipment Shelter and condensers, and the piping and equipment in the HLW transfer trench;
- In WMA 5, the two remaining structures – Lag Storage Addition 4/**Shipping Depot** and the Remote- Handled Waste Facility – and the remaining concrete floor slabs and foundations;
- In WMA 6, the Sewage Treatment Plant, the south Waste Tank Farm Test Tower, the two demineralizer sludge ponds, the equalization basin, the equalization tank, and the remaining concrete floor slabs and foundations;
- In WMA 7, the remaining gravel pads associated with the NDA hardstand;
- In WMA 9, the Integrated Radwaste Treatment System Drum Cell, the sub-contractor maintenance area, and the trench soil container area; and
- In WMA 10, the New Warehouse.

The following facilities and equipment on the project premises are not within the scope of the Phase 1 decommissioning activities:

- In WMA 2, the North Plateau Pump and Treat System, the Pilot Scale Permeable Treatment Wall, the Full-Scale Permeable Treatment Wall, and underground lines not within the excavated areas;
- In WMA 3, the four underground waste tanks, the Permanent Ventilation System Building, the Supernatant Treatment System Support Building, the HLW transfer trench itself, and the underground lines;
- In WMA 4, the Construction and Demolition Debris **Landfill**;
- In WMA 6, the rail spur;
- In WMA 7, the NDA and the associated interceptor trench; and
- In WMA 10, the Meteorological Tower and the Security Gatehouse.

### Approach

Soil and sediment on the project premises will be characterized for radioactivity. Before the Process Building is removed, the new Canister Interim Storage Facility will be **established** on the south plateau, the Load-In Facility converted to a Load-Out Facility, and vitrified HLW canisters transported to the new Canister Interim Storage Facility.

One large excavation will be dug to remove the WMA 1 facilities and a second large excavation dug to remove key WMA 2 facilities. These excavations will extend down into the underlying Lavery till. Contaminated surface and subsurface soil in these excavations will be removed to achieve **the cleanup goals** for unrestricted release specified in Section

5<sup>1</sup>. The source area of the north plateau groundwater plume in WMA 1 will be removed, but not the non-source area portion of the plume, except for those portions that fall within the large WMA 1 and WMA 2 excavations.

### **Activity Integration**

The work will be sequenced for maximum efficiency. For example, the Low-Level Waste Treatment Facility will be kept in service until the Process Building is taken down so its wastewater treatment capabilities can be utilized during the Process Building decontamination and demolition work. The conceptual schedule in Figure 7-15 describes the general sequence. Section 1.6 describes the more-detailed schedules that will be used in management of the project.

More details will appear in one or more Decommissioning Work Plans, which will be completed before the Phase 1 decommissioning activities begin and will address matters such as demolition of the Process Building and the Vitrification Facility.

### **7.2.2 General Requirements**

The following general requirements will be adhered to during decommissioning activities described in Sections 7.3 through 7.11.

#### **Use of Approved Written Procedures**

Following DOE policy, the decommissioning activities will be accomplished in accordance with written procedures formally approved by the appropriate member(s) of the decommissioning team.

#### **Remedial Technologies**

The decommissioning contractor will utilize efficient, proven technologies in accomplishment of the work. Section 7.12 provides examples of these technologies. DOE has generally avoided being prescriptive in methods to be used to give the decommissioning contractor the flexibility to make use of improved methods that may become available. Exceptions include the conceptual designs for engineered barriers, which are more specifically described because of their **potential** importance in support of Phase 2 of the decommissioning. The Decommissioning Work Plan(s) will provide more-detailed information on remedial technologies to be used.

#### **Dealing With Unique Remediation Issues**

Given the complexities of the site, some remediation issues will be faced during Phase 1 of the WVDP decommissioning that are highly unusual, if not entirely unique. Two such issues are demolition of the Process Building and removal of the radioactive contamination in the source area of the north plateau groundwater plume that extends far below the building.

---

<sup>1</sup> As explained in Section 5, cleanup goals have been established below the DCGLs for unrestricted release to account for combined exposure scenarios that could potentially be encountered if the entire project premises were to be cleaned up to unrestricted release standards in Phase 2 of the decommissioning. The surface soil cleanup goals will be applied from the ground surface to a depth of three feet. **The subsurface soil cleanup goals apply only to the large WMA 1 and WMA 2 excavations, including the excavation sides to within one meter (3.3 feet) of the surface.**

## WVDP PHASE 1 DECOMMISSIONING PLAN

The Process Building is an unusually complex structure, much of which is built of heavily-reinforced concrete. Some cells and the spent fuel handling and storage areas extend far below the ground as explained in Section 3. Despite extensive decontamination efforts over a lengthy period, significant amounts of residual radioactivity and high radiation levels will remain in some parts of the structure at the beginning of the Phase 1 decommissioning work as indicated in Tables 4-7 and 4-8 of Section 4. Equipment containing significant amounts of radioactive contamination will also remain in some areas, such as the Liquid Waste Cell.

The process to be followed in demolition of the Process Building is outlined in Sections 7.3.3 and 7.3.8 below.

Remediation of the source area of the north plateau groundwater plume is being carefully planned. The process to be followed is outlined in Section 7.3.8. Conceptual engineering work performed in support of the Decommissioning EIS has been considered in design of the excavation. The excavation design makes use of an unusually thick (13 feet) vertical hydraulic barrier on the downgradient side to facilitate removal of as much contaminated soil as practical in that area. DOE has considered deep soil remediation experience at other DOE and commercial sites in developing plans to deal with this unusual remediation issue.

### Mitigative Measures

Actions will be taken as necessary to eliminate or reduce potential impacts to human health and the environment during the **Phase 1** decommissioning work and to prevent **contamination of non-impacted areas of the project premises and** recontamination of remediated areas.

The large excavations for WMA 1 and WMA 2 will be planned to minimize the impacts associated with handling of removed contaminated soil. **Methods such as the following will be used to mitigate potential impacts from excavated contaminated soil:**

- **Arranging excavated soil in the laydown areas to facilitate radiological surveys and sampling of the soil for waste characterization purposes,**
- **Protecting laydown areas with a suitable covering material,**
- **Using water spray to minimize airborne radioactivity from piles of dry excavated contaminated soil;**
- **Placing suitable covering material over excavated soil to prevent the spread of contamination by precipitation;**
- **Establishing earthen berms equipped with runoff collection capability around the laydown areas to control surface water runoff; and**
- **Making provisions for sampling, removal, appropriate treatment, and disposal of water collected inside the berms, such as releasing it through a permitted outfall.**

**Such measures will also be used as practical in managing contaminated soil excavated during infrastructure removal, such as during the removal of foundations and floor slabs.**

Fixatives and water spray will be used as necessary to minimize airborne radioactivity during demolition of contaminated structures and equipment. Suitable covering material will

be placed over radioactive waste stored outdoors to help prevent the spread of contamination.

Confinement structures also will be used or other radiological control measures taken to minimize the release of airborne radioactivity associated with removal of soil containing significant concentrations of radioactivity. Appropriate dust suppression measures will be taken also during demolition of noncontaminated concrete and steel and during transportation of waste generated in such work.

Mitigative measures will include as low as reasonably achievable (ALARA) considerations, such as removal of contaminated soil to concentrations below the cleanup goals in cases where this will be practical.

Special emphasis will be placed on measures to ensure that areas remediated during Phase 1 are not re-contaminated during subsequent Phase 1 decommissioning activities and that those areas not impacted by radioactivity are not inadvertently contaminated. Such measures will include use of suitable barriers, such as temporary fences, and warning signs.

Mitigative measures will also be taken to minimize impacts to areas where slurry will be mixed in connection with installing the hydraulic barriers as described in Section 7.3.8. Measures will also be taken to avoid damage to the hydraulic barriers after they are installed from subsequent Phase 1 decommissioning activities. These measures will include protecting the barriers from impacts associated with the movement of heavy equipment, such as by the use of temporary load-distributing or bridging spans at the ground surface in the locations where such equipment will cross the barriers.

Details will be provided in the Decommissioning Work Plan(s) or in a separate Mitigative Measures Plan.

### **Radiological Controls**

Radiological controls and personnel monitoring during decommissioning activities will be in accordance with the DOE radiological control procedures identified in Section 1.7.

### **Worker Safety**

DOE will follow its internal requirements discussed in Section 1.7 and all other applicable requirements to ensure worker safety during the decommissioning work. These requirements will be detailed in a project Health and Safety Plan.

### **Waste Management**

All waste generated during Phase 1 of the decommissioning will be disposed of offsite. The Waste Management Plan will implement DOE procedures identified in Section 1.9 and provide requirements and guidance for management of all types of waste.

In accordance with the Waste Management Plan, radioactive waste generated during proposed decommissioning activities will be characterized and disposed of offsite at appropriate government-owned or commercial disposal facilities. Hazardous and toxic waste will be managed and disposed of offsite in accordance with applicable requirements. Non-radioactive equipment and demolition debris will be disposed of offsite at a construction and demolition debris landfill.



## WVDP PHASE 1 DECOMMISSIONING PLAN

DOE policies on waste minimization, pollution prevention, and recycling will be followed as specified in DOE Manual 435.1-1 *Radioactive Waste Management Manual*. Recycling of surplus equipment and metals such as radioactively contaminated lead in accordance with appropriate guidance will be considered.

Soil laydown areas will be located following guidance in the Waste Management Plan. Mitigative measures will be implemented for these areas as discussed previously. After the soil and ground covering material have been removed from these areas, they will be considered to have been impacted by radioactivity, even if there were no known spills. Phase 1 final status surveys will be performed in these areas as specified in Section 9 and the Phase 1 Final Status Survey Plan.<sup>2</sup>

### **Backfill Soil**

Soil used as backfill in deep and shallow excavations associated with Phase 1 decommissioning activities will be obtained from outside the Center from an area that has not been impacted by site radioactivity. The properties of soil to be used as backfill in the deep excavations in WMA 1 and WMA 2 – especially the texture, hydraulic conductivity, and distribution coefficients – will be similar to those of the sand and gravel layer on the project premises as described in Section 3.

No soil removed during the excavation work will be used in filling an excavation, even if that soil were determined to be uncontaminated.

### **Quality Assurance**

The quality assurance requirements of Section 8 will be adhered to during engineering analysis and design, compilation of engineering data, characterization, and the Phase 1 final status surveys. Applicable DOE quality assurance requirements will be implemented in other decommissioning activities.

### **Conceptual and Detailed Designs**

This plan describes the processes to be utilized during remediation activities in general terms and designs for engineered barriers and supporting facilities in a conceptual fashion. Detailed procedures for the remediation processes will later be developed consistent with the DOE policy stated above. Likewise, more detailed designs will later be developed for engineered barriers and other engineered features of the decommissioning.

### **Characterization**

As indicated in Section 4, the WVDP facilities and areas had not been completely characterized for radioactivity as of 2009. Additional characterization will be performed as necessary in accordance with the Characterization Sample and Analysis Plan, as explained in Section 9.

---

<sup>2</sup> Contamination found in excess of surface soil cleanup goals will be remediated as specified in Section 9.6. DOE may approve an exception to this requirement if the laydown area is located in a part of the project premises known to have subsurface radioactivity, or if surface soil contamination in excess of the cleanup goals was known to be present prior to establishing the laydown area.



## WVDP PHASE 1 DECOMMISSIONING PLAN

The Characterization Sample and Analysis Plan will provide for characterizing soil and sediment. This characterization program will include the banks and streambeds of the portions of Erdman Brook and Franks Creek located on the project premises<sup>3</sup>.

Characterization of subsurface soil in the area of the large WMA 1 and WMA 2 excavations will include collecting samples in the top portion of the Lavery till, as well as samples in the sand and gravel layer above the till. Samples of subsurface soil will also be collected along the upgradient and cross-gradient sides of the excavation footprint in WMA 1 and on the sides of the WMA 2 excavation footprint. Analytical data from these samples (1) will help determine the best location for the excavation boundaries, (2) may be useful in refining the conceptual model used in developing subsurface soil DCGLs as described in Section 5, (3) will help plan excavated soil management, and (4) will support planning Phase 1 final status surveys to be performed on the sides of the excavations.

Characterization measurements will include those necessary for waste management purposes. The Waste Management Plan will address characterizing excavated soil for waste management purposes, including surface and subsurface soil that is not likely to have been contaminated by radioactivity.

Note that the specific decommissioning activities described below are based on assumptions about conditions that will be encountered during the course of the work. If characterization were to disclose unexpected conditions, the decommissioning activities will be changed as necessary to ensure that conditions at the conclusion of the Phase 1 decommissioning activities meet the DCGLs (i.e., the cleanup goals). This plan will be revised as appropriate under these circumstances with NRC involvement as described in Section 1.13.

### DCGLs and Cleanup Goals

DCGLs for surface soil, subsurface soil, and stream sediment referred to in this section are the cleanup goals specified in Table 5-14 in Section 5. The DCGLs and cleanup goals for Sr-90 and Cs-137 are based on a 30-year decay period, as discussed in Section 5.2.

### ALARA Analyses

The results of the preliminary ALARA analysis are described in Section 6. As specified in Section 6, additional ALARA analyses will be performed during the WMA 1 and WMA 2 excavations using in-process survey data. These analyses will determine whether remediation to residual radioactivity concentrations below the cleanup goals will be cost-effective. If this is determined to be the case, then additional subsurface soil will be removed as indicated by the results of the analyses.

### Establishing Areas Where Surface Soil Meets Cleanup Goals

DOE may elect to establish during Phase 1 of the decommissioning that certain areas of the project premises meet the surface soil cleanup goals, depending on factors such as

---

<sup>3</sup> It is not intended that the characterization extend outside of the project premises, even in cases where environmental media contamination has been previously identified outside of the project premises, i.e., in the cesium prong area to the northwest of the project premises and in stream sediment in Franks Creek downstream of the project premises.

characterization results and available project funding. Any such areas would be selected after evaluation of data from the characterization program; only areas with no subsurface contamination below one meter from the surface would be selected.

Surface soil in these selected areas would be remediated as necessary to achieve the surface soil cleanup goals although no remediation may be necessary in some areas. Phase 1 final status surveys would be performed in the selected areas, along with any confirmatory surveys desired by NRC. Details are provided in Section 7.11.

### **In-Process Radiological Surveys**

In-process surveys will be performed in connection with the decommissioning activities for radiation protection and waste management purposes in accordance with the requirements of Section 9. These surveys will include sampling of excavated soil from both the deep and shallow excavations to support waste management.

### **Radiological Status Surveys of Shallow Excavations**

Radiological status surveys will be performed in the shallow excavations resulting from removal of infrastructure such as concrete floor slabs and foundations and gravel pads. The Characterization Sample and Analysis Plan will provide the requirements for these surveys.

### **Final Status Surveys and Confirmatory Surveys**

Phase 1 final status surveys will be accomplished in accordance with the Phase 1 Final Status Survey Plan, which will also address confirmatory surveys to be performed by NRC or its contractor, as explained in Section 9 of this plan. When Phase 1 final status surveys are specified below, inherent in the survey process will be any additional remediation necessary to achieve the cleanup criteria and resurveys of areas remediated to ensure that the criteria were achieved.<sup>4</sup>

The Phase 1 final status surveys focus primarily on areas to be made inaccessible by proposed decommissioning activities. Phase 1 final status surveys will be performed and confirmatory surveys coordinated with NRC or its contractor before these areas are made inaccessible. An example of such an area would be the lagoon excavation in WMA 2, which will be filled with radiologically uncontaminated earth imported from offsite only after the Phase 1 final status surveys and confirmatory surveys have been accomplished and the resulting data reviewed and accepted.

Phase 1 final status surveys will also be performed in excavated soil laydown areas and may also be performed in selected areas with no subsurface contamination that can meet surface soil cleanup criteria for unrestricted release.

For an excavated soil laydown area, Phase 1 final status surveys will be performed after the excavated soil and the ground covering is removed. The purpose of such surveys is generally to verify that the surface soil meets the cleanup goals. However, if the laydown

---

<sup>4</sup> Section 9 uses the term *Phase 1 final status surveys* to describe these surveys of excavations, which will follow the final status survey protocols of the *Multi-Agency Radiation Survey and Site Investigation Manual (MARSSIM)* (NRC 2000).

## WVDP PHASE 1 DECOMMISSIONING PLAN

area is known to have subsurface soil contamination, then the purpose of the surveys is to document the surface soil radiological conditions because such an area could not meet criteria for unrestricted release based only on surface soil contamination criteria.

Impacted areas that could be released for unrestricted use based on meeting surface soil cleanup goals may be identified during the characterization program, as noted previously. DOE will notify NRC at least 60 days before performing Phase 1 final status surveys to demonstrate that a particular area meets criteria for unrestricted release.

Surveys of excavations to remove infrastructure will be performed in accordance with the Characterization Sample and Analysis Plan, not the Phase 1 Final Status Survey Plan. An example of such a survey would be the shallow excavation made to remove the LLW2 Building floor slab and foundation.

### Monitoring, Maintenance, and Security

DOE will be responsible for monitoring and maintenance of the project premises and for institutional controls until completion of Phase 2 of the WVDP decommissioning, which is assumed to occur after 2041. Details are provided in Appendix D.

### 7.3 WMA 1 Decommissioning Activities

This section describes the decommissioning activities in WMA 1, the Process Building and Vitrification Facility area, to be accomplished in Phase 1. Figure 7-1 shows WMA 1.

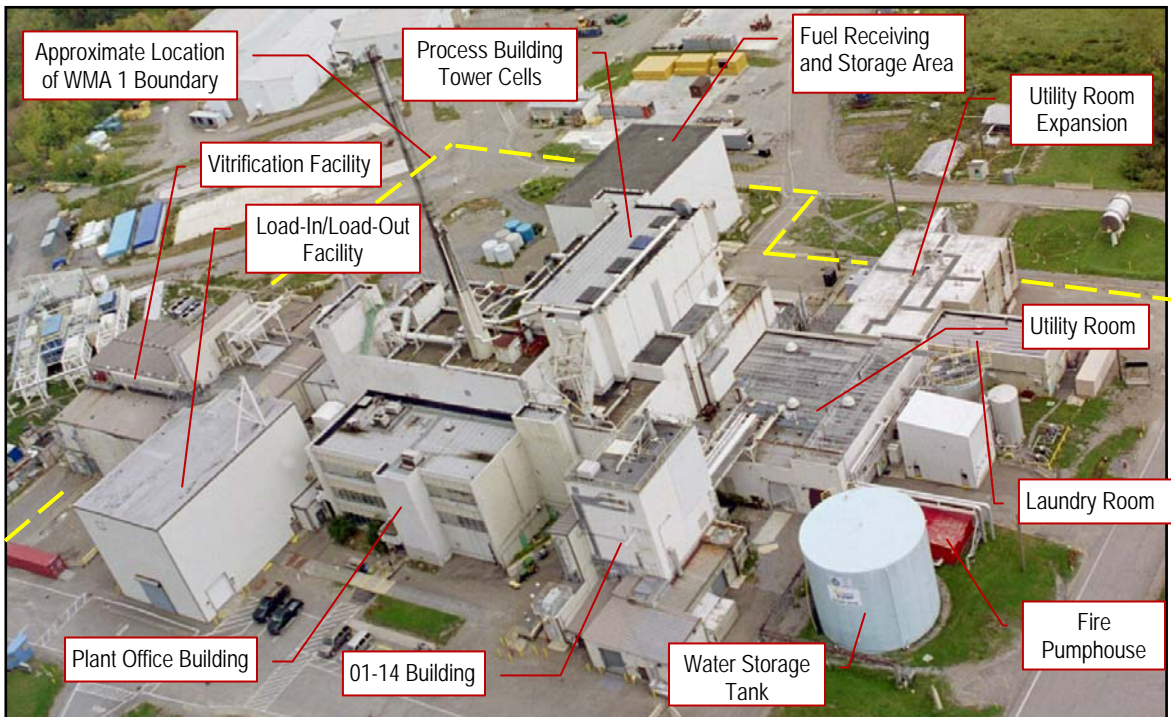

Figure 7-1. WMA 1 in 2007

### 7.3.1 Characterizing Soil and Streambed Sediment

Soil and sediment in WMA 1 will be characterized for residual radioactivity in accordance with the Characterization Sample and Analysis Plan described in Section 9. The results of this effort will be used in planning the excavation work described below.

### 7.3.2 Relocating the Vitrified HLW Canisters

The 275 vitrified HLW canisters will be relocated to the new Canister Interim Storage Facility to permit demolition of the Process Building.

#### General Approach

The new Canister Interim Storage Facility (if the approach is selected by DOE) will be set up on the south plateau. The Equipment Decontamination Room will be modified to support handling the vitrified HLW canisters and the Load-In Facility will be converted to a Load-Out Facility. The vitrified HLW canisters will then be moved from the HLW Interim Storage Facility (the former Chemical Process Cell) and loaded into shielded dry storage canisters. Each storage canister will be placed in a shielded onsite transport cask and moved by truck to the new Canister Interim Storage Facility. The storage canisters will be maintained there in protective storage until **a decision is made and implemented with regard to disposal of the HLW canisters.**

This approach is among several approaches described in conceptual engineering studies (WVNSCO and Scientech 2000, **WVES 2009b**) which **are** currently under evaluation by DOE. If this approach is selected by DOE, detailed designs based on the preliminary conceptual designs will be developed. These designs will take into account the size of the canisters (two feet in diameter by 10 feet long), their weight (approximately 5,000 pounds each), their high radiation levels (about 1,750 to 7,500 R/h when they were moved into the HLW Interim Storage Facility in the former Chemical Process Cell), and the amounts of radioactivity they contain (an average of approximately 37,000 curies each in 2005) (WVNSCO 2008)<sup>5</sup>. The DOE is expected to make a decision on the preferred approach in the near future. A shielded dry interim storage system similar to those used at nuclear power plants for spent nuclear fuel is assumed for purposes of this plan.

#### Procurement of Interim Storage System for the Vitrified HLW Canisters

The interim storage system will include 69 shielded canisters and shielded modules made of reinforced concrete in which to store these shielded canisters. Each shielded canister will be capable of (1) holding four vitrified HLW canisters, (2) being loaded in a horizontal position, (3) being transported onsite within a shielded transport cask by truck, and (4) being transported **offsite** within a shielded transport cask by rail. The shielded canisters will be used for both onsite storage within the reinforced concrete storage modules and transport within a shielded transport cask.

The onsite shielded transport cask will be capable of (1) holding a single shielded canister, (2) loading and discharging the shielded canister in a horizontal position, and (3)

---

<sup>5</sup> Table 2-10 in Section 2 shows the activity estimate for a typical HLW canister.

being positioned on the onsite transport trailer so the open end can be partially inserted into a shielded area during both loading and discharge.

NOTE

The conceptual designs described below for the modifications to the Equipment Decontamination Room and the Load-In Facility and for the new Canister Interim Storage Facility for the vitrified HLW canisters depend on the characteristics described above. If DOE were to use an interim storage system with different characteristics, this plan will be revised to reflect the appropriate changes.

**Modifications to the Equipment Decontamination Room**

These modifications will involve setting up the Equipment Decontamination Room to remotely handle the vitrified HLW canisters and prepare them for insertion into the shielded canisters. The vitrified HLW canisters will be moved into the Equipment Decontamination Room from the HLW Interim Storage Facility using the existing transfer cart, which holds four canisters in a vertical position, or in a similar conveyance. New equipment will be installed to remove the canisters from the transfer cart, lower them into a horizontal position, and move them into a shielded transfer cell constructed in the Load-In/Load-Out Facility.

**Conversion of the Load-In Facility**

The shielded transfer cell will be constructed at the east wall of the facility between the shield door to the Equipment Decontamination Room and the air lock. This cell will be designed for operators to remotely perform the following activities: (1) verify canister dimensions as necessary, (2) weigh the canisters, (3) measure gamma radiation levels and removable surface radioactivity, (4) decontaminate the outside surfaces of the canisters, (5) load them in the shielded storage canisters, (6) weld the storage canister lids in place, and (7) load the shielded storage canisters into the onsite transport cask.

The transfer cell will be constructed of material such as steel plate to provide necessary radiation shielding and facilitate dismantlement after use. One or more viewing windows and remote manipulators will be provided, along with ventilation utilizing high-efficiency particulate air (HEPA) filters.

To avoid the need to remove the shielded transport cask from the trailer, the transfer cell will be designed so that trailer can be backed up to it to position the cask to receive a loaded shielded storage canister. With this arrangement, the trailer will be supported by jacks for stability, the open end of the onsite transport cask will be positioned within the outer part of the transfer cell to provide necessary radiation shielding, and the loaded shielded canister will be inserted into the cask and the cask shield plug installed. Figure 7-2 shows the conceptual arrangement.

## WVDP PHASE 1 DECOMMISSIONING PLAN

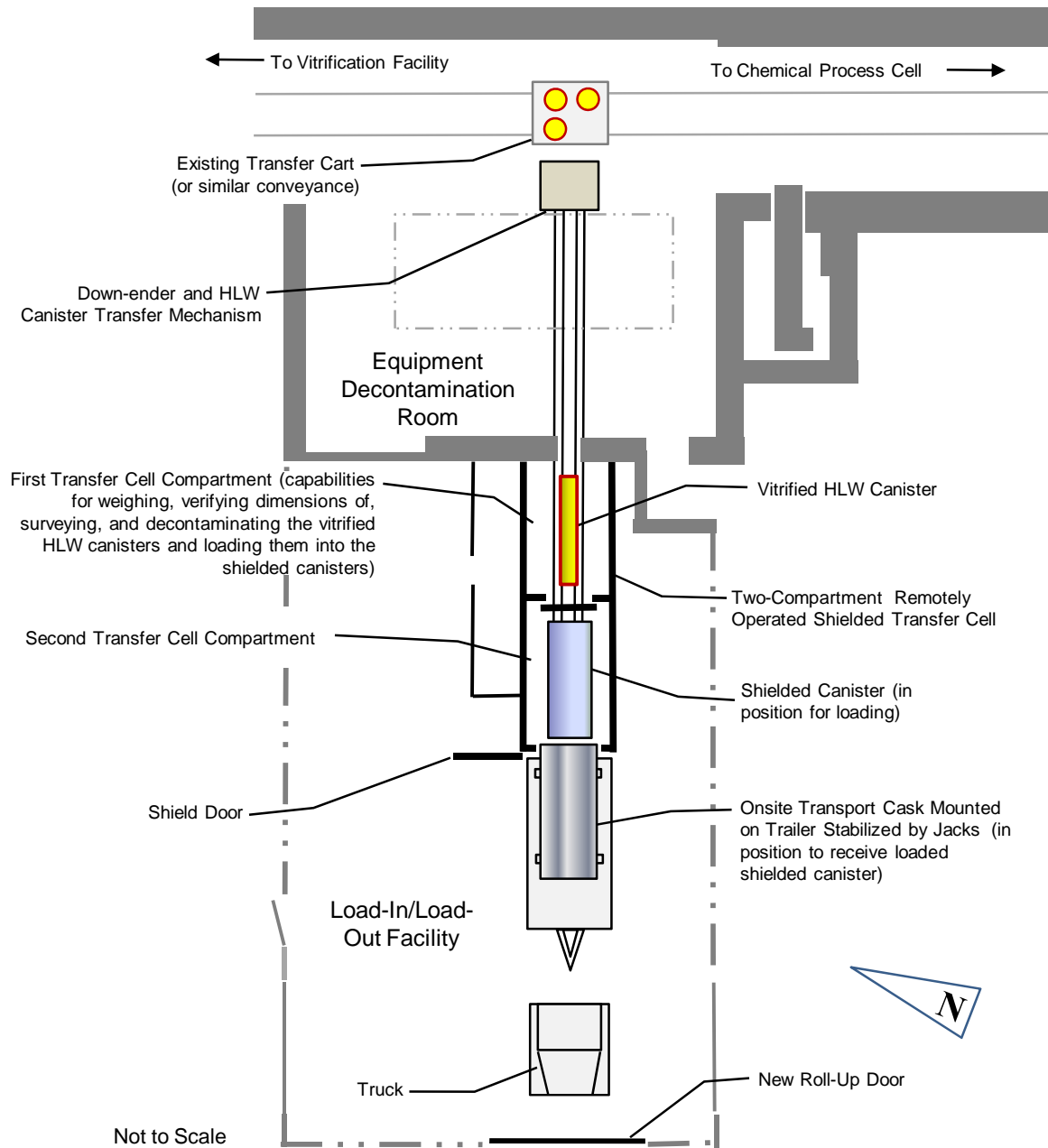

**Figure 7-2. Conceptual Arrangement for Transferring Vitrified HLW Canisters**

### **Construction of the New Canister Interim Storage Facility**

The new Canister Interim Storage Facility will be constructed on the south plateau near the rail spur.<sup>6</sup> The facility will consist of a reinforced concrete pad with reinforced concrete storage modules to provide radiation shielding and mechanical protection. The concrete pad will be sufficient in size and load capacity to accommodate reinforced concrete storage modules for the 69 loaded shielded canisters. **Soil in the area will be characterized for**

<sup>6</sup> A report of a detailed evaluation of HLW canister storage options issued in September 2009 recommended this location (WVES 2009b).



geotechnical parameters to support the detailed design of the facility. The soil will also be characterized for radioactivity, either in connection with the geotechnical investigation or as provided for in the Characterization Sample and Analysis Plan.

Figure 7-3 shows the conceptual design for a storage module, which is similar to the NUHOMS<sup>®</sup> standard horizontal storage module provided by AREVA (Transnuclear Incorporated) for dry storage of containerized spent nuclear fuel. (This design is provided as an example only and its inclusion here does not imply that DOE will necessarily select this interim storage system, which is among a variety of systems approved by NRC for general use that will be considered by DOE.)

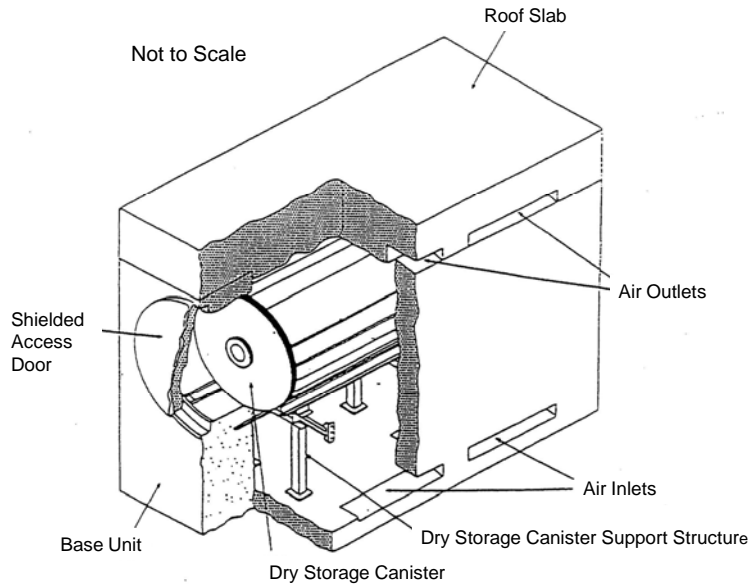

**Figure 7-3. Storage Module Conceptual Design** (from WVNSCO and Sciencetech 2000)

Appropriate fence(s), lighting, and remote monitoring equipment for security purposes will be provided. DOE will consider applicable NRC guidance in detailed design of the new Canister Interim Storage Facility, such as that found in NUREG-1536, *Standard Review Plan for Dry Cask Storage Systems* (NRC 1997). DOE will provide information on the detailed design of the facility to NRC and consult with NRC on preparation of the related **documented** safety analysis.

### **Moving the Vitrified HLW Canisters to the New Canister Interim Storage Facility**

A process such as the following will be used to transport the vitrified HLW canisters to the new Canister Interim Storage Facility:

- Readiness reviews will be performed to ensure that all preparations for the move have been satisfactorily completed;
- The first shielded canister will be placed inside the shielded transfer cell;
- The onsite transport cask to receive the first shielded canister will be moved into the Load-In/Load-Out Facility and positioned next to the transfer cell;
- The first group of four vitrified HLW canisters will be moved into the Equipment Decontamination Room on the transfer cart or similar conveyance;



## WVDP PHASE 1 DECOMMISSIONING PLAN

- The vitrified HLW canisters will be lifted from the cart one by one, lowered to a horizontal position, and moved into the transfer cell where appropriate measurements will be taken;
- After measurements and any necessary decontamination are completed, each of the four vitrified HLW canisters will be loaded into a shielded canister and the shielded canister will be loaded into the onsite transport cask; and
- The cask will be transported to the new Canister Interim Storage Facility where the shielded canister will be inserted into the designated reinforced concrete storage module and the module shielded access door installed.

This process will be repeated until all 275 vitrified HLW canisters have been relocated to the new Canister Interim Storage Facility.

### 7.3.3 Removing the Above-Grade Portion of the Process Building

As explained in Section 3, the Process Building is a complex structure comprised of various shielded cells, rooms, aisles, and supporting areas. It is approximately 270 feet long, 130 feet wide, and stands 79 feet above ground. Much of the structure is formed of heavily reinforced concrete. Figure 7-4 illustrates the Process Building and identifies key areas.

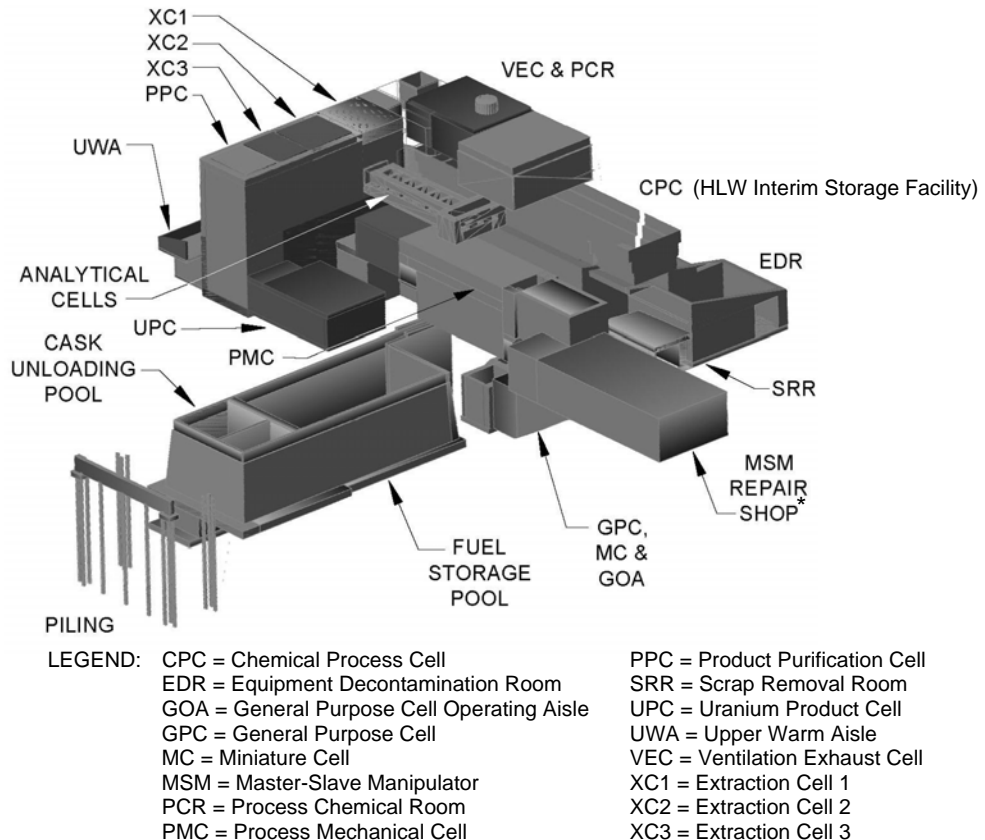

\*The MSM Repair Shop and the Contact Size-Reduction Facility now located in this area will be removed before the decommissioning begins.

**Figure 7-4. Process Building General Arrangement**

## WVDP PHASE 1 DECOMMISSIONING PLAN

Removal of the above-grade portion of the Process Building will be performed as specified below. The below-ground portion of the building will be removed as specified in Section 7.3.8. As indicated previously, this work will be performed in accordance with the Decommissioning Work Plan, which will provide more details on the activities described below.

### Removing Equipment

Equipment will be removed **in connection with** demolition of the building. Equipment to be removed from the areas that supported interim storage of the vitrified HLW canisters includes the canister storage racks and ventilation equipment in the HLW Interim Storage Facility, remote manipulators, the two cranes in the Chemical Crane Room, the vitrified HLW canister handling equipment in the Equipment Decontamination Room, and various pieces of ventilation equipment.

Other equipment remaining inside the Process Building after the interim end state is reached – such as the vessels in the Liquid Waste Cell, other vessels and equipment, the other cranes, and the master-slave manipulators – will also be removed. This equipment will be size reduced as necessary, characterized, packaged, and disposed of offsite. Size reduction will be accomplished either in the areas where the equipment is located or in another area set up for this purpose, such as the Vitrification Cell in the Vitrification Facility.

### Removing Hazardous and Toxic Materials

Hazardous and toxic materials in the building will be removed to the extent practical before demolition. These materials will include:

- Any remaining temporary lead shielding and all permanently-installed lead shielding from areas such as the wall outside of the Off-Gas Blower Room and the shield doors and door frames in the Radiological Counting Room;
- The lead-glass viewing windows, whose frames contain lead;
- Any remaining bulk hazardous materials;
- **Any electrical equipment known to contain mercury, such as switches, relays, and fluorescent lamps;**
- Any electrical equipment known to contain polychlorinated biphenyls (PCBs); and
- Any remaining piping insulation known to contain asbestos.

These materials will be size reduced as necessary, characterized, packaged, and disposed of at an appropriate offsite disposal facility. **Lead-based paint affixed to facility surfaces would not have to be removed from the demolition debris for the debris to be disposed of as radioactive waste at a disposal facility such as the EnergySolutions Clive, Utah facility or as non-radioactive waste at a construction and demolition debris landfill.**

### Completing Process Building Decontamination

Process Building areas known to have significant residual radioactivity will be evaluated and decontaminated as necessary to support unconfined demolition of the building, including the following areas used to support vitrified HLW canister storage:

## WVDP PHASE 1 DECOMMISSIONING PLAN

- HLW Interim Storage Facility
- Chemical Crane Room
- Equipment Decontamination Room
- Ventilation Exhaust Cell
- Head-End Ventilation Building

The process used will involve activities such as the following:

- Removing remaining equipment from these areas, size reducing it as necessary, characterizing it, packaging it, and disposing of it at appropriate offsite disposal facilities;
- Performing radiological characterization surveys as specified in Section 9 to assess the extent of contamination on facility surfaces; and
- On the basis of **characterization results**, verify that the Process Building can be demolished without **exceeding NESHAP** limits (40 CFR 61), making use of the CAP88-PC code (EPA 2007) and considering other sources of airborne radioactivity emissions during the calendar year in which the demolition will be accomplished.

### Removing the Building to Grade Level

The Process Building will be demolished to grade level using conventional demolition methods such as those described in Section 7.12. Fixatives will be applied to building surfaces with significant radioactive contamination before this is accomplished to help avoid the need for radiological containment. **A fog spray will be used as appropriate during the demolition process.** The resulting debris will be sized reduced as necessary, packaged for disposal or managed as bulk waste, and disposed of offsite at an appropriate waste disposal facility.

Demolition of the building to grade level will be coordinated with demolition of other WMA 1 facilities and installation of the vertical hydraulic barrier wall for the WMA 1 excavation described in Section 7.3.8.

### 7.3.4 Removing the Above-Grade Portion of the Vitrification Facility

As explained in Section 3, this structural steel frame and sheet metal building houses the reinforced concrete Vitrification Cell, operating aisles, a control room, and other support areas. It is approximately 91 feet wide and 150 feet long. The peak of the roof stands approximately 50 feet high with the crane house extending another 26 feet above the roof. Figures 3-11 through 3-21 show the outside of the building and representative interior areas.

Removal of the above-grade portion of the Vitrification Facility will be performed as specified below. The below-grade portion of the building will be removed as specified in Section 7.3.8.

### Preparing for Facility Removal

Preparations to remove the Vitrification Facility to grade will be similar to those for the Process Building. Installed equipment will be removed as necessary, along with the nine lead glass viewing windows in the Vitrification Cell and any remaining hazardous and toxic materials. Residual radioactivity levels inside the Vitrification Cell will be evaluated to

ensure compliance with NESHAP emission limits during demolition. Fixatives will be applied to surfaces with significant radioactive contamination levels.

### **Removal of the Facility to Grade Level**

After such preparations are completed, the Vitrification Facility will be removed to grade level using conventional demolition methods such as those described in Section 7.12. The thick reinforced concrete walls and roof structures will be segmented as necessary using a technique such as diamond wire cutting.

The resulting debris will be sized reduced as necessary, packaged for disposal or managed as bulk waste, and disposed of offsite at an appropriate waste disposal facility. The demolition work will be coordinated with demolition of the Process Building and the other WMA 1 facilities and with removal of piping in the HLW transfer trench in WMA 3, which connects to the north side of the building.

### **7.3.5 Removing the 01-14 Building and the Vitrification Off-Gas Line**

As indicated in Section 3, the four-story 01-14 Building stands at the southwest corner of the Process Building. Figure 3-11 shows the building. The 10-inch vitrification off-gas line runs from the Vitrification Facility to the 01-14 Building in a 340 feet long subgrade concrete trench.

An approach such as the following will be used to remove this building to its floor slab and foundation:

- Performing characterization surveys;
- Removing any remaining equipment from the building, along with any hazardous or toxic materials and the lead-glass viewing window (the frame contains lead);
- Decontaminating the building structure and applying fixatives if necessary to allow demolition without the use of containment; and
- Demolishing the structure to its floor slab and foundation, as well as the cement silo and the entrance enclosure; and
- Characterizing the resulting debris, packaging it for disposal or managing it as bulk waste, and disposing of it at an offsite disposal facility.

The floor slab and foundation will remain in place temporarily and will be removed in connection with the excavation of the underground portions of the Process Building and Vitrification Facility and the source area of the north plateau groundwater plume.

The off-gas line will be cut into segments, removed from the concrete trench, characterized, packaged for disposal, and disposed of at an offsite disposal facility. The trench itself will remain in place temporarily and will be removed in conjunction with removal of the WMA 1 subgrade structures and the plume source area.

### **7.3.6 Removing the Load-In/Load-Out Facility**

As explained in Section 3, this 60 feet by 70 feet by 54 feet high steel building has a concrete floor. The process for removal of this building will be similar to the process used for the 01-14 Building and will include major steps such as the following:

- Performing characterization surveys;

## WVDP PHASE 1 DECOMMISSIONING PLAN

- Removing equipment such as the vitrified HLW canister handling system, lead glass windows in the transfer cell, and the crane;
- Decontaminating the facility and applying fixatives to surfaces with significant radioactive contamination to facilitate demolition without containment;
- Demolishing the structure to its floor slab and foundation; and
- Characterizing the resulting debris, packaging it for disposal or managing it as bulk waste, and disposing of it at an offsite disposal facility.

The floor slab and foundation will remain in place temporarily and will be removed in conjunction with removal of the WMA 1 subgrade structures and the plume source area.

### 7.3.7 Removing Other WMA 1 Structures

The remaining WMA 1 structures will be removed to their concrete floor slabs and foundations, which will be removed during excavation of the subgrade structures and the plume source area. (Note that some WMA 1 facilities and parts of others lie outside of footprint of the large excavation; these are discussed below.)

#### Utility Room and Utility Room Expansion

The Utility Room and the Utility Room Expansion are concrete block structures containing site utilities as explained in Section 3. The decommissioning process for these facilities will include steps such as the following:

- Performing characterization surveys,
- Removing equipment from the building, along with any hazardous or toxic materials;
- Demolishing the building to its floor slab and foundation;
- Characterizing the resulting debris, managing it as bulk waste, and disposing of it at an offsite disposal facility.

#### Plant Office Building

The three-story concrete block Plant Office Building is shown in Figures 3-11 and 7-1. Decommissioning this structure will entail a process such as the following:

- Performing characterization surveys;
- Removing equipment from the building, along with any hazardous or toxic materials;
- Demolishing the building to its floor slab and foundation; and
- Characterizing the resulting debris, managing it as bulk waste, and disposing of it at an offsite disposal facility.

#### Fire Pump House

As of late 2009, this 20 feet by 24 feet by 10 feet high steel building was not known to have been impacted by radioactivity. Decommissioning this structure will entail a process such as the following:

- Performing characterization surveys to confirm that the building is not impacted by radioactivity;

## WVDP PHASE 1 DECOMMISSIONING PLAN

- Removing equipment only to the extent necessary to support building demolition; and
- Demolishing the building to its floor slab and foundation, disposing of the debris in an offsite landfill.

### **Water Storage Tank**

This 475,800-gallon tank was not known to have been impacted by radioactivity as of late 2009. Decommissioning will entail emptying the tank, draining the water to the storm sewer system, and dismantling the tank.

### **Electrical Substation**

This 34.5 kilovolt/480 volt transformer was not known to have been impacted by radioactivity as of late 2009. Decommissioning will entail de-energizing it and removing it, with the equipment containing PCBs managed in accordance with applicable State and U.S. Environmental Protection Agency requirements.

### **Removal of Floor Slabs and Foundations Outside of the Large Excavation**

The floor slabs and foundations of those WMA 1 structures that lie outside of the footprint of the large excavation will be removed. These structures include portions of the Utility Room and Utility Room Expansion, the Fire Pumphouse, and the Water Storage Tank. This work, which will be coordinated with the activities in Sections 7.3.8 and 7.3.9, will entail using a process such as the following:

- Removing the concrete and the underlying soil to approximately two feet below grade;
- Disposing of the demolition debris and soil at appropriate offsite facilities;
- Performing radiological status surveys in the shallow excavations;
- Evaluating the resulting data and performing Phase 1 final status surveys as applicable in accordance with Section 7.11;
- Arranging for any confirmatory surveys to be performed; and
- After all of the surveys are completed and any issues resolved, backfilling the shallow excavations with clean earthen backfill.

### **7.3.8 Removing the Underground Structures and Equipment and the Plume Source Area**

Figure 7-5 shows the layout of the underground portions of the Process Building. The floor of the melter pit in the Vitrification facility, which is not shown on this figure, also extends approximately 14 feet below grade.

To facilitate removal of the underground structures of the Process Building and Vitrification Facility, along with the source area of the north plateau groundwater plume, an area larger than the footprint of both buildings will be excavated. Figure 7-6 shows this area.

Figure 7-6 provides information on Sr-90 contamination in groundwater that represents the upgradient portion of the north plateau groundwater plume based on measurements made in the 1998 investigation (Hemann and Steiner 1999). This figure also shows the

## WVDP PHASE 1 DECOMMISSIONING PLAN

location of the **assumed** main source of the plume, identified near the bottom of the drawing as "7P-240 Release," and key underground lines in the area.

Figure 7-7 shows a cross section view of the excavation. This figure also shows key soil contamination data from Geoprobe® samples collected in the 1998 investigation (Hemann and Steiner 1999).

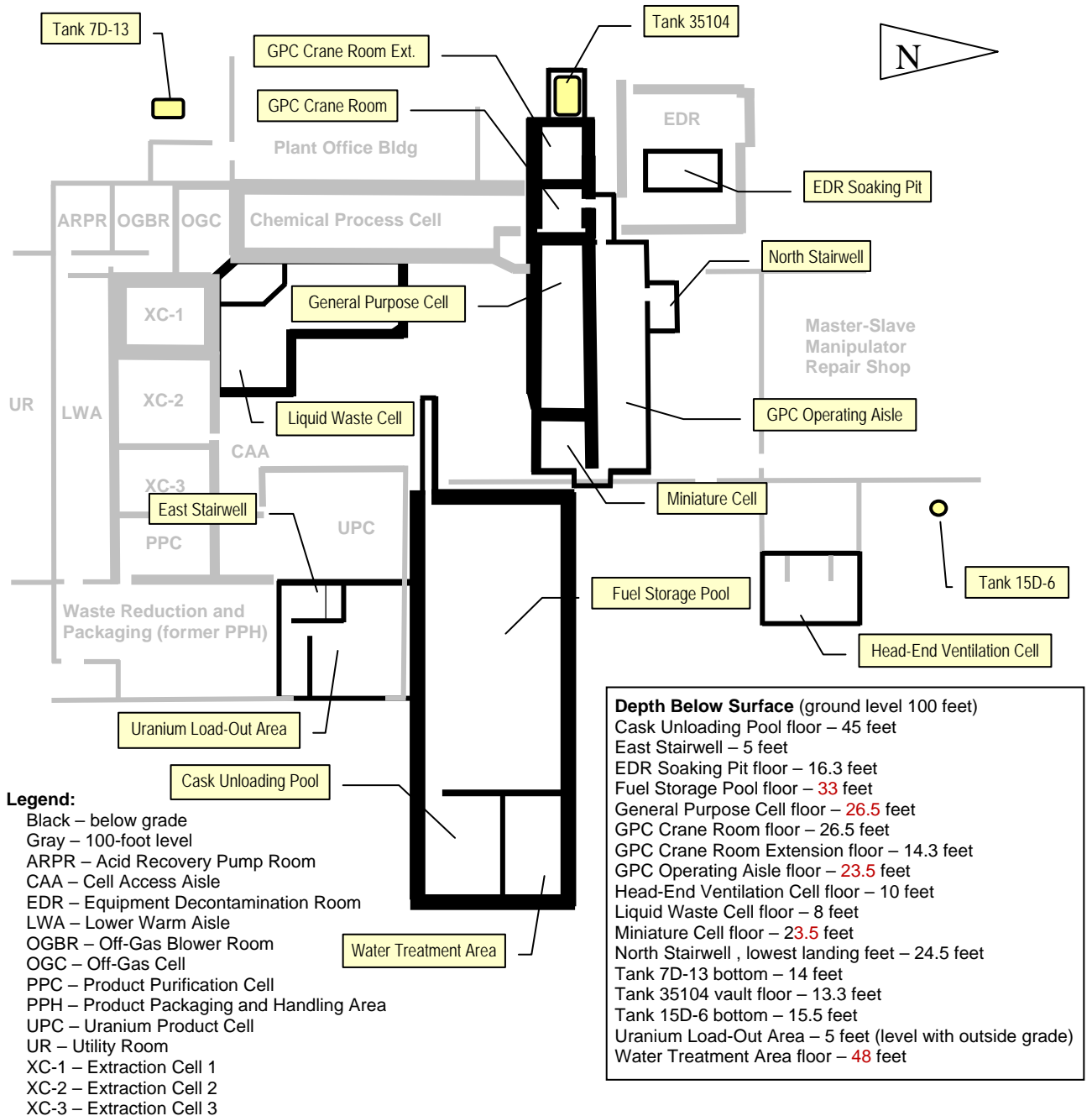

**Figure 7-5. Layout of Process Building Underground Structures**



WVDP PHASE 1 DECOMMISSIONING PLAN

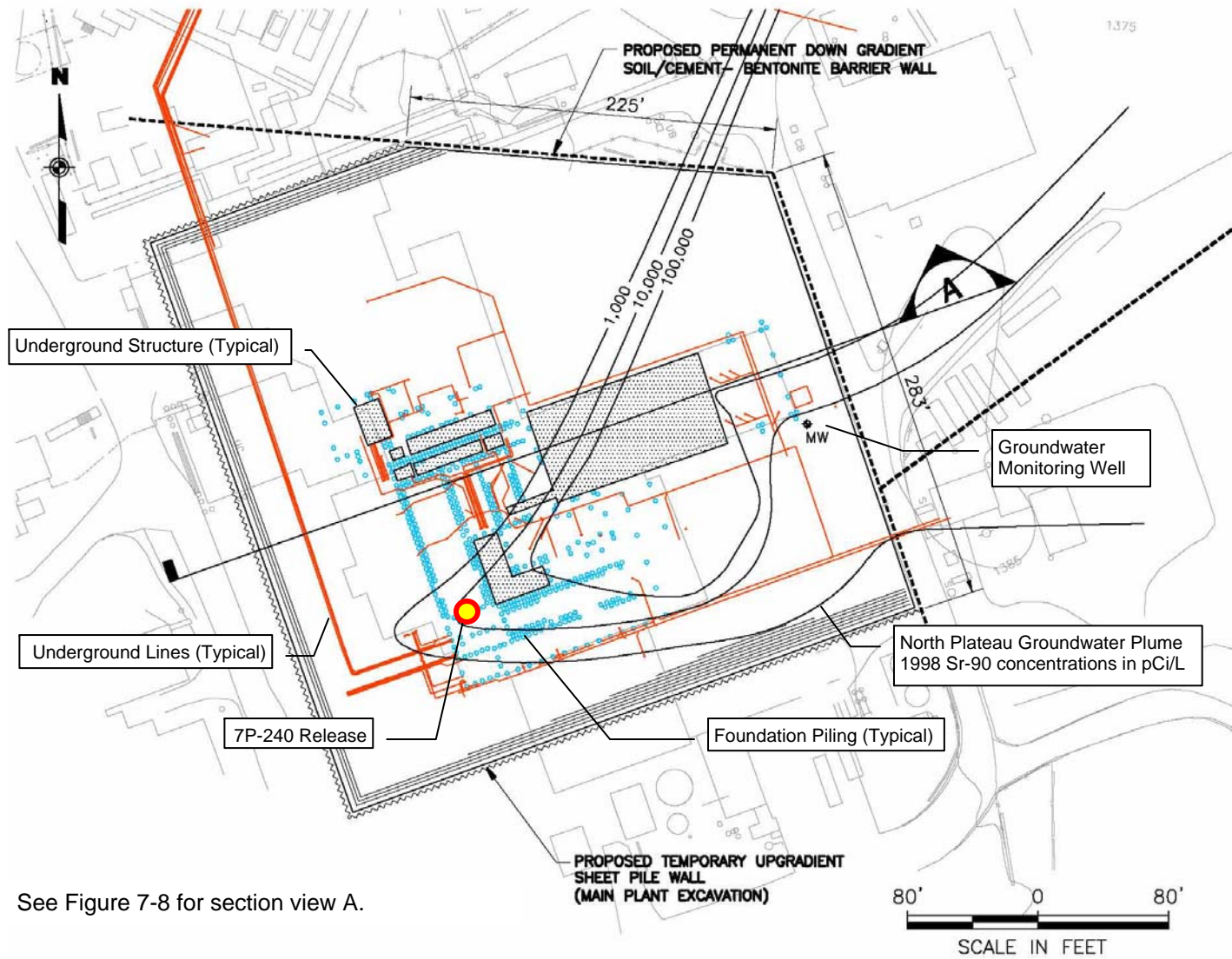

See Figure 7-8 for section view A.

Figure 7-6. Conceptual Layout of WMA 1 Excavation

# WVDP PHASE 1 DECOMMISSIONING PLAN

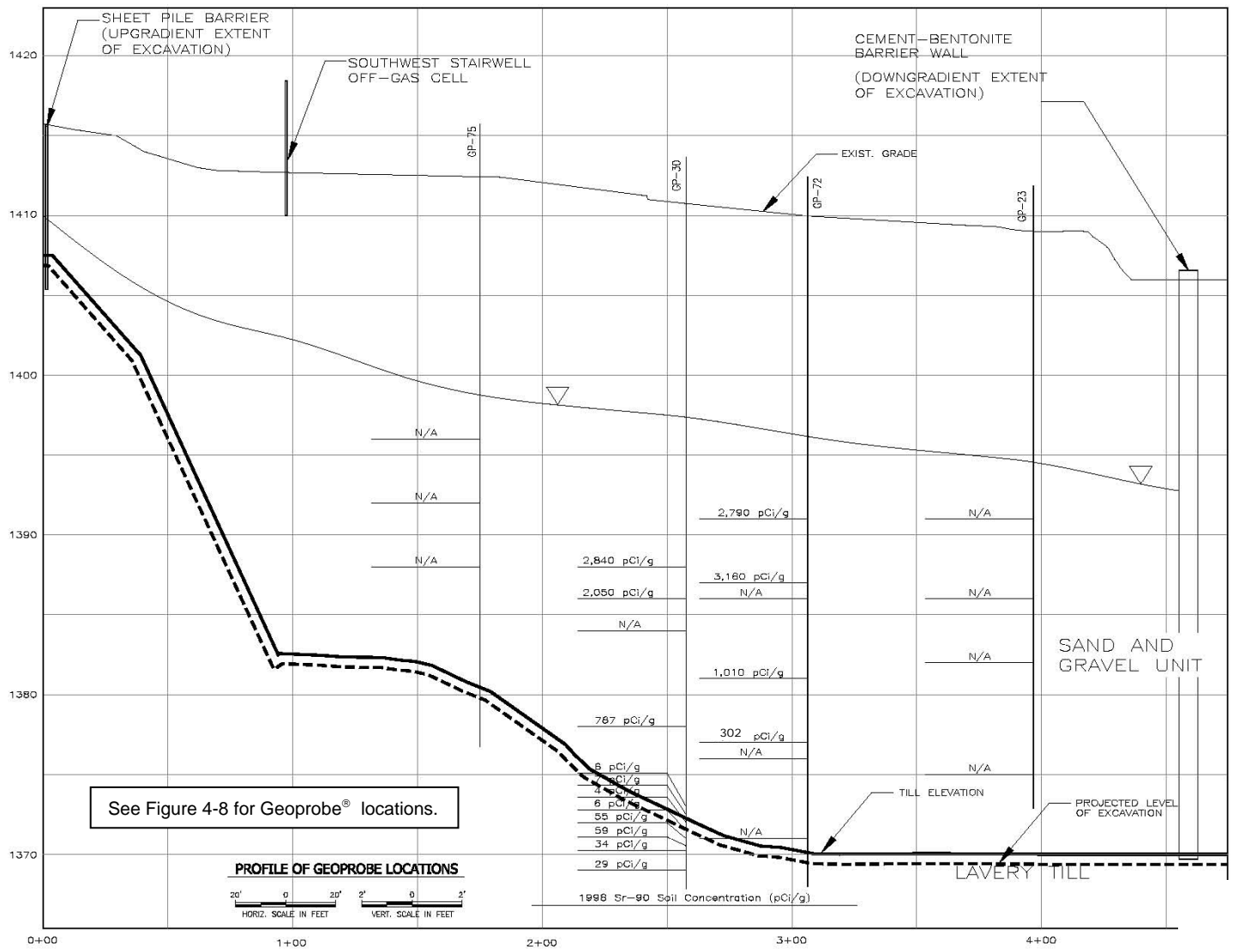

Figure 7-7. Conceptual WMA 1 Excavation Contour, With Selected Subsurface Soil Data

# WVDP PHASE 1 DECOMMISSIONING PLAN

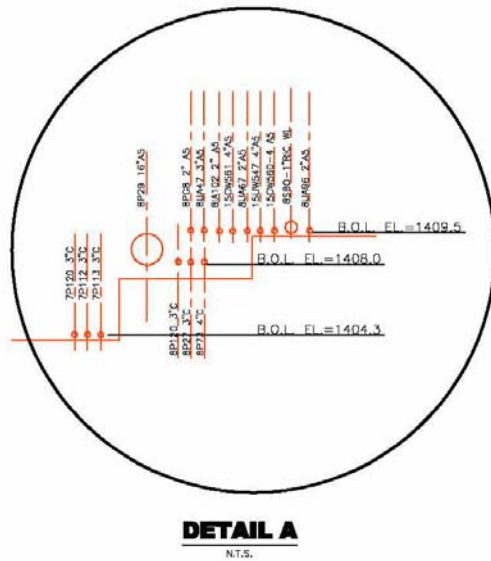
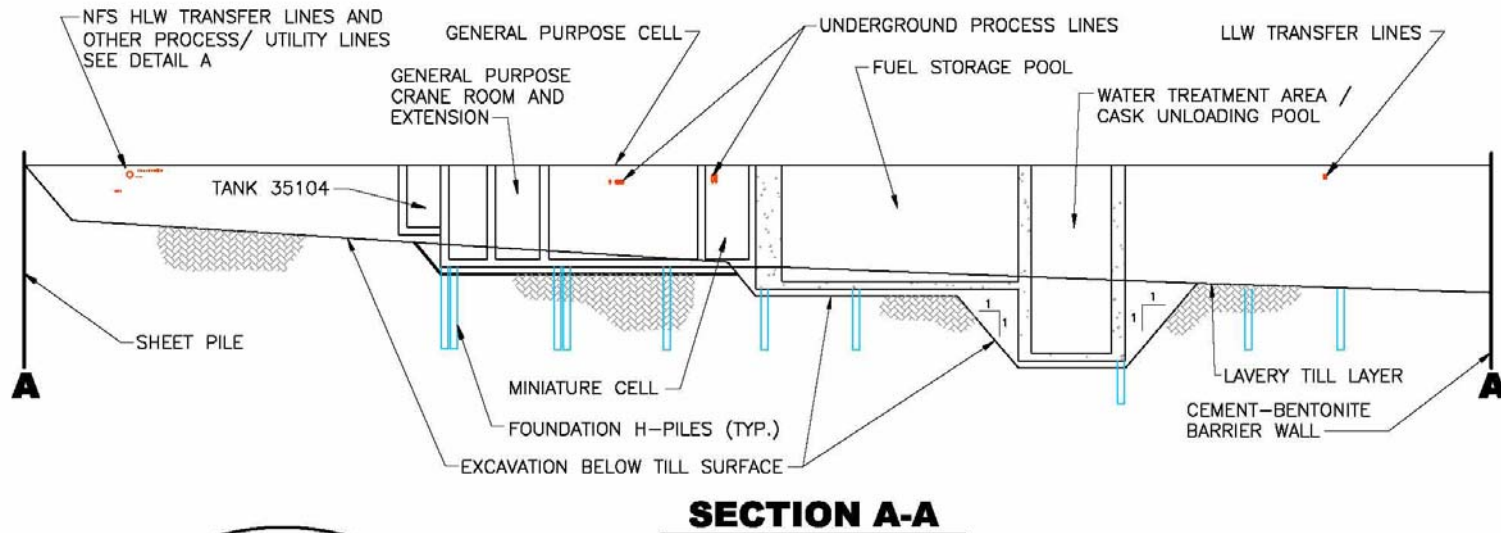

Figure 7-8. Excavation Cross Section

### Excavation Conceptual Design

The horizontal limits of the excavation will be based primarily on physical considerations, although consideration will also be given to analytical data on subsurface soil contamination at the planned excavation boundary acquired during the characterization program. As can be seen in Figure 7-6, the western edge of the excavation will lie near the road in front of the Plant Office Building. The northern edge of the excavation will follow the walkway between the Vitrification Facility and the Waste Tank Farm. The eastern edge will follow the road between the Process Building area and the interceptors. The southern edge will correspond with a line running immediately south of the 01-14 Building, the Utility Room, and the Utility Room Expansion. The footprint of the excavation will comprise approximately three acres.

The depth of the excavation will vary depending on the subsurface structures. Figure 7-8 shows a representative cross section (which is identified on Figure 7-6).

### Hydraulic Barrier Wall Installation

To control groundwater, a vertical hydraulic barrier will be installed around the area to be excavated as shown in Figure 7-6 and Figure 7-7. The upgradient portion will be built of sheet pile. The downgradient portion will consist of a soil-cement-bentonite slurry wall. Both will extend at least two feet into the Lavery till and the slurry wall will remain in place after the excavation is backfilled.

Before the hydraulic barrier wall is installed, underground lines within its footprint that carried radioactive liquid will be located. Sections of these lines in the area where the barrier walls will be constructed will be removed in a controlled manner to avoid unnecessary release of contamination. During this process, characterization measurements will be taken in the end of each line that will remain in place outside of the excavation and the line capped.

The total length of the slurry wall will be approximately 750 feet, with approximately 525 feet of this length directly adjacent to the WMA 1 area to be excavated. The 525-foot portion of the slurry wall adjacent to the area to be excavated will be sufficiently wide to provide the stability necessary to permit excavation up to the base of the wall, with the remainder a more typical two foot width. The extra width of the main portion of the slurry wall and the inclusion of cement in the mixture will provide the stability necessary to accommodate the nearby excavation.<sup>7</sup>

The sheet pile section of the hydraulic barrier wall will be installed using a conventional pile driver. Construction of the soil-cement-bentonite slurry wall will involve activities such as the following:

- Making preparations to handle the soil to be excavated, with characterization data, including data collected during the excavation process, used to determine the portion of the soil that is radioactively contaminated;
- Using a hydraulic excavator to dig the trench for installation of the slurry wall;
- Preparing the slurry and backfill mixtures in earthen containment berms that will be constructed near the slurry wall;

---

<sup>7</sup> Consideration of industry experience in use of slurry walls at the boundaries of deep excavations indicates that the barrier planned for the WMA 1 excavation will perform as planned in controlling groundwater intrusion and supporting the excavation design. The extra thickness will accommodate some excavation into the upper portion of the barrier wall with sufficient thickness remaining to ensure satisfactory performance.

---

## WVDP PHASE 1 DECOMMISSIONING PLAN

- Keeping the trench filled with slurry during the excavation process to help support the trench walls during the excavation;
- Backfilling the trench with a mixture of clean soil, cement, and bentonite to displace the slurry, which will then be used to continue the trench excavation;
- Collecting the radioactively contaminated removed soil in lift liners, adding absorbent to the saturated soil, and transporting it offsite for disposal **at an appropriate offsite disposal facility**; and
- Disposing of the uncontaminated soil at an appropriate offsite disposal facility.

The resulting slurry wall will have a maximum in-place saturated hydraulic conductivity of 6.0E-06 cm/s. It will extend to within about three feet of grade and be topped with uncontaminated soil.

### **Preparations for Removal of Contaminated Soil and Groundwater**

Removal of contaminated soil and groundwater is addressed first because of the issues in dealing with highly contaminated soil expected beneath the Process Building. However, removal of the underground structures and equipment will be coordinated with soil removal since the north plateau plume source area lies beneath the Process Building. Detailed planning for the excavation will take into account available information on radioactivity in the soil and groundwater as summarized in Section 4.2 and the results of the soil characterization program. The depth of the water table in the area – typically about 10 feet below the surface – will also be taken into account.

Preparations, in addition to installation of the hydraulic barrier wall, will include installation of extraction wells to dewater the excavation. The removed water will be sent to the Low-Level Waste Treatment Facility for treatment prior to discharge through a State Pollutant Discharge Elimination System (SPDES)-permitted outfall or, as an alternative, a portable wastewater treatment system using ion exchangers and filters provided for this purpose. Preparations will also include making provisions for appropriate radiological controls, such as design and erection of a pre-engineered confinement structure over the north plateau plume source area or over the entire excavation to provide for weather protection and airborne radioactivity control.

### **Removal of Contaminated Soil and Groundwater**

Before excavation begins, the hydraulic barrier wall will be installed, the sheet piles installed, the dewatering wells installed and placed in operation, and appropriate radiological controls established. The excavation process will be accomplished in two phases using conventional excavation equipment. **It is expected that approximately 75 percent of the soil to be excavated will be saturated. All soil removed from the excavation will be disposed of at appropriate offsite disposal facilities.**

The first phase will involve removal of soil in the vadose zone. **Characterization data will be used to determine that portion of the soil that is likely to be uncontaminated. These data, supplemented by in-process survey data collected as described in Section 9, will be used to segregate excavated soil that is unlikely to be contaminated from excavated soil that is determined to be contaminated. Guidance provided in the Waste Management Plan will be followed during these activities.**

Excavation of soil in the saturated zone will begin after the dewatering wells have removed groundwater in the confined area to the extent practical. The groundwater will be treated as discussed previously and discharged to Erdman Brook through a SPDES-permitted outfall after confirmation that radioactivity concentrations are acceptably low. The groundwater extraction wells will be removed during the excavation. **Excavated soil in the saturated zone will be segregated like excavated soil removed from the vadose zone to the extent practicable in accordance with the Waste Management Plan.**

**Groundwater accumulating in the excavation will be pumped out, treated as necessary at the Low-Level Waste Treatment Facility or using a portable treatment system containing ion exchangers and filters, and discharged to Erdman Brook through an SPDES-permitted outfall.**

Soil will be excavated to a depth of at least one foot into the Lavery till, with the extent of additional soil removal determined by the use of the cleanup goals specified in the Section 5. Remedial action surveys will be performed during the course of the work and soil on the bottom and sides of the excavation with radioactivity concentrations exceeding the cleanup goals will be removed and disposed of offsite as radioactive waste.<sup>8</sup> Contaminated soil with radioactivity concentrations below cleanup goals will be removed where practical, consistent with the ALARA process as described in Section 6 and Section 7.2.2. Soil will be excavated as close to the hydraulic barrier wall as practical. The other sides of the excavation will have a slope of approximately 45 degrees.

#### **Removal of Underground Structures, Floor Slabs, and Foundations**

The demolition of below-grade cells and structures shown in Figure 7-5 will be coordinated with the removal of the three underground tanks, the underground piping, and contaminated soil associated with the source area of the north plateau groundwater plume. All remaining concrete floor slabs and foundations in the area, including those outside of the excavation, will be removed early in the process to facilitate the excavation work. After soil is excavated to expose their structures, the below-grade cells will be demolished with conventional demolition equipment such as diamond wire saws.

The foundation pilings supporting the Process Building will be cut off at the bottom of the excavation or slightly below the bottom and the cut-off portion removed as well. All demolition debris will be characterized and disposed of offsite. In connection with this work, samples of soil will be collected around representative pilings, including at points several feet below the surface **in accordance with the Characterization Sample and Analysis Plan and the Phase 1 Final Status Survey Plan.** Analytical data from the samples will be used to evaluate the potential for preferential flow paths around the pilings and be considered in the Phase 1 final status surveys described in Section 9 **and Appendix G.**

**If sampling were to identify elevated activity exceeding cleanup goals in the till material adjacent to the pilings, actions will be taken to ensure that these exceedences are addressed (e.g., continued soil excavation around the pilings).**

---

<sup>8</sup> It is unlikely that the sides of the excavation that are not hydraulically downgradient will be contaminated. In any case, the extent of soil remediation on the sides of the excavation will be limited by the excavation boundaries. That is, any soil found to exceed the cleanup goals will be removed only within the confines of the downgradient hydraulic barrier wall and the sheet piles installed on the other sides of the excavation.



### Removal of Underground Tanks and Piping

The three underground tanks and **all** radioactively contaminated underground piping within the excavated area will be removed and disposed of as radioactive waste. Planning for underground line removal will take into account one line of particular interest: waste transfer line 7P120-3, which is expected to contain high levels of residual radioactivity as described in Section 4.1. The concrete off-gas trench will be removed. (Removal of the piping in the trench was provided for in Section 7.3.5.)

Duriron wastewater piping under the Process Building and east of the building, which contains lead in the piping joints, will be cut near the joints, with pieces containing the joints being disposed of as mixed waste. The remainder of this piping will be disposed of as LLW.

This process will apply to radioactive lines and also to nonradioactive sanitary lines and utility lines, which will be removed during the course of the work because it is unlikely that it will be practicable to leave them in place. Underground piping outside of the excavation will remain in place.

#### 7.3.9 Site Restoration

Once the below-grade structures of the Process Building and Vitrification Facility, the three wastewater tanks, the underground piping, and the remaining concrete floor slabs and foundations have been removed, and the underlying contaminated soils associated with the source area of the north plateau groundwater plume have been removed, a Phase 1 final status survey will be performed in the excavation bottom and sides as specified in Section 9 to verify that residual radioactivity levels are below the cleanup goals. Special attention will be paid to areas around the remaining sections of the Process Building support pilings. Surveys performed around the support pilings will extend to sufficient depth to evaluate the extent, if any, of the downward migration of contamination along the pilings. Arrangements will also be made for an independent **confirmatory** survey to be performed on behalf of the regulatory agencies.

After the **confirmatory** survey is completed and regulatory **concurrence** is received, the area will be backfilled with uncontaminated earth and graded as necessary to restore to it a near natural appearance. The backfill material will be obtained from similar offsite geologic deposits. The properties of this material (especially the texture, hydraulic conductivity, and distribution coefficients) will be similar to those of the sand and gravel layer on the project premises as described in Section 3.

A French drain will be emplaced during backfilling of the excavation to prevent groundwater from mounding near the hydraulic barrier wall. Water from the French drain will be allowed to passively discharge into a small tributary of Erdman Brook. More detail on the French drain design appears in Appendix D.

The sheet pilings installed on the upgradient sides of the excavation will be removed after the excavation is backfilled. The piling and any confinement structure used will be disposed of offsite at appropriate waste disposal facilities. **Figure 7-9 provides a conceptual cross-section view of the backfilled excavation. The cross section in this figure is similar to Section 7-8, that is, Section A-A on Figure 7-6,**



## WVDP PHASE 1 DECOMMISSIONING PLAN

Appendix D addresses monitoring and maintenance of the WMA 1 area **after** completion of Phase 1 of the decommissioning. Appendix D also provides information on expected changes to the groundwater flow field that will occur with completion of the Phase 1 decommissioning activities in WMA 1.

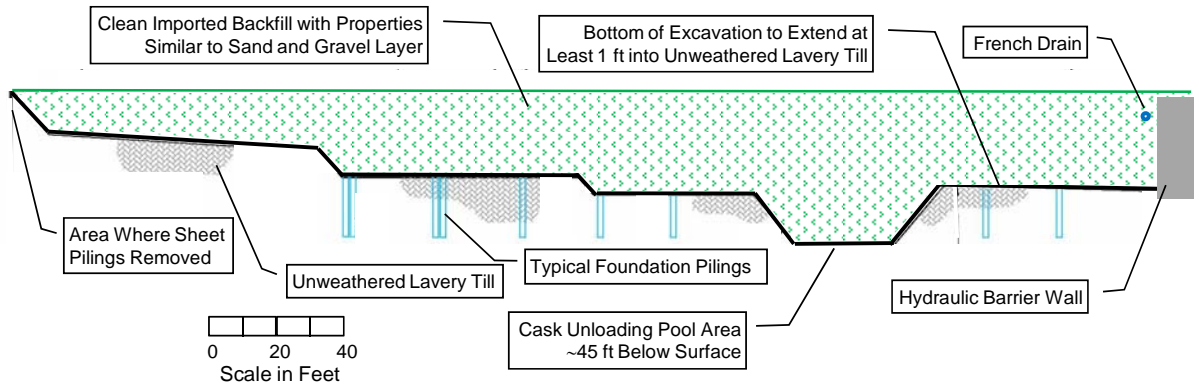

**Figure 7-9. Conceptual Cross-Section View of the Backfilled WMA 1 Excavation**

### 7.4 WMA 2 Decommissioning Activities

This section addresses decommissioning of the Low-Level Waste Treatment Facility area, **WMA 2**, which is shown in Figure 7-10.

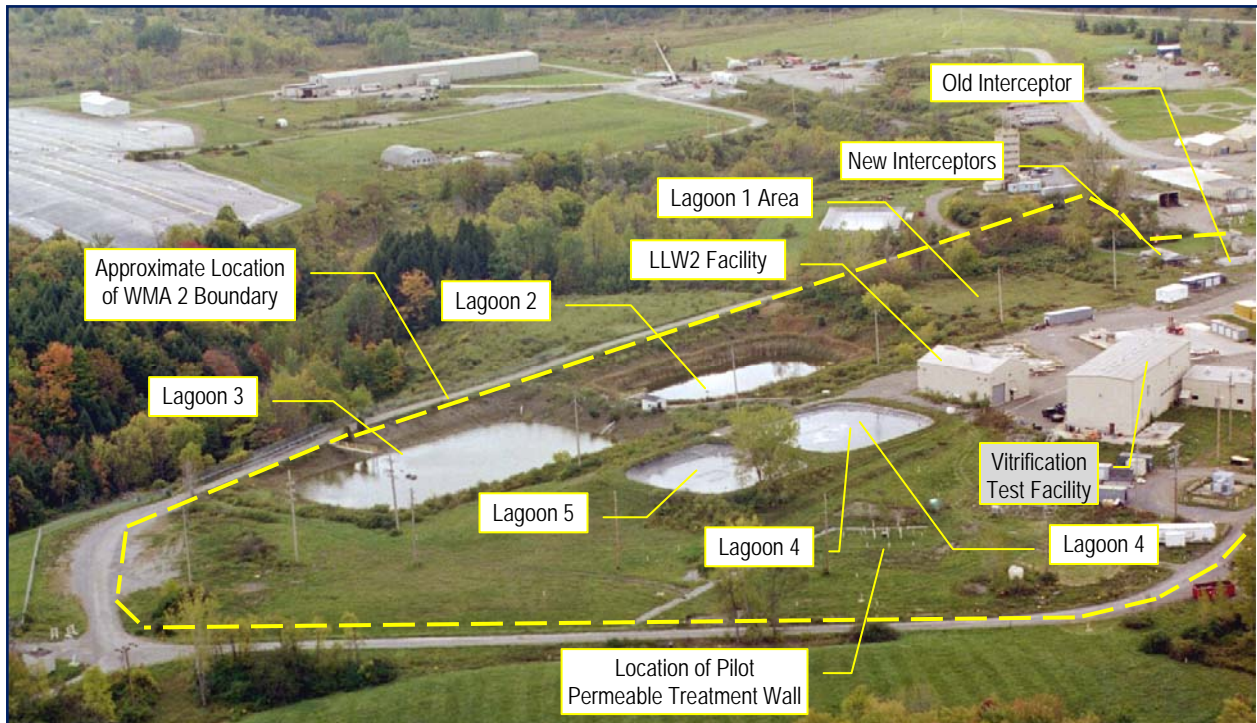

**Figure 7-10. WMA 2 in 2007**

The sequence for the Phase 1 decommissioning activities in WMA 2 will be developed during detailed planning. The LLW2 facility will be kept in service until it is no longer needed to treat the

## WVDP PHASE 1 DECOMMISSIONING PLAN

water in the lagoons and contaminated groundwater removed from the excavation before it is discharged through an SPDES-permitted outfall into Erdman Brook.

Demolition debris, soil, sediment, and other material removed during this work will be characterized for waste management purposes and disposed of at appropriate offsite waste disposal facilities. Absorbents will be added as necessary to containers of wet contaminated soil to absorb moisture.

### 7.4.1 Characterizing Soil and Sediment

Soil and sediment in WMA 2 will be characterized for residual radioactivity in accordance with the Characterization Sample and Analysis Plan described in Section 9. The results of this effort will be used in planning the excavation work described below. (This characterization will not include subsurface soil in areas impacted by the north plateau groundwater plume except in the portion of WMA 2 where the excavation will be located.)

### 7.4.2 Removing Structures

The structures in WMA 2 will be removed with appropriate radiological controls, along with the remaining concrete floor slabs and foundations. Removal of the Neutralization Pit, the Old Interceptor, the New Interceptors, and Lagoons 1, 2, and 3 will be coordinated with digging the WMA 2 excavation addressed in Section 7.4.3, which will encompass the area of these facilities as well as the Solvent Dike. During this process, characterization measurements will be taken in the end of each underground line that will remain in place and the line capped.

### LLW2 Facility

This metal-sided building with skid-mounted process equipment and a 900-gallon stainless steel lined sump is expected to contain low levels of radioactive contamination. Its demolition will involve activities such as the following:

- Removing the process equipment;
- Removing any water in the sump, stabilizing it in cement for disposal as LLW;
- Demolishing the structure to grade level;
- Removing the floor slab and foundation and the sump liner;
- Removing soil under the floor slab and foundation to a depth of approximately two feet<sup>9</sup>;
- Performing **radiological** status surveys in the area excavated for these purposes;
- Making arrangements for any independent confirmatory surveys to be performed in the excavated area; and
- Filling in the excavated area with clean earthen backfill.

---

<sup>9</sup> The two-foot prescriptive excavation depth was selected to avoid unnecessary excavation into soil contaminated by the north plateau groundwater plume during Phase 1 of the decommissioning. As noted previously, the plume will be among the sources considered in Phase 2 of the decommissioning.

---

### Neutralization Pit

The Neutralization Pit will be removed using a process similar to the following:

- Removing any residual water, treating it for disposal via an SPDES-permitted outfall or solidifying it for disposal as LLW; and
- Removing the liner, concrete walls, and floor of the pit.

The underground wastewater lines in the area of the Neutralization Pit will be removed in connection with digging the WMA 2 excavation described in Section 7.4.3. Phase 1 final status surveys, independent confirmatory surveys, and filling the excavation are also addressed in Section 7.4.3.

### Old Interceptor

The Old Interceptor will be demolished using a process similar to that used for the Neutralization Pit, with additional radiological controls appropriate to the larger amount of residual radioactivity it contains.

### New Interceptors

The New Interceptors will be demolished using a process similar to that used for the Neutralization Pit.

### Concrete Floor Slabs and Foundations

The concrete floor slabs of the O2 Building, Test and Storage Building, Vitrification Test Facility, Maintenance Shop, Maintenance Storage Area, and the Vehicle Maintenance Shop will be removed and the building footprints excavated approximately two feet below grade. **Radiological status** surveys will be performed in the excavated areas, and arrangements made for an independent **confirmatory** survey if desired by the regulators. After the surveys have been completed, the excavations will be filled with **clean earthen backfill**.

### 7.4.3 Decommissioning the Lagoons

Decommissioning of Lagoons 1, 2, and 3 will involve constructing a vertical hydraulic barrier on the northwest **and northeast** sides of the lagoons and digging a single large excavation. Lagoons 4 and 5 will be removed separately. Figure 7-11 shows the conceptual plan view of the large excavation and the location of the hydraulic barrier wall. Figure 7-12 shows the conceptual cross section.

# WVDP PHASE 1 DECOMMISSIONING PLAN

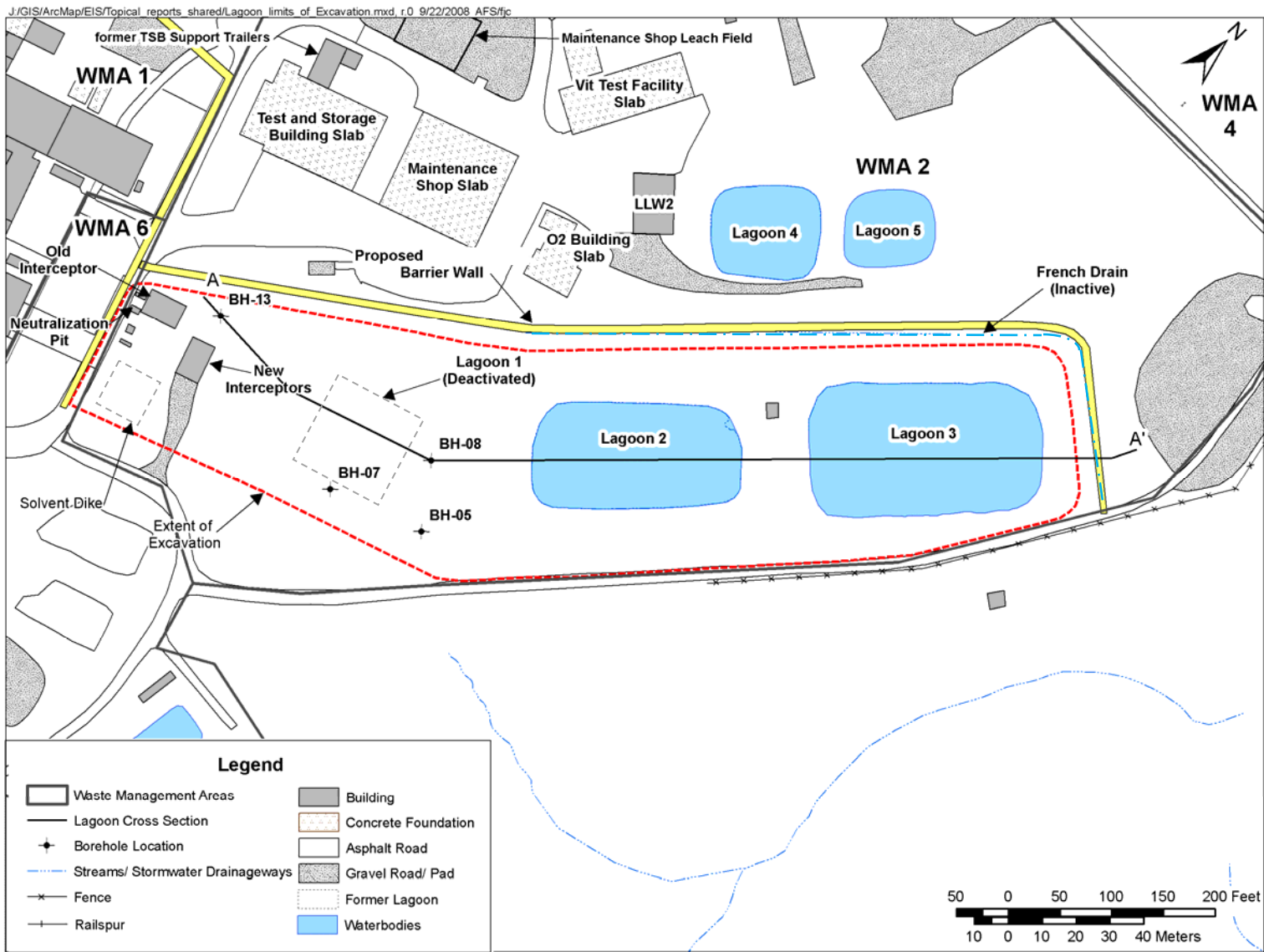

**Figure 7-11. Conceptual Arrangement of WMA 2 Excavation, Plan View**

# WVDP PHASE 1 DECOMMISSIONING PLAN

J:/GIS/ArcMap/EIS/Lagoon\_Cross\_Section\_A\_r1.mxd 2/04/2009 JRL/jfc

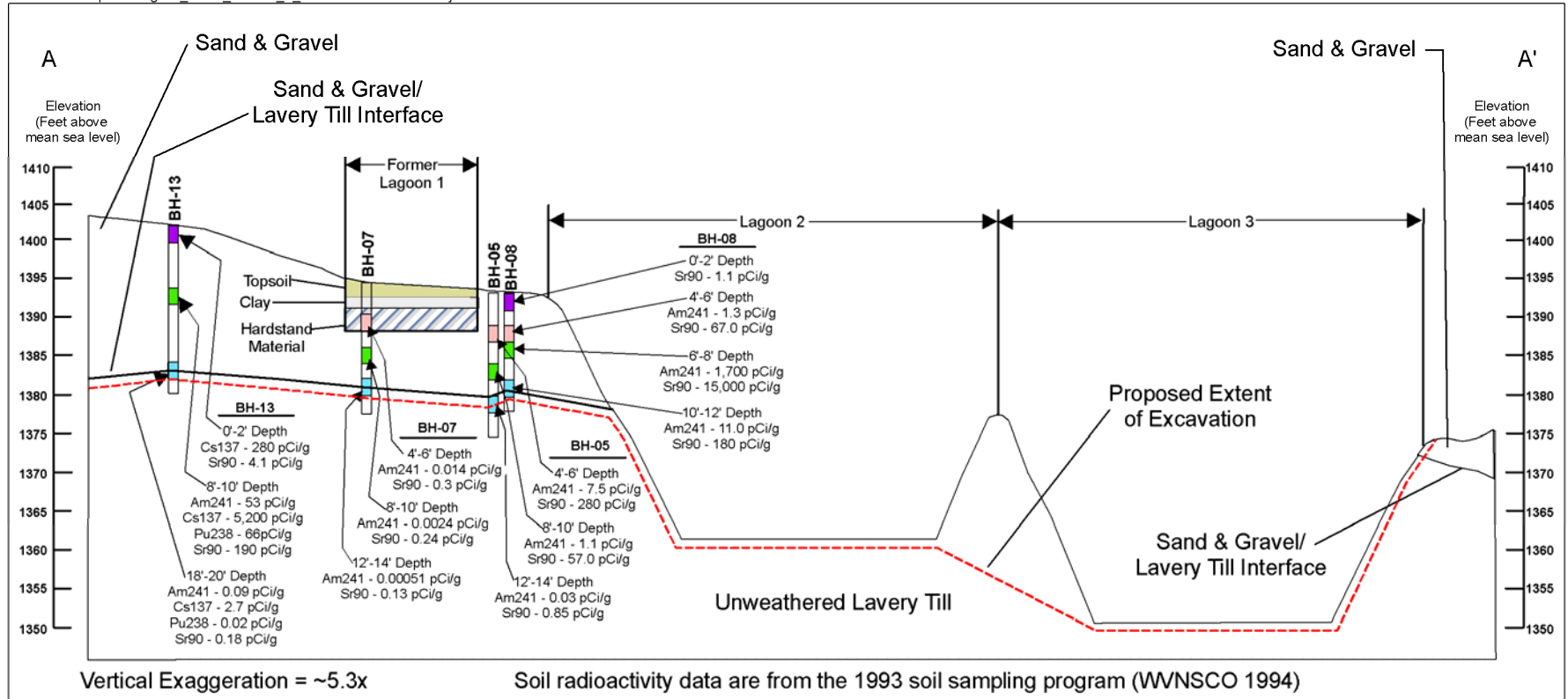

**Figure 7-12. Conceptual Arrangement of WMA 2 Excavation, Cross Section**



### Hydraulic Barrier Wall Installation

To isolate the area of WMA 2 to be excavated from the north plateau groundwater plume, a vertical hydraulic barrier wall will be installed as shown in Figure 7-11. This hydraulic barrier will consist of a soil-cement-bentonite barrier wall that will extend approximately two feet into the Lavery till. It will remain in place after the excavation is backfilled.

Before the hydraulic barrier wall is installed, underground lines in its footprint that carried radioactive liquid will be located. Sections of these lines in the area where the wall will be constructed will be removed in a controlled manner to avoid unnecessary release of contamination. During this process, characterization measurements will be taken in the end of each line that will remain in place and the line capped.

The total length of the barrier wall will be approximate 1100 feet. It will be sufficiently wide to provide the stability necessary to permit excavation up to the base of the wall. This barrier wall will connect with the WMA 1 hydraulic barrier wall as shown in Figure 7-11. It will be constructed in the same manner as the WMA 1 slurry wall and have an in-place maximum saturated hydraulic conductivity of approximately  $6E-06$  cm/s. It will extend to within about three feet of grade and be topped with **clean earthen backfill**. Sheet piles on the southeastern side of the excavation are not expected to be necessary to control groundwater, except possibly in the Lagoon 1 area as indicated below.

### Preparations for Removal of Contaminated Lagoon Sediment and Soil

Detailed planning for the excavation will take into account available information on radioactivity in the lagoon sediment, soil, and groundwater as summarized in Section 4, along with the results of the soil **and sediment** characterization program. The depth of the water table in the area – typically about seven feet below the surface – will also be taken into account.

Preparations, in addition to installation of the hydraulic barrier wall, will include provisions for appropriate radiological controls to minimize airborne radioactivity releases during the excavation work, such as a single-span confinement structure for the Lagoon 1 area.

### Removal of Contaminated Soil and Underground Wastewater Lines

Removal of Lagoons 1, 2, and 3 and the facilities within the area **of the large excavation** as described below will be coordinated with removal of soil in other parts of the excavation. Before excavation begins, the hydraulic barrier wall will be installed. **Extraction wells to dewater the excavation will be installed as with the WMA 1 excavation. Water removed by the wells will be treated as necessary – such as by use of a portable wastewater treatment system with ion exchangers and filters – and discharged to Erdman Brook through a SPDES-permitted outfall.**

The excavation process will be accomplished in two phases using conventional excavation equipment. The first phase will involve removal of soil in the vadose zone. It is expected that approximately one-half of the total amount of soil to be removed will be unsaturated. **As with the WMA 1 excavation, characterization data will be used to determine the portion of the excavated soil that it likely to be uncontaminated and these data, supplemented by in-process survey data collected as specified in Section 9, will be used to segregate the excavated soil that is unlikely to be contaminated from that which has been determined to be contaminated in accordance with the**

**Waste Management Plan. All soil removed from the excavation will be disposed of at appropriate offsite disposal facilities.**

The second phase will involve removal of soil in the saturated zone. Wastewater piping within the excavated area will be removed. Groundwater accumulating in the excavation will be pumped out, treated **as necessary** using a portable treatment system containing ion exchangers and filters, and discharged to Erdman Brook through an SPDES-permitted outfall.

Figure 7-12 shows the planned depth of excavation. The excavation will extend at least one foot into the Lavery till and one foot below the sediment in the bottoms of Lagoons 2 and 3 as indicated in the figure, with the amount of additional soil removal determined by the use of cleanup goals specified in Section 5.<sup>10</sup> Remedial action surveys will be performed during the course of the work and soil on the bottom and sides of the excavation with radioactivity concentrations exceeding the cleanup goals will be removed. Soil with radioactivity concentrations exceeding cleanup goals will be excavated **up to and into** the hydraulic barrier as practicable. However, the lateral extent of the remediation will not exceed the boundary shown in Figure 7-11 during Phase 1. **All removed equipment and excavated soil will be disposed of offsite at appropriate disposal facilities.**

### **Lagoon 1**

Lagoon 1 during operation was approximately 82 feet by 82 feet by five feet deep. It now contains radioactively contaminated sediment, asphalt, soil and vegetation and is capped with clay and covered with topsoil.

Sheet piles will be installed around Lagoon 1 as necessary to control groundwater flow into the area to be excavated. The excavation will be dug to encompass an area roughly 100 feet by 100 feet and extend approximately two feet into the Lavery till, with a total depth of approximately 14 feet. The clay cap, hardstand waste, and contaminated sand and gravel underlying Lagoon 1 will be excavated, along with the underlying sediment. The excavation will extend at least one foot into the underlying Lavery till, with the cleanup goals specified in Section 5 being used to determine the need for any additional soil removal. Phase 1 final status surveys will be performed in the excavated area and arrangements will be made for independent confirmatory surveys before the excavation is filled in, as described below. (These surveys will be performed when the entire WMA 2 excavation has been completed.)

**Any sheet piles installed to facilitate excavation of Lagoon 1 will be removed after the lagoon is excavated and disposed of offsite at appropriate disposal facilities.**

### **Lagoon 2**

As indicated previously, Lagoon 2 is an unlined basin approximately 280 feet long, 195 feet wide, and 17 feet deep with a significant amount of radioactive contamination in the bottom sediment.

Water in the lagoon will be treated in the LLW2 Facility and discharged through an SPDES-permitted outfall into Erdman Brook. Auxiliary equipment such as piping in the pump shed and the shed itself will be removed. Contaminated lagoon sediment will be removed along with at least one

---

<sup>10</sup> Note that Figure 7-12 shows the interface between the sand and gravel unit and the Lavery till in the area of Lagoon 1; Lagoon 2 and Lagoon 3 extend well into the Lavery till.



foot of underlying Lavery till, with the cleanup goals specified in Section 5 being used to determine the extent of any additional soil removal. As with Lagoon 1, Phase 1 final status surveys will be performed in the excavated area and arrangements will be made for independent confirmatory surveys before the excavation is filled in, as described below.

### **Lagoon 3**

As indicated previously, Lagoon 3 is an unlined basin similar in design to Lagoon 2, but 24 feet deep rather than 17 feet deep, with low level radioactivity in the sediment. It will be decommissioned using the same process as Lagoon 2.

### **Solvent Dike**

Radioactively contaminated soil in the Solvent Dike area will be removed before the large excavation is dug. This sequence will facilitate management of any unexpected wastes that might be present.

### **Other Parts of the Excavation**

Removal of soil in between the facilities in the area to be excavated will be coordinated with excavation of the facilities themselves so that the entire area is excavated as indicated in Figures 7-11 and 7-12, with the excavation extending at least one foot into the Lavery till. Any sheet piles installed to facilitate excavation of Lagoon 1 will be removed after that lagoon is excavated.

### **Surveying and Backfilling the Excavation**

Phase 1 final status surveys will be performed in the bottom and sides of the excavation to verify that the cleanup goals have been achieved and arrangements made for independent confirmatory surveys. After these surveys are completed and any issues resolved, the excavation will be filled with **clean** earthen backfill and the surface leveled with the surrounding area. The backfill material will be obtained from similar offsite geologic deposits. The properties of this material will be similar to the backfill used in the WMA 1 excavation.

### **Lagoons 4 and 5**

Lagoons 4 and 5 are similar above-grade lagoons that were constructed in 1971 from till material. Lagoon 4 has a capacity of 204,000 gallons and Lagoon 5 has a capacity of 166,000 gallons. Both are now lined with concrete grout and geomembranes. Low levels of radioactive contamination are expected in sediment both above and below the lagoon liners.

The **residual water, the geomembranes, and the concrete and clay liners** in Lagoons 4 and 5 will be removed and underlying soil excavated to a maximum depth of two feet. **Water pumped out of the lagoons will be treated and discharged through an SPDES-permitted outfall. The geomembranes, liners, and excavated soil will be disposed of at appropriate offsite disposal facilities.** After completion of this work, a **radiological** status survey will be performed in the area, and arrangements made for any independent **confirmatory** surveys **required** by the regulators. The excavated area will be filled with clean earth after the surveys.

**Final Condition of the Backfilled Excavation**

Figure 7-13 shows a conceptual cross-section view of the backfilled excavation. The location of this cross section is similar to the A-A section shown on Figure 7-12, except that it passes through the area of the interceptors on the southwest side of the excavation.

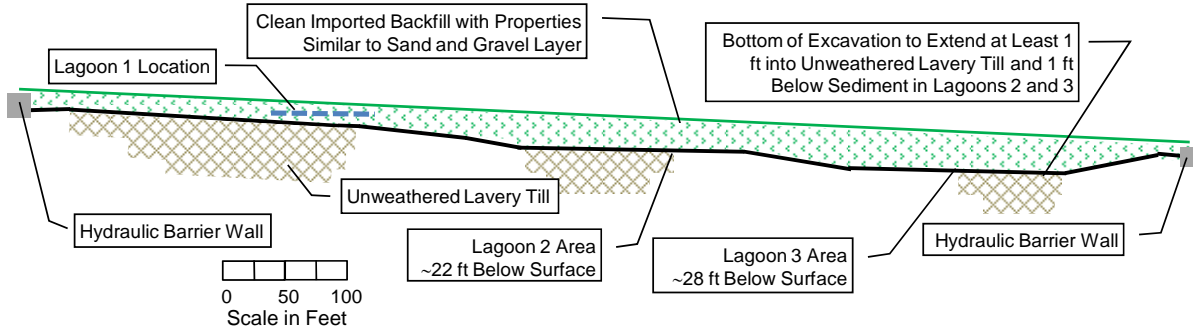

**Figure 7-13. Conceptual Cross-Section View of the Backfilled WMA 2 Excavation**

Appendix D addresses monitoring and maintenance of the WMA 2 area after completion of Phase 1 of the decommissioning. Appendix D also provides information on expected changes to the groundwater flow field that will occur with completion of the Phase 1 decommissioning activities in WMA 2.

**7.5 WMA 3 Decommissioning Activities**

This section addresses decommissioning activities in the Waste Tank Farm area, which include removal of two structures, piping and equipment in the HLW transfer trench, and the mobilization pumps, transfer pumps, and submersible pumps in the underground waste tanks, along with requirements for continuing maintenance of the underground waste tanks. WMA 3 is shown in Figure 3-29.

**7.5.1 Removing Structures**

The Con-Ed Building and the Equipment Shelter and Condensers will be removed with appropriate radiological controls and the resulting demolition debris characterized and disposed of at an appropriate offsite disposal facility. These facilities are expected to have low levels of residual radioactivity, mostly inside installed equipment.

**Con-Ed Building**

This small concrete block building located over the Tank 8D-3/8D-4 vault will be removed by removing the installed equipment, demolishing the structure to grade level, and performing radiological status surveys in the area of the building footprint.

**Equipment Shelter**

This concrete-block building – which is approximately 40 feet long, 18 feet wide, and 12 feet high – will be removed using a process similar to that used for the Con-Ed Building. The condensers will also be removed and disposed of at an offsite waste disposal facility. Soil in the footprints of the building and condenser foundations will be removed to a maximum depth of two feet below grade. Radiological status surveys will be performed in the excavated areas and

arrangements made for any independent confirmatory surveys **required by the regulators.** Afterwards, the excavated areas will be filled with clean earthen backfill.

### 7.5.2 Removing Waste Tank Pumps and Pump Support Structures

As noted previously, Tank 8D-1 contains five HLW mobilization pumps and Tank 8D-2 contains four of these centrifugal pumps. Tanks 8D-1 and 8D-2 also each contain a HLW transfer pump. Each pump has an overall length of more than 50 feet and contains significant amounts of radioactive contamination. Figure 3-32 shows both pump designs. Figure 3-34 shows a typical pump pit. As noted in Section 3, Tanks 8D-1 and 8D-2 each contain another suction pump and Tanks 8D-3 and 8D-4 are each expected to contain a small submersible pump.

The HLW mobilization and transfer pumps have been impacted by liquid HLW. DOE will follow applicable provisions of DOE Manual 435.1-1, *Radioactive Waste Management Manual*, concerning these pumps.

The HLW mobilization pumps, transfer pumps, and suction pumps will be removed and disposed of offsite using a process such as the following:

- Preparations will be made for handling the removed pumps in a controlled manner consistent with their expected high radiation and contamination levels and the expected waste classification of different parts of the pump assembly;
- Each pump will be removed using appropriate radiological controls, decontaminated as necessary, cut into sections during removal, and packaged for disposal;
- The pump support structures will be removed in conjunction with removal of the pumps; and
- The pump segments and the support structures will be disposed of offsite at appropriate waste disposal facilities.

The submersible pumps in Tanks 8D-3 and 8D-4 will also be removed using appropriate radiological controls and disposed of offsite as radioactive waste.

### 7.5.3 Removing HLW Transfer Trench Piping and Equipment

As noted previously, the HLW transfer trench, which is shown in Figure 3-33, is approximately 500 feet long, extending from the Tank 8D-3/8D-4 vault to the Vitrification Facility. The trench contains lines comprising approximately 3000 linear feet of double-walled stainless steel pipe. Each pump pit contains a waste transfer pump (which will be removed as specified in Section 7.5.2), discharge piping, and flow monitoring equipment; Pump Pit 8Q-2 also contains grinding equipment that was used to size reduce contaminated zeolite. The inner piping, valves, and the other equipment are expected to contain significant radioactive contamination.

The piping that was actually used and some of the other equipment were wetted by liquid HLW **and may contain significant amounts of residual radioactivity.** DOE will follow **the** applicable provisions of DOE Manual 435.1-1, *Radioactive Waste Management Manual* concerning the piping **and the** other equipment.

The piping and other equipment will be removed using a process such as the following:

## WVDP PHASE 1 DECOMMISSIONING PLAN

- Preparations will be made for handling the removed piping and other equipment in a controlled manner consistent with their expected high radiation and contamination levels;
- The piping will be cut into sections and packaged for disposal;
- The other equipment will be removed, segmented as necessary, and packaged for disposal, with this effort coordinated with removal of the piping and waste mobilization and transfer pumps; and
- The piping and other equipment will be disposed of offsite at an appropriate waste disposal facility.

After the piping has been removed, **radiological status** surveys will be performed in the empty transfer trench and the trench covers reinstalled.

### 7.5.4 Monitoring and Maintenance

Monitoring and maintenance of the Waste Tank Farm will continue during Phase 1 **of the** decommissioning and until such time that Phase 2 of the decommissioning begins. The tank and vault drying system installed during the work to establish the interim end state described in Section 3 will remain in operation.

The existing dewatering well will continue to be used to artificially lower the water table to minimize in-leakage of groundwater into the tank vaults. After the Low-Level Waste Treatment Facility is taken out of operation, the water from this well will be collected, sampled, treated if necessary using a portable wastewater treatment system, and **released through** a SPDES-permitted outfall.

Appendix D provides additional information on these matters.

## 7.6 WMA 5 Decommissioning Activities

This section addresses removal of Lag Storage Addition 4 **and the associated Shipping Depot**, the Remote-Handled Waste Facility, and remaining concrete floor slabs and foundations and gravel pads in WMA 5, the Waste Storage Area. Figure 3-35 shows this area. **These structures are not expected to have any contamination above the minimum detectable concentrations, except for the Remote-Handled Waste Facility, which may have low-level contamination in some areas and possibly higher levels of contamination in the Work Cell.**

### 7.6.1 Removing Lag Storage Addition 4 and the Shipping Depot

Lag Storage Addition 4, a clear-span structure with a pre-engineered frame and steel sheathing, is approximately 291 feet long, 88 feet wide, and 40 feet high. The attached steel framed, steel sided structure houses the Shipping Depot and Container Sorting and Packaging Facility.

These structures will be removed and the demolition debris disposed of at an appropriate off-site waste disposal facility using a process such as the following:

- Demolishing the structure to grade level;
- Removing the floor slab and excavating the building footprint to approximately two feet below grade;

## WVDP PHASE 1 DECOMMISSIONING PLAN

- Disposing of the demolition debris at appropriate offsite waste disposal facilities;
- Performing **radiological status** surveys in the area excavated;
- **Evaluating the resulting data and determining whether to perform Phase 1 final status surveys to establish that these areas meet the surface soil cleanup criteria;**
- **If Phase 1 final status surveys are to be performed, notifying NRC to this effect;**
- **Performing the Phase 1 status surveys, if they are to be accomplished;**
- **Arranging for any confirmatory surveys required by the regulators; and**
- After completion of the surveys, filling in the excavated area with clean earthen backfill.

### 7.6.2 Removing the Remote-Handled Waste Facility

This metal-sided, steel-frame building, which became operational in 2004, includes a receiving area, a buffer cell, a work cell, a waste packaging area, an operating aisle, and a load-out/truck bay. It is shown in Figures 3-36 and 3-37.

This facility is used to remotely section and package high-activity equipment and waste and is permitted as a mixed waste treatment and storage containment building. The closure of the facility under an approved Resource Conservation and Recovery Act closure plan will be coordinated with the demolition under this plan.

The Remote-Handled Waste Facility will be removed using a process such as the following:

- Removing the installed equipment such as the cranes and tanks;
- Demolishing the structure to grade level;
- Removing the floor slab and foundation, removing the below-grade part of the structure, and excavating the rest of the building footprint to approximately two feet below grade;
- Disposing of the demolition debris at appropriate offsite waste disposal facilities;
- Performing **radiological** status surveys in the area excavated;
- **Evaluating the resulting data and determining whether to perform Phase 1 final status surveys to establish that these areas meet the surface soil cleanup criteria;**
- **If Phase 1 final status surveys are to be performed, notifying NRC to this effect;**
- **Performing the Phase 1 status surveys, if they are to be accomplished;**
- **Arranging for any confirmatory surveys required by the regulators; and**
- After completion of the surveys, filling in the excavated area with clean earthen backfill.

The underground decontamination waste transfer lines from the Batch Transfer Tank in the building to Tank 8D-3 in WMA 3 will be removed and disposed of as LLW if they have been exposed to radioactivity; otherwise, they will remain in place.

### 7.6.3 Removing Remaining Floor Slabs and Foundations and Gravel Pads

All remaining concrete floor slabs and foundations will be removed, including those associated with the Lag Storage Building, Lag Storage Addition 1, and Lag Storage Addition 3. The Lag

Storage Addition 2 hardstand will also be removed, along with the gravel pads associated with the Chemical Process Cell Waste Storage Area, the hazardous waste storage lockers, the cold hardstand area, the vitrification vault and empty container hardstand, the old/new hardstand storage area, the lag hardstand, and the Product Purification Cell box storage area.

The remaining floor slabs, foundations, and gravel pads will be removed along with the underlying soil to approximately two feet below grade, with the debris and removed soil disposed of at appropriate offsite waste disposal facilities. This work will be followed by **radiological status** surveys of the excavated areas. **The resulting data will be evaluated and if it is determined to be appropriate, NRC will be notified that Phase 1 final status surveys will be performed in the area. These surveys will be performed as applicable. Arrangements will be made for any independent confirmatory surveys required by the regulators.** After all of the surveys have been completed, the excavations will be filled with **clean earthen backfill**.

#### **7.6.4 Establishing that Surface Soil Meets Cleanup Goals**

**Characterization data on surface soil and subsurface soil collected within WMA 5 will be evaluated. Based on this evaluation, parts of WMA 5 may be selected as appropriate for any necessary remediation and for Phase 1 final status surveys. These activities will be performed as specified in Section 7.11.**

### **7.7 WMA 6 Decommissioning Activities**

This section addresses decommissioning activities in WMA 6, the Central Project Premises, which is shown in Figure 3-38. These activities involve removal of the Sewage Treatment Plant, the south Waste Tank Farm Test Tower, the two demineralizer sludge ponds, the equalization basin, and the equalization tank. The demolition debris and the removed soil will be disposed of at appropriate offsite disposal facilities.

#### **7.7.1 Removing the Sewage Treatment Plant**

This wood frame structure with metal siding and roofing was used to treat sanitary waste and contains six in-ground concrete tanks, one above-ground polyethylene tank, and one above-ground stainless steel tank. This facility will be completely removed, including the underground concrete tanks, with the concrete foundation and underlying soil removed approximately two feet below grade. **It is not expected to be radioactively contaminated.**

After completion of this work, a **radiological status** survey will be performed in the excavated area. **The resulting data will be evaluated, taking into account experience with buildup of natural and manmade radioactivity in sewage sludge (ISCORS 2005), and if it is determined to be appropriate, NRC will be notified that Phase 1 final status surveys will be performed in the area. These surveys will be performed as applicable, and arrangements will be made for any independent confirmatory surveys required by the regulators.** After completion of all of the surveys, the excavated area will be filled with **clean earthen backfill**.

#### **7.7.2 Removing the Equalization Basin**

The equalization basin is an earthen basin lined with Hypalon<sup>®</sup> approximately 50 feet by 125 feet by seven feet deep that has served as a replacement for the demineralizer sludge ponds. **It is not expected to be radioactively contaminated.**

The liner and approximately two feet of underlying soil will be removed and disposed of offsite. After completion of this work, a **radiological status** survey will be performed in the area. **The resulting data will be evaluated and if it is determined to be appropriate, NRC will be notified that Phase 1 final status surveys will be performed in the area. These surveys will be performed as applicable and arrangements will be made for any independent confirmatory surveys required by the regulators.** After completion of **all** of the surveys, the area will be filled with **clean earthen backfill**.

#### **7.7.3 Removing the Equalization Tank**

The Equalization Tank is a 20,000-gallon underground concrete tank immediately north of the Equalization Basin that serves as a replacement for the Equalization Basin. **It is not expected to be radioactively contaminated.**

The tank will be demolished and approximately two feet of underlying soil removed, with this material disposed of offsite. After completion of this work, a **radiological status** survey will be performed in the area. **The resulting data will be evaluated and if it is determined to be appropriate, NRC will be notified that Phase 1 final status surveys will be performed in the area. These surveys will be performed as applicable. Arrangements will be made for any independent confirmatory surveys required by the regulators.** After completion of **all** of the surveys, the area will be filled with **clean earthen backfill**.

#### **7.7.4 Removing the Demineralizer Sludge Ponds**

The north and south demineralizer sludge ponds are separate, unlined basins excavated in the sand and gravel layer that are known to contain low-level radioactive contamination.

The area of the ponds will be excavated to a total depth of approximately five feet, with the material removed being disposed of offsite at an appropriate waste disposal facility. After completion of this work, a **radiological status** survey will be performed in the area. **The resulting data will be evaluated and if it is determined to be appropriate, NRC will be notified that Phase 1 final status surveys will be performed in the area. These surveys will be performed as applicable. Arrangements will be made for any independent confirmatory surveys required by the regulators.** After completion of **all** of the surveys, the area will be filled with **clean earthen backfill**.

#### **7.7.5 Removing the South Waste Tank Farm Test Tower**

This test tower **is not expected to be radioactively contaminated.** It will be removed, including its concrete foundation and underlying soil to approximately two feet below grade, with the debris and soil disposed of offsite. After completion of this work, a **radiological status** survey will be performed in the area. **The resulting data will be evaluated and if it is determined to be appropriate, NRC will be notified that Phase 1 final status surveys will be performed in the area. These surveys will be performed as applicable. Arrangements will be made for any independent confirmatory surveys required by the regulators.** After completion of **all** of the surveys, the area will be filled with **clean earthen backfill**.

#### **7.7.6 Removing the Remaining Floor Slabs and Foundations**

The remaining floor slabs and foundations in the area – including the underground structure of the Cooling Tower– will be removed, with underlying soil removed to a maximum depth of two feet



below grade. After completion of this work, a **radiological status** survey will be performed in the area. The resulting data will be evaluated and if it is determined to be appropriate, NRC will be notified that Phase 1 final status surveys will be performed in the area. These surveys will be performed as applicable. Arrangements will be made for any independent **confirmatory** surveys required by the regulators. After completion of all of the surveys, the area will be filled with **clean earthen backfill**.

#### **7.7.7 Establishing that Surface Soil Meets Cleanup Goals**

Characterization data on surface soil and subsurface soil collected within WMA 6 will be evaluated. Based on this evaluation, parts of WMA 6 may be selected as appropriate for any necessary remediation and for Phase 1 final status surveys. These activities will be performed as specified in Section 7.11.

### **7.8 WMA 7 Decommissioning Activities**

WMA 7, the NDA area, is shown in Figure 3-41. The NDA will continue to be monitored and maintained during Phase 1 and no decommissioning actions related to the NDA itself will take place in this phase of the decommissioning. The only Phase 1 decommissioning actions will involve removal of the remaining concrete slabs and gravel pads associated with the NDA hardstand.

These concrete slabs and gravel pads will be removed and the footprints of these areas will be excavated to a maximum of depth two feet below grade, with the debris and excavated materials disposed of **at appropriate** offsite **disposal facilities**. **Radiological status** surveys will be performed in the excavated areas and arrangements made for any independent **confirmatory** surveys required by the regulators. After completion of the surveys, these areas will be filled with **clean earthen backfill**.

### **7.9 WMA 9 Decommissioning Activities**

This section describes decommissioning activities in the Integrated Radwaste Treatment System Drum Cell area, which is shown in Figure 3-42. Phase 1 decommissioning activities in this area will involve removal of the Drum Cell, the trench soil container area, and the subcontractor maintenance area. **The Drum Cell is not expected to have any contamination above minimum detectable concentrations, nor are the other areas.**

The Drum Cell is a pre-engineered metal building 375 feet long, 60 feet wide, and 26 feet high, with concrete shield walls, remote waste handling equipment, container storage areas, and a control room. It will be demolished by conventional means and the floor slab, gravel pad, and foundation removed, along with underlying soil to at least two feet below grade. After completion of this work, a **radiological status** survey will be performed in the excavated area. **The resulting data will be evaluated and if it is determined to be appropriate, NRC will be notified that Phase 1 final status surveys will be performed in the area. These surveys will be performed as applicable. Arrangements will be made for any independent confirmatory surveys required by the regulators. After completion of all of the surveys, the excavated area will be filled with clean earthen backfill.**

The trench soil container area is located northwest of the Drum Cell. The material in this area will be removed and its footprint excavated to a maximum depth of approximately two feet below grade, with the excavated materials disposed of offsite. **Radiological status** surveys will be performed in the excavated area. **The resulting data will be evaluated and if it is determined to be**



appropriate, NRC will be notified that Phase 1 final status surveys will be performed in the area. These surveys will be performed as applicable. Arrangements will be made for any independent confirmatory surveys required by the regulators. After completion of all of the surveys, the area will be filled with clean earth.

The subcontractor maintenance area, a gravel pad near the rail spur, will be removed using the process used for the trench soil container area.

Characterization data on surface soil, near surface soil, and subsurface soil collected within WMA 9 will also be evaluated. Based on this evaluation, parts of WMA 9 may be selected as appropriate for any necessary remediation and for Phase 1 final status surveys. These activities will be performed as specified in Section 7.11.

#### **7.10 WMA 10 Decommissioning Activities**

The Phase 1 decommissioning activities in this WMA, the support and services area, will consist of removing the New Warehouse and the remaining concrete floor slabs and foundations, along with the former Waste Management Storage Area. WMA 10 is shown in Figure 3-43.

The New Warehouse will be removed. This structure is 80 feet wide, 250 feet long, and 21.5 feet high and rests on concrete piers and a poured concrete foundation wall. It is not expected to be radiologically contaminated.

The New Warehouse will be demolished by conventional means and its foundation and the underlying soil removed to a maximum depth of approximately two feet below grade. After completion of this work, a radiological status survey will be performed in the excavated area. The resulting data will be evaluated and if it is determined to be appropriate, NRC will be notified that Phase 1 final status surveys will be performed in the area. These surveys will be performed as applicable. Arrangements will be made for any independent confirmatory surveys required by the regulators. After completion of all of the surveys, the excavated area will be filled with clean earthen backfill.

The remaining floor slabs and foundations in the area – including those for the Administration Building, the Expanded Environmental Laboratory, and the Fabrication Shop – will also be removed, with underlying soil removed to a maximum depth of approximately two feet below grade. The former Waste Management Storage Area will also be removed in the same manner. After completion of this work, a radiological status survey will be performed in each excavated area. The resulting data will be evaluated and if it is determined to be appropriate, NRC will be notified that Phase 1 final status surveys will be performed in the area. These surveys will be performed as applicable. Arrangements will be made for any independent confirmatory surveys required by the regulators. After completion of all of the surveys, the excavated areas will be filled with earthen backfill.

Characterization data on surface soil, near surface soil, and subsurface soil collected within WMA 10 will also be evaluated. Based on this evaluation, parts of WMA 10 may be selected as appropriate for any necessary remediation and for Phase 1 final status surveys. These activities will be performed as specified in Section 7.11.

The Meteorological Tower and the Security Gatehouse and fences will remain in place.

## **7.11 Establishing Areas Where Surface Soil Meets Cleanup Goals**

As discussed in the previous subsections, DOE may elect to establish that surface soil in selected areas of the project premises meets the surface soil cleanup goals. The areas of interest will be identified based on the results of the characterization program.

### **7.11.1 Areas of Interest**

These areas will have no subsurface radioactive contamination deeper than one meter (3.3 feet) from the surface based on process knowledge and characterization results and would be required to meet the surface soil cleanup goals. They may include areas where foundations and floor slabs are removed, areas where characterization shows residual radioactivity concentrations below the surface soil cleanup goals, and other areas where radioactive contamination exceeding the cleanup goals could be removed with relatively minor effort. They may also include areas to be used for temporary storage of excavated contaminated soil. Given these factors, not all of the areas of interest can be identified early in Phase 1 and in some cases any required remediation and the required Phase 1 final status surveys will necessarily take place late in Phase 1.

### **7.11.2 Process to be Followed**

The process would include steps such as the following if this effort is undertaken:

- The initial characterization program would be completed and the resulting data reviewed,
- The excavated soil laydown areas would be identified,
- The primary areas of interest would be selected and NRC notified,
- Each area of interest would be remediated as necessary to meet the surface soil cleanup goals,
- Phase 1 final status surveys would be performed,
- The applicable portions of the Phase 1 Final Status Survey Report would be prepared, and
- Arrangements will be made for any independent confirmatory surveys required by the regulators.

A similar process would be followed when building foundations and floor slabs are removed. The radiological status survey data would be evaluated and the decision made as to whether to establish that the area – in this case a shallow excavation about two feet deep – meets the surface soil cleanup goals. If the decision were to be made to do this, NRC would be notified, the Phase 1 final status surveys performed, the applicable portions of the Phase 1 Final Status Survey Report prepared, and arrangements made for any confirmatory surveys to be performed. The shallow excavation would be backfilled with clean earthen backfill only after all the surveys have been completed and any related issues resolved.

The Phase 1 Final Status Survey Report would document the final status surveys performed in these areas. In addition, one or more maps would be prepared to document the precise locations of all such areas and copies of these maps provided to NRC, NYSERDA, and NYSDEC. The areas would also be identified in an appropriate manner, such as by the use of fences and signs.

### 7.11.3 Additional Area of Interest

As shown in Figure 3-8, a small portion of WMA 12 lies within the project premises security fence. Any characterization data on surface soil and subsurface soil collected within this portion of WMA 12 will be evaluated. Based on this evaluation, parts of the portion of WMA 12 within the project premises may be selected for any necessary remediation and for Phase 1 final status surveys. These activities would be performed as specified above.

## 7.12 Remedial Technologies

A combination of conventional technologies and proven innovative technologies will be used to accomplish the decommissioning activities specified in the preceding sections. This section summarizes these technologies in the following categories:

- Pipe cutting and other metal cutting,
- Tool positioning,
- Concrete cutting and demolition,
- Concrete decontamination,
- Demolition of structures, and
- Excavation and grading

It is not the intention of this summary of remediation technologies to preclude the use of other, better technologies that may be developed, so long as they are comparable with and equivalent to those discussed here, nor is it DOE's intention to endorse the products of particular manufacturers beyond observations about cases where those products have been successfully used. More specific information on the technologies to be used will be provided in the Decommissioning Work Plan(s).

### 7.12.1 Pipe Cutting and Other Metal Cutting

The following methods will be used as applicable for cutting radioactively contaminated piping and metal liners, equipment, and structural components. Methods will be selected based on efficiency and suitability for the particular applications, with consideration of factors such as personnel safety, metal thickness, and radioactive contamination control. These technologies are listed in alphabetical order.

#### Diamond Wire Cutting Systems

This technology is suitable for cutting thick steel plate such as that which may be used in the shielded transfer cell in the Load-In/Load-Out Building. It is described below under Concrete Cutting and Demolition.

#### Duriron Pipe Cutting

Because Duriron is hard and brittle, Duriron wastewater piping is typically cut into sections using either a chain-type tool or a special tool provided by the piping manufacturer to score the pipe, and tapping it with a mallet to fracture it at the score mark.

### **Hand-Held Shear**

This technology, manufactured by Res-Q-Tek, Inc., cuts stainless-steel pipes up to 1.5 inches in diameter, and has been used at DOE's Fernald site. This shear can also crimp pipes to minimize potential spillage of pipe contents.

### **High-Speed Clamshell Pipe Cutter**

This technology can cut through large pipes up to 24 inches in diameter with minimal clearance requirements. This equipment is manufactured by Tri-Tool, Inc., and has been used at DOE's Hanford site.

### **Mega-Tech Hydraulic Shears**

This equipment, manufactured by Mega-Tech, Inc., can be used to cut stainless steel pipes up to 1.5 inches in diameter and has been used at Argonne National Laboratory.

### **Nd:YAG Laser**

A Lumonics two kilowatt neodymium-doped yttrium aluminum garnet (Nd:YAG) laser has been used to remotely size reduce about 300 fuel storage tubes and radioactively-contaminated converter shells from the former K-25 Gaseous Diffusion Plant site at Oak Ridge, Tennessee.

### **Nibblers**

Electric nibblers have been found effective in cutting sheet metal in many applications. They are readily available commercially.

### **Liquid Nitrogen Cutting**

A liquid nitrogen cutting and cleaning system such as that offered by Nitrocision<sup>®</sup> can be used to cut metal and decontaminate concrete without producing a secondary waste stream. This system can be used either manually or robotically and can be equipped with a vacuum capture system to collect decontamination debris. A Nitrocision<sup>®</sup> liquid nitrogen cutting and cleaning system is expected to be in operation in support of facility deactivation work at the WVDP in late 2009 or early 2010.

### **Pipe Cutting and Crimping System**

The Burndy Lightweight Portable Crimper is an electrically powered hydraulic crimping tool that cuts smaller-diameter piping by crimping and minimizes the potential spillage of piping contents. This equipment is manufactured by Burndy, Inc, and has been used at DOE's Mound facility.

### **Pipe Cutting and Isolation System**

This robotic technology developed by TPG Applied Technology consists of three tools: a pipe-cutting tool, a pipe-cleaning tool, and a pipe-plugging tool. This system has been used to cut pipes within storage tanks at the K-25 Plant at DOE's Oak Ridge site.

### **Powered Pipe Cutting Machines**

Air-powered pipe cutoff machines have been found effective by the U.S. Navy in cutting stainless steel piping of varying diameters.

### **Reciprocating Saws and Portable Band Saws**

Variable-speed electric reciprocating saws and portable band saws were found effective in cutting stainless steel piping and other metal shapes up to one-half inch thick during the decommissioning of the Barnwell Nuclear Fuel Plant. Effectiveness depends on blade type, cutting speed, and blade lubricant.

### **Roller Cutters**

Manually operated roller cutters have been found effective by the U.S. Navy on highly-contaminated, smaller diameter piping where radiological containment is required.

### **Size Reduction Machine**

The Mega-Tech Services size reduction machine has been used at DOE's Savannah River Site and is capable of hydraulically shearing piping from six feet below floor level to 15 feet above floor level. It can shear pipes up to four inches in diameter

### **Thermal Cutting Technologies**

Oxy-acetylene and oxy-gasoline cutting torches have been used to cut steel pipe and plate at DOE sites. The oxy-gasoline cutting torch is specially suited for cutting carbon-steel pipes and plates, and can cut steel up to 4.5-inch in thickness at a rate three times faster than oxy-acetylene cutting. This equipment is manufactured by Petrogen International, and has been used at DOE's Oak Ridge, Fernald, and Mound sites.

### **7.12.2 Tool Positioning Technologies**

The following three systems have been found to be useful at DOE sites:

#### **Dual Arm Work Platform**

The dual arm work platform is a remotely operated deployment platform that uses a variety of equipment to dismantle metal assemblies. Two Schilling Titan III manipulator arms provide six degrees of freedom, and are powered by a 3000 psi hydraulic system.

Each arm is capable of lifting 240 pounds, while the grippers on the end of the arms can exert 1,000 lbs of crushing force. The platform is designed to be free standing or suspended from an overhead crane. This system was used at the DOE CP-5 Research Reactor Large-Scale Demonstration Project at Argonne National Laboratory – East.

#### **Mobile Work Platform**

The Mobile Work Platform is a remote-controlled machine designed to remove pipe/conduit. A rotating turret is equipped with a folding main boom and a telescoping job boom capable of reaching 27 feet. The boom system can lift over four tons with the outriggers in place. With the dual crimper/shear attached to the jib boom, the reach extends out to 32 feet above the ground.

#### **Rosie - Mobile Work Platform**

Rosie evolved from the Remote Work Vehicle that supported cleanup work at the Three Mile Island nuclear power plant. The Rosie is a remotely operated, mobile work platform built by RedZone Robotics. It is a four-wheel drive, four-wheel steer locomotor that is capable of deploying

tools weighing up to 2,000 lbs to a height of 27 feet with a telescoping boom with various end effectors.

A control console allows a single operator to remotely manipulate Rosie using video and data displays. Video displays are provided by up to ten cameras mounted on Rosie, in addition to cameras mounted in the facility. During the demonstration at the CP-5 Research Reactor, Rosie was fitted with a jackhammer and used to remove high-density concrete from the reactor's upper shield plug.

### 7.12.3 Concrete Cutting and Demolition

#### Concrete Saws

Concrete saws such as those used during highway pavement maintenance have been used effectively in cutting out sections of concrete floors during nuclear facility decommissioning. They are available from various manufacturers with carbide and diamond-impregnated saw blades ranging up to 30 or more inches in diameter.

#### Remote Controlled Demolition Machines

Demolition machines have been used to remotely remove and size-reduce concrete, piping, and structural steel. The Brokk remote controlled demolition machines, such as the model shown in Figure 7-14 are manufactured by Holmhed Systems AB. They can be operated remotely with a hydraulic hammer, excavating bucket, concrete crusher, and a shear. The arm has a reach of 15 feet, and can be operated remotely at distances up to 400 feet.

One was used effectively in dismantling equipment in the Vitrification Cell during cell deactivation. These machines could be used in various places in the Process Building and Vitrification Facility.



Figure 7-14 Typical Demolition Machine

### **Diamond Wire Cutting Systems**

Diamond wire cutting utilizes diamond-impregnated wire to cut metal and concrete. The system uses a series of guide pulleys to draw the continuous wire strand through the cut. This technology has been used at numerous decommissioning projects, such as Fort St. Vrain, DOE's C Reactor Interim Safe Storage Project at the Hanford site (Trentec, Inc., Cincinnati, Ohio), and the Tokamak Fusion Test Vessel (Bluegrass Bit Co., Greenville, Alabama).

Diamond wire cuts through reinforced concrete, rebar, structural steel, and steel plate without generating large amounts of dust. The wire is cooled with either water collected in a sump, which controls any loose contamination generated during cutting, or with liquid nitrogen in situations where waste generation is a prime concern.

### **Jackhammers and Chipping Hammers**

Pneumatic jackhammers and chipping hammers have been used on many projects to break up contaminated concrete by creating localized fractures with repeated blows. They are available from numerous manufacturers.

#### **7.12.4 Concrete Decontamination**

Contaminated concrete surfaces will be decontaminated using conventional means such as vacuuming and wiping with cloths dampened with water or non-hazardous decontamination agents. The following technologies will also be considered and used as appropriate:

#### **Concrete Shaver**

Marcris Industries and Demolition Technologies manufactures manned and remote concrete shavers that remove surface concrete from flat and curved surfaces. The diamond-impregnated shaving blades are ten to 12 inches wide, and each pass of the shaver can remove up to one-quarter inch of concrete at a rate of 128 square feet per hour. The Marcris DTF-25 can shave floors to depths of 0.5 inches. Dust is contained within a HEPA-filtered vacuum system. Manned equipment has been used at the Hanford C Reactor and the remote-controlled equipment has been used at the Rancho Seco Nuclear Plant.

#### **Concrete Spaller**

This hand-held tool is used to decontaminate flat concrete walls and floors by removing concrete pieces ranging from seven to 16 inches in diameter by hydraulically expanding within pre-drilled holes. A shroud collects the pieces of concrete, while a HEPA filter controls the potential release of airborne materials. The spaller removes concrete faster, to a greater depth and at a lower cost per square foot than traditional baseline scabblers and scalers when removing to a depth of one-eighth inch or greater. Pacific Northwest National Laboratory is a manufacturer of spallers.

#### **Centrifugal Shot Blast System**

Concrete Cleaning, Inc. and Pentek manufacture manned and remotely operated centrifugal shot blast scabbling systems that use hardened steel shot at high velocities to remove the outer surface area of concrete. The concrete fragments are captured by an integrated vacuum system. This technology is used in confined space situations and for shallow depths of contamination (less than one inch).



The MOOSE<sup>®</sup>, a remotely operated floor scabbling centrifugal shot blasting system from Pentek, is capable of effectively removing concrete to a depth of 3/16 of an inch and has removed concrete to a depth of one inch with some difficulty (Figure 7-15). The technology was successfully demonstrated at DOE's Fernald facility.

#### Remote Dry-Ice Blasting System

The ROVCO 2 system integrates two demonstrated technologies: a remotely operated vehicle and a dry-ice (CO<sub>2</sub>) blasting system. The vehicle transports and powers the vehicle-mounted subsystems, including the CO<sub>2</sub> XY orthogonal end effector (COYOTEE), cryogenesis dry-ice blasting system, and the vacuum/filtration/containment subsystems. The COYOTEE manipulates a specially designed vacuum containment workhead with the cryogenesis blasting nozzle to cover every point within a rectangular workspace. Since ROVCO 2 utilizes CO<sub>2</sub> gas, it has the potential to eliminate process waste resulting from the blasting material.



Figure 7-15. MOOSE<sup>®</sup>

#### Rotary Drum Planer

The rotary drum planer is widely used to remove concrete in highways and parking lots. This technology consists of a drum with replaceable tungsten-carbide teeth. The planer is attached to a Bobcat loader and cuts a 16-inch swath up to six inches deep, providing that there is no wire or rebar present within the concrete because this metal would break the cutting teeth.

The system can be customized to be dust free by simultaneously drumming the waste with a vacuum shroud. This baseline technology has been used at numerous DOE facilities, including Fernald.

#### Scabblers

This manual or remote technology utilizes a series of tungsten carbide-tipped bits mounted on a hammer head that pulverize the concrete surface via mechanical impacts. The dust and debris removed from contaminated concrete surfaces are then captured by a HEPA-filtered vacuum system. This technology is suitable for removing contaminated concrete from large areas, but is less successful in corners and in concrete seams and cracks. Scabblers have been used on many decommissioning projects, including those at the Argonne National Laboratory and the Idaho National Engineering and Environmental Laboratory.

#### Soft Media Blast Cleaning

Soft Media Blast Cleaning uses a pneumatically propelled soft media to remove surface contaminants. The soft blast media impacts the surface with high energy, absorbing the contaminants and carrying them away from the substrate for easy disposal. This system is used for low levels of surface contamination.

### **Steam Vacuum Cleaning**

The Kelly Decon System uses a pressurized (250 psi) superheated (up to 300°F) water stream to remove contamination from surfaces. Several of the cleaning heads integrate a vacuum hood and return line which captures and controls the steam, water droplets, and dislodged contaminants generated when the water spray impacts on the surface being cleaned. The primary application for the Kelly System has been the surface decontamination of rooms, pools, walls, large components, or similar applications related to large and/or smooth surfaces.

### **Robotic Hammer**

This robotic jackhammering system, manufactured by Bluegrass Bit Co. of Greenville, Alabama, has been used where jack hammering is preferred, but where radiation levels preclude manned operation.

### **Remote-Controlled Brokk Concrete Demolition Systems**

As indicated above, Brokk demolition machines such as the BM 330 model pictured in Figure 7-14, can be used effectively in concrete demolition where radiological conditions make use of remote-controlled equipment preferable.

### **Decontamination Using Liquid Nitrogen Cutting**

As noted previously, a liquid nitrogen cutting and cleaning system such as that offered by Nitrocision® can be used to decontaminate concrete without producing a secondary waste stream.

## **7.12.5 Demolition of Structures**

Structures will be demolished using conventional methods and proven, advanced technologies such as the following:

### **Backhoe Pulverizer**

This machine uses air-powered or hydraulic jaws mounted on a backhoe to crush concrete and separate rebar.

### **Backhoe Ram**

A track-mounted backhoe ram is typically used for demolition of thick concrete or cinder block. It uses a pneumatic or hydraulic moil or chisel point to deliver blows to the area of interest.

### **Bulldozer**

Bulldozers will typically be used to push structure sections down with the blade and pull sections down using wire rope attached to the structure section.

### **Portable Concrete/Asphalt Crusher**

The Eagle Crusher Company, Inc. manufactures a portable concrete/asphalt crusher for size-reducing concrete debris. This equipment is bulky and is setup outside and adjacent to structures. It is best suited for concrete with little or no radioactive contamination.

### **Track-Mounted Shear/Crusher**

This hydraulic equipment (manufactured by Tiger Machine Company) is one of the baseline tools for breaking up concrete surfaces into pieces for disposal. It is effective in razing structures quickly. Criteria for using this equipment are generally the amount of surface area to be broken up and accessibility for large equipment, because the track mounted configuration limits maneuverability.

### **Universal Demolition Processor**

This technology, made by several manufacturers (e.g., Tramac), is essentially three different technologies in one. By exchanging jaw sets, it can be a concrete pulverizer, concrete cracker (including rebar), or a shear capable of cutting thick steel plates. The universal demolition processor is attached to a standard track-mounted carrier. One benefit is that it reduces the amount of equipment on site, due to its multiple capabilities. This equipment has been used at DOE's Fernald facility and at other demolition sites (Figure 7-16)

#### **7.12.6 Excavation and Grading**

DOE will use conventional equipment to remove soil, equipment, and portions of concrete structures, such as tracked excavators. Backhoes and bulldozers will be used as needed. Similar equipment will be used for grading the site.

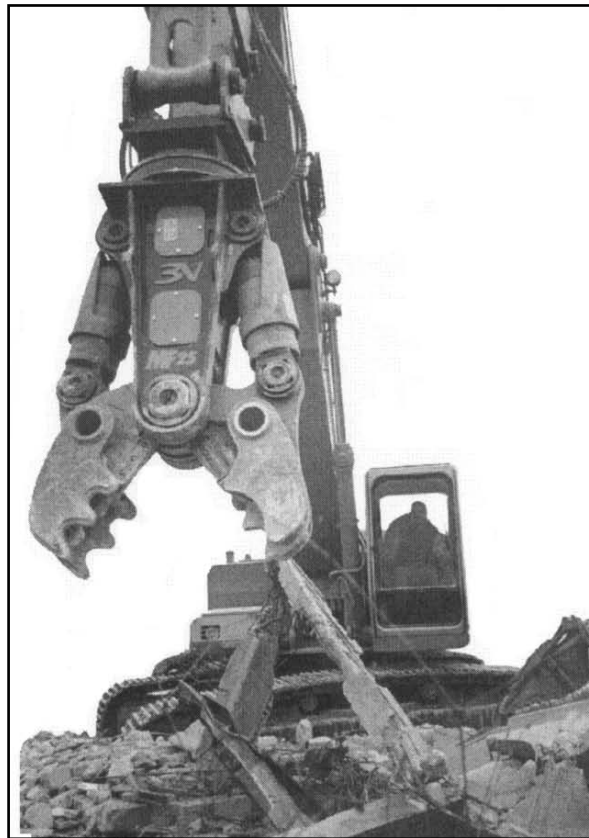

**Figure 7-16. Universal Demolition Processor**

### 7.13 Schedule

Due to the circumstances of the decommissioning – such as the annual federal government funding process and the prerequisite of issuing the Record of Decision for the Decommissioning EIS – it is not practicable for DOE to provide a detailed schedule for the project at this time. Figure 7-17 provides a conceptual schedule for the project, with the basic sequence and order-of-magnitude time frames for major actions.

Work related to removal of the Process Building and the source area of the north plateau groundwater plume is expected to form the project critical path. The decommissioning contractor will develop an optimum sequence after completion of detailed planning. One necessary restraint involves installation of the WMA 1 hydraulic barrier wall before beginning the WMA 2 excavation to reduce infiltration of groundwater into the WMA 2 excavation. The total schedule duration will depend largely on available funding.

The dates on the schedule are contingent upon completion of the NRC review process related to this plan. Before the decommissioning begins, DOE will provide a more detailed schedule to NRC for information. DOE also recognizes that circumstances can change during the decommissioning so that the decommissioning could not be completed as outlined on the schedule. In such a case DOE would revise the schedule and provide the revised schedule to NRC.

WVDP PHASE 1 DECOMMISSIONING PLAN

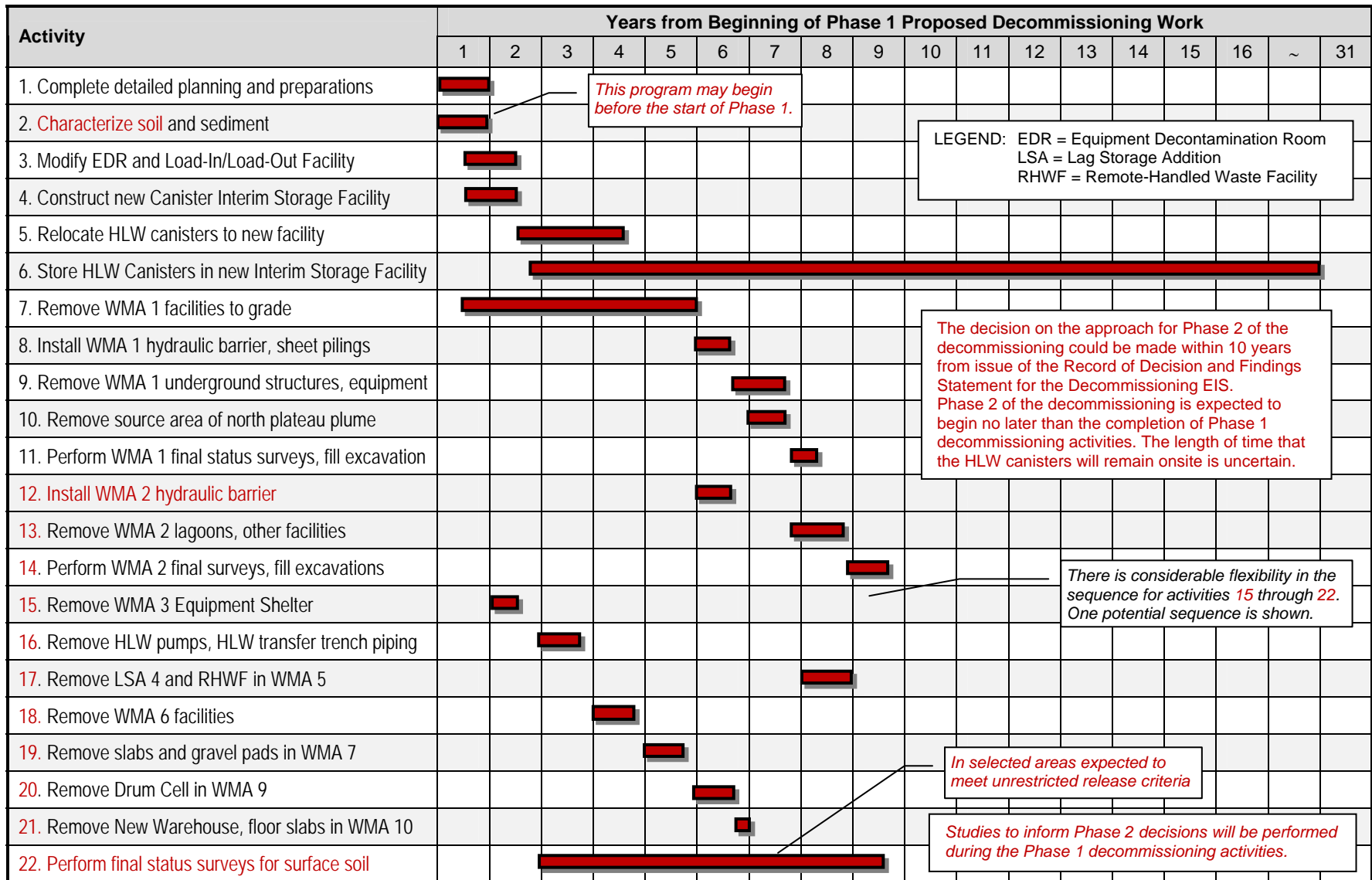

Figure 7-17. Conceptual Schedule of Phase 1 Decommissioning Activities

## WVDP PHASE 1 DECOMMISSIONING PLAN

### 7.13 References

#### Code of Federal Regulations

40 CFR 61, *National Emission Standards for Hazardous Air Pollutants*

#### DOE Manuals

DOE Manual 435.1-1, Revision 1, *Radioactive Waste Management Manual*

#### Other References

EPA, 2007, *Clean Air Act Assessment Package, CAP88-PC, Version 3.0*. U.S. Environmental Protection Agency, Office of Radiation and Indoor Air, Washington, D.C., December 9, 2007.

Hemann and Steiner 1999, *1998 Geoprobe Investigation of the Core Area of the North Plateau Groundwater Plume*, WVDP-346, Revision 0. Hemann, M.R. and R.E. Steiner, III, West Valley Nuclear Services Company, June 11, 1999.

ISCORS 2005, *ISCORS Assessment of Radioactivity in Sewage Sludge: Modeling to Assess Radiation Doses*, Technical Report 2004-03 (NUREG-1783). Interagency Steering Committee on Radiation Standards, Sewage Sludge Subcommittee, Washington, D.C., February 2005.

NRC 1997, *Standard Review Plan for Dry Cask Storage Systems* NUREG-1536, Final Report. U.S. Nuclear Regulatory Commission, Washington, D.C., January 1997.

NRC 2000, *Multi-Agency Radiation Survey and Site Investigation Manual (MARSSIM)*, NUREG-1575, Revision 1. NRC, Washington, DC, August, 2000. (Also EPA 4-2-R-97-016, Revision 1, U.S. Environmental Protection Agency and DOE-EH-0624, Revision 1, DOE)

WVES 2009, *High-Level Waste Canister Storage Evaluation Report*. West Valley Environmental Services, LLC, West Valley, New York, September 2009.

WVNSCO 1994, *Environmental Information Document, Volume IV: Soils Characterization*, WVDP-EIS-008, Revision 0. West Valley Nuclear Services Company, West Valley, New York, September 15, 1994.

WVNSCO 2008, *Safety Analysis Report for Waste Processing and Support Activities*, WVNS-SAR-001, Revision 12. West Valley Nuclear Services Company, West Valley, New York, March 27, 2008.

WVNSCO and Scientech, 2000, *High-Level Waste Canister Shipout from the West Valley Demonstration Project*, Revision 2. West Valley Nuclear Services Company, West Valley, New York and Scientech, Dunedin, Florida, June 30, 2000.