

APPENDIX C
DESCRIPTIONS OF FACILITIES/AREAS,
DECOMMISSIONING ACTIVITIES,
AND NEW CONSTRUCTION

APPENDIX C

DESCRIPTIONS OF FACILITIES/AREAS, DECOMMISSIONING ACTIVITIES, AND NEW CONSTRUCTION

C.1 Introduction

This appendix presents a description of the existing facilities and waste disposal areas associated with the 12 Waste Management Areas (WMAs) at the Western New York Nuclear Service Center (WNYNSC), including the North Plateau Groundwater Plume and Cesium Prong, that are being considered as part of the decommissioning and/or long-term stewardship of the West Valley Demonstration Project (WVDP) and WNYNSC. The descriptions are included in Section C.2. A summary of these descriptions is presented in Chapter 2, Section 2.3, of this environmental impact statement (EIS). The starting point of the EIS is discussed in Chapter 2, Section 2.3.1. Chapter 2 also includes summary information on the status of the Resource Conservation and Recovery Act (RCRA) units on the site.

Unless otherwise referenced, the information in this appendix was obtained from WNYNSC technical reports (WSMS 2009a, 2009b, 2009c, 2009d, 2009e).

Section C.3 of this appendix presents a description of the decommissioning activities for each action alternative evaluated in this EIS. The descriptions of the alternatives and summaries of the decommissioning activities for each alternative are also presented in Chapter 2, Section 2.4, of this EIS.

Section C.4 provides descriptions of the proposed new construction that would be required to support the decommissioning activities at WNYNSC under each action alternative.

C.2 Buildings, Facilities, and Waste Disposal Areas Analyzed in this Environmental Impact Statement

This section provides detailed descriptions of the facilities and areas at WNYNSC that are analyzed in this EIS. The descriptions include historical information, dimensions, status of radioactive and hazardous contamination, as well as radioisotopic and chemical material inventories. A large number of radioactive isotopes have been identified as present at the site. In order to facilitate presentation of data and conduct of the analysis, a dose-based screening analysis was performed to generate a more concise list of radionuclides for detailed analysis. Radionuclides identified for detailed analysis accounted for greater than 99 percent of dose on the screening analysis. Data are presented in this appendix for radionuclides identified for detailed analysis rather than for all radionuclides that may be present on the site.

C.2.1 Waste Management Area 1: Main Plant Process Building and Vitrification Facility Area

WMA 1 encompasses approximately 1.7 hectares (4 acres). Key facilities standing in WMA 1 at the starting point of this EIS will include the Main Plant Process Building, Vitrification Facility, 01-14 Building, Load-In/Load-Out Facility, Utility Room and Utility Room Expansion, Fire Pumphouse and Water Storage Tank, Plant Office Building, Electrical Substations, underground tanks, and Off-Gas Trench. These facilities are shown on **Figure C-1**. Also included in WMA 1 are underground pipelines and the source area of the North Plateau Groundwater Plume. The plume extends through WMAs 1 through 6. The North Plateau Groundwater Plume is described in Section C.2.13.

At the starting point of this EIS, several WMA 1 facilities, including the Fuel Receiving and Storage Ventilation Building; Fuel Receiving and Storage High Integrity Container Storage Area; Radwaste Process (Hittman) Building; Laundry Room; Cold Chemical Facility; Emergency Vehicle Shelter; and Contact Size-Reduction Facility, including the Master Slave Manipulator Repair Shop; will have been removed to grade. The disposition of the remaining concrete foundations and slabs is analyzed in this EIS.

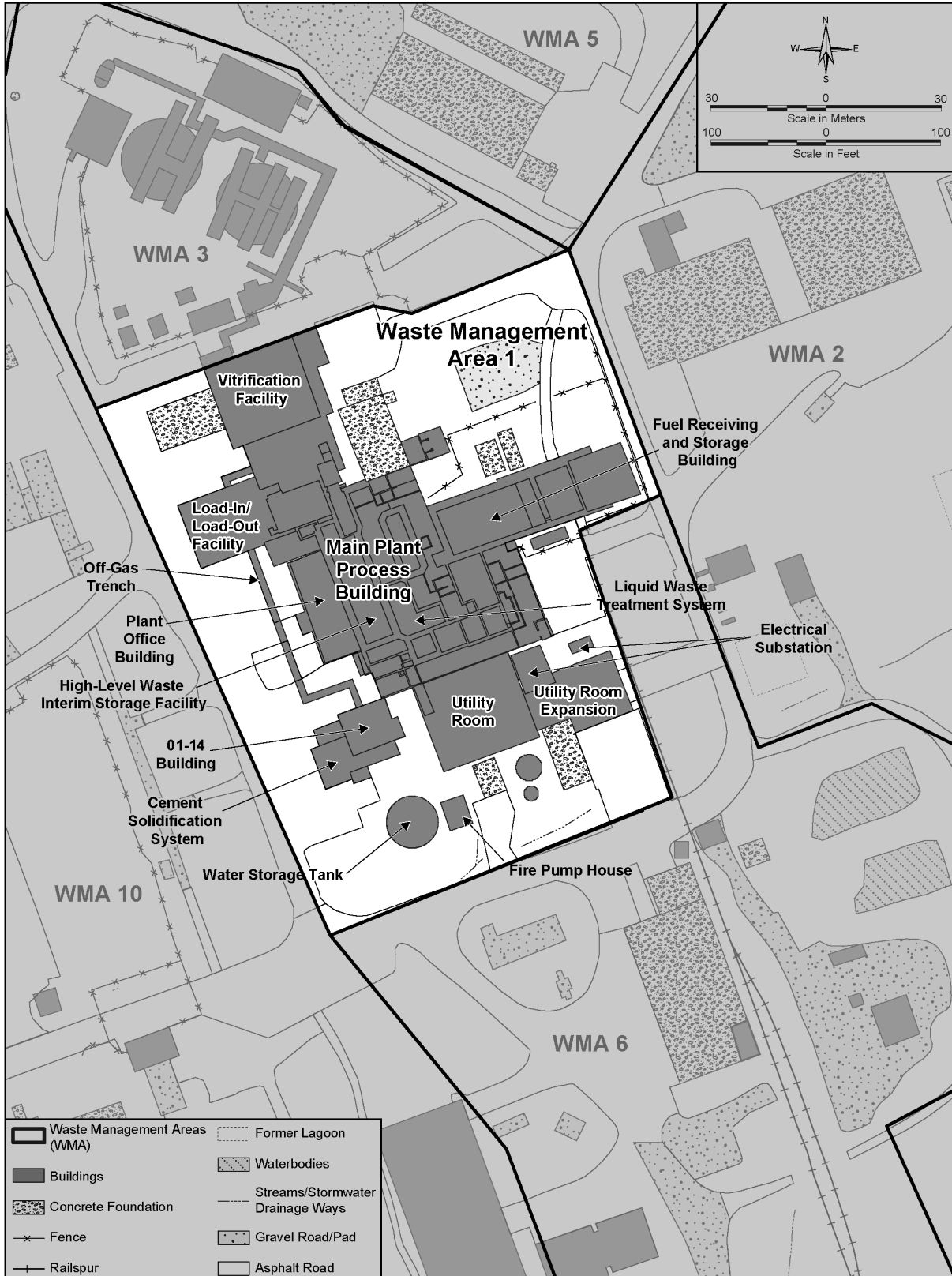

Figure C-1 Waste Management Area 1 – Main Plant Process Building and Vitrification Facility Area

C.2.1.1 Main Plant Process Building

With the exception of the area where the vitrified high-level radioactive waste canisters are stored, most of the Main Plant Process Building will have been decontaminated at the starting point of this EIS to a point where it could be demolished without containment. Areas still operational in support of high-level radioactive waste canister storage will include the Chemical Process Cell Crane Room, Equipment Decontamination Room, Ventilation Supply Room, Ventilation Exhaust Cell, and Head-End Ventilation Building, along with supporting plant utilities. Other equipment that will remain in the Main Plant Process Building is located in the Liquid Waste Cell, Off-Gas Cell, Uranium Product Cell, Ventilation Wash Room, and Off-Gas Blower Room. **Figure C–2** depicts the general arrangement of the building.

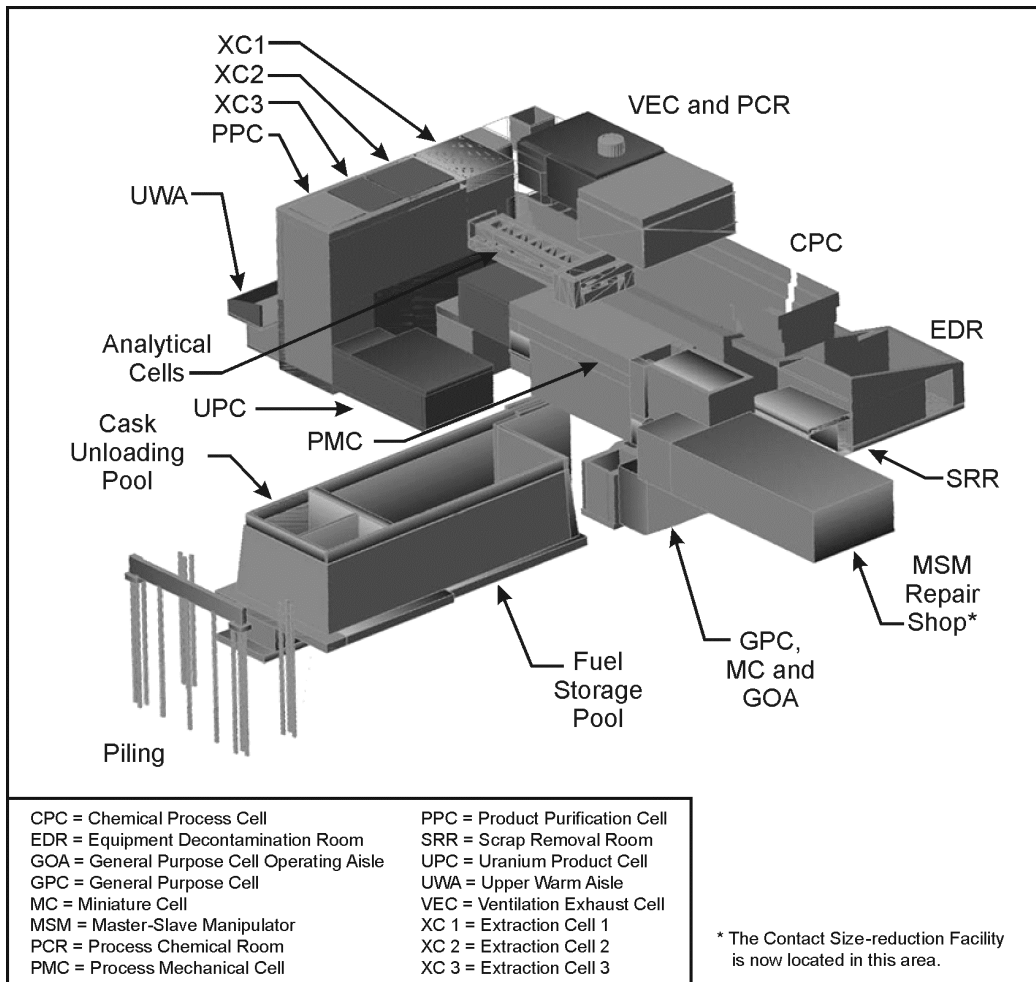

Figure C–2 General Arrangement of the Main Plant Process Building

The Main Plant Process Building was built between 1963 and 1966 and was used by Nuclear Fuel Services, Inc. (NFS) to recover thorium, uranium, and plutonium from irradiated nuclear fuel from 1966 to 1971. This multi-storied building is approximately 40 meters (130 feet) wide and 82 meters (270 feet) long, and it extends approximately 24 meters (79 feet) above the ground surface at its highest point. The major plant structure is founded on driven steel H-piles, which were used to limit differential settlements between cells. The building is composed of a series of cells, aisles, and rooms that are constructed of reinforced concrete and concrete block. The bottoms of the Main Plant Process Building cells are located in the sand and gravel unit. The reinforced concrete walls, floors, and ceilings are 0.3 to 1.8 meters (1 to 6 feet) thick. The reinforced concrete

walls are surrounded by lighter concrete and masonry wall construction, with metal deck flooring. Most of the facility was constructed above-grade. However, a few of the cells extend below the reference ground surface elevation for the Main Plant Process Building. The General Purpose Cell, for example, extends to approximately 9 meters (30 feet) below reference ground elevation. The Cask Unloading Pool and the Fuel Storage Pool, located in the Fuel Receiving and Storage Area on the east side of the building, were used to receive and store spent nuclear fuel sent for reprocessing; they extend approximately 15 and 10 meters (49 and 34 feet) below the reference ground elevation, respectively.

Cells such as the Process Mechanical Cell, the Chemical Process Cell, and the extraction cells were constructed of reinforced high-density concrete 0.9 to 1.5 meters (3 to 5 feet) thick. These thicknesses were needed to provide radiation shielding for the remote mechanical and chemical processing of spent nuclear fuel or management of radioactive liquid waste. The operations performed in the cells were remotely controlled by individuals working in the various aisles of the Main Plant Process Building, which were formed by adjacent walls of the cells. The aisles contained the manipulators and valves needed to support operations in the cells. Rooms not expected to contain radioactivity, such as the Control Room, Ventilation Supply Room, and Extraction Chemical Room, were typically constructed with concrete block and structural steel framing. Such rooms were designed to support the reprocessing operations and typically were not shielded.

Portions of the Main Plant Process Building were modified to support the primary mission of solidifying high-level radioactive waste. Fuel reprocessing equipment was removed from the Chemical Process Cell to allow its use for storage of canisters of vitrified high-level radioactive waste. Currently, 275 vitrified high-level radioactive waste canisters are stored in the Chemical Process Cell. Fuel reprocessing equipment in Extraction Cell 3 and the Product Purification Cell was removed and replaced with equipment used to support the Liquid Waste Treatment System. The Liquid Waste Treatment System was used to treat supernatant and sludge wash solutions from Tank 8D-2, which contained high-level radioactive waste that was also an RCRA-characteristic hazardous waste based on the concentration of several metals.

An estimate of the total amount of residual radioactivity for both the above-grade and below-grade portions of the Main Plant Process Building at the starting point of this EIS is provided in **Table C-1**.

Table C-1 Estimated Radionuclide Inventory Within the Above- and Below-Grade Portions of the Main Plant Process Building

<i>Radionuclide</i>	<i>Estimate (curies)^a</i>	<i>Radionuclide</i>	<i>Estimate (curies)^a</i>	<i>Radionuclide</i>	<i>Estimate (curies)^a</i>
Carbon-14	12.7	Uranium-234	0.196	Plutonium-240	46.6
Strontium-90	1,890	Uranium-235	0.0295	Plutonium-241	1,110
Technetium-99	4.85	Neptunium-237	0.567	Americium-241	272
Iodine-129	0.627	Uranium-238	0.0869	Curium-243	0.276
Cesium-137	2,570	Plutonium-238	202	Curium-244	6.33
Uranium-233	0.410	Plutonium-239	63.4		

^a Decayed to 2011.
Source: WVES 2008a.

The Main Plant Process Building also contains a residual chemical inventory that is regulated under RCRA. This chemical inventory includes lead used for shielding purposes and in lead-based paints, mercury compounds used during fuel reprocessing and in mercury switches, and polychlorinated biphenyls (PCBs) in some electrical equipment. Several areas of the Main Plant Process Building are used for mixed waste treatment and storage.

The amounts of hazardous chemical inventory conservatively estimated to be present within both the above-grade and below-grade portions of the Main Plant Process Building are provided in **Table C–2**. The Main Plant Process Building is a RCRA interim status unit and is subject to RCRA closure.

Table C–2 Estimated Chemical Contamination Within the Above- and Below-Grade Portions of the Main Plant Process Building

<i>Chemical</i>	<i>Contamination (kilograms)</i>	<i>Chemical</i>	<i>Contamination (kilograms)</i>
Antimony	9.9	Lead ^a	187
Arsenic	28	Mercury	0.45
Barium	39	Nickel	254
Beryllium	2.8	Selenium	16
Cadmium	9.4	Silver	14
Chromium	80	Thallium	3.3

^a Excludes lead glass viewing windows.

Note: To convert kilograms to pounds, multiply by 2.2046.

Source: URS 2008a.

Asbestos is generally present around pipe penetrations in the walls of the Main Plant Process Building, in floor tiles, and in ceilings and other places where it was used in insulation. While some of this material may be removed prior to the starting point of the EIS, it is expected that much of it will remain and will have to be removed as part of the scope of this EIS. Asbestos volume is reflected in waste generation estimates for construction and demolition debris for the different alternatives.

C.2.1.2 Vitrification Facility

At the starting point of this EIS, the Vitrification Facility will be in place and will have been decontaminated to allow uncontained demolition.

The Vitrification Facility is a structural steel-framed, sheet metal building that houses the Vitrification Cell, operating aisles, and a control room. The Vitrification Cell is 10.4 meters (34 feet) wide, 19.8 meters (65 feet) long, and 12.8 meters (42 feet) high. At the north end of the Vitrification Cell is the melter pit. The pit is 10.4 meters (34 feet) wide by 7.6 meters (25 feet) long. The bottom of the melter pit is about 4.3 meters (14 feet) below-grade. The Vitrification Cell is lined with a 0.32-centimeter-thick (0.125-inch-thick) stainless steel liner up to 6.7 meters (22 feet) above-grade. High-level radioactive waste transferred from Tank 8D-2 was mixed with glass formers and vitrified into borosilicate glass within the Vitrification Cell. The Vitrification Cell contained the Concentrator Feed Makeup Tank, Melter Feed Hold Tank, Slurry-Fed Ceramic Melter, Turntable, Off-Gas Treatment Equipment, Canister Welding Station, and Canister Decontamination Station. The Vitrification Cell is a mixed waste treatment and storage unit. Vitrification operations were performed remotely by operators in the operating aisles or in the control room. The Vitrification Cell is expected to be radiologically contaminated based on decommissioning activities performed during the removal of the treatment system equipment. It will have been decontaminated, however, and made “demolition-ready” prior to the start of the EIS activities. The operating aisles and control room are not contaminated. The bulk chemical storage tank in the Vitrification Facility would require closure under 6 New York Code of Rules and Regulations (NYCRR) Part 598. At the starting point of this EIS, the Vitrification Cell will be set up for use as a containment building to perform remote-handled size reduction of equipment removed from the Main Plant Process Building.

An estimate of the total amount of residual radioactivity and hazardous chemical inventory present in the Vitrification Facility as contamination at the starting point of the EIS is provided in **Tables C–3** and **C–4**.

Table C-3 Estimated Radionuclide Inventory in the Vitrification Facility

<i>Radionuclide</i>	<i>Estimate (curies) ^a</i>	<i>Radionuclide</i>	<i>Estimate (curies) ^a</i>	<i>Radionuclide</i>	<i>Estimate (curies) ^a</i>
Carbon-14	0.000216	Uranium-234	0.000621	Plutonium-240	0.347
Strontium-90	909	Uranium-235	0.0000171	Plutonium-241	8.66
Technetium-99	0.0376	Neptunium-237	0.00905	Americium-241	14.0
Iodine-129	1.76×10^{-7}	Uranium-238	0.000150	Curium-243	0.0865
Cesium-137	957	Plutonium-238	1.61	Curium-244	1.90
Uranium-233	0.00160	Plutonium-239	0.486		

^a Decayed to 2011.

Source: WVES 2008b.

The amounts of hazardous chemical materials conservatively estimated to be present in the Vitrification Facility at the starting point of this EIS are provided in Table C-4. The Vitrification Facility is a RCRA interim status unit and is subject to RCRA closure.

Table C-4 Estimated Hazardous Chemical Inventory in the Vitrification Facility

<i>Chemical</i>	<i>Contamination (kilograms)</i>	<i>Chemical</i>	<i>Contamination (kilograms)</i>
Antimony	3.5	Lead ^a	66
Arsenic	10	Mercury	0.16
Barium	14	Nickel	90
Beryllium	1.0	Selenium	5.6
Cadmium	3.3	Silver	5
Chromium	28	Thallium	1.2

^a Excludes lead glass viewing windows.

Note: To convert kilograms to pounds, multiply by 2.2046.

Source: URS 2008b.

C.2.1.3 01-14 Building

At the starting point of this EIS, the 01-14 Building will be in place and will have been decontaminated to allow uncontained demolition.

The 01-14 Building is a four-story, 18-meter-tall (60-foot-tall) concrete and steel-framed building located next to the southwest corner of the Main Plant Process Building. This building was built by NFS in 1971 to house an off-gas system and acid recovery system, which were to be located in the off-gas treatment cell and acid fractionator cell portions of the building. However, the building was never used to support NFS operations. The 01-14 Building currently houses the Vitrification Off-Gas System and the Cement Solidification System. The Vitrification Off-Gas System, located in the northeast section of the building, was used to treat off-gases generated from the melter in the WVDP Vitrification Facility. The Cement Solidification System was used to stabilize mixed low-level radioactive waste generated from the low-level waste treatment system in a cement matrix and to package this mixture in 270-liter (71-gallon) square drums that were stored in the Radwaste Treatment System Drum Cell (Drum Cell).

An estimate of the total amount of residual radioactivity present in the 01-14 Building at the starting point of this EIS is provided in **Table C-5**.

The 01-14 Building is a RCRA interim status unit and is subject to RCRA closure.

Table C–5 Estimated Radionuclide Inventory in the 01-14 Building

<i>Radionuclide</i>	<i>Estimate (curies)^a</i>	<i>Radionuclide</i>	<i>Estimate (curies)^a</i>	<i>Radionuclide</i>	<i>Estimate (curies)^a</i>
Carbon-14	0.0000410	Uranium-234	0.00561	Plutonium-240	0.0642
Strontium-90	165	Uranium-235	0.00540	Plutonium-241	1.50
Technetium-99	0.170	Neptunium-237	0.00381	Americium-241	2.69
Iodine-129	3.20×10^{-8}	Uranium-238	0.00520	Curium-243	0.0156
Cesium-137	174	Plutonium-238	0.296	Curium-244	0.334
Uranium-233	0.0120	Plutonium-239	0.0910		

^a Decayed to 2011.

Source: WVES 2008a.

C.2.1.4 Load-In/Load-Out Facility

The Load-In/Load-Out Facility is located adjacent to the west wall of the Equipment Decontamination Room of the Main Plant Process Building. The facility is a structural steel and steel-sided building that is 24.2 meters (80 feet) long, 16.9 meters (55 feet) wide, and 16.5 meters (54 feet) tall. The floor is poured concrete and the roof is metal sheeting with insulation. This facility was used to move empty canisters and equipment into and out of the Vitrification Cell. The Load-In/Load-Out Facility has a truck bay and a 13.7-metric ton (15-ton) overhead crane that is used to move canisters and equipment. The facility is not radioactively contaminated.

C.2.1.5 Utility Room and Utility Room Expansion

The Utility Room is a concrete block and steel-framed building located on the south end of the Main Plant Process Building. The Utility Room consists of two adjoining buildings that were built at different times, the original Utility Room and the Utility Room Expansion. The original Utility Room, which was built during construction of the Main Plant Process Building, makes up the western portion of the Utility Room and is 24 meters (80 feet) wide, 27 meters (88 feet) long, and 6 meters (20 feet) high. The Utility Room contains equipment that supplies steam, compressed air, and various types of water to the Main Plant Process Building and the Waste Tank Farm. Based on process history and the results of routine radiological surveys, the Utility Room is not expected to have significant radiological contamination. However, the pipe trench in the original Utility Room is reported to be radioactively contaminated and may have chemical contamination. Chemicals, such as mercury, acids, oils, biocides, and water treatment chemicals, have been used and stored in the Utility Room; some of these were spilled and subsequently cleaned up. The Utility Room also contains equipment contaminated with asbestos and PCBs.

An aboveground 37,850-liter (10,000-gallon) No. 2 fuel oil tank is located outside the Utility Room. The aboveground fuel oil tank would require closure under 6 NYCRR Part 613 regulations. Asbestos-containing material associated with the fuel oil tank would be managed as asbestos-containing waste in accordance with New York State and Toxic Substances Control Act requirements.

The Utility Room Expansion was built in the early 1990s immediately adjacent and connected to the original Utility Room. The Utility Room Expansion is approximately 26 meters (85 feet) long, 17 meters (56 feet) wide, and 7.6 meters (25 feet) high. Because this building is new, and because radioactive waste processing operations were not performed in it, the Utility Room Expansion is not expected to be contaminated. Routine radiological surveys have not detected any radiological contamination in this area.

C.2.1.6 Fire Pumphouse and Water Storage Tank

The Fire Pumphouse was constructed when the Main Plant Process Building was built in 1963. The footprint of the facility is 6 meters (20 feet) wide by 7.3 meters (24 feet) long. It is 2.4 meters (8 feet) high along one length and 3 meters (10 feet) high at the peak. It is supported on a concrete foundation wall that is 20 centimeters (8 inches) thick and extends 1.2 meters (4 feet) below-grade. The flooring is a concrete slab that is 10 centimeters (4 inches) thick. Construction materials include a steel-beam frame, metal siding with insulation, and a light metal roof. The Fire Pumphouse contains two pumps on concrete foundations. One is driven by an electric motor with a diesel engine backup, and the other is driven by a diesel engine. A 1,098-liter (290-gallon) double-wall, carbon steel diesel fuel day tank with No. 2 fuel oil is also located in the Fire Pumphouse. The fuel oil tank would require closure under 6 NYCRR Part 613. A light metal storage shed that is about 1.5 meters (5 feet) long and 0.9 meters (3 feet) wide rests on a concrete slab that is 2 meters (7 feet) long, 1.8 meters (6 feet) wide, and 20 centimeters (8 inches) thick. The shed is used to store fire hoses and fire extinguishers.

A 1.8 million-liter (477,000-gallon) Water Storage Tank stores water for firefighting purposes. The Fire Pumphouse and the Water Storage Tank are not expected to be radioactively contaminated based on process knowledge and routine radiological surveys.

C.2.1.7 Plant Office Building

The Plant Office Building is a three-story concrete block and steel-framed structure located adjacent to the west side of the Main Plant Process Building. The Plant Office Building is approximately 12 meters (40 feet) wide, 29 meters (95 feet) long, and 13.4 meters (44 feet) high; it contains offices and men's and women's locker rooms. The Plant Office Building is designated as an unrestricted occupancy area. However, an undetermined amount of radiological contamination is present beneath the floor in the men's shower room. This contamination originated during NFS operations from releases of radioactive acid from the Acid Recovery System from 1968 to 1970. Those releases and other leaks and spills are described in Chapter 3, Section 3.11.5. This system was housed in the southwest corner of the Main Plant Process Building. The leaking acid flowed down the walls of the off-gas cell and the adjacent southwest stairwell into the sand and gravel unit underlying the Main Plant Process Building.

C.2.1.8 Electrical Substation

The Electrical Substation is located adjacent to the southeast corner of the Main Plant Process Building. A 34.5-kilovolt/480-volt transformer rests on a concrete foundation behind a steel-framed structure. The transformer contains 2,220 liters (586 gallons) of oil containing PCBs at 292 parts per million. Disposition of PCBs would be in accordance with 40 *Code of Federal Regulations* (CFR) Part 761 and 6 NYCRR Parts 370 to 376. No radiologically contaminated areas have been identified at the Electrical Substation (DOE 1996a).

C.2.1.9 Underground Tanks

Tanks 35104, 7D-13, and 15D-6 are located underground in the vicinity of the Main Plant Process Building.

Tank 35104 is a 22,300-liter (5,900-gallon) stainless steel tank located in an underground concrete vault connected to the west end of the General Purpose Cell Crane Room. The tank serves as a collection and hold tank for liquid from drains in the Equipment Decontamination Room, Chemical Crane Room, and other contaminated areas. The tank also received liquid waste from the Supernatant Treatment System (STS). It contains mixed radioactive liquids (containing both radiological and RCRA components).

Tank 7D-13 is a 7,600-liter (2,000-gallon) stainless steel horizontal underground tank located southwest of the Main Plant Process Building. The bottom of the tank lies 4.3 meters (14 feet) belowgrade. The tank was used as a holding tank for liquid waste from the Laundry Room and the laboratories prior to transfer to the Low-Level Waste Treatment Facility. Due to an accumulation of solids in the bottom of the tank, it was taken out of service in 1988. Part of the contents, consisting of water and concrete fines characterized as transuranic waste, was removed. An inspection in 2000 disclosed that an estimated 568 to 1,140 liters (150 to 300 gallons) of cement solids remained at the bottom of the tank.

Tank 15D-6 is a 5,700-liter (1,500-gallon) vertical underground stainless steel tank located in an earthen and gravel vault outside the east wall of the Contact Size Reduction Facility. It is approximately 1.8 meters (6 feet) in diameter by 2.4 meters (8 feet) high, with the bottom of the tank lying 4.7 meters (16 feet) belowgrade. The tank was the waste catch tank for the Master Slave Manipulator Repair Shop and Contact Size Reduction Facility. The tank level recorded in April 2004 indicated that it contained approximately 860 liters (227 gallons) of radioactive contents.

C.2.1.10 Off-Gas Trench

The Off-Gas Trench is an underground shielded concrete transfer trench located on the west side of the Main Plant Process Building between the Vitrification Facility and the 01-14 Building. The final treatment of the off-gas that was generated by the vitrification cell melter and vessel vent system was performed in the 01-14 Building because it contained off-gas equipment and allowed access to the Main Plant Process Building stack. The off-gas generated by vitrification was scrubbed and passed through high-efficiency particulate air (HEPA) filters. The filtered off-gas stream was transferred to the 01-14 Building for further processing via an insulated 25-centimeter-diameter (10-inch-diameter) duct in the Off-Gas Trench. The duct has radioactive contamination. The Off-Gas Trench is not expected to be contaminated.

C.2.1.11 Underground Lines

At the starting point of this EIS, the underground pipelines within WMA 1 will still be in place. During construction of WMA 1 facilities, approximately 125 underground pipelines designed to convey radioactive liquids were installed in the vicinity of the Main Plant Process Building. These lines are buried at depths ranging from 1.4 to 3.7 meters (4.5 to 12 feet) belowgrade.

C.2.2 Waste Management Area 2: Low-Level Waste Treatment Facility Area

WMA 2, the Low-Level Waste Treatment Facility Area, is shown on **Figure C-3**. WMA 2 encompasses approximately 5.5 hectares (14 acres). It was used by NFS and WVDP to treat low-level radioactive wastewater generated on site. Facilities and areas analyzed in this EIS include the Low-Level Waste Treatment Facility; inactive filled Lagoon 1; active Lagoons 2, 3, 4, and 5; Neutralization Pit; New and Old Interceptors; Solvent Dike; Maintenance Shop Leach Field; and Fire Brigade Training Area. Included in WMA 2 is a portion of the North Plateau Groundwater Plume, which also extends through WMAs 1, 3, 4, 5, and 6.

At the starting point of this EIS, the 02 Building, Test and Storage Building, Vitrification Test Facility, Vitrification Test Facility Waste Storage Area, Maintenance Shop, Maintenance Storage Area, Vehicle Maintenance Shop, and Industrial Waste Storage Area will have been removed to grade. The disposition of the concrete foundations and slabs is analyzed in this EIS.

The Solvent Dike, Neutralization Pit, interceptors, and lagoons are radiologically contaminated and are known to contain hazardous chemical constituents originating from the management of wastewater containing chemical contaminants. Radiological inventories are shown in the following subsections. There is no data to describe or quantify any hazardous chemical constituents that are present (WVNSCO 1997).

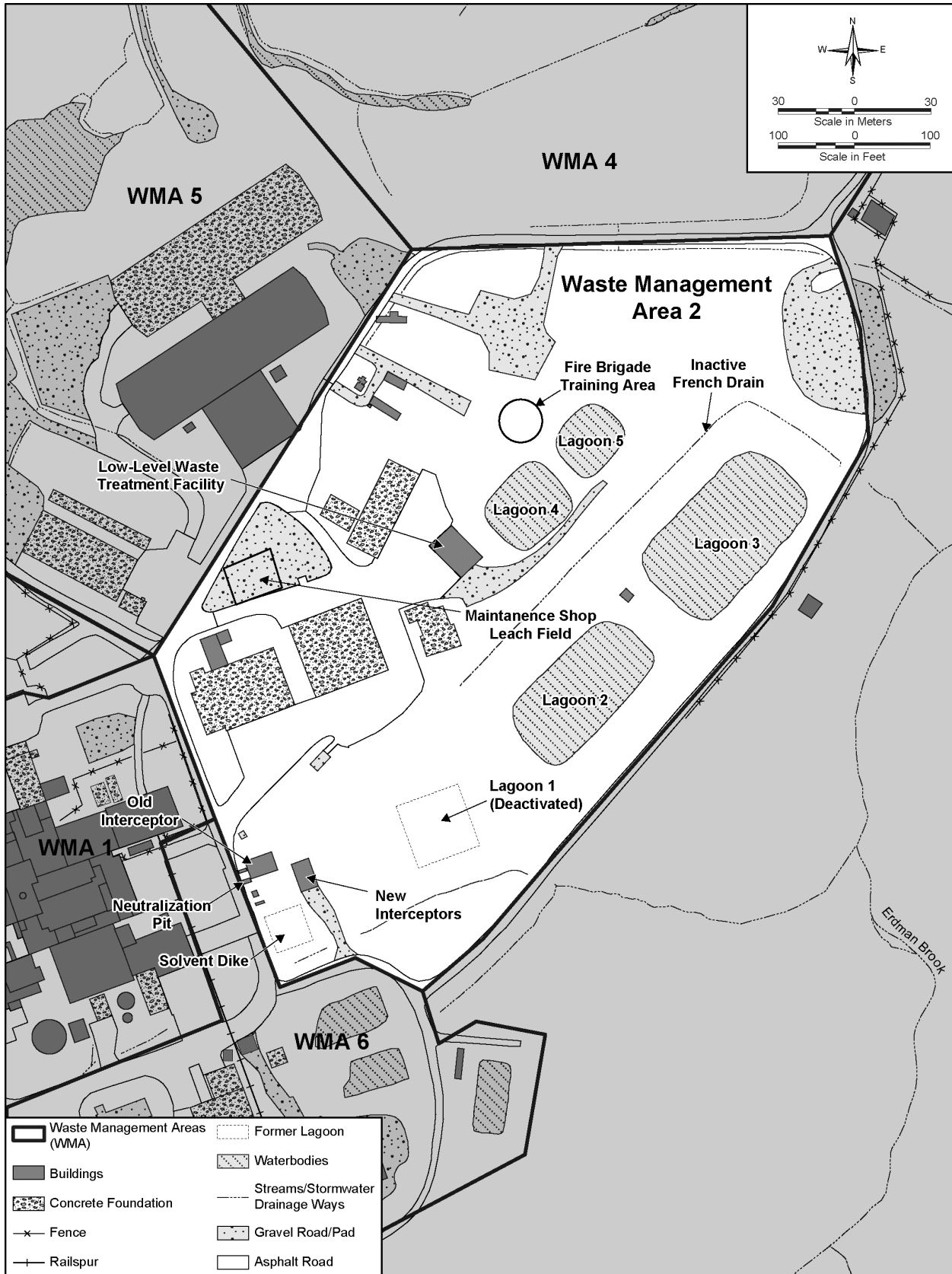

Figure C-3 Waste Management Area 2 – Low-Level Waste Treatment Facility Area

C.2.2.1 Low-Level Waste Treatment Facility

The Low-Level Waste Treatment Facility is located southwest of Lagoon 4; it is a pre-engineered, single-story, metal-sided building on a concrete foundation measuring 12 meters (40 feet) by 18 meters (60 feet). The 6- by 6-meter (20- by 20-foot) Packaging Room, which is typically used for resin handling, includes a 3,400-liter (900-gallon) sump and is ventilated by HEPA filters. The Low-Level Waste Treatment Facility houses two skid-mounted process equipment modules. One skid processes wastewater from the Main Plant Process Building, the Waste Tank Farm Area (WMA 3), and the NRC [U.S. Nuclear Regulatory Commission]-Licensed Disposal Area (NDA) and its associated facilities (WMA 7). The second skid is used to process radiologically contaminated groundwater from the North Plateau Groundwater Plume. The equipment in the facility is radiologically contaminated, including that in the Packaging Room. The Low-Level Waste Treatment Facility is identified as a Solid Waste Management Unit (SWMU) and is subject to Clean Water Act corrective action and closure requirements.

C.2.2.2 Lagoon 1

Lagoon 1 was an unlined pit excavated into the sand and gravel unit. It was fed directly from the Old and New Interceptors and had a storage capacity of approximately 1,140,000 liters (300,000 gallons). This lagoon was removed from service in 1984 after a determination was made that it was the source of tritium contamination to nearby groundwater. The liquid and a majority of the contaminated sediment were transferred to Lagoon 2. Lagoon 1 was filled with approximately 1,300 cubic meters (1,700 cubic yards) of radiologically contaminated debris from the Old Hardstand, including asphalt, trees, stumps, roots and weeds. It was capped with clay, covered with topsoil, and revegetated. Groundwater immediately downgradient of the Lagoon 1 area is routinely monitored with wells as part of a Sitewide Environmental Monitoring Program.

At the starting point of this EIS, Lagoon 1 is estimated to contain approximately 550 curies of cesium-137 and significant quantities of transuranic radionuclides, predominantly in the sediment. **Table C-6** presents the radionuclide inventory that is estimated to be present in Lagoon 1 at the starting point. Lagoon 1 is identified as a SWMU subject to corrective action requirements pursuant to the RCRA 3008(h) Consent Order. A Corrective Measures Study is being prepared.

Table C-6 Estimated Radionuclide Inventory in Lagoon 1

<i>Radionuclide</i>	<i>Estimate^a (curies)</i>	<i>Radionuclide</i>	<i>Estimate^a (curies)</i>
Carbon-14	0.0529	Uranium-238	0.025
Strontium-90	18.8	Neptunium-237	0.00315
Technetium-99	0.204	Plutonium-238	6.55
Iodine-129	0.0285	Plutonium-239	3.78
Cesium-137	547	Plutonium-241	156
Uranium-233	0.225	Americium-241	10.9
Uranium-234	0.0118	Curium-244	0.216
Uranium-235	0.0027		

^a Decayed to 2011.
Source: WVNS 1995.

C.2.2.3 Lagoons 2, 3, 4, and 5

Lagoon 2 is an unlined pit that was excavated through 3 to 4.6 meters (10 to 15 feet) of sand and gravel into the top 0.6 to 2.1 meters (2 to 6.9 feet) of the Lavery till. Water levels are maintained 0.9 meters (3 feet) below the sand and gravel/till interface. It has a storage capacity of 9.1 million liters (2.4 million gallons). It is used as a storage basin for wastewater discharged from the New Interceptors before its contents are transferred to the Low-Level Waste Treatment Facility for treatment. Prior to installation of the Low-Level Waste Treatment Facility, wastewater was routed through Lagoons 1, 2, and 3, in series, before discharge to Erdman Brook.

Lagoon 2 became the initial receiving lagoon for the wastewater treatment system after closure of Lagoon 1. Radioactive contamination is known to be present in Lagoon 2 sediment. A French drain is located on the northwest sides of Lagoons 2 and 3 and the northeast side of Lagoon 3. The drain was installed to prevent groundwater in the sand and gravel unit from flowing into Lagoons 2 and 3. The French drain was used to collect groundwater and discharge it to Erdman Brook through a permitted outfall. The French drain was closed in May 2001 (WVES and URS 2008) due to elevated levels of lead and with a subsequent lack of discharges to Erdman Brook. RCRA hazardous chemical constituents have been identified in shoreline sediments (WVNSCO 1997).

Lagoon 3 is an unlined pit with a storage capacity of 12.5 million liters (3.3 million gallons) that was excavated through 3 to 4.6 meters (9.8 to 15 feet) of sand and gravel into the top 2.7 to 4.3 meters (8.9 to 14 feet) of the Lavery till. Water levels were maintained 1.5 to 2.4 meters (4.9 to 7.9 feet) below the sand and gravel/till interface. After installation of the 02 Building, Lagoon 3 was disconnected from Lagoon 2 and emptied, and its sediment was removed and buried in the NDA in WMA 7. Currently, Lagoon 3 only receives treated water from Lagoons 4 and 5. Treated wastewater in Lagoon 3 is periodically discharged to Erdman Brook in batches through a State Pollutant Discharge Elimination System (SPDES)-permitted outfall. Process knowledge and available data indicate that Lagoon 3 contains much less radioactivity than Lagoon 2 (WVNS 1995). Sampling results do not indicate the presence of RCRA hazardous chemical constituents (WVNSCO 1997).

The upgradient part of Lagoon 4 was excavated into the sand and gravel, and the excavated material was used to create berms in the downgradient end. The lagoon was lined with an ethylene propylene diamine membrane. In the late 1990s, the liner was replaced with concrete grout and a geomembrane liner with a capacity of 772,000 liters (204,000 gallons). The liner was added after the first few years of operation as the lagoon was considered a potential source of tritium contamination. It receives treated water from the Low-Level Waste Treatment Facility and discharges it to Lagoon 3. Low levels of radioactive contamination are expected both above and below the lagoon liner. Sampling results do not indicate the presence of RCRA hazardous chemical constituents (WVNSCO 1997).

The upgradient part of Lagoon 5 was also excavated into the sand and gravel, and the excavated material was used to create berms in the downgradient end. The lagoon was lined with an ethylene propylene diamine membrane. In the late 1990s, the liner was replaced with concrete grout and a geomembrane liner with a capacity of 628,000 liters (166,000 gallons). The liner was added after the first few years of operation as the lagoon was considered a potential source of tritium contamination. It receives treated water from the Low-Level Waste Treatment Facility and discharges it to Lagoon 3. Low levels of radioactive contamination are expected both above and below the lagoon liner. Sampling results do not indicate the presence of RCRA hazardous chemical constituents (WVNSCO 1997).

Lagoons 2 through 5 are identified as SWMUs and are subject to Clean Water Act corrective action and closure requirements.

The residual radionuclide inventory in Lagoon 2 is estimated to be approximately two orders of magnitude lower than that in Lagoon 1, and the inventories in Lagoons 3 through 5 are expected to be one or more orders of magnitude lower than the Lagoon 2 inventory. The residual radioactivity in Lagoons 2 and 3 is expected to be located in the top several inches of the bottom sediment; in Lagoons 4 and 5 it is expected to be in sediment on and under the lagoon liners. The projected radionuclide inventory of Lagoon 2 at the starting point of this EIS is presented in **Table C-7**. The inventory is not presented for Lagoons 3 through 5 because the inventories would be three or more orders of magnitude lower than the Lagoon 1 inventory (DOE 1996a, WVNS 1995).

Table C–7 Estimated Radionuclide Inventory in Lagoon 2

<i>Radionuclide</i>	<i>Estimate^a (curies)</i>	<i>Radionuclide</i>	<i>Estimate^a (curies)</i>
Tritium	Not reported	Uranium-235	0.00599
Carbon-14	0.000548	Neptunium-237	0.0000326
Strontium-90	4.48	Uranium-238	0.000719
Technetium-99	0.00211	Plutonium-238	0.0464
Iodine-129	4.41 × 10 ⁻⁶	Plutonium-239	0.0425
Cesium-137	4.76	Plutonium-241	1.61
Uranium-233	0.00233	Americium-241	0.124
Uranium-234	0.00185	Curium-244	0.00224

^a Decayed to 2011.

Source: WVNS 1995, DOE 1996a.

C.2.2.4 Neutralization Pit and Interceptors

The Neutralization Pit is a 2.7- by 2.1- by 1.7-meter (9- by 7- by 5.5-foot) below-grade tank constructed with 15.2-centimeter-thick (6-inch-thick) concrete walls and floor. The tank initially had an acid-resistant coating that failed and was replaced with a stainless steel liner. The pit is radiologically contaminated and may contain chemical constituents derived from the management of low-level radioactive wastewater. The Neutralization Pit receives liquid low-level radioactive waste from floor drains in the Main Plant Process Building. Sodium hydroxide or potassium hydroxide is added to the wastewater through floor drains in the Utility Room to maintain a pH of greater than 10 for insect larvae control. The liquid is subsequently transferred to Lagoon 2.

The Old Interceptor is a 12- by 7.6- by 3.5-meter (40- by 25- by 11.5-foot) unlined concrete liquid waste storage tank located below-grade. The floor was initially 30.5 centimeters (12 inches) thick, but in 1967 an additional 30.5 centimeters (12 inches) of concrete were added to provide radiation shielding after some wastewater with higher than normal levels of contamination was inadvertently sent to it. The walls are 30.5 centimeters (12 inches) thick. The roof is made of steel. The Old Interceptor received low-level liquid waste generated at the Main Plant Process Building from the time of initial operation until the New Interceptors were constructed. The Old Interceptor is currently used for storing radiologically contaminated liquids that exceed the effluent standard of 0.005 microcuries per milliliter gross beta activity. It is radioactively contaminated. After verification of acceptable radiological contamination concentrations, the contents are transferred by steam jet to the New Interceptors.

The New Interceptors were constructed and began operations between July 1, 1967, and September 30, 1967. The interceptors are twin (north and south) below-grade concrete storage tanks with dimensions of 6.7 meters by 6.1 meters by 3.5 meters (22 by 20 by 11.5 feet). The walls and floor are 35.6 centimeters (14 inches) thick and are lined with 14-gauge Type 304L stainless steel. The New Interceptors are open-topped but have a sheltering steel roof several feet above the open tops. The New Interceptors replaced the Old Interceptor and are used as liquid sample points before transfer of the liquid to Lagoon 2. The New Interceptors are radiologically contaminated.

Relatively small amounts of residual radioactivity (less than 0.01 curies) are expected to be present in the Neutralization Pit and the interceptors, except for the Old Interceptor. Fixed contamination is expected in the concrete walls and floor and on the stainless steel liner in the Neutralization Pit. Most of the inventory in the Old Interceptor is encapsulated by concrete poured into the lower portion of the interceptor. There is no estimate for the encapsulated inventory. Most of the contamination in the New Interceptors is expected to be on the stainless steel liner. Strontium-90 and cesium-137 dominate the residual radioactivity in the Neutralization Pit and interceptors. The Neutralization Pit and interceptors are identified as a SWMU subject to corrective action requirements pursuant to the RCRA 3008(h) Consent Order. A Corrective Measures Study is being prepared.

C.2.2.5 Solvent Dike

The Solvent Dike is located about 90 meters (300 feet) east of the Main Plant Process Building. It was a 9- by 9-meter (30- by 30-foot) unlined basin, excavated in the sand and gravel layer. It received rainwater runoff from the Solvent Storage Terrace, which formerly housed an acid storage tank and three storage tanks containing a mixture of used n-dodecane and tributyl phosphate. Because of elevated radiation fields measured during a 1986 field gamma radiation survey, the solvent dike was excavated. Soil sampling and analysis detected elevated radionuclide concentrations, including strontium-90, cesium-137, americium-241, and uranium and plutonium isotopes. Contaminated soil, which also contained n-dodecane and tributyl phosphate, was removed from the dike and placed in appropriate drums with sorbent material and moved to Lag Storage. The excavation was backfilled with clean topsoil, graded, and seeded; however, the Solvent Dike still contains radiologically contaminated soil. The Solvent Dike is identified as a SWMU; however, it has been determined that no further action is required.

C.2.2.6 Maintenance Shop Leach Field

The Maintenance Shop Leach Field occupies an area of 140 square meters (1,500 square feet) and consists of three septic tanks, a distribution box, a tile drain field, and associated piping. The leach field served the Maintenance Shop and the Test and Storage Building before these buildings were connected to the sanitary sewer system in 1988. RCRA hazardous constituents were detected in the sediment of one septic tank, but none of the concentrations exceeds RCRA hazardous waste criteria or action levels prescribed by New York State Department of Environmental Conservation (NYSDEC). All three tanks are out of service and have been filled with sand. The Maintenance Shop Leach Field is identified as a SWMU; however, it has been determined that no further action is required.

C.2.2.7 Fire Brigade Training Area

The Fire Brigade Training Area is a 6.1- by 6.1-meter (20- by 20-foot) area north of Lagoon 4 that was used two to four times a year between 1982 and 1993 for several types of firefighting training exercises. Piles of wood coated with kerosene or diesel fuel were ignited and then extinguished with water and/or foam. Other exercises involved diesel fuel and water mixtures placed in a shallow metal pan that were ignited and extinguished using a steady stream of water and/or foam. These training exercises were conducted pursuant to the Restricted Burning Permits issued for the training area. Wastes managed in the Fire Brigade Training Area would have included wood ash, residual kerosene or diesel fuel, and water and/or foam used to extinguish the fires. The training area is identified as a SWMU; however, it has been determined that no further action is required.

C.2.2.8 Underground Pipelines

At the starting point of this EIS, the underground pipelines within WMA 2 will still be in place. Of these, 47 wastewater pipelines are known to be radioactively contaminated. Other pipes contain insignificant amounts of residual radioactivity.

C.2.3 Waste Management Area 3: Waste Tank Farm Area

WMA 3, the Waste Tank Farm Area, shown on **Figure C-4**, encompasses approximately 0.8 hectare (2 acres). It includes the waste storage tanks (8D-1, 8D-2, 8D-3, and 8D-4) and associated vaults, High-Level Waste Transfer Trench, Permanent Ventilation System Building, STS, STS Support Building, Equipment Shelter and Condensers, Con-Ed Building, and underground pipelines. A Tank and Vault Drying System will be installed to dry the remaining liquid heels in the tanks prior to the starting point of this EIS. Included in WMA 3 is a portion of the North Plateau Groundwater Plume, which also extends through WMAs 1, 2, 4, 5, and 6.

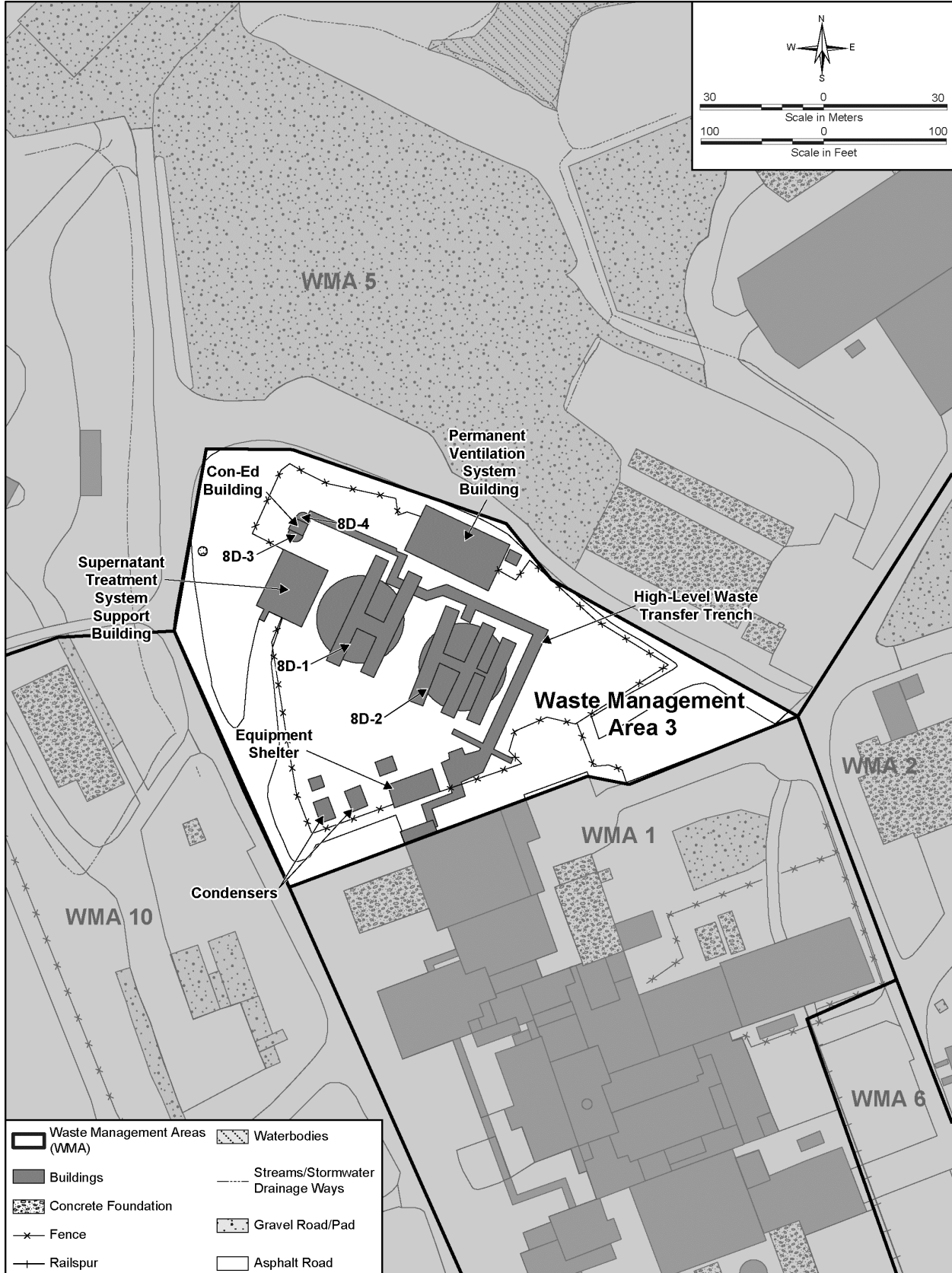

Figure C-4 Waste Management Area 3 – Waste Tank Farm Area

C.2.3.1 Waste Storage Tanks and Vaults

Waste Storage Tanks 8D-1, 8D-2, 8D-3, and 8D-4 were built to store liquid high-level radioactive waste generated during spent nuclear fuel reprocessing operations. Tanks 8D-2 and 8D-4 were used to store plutonium-uranium extraction (PUREX) and thorium extraction (THOREX) wastes, respectively, from reprocessing operations. Tanks 8D-1 and 8D-3 were maintained as companion spare tanks. These tanks were subsequently modified to support treatment of high-level radioactive waste during implementation of WVDP. Modifications included constructing a fabricated steel truss system over the tanks to carry the weight of sludge mobilization and transfer pumps and installing treatment equipment in Tank 8D-1. The Waste Storage Tanks are RCRA interim status units and are subject to RCRA closure.

The estimated residual radioactivity and hazardous chemical inventories in the tanks at the starting point of this EIS are shown in **Table C-8** and **C-9**. A large number of radioactive isotopes have been identified as present at the site. In order to facilitate presentation of data and conduct of the analysis, a dose-based screening analysis was performed to generate a more concise list of radionuclides for detailed analysis. Radionuclides identified for detailed analysis accounted for greater than 99 percent of dose on the screening analysis. Data are presented in this appendix for radionuclides identified for detailed analysis rather than for all radionuclides that may be present on the site.

Table C-8 Radionuclide Inventory in the Waste Tank Farm – Conservative Case ^a

<i>Radionuclide</i> ^b	<i>Tank 8D-1</i> <i>(curies)</i>	<i>Tank 8D-2</i> <i>(curies)</i>	<i>Tank 8D-3</i> <i>(curies)</i>	<i>Tank 8D-4</i> <i>(curies)</i>	<i>Total</i> <i>(curies)</i>
Carbon-14	0.020	0.00546	0.0000147	0.00999	0.0355
Strontium-90 ^c	1,950	29,000	0.691	4,440	35,400
Technetium-99	5.40	5.85	0.0156	0.240	11.5
Iodine-129	0.0068	0.00768	0.0000196	0.0032	0.0177
Cesium-137 ^c	213,000	85,900	0.176	1,690	301,000
Uranium-233	0.260	0.0873	0.00214	0.044	0.393
Uranium-234	0.100	0.0361	0.000770	0.00328	0.140
Uranium-235	0.00340	0.00134	0.0000211	0.000140	0.0049
Uranium-238	0.0310	0.00815	0.000206	0.0000560	0.0394
Neptunium-237	0.0230	0.517	0.000258	0.0120	0.552
Plutonium-238	5.30	139	0.0100	19.2	164
Plutonium-239	1.50	36.8	0.00267	0.630	38.9
Plutonium-240	1.10	26.8	0.00192	0.310	28.2
Plutonium-241	31.4	535	0.0709	11.8	578
Americium-241	0.793	387	0.0197	2.70	391

^a In the first of the two references cited below (the primary reference), three estimates are provided for the curie content as follows: Best Estimate Case (typically presents the lowest values); Worst Estimate Case (highest values); and Conservative Case (values somewhere in between). The latter case was assumed. Inventory estimates include the Supernatant Treatment System.

^b Decayed to 2011.

^c Activity excludes progeny.

Sources: WVNSCO 2005, WVES 2008c.

Table C–9 Estimated Hazardous Chemical Inventory in the Waste Tank Farm

<i>Chemical</i>	<i>Tank 8D-1 (kilograms)</i>	<i>Tank 8D-2 (kilograms)</i>	<i>Tank 8D-3 (kilograms)</i>	<i>Tank 8D-4 (kilograms)</i>	<i>Lines (kilograms)</i>	<i>Total (kilograms)</i>
Silver	1.98	1.13	0.00318	0.287	0.000398	3.40
Arsenic	3.92	2.21	0.00795	0.354	0.000795	6.49
Barium	17.5	9.73	0.00636	0.287	0.00360	27.5
Beryllium	0.608	0.372	0.00757 *	0.332 *	0.000115	1.32
Cadmium	1.66	0.884	0.00159	0.0710	0.000324	2.62
Chromium	85.6	47.8	0.0401	0.934	0.0172	134
Mercury	1.15	0.640	0.000320	0.0210	0.000241	1.81
Nickel	85.9	47.7	0.0300 *	2.79 *	0.0177	136
Lead	14.2	7.97	0.0159	0.708	0.00291	22.9
Antimony	9.76	5.47	0.0151 *	0.890 *	0.00199	16.1
Selenium	4.87	2.73	0.00636	0.261	0.000993	7.87
Thallium	9.68	5.38	0.00379 *	0.415 *	0.00199	15.5

Note: Inventory estimates include the Supernatant Treatment System. To convert kilograms to pounds, multiply by 2.2046.
Source: WVES 2008c, 2008d for all values given in the table except for those with a *. The values with the * were taken from URS 2005 because no data were given in the other references.

Tanks 8D-1 and 8D-2

Tanks 8D-1 and 8D-2 are similar in size and construction, and each tank is housed within its own cylindrical concrete vault. Each tank is 8.2 meters (27 feet) high by 21.3 meters (70 feet) in diameter, with a storage capacity of 2,840,000 liters (750,000 gallons). The tanks were constructed from a reinforced carbon steel plate. The roof of each tank is supported internally by 45 20.3-centimeter-diameter (8-inch-diameter) vertical pipe columns that rest on a horizontal gridwork of wide flange beams and cross members in the bottom 0.6 meters (2 feet) of each tank. Each tank rests on two 15.2-centimeter-thick (6-inch-thick) layers of perlite blocks that rest on a 7.6-centimeter (3-inch) layer of pea gravel. The tank, perlite blocks, and pea gravel are contained within a carbon steel pan that rests on a 7.6-centimeter (3-inch) layer of pea gravel that separates the pan from the floor of the vault.

Each tank and its associated pan are housed within a cylindrical reinforced concrete vault that has an outside diameter of 23.9 meters (78.6 feet). The walls of each vault are 45.7 centimeters (18 inches) thick and extend nearly 11 meters (36 feet) above the floor of the vaults. The floor of the vault is 68.6 centimeters (27 inches) thick, except under the six 76.2-centimeter-diameter (30-inch-diameter) vertical concrete columns that support the vault roof, where the floor is thicker. These columns pass upward from the floor of the vault through the tanks and are encased in steel pipes that are welded to the top and bottom of each tank. The columns are located approximately 4.9 meters (16 feet) from the center of the tank. The floor of each vault is underlain by a 1.2-meter-thick (4-foot-thick) bed of gravel. The concrete vault roof is 0.6 meters (2 feet) thick and is supported by six concrete columns. The top of the vault is 1.8 to 2.4 meters (6 to 8 feet) below-grade. Tanks 8D-1 and 8D-2 will be emptied of any residual liquids by accelerated evaporation prior to the starting point of the EIS (WVES 2008c).

Tanks 8D-3 and 8D-4

Tanks 8D-3 and 8D-4 are identical in size and construction, and both are housed within a single concrete vault. Each tank is constructed from Type 304L stainless steel, is 3.6 meters (12 feet) in diameter and 4.8 meters (15.67 feet) high, and has a nominal volume of 56,800 liters (15,000 gallons). The shell of each tank and its associated piping were constructed from 304L stainless steel. The associated concrete vault is 9.75 meters

(32 feet) long, 5.8 meters (19 feet) wide, and 7.6 meters (25 feet) tall. The walls, floor, and roof of the vault are 0.53 meters (1.75 feet) thick. The bottom of the vault is lined with stainless steel to a height of 46 centimeters (18 inches) above the floor. The floor contains a stainless steel-lined sump that was designed to collect any liquid that could leak from the tanks and piping. The top of the vault is 1.8 to 2.4 meters (6 to 8 feet) below-grade.

In achieving the starting point of the EIS, the radiologically contaminated residual liquids in Tanks 8D-3 and 8D-4 will be processed by drying and treatment. Titanium-treated zeolite will be used to adsorb cesium-137 in the Tank 8D-4 liquid and trap a portion of the plutonium content. The titanium-treated zeolite will be packaged and shipped for offsite disposal before the starting point of this EIS (WVES 2008c).

Hazardous chemical inventories have been estimated for the Waste Tank Farm, including the four waste storage tanks and underground process lines (URS 2005, WVES 2008d). These inventories are summarized in Table C-9.

Waste Tank Pumps

Tank 8D-1 contains five waste mobilization pumps and Tank 8D-2 contains four. Tanks 8D-1 and 8D-2 each contain an STS suction pump. Each pump is approximately 2.4 meters (8 feet) long and is supported by a 25.4-centimeter (10-inch) stainless steel pipe column that is 15 meters (50 feet) long. Each pump was operated by a 150-horsepower electric motor located at the top of the pipe column. Tanks 8D-1, 8D-2, 8D-3, and 8D-4 also each contain a waste transfer pump. These centrifugal multistage turbine-type pumps are each supported by a 36-centimeter (14-inch) pipe column. The pipe columns for Tanks 8D-1 and 8D-2 have an overall length of more than 15 meters (50 feet); for Tanks 8D-3 and 8D-4, the length of the pipe column is approximately 6 to 8 meters (20 to 25 feet). Similar to the mobilization pumps, the transfer pumps were driven by 150-horsepower electric motors.

The pumps contain radioactive contamination. An order-of-magnitude estimate of the residual radioactivity in a removed pump in 1998 was approximately 220 curies, with about 90 percent of this amount in the lower 2.4-meter (8-foot) section, that is, the pump itself.

The mobilization pumps remaining in the tanks will likely be similarly contaminated. The transfer pumps will likely have more contamination because high-level radioactive waste passed through the entire length of the pump rather than only the lower portion.

Tank and Vault Drying System

The Tank and Vault Drying System will be installed to dry the liquid heels remaining in the waste tanks prior to the starting point of this EIS. Equipment for the system will include a dehumidifier and heater for air forced into the vaults. The exhaust air leaving the vaults will pass through HEPA filters. An additional enhancement to reduce corrosion inside the tanks would be to reconfigure the Tank and Vault Drying System to dry both inside the vaults and inside the tanks.

Dewatering Well

A dewatering well was installed during construction of the waste tanks and has been used on a nearly continual basis to maintain the static groundwater levels in the Waste Tank Farm Area in a depressed condition. The location of the dewatering well is approximately between Tanks 8D-1 and 8D-2, adjacent to the Permanent Ventilation System Building. Low levels of radiological contamination are present, and the water that is removed is sent to the Low-Level Waste Treatment Facility.

C.2.3.2 High-Level Waste Transfer Trench

The High-Level Waste Transfer Trench is a long concrete vault containing double-walled piping that was designed to convey waste between the Waste Tank Farm and the Vitrification Facility in WMA 1. It is approximately 152 meters (500 feet) long, extending from the Tank 8D-3/8D-4 vault along the north side of Tanks 8D-1 and 8D-2, before turning to the southwest and entering the north side of the Vitrification Facility. The trench is 1.8 to 6.1 meters (6 to 20 feet) wide, and its height ranges from 1.8 to 2.7 meters (6 to 9 feet). The High-Level Waste Transfer Trench was constructed of reinforced concrete walls and precast concrete covers. The walls of the trench are 45.7 to 61 centimeters (18 to 24 inches) thick, and the precast roof is 0.6 meters (2 feet) thick. The floor slab of the trench is 0.3-meter-thick (1-foot-thick) concrete. The transfer trench contains between two and six stainless steel lines, comprising approximately 915 linear meters (3,000 linear feet) of piping. These process lines are either 5.1 or 7.6 centimeters (2 or 3 inches) in nominal diameter and are encased within an outer containment pipe. The containment pipe is either 10.2 or 15.2 centimeters (4 or 6 inches) in diameter depending on the location and the size of the enclosed pipe.

Stainless steel-lined concrete pump pits that house the upper sections of the waste transfer pumps are located on top of each of the tank vaults. The walls of the pump pits are constructed of 0.6-meter-thick (2-foot-thick) reinforced concrete, the floors are constructed with 0.3-meter-thick (1-foot-thick) concrete, and the roofs are precast concrete covers.

The High-Level Waste Transfer Trench is not expected to be radiologically contaminated because high-level radioactive waste was conveyed in double-walled piping that did not leak during operations. Precipitation that infiltrates the transfer trench is collected at two low points along the trench and is sampled and analyzed. Contamination has not been detected in any of the water collected. A leak detection system is located between the walls of the double-walled high-level radioactive waste transfer piping. This system has not detected any releases of high-level radioactive waste from the piping. However, the pump pits and piping used to convey high-level radioactive waste are radiologically contaminated. It was estimated in 2004 that the piping within the trench contained approximately 235 curies of residual radioactivity, with the pump pits containing approximately twice that amount (WSMS 2009a). The trench is a RCRA interim status unit and is subject to RCRA closure.

C.2.3.3 Permanent Ventilation System Building

The Permanent Ventilation System Building is located approximately 15.3 meters (50 feet) north of Tank 8D-2. This steel-framed and -sided building is 12.2 meters (40 feet) wide, 23 meters (75 feet) long, and 4.9 meters (16 feet) tall and is supported by a concrete foundation and slab. The concrete floor slab is 0.3 meters (1 foot) thick. It contains four rooms: the Permanent Ventilation System Room, Electrical Room, Mechanical Room, and Control Room. The Permanent Ventilation System Building has a sheet metal roof that supports the Permanent Ventilation System Discharge Stack. The Permanent Ventilation System is designed to provide ventilation to the STS Support Building; STS Valve Aisle; STS Pipeway; and Tanks 8D-1, 8D-2, 8D-3, and 8D-4. Airflow from these facilities is directed to the Permanent Ventilation System, where it passes through a mist eliminator, heater, roughing filter, and two sets of HEPA filters before being discharged through the Permanent Ventilation System Stack to the atmosphere.

A small, recently built, skid-mounted Permanent Ventilation System Stack Monitoring Building is located near the east end of the Permanent Ventilation System Building. Insulated sampling lines lead to and from the Permanent Ventilation System Stack.

The Permanent Ventilation System Building contains an aboveground and a belowground petroleum storage tank, both of which would require closure under 6 NYCRR Part 613 regulations.

The Permanent Ventilation System Building is divided into four main rooms, none of which contain surface contamination. Most of the residual contamination in this building is in the two HEPA filters, which could contain as much as 7.5 curies of cesium-137 and much smaller amounts of other radionuclides. No hazardous contamination is expected.

C.2.3.4 Supernatant Treatment System and Supernatant Treatment System Support Building

The STS was installed to support the solidification of the liquid high-level radioactive wastes stored in Tanks 8D-2 and 8D-4. The STS was installed in and adjacent to Tank 8D-1. The STS was a zeolite molecular sieve system designed to strip cesium, the principal radioactive species, from the PUREX/THOREX supernatant and sludge-wash solutions and highly radioactive wastewaters from the Liquid Waste Treatment System. It also removed lesser quantities of strontium and plutonium. During 2003, the STS was also used to process sodium-bearing wastewater from Tanks 8D-1 and 8D-2. The STS equipment installed in Tank 8D-1 (and the only STS equipment coming in contact with high-level radioactive waste) includes an STS prefilter, supernatant feed tank, supernatant cooler, four zeolite columns, STS sand post filter, sluice lift tank, and associated transfer piping.

At the starting point of this EIS, the STS Support Building will be operational. The STS Support Building is located adjacent to Tank 8D-1. It is a two-story structure that contains equipment and auxiliary support systems needed to operate the STS. The upper level of the STS Support Building, extending from a site reference elevation of 32.6 meters (107 feet) to the roof peak at 39.3 meters (129 feet), is a steel-framed work structure covered with steel siding. The lower level of the STS Support Building, extending from 28 to 32.6 meters (92 to 107 feet), was constructed with reinforced concrete walls, floor, and ceiling. This building, with the exception of the Valve Aisle, is a radiologically clean structure that contains a Control Room; heating, ventilation, and air conditioning equipment; utilities; and storage tanks for freshwater and fresh zeolite to support STS operations. The STS Support Building was built on 68 cast-in-place concrete piles. Each pile was installed to a minimum depth of 4.6 meters (15 feet) into the Lavery till unit. These piles were installed to provide additional structural support to the STS Support Building because the backfill soil around Tanks 8D-1 and 8D-2 was not compacted after the tanks were built.

A shielded Valve Aisle is located on the first floor of the STS Support Building adjacent to Tank 8D-1. This Valve Aisle contains remotely operated valves and instrumentation used to control operation of the STS. The shield walls of the Valve Aisle were constructed of 30.5-centimeter-thick (12-inch-thick) carbon steel, and the ceiling was made from 35.6-centimeter-thick (14-inch-thick) carbon steel. The shield walls and ceiling are composed of three individual steel plates that are bolted together. The Valve Aisle is radiologically contaminated. Removable hatches above the Valve Aisle provide access to the aisle for removal of large items.

The STS Pipeway is located on top of the Tank 8D-1 Vault. This concrete and steel structure contains STS piping and structural members that support the STS equipment in Tank 8D-1.

The STS and support building are RCRA interim status units and are subject to RCRA closure.

C.2.3.5 Equipment Shelter and Condensers

The Equipment Shelter is a one-story, concrete block building located immediately north of the Vitrification Facility. The Equipment Shelter is 12.2 meters (40 feet) long, 5.5 meters (18 feet) wide, and 3.6 meters (12 feet) high, and has a concrete floor that is 15.3 centimeters (6 inches) thick. A small extension on the west side of the Equipment Shelter is approximately 2.7 meters (9 feet) long, 2.1 meters (7 feet) wide, and 1.5 meters (5 feet) high, with a 0.3-meter-thick (1-foot-thick) concrete floor. The roof decking covering this structure is 10.2 centimeters (4 inches) thick.

The Equipment Shelter houses the Waste Tank Farm Ventilation System that was formerly used to ventilate the four waste storage tanks (8D-1, 8D-2, 8D-3, and 8D-4) and the STS Vessels in Tank 8D-1 before the Permanent Ventilation System Building began operations. Air from these tanks formerly passed through one of two condensers, a knockout drum, a heater, and two sets of HEPA filters before being discharged through the Main Stack of the Main Plant Process Building. Most of the radiological inventory in the Equipment Shelter is expected to be present in the ventilation system equipment.

Airflow from Tanks 8D-3 and 8D-4 is currently piped to the Equipment Shelter, where it passes through the Waste Tank Farm Caustic Scrubber and the Waste Tank Farm Condensate Tank and is then directed back through the condensers to a line, where it continues to the Permanent Ventilation System Building for treatment.

The condensers are located west of the Equipment Shelter and were originally designed to condense the overheads from Tanks 8D-1 and 8D-2, which were designed to be in a self-boiling condition during operations. The condensed overheads were directed to the Waste Tank Farm Condensate Tank and to an ion-exchange unit in the Low-Level Waste Treatment Facility for additional treatment before discharge to Erdman Brook. The condensers are contaminated with small amounts of radioactivity, and are identified as SWMUs; however, it has been determined that no further action is required.

C.2.3.6 Con-Ed Building

The Con-Ed Building is a concrete block building located on top of the concrete vault containing Tanks 8D-3 and 8D-4. This building, which is 3 meters (10 feet) wide, 4 meters (13 feet) long, and 3.4 meters (11 feet) high, houses the instrumentation and valves used to monitor and control the operation of Tanks 8D-3 and 8D-4. The Con-Ed Building is radiologically contaminated. The majority of the radiological inventory is believed to be contained in the piping and equipment inside the building. The Con-Ed Building is identified as a SWMU; however, it has been determined that no further action is required.

C.2.3.7 Underground Pipelines

At the starting point of this EIS, the underground pipelines within WMA 3 will still be in place. The pipes were used to carry radioactive liquids, PUREX and THOREX wastes, and ventilation exhaust air. Most of the pipes are expected to be radioactively contaminated.

C.2.4 Waste Management Area 4: Construction and Demolition Debris Landfill

WMA 4, shown on **Figure C-5**, is a 4-hectare (10-acre) area in the northeast portion of the North Plateau of WVDP. It includes the Construction and Demolition Debris Landfill (CDDL), which is the only waste management unit in WMA 4. WMA 4 is located in the path of the North Plateau Groundwater Plume, which also extends through WMAs 1, 2, 3, 5, and 6. The plume is described in Section C.2.13. The western part of WMA 4 was impacted by the stack releases that produced the Cesium Prong, which is discussed in Section C.2.14.

The CDDL covers a 0.6-hectare (1.5-acre) area approximately 305 meters (1,000 feet) northeast of the Main Plant Process Building. The CDDL was initially used by Bechtel Engineering from 1963 to 1965 to dispose of nonradioactive waste generated during Bechtel's construction of the Main Plant Process Building. NFS used the CDDL from 1965 to 1981 to dispose of nonradioactive construction-, office-, and facility-generated debris, including ash from the NFS incinerator. The CDDL was used by DOE from 1982 to 1984 to dispose of nonradioactive waste. Typically, the wastes were placed on existing grade in 0.9- to 1.5-meter-thick (3- to 5-foot-thick) lifts, covered with soil, and compacted with bulldozers or trucks. The CDDL is estimated to contain a total volume of 12,000 cubic meters (425,000 cubic feet) of waste material and soil.

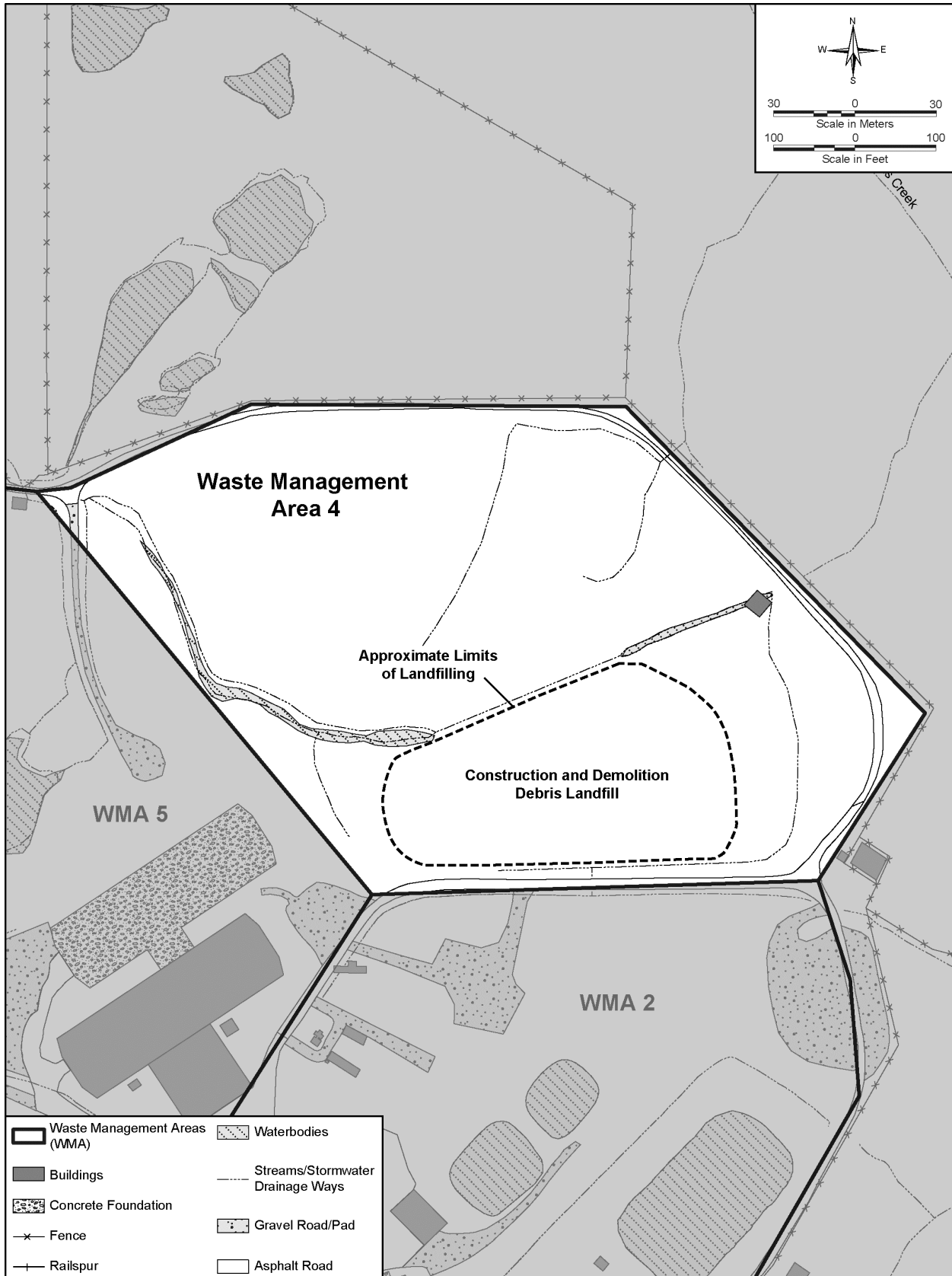

Figure C-5 Waste Management Area 4 – Construction and Demolition Debris Landfill

Disposal operations in the CDDL were terminated in December 1984, and the landfill was closed in accordance with New York State regulations in effect at the time of closure. The final cover on the CDDL consists of a minimum of 45.7 centimeters (18 inches) of compacted soil, which was covered with at least 15.2 centimeters (6 inches) of topsoil capable of sustaining plant growth. The entire cover was graded to achieve a minimum slope of two percent. During October 1986, NYSDEC approved and certified the closure of the CDDL. The CDDL is identified as a SWMU subject to corrective action requirements pursuant to the RCRA 3008(h) Consent Order. A Corrective Measures Study is being prepared.

The CDDL is located in the flow path of the North Plateau Groundwater Plume, described in Section C.2.13. Because radioactively contaminated groundwater in the plume is assumed to have come in contact with the waste buried in the CDDL, the buried wastes are assumed to require handling as radioactive wastes. In addition, volatile organic compounds have been detected in groundwater downgradient of the CDDL.

C.2.5 Waste Management Area 5: Waste Storage Area

WMA 5, the Waste Storage Area, is shown on **Figure C-6**. It encompasses approximately 7.6 hectares (19 acres). Facilities in WMA 5 that will be operational or standing at the starting point of this EIS are the Remote-Handled Waste Facility, Lag Storage Area 4 with the associated Shipping Depot, and the Construction and Demolition Area. Included in WMA 5 is a portion of the North Plateau Groundwater Plume, which also extends through WMAs 1, 2, 3, 4, and 6. It is described in Section C.2.13

At the starting point of this EIS, the Lag Storage Building; Lag Storage Areas 1, 2, and 3; Hazardous Waste Storage Lockers; and Chemical Process Cell Waste Storage Area will have been removed to grade. The disposition of the remaining concrete foundations and slabs is analyzed in this EIS. In addition, the Cold Hardstand near the CDDL, Vitrification Vault and Empty Container Hardstand, Old/New Hardstand Area, Waste Packaging Area, Lag Hardstand, High-Level Waste Tanks Pump Storage Vaults, and Container Sorting and Packaging Facility will have been completely removed. However, the ground underneath these facilities could be radioactively contaminated and would be subject to decommissioning activities.

C.2.5.1 Remote-Handled Waste Facility

At the starting point of this EIS, the Remote-Handled Waste Facility will have been decontaminated to a point where it could be demolished without containment.

The Remote-Handled Waste Facility was included as a containment building in the RCRA Part A permit application for WVDP (Revision 3, June 29, 2001). In accordance with 6 NYCRR Subpart 373-1.5, this updated interim status permit application was transmitted to NYSDEC for review. NYSDEC subsequently approved this permit revision in a November 13, 2001, correspondence. In June 2004, the Remote-Handled Waste Facility became operational as a containment building subject to the operational requirements specified in 6 NYCRR Subpart 373-3.30. The Remote-Handled Waste Facility comprises a Receiving Area, Buffer Cell, Work Cell, Waste Packaging Area, Operating Aisle, Batch Transfer Tank, and Load-Out/Truck Bay. The Receiving Area includes an 18-metric ton (20-ton) bridge crane that also provides access into the adjacent Buffer Cell.

The Buffer Cell is an air lock between the Receiving Area and the contaminated Work Cell. The floor in the Buffer Cell is at the same height as the floor in the Work Cell. Power rollers move waste containers from the Buffer Cell into the Work Cell. A shield window is located in the wall, allowing direct observation into the Buffer Cell. Both ends of the Buffer Cell have sliding shield doors and horizontal swinging contamination control doors.

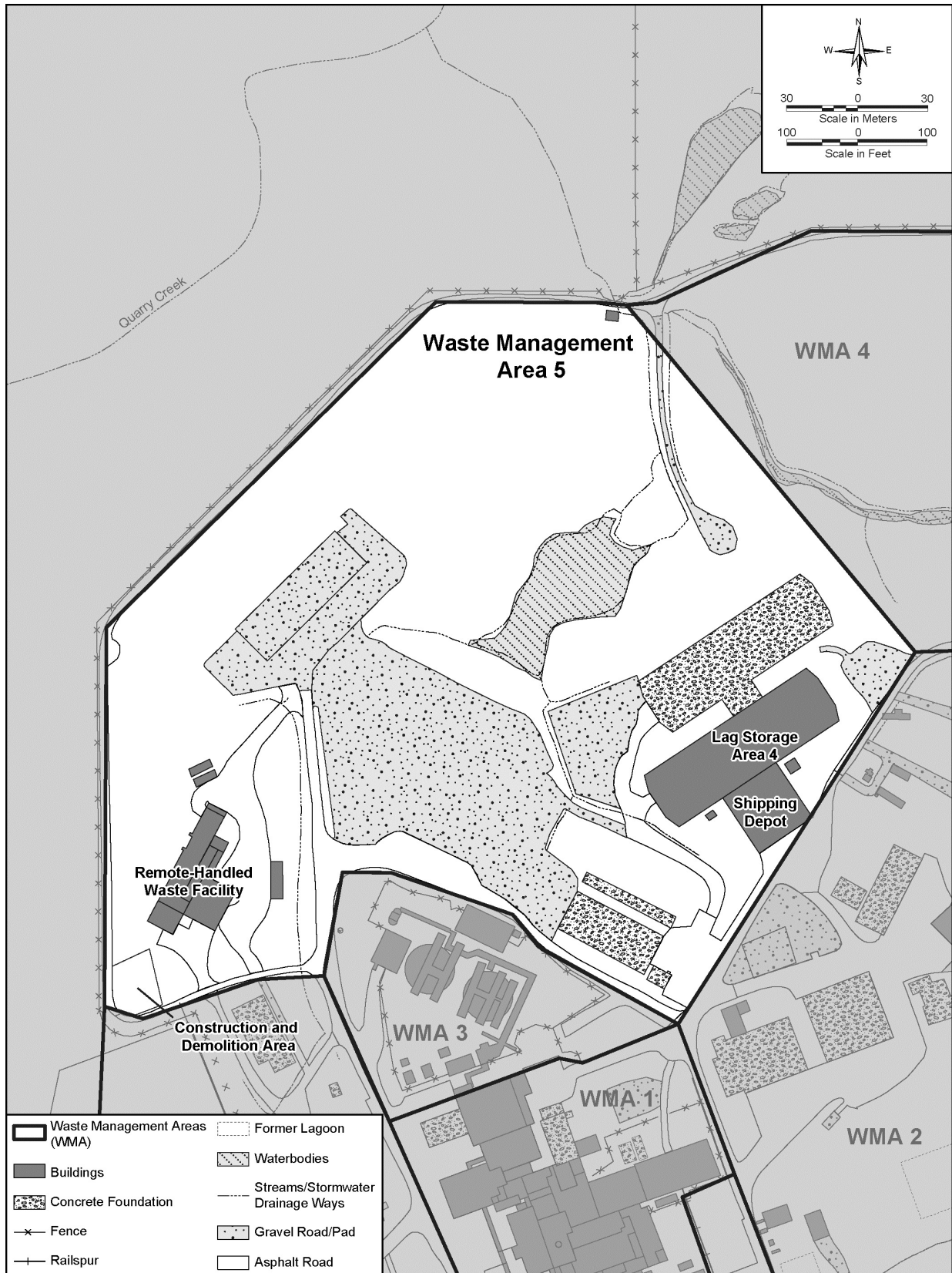

Figure C-6 Waste Management Area 5 – Waste Storage Area

The Work Cell is the primary work zone within the Remote-Handled Waste Facility, with provisions for remote-handling, surveying, segmenting, decontaminating, and repackaging operations. The shielded space is 16.8 meters (55 feet) by 6.7 meters (22 feet) by 7.9 meters (26 feet) high and is served by a 27-metric ton (30-ton) bridge crane. Two powered dexterous manipulator arms are supported by bridge crane trolleys. One jib crane with powered dexterous manipulators is mounted on rails along the long wall over the shield windows. Below-grade wastewater storage tanks could receive spent decontamination solutions containing radiological and chemical contamination prior to the starting point of the EIS. Workstations are located at each shield window. The Work Cell, equipment within it, and the wastewater tanks are expected to be radiologically and chemically contaminated from operations performed within the cell.

The Waste Packaging Area includes the capability to load both waste drums and boxes. The area is expected to be kept radiologically clean, but due to the fact that filled waste containers are handled in this area, low levels of radioactive contamination are possible.

The Operating Aisle houses two waste processing and packaging workstations and one waste sampling transfer workstation. Each workstation includes a 55.9-centimeter-thick (22-inch-thick) oil-filled shield window in the shield wall and controllers for remote operation of facility equipment. The Operating Aisle is expected to be kept radiologically clean, but because filled waste containers are handled in this area, low-level contamination is possible.

The Batch Transfer Tank located in the tank vault is a 5,680 liter (1,500 gallon) tank installed to transfer wash down water batches to the on-site Liquid Waste Treatment Facility via Tank 8D-3. Double walled piping connects the Batch Transfer Tank to Tank 8D-3.

The Remote-Handled Waste Facility is a RCRA interim status unit and is subject to RCRA closure.

C.2.5.2 Lag Storage Area 4

Lag Storage Area 4 is used for storing, sorting, and repackaging low-level radioactive waste and mixed low-level radioactive waste. Lag Storage Area 4 includes a Shipping Depot and a covered passageway that leads to Lag Storage Area 3. The Shipping Depot, a 28- by 26-meter (91- by 85-foot) metal-framed structure, is connected to Lag Storage Area 4. Lag Storage Area 4 is potentially contaminated: low levels of radioactive contamination are expected in soil beneath the building from historical activities and the North Plateau Groundwater Plume. If contamination is encountered in Lag Storage Area 4, it is expected to be minimal due to packaging requirements and storage practices. Lag Storage Area 4 is a RCRA interim status unit and is subject to RCRA closure.

C.2.5.3 Construction and Demolition Area

The Construction and Demolition Area is a 7.6- by 7.6-meter (25- by 25-foot) shallow ground depression located southwest of the Remote-Handled Waste Facility, approximately 91 meters (300 feet) west of the STS Support Building. This area is also known as the Concrete Washdown Area. From 1990 to June 1994, waste concrete was deposited in this area during the cleanout of concrete mixing trucks that transported concrete from offsite sources to support WVDP construction projects such as the Vitrification Facility. The waste concrete generated during truck washing was staged in this area until it hardened, after which it was placed in a dumpster for offsite disposal. Residual concrete is the only waste that was managed in this area, as the Construction and Demolition Area was not used for any other type of waste treatment or management. The Construction and Demolition Area is identified as a SWMU; however, it has been determined that no further action is required.

C.2.6 Waste Management Area 6: Central Project Premises

WMA 6, the Central Project Premises, is shown on **Figure C-7**. It encompasses approximately 5.7 hectares (14 acres). Facilities that will be standing, operable, or operational at the starting point of this EIS in WMA 6 include two Demineralizer Sludge Ponds and the Rail Spur, Equalization Basin, Equalization Tank, Low-Level Radioactive Waste Rail Packaging and Staging Area, Sewage Treatment Plant, and South Waste Tank Farm Test Tower. Included in WMA 6 is a portion of the North Plateau Groundwater Plume, which also extends through WMAs 1 through 5.

At the starting point of this EIS, the Old Warehouse, Cooling Tower, North Waste Tank Farm Test Tower, Road Salt and Sand Storage Shed, Vitrification Test Facility Waste Storage Area, and Product Storage Area will have been removed to grade. The disposition of the remaining concrete foundations and slabs is analyzed in this EIS. Any radioactively contaminated ground underneath these facilities would be subject to decommissioning.

C.2.6.1 Rail Spur

The Rail Spur runs about 2,440 meters (8,000 feet) from the south side of the Main Plant Process Building to where it connects to the main line of the railroad. The southernmost portion of the spur is located in WMA 12. The rails are hot-rolled steel and the ties are creosote pressure-treated wood. Low-level radiological soil contamination, measuring 13 picocuries of cesium-137 per gram, has been detected in a 9.1- by 30.5-meter (30- by 100-foot) area along a section of dual track east of the Old Warehouse. The volume of the contaminated soil has been estimated at about 105 cubic meters (3,700 cubic feet).

C.2.6.2 Demineralizer Sludge Ponds

The Demineralizer Sludge Ponds were built between 1964 and 1965 during construction of the Main Plant Process Building on the North Plateau. The sludge ponds are two unlined rectangular basins located southeast of the Main Plant Process Building. Each pond is 15 by 30 meters (50 by 100 feet) and approximately 1.5 meters (5 feet) deep. The ponds were designed to discharge through a weir box and underground piping to an SPDES-permitted outfall.

The Demineralizer Sludge Ponds were designed to receive discharge solutions backflushed from the process water demineralizer and water softener and sludge from the raw water clarifier. During 1971, radioactive solutions backflowed into the demineralizer. Although the demineralizer units were replaced and effluent routed to the Low-Level Waste Treatment Facility, this episode contaminated sediments in the sludge ponds. Until 1985, only the North Pond was used when the effluent mixing basin was brought on line. From 1985 to 1994, only the South Pond was used to receive water softener regeneration and clarifier blowdown. The Demineralizer Sludge Ponds have remained inactive since June 1994 (WVNS 1993, WVNSCO 2004).

Both ponds are radiologically contaminated. Cesium-137 has been detected in the top 0.9 meters (3 feet) of sediment in the North Pond and in the top 0.6 meters (2 feet) of the South Pond. Nine semivolatile chemicals were detected in sediment in the North Demineralizer Sludge Pond at concentrations below regulatory levels. The Demineralizer Sludge Ponds are identified as a SWMU subject to corrective action requirements pursuant to the RCRA 3008(h) Consent Order. A Corrective Measures Study is being prepared.

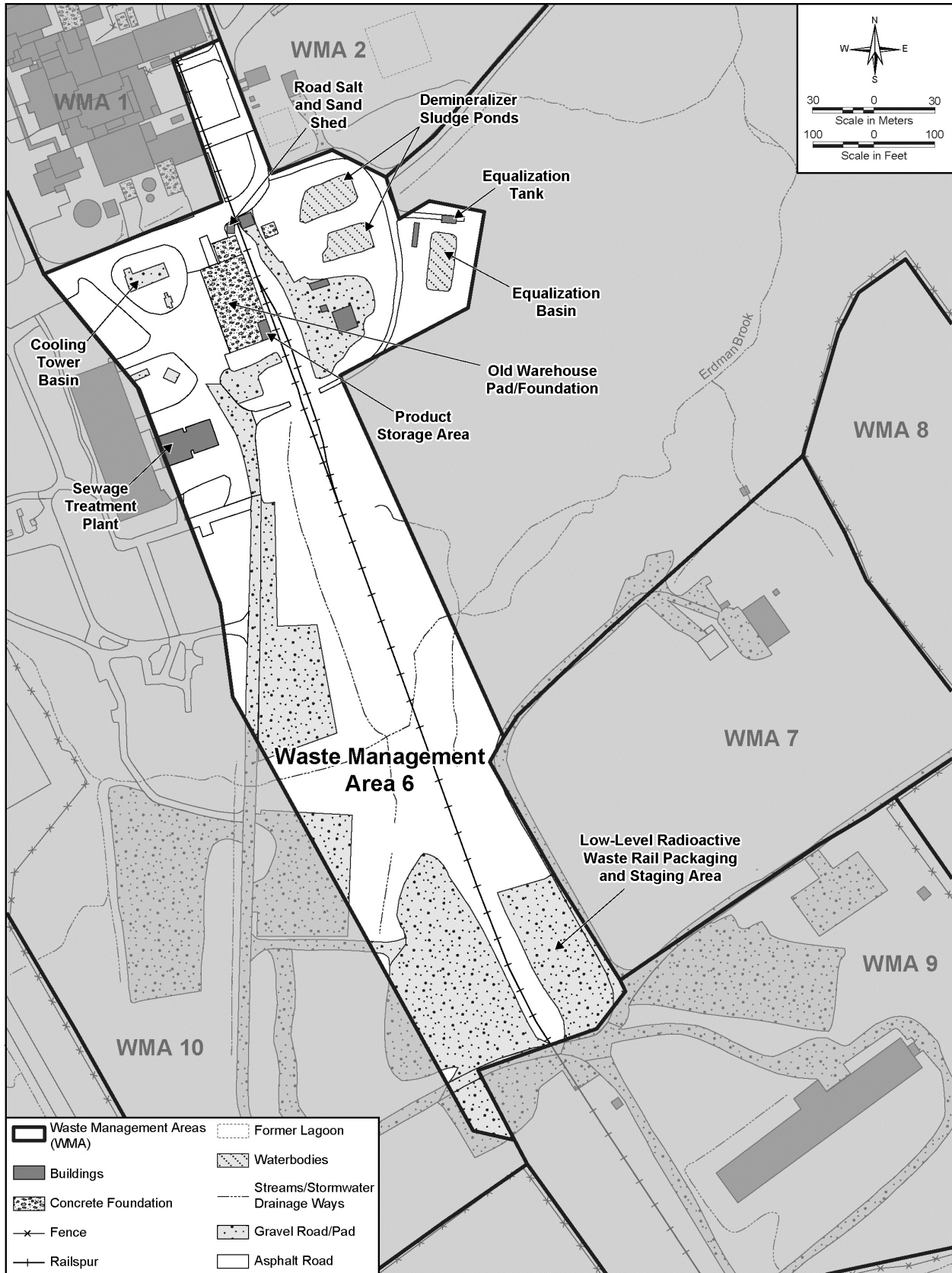

Figure C-7 Waste Management Area 6 – Central Project Premises

C.2.6.3 Equalization Basin

The Equalization Basin is a lined basin that is 22.9 meters (75 feet) wide, 38.1 meters (125 feet) long, and 3 meters (10 feet) deep. The basin is excavated into the sand and gravel layer and underlain with a sand drain. Originally, the basin was called the Effluent Mixing Basin; it received effluents from the Sanitary Sewage Treatment Plant, some discharge from the Utility Room, and cooling water blowdown. Later it received effluents from the Demineralizer Sludge Ponds. The basin currently is used as an excess capacity settling pond for discharges from the Utility Room. Based on sludge sampling, no hazardous or radiological contamination is present in the Equalization Basin. The Equalization Basin is identified as a SWMU and is subject to Clean Water Act corrective action and closure requirements.

C.2.6.4 Equalization Tank

The Equalization Tank was installed in 1997 to work in parallel with the Equalization Basin. The Equalization Tank is an inground concrete tank that was designed with a total capacity of 75,700 liters (20,000 gallons) and a maximum working capacity of 56,800 liters (15,000 gallons). The tank is sloped to the east to allow gravity to affect flow through it. The function of the tank is identical to the Equalization Basin, except that the Equalization Tank would be less affected by the rapid cooling of wastewaters during rapid temperature drops.

C.2.6.5 Low-Level Radioactive Waste Rail Packaging and Staging Area

The Low-Level Radioactive Waste Rail Packaging and Staging Area covers approximately 2,510 square meters (27,000 square feet) east of and adjacent to the railroad tracks at the south end of WMA 6. The area contains two 20-centimeter-thick (8-inch-thick) reinforced concrete pads. The concrete loading dock measures 7.3 by 27.4 meters (24 by 90 feet), and the concrete preparation area measures 7.3 by 18.3 meters (24 by 60 feet). The remaining area is covered with upwards of 0.9 meters (3 feet) of crushed limestone. The Low-Level Radioactive Waste Rail Packaging and Staging Area was used to package and ship contaminated soil stored in roll-off containers and to stage and ship Drum Cell waste drums. This area is not expected to be radiologically contaminated based on its operational history. Waste materials were not typically removed from waste packages.

C.2.6.6 Sewage Treatment Plant

The Sewage Treatment Plant is a wood-framed structure that is 12.5 meters (41 feet) wide by 13.4 meters (44 feet) long by 4.7 meters (15 feet) high, with metal siding and roofing. The base of the facility is concrete and crushed stone. Eight tanks are associated with the plant: six inground concrete tanks, one aboveground polyethylene tank, and one aboveground stainless steel tank. The Sewage Treatment Plant is used to treat sanitary and nonradiological, nonhazardous industrial wastewater generated by WVDP. Water treatment chemicals, such as sulfuric acid, sodium hypochlorite, sodium bisulfite, and sodium bicarbonate, have been used at the plant. The Sewage Treatment Plant also previously contained a satellite accumulation area that stored mercury-bearing RCRA hazardous waste from the Main Plant Process Building. No hazardous or radiological contamination is known to exist there. Treated wastewater from the Sewage Treatment Plant is discharged to Erdman Brook through an SPDES-permitted outfall. The Sewage Treatment Plant is identified as a SWMU and is subject to Clean Water Act corrective action and closure requirements.

C.2.6.7 Waste Tank Farm Test Towers

The Waste Tank Farm Test Towers, also known as training platforms, consist of two test towers. The Waste Tank Farm Test Towers were used to train workers in preparation for removal of pumps from the high-level waste tanks. The North Test Tower will have been removed at the starting point of this EIS. The South Test Tower is the decant pump and heat exchanger platform. It is a pre-engineered structure erected as a stack of six modules, including ladders, handrails, and grating. Structural shapes and plates are carbon steel. The exterior “skin” is fabric. The South Test Tower is not radiologically or chemically contaminated.

C.2.7 Waste Management Area 7: NRC-Licensed Disposal Area and Associated Facilities

WMA 7, which includes the NDA, is shown on **Figure C–8**; the locations of NDA burial areas are shown on Figure C–21. WMA 7 encompasses approximately 3.3 hectares (8 acres) and includes the radioactive waste disposal area and ancillary structures. The NDA is about 122 meters (400 feet) wide and 183 meters (600 feet) long within WMA 7. The NDA is divisible into three distinct areas: the NFS disposal area, known as special holes and deep burial holes; the WVDP disposal trenches and caissons; and the area occupied by the Interceptor Trench and the associated Liquid Pretreatment System structures. Other ancillary structures in the NDA include a Leachate Transfer Line, a former lagoon, and the NDA Hardstand Staging Area.

At the starting point of this EIS, the NDA Hardstand Staging Area will have been removed to grade. It is assumed for this EIS that radiological contamination is present based on past usage. The removal of the remaining gravel foundation is analyzed in this EIS.

In late 2008, infiltration mitigation measures consisting of an upgradient barrier wall and a geomembrane cover over the NDA were installed as an Interim Measure under the 3008(h) Consent Order. The design is similar to that installed over the State-Licensed Disposal Area (SDA) in 1995. The decommissioning of the barrier wall and the geomembrane cover is analyzed in this EIS.

The NDA was operated by NFS, under license from the NRC (formerly the U.S. Atomic Energy Commission), for disposal of solid radioactive waste generated from fuel reprocessing operations. Beginning in 1966, solid radioactive waste materials from the nearby Main Plant Process Building exceeding 200 millirad per hour and other materials not allowable in the SDA were buried in holes and filled with appropriate clean backfill material.

Between 1966 and 1981, NFS disposed of a variety of wastes in a U-shaped area along the eastern, western, and northern boundaries of the NDA. A total of approximately 4,620 cubic meters (163,000 cubic feet) of wastes were disposed of in the NDA by NFS (URS 2000). After establishment of WVDP, approximately 5,660 cubic meters (200,000 cubic feet) of low-level radioactive waste generated from decontamination and decommissioning activities were disposed of in the NDA between 1982 and 1986 (URS 2000). Most of these wastes were placed in trenches located in the unused parcel of land located interior to the U-shaped disposal area used by NFS. Contaminated wastes were confined to the NFS and WVDP disposal area and the Interim Waste Storage Facility. That facility and the associated pad have been clean closed and removed. No waste has been buried at the NDA since 1986.

The NFS deep holes and special holes, and the WVDP trenches and caissons, NDA Interceptor Trench, Liquid Pretreatment System, Leachate Transfer Line, and former NDA lagoon are all SWMUs and are subject to corrective action requirements pursuant to the RCRA 3008(h) Consent Order. A Corrective Measures Study is being prepared.

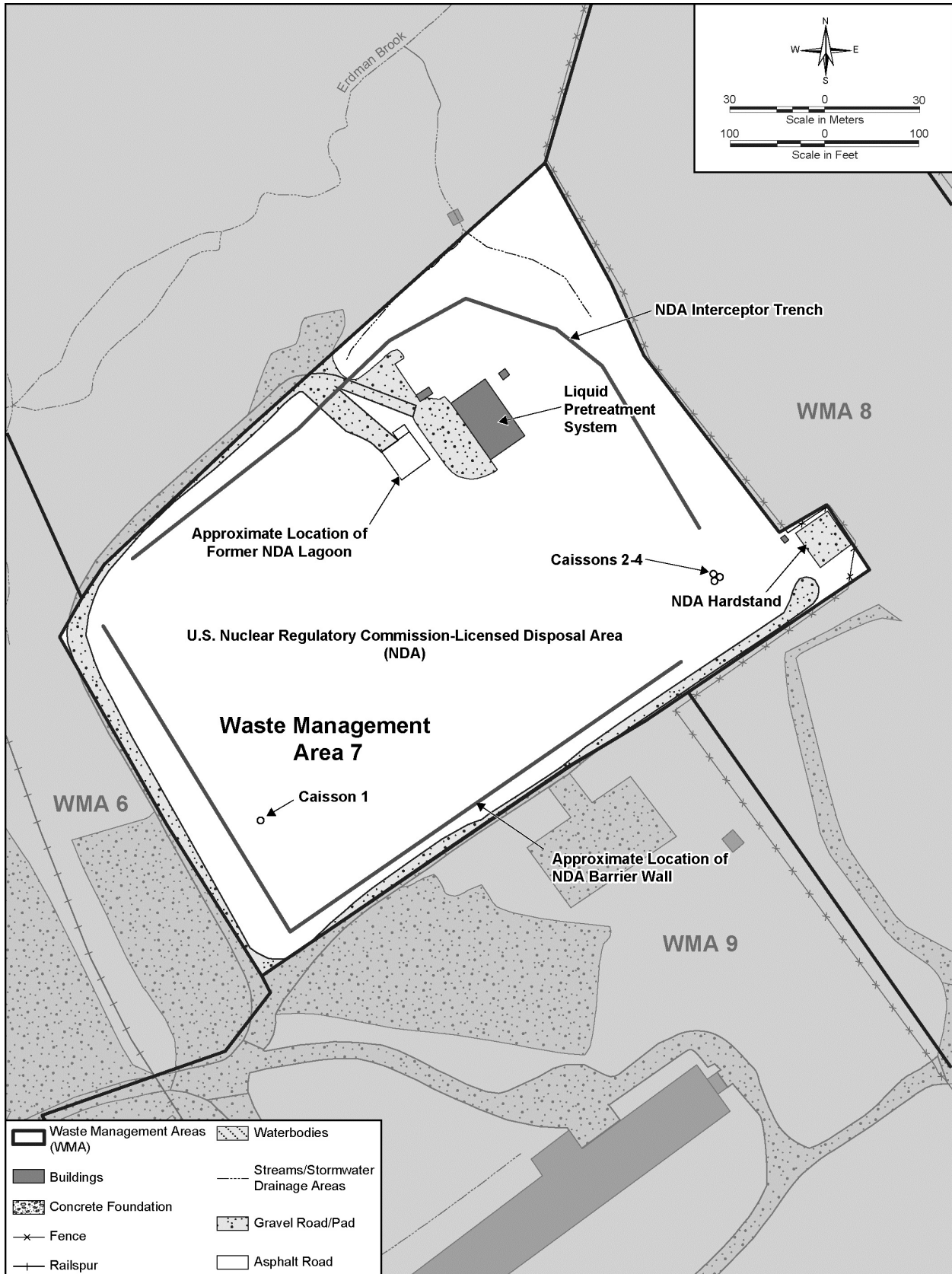

Several aspects of the NDA would need to be addressed during decommissioning: NFS and WVDP buried wastes in the disposal area; leachate in the disposal areas; contaminated soil within the NDA; and contaminated groundwater under the NDA. Leachate is known to exist in the NDA disposal holes and trenches. It would consist of water contaminated with both radiological and chemical constituents leached from the buried wastes. It is estimated that approximately 3.8 million liters (1 million gallons) of leachate would require treatment for the NDA buried waste to be either exhumed or stabilized (WSMS 2009e). A Corrective Measures Study is being prepared for the NDA (see Chapter 3, Section 3.3.2).

C.2.7.1 Disposal Areas Within the NRC-Licensed Disposal Area

Nuclear Fuel Services Deep Holes

About 187 cubic meters (6,600 cubic feet) of leached cladding, also known as hulls, from reprocessed fuel are in approximately 100 deep disposal holes located in the eastern portion of the U-shaped area. Many of these holes are 0.8 by 2 meters (2.7 by 6.5 feet) in area and 15 to 21 meters (50 to 70 feet) deep. Generally, the hulls are in 113-liter (30-gallon) steel drums and are stacked three abreast in deep narrow holes. Three of the 113-liter (30-gallon) drums contain irradiated unprocessed New Production Reactor fuel with damaged cladding. The three drums containing this fuel are in concrete at the bottom of one of the deep holes.

Because the NDA was licensed to permit burial of all waste generated as a result of the operation and maintenance of the reprocessing plant, other plant wastes, including low-level solid wastes, were disposed of in the leached hull disposal area.

The NRC imposed a requirement that the top of each stack of hull cans be limited to a height of 1.2 meters (4 feet) below the top of the weathered Lavery till.

The waste inventory in the NFS deep holes consists of approximately 1,840 cubic meters (65,000 cubic feet) of waste (URS 2000).

Nuclear Fuel Services Special Holes

Approximately 230 NFS special holes are located in the northern and western portions of the U-shaped NFS burial area. The special holes are typically about 6 meters (20 feet) deep, but have various lengths and widths. Most of the special holes are about 3.6 meters (12 feet) wide and 6 to 9 meters (20 to 30 feet) long. The lengths and widths of each special hole were varied according to the quantity of waste requiring disposal at each disposal event and the dimensions of large waste items, such as failed equipment. Miscellaneous wastes, other than leached hulls or related spent nuclear fuel debris, are in several types of containers, including steel drums, wooden crates, and cardboard boxes.

During 1983, a mixture of n-dodecane and tributyl phosphate was observed in a monitoring well at the perimeter of the NDA. It contained slight amounts of radioactivity, indicating that it was spent extractant from the fuel reprocessing operations conducted by NFS. An investigation revealed that the contamination source was eight 3,790-liter (1,000-gallon) tanks containing an absorbed mixture of n-dodecane and tributyl phosphate previously disposed of in NDA Special Holes 10 and 11. During 1986, Special Holes 10 and 11 were excavated, the eight tanks were dismantled and either disposed of off site or stored awaiting offsite disposal, and the holes were backfilled.

The waste inventory in the NFS special holes consists of approximately 2,750 cubic meters (97,000 cubic feet) of waste (URS 2000).

West Valley Demonstration Project Trenches

The 12 WVDP trenches contain approximately 5,660 cubic meters (200,000 cubic feet) of low-level radioactive waste resulting from decontamination activities performed between 1982 and 1986. Most of these wastes are in the parcel of land located interior to the U-shaped disposal area used by NFS.

The WVDP trenches are typically about 9 meters (30 feet) deep and about 4.6 meters (15 feet) wide. The lengths vary from 9 to 76 meters (30 to 250 feet). Trenches 9 and 11 have composite liners and caps. All other WVDP trenches are capped with clay.

West Valley Demonstration Project Caissons

Four steel-lined concrete caissons (cylindrical concrete vaults), 2.1 meters (7 feet) in diameter and 18.3 meters (60 feet) deep, were constructed near the eastern and southern corners of the NDA. WVDP disposal records indicate approximately 23.3 cubic meters (823 cubic feet) of waste in drums were placed in Caisson 1 (URS 2000). However, WVDP disposal records do not indicate that any waste was placed in the other three caissons. The caissons are plugged with concrete for shielding and covered with a plastic shield to prevent rainwater infiltration.

Radionuclide and Chemical Inventories in the Entire NRC-Licensed Disposal Area

The estimated radionuclide inventory of the buried waste associated with NFS and WVDP disposal operations at the starting point of this EIS is provided in **Table C–10**.

Table C–10 Estimated Radionuclide Inventory of the Buried Waste at the NRC-Licensed Disposal Area

<i>Radionuclide</i>	<i>Estimate^a (curies)</i>	<i>Radionuclide</i>	<i>Estimate^a (curies)</i>	<i>Radionuclide</i>	<i>Estimate^a (curies)</i>
Tritium	35.1	Cesium-137	28,500	Plutonium-238	347
Carbon-14	516	Radium-226	0.00000420	Plutonium-239	579
Cobalt-60	6,990	Uranium-233	11.3	Plutonium-240	398
Nickel-63	107,000	Uranium-234	0.588	Plutonium-241	9,010
Strontium-90	22,200	Uranium-235	0.120	Americium-241	1,960
Technetium-99	10.3	Uranium-238	1.46		
Iodine-129	0.0215	Neptunium-237	0.167		

NRC = U.S. Nuclear Regulatory Commission.

^a Decayed to 2011.

Source: URS 2000.

An estimate of the hazardous chemical inventory associated with NFS and WVDP disposal operations was prepared (SAIC 2005a), with emphasis on the chemicals that are important for estimating risk to receptors downgradient of the NDA. **Table C–11** presents the estimated inventories of the organic chemicals and metals in the wastes.

C.2.7.2 Interceptor Trench and Liquid Pretreatment System

The Interceptor Trench and associated Liquid Pretreatment System were installed after groundwater contaminated with tributyl phosphate, n-dodecane, and several radionuclides was detected in a well downgradient of the NDA. The Interceptor Trench was designed to intercept potentially contaminated groundwater migrating from the NDA.

**Table C–11 Estimated Hazardous Chemical Inventory of the Buried Waste at the
NRC-Licensed Disposal Area**

<i>Chemical</i>	<i>Contamination (kilograms)</i>	<i>Chemical</i>	<i>Contamination (kilograms)</i>
Phenol	0.030	2-methylnaphthalene	6.7
1,4 dioxane	1.6	Isobutyl alcohol	1.7
Bis (2-ethylexyl) phthalate	110	1,2-dibromo-3-chloropropane	3.2
Di-n-butyl phthalate	0.015	Lead	980
1-butanol	150	Mercury	8.6
Acetone	1.1	Arsenic	160
2-hexanone	1.6	Cadmium	1.8

NRC = U.S. Nuclear Regulatory Commission.

Note: To convert kilograms to pounds, multiply by 2.2046.

Source: SAIC 2005a.

The trench is located on the northeast and northwest boundaries of the disposal area. The depth of the trench is approximately 3.3 to 4.3 meters (11 to 14 feet) below ground surface over its entire length. The base of the trench extends to a minimum of 0.3 meters (1 foot) below the interface of the weathered till with the unweathered till. The trench is drained by a pipe that directs accumulated water to a collection sump. The collection sump has a submersible pump to transfer groundwater to the Liquid Pretreatment System. Liquid that collects in the sump is routinely sampled, analyzed, and transferred to the Low-Level Waste Treatment Facility in WMA 2 for treatment and release. Treated wastewater is discharged from Lagoon 3 in WMA 2 to Erdman Brook through an SPDES-permitted outfall.

The Liquid Pretreatment System consists of seven tanks made of carbon steel: one 18,900-liter (5,000-gallon) holding tank, two 3,790-liter (1,000-gallon) prefiltration holding tanks, two 2,650-liter (700-gallon) tanks containing granular activated carbon, and two 3,790-liter (1,000-gallon) post-filtration holding tanks. The granular activated carbon tanks are housed in a wooden shed 3.7 meters (12 feet) long by 3 meters (10 feet) wide. The other five tanks are in a Quonset-style building. The Liquid Pretreatment System has not been used for its intended purpose (i.e., the collection and treatment of chemically impacted groundwater) and is not radioactively contaminated.

C.2.7.3 Leachate Transfer Line

The Leachate Transfer Line, which—based on its function—could be called the Leachate and Interceptor Trench Line, is a 5.1-centimeter-diameter (2-inch-diameter) black polyvinyl chloride (PVC) pipeline that runs along the northeast and northwest sides of the NDA, continues northward across WMA 6, and terminates at Lagoon 2 in WMA 2. The line converts from PVC to galvanized steel east of the Equalization Basin. The transfer line was originally used to transfer liquids from the SDA lagoons via a pumphouse next to the NDA Hardstand to Lagoon 1. The total length of the line is 1,220 meters (4,000 feet). It is radiologically contaminated and may be chemically contaminated.

The section of the Leachate Transfer Line from the SDA to the Interceptor Trench sump is inactive, and the two ends are capped. The section of line from the northeast corner of the NDA to Lagoon 2 is currently used to transfer groundwater from the NDA Interceptor Trench sump.

C.2.7.4 Former NRC-Licensed Disposal Area Lagoon

A lagoon used for collecting surface water runoff was located in the northeastern portion of the NDA. Around 1972, it was filled with radiologically contaminated soil from cleanup after a HEPA filter was dropped at the NDA during disposal operations. The lagoon could have contributed to surface runoff contamination, but other nearby disposal holes and shallow disturbed soils within the disposal area could have contributed as well.

C.2.8 Waste Management Area 8: State-Licensed Disposal Area and Associated Facilities

Facilities in WMA 8, shown on **Figure C-9**, include the North Disposal Area, the South Disposal Area, the Mixed Waste Storage Facility, and three filled lagoons. The SDA is approximately 6.1 hectares (15 acres) in size and is covered with an impermeable geomembrane to prevent infiltration of precipitation.

From 1963 to 1975, approximately 68,000 cubic meters (2.4 million cubic feet) of wastes were received at the SDA for burial from special purpose reactors, commercial power reactors, nuclear fuel cycle facilities, institutions, isotope production, and industries. The wastes were disposed of in their shipping containers including 18.9-liter (5-gallon) steel drums, 114-liter (30-gallon) steel drums, 208-liter (55-gallon) steel drums, wooden crates, cardboard boxes, fiber drums, and plastic bags. Leachate is known to exist in the disposal holes and trenches; up to 7.9 million liters (2.1 million gallons) are estimated to be present. It consists of infiltration water contaminated with both radiological and hazardous chemical materials leached from the buried wastes.

Efforts to manage infiltration were undertaken to stem accumulation of water in the trenches following cessation of disposal operations. Initially, the northern trenches (1 through 5) were capped with a single, minimum 1.2-meter (4-foot) lift of silty till soil. Based on experience gained from the initial trenching and capping activities, each southern trench (8 through 14) was capped with a single, minimum 2.4-meter (8-foot) lift of silty clay soil. The compaction of the silty clay trench caps was performed using multiple passes by a bulldozer over each cap. In 1978, an additional 1.2-meter (4-foot) lift of silty clay soil was placed and compacted upon each individual northern trench to minimize the infiltration of water. In 1980, the caps associated with Trenches 11 through 14 were addressed in a corrective action plan. This plan detailed the removal of 0.6 meters (2 feet) of silty till and 0.15 meters (0.5 feet) of topsoil followed by replacement with 0.7 meters (2.3 feet) of compacted till and 0.3 meters (1 foot) of topsoil, which was then graded, seeded, and mulched. In response to increasing leachate levels in Trench 14, a concrete barrier was installed upgradient of this trench. The barrier wall was 1.2 meters (4 feet) thick and 40 meters (130 feet) long, and the depth was variable. After installation, sand and gravel west of this barrier was removed and replaced with compacted silt and clay from WNYNSC.

As leachate levels continued to increase within Trenches 13 and 14, New York State Energy Research and Development Authority (NYSERDA) planned a series of interim measures that included the subsurface installation of an upgradient vertical barrier (i.e., slurry wall) followed by the placement of a low-density polyethylene membrane cover to divert precipitation. In September 1992, NYSERDA installed a soil-bentonite slurry wall along the western side of Trench 14 to divert groundwater flow away from the southern trenches (8 through 14). The membrane cover, which extended from the centerline of Trench 12 across Trenches 13 and 14, was completed in June 1993. These barriers have effectively minimized the infiltration of groundwater and precipitation into Trenches 13 and 14. In September 1993, NYSERDA installed a bioengineered cover on Trench 9 as a pilot test. This cover was composed of an impermeable ground cover (i.e., fiberglass panels) over most of the trench in combination with junipers. The fiberglass panels provided for minimal infiltration of precipitation, and the junipers provided for a high rate of evapotranspiration. Upon evaluation of the leachate levels, soil moisture data, and vegetative data, it was determined that a low-density polyethylene geomembrane cover would provide comparable control of infiltration. In 1995, NYSERDA installed a reinforced geomembrane cover over Trenches 1 through 8, 10, 11, and the remainder of 12. A stormwater management system consisting of five reinforced geomembrane-lined stormwater basins was designed and installed to detain precipitation and release it in a controlled manner that would not increase peak runoff. The geomembrane has effectively minimized the infiltration of precipitation into these trenches. In the fall of 1999, an additional low-density polyethylene membrane cover was placed over Trench 9, completing the interim measure to limit infiltration into the SDA trenches.

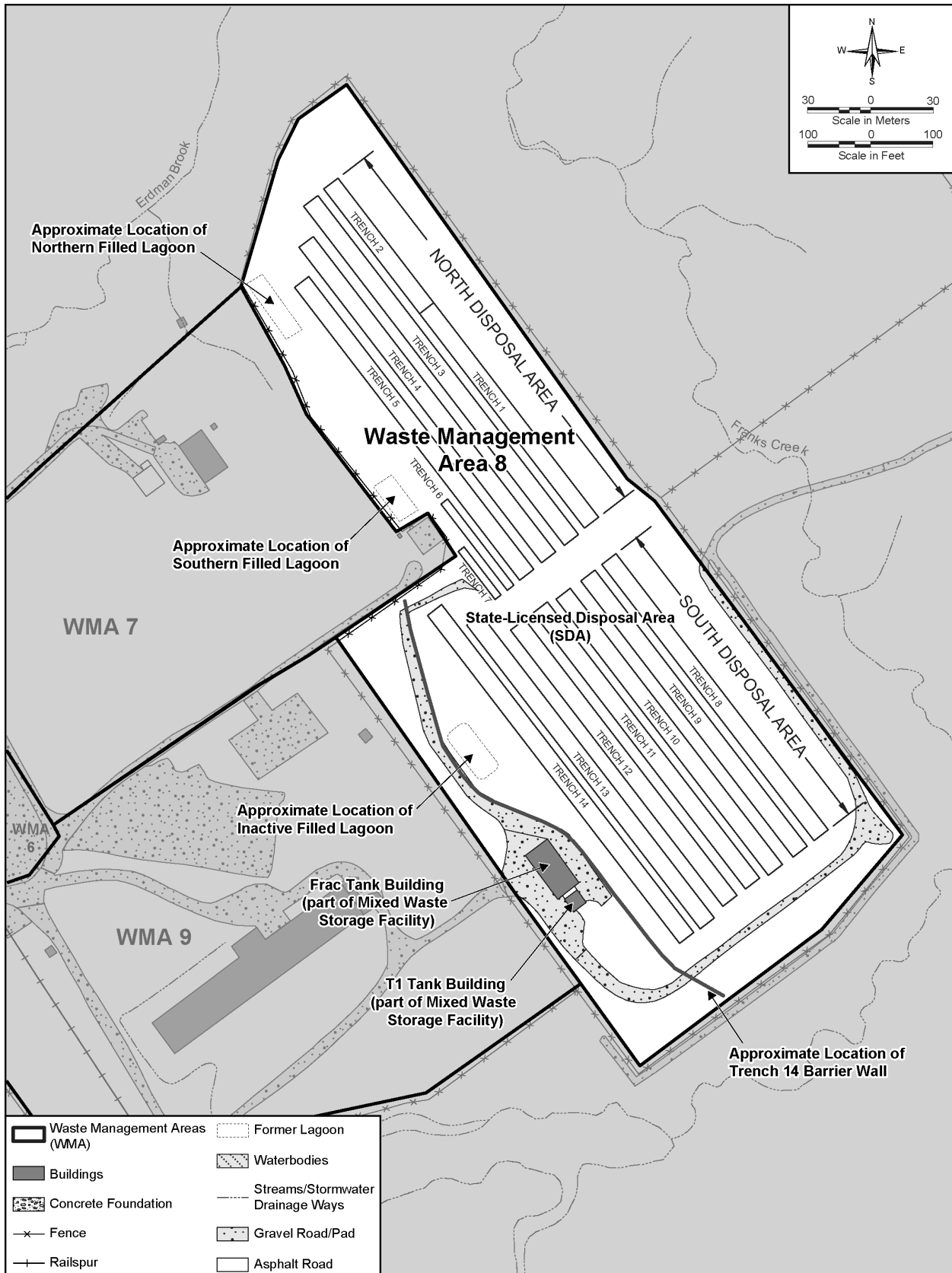

Figure C-9 Waste Management Area 8 – State-Licensed Disposal Area and Associated Facilities

The disposal areas and filled lagoons are identified as SWMUs subject to corrective action requirements pursuant to the RCRA 3008(h) Consent Order. A Corrective Measures Study is being prepared. The Mixed Waste Storage Facility is a RCRA interim status unit and is subject to RCRA closure.

C.2.8.1 Disposal Areas

North Disposal Area

The North Disposal Area includes Trenches 1 through 7. Trenches 1 through 5 were about 10.7 meters (35 feet) across and were excavated to a depth of 6.1 meters (20 feet). These trenches were used to dispose of solid wastes having contact surface readings of 200 millirad per hour or less. The wastes were disposed of in the same packages that were used to contain and transport them.

Trench 6 is actually a series of 19 special purpose holes that were used to dispose of wastes having contact surface readings of more than 200 millirad per hour. These holes were 0.6 to 1.8 meters (2 to 6 feet) wide, 1.2 to 3.6 meters (4 to 12 feet) long, and 2.4 to 3.6 meters (8 to 12 feet) deep. The wastes disposed of in these holes consisted primarily of irradiated reactor parts.

Trench 7 consists of a concrete slab with wastes placed on top of the slab and concrete poured over the wastes to encase them. The wastes were similar to those placed in Trenches 1 through 5.

The unweathered till below Trenches 4 and 5 is contaminated with tritium to a depth of 3 meters (10 feet) and other radionuclides to a depth of 0.9 meters (3 feet) or less (Prudic 1986). It is assumed that Trenches 1, 2, and 3 in the North Disposal Area exhibit a similar vertical contamination profile. The waste inventory in the North Disposal Area trenches, based on available burial records, consists of approximately 26,400 cubic meters (932,000 cubic feet) (URS 2002).

South Disposal Area

The South Disposal Area includes Trenches 8 through 14. These trenches were about 10.7 meters (35 feet) across and were excavated to a depth of about 6.1 meters (20 feet). They were used to dispose of solid wastes having contact surface readings of 200 millirad per hour or less. The wastes were disposed of in the same packages that were used to contain and transport them.

Unweathered till below Trench 8 is contaminated with tritium to a depth of 3 meters (10 feet) and other radionuclides to a depth of 0.9 meters (3 feet) or less (Prudic 1986). It is assumed that the other trenches in the South Disposal Area exhibit a similar vertical contamination profile.

The waste inventory in the South Disposal Area trenches, based on available burial records, consists of 40,500 cubic meters (1,430,000 cubic feet) (URS 2002).

Radionuclide and Chemical Inventories in the Entire State-Licensed Disposal Area

The estimated radionuclide inventory of the buried waste at the North and South Disposal Areas of the SDA at the starting point of this EIS is provided in **Table C-12**.

Table C–12 Estimated Radionuclide Inventory of the Buried Waste at the State-Licensed Disposal Area

<i>Radionuclide</i>	<i>Estimate^a (curies)</i>	<i>Radionuclide</i>	<i>Estimate^a (curies)</i>
Tritium	22,300	Uranium-235	3.53
Carbon-14	306	Uranium-238	192
Cobalt-60	1,250	Neptunium-237	0.00165
Nickel-63	19,100	Plutonium-238	24,300
Strontium-90	135	Plutonium-239	184
Technetium-99	1.49	Plutonium-240	109
Iodine-129	3.32	Plutonium-241	2,290
Cesium-137	11,300	Americium-241	484
Uranium-233	2.46	Radium-226	27.2
Uranium-234	98.3		

^a Decayed to 2011.
Source: URS 2002.

An estimate of the hazardous chemical inventory of the buried waste for the entire SDA was prepared (SAIC 2005b), with emphasis on the chemicals that are important for estimating risk to receptors downgradient of the SDA. **Table C–13** presents the inventories of the organic chemicals and metals.

Table C–13 Estimated Hazardous Chemical Inventory of the Buried Waste at the State-Licensed Disposal Area

<i>Chemical^a</i>	<i>Contamination (kilograms)</i>
Toluene	2,500
Xylene	170
Arsenic	650
Cadmium	90
1,1-dichloroethane	20
1,4-dioxane	5,900
2-chlorophenol	72
2,4-dichlorophenol	91
Benzene	41
Chloroform	13
Cresol (3&4-methylphenol)	90
Methylene chloride	100

^a Additional chemical contaminants were identified but are not listed in this table because they would add relatively small contributions to the risk to downgradient receptors.
Note: To convert kilograms to pounds, multiply by 2.2046.
Source: SAIC 2005b.

Below-Grade Walls

A subsurface concrete wall was installed during 1987 immediately west of Trench 14. The concrete wall supported NYSEERDA's efforts to remove the sand and gravel unit adjacent to Trench 14 and replace it with compacted till. It is a minimum of 1.2 meters (4 feet) thick and 39.6 meters (130 feet) long and contains approximately 320 cubic meters (11,300 cubic feet) of concrete.

A slurry wall located along the west side of Trench 14 was installed during 1992 to control groundwater infiltration into the SDA. It is 9.1 meters (30 feet) deep, 0.76 meters (2.5 feet) wide and

259 meters (850 feet) long; it was made from a mixture of native clay and at least one percent bentonite clay. No radioactive or hazardous chemical contamination of the slurry wall is expected.

C.2.8.2 Mixed Waste Storage Facility

The Mixed Waste Storage Facility consisting of two aboveground buildings near the southern end of the SDA, houses four leachate storage tanks. These structures, the T-1 Tank Building and the Frac Tank Building, are also used to store some solid, radioactive, and potentially mixed low-level radioactive wastes. Residual radioactive and chemical contamination are expected to be found in this facility.

The T-1 Tank Building is the smaller of the two buildings. It is a heated, weatherproof building that houses Tank T-1, a 34,800-liter (9,200-gallon) leachate collection tank made of fiberglass-reinforced plastic. The lower portion of the building is built of concrete to provide secondary containment for a tank that was used to store approximately 28,400 liters (7,500 gallons) of untreated leachate that was pumped from Trench 14 during 1991.

The Frac Tank Building is the larger of the two buildings. It is a nonheated, weatherproof building that houses two 79,500-liter (21,000-gallon) stainless steel frac tanks, T-2 and T-3. The tanks are installed in a steel-supported synthetic berm. These tanks have never been used; they were built to provide contingency storage capacity for SDA leachate.

C.2.8.3 Filled Lagoons

A total of three lagoons were built in the SDA and all three have since been filled. The Northern Lagoon and Southern Lagoon were associated with the North Disposal Area. The third lagoon, called the Inactive Lagoon, was associated with the South Disposal Area. Based on samples collected and analyzed as part of the RCRA facility investigation, these three lagoons contain RCRA hazardous constituents, including, but not limited to, benzene, ethylbenzene, toluene, and xylene. All were found to be below NYSDEC recommended cleanup goals (Ecology and Environment 1994); however, a Corrective Measures Study is being prepared.

The Northern Lagoon is 10.7 meters (35 feet) wide and 31.7 meters (104 feet) long, is unlined, and was used to store water pumped from the North Disposal Area trenches. The accumulated water was either treated or discharged, depending on its chemical and radiological characteristics. During 1971, it was connected by a pipeline to the Low-Level Waste Treatment Facility in WMA 2. The unweathered till beneath the lagoon is radiologically contaminated.

The Southern Lagoon is also unlined. It was used to store water pumped from the North Disposal Area trenches and from the NDA Hardstand. The accumulated water was either treated or discharged, depending on its chemical and radiological characteristics. During 1971, it was also connected by a pipeline to the Low-Level Waste Treatment Facility in WMA 2. About 170 cubic meters (6,000 cubic feet) of weathered till beneath the Southern Lagoon became contaminated with tritium. The unweathered till beneath the Southern Lagoon is also believed to be radiologically contaminated from past operations.

The Inactive Lagoon is located approximately 15.2 meters (50 feet) west of Trench 14. The unweathered till beneath the Inactive Lagoon is believed to be radiologically contaminated from past operations.

The Inactive Lagoon was closed by removing liquids and installing a vinyl liner. Native till soil was placed above the vinyl liner and compacted, followed by a cap layer of compacted clay till. The Northern and Southern Lagoons were closed by removing accumulated liquids and placing adsorbent material and compacted native soil over the contaminated soil.

C.2.9 Waste Management Area 9: Radwaste Treatment System Drum Cell

WMA 9, shown on **Figure C–10**, includes 5 hectares (12.4 acres) on the South Plateau adjacent to the NDA and SDA. The Drum Cell is the primary facility in WMA 9; it will be standing at the starting point of this EIS. WMA 9 includes the Subcontractor Maintenance Area and the NDA Trench Soil Container Area.

The Drum Cell was built during 1986 and 1987 (Landau et al. 1989) to receive and store radioactive waste solidified in cement and packaged in square 270-liter (71-gallon) drums. The drums of the cement-solidified waste were removed in 2007 and shipped to offsite low-level radioactive waste facilities. The Drum Cell is enclosed by a temporary weather structure, which is a pre-engineered metal building 114 meters (375 feet) long, 18.3 meters (60 feet) wide, and 7.9 meters (26 feet) high. The facility consists of a base pad, shield walls, remote waste handling equipment, container storage areas, and a Control Room within the weather structure. The shield walls at the Drum Cell perimeter are 4.6 meters (15 feet) high and 51 centimeters (20 inches) thick. The base pad consists of concrete blocks set on a layer of compacted crushed stone, underlain by geotextile fabric and compacted clay, which is designed to enhance water drainage. Concrete curbs to support the drum stacks are on top of the base pad. The Drum Cell can hold up to 21,000 drums but is currently empty and is not expected to be contaminated. The Drum Cell is identified as a SWMU; however, it has been determined that no further action is required.

The Subcontractor Maintenance Area is an area that is approximately 6 meters (20 feet) wide by 9 meters (30 feet) long, located on the South Plateau portion of WVDP. The area is flat, covered with compacted stone, and is adjacent to a paved highway. Prior to 1991, a WVDP construction contractor had used this area to clean asphalt paving equipment by spraying the equipment with diesel fuel. During this operation, some of the diesel fuel and asphalt material dripped off the equipment and fell onto the ground surface. Following remediation of the area in 1991, it has been used as a staging area for heavy equipment and inert construction materials, including stone and gravel. The Subcontractor Maintenance Area is identified as a SWMU; however, it has been determined that no further action is required.

The NDA Trench Soil Container Pad is a crushed stone pad approximately 46 meters (150 feet) by 92 meters (300 feet) in size and 30 centimeters (12 inches) in thickness. This pad was used to store roll-off containers full of soil excavated from the NDA Interceptor construction. At the starting point of this EIS, the Trench Soil Container Pad will be left in place. The pad is expected to be slightly radiologically contaminated due to past operations.

C.2.10 Waste Management Area 10: Support and Services Area

WMA 10, the Support and Services Area, is shown on **Figure C–11**. WMA 10 encompasses approximately 12.3 hectares (30 acres) extending from the North Plateau to the South Plateau. Facilities in WMA 10 subject to decommissioning include the New Warehouse, Meteorological Tower, and Security Gatehouse and fences. Parking lots located in WMA 10 are discussed in Section C.2.12.2.

At the starting point of this EIS, the Administration Building, Expanded Environmental Laboratory, Construction Fabrication Shop, and Vitrification Diesel Fuel Oil Storage Tank and Building will have been removed to grade. The disposition of the remaining concrete foundations and slabs is analyzed in this EIS.

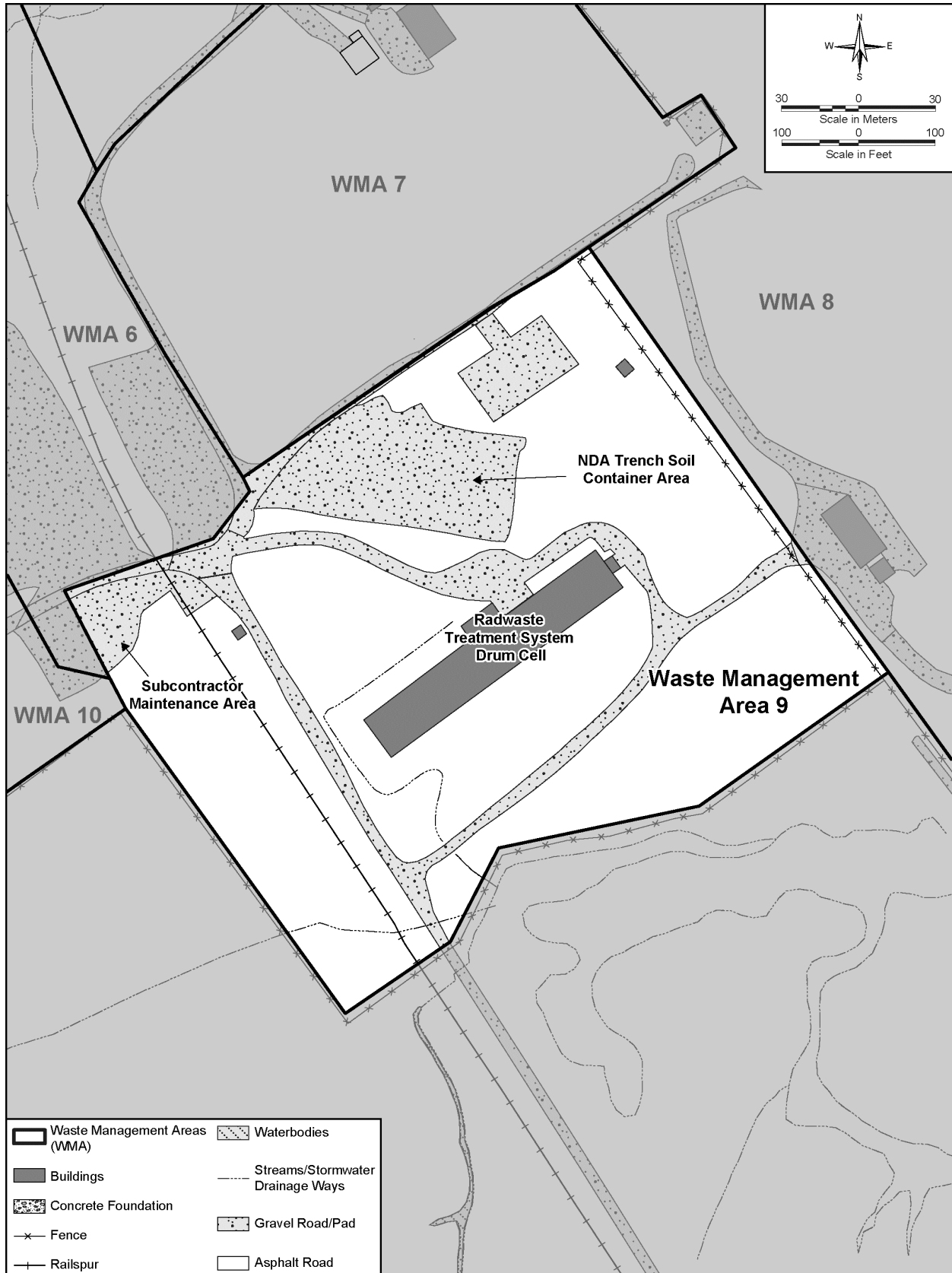

Figure C-10 Waste Management Area 9 – Radwaste Treatment System Drum Cell

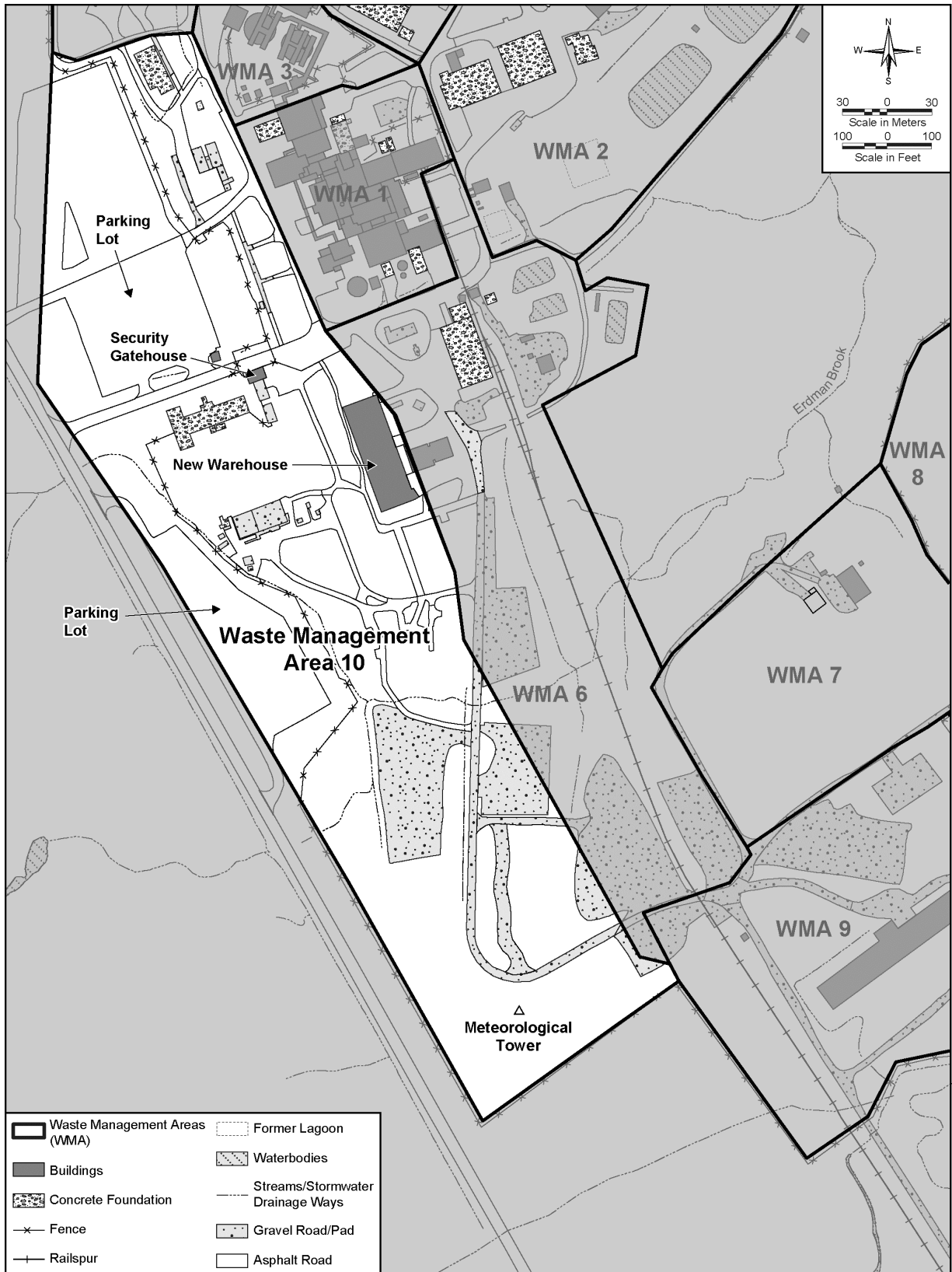

Figure C-11 Waste Management Area 10 – Support and Services Area

C.2.10.1 New Warehouse

The New Warehouse was built during the 1980s and is located east of the Administration Building. It is a pre-engineered steel building that is 24.4 meters (80 feet) wide, 76.2 meters (250 feet) long, and 6.6 meters (21.5 feet) high at the roof peak, resting on about 40 concrete piers and a poured concrete foundation wall. The concrete piers are 0.76 meters (2.5 feet) square and 0.9 meters (3 feet) high; they rest on concrete footings that are 1.5 meters (5 feet) square and 0.4 meters (1.3 feet) thick. The concrete floor is underlain with a gravel base. The average thickness of the concrete floor is 15.2 centimeters (6 inches). The foundation wall is 20.3 centimeters (8 inches) wide and 1.8 meters (6 feet) high. A concrete block firewall divides the warehouse into two sections, separating the Former Waste Management Staging Area from the general storage/warehouse section.

C.2.10.2 Meteorological Tower

The Meteorological Tower is located at the south end of WMA 10. It is constructed from steel, is approximately 60.9 meters (200 feet) high, and is supported by a concrete foundation. It has three 3.3-centimeter-diameter (1.25-inch-diameter) main support columns with interior trusses. It is anchored down at three deadman locations with five support cables attached to each deadman. Monitoring equipment is located on the tower at 9.7 meters (32 feet), 60.4 meters (198 feet), and 60.9 meters (200 feet) above the ground. A standby generator and electrical boxes rest on a concrete pad that is 1.5 meters (5 feet) wide, 1.8 meters (6 feet) long, and 15.2 centimeters (6 inches) thick.

C.2.10.3 Security Gatehouse and Fences

The Main Security Gatehouse is located adjacent to the Administration Building. This gatehouse was constructed when the Main Plant Process Building was built in 1963. During the early 1980s, the Main Gatehouse was renovated, and a large addition was added. The gatehouse is 10.4 meters (34 feet) long, 6.1 meters (20 feet) wide, and 2.7 meters (9 feet) high at the edge of the roof. Construction materials include a concrete foundation, concrete block walls, a concrete slab floor that is 15.2 centimeters (6 inches) thick, and a built-up roof with metal deck.

A barbed-wire security fence runs along the perimeter of the WNYNSC property line. This fence consists of three strands of barbed wire supported by metal posts; the posts are spaced 6.1 meters (20 feet) apart. The fencing has a total running length of approximately 38,100 meters (125,000 linear feet).

A steel security fence surrounds WVDP, the SDA, and miscellaneous other locations. It is made of galvanized chain link with galvanized steel pipe posts spaced 3 meters (10 feet) apart. The fence is 2.1 meters (7 feet) high with a total length of 7,620 meters (25,000 feet). Three strands of barbed wire are stretched across the top of the fence. The posts are set in concrete footings that are 15.2 centimeters (6 inches) in diameter and 1.5 meters (5 feet) deep.

C.2.11 Waste Management Area 11: Bulk Storage Warehouse and Hydrofracture Test Well Area

WMA 11, located in the southeast corner of WNYNSC outside the Project Premises and the SDA, is shown on **Figure C-12**. The only facility in this WMA analyzed in this EIS is the Scrap Material Landfill. The Bulk Storage Warehouse and the Hydrofracture Test Well Area will be decommissioned before the starting point of this EIS.

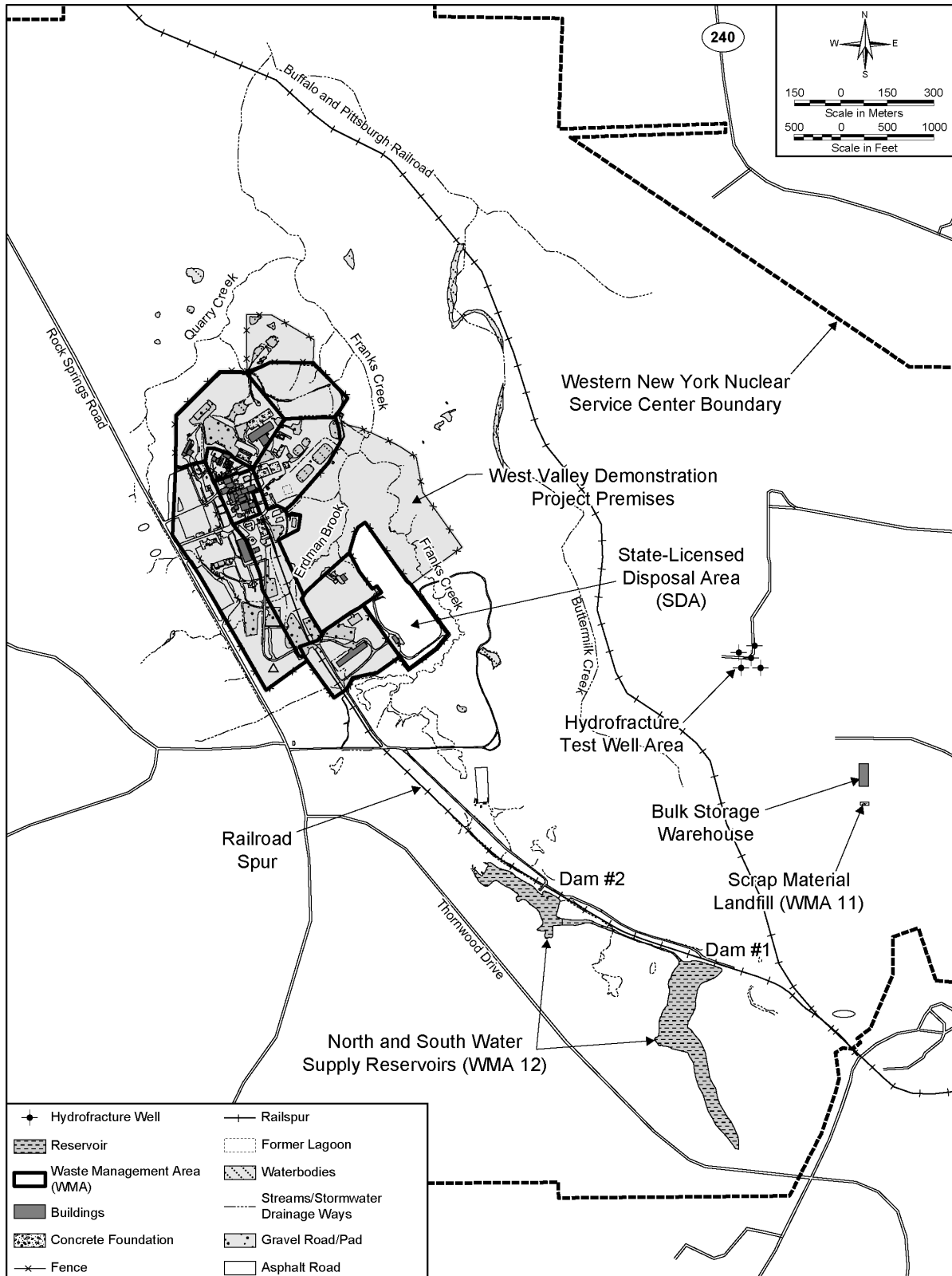

Figure C-12 Waste Management Areas 11 and 12 – Bulk Storage Warehouse and Hydrofracture Test Well Area (Waste Management Area 11) and also Balance of Site (Waste Management Area 12)

The Scrap Material Landfill is located approximately 30 meters (100 feet) south of the Bulk Storage Warehouse. The surface expression of the Scrap Material Landfill is a noticeable low mound that rises 1.2 to 1.5 meters (4 to 5 feet) above the surrounding natural grade. During 1982, NYSERDA removed scrap equipment, consisting of an aluminum transfer hood and 326 empty steel and concrete containers, from the Bulk Storage Warehouse and buried them in a 3-meter-wide (10-foot-wide), 36.6-meter-long (120-foot-long), 4.3-meter-deep (14-foot-deep) trench in the Scrap Material Landfill. This waste material was radiologically surveyed; decontaminated, as necessary; and released for unrestricted use before it was buried in the trench. No radioactive or hazardous waste was buried in the Scrap Material Landfill. The trench was backfilled with soil and capped with a 12.2-meter-wide (40-foot-wide), 39.6-meter-long (130-foot-long), 1.5-meter-high (5-foot-high) soil cover. Two concrete markers identify the ends of the burial trench. The Scrap Material Landfill is identified as a SWMU; however, it has been determined that no further action is required.

C.2.12 Waste Management Area 12: Balance of Site

WMA 12, Balance of Site, is shown on Figure C-12. Facilities analyzed in this EIS consist of the two earthen dams and reservoirs, parking lots (actually located in WMA 10), and miscellaneous (roped-off) areas of surface contamination (located throughout the Project Premises). WMA 12 also includes Buttermilk Creek, Erdman Brook, and Franks Creek, some of which contain radiologically contaminated sediments resulting from regulated releases of treated process wastewater from the Low-Level Waste Treatment Facility by way of Lagoon 3.

C.2.12.1 Dams and Reservoirs

The two water supply reservoirs, the South Reservoir and the North Reservoir, were constructed during 1963 about 2.4 kilometers (1.5 miles) southeast of the Main Plant Process Building. The South Reservoir has an earthen dam that is 23 meters (75 feet) high with pilings to prevent seepage. The South Reservoir drains through a short canal to the North Reservoir. The North Reservoir has an earthen dam that is 15.2 meters (50 feet) high. It also has a control structure and pumphouse to regulate water level. This reservoir drains into Buttermilk Creek.

The control structure has reinforced concrete walls that are 38.1 centimeters (15 inches) thick and an 88.9-centimeter-thick (35-inch-thick) concrete slab floor supported by pilings. Two pumps in the control building discharge into a 20-centimeter (8-inch) cast iron line that directs water to a storage tank near the Main Plant Process Building. The pumphouse has a 20-centimeter-thick (8-inch-thick) floor. The outflow barrel is a 91.4-centimeter (36-inch) corrugated metal pipe.

C.2.12.2 Parking Lots and Roadways

Two parking lots are located off Rock Springs Road in WMA 10. They are designated as the Main Parking Lot and the South Parking Lot.

The original Main Parking Lot was constructed during the mid-1960s. Two extensions were added during the 1980s. It has a total paved surface area of 16,700 square meters (180,000 square feet). The south driveway into the lot is 7.3 meters (24 feet) wide and 64.6 meters (212 feet) long. The north driveway is 7.3 meters (24 feet) wide and 69.5 meters (228 feet) long. Two aluminum utility poles, 15–25 centimeters (6–10 inches) in diameter and 9 meters (30 feet) tall, rest on concrete foundations that are 0.6 meters (2 feet) square and 0.8 meters (2.5 feet) thick. Six wooden utility poles, 30.5 centimeters (12 inches) in diameter and 9 meters (30 feet) tall, are also there.

The South Parking Lot is an irregularly shaped area constructed during 1991. It has approximately 7,430 square meters (80,000 square feet) of parking area and approximately 595 square meters (6,400 square

feet) of driveways; both are covered with 20.3 centimeters (8 inches) of asphalt. A guardrail approximately 366 meters (1,200 feet) long borders the lot along its southern, eastern, and western sides. The guardrail is one rail high with 120 posts. Eight wooden poles run through the western side of the lot. Each pole is approximately 9.1 meters (30 feet) high.

Roadways are constructed of a stone sub-base that is approximately 20.3 centimeters (8 inches) thick, covered with asphalt that is approximately 10.2 centimeters (4 inches) thick. The total area of pavement is approximately 120,000 square meters (1,300,000 square feet). Although paved roadways are located in most of the designated WMAs, they are addressed here collectively for convenience.

C.2.12.3 Railroad Spur

The Railroad Spur runs from the Fuel Receiving and Storage Building to a rail line junction, northeast of Riceville Station. It serviced the Project Premises site. The portion of the spur within WMA 12 is south of the Project Premises.

C.2.12.4 Soils and Stream Sediments

Available radiological sampling and survey data provide information to estimate areas of surface soil contamination. Additional data from subsequent characterization programs will supplement the currently available information.

Contaminated stream sediments in WMA 12 include sediments in Erdman Brook and in Franks Creek between the Lagoon 3 outfall and the confluence of Franks Creek and Quarry Creek inside the Project Premises fence.

C.2.12.5 Other Potentially Contaminated Areas

Several other areas (“roped-off areas”) are known or believed to contain radiological contamination. These areas consist of the Lag Storage Area 2 Hardstand, a limited area adjacent to Lag Storage Area 3, an overgrown area south of the Solvent Dike, an area east of Lagoons 2 and 3, the railroad track area by the old warehouse, the old Sewage Treatment Plant ditch south of the old warehouse, and several areas near but outside the NDA.

C.2.13 North Plateau Groundwater Plume

Groundwater in portions of the sand and gravel unit in the North Plateau of WNYNSC is radiologically contaminated as a result of past NFS operations. The most significant area of groundwater contamination is associated with the North Plateau Groundwater Plume, which extends from WMA 1 into WMAs 2 through 6, as shown on **Figure C–13**. The plume boundary shown on Figure C–13 represents the boundary of the 10-picocuries-per-liter gross beta concentration in groundwater, as found in 2007. The plume discharges from groundwater to surface water in WMA 4. This contaminated surface water then flows from WMA 4 to WMA 12 to Cattaraugus Creek, where it leaves WNYNSC.

The North Plateau Groundwater Plume is a 200-meter-wide (650-foot-wide) by 500-meter-long (1,640-foot-long) zone of groundwater contamination that extends northeastward from the Main Plant Process Building in WMA 1 to the CDDL in WMA 4. Strontium-90 is the principal radionuclide in this plume, with it and its daughter radionuclide, yttrium-90, contributing equal amounts of beta activity. An estimate of the amount of residual radioactivity present in the North Plateau Groundwater Plume at the start of the decommissioning is given in **Table C–14**.

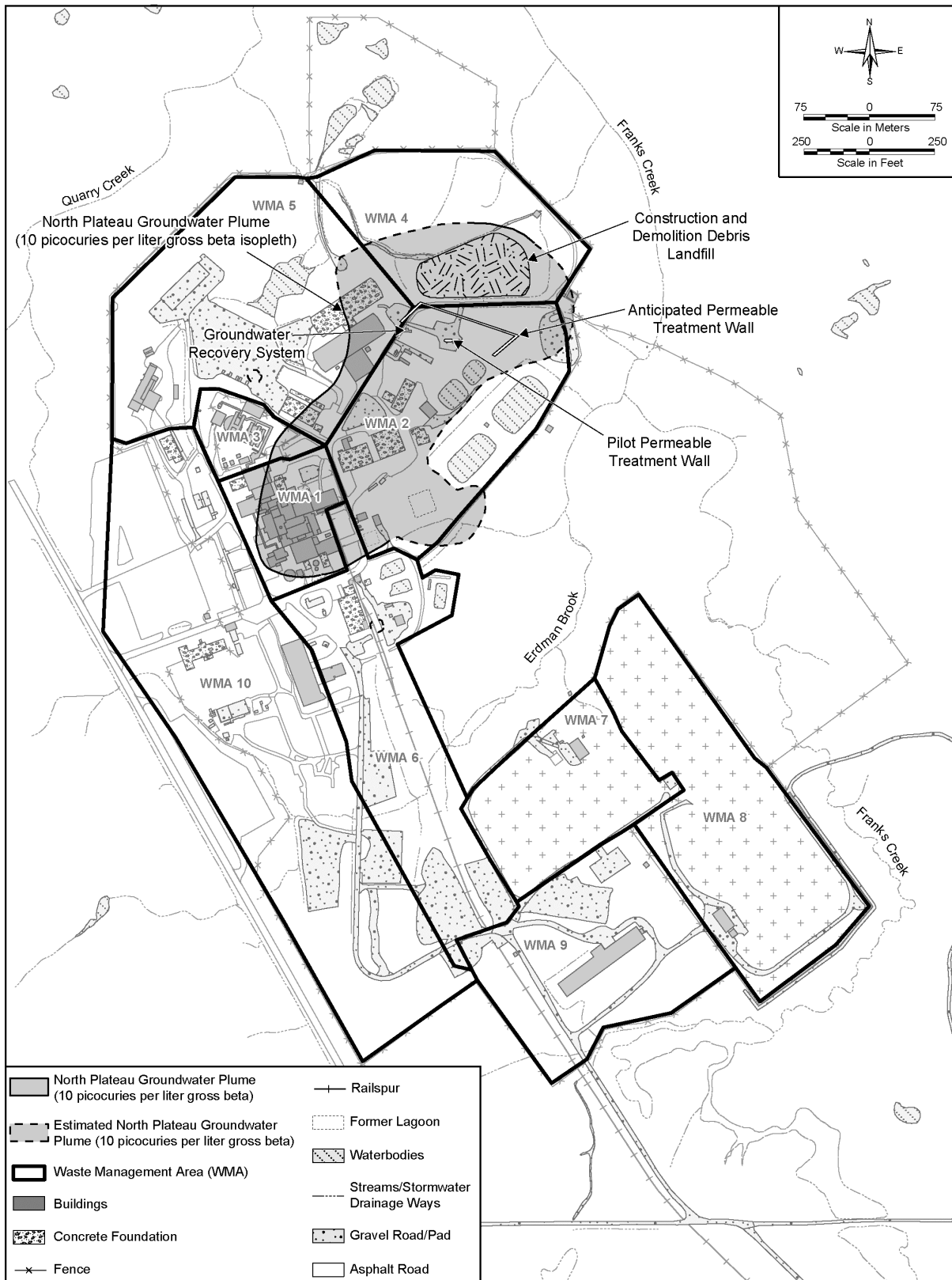

Figure C-13 North Plateau Groundwater Plume

Table C–14 Estimated Radionuclide Inventory in the North Plateau Groundwater Plume

<i>Radionuclide</i>	<i>Estimate^a (curies)</i>	<i>Radionuclide</i>	<i>Estimate^a (curies)</i>
Carbon-14	0.00127	Uranium-235	8.89×10^{-7}
Strontium-90	36.7	Uranium-238	7.88×10^{-6}
Yttrium-90	36.7	Neptunium-237	0.00025
Technetium-99	0.015	Plutonium-238	0.051
Iodine-129	1.95×10^{-6}	Plutonium-239	0.016
Cesium-137	39.7	Plutonium-240	0.013
Uranium-233	0.0000688	Plutonium-241	0.253
Uranium-234	0.0000465	Americium-241	0.662

^a Decayed to 2011.

Source: Westcott 1998.

The source of the plume is generally considered to be an acid recovery line that leaked in the southwest corner of the Main Plant Process Building. During the late 1960s, the NFS Acid Recovery System, which was housed in the southwest corner of the Main Plant Process Building, leaked an unknown volume of radioactive nitric acid that contained various radioactive fission products. The leaking acid flowed down the walls of the off-gas cell and the adjacent southwest stairwell and migrated into the sand and gravel unit underlying the Main Plant Process Building through an expansion joint in the floor of the off-gas cell. After entering the sand and gravel unit, the radiologically contaminated acid was able to mix with groundwater. To varying degrees, mobile radionuclides such as tritium, strontium-90, and technetium-99 were able to migrate with the groundwater along the northeast groundwater flow path in the North Plateau. Currently, the highest strontium-90 activities in groundwater are estimated to exist 46 meters (150 feet) downgradient from the original release point under the Main Plant Process Building. Less-mobile radionuclides, such as cesium-137, are expected to have remained beneath the immediate source area because of the high cesium sorptive capacity of the minerals in the sand and gravel unit. The eastern edge of the smaller southeastern lobe shown on Figure C–12 is generally considered to have originated from Lagoon 1.

For the purpose of analysis in this EIS, the North Plateau Groundwater Plume is divided into two areas: the source area directly underneath the Main Plant Process Building and the nonsource area that encompasses the rest of the plume.

C.2.13.1 Groundwater Recovery System

During 1995, a pump and treat system (Groundwater Recovery System) was established in WMA 2 to control the western lobe of the plume. Groundwater is pumped from three wells to the Low-Level Waste Treatment Facility, where strontium-90 is removed by ion-exchange. The treated groundwater is transferred to Lagoons 4 or 5 and then to Lagoon 3, from which it is eventually discharged through an SPDES-regulated discharge point to Erdman Brook. Through calendar year 2007, approximately 186 million liters (49 million gallons) of groundwater had been treated, and approximately 8 curies of strontium-90 had been removed (WVES and URS 2008, WVES 2007). Although the Groundwater Recovery System has been effective in limiting the seepage of impacted groundwater to the ground surface, it has not completely mitigated the advance of the western lobe of the plume (Geomatrix 2007). Further, it has no impact on the eastern lobe of the plume, leading to the consideration of additional technologies and construction of a pilot-scale permeable treatment wall, which is discussed in the following section.

C.2.13.2 Permeable Treatment Walls

During 1999, a pilot-scale permeable treatment wall was installed in WMA 2 within the leading edge of the eastern lobe of the plume to evaluate the effectiveness of this type of system in treating groundwater contaminated with strontium-90. The bottom of the pilot-scale permeable treatment wall is in the Lavery till, and the wall extends above the water table level. The wall is about 9.1 meters (30 feet) wide, 1.8 meters (6 feet) thick, and 8.5 meters (28 feet) deep; it is filled with a natural zeolite ion-exchange material, known as clinoptilolite. A 0.3-meter-thick (1-foot-thick) vertical layer of pea gravel was placed on the upgradient side of the wall to reduce clogging and provide a porous inlet for groundwater to enter the 1.5-meter-thick (5-foot-thick) vertical layer of natural zeolite. Soil was placed over the permeable treatment wall, and it was seeded with vegetation to prevent erosion. As groundwater flows through the permeable treatment wall, the strontium-90 is removed from groundwater onto the natural zeolite by ion-exchange. Wells were installed upgradient of and downgradient from the permeable treatment wall for the purpose of sampling the groundwater to monitor the effectiveness of the permeable wall for capturing strontium-90 in this application. Concentration reductions exceeding three orders of magnitude have been indicated by groundwater monitoring data. While some groundwater passes through the permeable treatment wall, test results indicate that groundwater also flows around the permeable treatment wall due to subsurface heterogeneity in the immediate vicinity.

An evaluation of monitoring data indicates that the permeable treatment wall is effective in removing strontium-90 from groundwater inside the permeable treatment wall through ion-exchange although the pilot system is too short in length to mitigate the advance of strontium-90 in the east lobe. Evaluations also indicate some operational and construction improvements can be made to increase the effectiveness of the technology application at WVDP when applied at full scale. Because the pilot program successfully showed that strontium-90 can be removed in situ using a permeable treatment wall and also provided information on construction and design issues that can be overcome (Geomatrix 2007), this technology is seen as a potential full-scale remedy for managing groundwater affected by strontium-90 at the site. Therefore, a full-scale system that is approximately 150 meters (500 feet) wide, is assumed to be implemented in WMA 2 before the EIS starting point.

C.2.14 Cesium Prong

The Cesium Prong, shown on **Figure C-14**, is the result of emissions of cesium in 1968 that contaminated land inside and outside of the WNYNSC boundary. The primary contaminant is cesium-137.

Studies have shown that contaminant concentrations decrease with depth. Seventy-five percent of the activity is in the upper 5 centimeters (2 inches) of soil, and 20 percent is in the layer between 5 centimeters (2 inches) deep and 10 centimeters (4 inches) deep. In other words, 95 percent of the activity may occur in the upper 10.2 centimeters (4 inches) of soil.

C.3 Decommissioning Activities

This section provides detailed descriptions of the decommissioning activities proposed under each action alternative for each WMA. The descriptions include methods of demolition or closure, proposed area remediation as applicable, and discussions on the type and quantity of waste that is estimated to be generated. The various types of waste that would be potentially generated are defined in Chapter 2, Section 2.1, of this EIS. The section is structured on an alternative basis. Section C.3.1 describes the proposed activities under the Sitewide Removal Alternative; Section C.3.2, the Sitewide Close-In-Place Alternative; and Section C.3.3, Phase 1 of the Phased Decisionmaking Alternative. Summaries of the decommissioning activities are presented in Sections 2.4.1, 2.4.2, and 2.4.3 of this EIS.

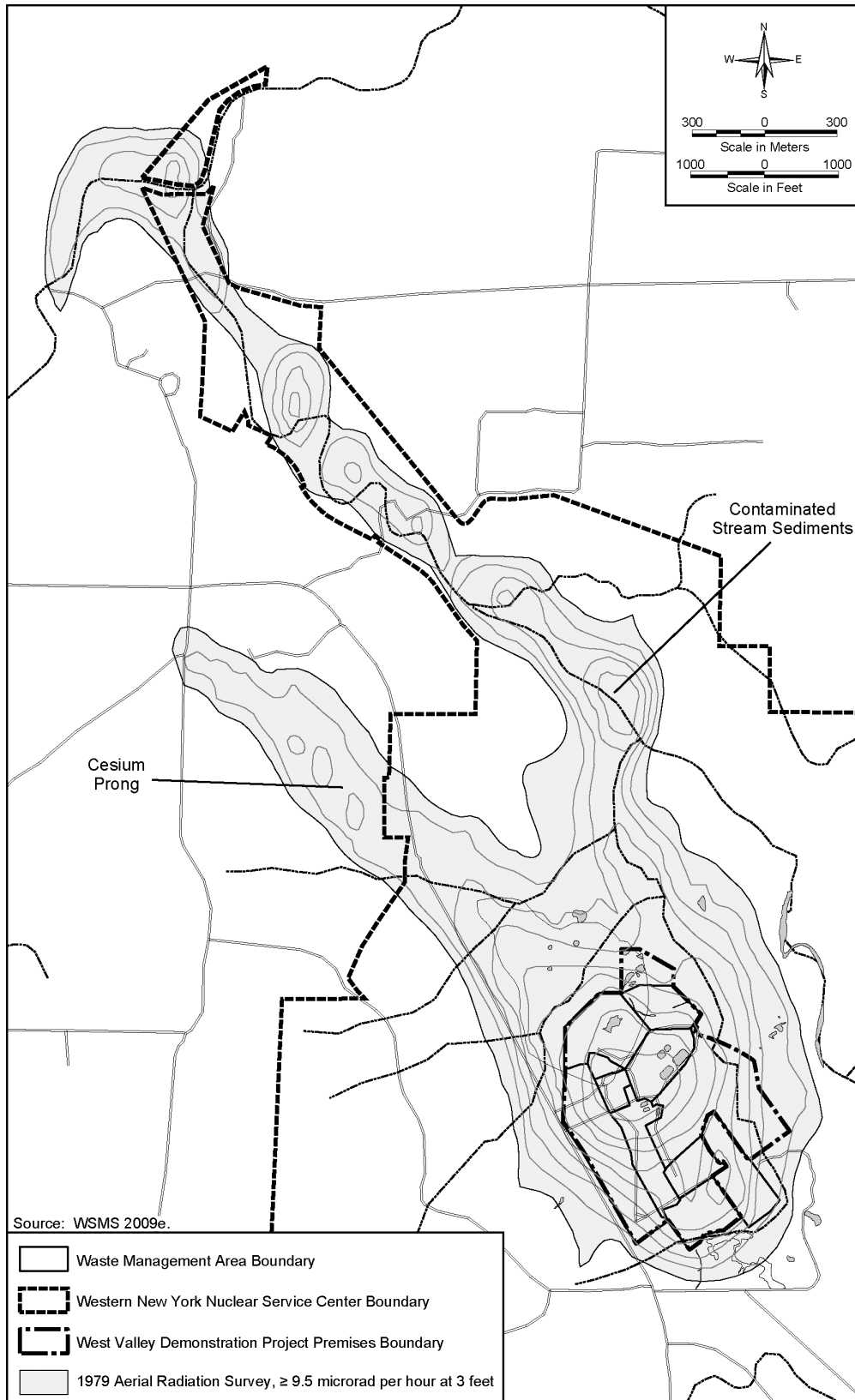

Figure C-14 1979 Aerial Radiation Survey

C.3.1 Sitewide Removal Alternative

Under the Sitewide Removal Alternative, all site facilities would be removed, environmental media would be decontaminated, and all radioactive, hazardous, and mixed low-level radioactive waste would be characterized; packaged, as necessary; and shipped off site for disposal.

This alternative also involves the use of storage facilities to provide for interim storage of orphan waste having no currently permitted disposal site. The new Container Management Facility, which would be constructed primarily for the processing of the waste removed from the NDA and SDA, would be used for this purpose. The Container Management Facility is discussed in Section C.4.4.

Unless otherwise noted, information presented in Section C.3.1 is from the *Sitewide Removal Alternative Technical Report* (WSMS 2009b).

C.3.1.1 Waste Management Area 1: Main Plant Process Building and Vitrification Facility Area

Under the Sitewide Removal Alternative, the high-level radioactive waste canisters stored in the Main Plant Process Building would be relocated. All facilities, including underground structures and remaining floor slabs and foundations, would be removed, including the Main Plant Process Building; Vitrification Facility; 01-14 Building; Load-In/Load-Out Facility; Utility Room and Utility Room Expansion; Plant Office Building; Fire Pumphouse and Storage Tank; Electrical Substation; Off-Gas Trench; underground tanks (7D-13, 15D-6, 35104); and underground process, wastewater, and utility lines. The source area of the North Plateau Groundwater Plume would also be removed.

C.3.1.1.1 Relocation of the High-Level Radioactive Waste Canisters

Preparations to move the vitrified high-level radioactive waste canisters from the Main Plant Process Building to the new onsite Interim Storage Facility (Dry Cask Storage Area) would include modifying the Equipment Decontamination Room to handle the high-level radioactive waste canisters; modifying the Load-In/Load-Out Facility for this purpose, that is, converting it into a Load-Out Facility; and establishing the new Interim Storage Facility (Dry Cask Storage Area), which would be located on the South Plateau near the Rail Spur. The new onsite Interim Storage Facility (Dry Cask Storage Area) to be constructed is discussed in Section C.4.1.

Modifications to the Equipment Decontamination Room would include installation of new equipment such as a crane to remove the canisters from the transfer cart and to position them for transfer into the Load-Out Facility, along with a storage rack and a canister tilting fixture to be used to prepare the canisters for horizontal transfer into the Load-Out Facility. Equipment to weigh the canisters and verify their dimensions would also be installed.

Modifications would also include installation of equipment such as a shielded transfer cell, a canister handling system, and a high-capacity crane. The transfer cell would provide the capability to remotely decontaminate and survey the outside surfaces of the canisters and include features such as a shielded viewing window(s) and a remotely operated manipulator. The cell walls and roof would be constructed of carbon steel to provide radiation shielding. A HEPA-filtered ventilation exhaust system would also be installed. The Load-Out Facility design concept is based on use of a truck-mounted transportation and storage cask that would hold up to seven vitrified high-level radioactive waste canisters.

The new onsite Interim Storage Facility (Dry Cask Storage Area), which would be located in WMA 6, would be patterned on spent nuclear fuel dry storage installations currently licensed by the NRC. It would consist of a

reinforced concrete pad where casks containing the high-level radioactive waste canisters would be temporarily stored inside individual concrete storage modules that would provide radiation shielding and mechanical protection.

After the preparations to move the high-level radioactive waste canisters, including the appropriate readiness reviews, are completed, the canisters would be decontaminated, loaded in their storage casks, and transported to the new Interim Storage Facility (Dry Cask Storage Area). They would remain in this facility until disposition decisions are made and implemented.

C.3.1.1.2 Demolition of the Main Plant Process Building

For demolition purposes, portions of the Main Plant Process Building would be divided into five categories, based upon design, construction, and location: (1) the plant stack and remaining equipment, (2) framework cells, (3) reinforced concrete framework cells, (4) tower cells, and (5) below-grade cells. Demolition of the Main Plant Process Building would also follow this general sequence.

The Main Plant Process Building contains 32 lead glass viewing windows, which together contain approximately 10,000 kilograms (22,000 pounds) of lead in their frames. These viewing windows would be removed before demolition of the building begins, and some portion would likely be managed as hazardous waste.

Removal of the Plant Stack and Remaining Equipment

The plant stack, which is 41 meters (160 feet) tall and 1.4 to 3 meters (4.5 to 10 feet) in diameter and is made of Type 304L stainless steel, is located on the roof of the Main Plant Process Building. It would be removed before demolition of the building itself is started. Because the stack was originally assembled in five sections, to facilitate demolition, it would similarly be removed in sections. The pieces would be lowered to the ground by crane, where they would then be wrapped to prevent the spread of contamination. The pieces would be reduced in size and packaged and would likely be disposed of as Class A low-level radioactive waste.

Prior to demolition, remaining equipment, including piping and vessels, would be removed. Some of this material may be transuranic waste.

Demolition of the Framework Cells

The framework cells were designed and constructed with masonry or concrete walls, floors, and ceilings that are supported by a structural steel framework. The walls of the framework cells are constructed from concrete block. Floors are concrete on steel decking. In demolishing the framework cells, asphalt roofing material, some of which contains asbestos, would be removed first using skid steer loaders and handheld equipment. The debris would be removed and placed in containers for disposal. Asbestos-containing material would be managed separately.

The steel roof decking underlying the asphalt roofing would be removed and reduced in size with a mobile shear attached to a small, track-mounted, electric powered, hydraulic demolition machine. The shear attachment could cut through the roof decking, reduce the size of this material, and place it into boxes.

The masonry and concrete walls in the framework cells would be demolished with a demolition machine equipped with either a demolition hammer operated under a fog spray or shear. The hammer would break through the concrete, and the shear would be used to cut through the steel reinforcement in the concrete, as well as the steel members comprising the skeleton of these cells. A skid steer loader would be used to place rubble into the transfer boxes, which would be lowered to ground level with a crane. The demolition debris is

assumed to be managed as low-specific-activity waste and disposed of off site at a low-level radioactive waste disposal facility.

Demolition of the Reinforced Concrete Framework Cells

The reinforced concrete framework cells were constructed using reinforced high-density concrete up to 1 meter (3 feet) thick to provide radiation shielding while highly radioactive samples were being analyzed within them. These cells are situated within and above the framework cells of the Main Plant Process Building, and they would be demolished in conjunction with those cells.

The reinforced concrete framework cells include Analytical Cells 1 through 5, the Sample Cell, and the Sample Storage Cell, which are located at a plant elevation of 40 meters (131 feet). These cells would be demolished with demolition machines. A skid steer loader would place the demolition debris into transfer boxes, which would be lowered to ground level using a crane. This debris is assumed to be managed as low-specific-activity waste and disposed of off site at a low-level radioactive waste disposal facility.

Demolition of the Tower Cells

The tower cells are constructed entirely of reinforced concrete. Their construction would allow these cells to be free-standing structures if they were physically segregated from other portions of the Main Plant Process Building. The walls, floors, and ceilings of these cells typically consist of either high-density (3,800 kilograms per cubic meter [235 pounds per cubic foot]) or standard density (2,400 kilograms per cubic meter [150 pounds per cubic foot]) reinforced concrete that is up to 1.7 meters (5.5 feet) thick. The tower cells would be demolished in a controlled manner by segmenting the walls and ceilings with diamond-wire saws.

The first step in the demolition of the tower cells would be segmentation and removal of the ceilings. A series of holes would be drilled through the ceiling through which the diamond wire would be passed and to which lifting bales would be attached. The diamond wire would cut through the concrete and any rebar or penetrations. The ceiling segment would be supported from above by a crane that would remove the ceiling segment when cut.

The walls would be segmented in a similar fashion using diamond-wire cutting. The ceiling and wall segments would be sized to fit into waste packages. Conventional demolition equipment would be used to remove the floor slabs once the walls are removed. The demolition debris from the tower cells is assumed to be classified as low-specific-activity waste and would be disposed of off site at a low-level radioactive waste disposal facility.

Demolition of Below-Grade Cells

The demolition of the below-grade cells is addressed in Section C.3.1.1.8 of this EIS with the discussion of the removal of underground structures.

C.3.1.1.3 Demolition of the Vitrification Facility

The Vitrification Facility contains nine lead glass viewing windows having approximately 1,360 kilograms (3,000 pounds) of lead in their frames. These windows would be removed from the building before demolition of the structure and managed separately.

The Vitrification Facility would be demolished to grade level using methods such as those described for the Main Plant Process Building. Considering the construction of the building, the steel frame and sheet metal part of the structure would be demolished first and then the reinforced concrete Vitrification Cell. The thick

reinforced concrete walls and roof components would be segmented, as necessary, using a technique such as diamond-wire cutting. The steel shield doors would also be segmented, as necessary, for disposal.

Demolition waste would be removed from the area and disposed of off site. The debris from the Vitrification Cell would be managed as Class A low-level radioactive waste and the rubble from the rest of the structure as low-specific-activity waste.

Demolition of this building would be coordinated with demolition of the Main Plant Process Building because the two structures are connected.

C.3.1.1.4 Demolition of the 01-14 Building

The 01-14 Building contains a single lead glass viewing window with approximately 225 kilograms (500 pounds) of lead in the frame. This window would be removed from the building before demolition of the structure and managed separately.

In demolishing the structure, the corrugated steel structure would be removed first. It is not expected to be radioactively contaminated, and it is assumed that the materials would be disposed of as construction and demolition debris.

Removal of the concrete building structure would involve use of methods similar to those used with the Main Plant Process Building. It is assumed that the building debris would be handled as low-specific-activity waste.

C.3.1.1.5 Demolition of the Load-Out Facility

The Load-Out Facility (converted from Load-In/Load-Out Facility) would be demolished once all of the high-level radioactive waste canisters have been removed from the Main Plant Process Building. The shielded transfer cell, canister handling system, and high-capacity crane would be dismantled, packaged, and disposed of as Class A low-level radioactive waste at an offsite disposal facility.

A characterization survey would be performed to quantify the contamination and radiation fields in various parts of the building, and a spray fixative would be applied to the interior surfaces of the building. All of the utilities would be isolated. Any equipment remaining in the Load-Out Facility would be removed, including electrical equipment such as generators and pump motors. All the drains and sumps would be sealed.

Standard construction equipment would be used to demolish the Load-Out Facility, as the internal wall surfaces of the structure are not expected to be contaminated. All waste would be characterized, packaged, and disposed of as uncontaminated construction and demolition debris at appropriate offsite disposal facilities.

Using an excavator equipped with a shear, a grapple, and a hammer, the building and slab would be demolished. The equipment and debris would be reduced in size, as necessary, and disposed of off site.

Soils beneath the building and slab would be surveyed to determine if established Derived Concentration Guideline Levels (DCGLs) have been exceeded. Soil with radioactivity concentrations exceeding the DCGLs would be removed. Any contaminated soil would be shipped to an offsite disposal facility as low-level radioactive waste.

The excavation would be backfilled with appropriate clean backfill material.

C.3.1.1.6 Demolition of Other Waste Management Area 1 Facilities

The Utility Room, Utility Room Expansion, Fire Pumphouse, Water Storage Tank, Electrical Substation, and Plant Office Building are relatively simple structures that would be demolished to grade using conventional demolition equipment at an appropriate point in the Main Plant Process Building demolition. The rubble from the Utility Room and Utility Room Expansion would be managed as low-specific-activity waste and the Plant Office rubble as uncontaminated construction and demolition debris.

Equipment and piping in the Fire Pumphouse would be removed and disposed of off site as uncontaminated construction and demolition debris. The pumphouse would be demolished by conventional methods and the rubble managed as uncontaminated construction and demolition debris. The Water Storage Tank would be drained and the water released to the storm sewer in accordance with the existing SPDES permit. The steel tank would be segmented using conventional steel cutting equipment. The tank segments would be disposed of off site as uncontaminated construction and demolition debris.

C.3.1.1.7 Excavation and Hydraulic Barrier Wall Installation

To facilitate removal of the underground structures of the Main Plant Process Building and Vitrification Facility, along with the source area of the North Plateau Groundwater Plume, an area larger than the footprint of both buildings would be excavated. This area is shown on **Figure C-15**.

As can be seen on Figure C-15, the western edge of the excavation would lie near the road in front of the Plant Office Building. Reference should also be made to Figure C-1. The northern edge of the excavation would follow the walkway between the Vitrification Facility and the Waste Tank Farm. The eastern edge would follow the road between the Main Plant Process Building area and the Interceptors. The southern edge would correspond with a line running immediately south of the 01-14 Building, the Utility Room, and the Utility Room Expansion. The footprint of the excavation would comprise approximately 1.2 hectares (3 acres).

To control groundwater, a vertical hydraulic barrier would be installed around the area to be excavated, as shown on Figure C-15. The upgradient portion would be constructed of sheet pile. The downgradient portion would consist of a soil-cement-bentonite slurry wall. Both would extend approximately 0.6 meters (2 feet) into the Lavery till, and the slurry wall would remain in place after the excavation is backfilled.

The total length of the slurry wall would be approximately 230 meters (750 feet), with approximately 160 meters (525 feet) of this length directly adjacent to the WMA 1 area to be excavated. The 160-meter (525-foot) portion of the slurry wall adjacent to the area to be excavated would be 4 meters (13 feet) wide, with the remainder a more typical 0.6 meters (2 feet) wide. The extra width of the main portion of the slurry wall and the inclusion of cement in the mixture would provide the stability necessary to accommodate the nearby excavation.

Construction of the soil-cement-bentonite slurry wall would involve activities such as the following:

- Preparations would be made to handle the approximately 5,600 cubic meters (7,300 cubic yards) of soil to be excavated, 5,000 cubic meters (6,500 cubic yards) of which would be assumed to be radioactively contaminated, with approximately half of that assumed to be saturated.
- A hydraulic excavator would be used to dig the trench for installation of the slurry wall.
- The slurry and backfill mixtures would be prepared in contained areas that would be constructed near the slurry wall.
- During the excavation process, the trench would be kept filled with slurry to help support its walls.

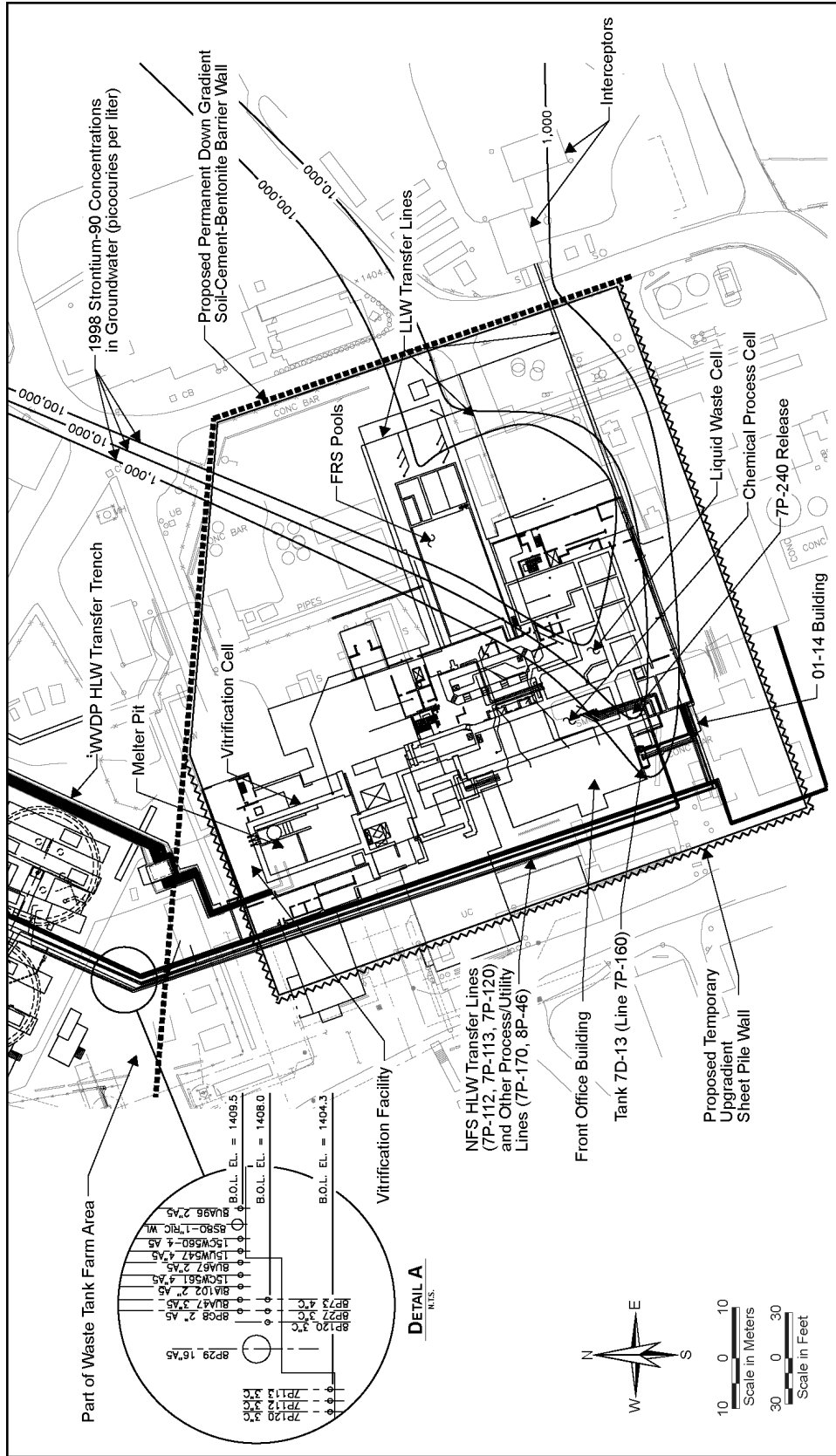

Figure C-15 Conceptual Layout of Waste Management Area 1 Excavation

C.3.1.1.8 Removal of the Plume Source Area, Underground Structures, and Equipment

Removal of the underground structures and equipment would be coordinated with soil removal because the North Plateau Groundwater Plume source area lies beneath the Main Plant Process Building.

Removal of Contaminated Soil and Groundwater

In addition to installation of the hydraulic barrier wall, preparations would include installation of fifteen 15-centimeter-diameter (6-inch-diameter) extraction wells, design and fabrication of a skid-mounted groundwater treatment system, and design and erection of a pre-engineered confinement structure.

The extraction wells would be similar to the extraction wells currently in use in the North Plateau Groundwater Recovery System. This system would include two skid-mounted treatment units having a combined capacity for treating contaminated water of 379 liters (100 gallons) per minute.

The conceptual design of the confinement structure to be used during excavation of the higher-activity materials near the original release is described in Section C.4.6.7. This single-span structure would extend over the portion of the excavation near the release in the southwest corner of the Main Plant Process Building to provide for weather protection and control of airborne radioactivity.

Before excavation would begin, the hydraulic barrier wall would be installed, the groundwater pretreatment system set up, the dewatering wells installed and placed in operation, and the confinement structure installed. The excavation process would be accomplished in two phases using conventional excavation equipment.

The first phase would involve removal of soil in the vadose zone and offsite shipment as low-specific-activity waste. Excavation of soil in the saturated zone would begin after the dewatering wells have removed groundwater in the confined area to the extent practical. The groundwater would be treated using ion-exchange and discharged directly to Erdman Brook through an SPDES-permitted outfall after confirmation that radioactivity concentrations are acceptably low. As the excavation progresses deeper into saturated soils, the excavation crew would construct common sumps to remove free liquid.

The excavation would extend at least 0.3 meters (1 foot) into the Lavery till. Additional soil would be excavated, as necessary, to remove essentially all the soil impacted by radioactivity. The extent of soil removed beyond the proposed limits would be determined by the use of DCGLs. Remedial action surveys would be performed during the course of the work to identify those areas that contain contaminated soil above the DCGLs and those that do not. Soil with radioactivity concentrations exceeding the DCGLs would be removed.

For estimating purposes, the following assumptions have been made:

- The excavation is assumed to extend 0.3 meters (1 foot) into the Lavery till or more in those cases where the underground structure extends into the Lavery till.
- All of the soil to be excavated would be radioactive and processed through a Soil Drying Facility (see Section C.4.3) and disposed of off site.
- Soil in the North Plateau Groundwater Plume source area and immediately downgradient would be disposed of as Class A low-level radioactive waste.
- The remainder of the soil would be disposed of as low-specific-activity waste and placed in containers for transportation to the disposal facility.

Removal of Underground Structures

The design and construction of the below-grade cells are similar to the tower cells (see Section C.3.1.1.2); they would also be freestanding structures if they were physically segregated from the remainder of the Main Plant Process Building. The walls, floors, and ceilings of these cells are composed of either high-density (2,400 kilograms per cubic meter [235 pounds per cubic foot]) or standard density (3,800 kilograms per cubic meter [150 pounds per cubic foot]) reinforced concrete that is up to 1 meter (3 feet) thick.

The demolition of below-grade cells and structures would be coordinated with the removal of the three underground tanks, the underground piping, and contaminated soil associated with the source area of the North Plateau Groundwater Plume. After soil is excavated to expose their structures, the below-grade cells would be demolished with conventional demolition equipment operating under a fog spray, as necessary, and with diamond-wire saws.

The ceilings and walls would be segmented and removed using diamond-wire saws and cranes. The cut segments would be sized to fit into appropriate containers. Once the walls have been removed, conventional demolition equipment would be used to remove the floor slabs and foundations.

All remaining concrete floor slabs and foundations in the area, including those outside of the excavation, would also be removed. The nearly 500 foundation pilings supporting the Main Plant Process Building would be cut just below the limit of excavation. Additional piling removal would be considered if contaminants are found to have migrated further down the pilings. Assumptions have been made regarding the pile removal that involve potentially numerous work crews working together in a small space (excavation and concrete demolition would be proceeding at the same time as the pile removal). This working arrangement might cause reductions in work productivity to occur, increasing cost and decreasing the level of safety against worker injury. The work involved in this effort is relatively common; however, coordination among the work crews would need close attention.

All demolition debris would be managed as low-specific-activity waste and disposed of off site at a low-level radioactive waste disposal facility.

Removal of Underground Tanks and Piping

The three underground tanks and underground piping within the excavated area would be removed and disposed of as radioactive waste, as appropriate. Planning for underground line removal would take into account two lines of particular interest: Waste Transfer Line 7P-120 and the off-gas line running between the Vitrification Facility and the 01-14 Building. Waste Transfer Line 7P-120, which is shown on Figure C-15, has been estimated to contain more than 90 percent of the radioactivity in the underground lines in the Main Plant Process Building area.

Waste Transfer Line 7P-120, as well as 7P-112 and 7P-113, would be isolated and completely filled with grout. These pipes would be removed from the point of origin within the Main Plant Process Building, to beyond the proposed downgradient barrier wall (see Section C.3.1.1.7), and into WMA 3. Pipes left in the ground would be properly plugged and sealed.

The off-gas line, which runs in the Off-Gas Trench just below-grade with other lines, is also expected to contain high levels of residual radioactivity. The Off-Gas Trench would be removed along with the pipelines it contains. Rubble from the Trench is expected to be disposed of off site as construction and demolition debris. Soil beneath the underground structures would be excavated 0.3 meters (1 foot) into the Lavery till.

The wastewater piping under the Main Plant Process Building would be removed and disposed of as Class A low-level radioactive waste and the surrounding soils as low-specific-activity waste. All contaminated piping running into other WMAs would be removed. This process would apply to radioactive lines only. Nonradioactive sanitary lines and utility lines would remain in place in cases where this is practicable because removal would involve extensive excavation and these lines would not need to be maintained. Parking lots and roadways would be removed because they would otherwise need to be maintained.

C.3.1.1.9 Site Restoration

Once the below-grade structures of the Main Plant Process Building and Vitrification Facility, the three wastewater tanks, the underground piping, the remaining concrete floor slabs and foundations, and the underlying contaminated soils associated with the source area of the North Plateau Groundwater Plume have been removed, a final status survey would be performed in the excavation to verify that residual radioactivity levels do not exceed DCGLs. Arrangements would also be made for an independent verification survey. Confirmatory sampling for RCRA constituents of concern would be performed, and remedial actions would be based on the results.

After the verification survey is completed, the area would be filled with appropriate clean backfill material and then graded, as necessary, to restore it to a near natural appearance. It is assumed in the estimates that the backfill would be composed entirely of clean earth brought in for this purpose.

C.3.1.1.10 Disposition of Support Facility Materials

The sheet pilings installed on the upgradient sides of the excavation would be removed as the excavation is backfilled and disposed of as low-specific-activity waste, as would the groundwater extraction wells. It is assumed that the components of the groundwater treatment system would be disposed of as low-specific-activity waste, with the ion-exchange media disposed of as Class A low-level radioactive waste. It is assumed that the ventilation exhaust equipment associated with the confinement structure would be disposed of as low-specific-activity waste, with the confinement structure itself being disposed of as uncontaminated construction and demolition debris.

C.3.1.1.11 Estimated Waste to be Generated

The estimated waste volumes expected to be generated under the Sitewide Removal Alternative in WMA 1 are presented in **Table C-15**. The estimate includes the modification of the Load-In/Load-Out Facility and the operation and demolition of the Interim Storage Facility (Dry Cask Storage Area) associated with the high-level waste canister removal.

Table C-15 Estimated Waste to be Generated: Waste Management Area 1

<i>Waste Type</i>	<i>Waste Volume (cubic feet)</i>
Construction and Demolition Debris	440,000
Hazardous Waste	83
Low-level Radioactive Waste	
Low Specific Activity	3,500,000
Class A	280,000
Class B	3,100
Class C	9,000
Greater-Than-Class C Waste	0
Mixed Low-level Radioactive Waste	1,400
Transuranic Waste	24,000

Notes: The estimated waste volumes are based on commercial disposal and are presented with two significant figures. To convert cubic feet to cubic meters, multiply by 0.028317.

Source: WSMS 2009a.

C.3.1.2 Waste Management Area 2: Low-Level Waste Treatment Facility Area

The Sitewide Removal Alternative approach to closing WMA 2 is removal of all remaining surface structures and concrete floor slabs, removal of all below-grade piping, removal of the contaminated waste and sediment contained in Lagoon 1, excavation of all contaminated sediment from Lagoons 2 and 3, removal of liners from Lagoons 4 and 5 and excavation of any underlying contaminated soil, and restoration of the surface to a natural contour.

C.3.1.2.1 Removal of Structures/Facilities

Low-Level Waste Treatment Facility

The contents of skid-mounted wastewater processing modules, ion-exchange media, and activated carbon would be flushed to the waste packaging area, where they would be packaged for transport off site and disposal as low-specific-activity waste. The wastewater processing equipment and piping from the building would be removed and reduced in size, as appropriate; packaged; placed into containers; and transported off site for disposal as low-specific-activity waste.

The waste packaging area would be demolished using appropriate controls such as fog spray, with the debris, including the sump liner, being placed into containers for disposal off site as low-specific-activity waste. The remainder of the Low-Level Waste Treatment Facility and its floor slab would then be demolished by conventional methods without confinement and the surrounding soils excavated, as needed, to satisfy the DCGLs. The debris and excavated soil would be handled as low-specific-activity waste, placed into containers, and transported off site for disposal.

A final radiological status survey would be performed in the area and arrangements made for an independent verification survey. After the surveys have been completed and any necessary confirmatory sampling of RCRA constituents of concern has been performed, the excavation would be filled with appropriate clean backfill material and contoured to grade.

Neutralization Pit

The liner, concrete walls, and floor of the Neutralization Pit and the underground lines in the immediate area would be demolished and removed with the debris being disposed of as low-specific-activity waste.

After completion of this work, a larger excavation would be performed as part of the WMA 2 remediation. Following that, a final status survey would be performed to include the Neutralization Pit excavated area and arrangements made for an independent verification survey. After the surveys have been completed and any necessary confirmatory sampling of RCRA constituents of concern has been performed, the excavation would be filled with appropriate clean backfill material and contoured to grade.

Old Interceptor

The Old Interceptor would be demolished using a process similar to that used for the Neutralization Pit, with appropriate radiological controls. The concrete rubble would be managed as low-specific-activity waste and placed in lift liners for offsite disposal. The valve pit and underground lines in the immediate area would be removed and disposed of as low-specific-activity waste.

After completion of this work, a larger excavation would be performed as part of the WMA 2 remediation. Following that, a final status survey would be performed to include the Old Interceptor excavated area and arrangements made for an independent verification survey. After the surveys have been completed and any

necessary confirmatory sampling of RCRA constituents of concern has been performed, the excavation would be filled with appropriate clean backfill material and contoured to grade.

New Interceptors

The New Interceptors and the valve pit would be demolished using a process similar to that used for the Neutralization Pit, with the rubble being disposed of as low-specific-activity waste. Underground lines in the immediate area would also be removed and disposed of as low-specific-activity waste.

After completion of this work, a larger excavation would be performed as part of the WMA 2 remediation. Following that, a final status survey would be performed to include the New Interceptors' excavated area and arrangements made for an independent verification survey. After the surveys have been completed and any necessary confirmatory sampling of RCRA constituents of concern has been performed, the excavation would be filled with appropriate clean backfill material and contoured to grade.

Fire Brigade Training Area

Surface and subsurface soils that have been impacted by past operations at the Fire Brigade Training Area would be excavated and disposed of off site. The excavated material would be packaged and characterized for disposal; it is assumed to be classified as low-specific-activity waste.

Sometime after completion of the excavation of impacted soils, a larger excavation would be performed as part of the WMA 2 remediation. Following that, a final status survey would be performed to include the Fire Brigade excavated area, and arrangements would be made for an independent verification survey. A RCRA confirmatory status survey would also be performed. After the surveys have been performed and any necessary sampling and analysis for constituents of concern have been completed, the excavation would be filled with appropriate clean backfill material and contoured to grade.

C.3.1.2.2 Concrete Floor Slabs and Foundations

The concrete floor slabs of the 02 Building, Test and Storage Building, Vitrification Test Facility, Maintenance Shop, Maintenance Storage Area, Vehicle Maintenance Shop, and Industrial Waste Storage Area would be demolished by conventional means and the surrounding soils excavated, as needed, to satisfy the DCGLs. The demolition debris is assumed to be disposed of as uncontaminated construction and demolition debris.

A final status survey would be performed in the excavated areas and arrangements made for an independent verification survey. After the surveys have been completed and any necessary confirmatory sampling of RCRA constituents of concern has been performed, the excavations would be filled with appropriate clean backfill material and contoured to grade.

C.3.1.2.3 Decommissioning of the Lagoons

Lagoon 1

Preparation for decommissioning of Lagoon 1 would include fabrication of a confinement structure. Section C.4.6.6 describes the conceptual design of this structure, which would consist of a single-span metal building large enough to cover the lagoon area excavation and accommodate heavy equipment.

The confinement structure would be erected over the Lagoon 1 area to prevent any airborne releases during excavation. The topsoil and clay cap, hardstand waste, and contaminated sand and gravel underlying Lagoon 1 would be excavated and evaluated for waste characterization.

The excavation is expected to encompass a 30.4- by 30.4-meter (100- by 100-foot) area and extend approximately 0.6 meters (2 feet) into the Lavery till, with a total depth of approximately 4.3 meters (14 feet). Sheet piling would be installed around the excavation to limit groundwater intrusion. As with removal of the North Plateau Groundwater Plume source area in WMA 1, DCGLs would be used to determine the extent of contaminated sediment and soil removal.

The excavated hardstand waste is assumed to be disposed of as Class A low-level radioactive waste. It is assumed that the underlying sand and gravel would be disposed of as Class C low-level radioactive waste.

Following removal of Lagoon 1 within the confinement structure, additional surrounding soils would also be removed. This area extends from about the interceptors to Lagoon 2 and is approximately 5,800 square meters (64,000 square feet) in size. Soils would be excavated down to about 4.3 meters (14 feet) and disposed of off site as low-specific-activity waste. By removing the larger area around Lagoon 1 all the way from Lagoon 2 to the interceptors, any potential areas of secondary contamination would be effectively remediated.

After completion of this work, a final status survey would be performed in the excavated area and arrangements made for an independent verification survey. After the surveys have been completed and any necessary confirmatory sampling of RCRA constituents of concern has been performed, the excavation would be filled with appropriate clean backfill material.

It is assumed that the ventilation exhaust equipment associated with the confinement structure would be disposed of as low-specific-activity waste, with much of the confinement structure itself being disposed of as uncontaminated construction and demolition debris.

Lagoon 2

Lagoon 2 was excavated through the sand and gravel unit into the underlying Lavery till. There is little to no groundwater flow from the sand and gravel unit into the lagoon. Groundwater flow in the Lavery till is vertically downward toward the underlying Kent Recessional Unit. Before excavation activities associated with decommissioning would begin, aqueous waste remaining in Lagoon 2 would be pumped to the Low-Level Waste Treatment Facility for treatment.

As part of the decommissioning process, equipment and piping would be removed from the pump shed, the shed would be demolished, and buried piping and conduit would be removed using appropriate radiological controls. The resulting equipment and building debris would be disposed of as low-specific-activity waste. The buried piping would be managed as Class A low-level radioactive waste. The stairways would be removed, cut into manageable sizes, and disposed of as low-specific-activity waste.

Using appropriate radiological controls and conventional excavation methods, contaminated lagoon sediment and a limited thickness of the underlying Lavery till would be removed. As with Lagoon 1, DCGLs would be used to determine the extent of contaminated sediment and soil removal. It is expected that a total of 1 meter (4 feet) of soil/sediment would be removed, including the upper 0.3 meters (1 foot) of the underlying Lavery till. It is assumed that the removed sediment and soil would be disposed of as Class A low-level radioactive waste.

After completion of this work, a final status survey would be performed in the excavated area and arrangements made for an independent verification survey. After the surveys and any necessary confirmatory sampling of RCRA constituents of concern have been completed, the excavation would be filled with appropriate clean backfill material.

Lagoon 3

Similar to Lagoon 2, Lagoon 3 was excavated through the sand and gravel unit into the underlying Lavery till. There is little to no groundwater flow from the sand and gravel unit into the lagoon. Groundwater flow in the Lavery till is vertically downward toward the underlying Kent Recessional Unit. Before excavation activities associated with decommissioning would begin, aqueous waste remaining in Lagoon 3 would be discharged to Erdman Brook through the SPDES-permitted discharge.

The Lagoon 3 decommissioning process would be similar to the Lagoon 2 process. The stainless steel liner would be removed from the discharge weir and would be disposed of as low-level radioactive waste. Using appropriate radiological controls and conventional excavation methods, contaminated lagoon sediment and a limited thickness of the underlying Lavery till would be removed. DCGLs would be used to determine the extent of contaminated sediment and soil removal. It is expected that a total of 0.6 meters (2 feet) of soil/sediment would be removed, including a thin layer of the underlying Lavery till. It is assumed that the removed sediment and soil would be disposed of as Class A low-level radioactive waste.

After completion of this work, a final status survey would be performed in the excavated area and arrangements made for an independent verification survey. After the surveys and any necessary confirmatory sampling of RCRA constituents of concern have been completed, the excavation would be filled with compacted clay.

Lagoons 4 and 5

Lagoons 4 and 5 were excavated into the vadose zone of the sand and gravel unit, and an impermeable liner was installed after their construction to limit releases to the sand and gravel unit.

During decommissioning, the liners in Lagoons 4 and 5 would be removed. Radioactively contaminated soil beneath the liners would be removed to meet DCGLs. For estimating purposes, it is assumed that approximately 0.3 meters (1 foot) of underlying soil is contaminated above the DCGLs and that the removed sediment, soil, and liners would be disposed of as Class A low-level radioactive waste. Because Lagoons 4 and 5 and their liners are in the vadose zone of the sand and gravel unit, interaction with the groundwater would be successfully managed.

After completion of this work, a final status survey would be performed in the area and arrangements made for an independent verification survey. After the surveys and any necessary confirmatory sampling of RCRA constituents of concern have been completed, the excavation would be filled with compacted clay.

C.3.1.2.4 Solvent Dike

The Solvent Dike would be excavated. The excavated material is assumed to be disposed of off site as low-specific-activity waste.

After completion of this work, a larger excavation would be performed as part of the WMA 2 remediation. Following that, a final status survey would be performed in the excavated area and arrangements made for an independent verification survey. After the surveys and any necessary confirmatory sampling of RCRA constituents of concern have been completed, the excavation would be filled with appropriate clean backfill material and contoured to grade.

C.3.1.2.5 Maintenance Shop Leach Field

The leach field components would be removed by conventional means without confinement. This material would be disposed of as low-level radioactive waste because it is assumed that this area has been impacted by the North Plateau Groundwater Plume, although it is unclear whether the depth to be excavated would encounter the saturated zone. This work would likely be performed concurrently with the North Plateau Groundwater Plume excavation.

After completion of this work, a final status survey would be performed in the excavated area and arrangements made for an independent verification survey. After the surveys and any confirmatory sampling of RCRA constituents of concern have been completed, the excavation would be filled with appropriate clean backfill material and contoured to grade.

C.3.1.2.6 Remaining Underground Piping

All underground wastewater lines within WMA 2 that remain after facility removal and lagoon excavations would be removed and disposed of as Class A low-level radioactive waste. A final status survey would be performed in each excavated area and arrangements made for an independent verification survey. After the surveys have been completed and any necessary confirmatory sampling of RCRA constituents of concern has been performed, the excavated areas would be filled with appropriate clean backfill material and contoured to grade.

C.3.1.2.7 Estimated Waste to be Generated

The estimated waste volumes expected to be generated under the Sitewide Removal Alternative in WMA 2 are presented in **Table C-16**.

Table C-16 Estimated Waste to be Generated: Waste Management Area 2

<i>Waste Type</i>	<i>Waste Volume (cubic feet)</i>
Construction and Demolition Debris	50,000
Hazardous Waste	0
Low-level Radioactive Waste	
Low Specific Activity	1,400,000
Class A	340,000
Class B	0
Class C	33,000
Greater-Than-Class C Waste	0
Mixed Low-level Radioactive Waste	0
Transuranic Waste	0

Note: The estimated waste volumes are based on commercial disposal and are presented with two significant figures. To convert cubic feet to cubic meters, multiply by 0.028317.

Source: WSMS 2009a.

C.3.1.3 Waste Management Area 3: Waste Tank Farm Area

The Sitewide Removal Alternative closure approach for WMA 3 includes the removal of all facilities, including Tanks 8D-1, 8D-2, 8D-3, and 8D-4 and their associated vaults; the high-level radioactive waste mobilization and transfer pumps; the High-Level Waste Transfer Trench; the Permanent Ventilation System Building; the STS and STS Support Building; the Equipment Shelter and Condensers; the Con-Ed Building; the underground process and STS wastewater and utility lines; and all remaining concrete slabs and

foundations. All contaminated soil and groundwater would be remediated to levels supporting unrestricted release.

C.3.1.3.1 Demolition of the Supernatant Treatment System Support Building and Tanks 8D-1, 8D-2, 8D-3, and 8D-4 and Associated Vaults

The closure of the Waste Tank Farm Area in WMA 3 would be performed within the confines of the Waste Tank Farm Waste Processing Facility, which is described in Section C.4.2. Closure activities would include a number of separate tasks including, but not limited to, removal and processing of any mobile radionuclide inventory from the tanks, demolition of the tanks and associated vaults and the processing and packaging of this waste, decontamination and characterization of waste packages, and loading and offsite shipment of packaged waste.

Supernatant Treatment System Support Building

The STS Support Building would be demolished under the Waste Tank Farm Waste Processing Facility enclosure. Most of the second floor of the STS Support Building is uncontaminated and would be demolished in a hands-on manner. The equipment and structural components of the second floor of the STS Support Building would be surveyed and a spray fixative applied, if necessary. The equipment would be removed, characterized, packaged, and disposed of at appropriate offsite disposal facilities. After the equipment has been removed, the second floor of the structure would be demolished using a demolition machine equipped with a demolition hammer and shear. The sheet metal and structural steel would be removed, reduced in size, packaged, and disposed of at appropriate offsite disposal facilities.

The first floor of the STS Support Building includes the STS Valve Aisle, which was contaminated during STS operations. The uncontaminated portions of the first floor outside of the STS Valve Aisle would be demolished using manned demolition machines. The STS Valve Aisle would be demolished remotely. All equipment located outside of the STS Valve Aisle would be removed, packaged, and disposed of as low-specific-activity waste at an offsite disposal facility.

A spray fixative would be applied to the interior of the STS Valve Aisle. The steel shield walls and roof of the STS Valve Aisle would be removed remotely using a telescoping mast equipped with cutting, grappling, and lifting tools. The telescoping mast works mainly in the vertical direction; it employs a series of tubes that fit inside each other, and, when extended, form a mast longer than any of the individual tubes. The mast is operated hydraulically (remotely if necessary) and would be able to operate the various end attachments discussed previously. The steel shielding would be transferred to the Remote-Handled Work Cell of the Waste Tank Farm Waste Processing Facility for size reduction and packaging before being disposed of at an offsite low-level radioactive waste disposal facility. The concrete floor of the STS Valve Aisle would be demolished using the remotely operated demolition hammer attached to a telescoping mast. All demolition debris would be packaged in containers and disposed of as low-specific-activity waste at an offsite disposal facility.

Removal of Supernatant Treatment System Equipment in Tank 8D-1

An estimated 2.5 meters (8 feet) of soil overlies the vaults of Tanks 8D-1 and 8D-2, which would be removed using both manned and remotely operated excavation equipment. The soil would be packaged and disposed of as low-specific-activity waste at an offsite disposal facility. Once the soil has been removed from above the Tank 8D-1 vault, the STS equipment in Tank 8D-1 would be removed, processed, and packaged for disposal.

The four ion-exchange columns contain radioactively contaminated zeolite. The zeolite in the ion-exchange columns would be backflushed through the column J nozzles to the Liquid Waste Process Cell of the Waste Tank Farm Waste Processing Facility for processing and stabilization with grout. The zeolite/grout mixture

would be placed into 208-liter (55-gallon) drums for curing. Once the mixture has cured, the drums would be transferred to the decontamination station in the Remote-Handled Work Cell. It is assumed that the stabilized zeolite will be disposed of as transuranic waste.

The STS equipment in Tank 8D-1 would be removed using a telescoping mast system. A 27-metric ton (30-ton) hoist and trolley would transport the equipment to the Remote-Handled Work Cell, where the telescoping work arm platforms equipped with cutting torches would reduce the size of the equipment for waste packaging. The packaged waste would be decontaminated in the Waste Package Decontamination Area, after which it would be transferred to the Nondestructive Assay Cell for waste characterization, as required by the waste acceptance criteria of the disposal facility. After the packages have been characterized, they would be transferred from the Nondestructive Assay Cell to the Remote-Handled Cask Loading Cell and packaged into appropriate transportation casks as required. The loaded casks would be transferred to the Transport Loading Area, where they would be loaded onto an appropriate transport trailer for shipping to a waste disposal facility.

It is assumed that the processed STS equipment would be disposed of as Class C low-level radioactive waste. Residual ion-exchange and filter media in the equipment would be transferred into waste containers for disposal.

Removal of Residual Waste from Tank 8D-1

The vault roofs and tops of Tanks 8D-1 and 8D-2 would be removed remotely before the residual inventory is removed from these tanks. The tanks would be accessed by remotely demolishing the vault roofs with the telescoping mast equipped with a demolition hammer. Grapples would be used to remove the vault debris, after which it would be packaged for offsite disposal as low-specific-activity waste. The risers would be segmented, packaged, and characterized for offsite disposal. The waste class of the riser segments is expected to range from Class A low-level radioactive to transuranic waste, depending on its location.

The carbon steel tank tops would be cut away by rigging sections of the tank tops to the Z-mast crane and cutting the sections using a torch to free the rigged section. The cut section would be transferred to the Remote-Handled Work Cell for additional size reduction and packaging using the two telescoping work arm platforms equipped with grappling equipment, torch, and saw attachments.

Any residual mobile radionuclide inventory in Tanks 8D-1 and 8D-2 would be removed using a Waste Dislodging and Conveyance System. The zeolite and solids in the bottom of Tank 8D-1 would be transferred to the liquid waste storage tanks in the Liquid Waste Process Cell using the transfer pumps and associated piping. This waste would be pumped from the storage tanks to the centrifugal dewatering system, where the solids would be separated. The solids would be transferred to the Container Fill Area of the Liquid Waste Process Cell, where they would be mixed with grout produced in the Grout Batch Plant. The solids/grout mixture would be placed into 208-liter (55-gallon) drums for curing. Once the mixture has cured, the drums would be transferred to the decontamination station in the Remote-Handled Work Cell. It is assumed that the stabilized solids would be disposed of as transuranic waste.

Tanks 8D-1 and 8D-2

Once the STS equipment and mobile waste have been removed from Tanks 8D-1 and 8D-2, the tanks would be segmented using a telescoping mast system and dual-arm work platform equipped with torch-cutting attachments. The residual radionuclide inventory associated with the tank shells of Tanks 8D-1, 8D-2, and 8D-4 would require this waste to be packaged in 208-liter (55-gallon) drums. This would require initial segmentation within the tanks, followed by additional size reduction to allow placement within the

208-liter (55-gallon) drums. After initial cutting, the tank segments would be transferred to the Remote-Handled Work Cell using the hoist and trolley system.

The tank walls, supporting columns, horizontal gridwork, and floor would be segmented and processed in a similar manner to the tops of the tanks, as described previously. The tank segments would be transferred to the Remote-Handled Work Cell for size reduction and packaging using the two telescoping work arm platforms equipped with grappling equipment, torch, and saw attachments to segment and package the waste. The waste packages would be decontaminated in the Waste Package Decontamination Area and then characterized for waste disposal in the Nondestructive Assay Cell. The waste class of the tank segments would range from Class C low-level radioactive waste (Tank 8D-1) to transuranic waste (Tank 8D-2). The waste packages would be transferred to the Remote-Handled Cask Loading Cell for loading into shipping casks followed by transfer to the Transport Loading Area, where the casks would be loaded onto trailers for shipment.

Tanks 8D-3 and 8D-4

The soil overlying the vault would be removed using the Waste Tank Farm Waste Processing Facility telescoping mast system with appropriate tools. The soil would be packaged and disposed of as low-specific-activity waste. The Waste Tank Farm Waste Processing Facility telescoping mast system would then be used to demolish the valve pit, the pump pit, and the 0.6-meter-thick (2-foot-thick) vault roof using demolition hammers or similar types of equipment. The debris would be packaged and disposed of as low-specific-activity waste. The top of Tanks 8D-3 and 8D-4 would be removed using the Waste Tank Farm Waste Processing Facility telescoping mast system with a work arm equipped with a torch. The tank tops would be transferred into the Remote-Handled Work Cell for additional segmentation, as necessary, for packaging.

The telescoping vertical mast would be used to deploy the Waste Dislodging and Conveyance System inside Tanks 8D-3 and 8D-4 to remove the mobile waste in the tanks and transfer it to the Liquid Waste Process Cell for processing and stabilization with grout. The cooling coils contained in Tanks 8D-3 and 8D-4 would then be removed using grapples and/or mechanical shear tools as required. The tank shells would be segmented with the telescoping vertical mast and dual-arm work platform equipped with torch- and shear-cutting tools. The tank segments would be transferred into the Remote-Handled Work Cell for additional size reduction and packaging. Tank 8D-3 is assumed to be Class B low-level radioactive waste based on its current estimated radionuclide inventory. Tank 8D-4 is assumed to be transuranic waste based on its current estimated radionuclide inventory.

Vaults of Tanks 8D-1, 8D-2, 8D-3, and 8D-4

After Tanks 8D-1, 8D-2, 8D-3, and 8D-4 have been removed, radiological surveys would be conducted to evaluate dose rates and levels of contamination remaining in the vaults. Depending upon the results, it may be possible to demolish the vaults using manned demolition equipment.

The perlite blocks and gravel underlying Tanks 8D-1 and 8D-2 are assumed to be removed with manned equipment such as long reach hydraulic excavators, packaged, and disposed of as low-specific-activity waste at an offsite disposal facility. The telescoping arm and dual-arm work platform equipped with a torch would be used to segment the pans in the vaults in Tanks 8D-1 and 8D-2. The pan segments would be transferred to the Remote-Handled Work Cell for additional size reduction and packaging. The tank pans are expected to be disposed of as Class A low-level radioactive waste.

Sheet piling would be driven around the tank vaults to stabilize the surrounding soil before the tank vaults are removed. The tank vaults would be demolished using either manned hydraulic excavators or a remotely telescoping arm and dual-arm work platform equipped with a demolition hammer. The vault debris would be packaged and disposed of as low-specific-activity waste at an offsite disposal facility. The soil beneath the

vaults would be surveyed, and any contaminated soil with radioactivity concentrations exceeding the established DCGLs or other applicable criteria would be removed.

C.3.1.3.2 Removal of Waste Tank Pumps and Pump Support Structures

Tank 8D-1 contains five high-level radioactive waste mobilization pumps, and Tank 8D-2 contains four of these centrifugal pumps. Each pump is approximately 2.4 meters (8 feet) long and is supported by a 25.4-centimeter (10-inch) stainless steel pipe column that is 15.2 meters (50 feet) long.

Tanks 8D-1, 8D-2, and 8D-4 each contain a high-level radioactive waste transfer pump. These centrifugal multistage turbine type pumps are each supported by a 35.6-centimeter (14-inch) pipe column, with an overall length of more than 15.2 meters (50 feet) for tanks 8D-1 and 8D-2 and approximately 6 to 8 meters (20 to 25 feet) in length for Tanks 8D-3 and 8D-4. Like the mobilization pumps, the transfer pumps were driven by 150-horsepower electric motors. Tanks 8D-1 and 8D-2 also contain an STS suction pump, which is assumed to be the same size as the transfer pumps.

The mobilization, transfer, and STS suction pumps are radiologically contaminated. The transfer and suction pumps will likely have more contamination than the mobilization pumps because high-level radioactive waste passed through the entire length of these pumps, rather than impacting only the lower portions of the latter.

Each one of the pumps would be removed using appropriate radiological controls. The pumps would be cut into sections during removal and packaged for disposal in the field. It is assumed that some portions of the pumps would be classified as low-level radioactive waste and others as transuranic waste.

The methods and controls needed for safe removal of the pumps have been demonstrated with the previous pump removals; however, the segmenting methods and controls have not been demonstrated. The pumps would have to be segmented to fit inside of waste containers for eventual offsite disposal.

The pump support structures would be removed in connection with removal of the pumps and the material disposed of off site as construction and demolition debris.

C.3.1.3.3 Removal of High-Level Waste Transfer Trench Piping

The High-Level Waste Transfer Trench itself is not expected to be radiologically contaminated because the piping did not leak and contamination has not been detected in water collected in the trench.

Using appropriate radiological controls, the piping would be cut into sections, packaged, and transported to an offsite low-level radioactive waste disposal facility for disposal as Class A low-level radioactive waste. The piping and other equipment in the pits would also be cut into sections and disposed of in this manner, coordinated with removal of the waste tank pumps.

After the piping has been removed, radiological surveys would be performed in the empty transfer trench and it would be demolished and disposed of off site as uncontaminated construction and demolition debris.

C.3.1.3.4 Demolition of the Permanent Ventilation System Building

The equipment inside the Permanent Ventilation System Building would be removed, packaged, and disposed of, and the building would be demolished through the use of a front-end loader and other concrete demolition equipment. Demolition would include both the superstructure and all concrete slabs and foundations associated with it. All demolished equipment would be disposed of as low-specific-activity waste, with the

exception of the ventilation system media, which would be packaged and disposed of as Class A low-level radioactive waste.

Upon completion of the foundation demolition and removal of any remaining waste materials, a final status survey would be performed over the footprint of the building, and arrangements would be made for any necessary independent verification surveys. After the surveys have been performed and any necessary sampling and analysis of constituents of concern have been completed, the disturbed area would be graded and filled with appropriate clean backfill material, as needed.

C.3.1.3.5 Demolition of the Equipment Shelter and Condensers

Any remaining liquid would be drained from the system. The equipment would be removed, packaged, and disposed of off site as Class A low-level radioactive waste. The structure would be demolished without containment using conventional methods, with the floor slab and impacted soil removed, as needed. As with other remediation areas, DCGLs would be used to determine the extent of contaminated soil removal. The demolition debris would be disposed of off site as uncontaminated construction and demolition debris.

Arrangements would be made for any necessary independent verification surveys. After the surveys have been performed and any necessary sampling and analysis of constituents of concern have been completed, the excavation would be filled with appropriate clean backfill material and contoured to grade.

C.3.1.3.6 Demolition of the Con-Ed Building

The structure would be demolished without containment using conventional methods, with the floor slab and impacted soil removed, as needed. As with other surface remediation areas, DCGLs would be used to determine the extent of contaminated soil removal. The demolition debris would be disposed of off site as uncontaminated construction and demolition debris.

Arrangements would be made for any necessary independent verification surveys. After the surveys have been performed and any necessary sampling and analysis of constituents of concern have been completed, the excavation would be filled with appropriate clean backfill material and contoured to grade.

C.3.1.3.7 Decontamination and Demolition of the Waste Tank Farm Waste Processing Facility

Portions of the Waste Tank Farm Waste Processing Facility and its associated equipment would become contaminated while supporting the closure of the Waste Tank Farm Area. The interior of the Waste Tank Farm Waste Processing Facility would be surveyed to assess contamination levels associated with building surfaces and equipment. A spray fixative would be applied to the external surfaces of equipment and the internal surfaces of the walls and ceiling of the Waste Tank Farm Waste Processing Facility. Equipment and stainless steel liners would be dismantled, reduced in size, packaged, and disposed of at an offsite radioactive waste disposal facility.

The Waste Tank Farm Waste Processing Facility would be demolished after the post-excavation survey has been completed, with the resulting excavation filled with appropriate clean backfill material. The enclosure would be demolished using conventional demolition equipment, such as hydraulic excavators equipped with demolition hammers and shears. The demolition debris would be packaged as low-specific-activity waste and transported to an offsite radioactive waste disposal facility.

Once the facility has been removed, any contaminated soil generated during demolition would be removed and disposed of as low-specific-activity waste. A final status survey would be performed in the area impacted by demolition of the enclosure to establish that residual radioactivity levels do not exceed the established DCGLs.

After the survey is complete, additional appropriate clean backfill material would be placed and the area graded to a near natural appearance.

C.3.1.3.8 Site Restoration

Removal of Tanks 8D-1, 8D-2, 8D-3, and 8D-4 and their associated vaults would result in a large excavation under the Waste Tank Farm Waste Processing Facility. Post-excavation surveys would be performed before the Waste Tank Farm Waste Processing Facility is demolished to verify that residual radioactivity levels do not exceed the established DCGLs and that concentrations of RCRA hazardous constituents are below guidance limits. After the surveys are complete, the excavation would be filled with appropriate clean backfill material under the confinement provided by the Waste Tank Farm Waste Processing Facility.

C.3.1.3.9 Estimated Waste to be Generated

The estimated waste volumes expected to be generated under the Sitewide Removal Alternative in WMA 3 are presented in **Table C–17**. The estimate includes the Waste Tank Farm Waste Processing Facility construction, operation, and demolition.

Table C–17 Estimated Waste to be Generated: Waste Management Area 3 ^a

<i>Waste Type</i>	<i>Waste Volume (cubic feet)</i>
Construction and Demolition Debris	120,000
Hazardous Waste	0
Low-level Radioactive Waste	
Low Specific Activity	2,100,000
Class A	66,000
Class B	870
Class C	8,500
Greater-Than-Class C Waste	0
Mixed Low-level Radioactive Waste	0
Transuranic Waste	11,000

^a If the waste incidental to reprocessing process is not applied to the high-level radioactive waste storage tanks and waste residuals in the tanks, under the Sitewide Removal Alternative approximately 500 cubic meters (18,000 cubic feet) of waste would be added to the inventory of high-level radioactive waste already stored on site, and the amount of low-level radioactive waste and transuranic waste shown in this table would be reduced by about 210 cubic meters (7,500 cubic feet) and 280 cubic meters (10,000 cubic feet), respectively. For Phase 1 of the Phased Decisionmaking Alternative, approximately 51 cubic meters (1,800 cubic feet) of waste would be added to the inventory of high-level radioactive waste, and the amount of low-level radioactive waste and transuranic waste would be reduced by about 32 cubic meters (1,100 cubic feet) and 19 cubic meters (670 cubic feet), respectively.

Notes: The estimated waste volumes are based on commercial disposal and are presented with two significant figures. To convert cubic feet to cubic meters, multiply by 0.028317.

Source: WSMS 2009a.

C.3.1.4 Waste Management Area 4: Construction and Demolition Debris Landfill

The Sitewide Removal Alternative closure approach for WMA 4 is exhumation of the CDDL and restoration of the surface to a natural contour.

C.3.1.4.1 Exhumation of the Construction and Demolition Debris Landfill

The overburden of the CDDL would be excavated and the wastes exhumed with a hydraulic excavator. Soil would be transported to a new Soil Drying Facility, described in Section C.4.3, for processing before being

sampled for characterization, packaged into containers, and transported as low-specific-activity waste to an offsite disposal facility.

Buried wastes would be exhumed in a slow, deliberate manner, paying close attention to the characteristics of the wastes being unearthed. Wastes deemed to be free of hazardous constituents, such as construction debris, typically would be placed into appropriate containers, sampled, and transported as low-specific-activity waste for disposal. When oversized materials are encountered, a hydraulic excavator equipped with a shear would be used within the excavation to cut them into pieces, as necessary, to prepare them for packaging.

Wastes that could contain hazardous waste, such as paint cans and batteries, would be segregated from the other wastes, characterized, and packaged in 208-liter (55-gallon) drums for disposal. Some of this waste is assumed to be disposed of as mixed low-level radioactive waste.

Site restoration work would occur after the North Plateau Groundwater Plume has been excavated. After the waste and any contamination have been removed from WMA 4, a final status survey would be performed to verify that residual radioactivity levels do not exceed the established DCGLs. An independent verification survey may be required. After the verification survey is complete and any necessary confirmatory sampling of RCRA constituents of concern has been performed, the area would be filled with appropriate clean backfill material and then contoured to grade.

C.3.1.4.2 Estimated Waste to be Generated

The estimated waste volumes expected to be generated under the Sitewide Removal Alternative in WMA 4 are presented in **Table C-18**.

Table C-18 Estimated Waste to be Generated: Waste Management Area 4

<i>Waste Type</i>	<i>Waste Volume (cubic feet)</i>
Construction and Demolition Debris	0
Hazardous Waste	0
Low-level Radioactive Waste	
Low Specific Activity	800,000
Class A	2,900
Class B	0
Class C	0
Greater-Than-Class C Waste	0
Mixed Low-level Radioactive Waste	2,000
Transuranic Waste	0

Notes: The estimated waste volumes are based on commercial disposal and are presented with two significant figures. To convert cubic feet to cubic meters, multiply by 0.028317.

Source: WSMS 2009a.

C.3.1.5 Waste Management Area 5: Waste Storage Area

The Sitewide Removal Alternative approach to closing WMA 5 includes demolition of Lag Storage Area 4 and the associated Shipping Depot, the Remote-Handled Waste Facility, and the Construction and Demolition Area; removal of all remaining concrete floor slabs; and disposal of demolition debris, waste, and contaminated soils at appropriate offsite disposal facilities.

C.3.1.5.1 Demolition of Lag Storage Area 4

The structures would be demolished without confinement, and the floor slabs and foundations and impacted surrounding soil would be removed, as needed. As with other surface remediation areas, DCGLs would be used to determine the extent of contaminated soil removal. The demolition debris and soil would be disposed of off site as construction and demolition debris. After completion of this work, a final status survey would be performed in the excavated area. After completion of removal of any contaminated soil found and the associated surveys of the area are performed, arrangements would be made for an independent verification survey. After the surveys have been completed and any necessary confirmatory sampling of RCRA constituents of concern has been performed, the excavations would be filled with appropriate clean backfill material and then contoured to grade.

C.3.1.5.2 Demolition of the Remote-Handled Waste Facility

Closure of the facility under an NYSDEC-approved RCRA closure plan would be coordinated with other demolition requirements. The Remote-Handled Waste Facility would be demolished by conventional methods without confinement after it has completed processing all equipment and waste requiring remote handling and characterization. Demolition of the structure would include removal of the underground tank vault; the rest of the building would be taken down, including subgrade structures and foundations.

The majority of the Remote-Handled Waste Facility would be classified as low-specific-activity waste. The office structure would be characterized as construction and demolition debris. The underground Waste Transfer Lines to Tank 8D-3 in WMA 3 would be grouted, removed, and disposed of as Class A low-level radioactive waste.

As with other surface remediation areas, DCGLs would be used to determine the extent of contaminated soil removal. After completion of this work, a final status survey would be performed in the excavated area and arrangements made for any necessary independent verification surveys. RCRA confirmatory sampling would also be performed. After completion of the surveys and sampling, the excavated area would be filled with appropriate clean backfill material and contoured to grade.

Removal of the Construction and Demolition Area

Surface soils, as well as any remaining concrete debris, would be excavated and removed from the construction and demolition area and disposed of off site. The excavated material would be packaged and characterized for disposal. It is assumed to be classified as construction and demolition debris and would be disposed of at a local sanitary landfill or construction and demolition debris landfill.

Upon completion of the excavation, a final status survey would be performed in the excavated area, and arrangements would be made for any necessary independent verification surveys. After the surveys have been performed and any necessary sampling and analysis of RCRA constituents of concern have been completed, the excavation would be filled with appropriate clean backfill material and contoured to grade.

C.3.1.5.3 Removal of Remaining Floor Slabs, Foundations, and Gravel Pads

All remaining concrete floor slabs and foundations would be removed, including those associated with the Lag Storage Building, Lag Storage Area 1, and Lag Storage Area 3. The Lag Storage Area 2 Hardstand would also be removed, along with the gravel pads associated with the Chemical Process Cell Waste Storage Area, hazardous waste storage lockers, the Cold Hardstand Area, Vitrification Vault and Empty Container Hardstand, Old/New Hardstand Area, and Lag Hardstand.

The floor slabs, foundations, hardstands, and gravel pads would be demolished by conventional means. As with other surface remediation areas, DCGLs would be used to determine the extent of contaminated soil removal. The demolition debris would be disposed of as uncontaminated construction and demolition debris.

A final status survey would be performed in the excavated areas. Soil with radioactivity concentrations exceeding the DCGLs would be removed and disposed of as low-specific-activity waste and the areas resurveyed. Arrangements would be made for independent verification surveys. After all of the surveys have been completed and any necessary confirmatory sampling of RCRA constituents of concern has been performed, the excavations would be filled with appropriate clean backfill material and contoured to grade.

C.3.1.5.4 Estimated Waste to be Generated

The estimated waste volumes expected to be generated under the Sitewide Removal Alternative in WMA 5 are presented in **Table C-19**.

Table C-19 Estimated Waste to be Generated: Waste Management Area 5

<i>Waste Type</i>	<i>Waste Volume (cubic feet)</i>
Construction and Demolition Debris	190,000
Hazardous Waste	0
Low-level Radioactive Waste	
Low Specific Activity	100,000
Class A	32,000
Class B	0
Class C	0
Greater-Than-Class C Waste	0
Mixed Low-level Radioactive Waste	0
Transuranic Waste	0

Notes: The estimated waste volumes are based on commercial disposal and are presented with two significant figures. To convert cubic feet to cubic meters, multiply by 0.028317.
Source: WSMS 2009a.

C.3.1.6 Waste Management Area 6: Central Project Premises

Under the Sitewide Removal Alternative, the Rail Spur, Demineralizer Sludge Ponds, Equalization Basin, Equalization Tank, Low-Level Waste Rail Packaging and Staging Area, Sewage Treatment Plant, and South Waste Tank Farm Area Test Tower would be removed, along with the remaining concrete floor slabs and foundations, asphalt pads, and gravel pads. Any contaminated soil, sediment, and groundwater in the area would be remediated to levels supporting unrestricted release.

C.3.1.6.1 Removal of Structures/Facilities

Rail Spur

The Rail Spur rail and ties would be removed and disposed of as construction and demolition debris. A small portion, about 700 square meters (7,500 square feet), of the Rail Spur ballast would be disposed of as low-specific-activity waste. The remaining uncontaminated ballast (approximately 92 cubic meters [3,290 cubic feet]) would be disposed of as construction and demolition debris.

Demineralizer Sludge Ponds

The ponds would be excavated to a total depth of approximately 1.6 meters (5 feet), with the material removed being disposed of off site as low-specific-activity waste. After completion of this work, a final status survey would be performed in the excavated areas. Soil with radioactivity concentrations exceeding DCGLs would be removed and the areas resurveyed. Arrangements would be made for any necessary independent verification surveys. RCRA confirmatory sampling would also be performed. After completion of the surveys and sampling, the excavated areas would be filled with appropriate clean backfill material and contoured to grade.

Equalization Basin

The Equalization Basin liner, as well as any impacted subgrade soil, would be removed and disposed of off site. As with other surface remediation areas, DCGLs would be used to determine the extent of contaminated soil removal. After completion of this work, a final status survey would be performed in the area and arrangements made for any necessary independent verification surveys. RCRA confirmatory sampling would also be performed. After completion of the surveys and sampling, the area would be filled with appropriate clean backfill material and contoured to grade.

Equalization Tank

The Equalization Tank would be demolished using conventional methods, and the resulting material would be disposed of off site as construction and demolition debris. As with other surface remediation areas, DCGLs would be used to determine the extent of contaminated soil removal. After completion of this work, a final status survey would be performed in the area and arrangements would be made for an independent verification survey. RCRA confirmatory sampling would also be performed. After completion of the surveys and sampling, the excavated area would be filled with appropriate clean backfill material and contoured to grade.

Low-Level Waste Rail Packaging and Staging Area

The Low-Level Waste Rail Packaging and Staging Area would be removed, and the demolition debris would be disposed of off site or staged on site for beneficial use. The concrete pads of the loading dock and preparation area would be demolished, and the demolition debris would be directly packaged for offsite transport and disposal. Although radioactive materials were managed in these areas, the concrete debris is not expected to be radiologically contaminated. It is assumed that the debris would be classified as construction and demolition debris and would be disposed of at a construction and demolition debris landfill or sanitary landfill.

The stone base below the concrete is also not expected to be contaminated and would be staged on site to be used for beneficial purposes (e.g., temporary haul road construction) or used as backfill for nearby excavation areas.

Upon completion of the pad demolition and excavation and removal of the stone base, a final status survey would be performed in the excavated area, and arrangements would be made for any necessary independent verification surveys. After the surveys have been performed and any necessary sampling of RCRA constituents of concern have been completed, the disturbed area would be filled with appropriate clean backfill material and contoured to grade, as needed.

Sewage Treatment Plant

This facility and the underground concrete tanks would be completely removed using conventional demolition methods. The concrete foundation would be removed, as well as impacted subgrade soils. As with other

surface remediation areas, DCGLs would be used to determine the extent of contaminated soil removal. It is assumed that the demolition debris would be disposed of off site as construction and demolition debris. Any removed soil with radioactivity concentrations that exceed the DCGLs would be disposed of as low-specific-activity waste.

After completion of this work, a final status survey would be performed in the excavated area and arrangements made for any necessary independent verification surveys. After completion of the surveys and any necessary confirmatory sampling of RCRA constituents of concern, the excavated area would be filled with appropriate clean backfill material and contoured to grade.

South Waste Tank Farm Test Tower

This test tower would be removed using conventional demolition methods, and the debris would be disposed of off site as construction and demolition debris. After completion of this work, a final status survey would be performed in the excavated area and arrangements made for any necessary independent verification surveys. RCRA confirmatory sampling would also be performed. After completion of the surveys and sampling, the excavated area would be filled with appropriate clean backfill material and contoured to grade.

C.3.1.6.2 Removal of Remaining Floor Slabs and Foundations

The remaining floor slabs and foundations in the area, including the underground structure of the Cooling Tower, would be removed and disposed of as low-specific-activity waste, and impacted surrounding soils would be removed, as needed. As with other surface remediation areas, DCGLs would be used to determine the extent of contaminated soil removal. After completion of this work, a final status survey would be performed in each excavated area and arrangements made for any necessary independent verification surveys. RCRA confirmatory sampling would also be performed. After completion of the surveys and sampling, the excavated areas would be filled with appropriate clean backfill material and contoured to grade.

C.3.1.6.3 Estimated Waste to be Generated

The estimated waste volumes expected to be generated under the Sitewide Removal Alternative in WMA 6 are presented in **Table C–20**.

Table C–20 Estimated Waste to be Generated: Waste Management Area 6

<i>Waste Type</i>	<i>Waste Volume (cubic feet)</i>
Construction and Demolition Debris	76,000
Hazardous Waste	0
Low-level Radioactive Waste	
Low Specific Activity	42,000
Class A	100
Class B	0
Class C	0
Greater-Than-Class C Waste	0
Mixed Low-level Radioactive Waste	0
Transuranic Waste	0

Notes: The estimated waste volumes are based on commercial disposal and are presented with two significant figures. To convert cubic feet to cubic meters, multiply by 0.028317.
Source: WSMS 2009a.

C.3.1.7 Waste Management Area 7: NRC-Licensed Disposal Area and Associated Facilities

The Sitewide Removal Alternative closure approach for WMA 7 would include exhumation of all buried wastes in the NDA and removal of the Liquid Pretreatment System and the Interceptor Trench, along with the buried leachate transfer line, the former lagoon, and the remaining concrete slabs and gravel pads associated with the NDA Hardstand Staging Area. All contaminated soil, sediment, and groundwater in the area would be remediated to levels supporting unrestricted release.

A new Leachate Treatment Facility, as described in Section C.4.5, would be designed and constructed on the South Plateau near SDA Trench 14 to process the aqueous leachate in the holes and trenches in the NDA and in the trenches in the SDA. It would be capable of accepting the leachate, removing organic chemicals that might be present by biological degradation and adsorption, removing entrained solids by filtration, and removing dissolved radionuclides by ion-exchange before transferring the treated water to the Low-Level Waste Treatment Facility for final treatment and discharge.

A new Container Management Facility, as described in Section C.4.4, would be designed and constructed to process the wastes excavated from the NDA and the SDA. It would be capable of receiving the wastes in an “as excavated” form, drying them, sorting them, reducing the size of larger items, recompacting wastes that were “bulked-up” during excavation, packaging them, decontaminating the packages, classifying them, and temporarily storing them. This facility may require an RCRA treatment and storage permit because some of the excavated wastes may be mixed low-level radioactive waste.

C.3.1.7.1 Removal of Structures/Facilities

The NDA Interceptor Trench would be excavated; the excavated soil and stone would be packaged for transport off site for disposal as low-specific-activity waste.

The Leachate Transfer Line could be excavated any time after a decision is made that the Liquid Pretreatment System of the Interceptor Trench Project is not needed or would no longer be needed to support treatment of leachate from the NDA. The debris would be characterized and shipped off site for disposal as low-specific-activity waste. The filled lagoon would be excavated when the special holes surrounding it are excavated.

C.3.1.7.2 Exhumation of Nuclear Fuel Services Deep Holes

The NDA deep holes and special holes contain highly radioactive waste that would be classified as Class C low-level radioactive waste or Greater-Than-Class C waste. A confinement structure, called the NDA Environmental Enclosure, would be constructed over all waste burial holes in WMA 7 suspected of containing wastes classifiable as being greater than Class A low-level radioactive waste. Therefore, it would be constructed over the NFS deep holes, the NFS special holes, and WVDP Trenches 1 through 7. The conceptual NDA Environmental Enclosure is discussed in Section C.4.6.1.

The upper layer of weathered overburden, approximately 1.2 meters (4 feet), would be excavated. This soil would be stockpiled to be used as temporary backfill material for the excavated deep holes.

As each deep hole is being prepared for excavation, sheet piling would be driven around it to a depth of approximately 3 meters (10 feet) below the base of the planned excavation. The sheet piling would provide structural support for the surrounding till during the excavation process. A crane would then be used to position the specially designed Modular Shielded Environmental Enclosure over the sheet piling. The Modular Shielded Environmental Enclosure is further described in Section C.4.6.8.

The Modular Shielded Environmental Enclosure would be equipped with a HEPA-filtered ventilation system operated at a slight vacuum compared with the ambient atmosphere within the NDA Environmental Enclosure and serve as the primary confinement structure for excavation work. The Modular Shielded Environmental Enclosure would provide secondary confinement against airborne emissions and shield against high-radiation fields.

Excavation of the deep holes and removal of the wastes would be accomplished using a telescoping Z-mast crane system. Visibility would be provided by closed-circuit television cameras. Hoisting equipment, independent from the remotely operated crane system, would be used within the Modular Shielded Environmental Enclosure. This equipment would include a bridge, trolley, and hoist to provide three-dimensional movement of materials within the Modular Shielded Environmental Enclosure and the hole over which it is located. Using the remotely operated crane system and the Modular Shielded Environmental Enclosure hoist, all the material bounded within the sheet piling would be systematically excavated.

Soil that was backfilled over the waste would be removed, to the extent possible, using an excavation bucket. Loose soil would be removed, whenever possible, by use of a vacuuming system. As the soil is brought to the surface, it would be placed into appropriate containers. Contaminated overburden soil would be placed into lift liners and sealand containers or railcars and managed as low-specific-activity waste. Interstitial soil and soil removed from the sides of the holes would be placed into 208-liter (55-gallon) drums because subsequent assay work could determine that they are Greater-Than-Class C wastes. To prevent accumulation of any liquid water in the drums, an absorbent or cementitious material, such as calcium oxide, would be placed into the bottoms of the drums and would be intermingled with the wastes as they are placed into the drums. The drums would be remotely closed, wiped down using the master-slave manipulators, and removed from the Modular Shielded Environmental Enclosure through a sealed load-in/load-out system. The loaded drum would then be transported to the Container Management Facility for characterization, interim storage, and shipment off site for disposal.

Leachate encountered during the exhumation process would be pumped to the Leachate Treatment Facility for treatment.

Buried waste would be removed using a manipulator or grapple on the Z-mast, together with a bucket and hook on the chain hoist. The retrieved wastes would be packaged in 208-liter (55-gallon) drums before being removed from the Modular Shielded Environmental Enclosure.

Whenever exposure levels immediately outside the Modular Shielded Environmental Enclosure become greater than 50 millirem per hour, operations would be performed remotely. To keep radiation exposures as low as is reasonably achievable (ALARA), remote operation could be performed until less-intense radiation fields are encountered. Conceptually, the Control Room for the remote operations would be located in the Container Management Facility, with observation capabilities provided by closed-circuit television cameras inside the Modular Shielded Environmental Enclosure and on excavation equipment lowered into the hole or trench.

After all the waste has been retrieved from a hole, contamination on the interior surfaces of the Modular Shielded Environmental Enclosure would be removed by remote wiping or immobilized with a spray-on fixative. The Modular Shielded Environmental Enclosure would then be removed from over the hole and positioned over the next hole to be excavated. After the Modular Shielded Environmental Enclosure has been removed, the sheet piling would be extracted for reuse and some of the stockpiled weathered till would be used to temporarily backfill the hole.

C.3.1.7.3 Exhumation of Nuclear Fuel Services Special Holes

Exhumation of the NFS special holes would be done under confinement provided by the NDA Environmental Enclosure. Each special hole would be excavated under a HEPA-filter ventilated confinement structure within the NDA Environmental Enclosure. This temporary confinement structure would provide the primary confinement for the excavation work. The NDA Environmental Enclosure would provide secondary confinement. Special holes containing Greater-Than-Class C wastes would be excavated under a Modular Shielded Environmental Enclosure, as described in the preceding section for the deep holes. For those special holes that do not contain Greater-Than-Class C wastes, a tent-like containment structure would be erected over the hole or group of holes.

The upper layer of weathered overburden, approximately 1.2 meters (4 feet) in thickness, would be excavated. This soil would be placed into appropriate containers, sampled for characterization purposes, and transported to a low-level radioactive waste disposal facility for disposal as low-specific-activity waste.

The first special hole would be opened by excavating a vehicle access ramp at the end of the special hole down to the floor level of the hole. Leachate, as encountered, would be transferred to the Leachate Treatment Facility for treatment and discharge.

The first special hole or trench under the temporary confinement structure would then be excavated from the side using appropriate excavation equipment. Whenever exposure levels greater than 50 millirem per hour are encountered, remotely operated excavation equipment would be used.

Depending upon moisture content, the bucket loads of soil would be transported to the Container Management Facility to be dried or would be sampled and placed directly into appropriate containers.

The bucket loads of waste or waste commingled with soil would be placed into covered transfer boxes. The boxes would be wiped down and transported to the Container Management Facility. At the Container Management Facility, the waste would be unloaded, dried, sorted, reduced in size and volume, and packaged. The packages would be decontaminated, characterized, and prepared for shipment.

Items of waste that are too large to be handled using an excavator bucket would be unearthed as much as possible and segmented with an oxygen lance-style cutting torch. During cutting operations, a localized roughing filter and HEPA filter ventilation system would be applied to prevent spread of airborne contamination. Should the exposure levels be greater than 50 millirem per hour, segmenting would be performed remotely using an oxygen lance-style cutting torch mounted on a roving robot.

For items expected to be classified as Greater-Than-Class C waste that cannot be processed within a Modular Shielded Environmental Enclosure, the segments would be placed into 208-liter (55-gallon) drums, which would be closed, remotely wiped down using the roving robots, then transferred to the Container Management Facility, where the drums would be characterized and stored until disposition decisions are made and implemented. For other large items, such as the railroad car in Special Hole 72, the segments would be placed into appropriate containers, which would subsequently be closed, wiped down, and transferred to the Container Management Facility, where the containers would be characterized and prepared for shipment.

Leachate encountered during the excavation process would be pumped to the Leachate Treatment Facility for treatment, followed by transfer to the Low-Level Waste Treatment Facility for final treatment and discharge.

After each special hole or trench has been excavated, the wall between it and an adjacent special hole or trench would be excavated—this soil would be handled as contaminated or potentially contaminated soil. The same

access ramp would therefore be used for all special holes and trenches excavated within the temporary confinement structure.

After all the special holes under the temporary confinement structure have been excavated, the temporary confinement structure would be dismantled and then re-erected over the next series of special holes to be excavated.

C.3.1.7.4 Exhumation of West Valley Demonstration Project Burial Trenches

Because WVDP Trenches 1 through 5 contain wastes classifiable as being greater than Class A low-level radioactive waste, these trenches would be excavated under the NDA Environmental Enclosure. The configuration of the NDA Environmental Enclosure would also cover WVDP Trenches 6 and 7, which are in close proximity to Trenches 1 through 5. WVDP Trenches 8 through 12 would be excavated under a less-robust structure called the WVDP Disposal Area Environmental Enclosure, which is discussed in Section C.4.6.2.

The wastes in WVDP Trenches 1 through 7 would be exhumed in the same manner as the NFS special holes, as described in the preceding section.

After all the trenches have been excavated, the remaining surrounding till would be excavated. Anticipating that this soil would be classified as low-specific-activity waste, it was assumed to be sampled and placed into appropriate containers. The samples would be analyzed to verify and document the waste classification. All waste generated would be disposed of as described in Chapter 4, Section 4.1.11. Transuranic and Greater-Than-Class C waste volumes are shown in Table C-21.

After all the adjacent trenches have been excavated, one large excavation cavity would remain. A final status survey would be performed in this excavation before it is filled with appropriate clean backfill material. The WVDP Disposal Area Environmental Enclosure would be decontaminated and dismantled, the foundations would be demolished, and the debris would be disposed of as low-level radioactive waste.

C.3.1.7.5 Exhumation of West Valley Demonstration Project Caissons

Any leachate present in the WVDP caissons would be pumped to the Leachate Treatment Facility for treatment and discharge before any waste removal activities begin.

WVDP disposal records indicate that approximately 23 cubic meters (823 cubic feet) of waste in drums is present in Caisson 1. The disposal records do not indicate that waste was placed in Caissons 2 through 4. If possible, the drums would be removed intact using a crane and associated grappling attachment. If necessary, the waste would be removed from the caisson using a crane and an excavation bucket. As the waste is brought to the surface, the drums would be inspected. If intact, they would be overpacked and transported to the Container Management Facility for classification and shipment for disposal. If not intact, the debris and waste soil would be placed into appropriate containers, which would be closed, decontaminated, and transported to the Container Management Facility for classification and shipment for disposal. After the waste has been removed from a caisson, the floor of the caisson would be inspected using a closed-circuit television camera lowered by a crane. If waste is found to be present in Caissons 2 through 4, it would be removed and managed in a similar manner. After all the waste has been retrieved from a caisson, it would be demolished and disposed of off site as low-specific-activity waste.

C.3.1.7.6 Site Restoration

Large excavations would remain after the deep holes, special holes, trenches, and caissons have been exhumed. As a final step, all of the contaminated soil from the vicinity of the holes, as well as the cap material used for the temporary barrier, would be excavated and disposed of as low-specific-activity waste. The resulting “crater” would then be surveyed and filled. A final status survey would be performed in these excavations to verify that residual radioactivity levels do not exceed the established DCGLs. Similarly, chemical sampling would be performed to verify that all hazardous constituents are below acceptable regulatory guidance values. An independent verification survey may also be performed. After the verification survey is complete, the area would be backfilled with appropriate clean backfill material and contoured to grade.

C.3.1.7.7 Closure of Environmental Enclosures and Hydraulic Barriers

Demolition of NRC-Licensed Disposal Area Environmental Enclosure and West Valley Demonstration Project Disposal Area Environmental Enclosure

The HEPA filters from the ventilation systems of the NDA Environmental Enclosure and the WVDP Disposal Area Environmental Enclosure would be removed by bag-out procedures, wrapped in polyethylene or equivalent material, and loaded into a container as radioactive waste. The ventilation system equipment would then be selectively demolished, loaded into appropriate containers, and transferred to the Container Management Facility for characterization and shipment for disposal as low-specific-activity waste.

The interior surfaces of the NDA Environmental Enclosure and the WVDP Disposal Area Environmental Enclosure are expected to be slightly contaminated. Therefore, they would be thoroughly surveyed and a spray fixative applied, as necessary, to allow demolition of the structure without confinement. The enclosure would be manually demolished with conventional equipment such as hydraulic hammers and backhoes. The debris would be surveyed and sampled for characterization purposes, placed into appropriate containers, and then shipped off site for disposal as low-specific-activity waste.

Verification Surveys, Backfilling, and Landscaping

Once the enclosures and below-grade hydraulic barriers have been removed, any contaminated soil generated during demolition would be removed and disposed of as low-specific-activity waste. A final status survey would be performed in the area impacted by demolition of the enclosure and excavation of the NDA barrier wall to establish that residual radioactivity levels do not exceed the established DCGLs. Because there is a possibility of removing mixed low-level radioactive waste from the NDA burial areas, confirmatory soil samples would likely be collected and analyzed for constituents of concern. RCRA confirmatory sampling would also be performed. Once all the required surveys and sampling have been completed, clean soil backfill would be placed and the area graded to a near natural appearance.

C.3.1.7.8 Disposal of Equipment

The used equipment would include, among other items, the Modular Shielded Environmental Enclosures; manually and remotely operated excavators; two or more remotely operated roving robots with closed-circuit television cameras, a cutting torch, or both; and multiple overhead crane systems. This equipment would be reduced in size, boxed, and disposed of at an offsite low-level radioactive waste disposal facility.

C.3.1.7.9 Estimated Waste to be Generated

The estimated waste volumes expected to be generated under the Sitewide Removal Alternative in WMA 7 are presented in **Table C–21**. The estimate includes the construction and demolition of all structures other than the Leachate Treatment Facility and the Container Management Facility supporting the exhumation activities in WMA 7. **Table C–22** provides the estimated waste to be generated from the construction, operation, and demolition of the Leachate Treatment Facility and the Container Management Facility, which would be constructed to support the waste processing activities in the NDA and SDA.

Table C–21 Estimated Waste to be Generated: Waste Management Area 7

<i>Waste Type</i>	<i>Waste Volume (cubic feet)</i>
Construction and Demolition Debris	200,000
Hazardous Waste	0
Low-level Radioactive Waste	
Low Specific Activity	7,300,000
Class A	340,000
Class B	55,000
Class C	23,000
Greater-Than-Class C Waste	75,000
Mixed Low-level Radioactive Waste	310
Transuranic Waste	1,100

Notes: The estimated waste volumes are based on commercial disposal and are presented with two significant figures. To convert cubic feet to cubic meters, multiply by 0.028317.
Source: WSMS 2009a.

Table C–22 Estimated Waste to be Generated: Leachate Treatment Facility and Container Management Facility

<i>Waste Type</i>	<i>Waste Volume (cubic feet)</i>
Construction and Demolition Debris	150,000
Hazardous Waste	0
Low-Level Radioactive Waste	
Low Specific Activity	370,000
Class A	200,000
Class B	0
Class C	1,100
Greater Than Class C Waste	0
Mixed Low-Level Radioactive Waste	14,000
Transuranic Waste	0

Notes: The estimated waste volumes are based on commercial disposal and are presented with two significant figures. To convert cubic feet to cubic meters, multiply by 0.028317.
Source: WSMS 2009a.

C.3.1.8 Waste Management Area 8: State-Licensed Disposal Area and Associated Facilities

Removal of WMA 8 would be performed under a negotiated closure plan approved by the NYSDEC Hazardous Waste and Radiation Programs. This closure plan would satisfy RCRA closure and corrective action requirements and Radiation Program requirements under 6 NYCRR Part 380. Preparatory characterization and design work would be performed and applications would be made for the necessary regulatory approvals.

The Sitewide Removal Alternative closure approach for WMA 8 would be similar to that for the NDA. The buried waste in the SDA would be removed; the Mixed Waste Storage Facility would be removed; and all

contaminated soil, sediment, and groundwater in the area would be remediated to levels supporting unrestricted release.

A new Leachate Treatment Facility, as described in Section C.4.5, would be constructed on the South Plateau near SDA Trench 14 to process the aqueous leachate in the trenches in the SDA and in the holes and trenches in the NDA. A new Container Management Facility would be constructed, as described in Section C.4.4, on the South Plateau near the Rail Spur to process the wastes excavated from the SDA and NDA.

C.3.1.8.1 Removal of Structures/Facilities

Mixed Waste Storage Facility

Tanks T-1, T-2, and T-3 and associated equipment in the Mixed Waste Storage Facility would be reduced in size and disposed of offsite. Tank T-1 could be disposed of as either Class A low-level radioactive waste or mixed low-level radioactive waste.¹ It is assumed that Tanks T-2 and T-3 would be disposed of as construction and demolition debris because they were never used. However, these tanks may be sold or recycled. The Mixed Waste Storage Facility would be demolished with the debris packaged, characterized, and shipped offsite for disposal.

C.3.1.8.2 Exhumation of State-Licensed Disposal Area Trenches in the South Disposal Area

Removal of the SDA trenches in the South Disposal Area would include the following activities: (1) construction of an environmental enclosure over the southern SDA trenches; (2) leachate management and treatment using the Leachate Treatment Facility; (3) management, treatment, packaging, and characterization of excavated waste in the Container Management Facility; and (4) demolition and disposal of support facilities used during the removal. These activities are discussed in greater detail in the following paragraphs.

The South SDA Environmental Enclosure would be constructed over Trenches 8 through 14, which are known to contain wastes classifiable as greater than Class A low-level radioactive waste. This structure is discussed in Section C.4.6.3.

The existing fabric geomembrane, approximately 1.2 meters (4 feet) of earthen cap material, and approximately 1.2 meters (4 feet) of adjacent weathered till, would be excavated. This soil would be placed into appropriate containers, sampled for characterization purposes, and transported to a commercial low-level radioactive waste disposal facility. Generally, this material is expected to be classified as low-specific-activity waste.

A Modular Shielded Environmental Enclosure would be constructed inside the South SDA Environmental Enclosure. As each trench is being prepared for excavation, sheet piling would be driven around it to a depth of approximately 3 meters (10 feet) below the base of the planned excavation, using a drop hammer or single-acting diesel hammer. A crane would then be used to position each of the panels of the specially designed Modular Shielded Environmental Enclosure onto the sheet piling and over the trench to create the enclosure, as described in Section C.4.6.8.2.

Excavation of the trenches and removal of the wastes would be accomplished using a remotely operated Z-mast crane system. Visibility would be provided using closed-circuit television cameras. A tool appropriate for the work to be performed would be attached remotely to the excavator arm. The tools available for use would include, but would not necessarily be limited to, a standard bucket, proclain bucket, grapple, parallel jaw

¹ Tank T-1 may be removed prior to the starting point of this EIS. For purposes of analysis in this EIS, Tank T-1 is included in the inventory of low-level radioactive waste.

grippers, and shear. The standard bucket would be used, as appropriate, to remove cap and overburden material from over the trenches. The standard bucket would be used to remove loose materials from the trenches. The grapple would be used to remove objects from the trenches. The shear would be used to reduce the size of objects within the trenches to facilitate removal. The Z-mast crane would be able to extend to the bottom of the 6-meter-deep (20-foot-deep) trenches and would be able to operate effectively when the arm is fully extended.

Using the Z-mast crane, all the material bounded within the sheet piling would be systematically excavated. Material brought to the surface would be placed into appropriate containers and transferred to the Container Management Facility for processing, packaging, characterization, and transport off site.

Leachate encountered during the excavation process would be pumped to the Leachate Treatment Facility. The treated leachate would be directed to the existing Low-Level Waste Treatment Facility for final treatment and discharge at the permitted outfall from Lagoon 3 to Erdman Brook.

Because leachate is expected to have transferred some contaminants into the surrounding till, the excavations would extend both laterally to the sheet piling placed around the trench and down a short distance below the original bottom of the trench.

Whenever exposure levels immediately outside the Modular Shielded Environmental Enclosure become greater than 50 millirem per hour, operations would be performed remotely. To keep radiation exposures ALARA, remote operation would be performed until less-intense radiation fields are encountered. Conceptually, the Control Room for the remote operations would be located in the Container Management Facility, with observation capabilities provided by closed-circuit television cameras inside the Modular Shielded Environmental Enclosure and on excavation equipment lowered into the trench.

After all the waste has been retrieved from a trench, the interior surfaces of the Modular Shielded Environmental Enclosure would be decontaminated to the maximum reasonable extent by remote wiping. The Modular Shielded Environmental Enclosure would be removed from over the trench and positioned over the next trench to be excavated. After the Modular Shielded Environmental Enclosure has been removed, the sheet piling would be extracted and retained for reuse.

The soil between the trenches would be excavated and disposed of as low-specific-activity waste at a commercial low-level radioactive waste disposal facility.

The South SDA Environmental Enclosure would remain until all excavation work in the South Disposal Area has been completed.

A large excavation would exist after the waste and contaminated soil is removed from the trenches in the South Disposal Area. A final status survey would be performed in the excavation to verify that residual radioactivity levels do not exceed the established DCGLs. RCRA confirmatory sampling would also be performed. An independent verification survey may be required. Once all the required surveys and sampling have been completed, the area would be backfilled with appropriate clean backfill material and contoured to grade.

C.3.1.8.3 Exhumation of State-Licensed Disposal Area Trenches in the North Disposal Area

Similar to the process described for the SDA trenches in the South Disposal Area, a confinement structure called the North SDA Environmental Enclosure would be constructed over Trenches 1 through 7, which are known to contain wastes classifiable as greater than Class A low-level radioactive waste. The North SDA Environmental Enclosure is discussed in Section C.4.6.4.

Wastes disposed of in the northern SDA trenches would be removed in the same manner as those in the southern SDA trenches. A final status survey would be performed in the excavation. RCRA confirmatory sampling would also be performed.

The North SDA Environmental Enclosure would remain until all excavation work in the North Disposal Area has been completed.

C.3.1.8.4 Exhumation of Filled Lagoons

A pre-engineered, sheet metal confinement structure called the SDA Lagoon Environmental Enclosure would be constructed over each of the three filled lagoons, as described in Section C.4.6.5. Once the lagoons have been excavated and confirmed to be in compliance with applicable regulatory requirements, the confinement structures, which are expected to become slightly contaminated during excavation, would be dismantled and disposed of as low-specific-activity waste in a commercial low-level radioactive waste disposal facility.

The upper layer of weathered overburden over each of the three lagoons, approximately 1.2 meters (4 feet) thick, would be excavated. This soil would be placed into appropriate containers and sampled for characterization purposes. This material is expected to be low-specific-activity waste.

The fill within the filled lagoons would be excavated using a hydraulic excavator. High radiation fields are not anticipated and, for purposes of this EIS, an assumption was made that remotely operated equipment would not be needed for excavation of the filled lagoons.

After the lagoons have been excavated, the lagoon confinement structures would be sprayed with fixative and demolished. The demolition debris would be disposed of as low-specific-activity waste at a commercial low-level radioactive waste disposal facility.

After the waste material has been removed from the lagoons, any impacted material surrounding the lagoons would be removed. Additionally, once the waste material has been removed and the enclosures are deemed to be no longer necessary, demolition of the enclosures would begin. Removal of the enclosures would allow the excavation to expand beyond the limits of the enclosures if necessary. A water mist would be applied, as necessary, to prevent the generation of airborne dust. Because this soil is expected to be contaminated and classified as low-specific-activity waste, it would be placed into appropriate containers or railcars. The material would be transported to a commercial low-level radioactive waste disposal facility. As with other surface remediation areas, DCGLs would be used to determine the extent of contaminated soil removal.

C.3.1.8.5 Site Restoration

Demolition of State-Licensed Disposal Area Environmental Enclosures

The North SDA Environmental Enclosure and the South SDA Environmental Enclosure could be demolished at different times, but both would be demolished in the manner described in the following paragraphs.

The HEPA filters from the ventilation systems of the SDA Environmental Enclosures would be removed by bag-out procedures, wrapped in polyethylene or equivalent material, and loaded into an appropriate container as radioactive waste. The ventilation system equipment would then be selectively demolished, loaded into the containers, and transferred to the Container Management Facility for characterization and shipment for disposal as low-specific-activity waste at a commercial radioactive waste disposal facility.

The interior surfaces of the SDA Environmental Enclosures are expected to be slightly contaminated. Therefore, they would be thoroughly surveyed, and contamination would be spray fixed, as necessary, to allow

demolition of the structure without confinement. The environmental enclosures would be manually demolished using hydraulic excavators equipped with demolition hammers, grapples, and shear attachments. The debris would be surveyed and sampled for characterization purposes, placed into lift liners, and then shipped off site for disposal as low-specific-activity waste at a commercial low-level radioactive waste disposal facility.

Removal of the Below-Grade Walls

To restore natural groundwater flow, the below-grade concrete wall and the below-grade slurry wall would be excavated, and the excavated material would be appropriately packaged for shipment. For estimating purposes, the excavated material was assumed to be managed as low-specific-activity waste and disposed of at a commercial low-level radioactive waste disposal facility.

Once the enclosures and below-grade hydraulic barriers have been removed, any contaminated soil generated during demolition would be removed and disposed of as low-specific-activity waste. A final status survey would be performed in the area impacted by demolition of the enclosures and excavation of below-grade hydraulic barriers to establish that residual radioactivity levels do not exceed the established DCGLs. A chemical survey would also be performed to verify that all hazardous constituents are below appropriate regulatory guidance values. After the surveys are completed, additional appropriate clean backfill material would be placed and the area graded to a near natural appearance.

C.3.1.8.6 Disposal of Equipment

The used equipment would include, among other items, the Modular Shielded Environmental Enclosures, a manually operated excavator, Z-mast crane and other overhead crane systems. Items would be reduced in size, as necessary; packaged; and shipped to a commercial low-level radioactive waste disposal facility.

C.3.1.8.7 Estimated Waste to be Generated

The estimated waste volumes expected to be generated under the Sitewide Removal Alternative in WMA 8 are presented in **Table C-23**. The estimate includes the construction and demolition of all structures supporting the decommissioning activities in WMA 8 except the Leachate Treatment Facility and the Container Management Facility, which were included in the discussion of WMA 7 activities and presented in Table C-21.

Table C-23 Estimated Waste to be Generated: Waste Management Area 8

<i>Waste Type</i>	<i>Waste Volume (cubic feet)</i>
Construction and Demolition Debris	480,000
Hazardous Waste	0
Low-level Radioactive Waste	
Low Specific Activity	14,000,000
Class A	2,700,000
Class B	31,000
Class C	65,000
Greater-Than-Class C Waste	74,000
Mixed Low-level Radioactive Waste	2,500
Transuranic Waste	0

Notes: The estimated waste volumes are based on commercial disposal and are presented with two significant figures. To convert cubic feet to cubic meters, multiply by 0.028317.

Source: WSMS 2009a.

C.3.1.9 Waste Management Area 9: Radwaste Treatment System Drum Cell

C.3.1.9.1 Removal of the Radwaste Treatment System Drum Cell

The Drum Cell would be demolished by conventional means and the floor slab and foundation removed, along with the underlying gravel base. It is assumed that the demolition debris would be disposed of off site as construction and demolition debris.

After completion of this work, a final status survey would be performed in the excavated area and arrangements made for any necessary independent verification surveys. RCRA confirmatory sampling would also be performed. After completion of the surveys and sampling, the excavated area would be filled with appropriate clean backfill material, and contoured to grade.

C.3.1.9.2 Removal of the Subcontractor Maintenance Area and Gravel Pads

The subcontractor trailers would be demolished using standard means and methods. The demolition debris and gravel pad would be managed as construction and demolition debris.

In addition, the NDA Trench Soil Container Area’s gravel pad would be removed. This pad is assumed to have been contaminated during its operational period and would be processed as low-specific-activity waste. As with other surface remediation areas, DCGLs would be used to determine the extent of contaminated soil removal.

C.3.1.9.3 Estimated Waste to be Generated

The estimated waste volumes expected to be generated under the Sitewide Removal Alternative in WMA 9 are presented in **Table C–24**.

Table C–24 Estimated Waste to be Generated: Waste Management Area 9

<i>Waste Type</i>	<i>Waste Volume (cubic feet)</i>
Construction and Demolition Debris	250,000
Hazardous Waste	0
Low-level Radioactive Waste	
Low Specific Activity	56,000
Class A	100
Class B	0
Class C	0
Greater-Than-Class C Waste	0
Mixed Low-level Radioactive Waste	0
Transuranic Waste	0

Notes: The estimated waste volumes are based on commercial disposal and are presented with two significant figures. To convert cubic feet to cubic meters, multiply by 0.028317.

Source: WSMS 2009a.

C.3.1.10 Waste Management Area 10: Support and Services Area

The Sitewide Removal Alternative closure approach for WMA 10 is demolition and removal of existing facilities, along with the remaining concrete floor slabs and foundations. Any contaminated soil, sediment, and groundwater in the area would be remediated to levels supporting unrestricted release.

C.3.1.10.1 Removal of Structures/Facilities

The New Warehouse (including the former Waste Management Staging Area), Meteorological Tower, Security Gatehouse and security fences would be demolished and the debris would be disposed of off site as uncontaminated construction and demolition debris.

The remaining floor slabs and foundations in the area, including those for the Administration Building, Expanded Environmental Laboratory, Construction and Fabrication Shop, and Vitrification Diesel Fuel Oil Storage Tank and Building would be removed. After completion of this work, a final status survey would be performed in each excavated area and arrangements made for any necessary independent verification surveys. RCRA confirmatory sampling would also be performed. After completion of the surveys and sampling, the excavated areas would be filled with appropriate clean backfill material and contoured to grade.

C.3.1.10.2 Estimated Waste to be Generated

The estimated waste volumes expected to be generated under the Sitewide Removal Alternative in WMA 10 are presented in **Table C–25**.

Table C–25 Estimated Waste to be Generated: Waste Management Area 10

<i>Waste Type</i>	<i>Waste Volume (cubic feet)</i>
Construction and Demolition Debris	96,000
Hazardous Waste	0
Low-level Radioactive Waste	
Low Specific Activity	0
Class A	0
Class B	0
Class C	0
Greater-Than-Class C Waste	0
Mixed Low-level Radioactive Waste	0
Transuranic Waste	0

Notes: The estimated waste volumes are based on commercial disposal and are presented with two significant figures. To convert cubic feet to cubic meters, multiply by 0.028317.
Source: WSMS 2009a.

C.3.1.11 Waste Management Area 11: Bulk Storage Warehouse and Hydrofracture Test Well Area

Under the Sitewide Removal Alternative, the Scrap Material Landfill would be excavated. Any contaminated soil, sediment, and groundwater would be remediated to levels supporting unrestricted release.

C.3.1.11.1 Removal of Structures/Facilities

Scrap Material Landfill

The overburden above the Scrap Material Landfill would be excavated and staged nearby. The contents of the Scrap Material Landfill would be exhumed and disposed of as construction and demolition debris at an offsite disposal facility. The excavation would be filled with appropriate clean backfill material, after which the overburden material that had been removed would be replaced over the top.

Although no radioactive contamination is expected, once closure activities have been completed, a final status survey would be performed to verify that residual radioactivity levels do not exceed the established DCGLs.

An independent verification survey may also be required. After the verification survey is complete, the area would be filled with appropriate clean backfill material and graded, as necessary, to restore it to a near natural appearance.

C.3.1.11.2 Estimated Waste to be Generated

The estimated waste volumes expected to be generated under the Sitewide Removal Alternative in WMA 11 are presented in **Table C–26**.

Table C–26 Estimated Waste to be Generated: Waste Management Area 11

<i>Waste Type</i>	<i>Waste Volume (cubic feet)</i>
Construction and Demolition Debris	33,000
Hazardous Waste	0
Low-level Radioactive Waste	
Low Specific Activity	0
Class A	0
Class B	0
Class C	0
Greater-Than-Class C Waste	0
Mixed Low-level Radioactive Waste	0
Transuranic Waste	0

Notes: The estimated waste volumes are based on commercial disposal and are presented with two significant figures. To convert cubic feet to cubic meters, multiply by 0.028317.

Source: WSMS 2009a.

C.3.1.12 Waste Management Area 12: Balance of Site

Under the Sitewide Removal Alternative, the dams and reservoirs and parking lots and roadways would be removed. Contaminated soil across the Project Premises would be removed, as necessary, to achieve levels supporting unrestricted release. In addition, contaminated stream sediments would be removed to levels supporting unrestricted release.

C.3.1.12.1 Dams and Reservoirs

The dams and reservoirs would be removed in accordance with applicable Federal and state regulations and approvals from NYSDEC, the New York State Department of Health, and the U.S. Environmental Protection Agency. The North and South Reservoirs would be drained slowly to prevent unnecessary disturbance of sediment downstream. After the water level has been lowered, the control building, pumphouse, and pipe would be demolished, and the resulting debris would be sent to an offsite disposal facility.

Dam 1 would be excavated first. An excavator would be used to excavate the soil and load it into dump trucks for transport over Dam 2 to a nearby laydown location. Dam 2 would then be excavated, and the soil would be transported to the same laydown location. The soil may be made available for use as appropriate clean backfill material in support of closure of other WMAs, but it is assumed that it will be managed as construction and demolition debris.

The steel bridge that spans across Reservoir 2 and the bridge crossing the South Reservoir would be removed. The bridges would be sectioned using a cutting torch, and the sections would be collected and disposed of as construction and demolition debris.

C.3.1.12.2 Parking Lots and Roadways

The parking lots and roadways associated with the Project Premises would be removed.

Because the parking lots and roadways were never suspected of radiological or chemical contamination, and no such materials were handled in these areas, final status surveys would not be necessary. Visual inspections to confirm the removal of all areas would serve as the primary confirmation that decommissioning requirements have been met.

C.3.1.12.3 Railroad Spurs

The Railroad Spur would be dismantled and removed. The length of the spur to be removed is approximately 2,000 meters (6,500 feet). The removed rail ties, tracks and track ballast would be disposed of as construction and demolition debris in accordance with Article 27, Title 25 of New York State Law.

C.3.1.12.4 Remediation of Surface Soil and Sediment

Surface soil and sediment with radionuclide concentrations in excess of DCGLs would be remediated during closure activities.

Available data on radioactive contamination in surface soil and sediment and additional data from the characterization program would be evaluated, considering DCGLs for surface soil and sediment. Soil and sediment with radioactivity concentrations exceeding DCGLs would be removed and disposed of off site as low-specific-activity waste. Final status surveys would be performed in areas where impacted soil or sediment was removed. RCRA confirmatory sampling would also be performed.

Because the available data on surface soil contamination are limited, estimates of the amounts of contaminated soil to be removed in different WMAs are based on the size of the posted soil radiation areas within those WMAs. Estimates for the volume of contaminated sediment to be removed are based on available radiation levels and radioactivity concentration data.

C.3.1.12.5 Remediation of Streambed Sediments

Streambed sediment in Erdman Brook and in Franks Creek between the Lagoon 3 outfall and the confluence of Franks Creek and Quarry Creek inside and outside the Project Premises fence would be remediated to DCGLs. Planning for removal of contaminated sediment would be based on consideration of available sediment data and additional data collected during the characterization program.

A process such as the following would be used:

- An access route for heavy excavation equipment would be established by removing selected trees between the road that passes Lagoon 3 and Erdman Brook; removing vegetation, as necessary; and placing gravel to provide support for the equipment.
- Streamflow would be temporarily diverted to bypass sections of streambeds to be excavated.
- Runoff controls would be installed to prevent the migration of disturbed sediment downstream of the excavation.
- An excavator would be used to remove contaminated sediment. If necessary, cranes would be used to move the material from the streambed to the plateau surface.

- Sediments would be transferred to the Soil Drying Facility (see Section C.4.3).
- The sediment would be placed in appropriate containers, which would be shipped off site for disposal as low-specific-activity waste.
- Subsequent to excavation, radiological remedial action surveys would be performed in the streambeds; additional sediment would be removed, as necessary; and a final status survey would be performed. A RCRA confirmatory status survey would also be performed.

For estimating purposes, it was assumed that streambed sediment would be removed from Erdman Brook and Franks Creek between the Lagoon 3 outfall and the confluence of Franks Creek and Quarry Creek.

C.3.1.12.6 Other Potentially Contaminated Areas

The areas identified in Section C.2.12.5 are known or believed to contain low levels of contamination. They would also be excavated and processed. As with other surface remediation areas, DCGLs would be used to determine the extent of contaminated soil removal.

C.3.1.12.7 Estimated Waste to be Generated

The estimated waste volumes expected to be generated under the Sitewide Removal Alternative in WMA 12 are presented in **Table C–27**. The estimate includes existing facility maintenance.

Table C–27 Estimated Waste to be Generated: Waste Management Area 12

<i>Waste Type</i>	<i>Waste Volume (cubic feet)</i>
Construction and Demolition Debris	2,600,000
Hazardous Waste	450
Low-level Radioactive Waste	
Low Specific Activity	250,000
Class A	180,000
Class B	0
Class C	0
Greater-Than-Class C Waste	0
Mixed Low-level Radioactive Waste	0
Transuranic Waste	0

Notes: The estimated waste volumes are based on commercial disposal and are presented with two significant figures. To convert cubic feet to cubic meters, multiply by 0.028317.

Source: WSMS 2009a.

C.3.1.13 North Plateau Groundwater Plume

C.3.1.13.1 Excavation of North Plateau Groundwater Plume

Decommissioning activities associated with the source area of the North Plateau Groundwater Plume are described in Section C.3.1.1.8. Soil and water within the nonsource area of the North Plateau Groundwater Plume would be removed to levels allowing for unrestricted use of the North Plateau area. To achieve this, the 10-picocuries-per-liter gross beta isopleth has been used to define the area of excavation. The vertical boundary is based on the depth of the Lavery till. The excavation would include the following steps: (1) install a curtain of sheet pilings around the perimeter of the plume beyond the 10-picocurie-per-liter isopleth; (2) remove and treat the contaminated groundwater to the extent feasible; (3) place a cover over the area not being actively excavated to minimize infiltration; (4) excavate the soil down to a depth of at least

0.3 meters (1 foot) into the Lavery till; and (5) process the soil, as needed, in the Soil Drying Facility and package it for disposal as low-level radioactive waste. As with other surface remediation areas, DCGLs would be used to determine the extent of contaminated soil removal.

After the source(s) of contamination are removed, the Groundwater Recovery System, pilot-scale permeable treatment wall, and full scale permeable treatment wall would be removed and a final status survey would be performed to verify that residual radioactivity levels do not exceed the established DCGLs. A RCRA confirmatory status survey would also be performed. An independent verification survey may be required. After the surveys are complete, the area would be filled with appropriate clean backfill material and graded, as necessary, to restore it to a near natural appearance.

The Soil Drying Facility would be demolished and removed after all site soil is processed. Additional remediation and closeout activities include (1) the demolition by conventional methods of the paved waste and railcar/staging areas, with the resulting debris managed as low-specific-activity waste; (2) decontamination of the skid-mounted treatment system, as necessary, and return of the system to the vendor for recycling or reuse; (3) packaging of spent ion-exchange media to be sent off site for disposal as Class B low-level radioactive waste; and (4) removal of the perimeter fencing (used to control access to the remediation site) and disposal off site as construction debris.

C.3.1.13.2 Estimated Waste to be Generated

The estimated waste volumes expected to be generated under the Sitewide Removal Alternative for the management of the nonsource area of the North Plateau Groundwater Plume are presented in **Table C–28**. The estimate also includes waste from the construction, operation, and demolition of the Soil Drying Facility. The estimated waste to be generated from the source area of the North Plateau Groundwater Plume is included within the estimate for the closure of WMA 1, shown in Table C–15.

**Table C–28 Estimated Waste to be Generated: North Plateau Groundwater
Plume (nonsource area)**

<i>Waste Type</i>	<i>Waste Volume (cubic feet)</i>
Construction and Demolition Debris	73,000
Hazardous Waste	0
Low-level Radioactive Waste	
Low Specific Activity	15,000,000
Class A	26,000
Class B	820
Class C	0
Greater-Than-Class C Waste	0
Mixed Low-level Radioactive Waste	0
Transuranic Waste	0

Notes: The estimated waste volumes are based on commercial disposal and are presented with two significant figures. To convert cubic feet to cubic meters, multiply by 0.028317.
Source: WSMS 2009a.

C.3.1.14 Cesium Prong

Areas of the Cesium Prong within and outside of WNYNSC exceeding DCGLs for unrestricted release would be excavated typically to a depth of about 15.2 centimeters (6 inches). The excavated material would be packaged into appropriate containers and transported as low-specific-activity waste to an offsite low-level radioactive waste disposal facility. Based on the shallow excavation depth, it is assumed that the excavated soil would meet the soil moisture requirements of the designated waste disposal facility. In the unlikely event

that some of the soil exceeds soil moisture requirements, it would be left to dry or sorbent material would be added.

After the source(s) of contamination are removed, a final status survey would be performed in the Cesium Prong to verify that residual radioactivity levels do not exceed the established DCGLs. RCRA confirmatory sampling would also be performed. An independent verification survey may be required. After the surveys and sampling are complete, the area would be filled with appropriate clean backfill material and graded, as necessary, to restore it to a near natural appearance.

The estimated waste volumes expected to be generated under the Sitewide Removal Alternative for the management of the Cesium Prong are presented in **Table C–29**.

Table C–29 Estimated Waste to be Generated: Cesium Prong

<i>Waste Type</i>	<i>Waste Volume (cubic feet)</i>
Construction and Demolition Debris	0
Hazardous Waste	0
Low-level Radioactive Waste	
Low Specific Activity	2,100,000
Class A	7,000
Class B	0
Class C	0
Greater-Than-Class C Waste	0
Mixed Low-level Radioactive Waste	0
Transuranic Waste	0

Notes: The estimated waste volumes are based on commercial disposal and are presented with two significant figures. To convert cubic feet to cubic meters, multiply by 0.028317.

Source: WSMS 2009a.

C.3.1.15 Removal of Environmental Monitoring Equipment

Preparation and planning for removal of the onsite and offsite environmental monitoring equipment and groundwater monitoring wells would include the following activities:

- Obtain regulator approval, as appropriate.
- Secure the required work permits, land access agreements, transportation and disposal manifests, and other documentation.
- Conduct radiological screening of the structures to ensure that the workers and the environment are appropriately protected.
- Notify the appropriate utility companies (e.g., electric, telephone/instrumentation) of discontinued power needs.

C.3.1.15.1 Demolition of Monitoring Structures

The air and surface water monitoring stations are all assumed to consist of a prefabricated fiberglass or plastic shelter that contains sampling equipment, electrical service, instrumentation systems, and other ancillary items. The equipment shelters sit on a concrete pad.

Demolition would begin with removal of the electrical service and instrument wiring. All aboveground structures and equipment remaining would then be removed and reduced in size by hand using hand tools and

portable demolition saws. Crew productivity is estimated to be approximately one structure per day. The demolished monitoring equipment would be disposed of as construction and demolition debris. Concrete pads would be removed and disposed of as construction and demolition debris. The estimated waste volumes to be generated from these activities are included in the estimate for WMA 12, shown in Table C-27.

C.3.1.15.2 Groundwater Well Removal

Following excavation of the North Plateau Groundwater Plume, NDA, and SDA and the remainder of the excavation projects involved with the Sitewide Removal Alternative, all remaining groundwater monitoring wells would be removed using overdrilling and borehole grouting techniques. The overdrilling would be done using a hollow-stem auger drill rig. Once the wells are removed, the boreholes would be filled with a nonshrink, cement-bentonite grout.

C.3.2 Sitewide Close-In-Place Alternative

Under the Sitewide Close-In-Place Alternative, the major facilities would be closed in place. The residual radioactivity in facilities involving long-lived radionuclides would be isolated using specially designed closure structures and engineered barriers (e.g., an engineered rubble pile that would contain rubble from demolition of the Main Plant Process Building). A small number of aboveground structures, such as the Lag Storage Area 4 and the Remote-Handled Waste Facility in WMA 5 and the Low-Level Waste Treatment Facility in WMA 2, would be torn down to the concrete pads to eliminate maintenance costs, and the demolition debris would be shipped off site. The waste classification and disposal facilities anticipated for final disposition of these materials would be the same as those described for the Sitewide Removal Alternative, discussed in Section C.3.1. Nearly all of the debris in WMAs 1, 3, 7, and 8 would remain on site and be covered by several caps. Activities affecting each WMA are discussed in further detail in the following subsections.

This decommissioning approach would allow large portions of WNYNSC to be released for unrestricted use. The remaining portions of WNYNSC could remain under long-term license or permit. It is also conceivable that the NRC-regulated portion of WNYNSC could have its license terminated under restricted conditions.

Unless otherwise noted, information presented in Section C.3.2 is from the *Sitewide Close-In-Place Alternative Technical Report* (WSMS 2009b).

C.3.2.1 Waste Management Area 1: Main Plant Process Building and Vitrification Facility Area

Under the Sitewide Close-In-Place Alternative, the high-level radioactive waste canisters stored in the Main Plant Process Building would be relocated. All structures within WMA 1 would be demolished to grade level. The demolition debris of the above-grade portions of the structures would be used as backfill for the underground portions of the Main Plant Process Building and the Vitrification Facility. The backfilled below-grade portions of the Main Plant Process Building, Vitrification Facility, and North Plateau Groundwater Plume source area would all be closed in an integrated manner with the Waste Tank Farm (WMA 3) within a common hydraulic barrier and beneath a common multi-layer cap. The underground storage tanks, underground lines, and Off-Gas Trench would remain in place.

C.3.2.1.1 Relocation of the High-Level Radioactive Waste Canisters

The high-level radioactive waste canisters would be relocated from the Main Plant Process Building to a new Interim Storage Facility (Dry Cask Storage Area). The activities associated with the high-level waste canister removal are the same as those that would occur under the Sitewide Removal Alternative, discussed in Section C.3.1.1.1.

C.3.2.1.2 Approach to Facility Demolition

All structures within WMA 1 would be removed to grade level. The general approach to demolition would be as follows:

- Tanks 35104, 15D-6, and 7D-13 would be filled with grout.
- Underground process lines would be filled with grout or flowable fill and left in place, contained within the circumferential hydraulic barrier wall around WMA 1 and WMA 3 (see Section C.4.8).
- Removal of the equipment and piping from the Fire Pumphouse and demolition of the superstructure itself would be accomplished by conventional methods. The Water Storage Tank would be drained, segmented using conventional cutting equipment, and placed within the area to be covered by the multi-layered, engineered cap.
- The transformer within the electrical substation would be disconnected and removed by the electrical utility company, and the remaining structure and foundation would be demolished. The demolition debris would be placed within the area to be covered by the multi-layered, engineered cap. Waste oil removed from the transformers would be characterized as hazardous waste and would be disposed of at an appropriately licensed facility. In addition, the bulk oil storage tank would be disposed of off site as construction and demolition debris.
- The Main Plant Process Building, 01-14 Building, Utility Room, Utility Room Expansion, and Plant Office Building would be demolished down to their concrete floor slabs, and the debris and pieces of remaining equipment would be placed within the subgrade portions of cells of the Main Plant Process Building or retained for the engineered rubble pile. Because the roof over the Main Plant Process Building is expected to be classified as asbestos-containing material, the waste generated from roof removal would be disposed of off site at a disposal facility licensed to accept asbestos-containing material. It is likely that the waste would be disposed of at a local sanitary landfill.
- The Vitrification Facility and the Load-In/Load-Out Facility would be demolished to their concrete floor slabs in conjunction with demolition of the Main Plant Process Building, and the debris would be placed within the melter pit or subgrade portions of the building or retained for the engineered rubble pile.
- A concrete crusher would be employed to reduce the size of large pieces of concrete rubble to make them suitable for filling subgrade portions of the Main Plant Process Building and Vitrification Facility and for creating the engineered rubble pile. Diamond-wire saw cutting would also be employed, and the blocks of concrete debris would be prescriptively placed into the subgrade facilities.
- A vertical subsurface circumferential hydraulic barrier wall would be constructed around WMA 1 and WMA 3. The structure would be a soil-bentonite barrier wall extending to sufficient depth to position it at least 1 meter (3 feet) into the unweathered Lavery till. This barrier wall would be constructed to channel groundwater around the closed facilities and help minimize the possibility of an excessive hydraulic head developing within the closed facilities. A second chevron-shaped hydraulic barrier wall would be located upgradient of the closed facilities to prevent mounding of groundwater against the circumferential barrier wall.
- A multi-layer closure cap would be constructed over the closed facilities to minimize infiltration of precipitation into the stabilized facilities. The lateral limits of the closure cap would extend over both the chevron-shaped and circumferential barrier walls. The edge of the cap would be bounded by a rock apron and a circumferential ring of large boulders.

The same hydraulic barriers and engineered cap would also enclose and cover the Waste Tank Farm in WMA 3. The hydraulic barriers and engineered cap are discussed in Section C.4.8.

C.3.2.1.3 Demolition of Main Plant Process Building

For demolition purposes, portions of the aboveground Main Plant Process Building would be divided into four categories based upon design, construction, and location: (1) the plant stack, (2) framework cells, (3) reinforced concrete framework cells, and (4) tower cells. Demolition of the Main Plant Process Building would also follow this general sequence. The general arrangement of the building was discussed in Section C.3.1.1.2.

The Main Plant Process Building contains 32 lead glass viewing windows, which together contain approximately 10,000 kilograms (22,000 pounds) of lead in their frames. These viewing windows would be removed before demolition of the building begins and would likely be managed as hazardous waste.

Removal of the Plant Stack and Remaining Equipment

The plant stack is located on the roof of the Main Plant Process Building. It would be removed before demolition of the building itself is started. The stack would be removed in sections, and the pieces would be lowered to the ground by crane, where they would be segmented, as necessary, for handling purposes and placed within an underground building cavity such as the Fuel Storage Pool.

Prior to demolition, the remaining equipment, including piping and vessels, would be removed. Some of this material has the potential for being transuranic waste.

Demolition of the Framework Cells

The framework cells were designed and constructed with masonry or concrete walls, floors, and ceilings that are supported by a structural steel framework. The walls of the framework cells are constructed from concrete block, and the floors are concrete on steel decking.

During demolition of the framework cells, asphalt roofing material, some of which contains asbestos, would be removed first using small skid steer loaders and handheld equipment. Asbestos-containing material would be identified and disposed of offsite as asbestos-containing waste.

The steel roof decking underlying the asphalt roofing would be removed and reduced in size with a mobile shear attached to a hydraulic demolition machine. The shear attachment could cut through the roof decking and reduce the size of this material, which would be disposed of off site as low-specific-activity waste.

The masonry and concrete walls in the framework cells would be demolished using the demolition machine equipped with either a shear or a demolition hammer operated under a fog spray. The hammer would break through the concrete, and the shear would be used to cut through the steel reinforcement in the concrete, as well as the steel members comprising the skeleton of these cells. A skid steer loader would be used to place rubble into the transfer boxes, which would be lowered to ground level using a crane. The demolition debris would be placed within a building cavity or staged for incorporation into the engineered rubble pile.

Demolition of the Reinforced Concrete Framework Cells

The reinforced concrete framework cells were constructed using reinforced high-density concrete up to 1 meter (3 feet) thick to provide radiation shielding while highly radioactive samples were being analyzed within them.

These cells are situated within and above framework cells of the Main Plant Process Building, and they would be demolished in conjunction with those cells.

The reinforced concrete framework cells include Analytical Cells 1 through 5, the Sample Cell, and the Sample Storage Cell, which are located at a plant elevation of 40 meters (131 feet). These cells would be demolished using demolition machines. A skid steer loader would place the demolition debris into transfer boxes, which would be lowered to ground level with a crane. This demolition debris would also be placed within a building cavity or staged for incorporation into the engineered rubble pile.

Demolition of the Tower Cells

The tower cells are constructed entirely of reinforced concrete. Their construction would allow these cells to be freestanding structures if they were physically segregated from other portions of the Main Plant Process Building. The walls, floors, and ceilings of these cells typically consist of either high-density or standard density reinforced concrete that is up to 1.7 meters (5.5 feet) thick.

The tower cells would be demolished in a controlled manner by segmenting the walls and ceilings using diamond-wire saws. The first step in the demolition of the tower cells would be segmentation and removal of the ceilings.

A series of holes would be drilled through the ceiling through which the diamond wire would be passed and to which lifting bales would be attached. The diamond wire would cut through the concrete and any rebar or pipe penetrations. The ceiling segments would be supported from above by a crane that would lift and remove the ceiling segment when cut.

The walls would be segmented in a similar fashion using diamond-wire cutting. The ceiling and wall segments would be placed directly into the subgrade facilities, reduced into small pieces and placed within a building cavity, or staged for incorporation into the engineered rubble pile.

C.3.2.1.4 Demolition of the Vitrification Facility

The Vitrification Facility would be demolished to grade level using methods such as those described for the Main Plant Process Building. Considering the construction of the building, the steel frame and sheet metal part of the structure would be demolished first, followed by the reinforced concrete Vitrification Cell.

The thick reinforced concrete walls and roof components would be segmented, as necessary, using a technique such as diamond-wire cutting. The steel shield doors would also be segmented, as necessary, for disposal, after removing them from the building if that would be more efficient.

All demolition waste would be placed in the melter pit or staged in the area for incorporation into the engineered rubble pile.

Removal of the concrete building structure would involve use of methods similar to those used with the Main Plant Process Building. This demolition debris would be placed within a Main Plant Process Building cavity or staged for incorporation into the engineered rubble pile.

C.3.2.1.5 Demolition of 01-14 Building

Demolition of the 01-14 Building would occur as described in Section C.3.1.1.4 except that the debris would be included in the rubble pile under the cover.

C.3.2.1.6 Demolition of the Load-Out Facility

The Load-Out Facility (converted from Load-In/Load-Out Facility) would be demolished once all of the high-level radioactive waste canisters have been removed from the Main Plant Process Building. The shielded transfer cell, canister handling system, high-capacity crane, and other equipment would be dismantled, removed, and included in the rubble pile under the cover.

A characterization survey would be performed to quantify the contamination and radiation fields in various parts of the building, and a spray fixative would be applied to the interior surfaces of the building. All of the identified utilities would be isolated, and all the drains and sumps would be sealed.

Standard construction equipment would be used to demolish the Load-Out Facility because the internal wall surfaces of the structure are not expected to be contaminated. The building and slab would be demolished using an excavator equipped with shear, grapple, and hammer attachments. All demolition debris would be included in the rubble pile under the cover.

C.3.2.1.7 Demolition of the Other Waste Management Area 1 Structures

The Utility Room, Utility Room Expansion, and Plant Office Building are relatively simple structures that would be demolished to grade using conventional demolition equipment at an appropriate point in the Main Plant Process Building demolition sequence. The rubble would be placed in an underground part of the building or staged for incorporation into the engineered rubble pile.

Equipment and piping in the Fire Pumphouse would be removed if deemed valuable in terms of reuse or recycling. Then the Fire Pumphouse would be demolished by conventional methods, and the demolition debris would be incorporated into the engineered rubble pile.

The Water Storage Tank would be drained and the water released to the storm sewer in accordance with appropriate SPDES permits. The steel tank would then be segmented using conventional steel cutting equipment, such as acetylene torches. Although the tank segments might be recycled, they are conservatively assumed to be added to the engineered rubble pile and thus disposed of on site.

The Electrical Substation and the bulk oil storage tank would be both drained of oil, and the oils would be handled according to applicable regulations. The transformer oils are assumed to be characterized as hazardous waste due to PCB concentrations. The fuel oil from the tank is expected to be recycled or reused without disposal costs.

Once the bulk oil storage tanks are empty, they would be segmented, as appropriate, and removed from the site for offsite disposal. The tanks are assumed to be classified as clean construction and demolition debris and would be disposed of at a local sanitary landfill or construction and demolition debris landfill.

C.3.2.1.8 Placement of Building Rubble

The debris from demolition of the aboveground portions of the Main Plant Process Building and other WMA 1 structures would be placed within the underground areas of the building to the extent practicable. These areas would be completely filled with debris.

The total volume of the underground portions of the Main Plant Process Building and the Vitrification Facility available for demolition debris is approximately 5,000 cubic meters (175,000 cubic feet), with approximately 3,400 cubic meters (120,000 cubic feet) of this amount in the Fuel Receiving and Storage Area. The estimated

volume of rubble from demolition of the above-grade portions of the Main Plant Process Building and Vitrification Facility is approximately 14,000 cubic meters (500,000 cubic feet).

Some underground areas, such as the three areas in the Fuel Receiving and Storage Area, melter pit, soaking pit, and Liquid Waste Cell, have the advantage of being readily accessible. Others have thick reinforced concrete ceilings that form part of the ground floor of the Main Plant Process Building.

The general process for establishing a building rubble pile would include steps such as the following:

- Placing rubble into the Fuel Storage Pool, Cask Unloading Pool, and Water Treatment Area until these spaces are filled to grade level
- Placing rubble into other areas that do not have grade-level ceilings such as the melter pit, soaking pit, and Liquid Waste Cell until these spaces are filled to grade level
- Demolishing the ceilings (the grade-level floor slabs) above areas such as the General Purpose Cell, General Purpose Cell Crane Room, the Miniature Cell, and the General Purpose Cell Crane Room Extension and filling these spaces with rubble
- Spreading the remaining rubble, approximately 9,000 cubic meters (325,000 cubic feet) evenly over the WMA 1 area, which would produce an average pile height of approximately 1 meter (3 feet)

C.3.2.1.9 Installation of the Circumferential Hydraulic Barrier Wall and the Closure Cap

The WMA 1 and WMA 3 hydraulic barrier wall and the closure cap would be installed after completing preparations to close the Waste Tank Farm and after receiving regulatory approval. The hydraulic barrier wall and multi-layer cap are discussed in Sections C.3.2.3.8 and C.4.8.

C.3.2.1.10 Estimated Waste to be Generated

The estimated waste volumes expected to be generated under the Sitewide Close-In-Place Alternative in WMA 1 are presented in **Table C–30**. The estimate includes the modification of the Load-In/Load-Out Facility and the operation and demolition of the Interim Storage Facility (Dry Cask Storage Area) associated with the high-level waste canister removal.

Table C–30 Estimated Waste to be Generated: Waste Management Area 1

<i>Waste Type</i>	<i>Waste Volume (cubic feet)</i>
Construction and Demolition Debris	210,000
Hazardous Waste	83
Low-level Radioactive Waste	
Low Specific Activity	39,000
Class A	46,000
Class B	0
Class C	0
Greater-Than-Class C Waste	0
Mixed Low-level Radioactive Waste	1,400
Transuranic Waste	0

Notes: The estimated waste volumes are based on commercial disposal and are presented with two significant figures. To convert cubic feet to cubic meters, multiply by 0.028317.
Source: WSMS 2009b.

C.3.2.2 Waste Management Area 2: Low-Level Waste Treatment Facility Area

The approach to closing WMA 2 under the Sitewide Close-In-Place Alternative involves stabilization and enclosing Lagoon 1 within a vertical hydraulic barrier wall; stabilizing and then filling Lagoons 2 and 3 with compacted earth; removing the membrane liners and underlying berms from Lagoons 4 and 5; regrading the area so that no perched water can form, and then covering the area of all five lagoons with a multi-layer cover. The permeable treatment wall installed across the nonsource area of the North Plateau Groundwater Plume for the starting point of the EIS would be periodically replaced. Other activities in WMA 2 include backfilling the Neutralization Pit and the interceptors after breaking up their bottoms and removing the Low-Level Waste Treatment Facility to grade.

C.3.2.2.1 Removal of Structures/Facilities

The closure of WMA 2 facilities would be coordinated to facilitate removal of the water in the Neutralization Pit and the interceptors and transfer of the water to the Low-Level Waste Treatment Facility for processing before the Low-Level Waste Treatment Facility and the lagoons would be taken out of service. The lagoons would be closed in a sequence that would permit discharge of the water through the permitted outfall to Erdman Brook. Decommissioning activities associated with the Low-Level Waste Treatment Facility, Neutralization Pit, and Old and New Interceptors are described in the following paragraphs. No action would be taken on the Solvent Dike, Maintenance Shop Leach Field, Fire Brigade Training Area, or the remaining floor slabs and foundations.

Low-Level Waste Treatment Facility

The contents of skid-mounted wastewater processing modules (ion-exchange media and activated carbon) would be flushed to the waste packaging area, where they would be packaged for transport off site and disposal as low-specific-activity waste. The wastewater processing equipment and piping from the building would be removed and reduced in size, as appropriate; packaged; placed into appropriate containers; and transported off site for disposal as low-specific-activity waste.

The waste packaging area would be demolished to its floor slab using appropriate controls such as fog spray, and the sump liner would be removed. The resulting debris would be packaged for disposal off site as low-specific-activity waste. The remainder of the Low-Level Waste Treatment Facility would then be demolished to its floor slab by conventional methods without confinement, and the resulting debris would be handled as low-specific-activity waste, placed into appropriate containers, and transported off site for disposal.

A final status survey would be performed on the remaining floor slab and in the sump cavity, and arrangements would be made for any necessary independent verification surveys. After the surveys have been completed, the sump cavity would be filled with appropriate clean backfill material.

Neutralization Pit

The water in the pit would be pumped out. A final status survey of the pit would be performed, and arrangements would be made for any necessary independent verification surveys. After the surveys have been completed, the bottom of the pit would be broken up to prevent water retention, and it would be backfilled with appropriate clean backfill material.

New and Old Interceptors

The New and Old Interceptor roofs would be removed from the subsurface structures, demolished, and packed in containers for disposal. The roof debris is expected to be managed as low-specific-activity waste. The

subsurface structures would be demolished in place by using an excavator with a hydraulic hammer to punch holes in the liner (if present) and concrete walls/base, minimizing the potential for water to become trapped within the subsurface structure. Because the Old Interceptor concrete floor is expected to have high levels of residual contamination between layers of concrete, the floor would not be demolished. Rather, the concrete walls above the floor surface would be penetrated to ensure trapped water is minimized. The vaults would then be filled with appropriate clean backfill material. During backfilling, other remaining depressions, such as the Neutralization Pit, would also be filled with appropriate clean backfill material.

Wastewater pipelines in the vicinity of the interceptors would be excavated, severed, and plugged with grout. The excavations would be performed immediately outside of the interceptors, and no waste would be generated. Grouting of the pipelines is intended to minimize the preferential groundwater flow through inactive sewers, pipes, and other conduits.

C.3.2.2.2 Decommissioning of the Lagoons

A common engineered multi-layer cover would be installed over Lagoons 1, 2, 3, 4, and 5 as part of the Sitewide Close-In-Place Alternative. The cover is discussed in Section C.4.9. It is assumed that the lagoons would be dewatered prior to the start of work. As part of the cover installation, the sediments of Lagoons 1 and 2 would be stabilized, and a circumferential barrier wall would be placed around Lagoon 1.

Lagoon 1 Sediment Stabilization

It is assumed that approximately 1.5 meters (5 feet) of sediment and debris would be stabilized in Lagoon 1 using a shallow-soil mixing method, such as a hollow stem mixing/drilling tool. This usually consists of fixed rotating large-diameter blades, with injection ports located along the base of the tool. As the tool is pushed into the ground, a slurry mixture is injected. Once the final depth is reached, the tool is raised and lowered in a predetermined mixing pattern to ensure a homogenous mix over the entire area. For this case, a 6 percent Portland cement mixture was selected as the grouting material.

Lagoon 1 Barrier Wall

A soil-bentonite barrier wall would be installed to divert groundwater around the portion of Lagoon 1 that is below the groundwater table. The wall would be keyed into the underlying till and would be installed such that water would be directed around the Lagoon 1 area.

A 0.6-meter-wide (2-foot-wide) by approximately 125-meter-long (408-foot-long) trench would be excavated around the perimeter of Lagoon 1. The trench would be approximately 5.2 meters (17 feet) deep and would extend 1 meter (3 feet) into the Lavery Till. A hydraulic excavator would be used to excavate the slurry trench for eventual installation of the soil-bentonite backfill material.

Once the wall is complete and begins to set up, the upper 1-meter (3-foot) section would be backfilled. Traffic areas would be backfilled with stone to allow heavy equipment to bridge the wall. The resulting barrier wall would have an in-place saturated hydraulic conductivity of approximately 1.0×10^{-8} centimeters (4.0×10^{-9} inches) per second. The Lagoon 1 barrier wall is discussed in detail in Section 4.10.

Lagoons 2 and 3

Lagoons 2 and 3 would be solidified with Portland cement using standard excavation equipment. The sediment solidification task would be accomplished using standard equipment (i.e., a hydraulic excavator). Once the sediment in the vicinity of the excavator is solidified, the working platform would be extended, and solidification would continue into a nearby area. Backfilling of the lagoon would be performed after sediment

solidification is complete. The transfer pump shed would be demolished and disposed of as construction and demolition debris.

Lagoons 4 and 5

Lagoons 4 and 5 are lined lagoons with little or no accumulated sediments. Demolition of the liners in these lagoons would involve using heavy equipment to destroy the integrity of the liners and mixing the liner fragments with solidified sediments, ensuring that there will be no future likelihood of perched water in the lagoon area.

C.3.2.2.3 Completion of Final Status Surveys in Waste Management Area 2

After completion of decommissioning activities within WMA 2, a final status survey of the area would be performed in accordance with a final status survey plan. RCRA confirmatory sampling would also be performed. Arrangements would also be made, as needed, for independent verification surveys.

The results of the final status survey, combined with information such as groundwater monitoring data, historical subsurface soil sample data, the results of the initial surface soil and sediment characterization surveys, and data from the final status surveys of those facilities closed in place, would describe the radiological and hazardous chemical conditions within WMA 2 at the completion of all decommissioning activities. This information would be used to confirm that decommissioning requirements have been met.

C.3.2.2.4 Estimated Waste to be Generated

The estimated waste volumes expected to be generated under the Sitewide Close-In-Place Alternative in WMA 2 are presented in **Table C-31**.

Table C-31 Estimated Waste to be Generated: Waste Management Area 2

<i>Waste Type</i>	<i>Waste Volume (cubic feet)</i>
Construction and Demolition Debris	550
Hazardous Waste	0
Low-level Radioactive Waste	
Low Specific Activity	33,000
Class A	720
Class B	0
Class C	0
Greater-Than-Class C Waste	0
Mixed Low-level Radioactive Waste	0
Transuranic Waste	0

Notes: The estimated waste volumes are based on commercial disposal and are presented with two significant figures. To convert cubic feet to cubic meters, multiply by 0.028317.

Source: WSMS 2009b.

C.3.2.3 Waste Management Area 3: Waste Tank Farm Area

The following closure activities would be implemented in WMA 3 under the Sitewide Close-In-Place Alternative.

- Tanks 8D-1, 8D-2, 8D-3, and 8D-4 and their associated vaults would be backfilled with controlled low strength material and strong grout. Controlled low strength material is a self-compacting, cementitious material used primarily as a backfill in lieu of compacted backfill. It is defined as a material that has a

compressive strength of 84 kilograms per square centimeter (1,200 pounds per square inch) or less, although most controlled low strength material applications require unconfined compressive strengths of 14 kilograms per square centimeter (200 pounds per square inch) or less. This lower strength requirement is necessary to allow for future excavation of the controlled low strength material. The sorbent capabilities of controlled low strength material would significantly retard the mobilization and migration of residual radionuclides in groundwater. The controlled low strength material would also serve to structurally stabilize the tanks by replacing the void space with a structurally stable material. The strong grout would serve as an intruder barrier.

- The STS equipment would remain and be closed within Tank 8D-1. The spent zeolite would remain in the columns and the isotope exchange unit columns. The supernatant feed tank and the sluice feed tank would be filled with grout.
- The underground lines within WMA 3 would remain in place, including lines running from the Tank 8D-2 pump pit to the STS Support Building; the dewatering well would also remain in place.
- The high-level radioactive waste mobilization and transfer pumps would be removed, sectioned, packaged, and disposed of off site as low-level radioactive waste or transuranic waste.
- The high-level radioactive waste pump support structures would be removed and incorporated into an engineered rubble pile beneath a multi-layer cap that would be constructed.
- The High-Level Waste Transfer Trench piping would be grouted and left in place within the transfer trench. The transfer trench would be filled with demolition debris and concrete rubble.
- The Equipment Shelter and Condensers; Con-Ed Building; Permanent Ventilation System Building; and STS Support Building, including the STS Valve Aisle; would be demolished down to their concrete floor slabs after all equipment has been removed. The slabs would remain in place. All demolition debris would be incorporated into the rubble pile.
- The Tank and Vault Drying System equipment installed as part of the starting point of the EIS (see Section C.2.3.1) would be removed.
- A vertical circumferential hydraulic barrier would be constructed around WMA 1 and WMA 3. The barrier would be a soil-bentonite wall extending to sufficient depth to position it at least 1 meter (3 feet) into the unweathered Lavery till. This barrier wall would be constructed to channel groundwater around the closed facilities and help minimize the possibility of an excessive hydraulic head developing within the closed facilities. A second chevron-shaped barrier wall would be located upgradient of the closed facilities to prevent mounding of groundwater against the circumferential barrier wall. The circumferential barrier wall is discussed in Section C.4.8.
- A multi-layer closure cap would be constructed over the closed facilities to minimize infiltration of precipitation into the stabilized facilities. The lateral limits of the closure cap would extend over both the upgradient and circumferential barrier walls. The selected closure cap slope is consistent with the maximum slope allowed for in-place closure of uranium mill tailing piles. This criterion was developed to provide an optimal balance between the objectives of promoting drainage, minimizing erosion, and assuring slope stability. The multi-layer closure cap is described in Section C.4.8.
- A final status survey would be performed in the area to be covered by the cap.

These activities would be accomplished in an appropriate sequence to maintain operations of the Tank and Vault Drying System as long as practicable. These activities are described in more detail in the sections that follow.

C.3.2.3.1 Stabilization of Tanks 8D-1, 8D-2, 8D-3, and 8D-4 and Associated Vaults

Tanks 8D-1, 8D-2, 8D-3, and 8D-4 and their associated vaults would be closed in place. The tanks would first be filled with controlled low strength material containing sorbents and reducing materials to retard radionuclide migration. The tank vaults would be filled with controlled low strength material to a level coincident with the top of the tanks. The headspace between the top of the tank and the vault roof and any tank and vault penetrations would be filled with strong grout that has a compressive strength in excess of 141 kilograms per square centimeter (2,000 pounds per square inch) to serve as an intruder barrier.

The controlled low strength material mixture would consist of Portland cement, fly ash, ground granulated blast furnace slag, phosphatic ore, and water, and would have a compressive strength ranging from approximately 4 to 14 kilograms per square centimeter (50 to 200 pounds per square inch). The blast furnace slag and phosphatic ore, which contains the mineral apatite, would improve the ability of the controlled low strength material to limit the mobilization and migration of long-lived radioactive isotopes.

C.3.2.3.2 Removal of Waste Tank Pumps and Pump Support Structures

Removal of the waste tank pumps is described in Section C.3.1.3.2. Each pump would be removed using appropriate radiological controls. The pumps would be cut into sections during removal and packaged for offsite disposal. It is assumed that the pumps would be classified as either transuranic waste or low-level radioactive waste.

The pump support structures would be removed in connection with removal of the pumps, and the resulting material would be incorporated into the engineered rubble pile beneath the WMA 3 cap.

C.3.2.3.3 High-Level Waste Transfer Trench Piping

The transfer trench itself is not expected to be radiologically contaminated because the piping did not leak and contamination has not been detected in water collected in the trench.

Using appropriate radiological controls, the piping would be filled with grout and left in place. The piping and other equipment in the pits would also be managed in this manner; this effort would be coordinated with removal of the waste tank pumps and grouting of the tanks and vaults. The transfer trench would subsequently be filled with demolition debris and concrete rubble.

C.3.2.3.4 Demolition of the Permanent Ventilation System Building

The Permanent Ventilation System Building would remain in operation until no longer needed for Waste Tank Farm closure work, such as filling the underground waste tanks with controlled low strength material.

The ventilation system equipment in the Permanent Ventilation System Building, which contains the majority of the radionuclide inventory in the structure, would be incorporated into the rubble pile beneath the WMA 3 cover after the tanks in the Waste Tank Farm have been stabilized. Once the ventilation system equipment is removed, the Permanent Ventilation System Building would be demolished by conventional methods without the need of confinement using a demolition machine equipped with a demolition hammer and shear. A spray fixative would be applied to the interior surfaces of the structure, including the Permanent Ventilation System stack, before demolition.

The Permanent Ventilation System stack would be removed and sectioned using the shear attachment of the demolition machine. The shear would be used to section, remove, and reduce the size of the metal walls and roof of the building. After the metal walls have been removed, the demolition machine, equipped with a demolition hammer, would be used to demolish and remove the concrete walls to the floor slab. The demolition debris would be incorporated into the WMA 3 engineered rubble pile.

C.3.2.3.5 Demolition of the Supernatant Treatment System Support Building

An approach similar to the following would be used to remove this building to the floor slab and foundation:

- Perform characterization surveys.
- Install suitable radiological containment with HEPA-filtered ventilation exhaust for removal of the Valve Aisle.
- Remove equipment and waste from the Valve Aisle.
- Decontaminate the interior of the Valve Aisle, as appropriate, to facilitate dismantlement, and apply a suitable fixative to interior surfaces.
- Cut the structure of the Valve Aisle into sections suitable for handling and disposal using equipment appropriate for cutting thick, contaminated steel plates, such as a diamond-wire saw operated inside a containment tent with HEPA-filtered ventilation exhaust.
- Complete removal of the Valve Aisle.
- Decontaminate the building structure, and apply fixatives to contaminated areas, as appropriate, prior to demolition.
- Perform characterization surveys of contaminated embedded piping that will remain in the floor slab so the results can be considered in the refined performance assessment, and cap this embedded piping.
- Dismantle the structure to the floor slab using conventional demolition methods without confinement.

All of the waste and demolition debris would be incorporated into the WMA 3 engineered rubble pile.

C.3.2.3.6 Demolition of the Equipment Shelter and Condensers

The demolition of the Equipment Shelter and Condensers would be performed the same way as under the Sitewide Removal Alternative, described in Section C.3.1.3.5. All of the waste and demolition debris would be incorporated into the WMA 3 engineered rubble pile.

C.3.2.3.7 Demolition of the Con-Ed Building

The demolition of the Con-Ed Building would be performed the same way as under the Sitewide Removal Alternative, discussed in Section C.3.1.3.6. All of the waste and demolition debris would be incorporated into the WMA 3 engineered rubble pile.

C.3.2.3.8 Installation of the Waste Management Area 1 and Waste Management Area 3 Circumferential Hydraulic Barrier Walls and Multi-layer Cap

A single subsurface circumferential barrier wall would be constructed around the partially demolished and stabilized facilities in WMA 1 and WMA 3. In addition to this circumferential barrier wall, a separate, chevron-shaped subsurface barrier wall would be constructed hydraulically upgradient of the circumferential barrier wall. This upgradient barrier wall would be oriented transverse to the direction of groundwater flow to divert groundwater flow and to help prevent groundwater mounding from occurring against the upgradient side of the circumferential barrier wall.

A multi-layer cover system would be constructed over these facilities and the subsurface barrier walls. The top-slope portion of the multi-layer cover system would extend laterally to just beyond the top of the barrier walls, and the side-slope portions of the cover system would be located outside the limits of the barrier walls.

The hydraulic barrier wall and the multi-layer cap are discussed in Section C.4.8.

C.3.2.3.9 Site Restoration

After completion of barrier wall and final cap installation, a final status survey of the area would be performed in accordance with a final status survey plan. RCRA confirmatory sampling would also be performed. Arrangements would also be made for independent verification surveys.

The results of the surveys, combined with information such as groundwater monitoring data, historical subsurface soil sample data, the results of the initial surface soil and sediment characterization surveys, and the estimated radioactivity inventories of the underground waste tanks and their associated vaults, would describe the radiological and hazardous chemical conditions within WMA 1 and WMA 3 at the time of the installation of the multi-layer cap. This information would be used to confirm that decommissioning requirements have been met.

C.3.2.3.10 Estimated Waste to be Generated

The estimated waste volumes expected to be generated under the Sitewide Close-In-Place Alternative in WMA 3 are presented in **Table C-32**. The estimate includes the removal of surface structures, grouting operations, and the construction of the barrier walls and multi-layer cap.

Table C-32 Estimated Waste to be Generated: Waste Management Area 3

<i>Waste Type</i>	<i>Waste Volume (cubic feet)</i>
Construction and Demolition Debris	0
Hazardous Waste	0
Low-level Radioactive Waste	
Low Specific Activity	56,000
Class A	4,300
Class B	110
Class C	1,300
Greater-Than-Class C Waste	0
Mixed Low-level Radioactive Waste	0
Transuranic Waste	1,200

Notes: The estimated waste volumes are based on commercial disposal and are presented with two significant figures. To convert cubic feet to cubic meters, multiply by 0.028317.

Source: WSMS 2009b.

These activities are described in more detail in the sections that follow.

C.3.2.4 Waste Management Area 4: Construction and Demolition Debris Landfill

The CDDL would continue to be monitored and maintained under the Sitewide Close-In-Place Alternative. However, characterization surveys of surface soil and sediment in the area would be performed. The results of these surveys would establish the baseline conditions for surface soil and sediment in WMA 4 as decommissioning work begins elsewhere on the Project Premises.

After completion of decommissioning activities in other WMAs, a final status survey of WMA 4 would be performed in accordance with a final status survey plan. RCRA confirmatory sampling would also be performed. Arrangements would also be made for independent verification surveys.

The results of the surveys, combined with other information such as groundwater monitoring data, historical subsurface soil sample data, and the results of the initial surface soil and sediment characterization surveys, would describe the radiological and hazardous chemical conditions within WMA 4 at the completion of all decommissioning activities.

C.3.2.5 Waste Management Area 5: Waste Storage Area

Under the Sitewide Close-In-Place Alternative, Lag Storage Area 4 and the associated Shipping Depot and Remote-Handled Waste Facility would be demolished to grade. The underground portion of the Remote-Handled Waste Facility would be filled with appropriate clean backfill material, and the remaining concrete floor slabs and foundations would remain in place.

C.3.2.5.1 Demolition of the Lag Storage Area 4 and Shipping Depot

The structures would be demolished without confinement to their floor slabs and foundations, with the demolition debris disposed of off site as construction and demolition debris. The disposal facilities assumed for final disposition of these types of wastes are local construction and demolition debris landfills or sanitary landfills.

C.3.2.5.2 Demolition of the Remote-Handled Waste Facility

Closure of this facility under a NYSDEC-approved RCRA closure plan would be coordinated with other demolition requirements. The Remote-Handled Waste Facility would be demolished to grade level by conventional methods without confinement.

Equipment would be disposed of as Class A low-level radioactive waste. The office building demolition debris would be disposed of as construction and demolition debris. The underground decontamination Waste Transfer Lines from the Batch Transfer Tank to Tank 8D-3 in WMA 3 would be grouted and remain in place. The majority of the debris generated from the facility demolition would be classified as low-specific-activity waste.

After completion of this work, a final status survey would be performed in the underground vault, and arrangements would be made for any necessary independent verification surveys. After completion of these surveys, the vault would be covered with appropriate clean backfill material.

C.3.2.5.3 Completion of Final Status Surveys in Waste Management Area 5

After completion of decommissioning activities within WMA 5, a final status survey of the area would be performed in accordance with a final status survey plan. RCRA confirmatory sampling would also be performed. Arrangements would also be made for independent verification surveys.

The results of the surveys, combined with information such as groundwater monitoring data, historical subsurface soil sample data, the results of the initial surface soil and sediment characterization surveys, and data from the final status survey of the Remote-Handled Waste Facility vault, would describe the radiological and hazardous chemical conditions within WMA 5 at the completion of all decommissioning activities. This information would be used to confirm that decommissioning requirements have been met.

C.3.2.5.4 Estimated Waste to be Generated

The estimated waste volumes expected to be generated under the Sitewide Close-In-Place Alternative in WMA 5 are presented in **Table C-33**.

Table C-33 Estimated Waste to be Generated: Waste Management Area 5

<i>Waste Type</i>	<i>Waste Volume (cubic feet)</i>
Construction and Demolition Debris	24,000
Hazardous Waste	0
Low-level Radioactive Waste	
Low Specific Activity	51,000
Class A	33,000
Class B	0
Class C	0
Greater-Than-Class C Waste	0
Mixed Low-level Radioactive Waste	0
Transuranic Waste	0

Notes: The estimated waste volumes are based on commercial disposal and are presented with two significant figures. To convert cubic feet to cubic meters, multiply by 0.028317.

Source: WSMS 2009b.

C.3.2.6 Waste Management Area 6: Central Project Premises

Under the Sitewide Close-In-Place Alternative, the Rail Spur and Low-Level Waste Rail Packaging and Staging Area would remain in place. The Demineralizer Sludge Ponds, Equalization Basin, and Equalization Tank would be covered with appropriate fill. The Sewage Treatment Plant and South Waste Tank Farm Test Tower would be demolished to ground level, and remaining subsurface facilities would be filled with appropriate clean backfill material.

C.3.2.6.1 Removal of Structures/Facilities

Demineralizer Sludge Ponds

A final status survey would be performed in both ponds. Arrangements would be made for independent verification surveys. After completion of the surveys, the ponds would be filled with appropriate clean backfill material.

Equalization Basin

To eliminate the future potential for perched water in the Equalization Basin, the liner would be removed and disposed of off site as construction and demolition debris, and the influent line would be filled with concrete. After completion of this work, a final status survey would be performed in the area, and arrangements would be made, as needed, for independent verification surveys. After completion of the surveys, the area would be filled with compacted soil.

Equalization Tank

The Equalization Tank would be partially demolished using conventional methods to prevent accumulation of water. A final status survey would be performed in the area, and arrangements would be made, as needed, for independent verification surveys. After completion of the surveys, the tank would be filled with appropriate clean backfill material.

Sewage Treatment Plant

The facility would be removed to its concrete slab using conventional demolition methods. It is assumed that the demolition debris would be disposed of off site as construction and demolition debris. The underground concrete tanks associated with the plant would remain in place. However, they would be partially demolished to prevent accumulation of water and filled with appropriate clean backfill material.

South Waste Tank Farm Test Tower

This test tower would be removed to its concrete foundation using conventional demolition methods, and the debris would be disposed of off site as construction and demolition debris.

C.3.2.6.2 Completion of Final Status Surveys

After completion of decommissioning activities within WMA 6, a final status survey of the area would be performed in accordance with a final status survey plan. RCRA confirmatory sampling would also be performed. Arrangements would also be made, as needed, for independent verification surveys.

The results of the surveys, combined with information such as groundwater monitoring data, historical subsurface soil sample data, the results of the initial surface soil and sediment characterization surveys, and data from the final status surveys of the Equalization Basin, Equalization Tank, and Demineralizer Sludge Ponds, would describe the radiological and hazardous chemical conditions within WMA 6 at the completion of all decommissioning activities. This information would be used to confirm decommissioning requirements have been met.

C.3.2.6.3 Estimated Waste to be Generated

The estimated waste volumes expected to be generated under the Sitewide Close-In-Place Alternative in WMA 6 are presented in **Table C–34**.

Table C–34 Estimated Waste to be Generated: Waste Management Area 6

<i>Waste Type</i>	<i>Waste Volume (cubic feet)</i>
Construction and Demolition Debris	7,300
Hazardous Waste	0
Low-level Radioactive Waste	
Low Specific Activity	1,200
Class A	100
Class B	0
Class C	0
Greater-Than-Class C Waste	0
Mixed Low-level Radioactive Waste	0
Transuranic Waste	0

Notes: The estimated waste volumes are based on commercial disposal and are presented with two significant figures. To convert cubic feet to cubic meters, multiply by 0.028317.

Source: WSMS 2009b.

C.3.2.7 Waste Management Area 7: NRC-Licensed Disposal Area and Associated Facilities

Under the Sitewide Close-In-Place Alternative, the existing NDA geomembrane cover would be replaced with a robust multi-layer cap similar in design to the WMA 1 and WMA 3 multi-layer cap. Leachate would be removed from some of the disposal holes and trenches, and grout would be injected to stabilize them. A new standalone Leachate Treatment Facility, discussed in Section C.4.5, would be constructed for this purpose. This facility would also be used to support decommissioning activities at the SDA. The Liquid Pretreatment System would be removed. The Interceptor Trench would be emptied of leachate and filled with material such as cement grout. The buried Leachate Transfer Line, existing outside of the WMA 2 excavations, would be abandoned in place. The former lagoon and upgradient NDA barrier wall would also remain in place.

C.3.2.7.1 Removal of Structures/Facilities

Liquid Pretreatment System

The equipment in the Liquid Pretreatment System would be reduced in size, as necessary, and transported off site for disposal as construction and demolition debris. The structures would be demolished by conventional means, and the rubble would be disposed of off site as construction and demolition debris.

Interceptor Trench

Water would be drained from the trench and the sump. The trench would then be grouted using either a dilute Portland cement-sand slurry or a silicate grout mixture that would be introduced into the trench backfill through a series of injection lances either driven vertically into, or excavated directly alongside, the trench. A surface-based pressure grouting apparatus would be used for injecting grout into the injection lances. The seven associated manholes and connecting drain pipes would also be filled with grout.

C.3.2.7.2 Leachate Removal and Grouting of Holes, Trenches, and Caissons

Prior to constructing the multi-layer cover system, selected disposal holes and trenches within the NDA would be grouted to mitigate the potential effects of future long-term subsidence. An area-based criterion would be used for selecting disposal holes and trenches to be grouted. Leachate would be removed, as necessary, from these areas as they are grouted.

Portions of the geomembrane cover would be removed, as necessary, to support leachate removal and grouting work. These portions would be reinstalled after the work is completed so the geomembrane would remain essentially intact until installation of the multi-layer cap begins.

Disposal holes and trenches that have any surface dimension greater than 6.1 meters (20 feet) in length would be grouted based on the area-based criterion. For conceptual design purposes, it has been assumed that the disposal trenches and holes selected for grouting would be grouted from approximately 1.2 meters (4 feet) below the ground surface to their bottoms.

Removal and Treatment of Leachate

Before initiating grouting, leachate may need to be extracted from disposal holes or trenches that contain significant amounts of leachate. The leachate would be treated in the Leachate Treatment Facility, and the treated effluent would be released through an SPDES-permitted outfall. Leachate management would continue in parallel with trench grouting.

Installation of Grout

Grout injection pipes would be driven into the NDA disposal holes and trenches selected for grouting; the intent of this action would be to inject grout to fill void spaces present within the disposal holes and trenches. The pipes would be installed in an appropriate pattern at a grid spacing designed to be sufficient to promote a very high percentage of void space infilling. An estimated 6,700 cubic meters (235,000 cubic feet) of grout would be injected to fill the void spaces within these holes and trenches. It is also assumed that an equal quantity of leachate would be displaced.

Caissons

The caissons would be covered by the multi-layer caps. Based on their small surface dimensions, grout is not assumed to be necessary.

C.3.2.7.3 Installation of Engineered Multi-layer Cover System

The design and installation of the NDA multi-layer cap would be similar to the WMA 1 and WMA 3 multi-layer cap. It is discussed in Section C.4.11.

C.3.2.7.4 Erosion Control Features

Installation of the erosion control features discussed in Section C.4.13 would be coordinated with construction of the NDA (and SDA) caps so the features that support surface water drainage in the cap area would be in place when cap installation is completed.

C.3.2.7.5 Final Conditions

After the NDA closure system is in place and as other decommissioning work associated with this alternative is being completed, the NDA area would be monitored and maintained. A perimeter of large boulders would be installed around the NDA to eliminate the potential for future vehicular access to the cap. The environmental monitoring program would include monitoring the effectiveness of the cover system and barrier wall in limiting infiltration of precipitation and groundwater into the burial area.

C.3.2.7.6 Estimated Waste to be Generated

The estimated waste volumes expected to be generated under the Sitewide Close-In-Place Alternative in WMA 7 are presented in **Table C–35**. The estimates include the construction and operation of all structures, other than the Leachate Treatment Facility, supporting the exhumation activities in WMA 7. The estimated waste volumes expected to be generated during the construction, operation, and closure of the Leachate Treatment Facility, which would be built to support the waste processing activities in the NDA and SDA, are presented in **Table C–36**. Sitewide erosion controls are not included in these tables.

Table C-35 Estimated Waste to be Generated: Waste Management Area 7

<i>Waste Type</i>	<i>Waste Volume (cubic feet)^a</i>
Construction and Demolition Debris	15,000
Hazardous Waste	0
Low-level Radioactive Waste	
Low Specific Activity	0
Class A	0
Class B	0
Class C	0
Greater-Than-Class C Waste	0
Mixed Low-level Radioactive Waste	0
Transuranic Waste	0

^a The waste volumes do not include those associated with the Leachate Treatment Facility.

Note: The estimated waste volumes are based on commercial disposal and are presented with two significant figures. To convert cubic feet to cubic meters, multiply by 0.028317.

Source: WSMS 2009b.

Table C-36 Estimated Waste to be Generated: Leachate Treatment Facility

<i>Waste Type</i>	<i>Waste Volume (cubic feet)</i>
Construction and Demolition Debris	2,200
Hazardous Waste	0
Low-level Radioactive Waste	
Low Specific Activity	12,000
Class A	35,000
Class B	0
Class C	980
Greater-Than-Class C Waste	0
Mixed Low-level Radioactive Waste	13,000
Transuranic Waste	0

Note: The estimated waste volumes are based on commercial disposal and are presented with two significant figures. To convert cubic feet to cubic meters, multiply by 0.028317.

Source: WSMS 2009b.

C.3.2.8 Waste Management Area 8: State-Licensed Disposal Area and Associated Facilities

The following activities would take place under the Sitewide Close-In-Place Alternative:

- The three tanks and associated equipment in the Mixed Waste Storage Facility would be removed, and the facility would be demolished to grade.
- The Leachate Treatment Facility, described in Section C.4.5, would be used to pump out and treat leachate from the SDA trenches.
- The SDA burial trenches would be grouted to mitigate potential subsidence.
- An engineered multi-layer cap similar to those used for the NDA and WMAs 1 and 3 would be installed over the SDA.
- The SDA lagoons would be left in place.

The SDA would be closed in accordance with a closure plan approved by the NYSDEC Hazardous Waste and Radiation Programs.

C.3.2.8.1 Removal of Structures/Facilities

Mixed Waste Storage Facility

Characterization surveys would be performed in the facility. Any remaining leachate in the tanks would be removed and processed in the Leachate Treatment Facility. The tanks and other equipment would be removed and reduced in size, as necessary. Tank T-1 could be disposed of as either Class A low-level radioactive waste or mixed low-level radioactive waste.² It is assumed that Tanks T-2 and T-3 would be disposed of as construction and demolition debris because they were never used. However, these tanks may be sold or recycled. The structures would be demolished by conventional means.

C.3.2.8.2 Leachate Removal and Trench Grouting

Prior to constructing the multi-layer cover system, burial trenches within the SDA would be grouted to mitigate the potential effects of long-term subsidence within these trenches on the cover system. Portions of the geomembrane cover would be removed, as necessary, to facilitate this work.

Leachate would be pumped from the SDA trenches and treated at the Leachate Treatment Facility before and during the trench grouting activities. It is assumed that approximately 40,000 cubic meters (1.4 million cubic feet) of grout would be used to properly stabilize the SDA trenches and that an equal volume of leachate would be processed.

C.3.2.8.3 Installation of Engineered Multi-layer Cover System

The design and installation of the SDA multi-layer cap would be similar to the NDA cap. It is discussed in Section C.4.11.

C.3.2.8.4 Erosion Control Features

Installation of the erosion control features described in Section C.4.13 would be coordinated with construction of the SDA cap (and NDA cap) so the features that support surface water drainage in the cap area would be in place when cap installation is completed.

C.3.2.8.5 Final Conditions

After the SDA closure system is in place, and as other decommissioning work associated with this alternative is being completed, the SDA area would be monitored and maintained. A perimeter of large boulders would be installed around the SDA to deter vehicular access to the capped area. The environmental monitoring program would include monitoring the effectiveness of the cover system, the barrier wall, and the French drain in limiting infiltration of precipitation and groundwater into the burial area.

C.3.2.8.6 Estimated Waste to be Generated

The estimated waste volumes expected to be generated under the Sitewide Close-In-Place Alternative in WMA 8 are presented in **Table C-37**. The estimated waste to be generated from the construction, operation, and demolition of the Leachate Treatment Facility is given in **Table C-36**.

² Tank T-1 may be removed prior to the starting point of this EIS. For purposes of analysis in this EIS, Tank T-1 is included in the inventory of low-level radioactive waste.

Table C-37 Estimated Waste to be Generated: Waste Management Area 8

<i>Waste Type</i>	<i>Waste Volume (cubic feet)</i>
Construction and Demolition Debris	70,000
Hazardous Waste	0
Low-level Radioactive Waste	
Low Specific Activity	10,000
Class A	1,400
Class B	0
Class C	0
Greater-Than-Class C Waste	0
Mixed Low-level Radioactive Waste	0
Transuranic Waste	0

Note: The estimated waste volumes are based on commercial disposal and are presented with two significant figures. To convert cubic feet to cubic meters, multiply by 0.028317.

Source: WSMS 2009b.

C.3.2.9 Waste Management Area 9: Radwaste Treatment System Drum Cell

Under the Sitewide Close-In-Place Alternative, the Drum Cell would be removed, along with its associated monitoring shed. There are no planned activities for the Subcontractor Maintenance Area. The NDA Trench Soil Container Area (pad) would also be left in place.

C.3.2.9.1 Removal of the Radwaste Treatment System Drum Cell

Before decommissioning activities begin in WMA 9, characterization surveys of surface soil and sediment in the area and inside the Drum Cell would be performed. The Drum Cell would be demolished using conventional means to its gravel pad and foundation. It is assumed that the demolition debris would be disposed of off site as construction and demolition debris. The disposal facilities assumed for final disposition of these types of waste are local construction and demolition debris landfills or sanitary landfills.

After completion of this work, final status surveys of the area would be performed. RCRA confirmatory sampling would also be performed. Arrangements would also be made for independent verification surveys. The results of the surveys, combined with information such as groundwater monitoring data, historical subsurface soil sample data, and the results of the initial surface soil and sediment characterization surveys, would describe the radiological and hazardous chemical conditions within WMA 9 at the completion of all decommissioning activities. This information would be used to confirm that decommissioning requirements have been met.

C.3.2.9.2 Estimated Waste to be Generated

The estimated waste volumes expected to be generated under the Sitewide Close-In-Place Alternative in WMA 9 are presented in **Table C-38**.

Table C–38 Estimated Waste to be Generated: Waste Management Area 9

<i>Waste Type</i>	<i>Waste Volume (cubic feet)</i>
Construction and Demolition Debris	89,000
Hazardous Waste	0
Low-level Radioactive Waste	
Low Specific Activity	0
Class A	0
Class B	0
Class C	0
Greater-Than-Class C Waste	0
Mixed Low-level Radioactive Waste	0
Transuranic Waste	0

Notes: The estimated waste volumes are based on commercial disposal and are presented with two significant figures. To convert cubic feet to cubic meters, multiply by 0.028317.

Source: WSMS 2009b.

C.3.2.10 Waste Management Area 10: Support and Services Area

Under the Sitewide Close-In-Place Alternative, the New Warehouse would be demolished to grade. The Meteorological Tower and the Security Gatehouse and fences would remain in place. The remaining floor slabs and foundations would also remain in place.

C.3.2.10.1 Removal of Structures/Facilities

New Warehouse

The New Warehouse would be demolished using conventional means to its concrete slab, and the demolition debris would be disposed of off site as construction and demolition debris.

After completion of this work, final status surveys of the area would be performed. RCRA confirmatory sampling would also be performed. Arrangements would also be made for independent verification surveys. The results of the surveys, combined with information such as groundwater monitoring data, historical subsurface soil sample data, and the results of the initial surface soil and sediment characterization surveys, would completely describe the radiological and hazardous chemical conditions within WMA 10 at the completion of all decommissioning activities. This information would be used to confirm that decommissioning requirements have been met.

C.3.2.10.2 Estimated Waste to be Generated

The estimated waste volumes expected to be generated under the Sitewide Close-In-Place Alternative in WMA 10 are presented in **Table C–39**.

Table C–39 Estimated Waste to be Generated: Waste Management Area 10

<i>Waste Type</i>	<i>Waste Volume (cubic feet)</i>
Construction and Demolition Debris	23,000
Hazardous Waste	0
Low-level Radioactive Waste	
Low Specific Activity	0
Class A	0
Class B	0
Class C	0
Greater-Than-Class C Waste	0
Mixed Low-level Radioactive Waste	0
Transuranic Waste	0

Notes: The estimated waste volumes are based on commercial disposal and are presented with two significant figures. To convert cubic feet to cubic meters, multiply by 0.028317.

Source: WSMS 2009b.

C.3.2.11 Waste Management Area 11: Bulk Storage Warehouse and Hydrofracture Test Well Area

No decommissioning activities would take place in WMA 11 under the Sitewide Close-In-Place Alternative. As a result, no waste would be generated. The results of the final status survey, and RCRA confirmatory sampling, combined with information such as groundwater monitoring data, historical subsurface soil sample data, and the results of the initial surface soil and sediment characterization surveys would describe the radiological and hazardous chemical conditions within WMA 11 at the completion of all decommissioning activities. This information would be used to confirm that decommissioning requirements have been met.

C.3.2.12 Waste Management Area 12: Balance of Site

Under the Sitewide Close-In-Place Alternative, the dams and reservoirs would be taken out of service in accordance with applicable Federal and state regulations. The streambeds of Erdman Brook, Franks Creek, and Buttermilk Creek downstream of its confluence with Franks Creek, which have been impacted by releases of treated radioactive effluent or unintentional releases, would be subject to characterization surveys. These surveys would focus primarily on the known impacted areas. Parking lots and roadways would remain in place. The removal of the dams and reservoirs would proceed in the same manner as under the Sitewide Removal Alternative, discussed in Section C.3.1.12.1, except that only the middle third of the dams would be removed. Removal of a steel bridge spanning a reservoir and the reservoirs would not occur until after the high-level waste canisters have been removed from the site.

Much of the data collected during characterization surveys would be intended to serve final status survey purposes as well, because remediation of any areas exceeding DCGLs would not be undertaken for this alternative. Given this situation, arrangements would be made for any necessary independent verification surveys to be performed in conjunction with or following the characterization surveys.

At the conclusion of all site decommissioning activities, final status surveys of WMA 12 would be performed. These surveys would focus on areas that may have been impacted during decommissioning activities, taking into account the scope and results of the characterization surveys. RCRA confirmatory sampling would also be performed. Arrangements would also be made, as needed, for independent verification surveys. The results of these surveys, combined with information such as the results of the initial surface soil and sediment characterization surveys and the results of the site environmental monitoring program, would be used to confirm that decommissioning requirements have been met.

Estimated Waste to be Generated

The estimated waste volumes expected to be generated under the Sitewide Close-In-Place Alternative in WMA 12 are presented in **Table C–40**. The estimate includes miscellaneous sitewide generation of waste from activities including maintenance of existing facilities, security, environmental monitoring installations, security installations, erosion control installations, and long-term monitoring and maintenance. Although portions of these wastes could be generated in other areas of the site, they are included in the WMA 12 totals.

Table C–40 Estimated Waste to be Generated: Waste Management Area 12

<i>Waste Type</i>	<i>Waste Volume (cubic feet)</i>
Construction and Demolition Debris	99,000
Hazardous Waste	36
Low-level Radioactive Waste	
Low Specific Activity	4,800
Class A	26,000
Class B	0
Class C	0
Greater-Than-Class C Waste	0
Mixed Low-level Radioactive Waste	0
Transuranic Waste	0

Note: The estimated waste volumes are based on commercial disposal and are presented with two significant figures. To convert cubic feet to cubic meters, multiply by 0.028317.
Source: WSMS 2009b.

C.3.2.13 North Plateau Groundwater Plume

As discussed in Section C.2.13, a pump and treat system (Groundwater Recovery System), a pilot-scale permeable treatment wall, and a full-scale permeable treatment wall would have been installed at the starting point of this EIS for groundwater mitigation and remediation of the North Plateau Groundwater Plume.

Under the Sitewide Close-In-Place Alternative, the Groundwater Recovery System would be decommissioned. The permeable treatment wall would be periodically replaced approximately every 20 years.

The circumferential hydraulic barrier wall that would be installed around WMAs 1 and 3 under this alternative would provide containment of the upgradient portions of the North Plateau Groundwater Plume, where the source of the plume would remain in place. The plume would be allowed to decay in place.

The estimated waste volumes to be generated under the Sitewide Close-In-Place Alternative from the maintenance of the nonsource area of the North Plateau Groundwater Plume are presented in **Table C–41**. The waste volumes are entirely due to the periodic replacement of the permeable treatment wall.

C.3.2.14 Cesium Prong

The Cesium Prong would be managed by implementing restrictions on use for a nominal period of 100 years until in-place decay results in levels allowing for unrestricted use. As a result, no waste would be generated.

**Table C-41 Estimated Waste to be Generated: North Plateau Groundwater Plume
 (nonsource area)**

<i>Waste Type</i>	<i>Waste Volume (cubic feet)</i>
Construction and Demolition Debris	0
Hazardous Waste	0
Low-level Radioactive Waste	
Low Specific Activity	217,000
Class A	1,000
Class B	0
Class C	0
Greater-Than-Class C Waste	0
Mixed Low-level Radioactive Waste	0
Transuranic Waste	0

Notes: The estimated waste volumes are based on commercial disposal and are presented with two significant figures. To convert cubic feet to cubic meters, multiply by 0.028317.

Source: WSMS 2009b.

C.3.3 Phased Decisionmaking Alternative

Under the Phased Decisionmaking Alternative, decommissioning would be carried out in two phases:

Phase 1

- Phase 1 would include removal of all WMA 1, 2, 5, and 9 facilities, the WMA 2 lagoons, the source area of the North Plateau Groundwater Plume, and all facilities other than the Rail Spur in WMA 6. No WMA 4, 8, or 11 facilities or areas would be removed.

In WMA 3, mobilization and transfer pumps associated with Tanks 8D-1 through 8D-4 and the piping associated with the High-Level Waste Transfer Trench would be removed, as would the Waste Tank Farm Equipment Shelter and Condensers, the Permanent Ventilation System Building, and the Con-Ed Building. The NDA HardStand Staging Area would be removed in WMA 7, and the New Warehouse would be removed in WMA 10. The permeable treatment wall in the North Plateau Groundwater Plume area would be periodically replaced.

Various floor slabs, gravel pads, and foundations in WMAs 1, 2, 5, 6, 9, and 10 would be removed during Phase 1. Parts or all of WMAs 3, 4, 6, 7, 8, 10, and 12; the North Plateau Groundwater Plume area; and the Cesium Prong would be monitored and maintained. Section C.3.3.5.3 contains more detailed information about these activities.

Activities would also include additional characterization of site contamination and studies to provide information to support additional evaluations to determine the technical approach to be used to complete the decommissioning.

Phase 2

- Phase 2 would complete decommissioning, following the approach determined through evaluations from the site characterization and studies to be conducted during and subsequent to Phase 1.

During Phase 1, the site would undergo an operations, monitoring, and maintenance program that is similar in concept but lesser in magnitude to what is currently in place at the site. Because the Main Plant Process

Building and lagoons would have been removed, these facilities would no longer require operations support, and monitoring and maintenance requirements would be significantly reduced. However, the environmental monitoring program, modified as needed to better fit the remaining WMAs, would continue at a magnitude similar to the current program. Environmental monitoring, modified as necessary, would ensure that unforeseen adverse impacts resulting from Phase 1 remedial activities or recontamination of Phase 1 sources are evaluated. Additionally, inspections and subsequent maintenance activities that are undertaken currently (e.g., erosion inspections, monitoring and maintenance, stormwater monitoring, cap maintenance) to safely operate the site would be continued until final disposition of the remaining WMAs is selected and implemented.

The following sections discuss in more detail the decommissioning activities that would take place during Phase 1 of the Phased Decisionmaking Alternative for each WMA.

Unless otherwise noted, information presented in Section C.3.3 is from the *Phased Decisionmaking Alternative Technical Report* (WSMS 2009c).

C.3.3.1 Waste Management Area 1: Main Plant Process Building and Vitrification Facility Area

During Phase 1 of the Phased Decisionmaking Alternative, the high-level radioactive waste canisters stored in the Main Plant Process Building would be relocated. All facilities, including underground structures and remaining floor slabs and foundations of WMA 1, would be removed. These facilities include the Main Plant Process Building; Vitrification Facility; 01-14 Building; Load-In/Load-Out Facility; Utility Room and Utility Room Expansion; Plant Office Building; Fire Pumphouse; Water Storage Tank; Electrical Substation; Off-Gas Trench; underground tanks (7D-13, 15D-6, 35104); and underground process, wastewater, and utility lines. The source area of the North Plateau Groundwater Plume would also be removed.

C.3.3.1.1 Relocation of the High-Level Radioactive Waste Canisters

Activities associated with relocation of the high-level radioactive waste canisters during Phase 1 of the Phased Decisionmaking Alternative are the same as those that would occur under the Sitewide Removal Alternative. They are discussed in Section C.3.1.1.1.

C.3.3.1.2 Demolition of the Main Plant Process Building

The process for demolition of the Main Plant Process Building under this alternative would be the same as the process under the Sitewide Removal Alternative, discussed in Section C.3.1.1.2.

C.3.3.1.3 Demolition of Other Waste Management Area 1 Structures

The process for demolition of all the remaining structures under this alternative would be the same as the process under the Sitewide Removal Alternative, discussed in Sections C.3.1.1.2 through C.3.1.1.6.

C.3.3.1.4 Excavation and Hydraulic Barrier Wall Installation

To facilitate removal of the underground structures of the Main Plant Process Building and Vitrification Facility, along with the source area of the North Plateau Groundwater Plume, an area larger than the footprint of both buildings would be excavated, as under the Sitewide Removal Alternative. The discussion of the excavation and the hydraulic barrier wall installation is included in Section C.3.1.1.7 and in the following sections.

C.3.3.1.5 Removal of the Plume Source Area, Underground Structures, and Equipment

The process for the removal of the North Plateau Groundwater Plume source area and the underground structures and equipment under this alternative would be the same as that for the Sitewide Removal Alternative, discussed in Section C.3.1.1.8, with some minor exceptions. In the same manner as the Sitewide Removal Alternative, soil would be excavated to a depth of at least 0.3 meters (1 foot) into the Lavery till; the extent of additional soil removal would be determined by the use of cleanup goals specified in the *Phase I Decommissioning Plan for the West Valley Demonstration Project (Decommissioning Plan)*. Remedial action surveys would be performed during the course of the work, and soil on the bottom of the excavation with radioactivity concentrations exceeding the cleanup goals would be removed and disposed of off site as radioactive waste. Soil would be excavated up to the barrier wall. The other sides of the WMA 1 excavation would have a side slope of approximately 45 degrees.

The horizontal limits of the excavation would be based primarily on physical considerations, although consideration would also be given to analytical data on subsurface soil contamination at the planned excavation boundary acquired early during Phase 1.

C.3.3.1.6 Site Restoration

The process for the site restoration of WMA 1 would be the same as that discussed for the Sitewide Removal Alternative in Section C.3.1.1.9.

C.3.3.1.7 Disposition of Support Facility Materials

The disposition of support facility material would be the same as that for the Sitewide Removal Alternative, discussed in Section C.3.1.1.10.

C.3.3.1.8 Estimated Waste to be Generated

The estimated waste volumes expected to be generated under the Phased Decisionmaking Alternative in WMA 1 are presented in **Table C-42**. The estimate includes the modification of the Load-In/Load-Out Facility and the operation and demolition of the Interim Storage Facility (Dry Cask Storage Area) associated with the high-level waste canister removal.

Table C-42 Estimated Waste to be Generated: Waste Management Area 1

<i>Waste Type</i>	<i>Waste Volume (cubic feet)</i>
Construction and Demolition Debris	440,000
Hazardous Waste	83
Low-level Radioactive Waste	
Low Specific Activity	3,500,000
Class A	280,000
Class B	3,100
Class C	9,000
Greater-Than-Class C Waste	0
Mixed Low-level Radioactive Waste	1,400
Transuranic Waste	24,000

Notes: The estimated waste volumes are based on commercial disposal and are presented with two significant figures. To convert cubic feet to cubic meters, multiply by 0.028317.

Source: WSMS 2009c.

C.3.3.2 Waste Management Area 2: Low-Level Waste Treatment Facility Area

The Phased Decisionmaking Alternative approach to closing WMA 2 is removal of all remaining surface structures and concrete floor slabs, exhumation of the contaminated waste and sediment contained in Lagoon 1, excavation of all contaminated sediment from Lagoons 2 and 3, removal of liners from Lagoons 4 and 5 and underlying contaminated soil, and restoration of the surface to a natural contour. The permeable treatment wall installed for the starting point of the EIS would be periodically replaced.

The difference between the Phased Decisionmaking Alternative and the Sitewide Removal Alternative for WMA 2 is the construction of a subsurface soil-cement-bentonite barrier wall. This barrier wall would be installed under the Phased Decisionmaking Alternative to prevent migration of the North Plateau Groundwater Plume back into the remediated source area and Main Plant Process Building excavation. Other than this difference, the decommissioning activities in WMA 2 for Phase 1 of the Phased Decisionmaking Alternative are the same as those discussed in Section C.3.1.2 for the Sitewide Removal Alternative. The barrier wall would be installed as discussed previously in Section C.3.1.1.7.

Estimated Waste to be Generated

The estimated waste volumes expected to be generated during Phase 1 of the Phased Decisionmaking Alternative in WMA 2 are presented in **Table C–43**.

Table C–43 Estimated Waste to be Generated: Waste Management Area 2

<i>Waste Type</i>	<i>Waste Volume (cubic feet)</i>
Construction and Demolition Debris	50,000
Hazardous Waste	0
Low-level Radioactive Waste	
Low Specific Activity	1,500,000
Class A	340,000
Class B	0
Class C	33,000
Greater-Than-Class C Waste	0
Mixed Low-level Radioactive Waste	0
Transuranic Waste	0

Notes: The estimated waste volumes are based on commercial disposal and are presented with two significant figures. To convert cubic feet to cubic meters, multiply by 0.028317.

Source: WSMS 2009c.

C.3.3.3 Waste Management Area 3: Waste Tank Farm Area

During Phase 1 of the Phased Decisionmaking Alternative, Tanks 8D-1, 8D-2, 8D-3, and 8D-4 would remain in place, as would the Permanent Ventilation System Building, STS Support Building, and underground piping in the area. The tanks would continue to be monitored and maintained with the Tank and Vault Drying System, as necessary. However, the high-level waste mobilization and transfer pumps would be removed from the tanks. The Equipment Shelter and Condensers, the Con-Ed Building, and piping in the High-Level Waste Transfer Trench would be removed.

C.3.3.3.1 Removal of Waste Tank Pumps and Pump Support Structures

The process of removing the waste tank pumps and the pump support structures would be the same as that for the Sitewide Removal Alternative; however, the Phased Decisionmaking Alternative does not include construction of the Waste Tank Farm Waste Processing Facility. Instead, temporary shelters and confinements would be erected to support this work. Descriptions of the pumps, support structures, and removal process are included in Section C.3.1.3.2.

C.3.3.3.2 Removal of High-Level Waste Transfer Trench Piping

The process of removing the High-Level Waste Transfer Trench piping would be the same as that for the Sitewide Removal Alternative, described in Section C.3.1.3.3.

C.3.3.3.3 Removal of the Permanent Ventilation System Building

The process for removing the Permanent Ventilation System Building would be the same as that for the Sitewide Removal Alternative, described in Section C.3.1.3.4.

C.3.3.3.4 Demolition of Equipment Shelter and Condensers

The demolition of the Equipment Shelter and Condensers would be performed the same way as under the Sitewide Removal Alternative, discussed in Section C.3.1.3.5.

C.3.3.3.5 Demolition of the Con-Ed Building

The demolition of the Con-Ed Building would be performed the same way as under the Sitewide Removal Alternative, discussed in Section C.3.1.3.6.

C.3.3.3.6 Monitoring and Maintenance

Monitoring and maintenance of the Waste Tank Farm would continue during Phase 1 of the Phased Decisionmaking Alternative. The Tank and Vault Drying System installed in achieving the starting point of the EIS would remain in operation. Decommissioning of the Waste Tank Farm would be conducted during Phase 2.

A dewatering well was installed during the construction of the waste tanks and has been used on a nearly continual basis to maintain the static water levels in the Waste Tank Farm Area in a depressed condition. The location of the dewatering well is approximately between Tanks 8D-1 and 8D-2, adjacent to the Permanent Ventilation System Building.

The dewatering well would continue to be used to lower the water table to minimize leakage of groundwater into the tank vaults. After the Low-Level Waste Treatment Facility is taken out of operation, it is assumed that the water would be collected, sampled, and released to Erdman Brook through a new SPDES-permitted outfall. Once the Low-Level Waste Treatment Facility is taken out of service and remediation is undertaken in this area, a groundwater holding tank would be required to complement the dewatering well process. It is estimated that a 76,000-liter (20,000-gallon) tank would be required for this purpose.

C.3.3.3.7 Estimated Waste to be Generated

The estimated waste volumes expected to be generated during Phase 1 of the Phased Decisionmaking Alternative in WMA 3 are presented in **Table C-44**.

Table C–44 Estimated Waste to be Generated: Waste Management Area 3

<i>Waste Type</i>	<i>Waste Volume (cubic feet)</i>
Construction and Demolition Debris	88,000
Hazardous Waste	0
Low-level Radioactive Waste	
Low Specific Activity	3,500
Class A	5,300
Class B	720
Class C	1,300
Greater-Than-Class C Waste	0
Mixed Low-level Radioactive Waste	0
Transuranic Waste	1,200

Notes: The estimated waste volumes are based on commercial disposal and are presented with two significant figures. To convert cubic feet to cubic meters, multiply by 0.028317.
Source: WSMS 2009c.

C.3.3.4 Waste Management Area 4: Construction and Demolition Debris Landfill

The CDDL would continue to be monitored and maintained during Phase 1 of the Phased Decisionmaking Alternative. No waste would be generated.

C.3.3.5 Waste Management Area 5: Waste Storage Area

During Phase 1 of the Phased Decisionmaking Alternative, Lag Storage Area 4 and the associated Shipping Depot and Remote-Handled Waste Facility would be removed. The remaining concrete floor slabs and foundations would also be removed. The work to be performed in WMA 5 under this alternative is the same as that under the Sitewide Removal Alternative, described in Section C.3.1.5.

C.3.3.5.1 Demolition of Lag Storage Area 4

The structures would be demolished without confinement and the floor slabs and foundations would be removed; resulting demolition debris would be disposed of off site as construction and demolition debris. Detailed discussion of this work is included in Section C.3.1.5.1.

Following removal of the structure and floor slab, up to 0.6 meters (2 feet) of soil would also be removed. Following this excavation, radiological surveys and RCRA confirmatory sampling would be performed to document conditions, and then backfilling would occur.

C.3.3.5.2 Demolition of the Remote-Handled Waste Facility

Closure of this facility under an NYSDEC-approved RCRA closure plan would be coordinated with its demolition under the *Decommissioning Plan*. The Remote-Handled Waste Facility would be demolished by conventional methods without confinement after it has completed processing of all equipment and waste requiring remote handling and characterization. Demolition of the structure would include removal of the underground tank vault; the rest of the building would be taken down entirely.

The demolition debris would be handled as low-specific-activity waste except the office building debris would be handled as construction and demolition debris and disposed of off site. The underground decontamination Waste Transfer Lines from the Batch Transfer Tank to Tank 8D-3 in WMA 3 would be cut off, characterized, and disposed of as Class A low-level radioactive waste.

Following removal of the structure and floor slab, up to 0.6 meters (2 feet) of soil would also be removed. Following this excavation, radiological surveys and RCRA confirmatory sampling would be performed collected to document conditions, and then backfilling would occur.

C.3.3.5.3 Removal of Remaining Floor Slabs, Foundations, and Gravel Pads

All remaining concrete floor slabs and foundations would be removed, including those associated with the Lag Storage Building, Lag Storage Area 1, and Lag Storage Area 3. The Lag Storage Area 2 Hardstand would also be removed, along with the gravel pads associated with the Chemical Process Cell Waste Storage Area, Hazardous Waste Storage Lockers, Cold Hardstand Area, Vitrification Vault and Empty Container Hardstand, Old/New Hardstand Area, and Lag Hardstand.

The floor slabs, foundations, hardstands, and gravel pads would be demolished by conventional means. The demolition debris would be disposed of as uncontaminated construction and demolition debris.

Following removal of the structure and floor slab, up to 0.6 meters (2 feet) of soil would also be removed. Following this excavation, radiological surveys and RCRA confirmatory sampling would be performed to document conditions, and then backfilling would occur.

C.3.3.5.4 Estimated Waste to be Generated

The estimated waste volumes expected to be generated during Phase 1 of the Phased Decisionmaking Alternative in WMA 5 are presented in **Table C-45**.

Table C-45 Estimated Waste to be Generated: Waste Management Area 5

<i>Waste Type</i>	<i>Waste Volume (cubic feet)</i>
Construction and Demolition Debris	190,000
Hazardous Waste	0
Low-level Radioactive Waste	
Low Specific Activity	100,000
Class A	32,000
Class B	0
Class C	0
Greater-Than-Class C Waste	0
Mixed Low-level Radioactive Waste	0
Transuranic Waste	0

Notes: The estimated waste volumes are based on commercial disposal and are presented with two significant figures. To convert cubic feet to cubic meters, multiply by 0.028317.
Source: WSMS 2009c.

C.3.3.6 Waste Management Area 6: Central Project Premises

During Phase 1 of the Phased Decisionmaking Alternative, the Rail Spur would remain in place. The Demineralizer Sludge Ponds, Equalization Basin, Equalization Tank, Sewage Treatment Plant, South Waste Tank Farm Test Tower, and Low-Level Waste Rail Packaging and Staging Area would be removed, along with the remaining pads and concrete floor slabs and foundations.

C.3.3.6.1 Removal of Structures/Facilities

During Phase 1 of the Phased Decisionmaking Alternative, the removal of structures, other than the Rail Spur, would be the same as that for the Sitewide Removal Alternative. The process of removing the structures in WMA 6 is described in Section C.3.1.6.1.

C.3.3.6.2 Removal of Remaining Floor Slabs and Foundations

The remaining floor slabs and foundations in the area, including underground structures of the Cooling Tower, would be removed along with up to 0.6 meters (2 feet) of underlying soil. Radiological and RCRA confirmatory sampling surveys would then be performed to document the conditions of the base of the excavation. After completion of the surveys, the excavated areas would be filled with appropriate clean backfill material.

C.3.3.6.3 Estimated Waste to be Generated

The estimated waste volumes expected to be generated during Phase 1 of the Phased Decisionmaking Alternative in WMA 6 are presented in **Table C-46**.

Table C-46 Estimated Waste to be Generated: Waste Management Area 6

<i>Waste Type</i>	<i>Waste Volume (cubic feet)</i>
Construction and Demolition Debris	51,000
Hazardous Waste	0
Low-level Radioactive Waste	
Low Specific Activity	37,000
Class A	310
Class B	0
Class C	0
Greater-Than-Class C Waste	0
Mixed Low-level Radioactive Waste	0
Transuranic Waste	0

Notes: The estimated waste volumes are based on commercial disposal and are presented with two significant figures. To convert cubic feet to cubic meters, multiply by 0.028317.

Source: WSMS 2009c.

C.3.3.7 Waste Management Area 7: NRC-Licensed Disposal Area and Associated Facilities

The NDA would continue to be monitored and maintained during Phase 1 of the Phased Decisionmaking Alternative. No decommissioning actions related to the NDA itself would take place in this phase of the alternative. The only Phase 1 decommissioning actions would involve removal of the remaining concrete slab and gravel pad associated with the NDA Hardstand. This work is discussed as part of WMA 9 activities in Section C.3.3.9, which also includes the removal of the pad at the NDA Trench Soil Container Area.

The disposition of the NDA and any related decommissioning actions would be reflected in the Phase 2 decommissioning plan.

Estimated Waste to be Generated

The estimated waste volumes expected to be generated during Phase 1 of the Phased Decisionmaking Alternative in WMA 7 are presented in **Table C-47**. The estimate includes wastes generated from maintenance activities only.

Table C-47 Estimated Waste to be Generated: Waste Management Area 7

<i>Waste Type</i>	<i>Waste Volume (cubic feet)</i>
Construction and Demolition Debris	2,100
Hazardous Waste	0
Low-level Radioactive Waste	
Low Specific Activity	0
Class A	22,000
Class B	0
Class C	0
Greater-Than-Class C Waste	0
Mixed Low-level Radioactive Waste	0
Transuranic Waste	0

Notes: The estimated waste volumes are based on commercial disposal and are presented with two significant figures. To convert cubic feet to cubic meters, multiply by 0.028317.

Source: WSMS 2009c.

C.3.3.8 Waste Management Area 8: State-Licensed Disposal Area and Associated Facilities

Under this alternative, active management of the SDA would continue in accordance with applicable Federal and state regulations. The associated Mixed Waste Storage Facility would remain operational. The performance of the SDA would also be assessed annually to confirm that management activities would continue to protect public health and safety and the environment. Like the NDA, the SDA would continue to be monitored and maintained during Phase 1. No action would be taken for the Waste Storage Facility.

Estimated Waste to be Generated

The estimated waste volumes expected to be generated during Phase 1 of the Phased Decisionmaking Alternative in WMA 8 are presented in **Table C-48**. The estimate includes waste generated from maintenance activities and geomembrane replacement.

Table C-48 Estimated Waste to be Generated: Waste Management Area 8

<i>Waste Type</i>	<i>Waste Volume (cubic feet)</i>
Construction and Demolition Debris	900
Hazardous Waste	0
Low-level Radioactive Waste	
Low Specific Activity	7,300
Class A	1,000
Class B	0
Class C	0
Greater-Than-Class C Waste	0
Mixed Low-level Radioactive Waste	0
Transuranic Waste	0

Notes: The estimated waste volumes are based on commercial disposal and are presented with two significant figures. To convert cubic feet to cubic meters, multiply by 0.028317.

Source: WSMS 2009c.

C.3.3.9 Waste Management Area 9: Radwaste Treatment System Drum Cell

C.3.3.9.1 Removal of the Radwaste Treatment System Drum Cell

The Drum Cell would be demolished by conventional means and the floor slab and foundation removed. It is assumed that the majority of demolition debris would be disposed of off site as construction and demolition debris. The work involved in this task is described in detail in Section C.3.1.9.

The gravel pad associated with the NDA Trench Soil Container Area would be removed to its 0.3-meter (1-foot) depth. Also, the footprint of the NDA Hardstand Area would be excavated to 0.3 meters (1 foot) below-grade, and the excavated materials would be disposed of off site as low-specific-activity waste. Surveys would be performed in the excavated areas to document conditions. After completion of the surveys, the area would be filled with appropriate clean backfill material. Sampling would also be performed to verify that hazardous constituents are below appropriate regulatory guidance levels.

The trailers in the Subcontractor Maintenance Area would be demolished by conventional means and the debris managed as construction and demolition debris waste. The gravel pad in the area would also be managed as this type of waste.

C.3.3.9.2 Estimated Waste to be Generated

The estimated waste volumes expected to be generated during Phase 1 of the Phased Decisionmaking Alternative in WMA 9 are presented in **Table C–49**.

Table C–49 Estimated Waste to be Generated: Waste Management Area 9

<i>Waste Type</i>	<i>Waste Volume (cubic feet)</i>
Construction and Demolition Debris	250,000
Hazardous Waste	0
Low-level Radioactive Waste	
Low Specific Activity	56,000
Class A	100
Class B	0
Class C	0
Greater-Than-Class C Waste	0
Mixed Low-level Radioactive Waste	0
Transuranic Waste	0

Notes: The estimated waste volumes are based on commercial disposal and are presented with two significant figures. To convert cubic feet to cubic meters, multiply by 0.028317.

Source: WSMS 2009c.

C.3.3.10 Waste Management Area 10: Support and Services Area

The Phased Decisionmaking Alternative closure approach for WMA 10 is demolition and removal of the New Warehouse, along with the remaining concrete floor slabs and foundations, during Phase 1. The Meteorological Tower, Security Gatehouse, and security fence would remain in place and operational.

C.3.3.10.1 Removal of Structures/Facilities

The New Warehouse and former Waste Management Staging Area, including the floor slabs, would be demolished, and the debris would be disposed of off site as uncontaminated construction and demolition debris.

The remaining floor slabs and foundations in the area, including those for the Administration Building, the Expanded Environmental Laboratory, the Vitrification Diesel Fuel Storage Building, and the Construction Fabrication Shop, would be removed. After completion of this work, radiological surveys and RCRA confirmatory sampling would be performed in each excavated area to document conditions. After completion of the surveys, the excavated areas would be filled with appropriate clean backfill material and contoured to grade.

C.3.3.10.2 Estimated Waste to be Generated

The estimated waste volumes expected to be generated during Phase 1 of the Phased Decisionmaking Alternative in WMA 10 are presented in **Table C-50**.

Table C-50 Estimated Waste to be Generated: Waste Management Area 10

<i>Waste Type</i>	<i>Waste Volume (cubic feet)</i>
Construction and Demolition Debris	59,000
Hazardous Waste	0
Low-level Radioactive Waste	
Low Specific Activity	0
Class A	0
Class B	0
Class C	0
Greater-Than-Class C Waste	0
Mixed Low-level Radioactive Waste	0
Transuranic Waste	0

Notes: The estimated waste volumes are based on commercial disposal and are presented with two significant figures. To convert cubic feet to cubic meters, multiply by 0.028317.
Source: WSMS 2009c.

C.3.3.11 Waste Management Area 11: Bulk Storage Warehouse and Hydrofracture Test Well Area

No decommissioning activities would take place in WMA 11 during Phase 1 of the Phased Decisionmaking Alternative. As a result, no waste would be generated.

C.3.3.12 Waste Management Area 12: Balance of Site

During Phase 1 of the Phased Decisionmaking Alternative, the dams and reservoirs would continue to be monitored and maintained. Parking lots and roadways would remain in place. Surface soils and sediments would be characterized and evaluated for remediation.

C.3.3.12.1 Remediation of Surface Soils and Sediments

Surface soil and sediment having radioactivity concentrations in excess of the DCGLs specified in the *Decommissioning Plan* may be remediated during Phase 1 decommissioning work. This includes soils and sediments outside those areas being removed or maintained during Phase 1 decommissioning (e.g., Main Plant

Process Building, Waste Tank Farm, North Plateau Groundwater Plume, Low-Level Waste Treatment Facility, NDA, and SDA). An initial action during Phase 1 of the Phased Decisionmaking Alternative would be additional radiological characterization of soil contamination. The characterization data would allow more precise decisionmaking regarding the location of contaminated soils and the extent of removal.

During Phase 1, surface soils and stream sediment to be addressed may be remediated to meet criteria for unrestricted release either immediately or after a period of decay. The determinations would be consistent with NRC License Termination Rule criteria and Federal and state cleanup criteria, as applicable. For analysis purposes, an estimate of soil volume to be removed has been made, but the estimate is based on limited characterization data and is considered to be conservative. The estimate was based on a removal depth of 0.6 meters (2 feet).

C.3.3.12.2 Estimated Waste to be Generated

The estimated waste volumes expected to be generated during Phase 1 of the Phased Decisionmaking Alternative in WMA 12 are presented in **Table C–51**. The estimate includes waste that would be generated from miscellaneous sitewide activities, including environmental monitoring installations, security installations, annual environmental monitoring, and existing facility maintenance. Although portions of these wastes could be generated in other areas of the site, they are included in the WMA 12 totals.

Table C–51 Estimated Waste to be Generated: Waste Management Area 12

<i>Waste Type</i>	<i>Waste Volume (cubic feet)</i>
Construction and Demolition Debris	29,000
Hazardous Waste	180
Low-level Radioactive Waste	
Low Specific Activity	240,000
Class A	75,000
Class B	0
Class C	0
Greater-Than-Class C Waste	0
Mixed Low-level Radioactive Waste	0
Transuranic Waste	0

Notes: The estimated waste volumes are based on commercial disposal and are presented with two significant figures. To convert cubic feet to cubic meters, multiply by 0.028317.
Source: WSMS 2009c.

C.3.3.13 North Plateau Groundwater Plume

Decommissioning activities associated with the source area of the North Plateau Groundwater Plume would be the same as those described for the Sitewide Removal Alternative. They are described in Section C.3.1.1.8. The existing North Plateau Groundwater Recovery System and related equipment would be left in place in a standby condition. The nonsource area of the plume would be contained by the permeable treatment wall installed for the starting point of the EIS. The estimate of the waste that would be generated from the source area of the North Plateau Groundwater Plume is included in the estimate for WMA 1. The estimated waste volumes to be generated from the maintenance of the nonsource area of the North Plateau Groundwater Plume are presented in **Table C–52**. The waste volumes are entirely due to the periodic replacement of the permeable treatment wall.

Table C-52 Estimated Waste to be Generated: North Plateau Groundwater Plume (nonsource area)

<i>Waste Type</i>	<i>Waste Volume (cubic feet)</i>
Construction and Demolition Debris	0
Hazardous Waste	0
Low-Level Radioactive Waste	
Low Specific Activity	71,000
Class A	310
Class B	0
Class C	0
Greater-Than-Class C Waste	0
Mixed Low-level Radioactive Waste	0
Transuranic Waste	0

Note: The estimated waste volumes are based on commercial disposal and are presented with two significant figures. To convert cubic feet to cubic meters, multiply by 0.028317.
Source: WSMS 2009c.

C.3.3.14 Cesium Prong

The Cesium Prong would be managed in place during Phase 1 of the Phased Decisionmaking Alternative. As a result, no waste would be generated from the management of the Cesium Prong.

C.4 Construction of New Facilities/Structures

Section C.4 provides detailed descriptions of facilities and structures that would need to be constructed or installed and to support decommissioning activities under various EIS alternatives. An overview of the facilities and structures needed to support each alternative is provided in **Table C-53**.

The modification of existing facilities was considered in lieu of new construction for the Interim Storage Facility (Dry Cask Storage Area), the Waste Tank Farm Waste Processing Facility, the Soil Drying Facility, the Container Management Facility, and the Leachate Treatment Facility. The rationale for each new facility is provided in the following paragraphs. Detailed descriptions of the proposed new facilities and other construction necessary to support the implementation of the alternatives are presented in Sections C.4.1 through C.4.13.

Interim Storage Facility (Dry Cask Storage Area) in Waste Management Area 6

The Interim Storage Facility would be constructed to safely and securely store the high-level radioactive waste canisters until disposition decisions are made and implemented. The facility would be constructed under the Sitewide Removal, Sitewide Close-In-Place, and the Phased Decisionmaking Alternatives. To tear down the Main Plant Process Building and the Vitrification Facility, the canisters need to be removed and placed elsewhere on site. The storage concept is patterned on spent nuclear fuel dry storage installations licensed by the NRC. To provide the necessary space, a concrete pad just under 0.4 hectare (1 acre) in size would be needed.

One existing facility that appeared to be a candidate for long-term storage of the vitrified high-level radioactive waste canisters was the Vitrification Facility Cell. However, it was not used to provide flexibility for decommissioning that portion of the site and to provide access to the North Plateau Groundwater Plume source area. Use of the Drum Cell was also considered, but it would require major work on the pad, and the layout and dimensions are not the most efficient.

Table C–53 Proposed New Construction Under Each Action Alternative

<i>Facility/Structure</i>	<i>Section</i>	<i>Sitewide Removal Alternative</i>	<i>Sitewide Close-In-Place Alternative</i>	<i>Phased Decisionmaking Alternative (Phase 1)</i>
Interim Storage Facility (Dry Cask Storage Area) in WMA 6	C.4.1	x	x	x
Waste Tank Farm Waste Processing Facility in WMA 3	C.4.2	x		
Soil Drying Facility in WMA 6	C.4.3	x		
Container Management Facility in WMA 9	C.4.4	x		
Leachate Treatment Facility in WMA 9	C.4.5	x	x	
Environmental Enclosures and Confinement Structures for Exhumation of NDA, SDA, Lagoon 1 in WMA 2, and the North Plateau Groundwater Plume Source Area	C.4.6	x		
Main Plant Process Building Excavation Downgradient Barrier Wall in WMA 1	C.4.7	x		x
Circumferential Hydraulic Barrier around WMA 1 and WMA 3 and Multi-layer Cap	C.4.8		x	
Multi-layer Cover over WMA 2 lagoons	C.4.9		x	
Barrier Wall in WMA 2	C.4.10			x
Multi-layer Covers over NDA and SDA	C.4.11		x	
Circumferential Barrier Wall in WMA 2 for Lagoon 1	C.4.12		x	
Erosion Control Structures	C.4.13		x	

NDA = NRC [U.S. Nuclear Regulatory Commission]-Licensed Disposal Area; SDA = State-Licensed Disposal Area;
WMA = Waste Management Area.
Sources: WSMS 2009a, 2009b, 2009c, 2009e.

The facility would be placed on the South Plateau within WMA 6 to be closer to the rail line and away from the facilities and decommissioning activities on the North Plateau. There are no existing facilities that could be used without significant upgrades or additions, so it is believed that building a new storage area is the most efficient means of providing the most cost-effective solution.

Waste Tank Farm Waste Processing Facility in Waste Management Area 3

A facility would be constructed under the Sitewide Removal Alternative to be used for the treatment, stabilization, packaging, and characterization of the residual radionuclide inventory in the Waste Tank Farm.

The Waste Tank Farm Waste Processing Facility would be a robust shielded structure built over the Waste Tank Farm in WMA 3 equipped with all the required components to complete the removal of the highly radioactive waste tanks. Based on the form and amount of radioactive material that would be handled, processed, and packaged for disposal and the potential impacts on workers and the public, a single robust structure within which all the closure processes would be performed in an integrated manner would be most efficient in protecting the health and safety of the workers and the public.

Estimates have shown that removing the surface soil and the top of the vaults from above the tanks would result in unacceptably high exposure rates in the Waste Tank Farm Area. The thickness of the concrete walls and roof of the Waste Tank Farm Waste Processing Facility have been selected to reduce the Waste Tank Farm Area exposure rate, due to the residual tank activity, to unrestricted access levels (e.g., less than 5 millirem per hour). In addition to providing shielding, the Waste Tank Farm Waste Processing Facility must function as a confinement structure to contain airborne material expected to be generated during the cutting of the tanks.

Consideration was also given to using an existing facility like the Remote-Handled Waste Facility for the packaging portion of the Waste Tank Farm mission. Usage of the Remote-Handled Waste Facility for this partial mission would still require the construction of a processing facility at the tank disassembly site, as well as transportation considerations between the facilities. Performing the entire mission, including packaging, at the tank site is considered to be more cost-effective and safer than using separate facilities for tank removal and waste packaging.

Soil Drying Facility in Waste Management Area 6

A facility would be constructed under the Sitewide Removal Alternative to support dewatering/drying and packaging of contaminated soil and sediment to be excavated from the North Plateau Groundwater Plume, the CDDL, and WMA 12 (stream sediment removal). This facility is not required under the Phased Decisionmaking Alternative due to the lower volume of excavated soils; high-capacity absorbent materials would be added to the disposal containers instead.

Due to the large volume of contaminated soils that would be generated during excavation of the entire North Plateau Groundwater Plume and other miscellaneous areas on the North Plateau, there is an advantage in locating the new Soil Drying Facility near the Rail Spur. The area selected is located just south of the southern portion of the plume, thereby providing a single area for staging, processing, and loading soils that is outside of contaminated areas and adjacent to the Rail Spur. Using an existing facility like the Remote-Handled Waste Facility would require transporting soils to several areas for processing and loading or extending the Rail Spur. Therefore, no existing facility was given further consideration as it is considered more efficient to construct a new facility where all the functions can be performed at a single location.

Container Management Facility in Waste Management Area 9

A facility would be constructed under the Sitewide Removal Alternative to provide the processes needed to support the excavation of the NDA and SDA. The facility would also be used for storage of potential orphan wastes.

The Drum Cell is not large enough to house all the functional needs of the Container Management Facility and would require significant modification and upgrades to the already 20-year old facility to use it to support the functions of the Container Management Facility. Under the Sitewide Removal Alternative, it would be advantageous to have a single location to consolidate all wastes that might require interim storage. This would make monitoring and maintenance activities the most efficient. Because the greatest quantities of such wastes would come from the NDA and the SDA, and because a single location on the South Plateau would allow all facilities and operations to be removed from the North Plateau, using a single new facility on the South Plateau would be the most efficient approach.

Leachate Treatment Facility in Waste Management Area 9

A facility would be constructed to treat the leachate that would be pumped from the NDA and SDA disposal areas to support both the Sitewide Removal and Sitewide Close-In-Place Alternatives. Available information indicates that the facility would need to provide treatment for both radiological and hazardous constituents before the effluent could be discharged. To minimize transfer distances and the potential for environmental impacts, a new facility located between the NDA and SDA is the preferred option. No existing facility has all the components needed for performing the treatment that would be required. The Low-Level Radioactive Waste Treatment Facility on the North Plateau is designed to treat certain radionuclides but is not large enough to house all the components needed to treat leachate from the disposal areas. Use of this facility to support SDA and NDA removal would require transferring the highly contaminated liquids a much greater distance. It is conceivable that some components of the NDA liquid pretreatment system could be used; however, these

components are nearly 30 years old and may not be easily compatible with the currently envisioned leachate treatment system.

C.4.1 Interim Storage Facility (Dry Cask Storage Area) in Waste Management Area 6

The Interim Storage Facility would be used to temporarily store the 275 vitrified high-level radioactive waste canisters from WMA 1 until disposition decisions are made and implemented. The Load-In/Load-Out Facility in WMA 1 would be converted to a Load-Out Facility to support the removal of the vitrified high-level radioactive waste canisters from the Main Plant Process Building and transfer them to the Interim Storage Facility. The equipment to be installed in the facility would include a shielded transfer cell, a canister handling system to extract the canisters from the shielded transfer cell and to place them into storage casks, and a high-capacity crane. The Load-Out Facility would be demolished once all the vitrified high-level radioactive waste canisters have been removed from the Main Plant Process Building (WSMS 2009e).

The design of the Interim Storage Facility would be patterned on spent nuclear fuel dry storage installations currently licensed by the NRC, which are designed to meet 10 CFR 72, “Licensing Requirements for the Independent Storage of Spent Nuclear Fuel, High-level Radioactive Waste, and Reactor Related Greater-Than-Class C Waste.” The Interim Storage Facility will be designed to withstand events such as seismic activity or atmospheric phenomena. The design life of the dry cask storage system proposed for the site is 50 years. The storage area would measure approximately 113 meters by 33.5 meters (370 feet by 110 feet). The vitrified high-level radioactive waste canisters would be transferred into casks, which would be placed into horizontal storage modules, ensuring adequate shielding and mechanical protection. The Interim Storage Facility would be located in WMA 6 on the South Plateau adjacent to the southwest edge of the NDA, as shown on **Figure C-16**.

Up to seven canisters would be moved within a single cask; each cask would be moved completely within a period of approximately 40 hours of work. This estimate is based on experience gained during the removal and placement of material with high and very high dose rates (greater than 100 milliroentgen per hour) contained in lead-shielded containers at Brookhaven National Laboratory and Oak Ridge National Laboratory and compares favorably with the *Diablo Canyon Independent Spent Fuel Storage Installation Safety Analysis Report* (PG&E 2002) estimate of time required for similar activities (17 hours for transferring a loaded cask to the Independent Spent Fuel Storage Installation). While these events are similar to those proposed for the high-level radioactive waste canister transfer, there are differences in loading configuration and waste disposition that could affect duration and cost estimates.

For security purposes, two fences, one of chain link and one of razor wire, would be constructed around the perimeter of the area. Additional lighting and remote monitoring equipment would be installed as necessary. The Interim Storage Facility would be decontaminated and demolished after the high-level radioactive waste canisters have been removed for disposition.

C.4.2 Waste Tank Farm Waste Processing Facility in WMA 3

Under the Sitewide Removal Alternative, decommissioning of WMA 3 would require the removal of a residual radionuclide inventory from the tanks, followed by the demolition and removal of the contaminated tank shells and their associated vaults. The removed inventory would need to be treated, stabilized, packaged, and characterized before disposal. The tank shells would need to be reduced in size, packaged, and characterized before disposal. These operations would be performed in the Waste Tank Farm Waste Processing Facility, a 104- by 84-meter (340- by 275-foot) robust, shielded structure built over the Waste Tank Farm Area (WMA 3) that would be equipped with the required infrastructure to complete the proposed closure activities. The location of the Waste Tank Farm within WMA 3 is shown on Figure C-3.

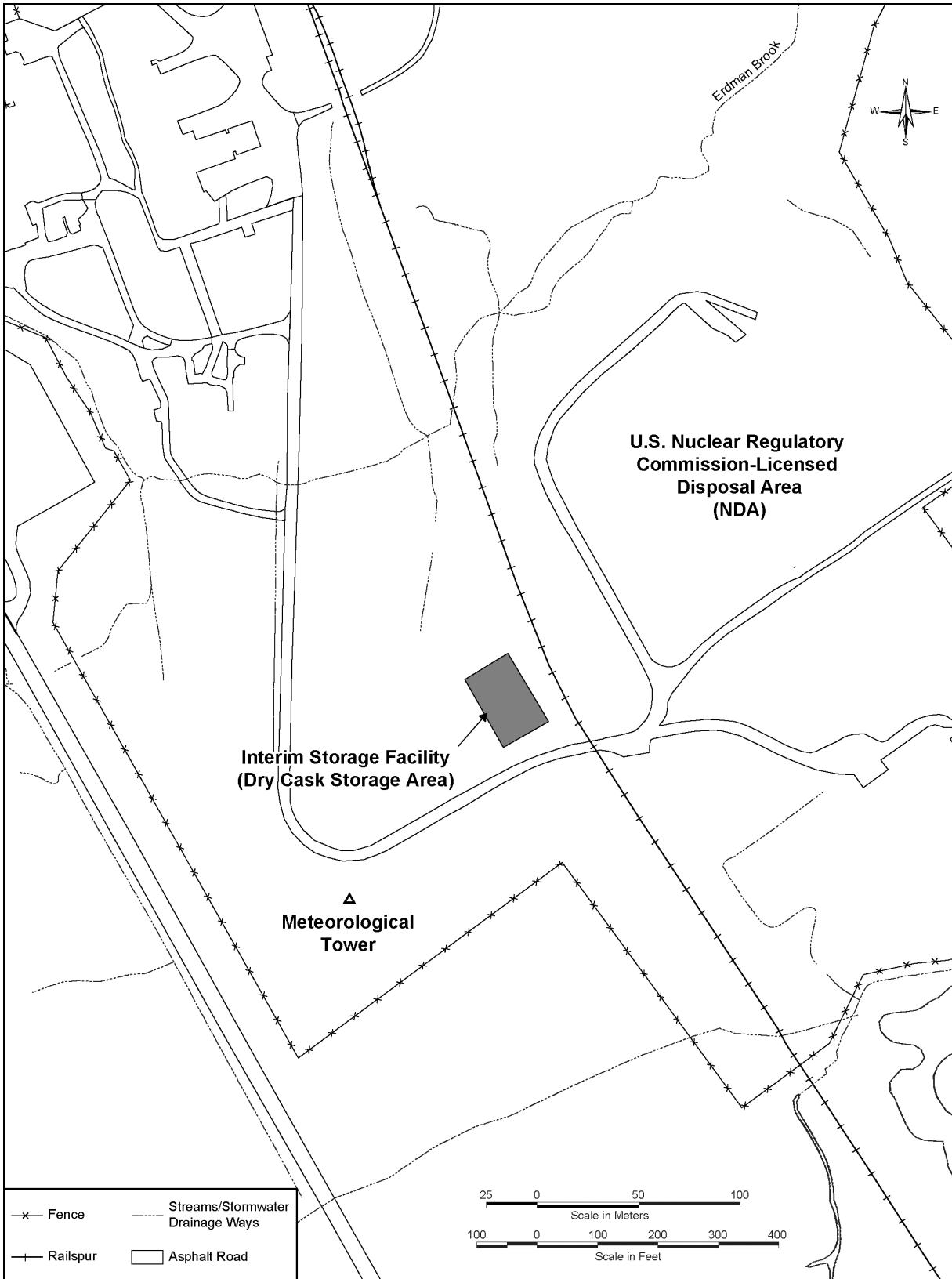

**Figure C-16 Location of the Interim Storage Facility (Dry Cask Storage Area)
in Waste Management Area 6**

Guidance for the design of facilities used to process radioactive materials is provided in DOE Standard 1021-93, *Natural Phenomena Hazards Performance Categorization Guidelines for Structures, Systems, and Components* (DOE 1996b). Based on the form and amount of radioactive material to be processed in the Waste Tank Farm Waste Processing Facility and on the likely consequences to workers and members of the public in the event of an accident in the facility, it is expected that the Waste Tank Farm Waste Processing Facility would be categorized as a Performance Category 2 facility using the guidance in Standard 1021-93. In general, Performance Category 2 facilities are designed to conform to the requirements of the International Building Code. However, certain elements of facility design may be enhanced to provide a greater degree of hazard protection. Enhancements, where necessary, are discussed in the rest of this section.

Pressure differentials would be maintained between each confinement zone so that airflow travels from zones of lesser contamination potential to zones of greater contamination potential. The Waste Tank Farm Waste Processing Facility ventilation system would ensure positive confinement of airborne radioactive material.

The air from all spaces would be filtered using a minimum of two fire-resistant HEPA filters in series before discharge to the environment. Redundant exhaust blower capability would be provided, and additional HEPA filter train(s) would be provided to allow for the maintenance and testing of a given HEPA filter train. The Waste Tank Farm Waste Processing Facility would be equipped with diesel generators housed in the warehouse to provide emergency standby electrical power to the appropriate motor control center(s) to ensure that power to Waste Tank Farm Waste Processing Facility ventilation system components could be provided in the event of a loss of offsite power.

The Waste Tank Farm Waste Processing Facility would be a freestanding reinforced concrete and steel structure enclosed within an exterior sheet metal weather structure providing approximately 4,650 square meters (50,000 square feet) of confinement over Tanks 8D-1, 8D-2, 8D-3, and 8D-4 and their associated structures. The Waste Tank Farm Waste Processing Facility also includes 1,100 square meters (12,000 square feet) of office/project support space and a 3,070-square-meter (33,000-square-foot) loading and transport wing. The maximum overall dimensions would be approximately 104 meters (340 feet) in length and 84 meters (275 feet) in width. The facility would be 26 meters (87 feet) high at its roof peak. The facility would be constructed primarily of cast-in-place reinforced concrete up to 1.5 meters (5 feet) in thickness for radiological shielding purposes and would be supported by a foundation on H-piles driven to a depth of at least 15.2 meters (50 feet) into the underlying geologic material.

Demolition and waste processing, packaging, and shipping activities would be performed or supported in the following areas within the Waste Tank Farm Waste Processing Facility:

- Waste Tank Farm Confinement Area
- Liquid Waste Process Cell
- Remote-Handled Work Cell
- Sampling and Observation Aisle
- Waste Package Decontamination Area
- Nondestructive Assay Cell
- Remote-Handled Cask Loading Cell
- Transport Loading Area
- Shipping Depot
- Control Room
- Facility Support Areas

The Waste Tank Farm Waste Processing Facility would be demolished after the post-excavation survey is completed, and the excavation would be filled with appropriate clean backfill material. The enclosure would be demolished by conventional demolition equipment such as hydraulic excavators equipped with demolition hammers and shears. The demolition debris would be packaged as low-specific-activity waste and transported to an offsite low-level radioactive waste disposal facility. The equipment would be packaged as Class A low-level radioactive waste and also would be disposed of off site.

Once the facility has been removed, any contaminated soil generated during demolition would be removed and disposed of as low-specific-activity waste. A final status survey would be performed in the area impacted by demolition of the enclosure to establish that residual radioactivity levels do not exceed the established DCGLs. RCRA confirmatory sampling would also be performed. Additional clean soil backfill would be placed and the area graded to a near natural appearance.

C.4.3 Soil Drying Facility in Waste Management Area 6

The Soil Drying Facility would support packaging of contaminated soil and sediment excavated from the North Plateau Groundwater Plume. It would be a new facility located just south of the southern portion of the North Plateau Groundwater Plume, near the Rail Spur. The Soil Drying Facility would consist of a 4,600-square-meter (50,000-square-foot) pad housing the process equipment, an 8,200-square-meter (88,000-square-foot) Dry Soil Shelter Building, and 1,800 linear meters (6,000 linear feet) of Rail Spur tracks and gondola car storage.

The major items of process equipment in the Soil Drying Facility would include a feed bin, conveyor, rotary dryer, soil cooler, radial soil stacker, off-gas baghouse, HEPA filters, thermal oxidizer, and stack.

The Soil Drying Facility would be demolished and removed after the North Plateau Groundwater Plume (including the source area), the CDDL, the Main Plant Process Building, and the WMA 2 areas have been excavated. The debris generated from the demolition would be packaged as low-specific-activity waste and disposed of off site at a low-level radioactive waste disposal facility.

C.4.4 Container Management Facility in Waste Management Area 9

The Container Management Facility would be a new facility, as shown on **Figure C-17**, and would be located along the Rail Spur on the South Plateau, as shown on **Figure C-18**. It would be capable of receiving the wastes in an “as excavated” form, drying them, sorting them, reducing the size of larger items, recompacting wastes that were “bulked-up” during excavation, packaging them, decontaminating the packages, classifying them, temporarily storing them, and loading them onto trucks or railcars for offsite transport. It would also be capable of receiving wastes in packaged form; decontaminating the packages, if necessary; classifying them; temporarily storing them; and loading them onto trucks or railcars for offsite transport. The Container Management Facility would also contain an area for the storage of potential orphan waste, including Greater-Than-Class C waste, pre-project Class B and C low-level radioactive waste, and transuranic waste generated under the Sitewide Removal Alternative. Pre-project waste is waste that was buried before DOE assumed control of a portion of the site and would, therefore, not be disposed of at a DOE disposal facility such as the Nevada Test Site.

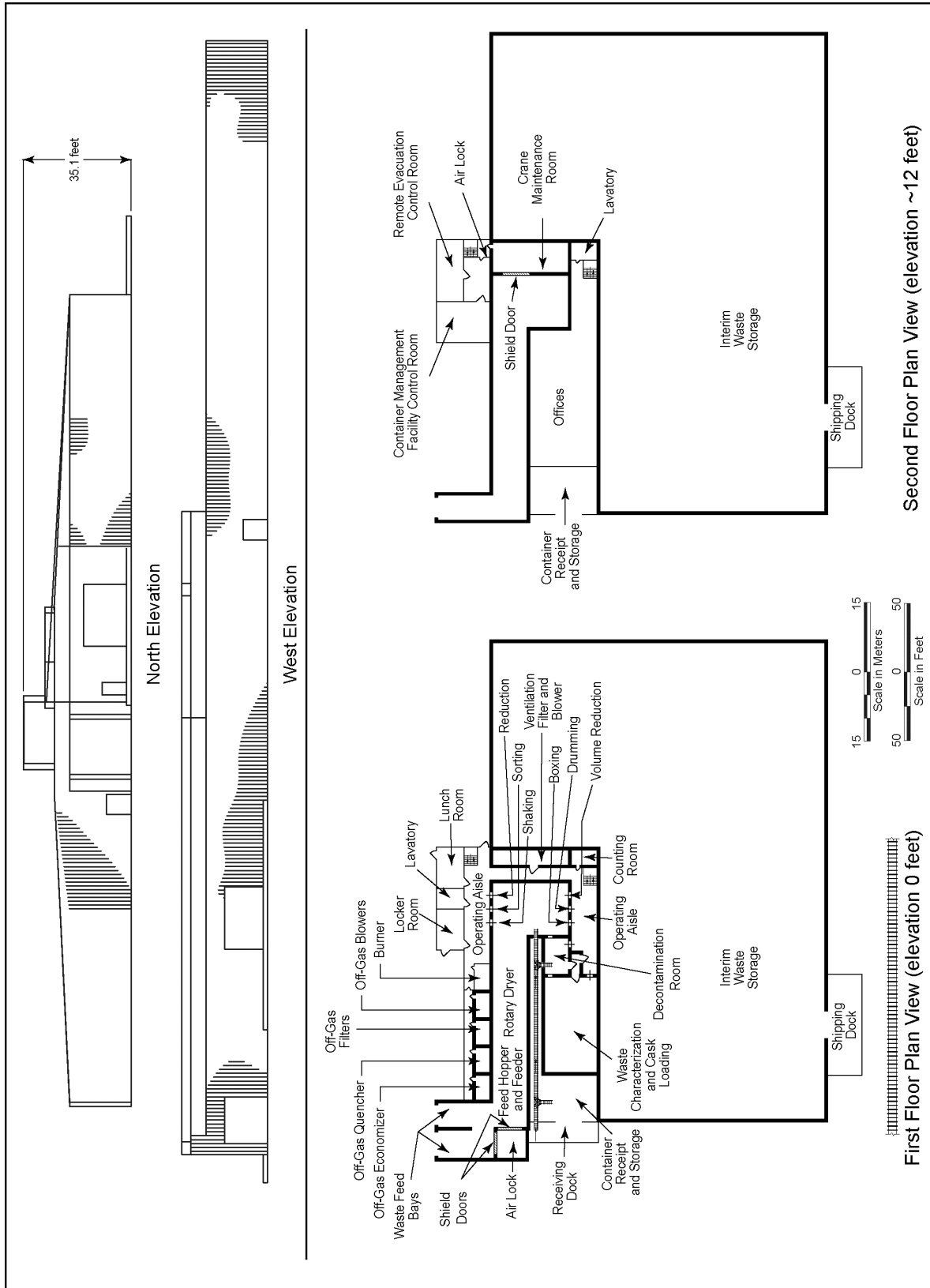

Figure C-17 Conceptual Container Management Facility in Waste Management Area 9 – Elevation and Plan View

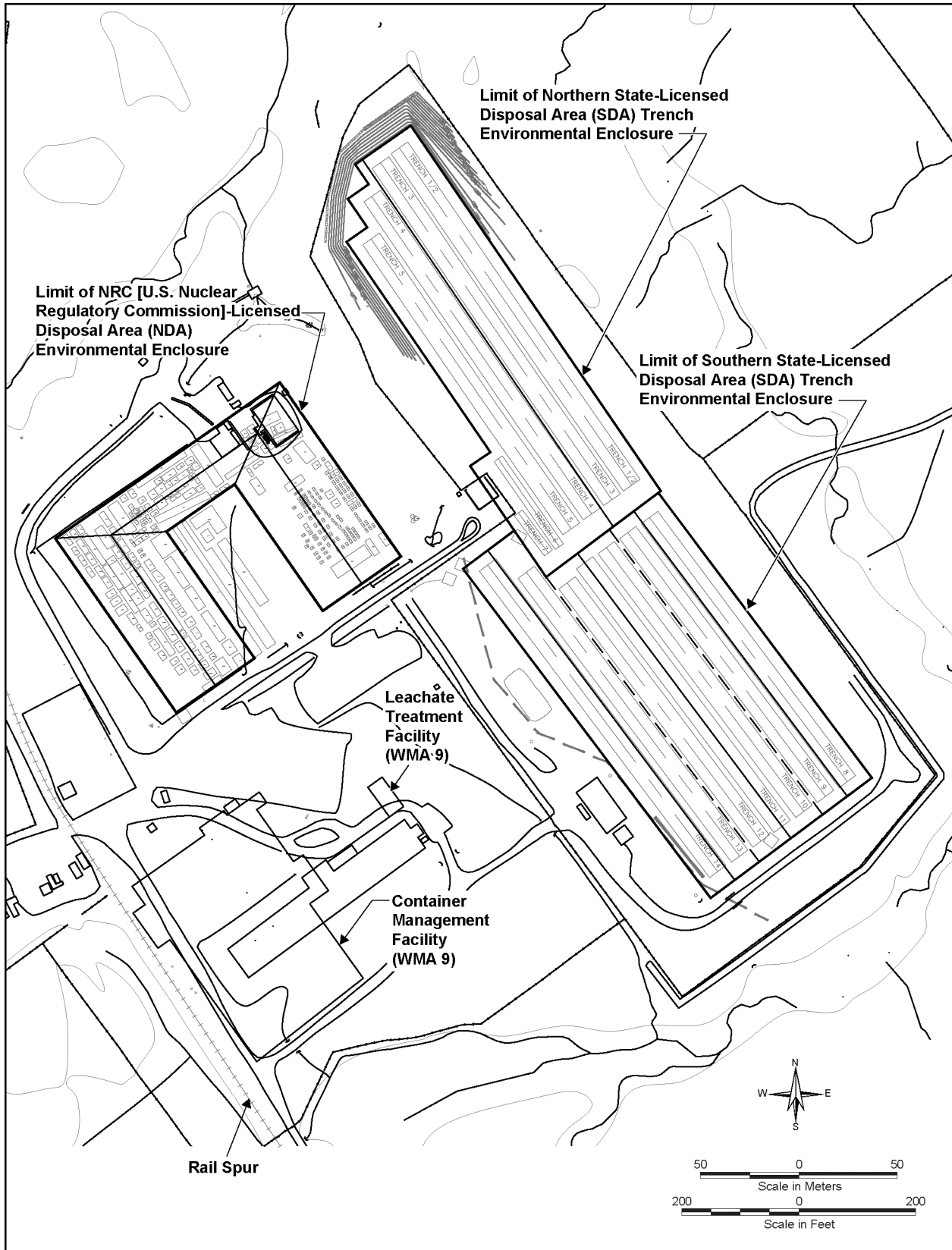

Figure C-18 Locations of Container Management and Leachate Treatment Facilities in Waste Management Area 9

The Container Management Facility is a conceptual structure with dimensions designed according to the space needed for processing and potentially storing large volumes of waste. The geometry of the Container Management Facility is flexible, with the most critical features of the design being the relatively small process area and the space required for the process equipment. The location of the Container Management Facility is also flexible, provided that it is sited in relative proximity to the NDA and SDA and allows for the efficient movement of wastes from the burial areas to the facility. The footprint of the Container Management Facility is anticipated to occupy some of the space that is currently occupied by the Drum Cell building, because the Sitewide Removal Alternative implementation schedule has the Drum Cell being removed prior to construction of the Container Management Facility. However, there is a potential for the Drum Cell to be used for decommissioning purposes (i.e., storage area, laydown area) during the course of the Sitewide Removal Alternative for which the timing might overlap with the schedule for construction and operation of the Container Management Facility. In this case, the Container Management Facility storage area configuration might be revised to allow for construction and operation of the facility prior to demolition of the Drum Cell. The variations that are envisioned as a result of the reconfiguration would have negligible effect on the overall costs and impacts.

The Container Management Facility considered in the Sitewide Removal Alternative was designed with sufficient open storage space to adequately store all Greater-Than-Class C waste and commercial Class B and C low-level radioactive waste generated from the NDA and SDA. The conceptual Container Management Facility is also adequately sized to allow temporary storage of the transuranic wastes generated during removal of WMA 3 and dismantlement of the high-level radioactive waste tanks.

The Container Management Facility would be a radiological facility with reinforced concrete shield walls around processing and storage areas and a steel frame and steel cladding in other areas. The floors and foundations would be constructed of reinforced concrete, and the roofs would be constructed of concrete with asphalt roofing. The conceptual layout of the facility was created with a portion of the building in a two-story configuration: the processing, containerizing, and characterization areas on the first floor and office space on the second floor. The footprint of this section of the building was designed to be approximately 1,560 square meters (20,000 square feet).

The remainder of the conceptual facility was designated for interim storage of commercial Class B and C low-level radioactive waste, Greater-Than-Class C waste, and transuranic waste. This portion of the building was designed as a single-story, warehouse-type structure that contains a floor area of 6,500 square meters (70,000 square feet).

The inside surfaces of the shielded work area would be lined to facilitate decontamination. The floor and lower levels of the walls subject to impact from crane-carried loads would be lined with stainless steel. The upper levels of the walls and the ceilings would be covered with a strippable paint.

The building would be equipped with a HEPA-filtered ventilation system, independent from the process off-gas system. This ventilation system would be designed for heating, ventilation, air conditioning, and contamination control. The ventilation system would discharge to the same stack as the off-gas treatment system.

Because the Container Management Facility would be used to process waste that would contain fission products and transuranic radionuclides, the facility would be designed and built to meet the requirements of a Performance Category 3 structure (as defined by DOE Standard 1020-2002). It would be capable of withstanding design-basis natural hazards, such as earthquakes, high winds, and snow loading (DOE 1996b).

The facility would contain a waste dryer, off-gas treatment equipment, dry waste processing equipment, decontamination room, waste characterization equipment, and waste loading and transport equipment. An

Interim Waste Storage Area would be sized to provide temporary storage for all Greater-Than-Class C wastes expected to be exhumed from the NDA and SDA. The facility would also contain adequate storage space for the pre-project Class B and Class C low-level radioactive waste removed from the NDA and SDA. These wastes would be stored in this facility until a disposal facility becomes available to accept them. The building would be demolished after all wastes have been removed from the Interim Waste Storage Area.

Demolition of the Container Management Facility would result in the generation of a variety of waste streams ranging from construction and demolition debris waste through Class A low-level radioactive waste. The demolition process would include appropriate measures for facility areas and components based on their respective operational histories.

Decommissioning activities would include surveying and characterizing contaminants, conducting mechanical decontamination, removing and segmenting stainless steel liner systems and process equipment, and using spray fixatives. Foundations are assumed to be uncontaminated. The waste generated from decommissioning activities is assumed to be managed as construction and demolition debris waste.

The exterior surfaces of the waste handling equipment and the interior surfaces of the rotary drum dryer would be decontaminated using mechanical decontamination methods, such as carbon dioxide pellet decontamination. A spray fixative would be applied after decontamination. The equipment would be dismantled and reduced in size, as necessary. The dryer, shaker table, and sorting tables would be reduced in size in place using cutting equipment, such as plasma arc torches. The resulting equipment segments and the stainless steel liner would be packaged and transported off site for disposal as Class A low-level radioactive waste.

The interior surfaces of the building would be sprayed with fixative to allow for demolition without confinement. The structure would be demolished by conventional methods. The debris would be packaged as low-specific-activity waste and transported off site for disposal.

The conceptual Container Management Facility proposed for NDA and SDA remediation is considered first of its kind. There are no full-scale field examples of waste retrieval and processing operations of this magnitude and involving the waste classes that would be dealt with under the Sitewide Removal Alternative. The anticipated wastes have been listed based on historic documentation. However, there exists a significant potential to discover wastes and types that are unexpected or unplanned. The costs of construction of the facilities would be fairly reliable (within the contingency specified in the estimates), as the structural and equipment components are readily available and have been used in some capacity in the past. However, the project productivity and safety are items of uncertainty that cannot be easily estimated.

One component of the waste retrieval process that involves a high level of uncertainty is the retrieval of wastes from the NFS deep holes, using primarily a telescoping boom with various tools. Conceptually, this equipment would be able to work vertically at depth, using different end attachments to scan, excavate, cut, and vacuum the waste materials and bring the wastes to the surface. However, this process has not been demonstrated in a full-scale field environment.

C.4.5 Leachate Treatment Facility in Waste Management Area 9

A Leachate Treatment Facility would be designed and constructed to treat leachate generated during the NDA and SDA waste removal activities and the 28,390 liters (7,500 gallons) of leachate stored in the Mixed Waste Storage Facility. The Leachate Treatment Facility is expected to include a 37-square-meter (400-square-foot) leachate storage building, a 176-square-meter (1,900-square-foot) Shielded Treatment Building, and a 209-square-meter (2,250-square-foot) treated water storage building/laboratory.

The facility would be constructed near the new Container Management Facility to house the treatment equipment (see Figure C–18). The facility would be able to treat organic chemicals and dissolved radionuclides in the leachate. However, it would not be able to remove or treat tritium in the leachate. A plan view of the Shielded Treatment Building, the operational component of the Leachate Treatment Facility, is shown on **Figure C–19**. The water storage facilities are not shown.

The facility would be operated on demand and, based on the limiting productivity of the waste removal process, would be expected to process an average of 3,800 liters (1,000 gallons) of leachate per day. It is assumed to be operated 8 hours per day during the waste removal work. The treatment process would consist of a leachate hold tank, a bioreactor, a mechanical filter, an activated carbon polisher, and ion-exchange columns. The components of the facility that are used to manage raw leachate, including the raw leachate storage tank and the primary process equipment, would be constructed inside of a building intended to provide appropriate shielding between these components and the environment.

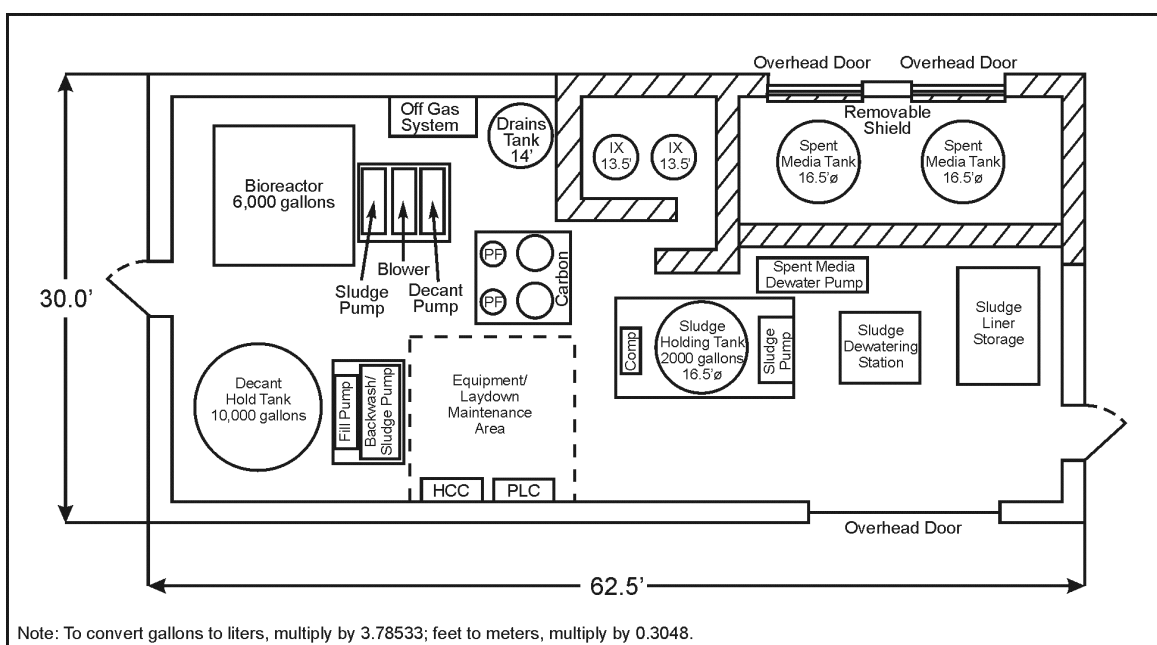

Figure C–19 Conceptual Leachate Treatment Facility in Waste Management Area 9 – Plan View

The principal components of the Leachate Treatment Facility are:

- The 34,000-liter (9,000-gallon) raw (untreated) leachate hold tank – The leachate hold tank would be installed in a shielded enclosure, separate from the treatment process as well as the treated leachate storage tanks. Leachate pumped from the hold tank would be filtered using mechanical filtration prior to introduction to the treatment train;
- The bioreactor – This component would be used to treat the organic chemicals in the leachate. The reactor would be operated on a batch basis and would employ aeration with agitation, settling, and decanting. The sludge from the bioreactor would be transferred to a sludge hold tank for processing, packaging, and disposal;
- The ion-exchange columns – This component would be used to remove most of the dissolved radionuclides from the leachate, and would employ an inorganic ion-exchange material to remove the two principal radionuclides of concern, cesium-137 and strontium-90;

- Mechanical Filter and Carbon Beds – The decanted leachate in the hold tank would be passed through fine filters to remove entrained solids prior to introduction of the leachate into the activated carbon polisher beds, thereby preventing plugging of the beds. The activated carbon polisher would be used to remove any remaining organic material that was not removed by operation of the bioreactor;
- The effluent from the carbon beds would be directed to the treated water storage tanks. The treated leachate in these tanks would be sampled and analyzed before being directed either to the Low-Level Waste Treatment Facility lagoons for final treatment and/or discharge through a SPDES-permitted discharge, or back into the Leachate Treatment System to be “reworked”; and
- Off-Gas Treatment – Off-gases from the bioreactor would be treated by (1) mist elimination to remove entrained droplets, (2) heating to reduce the relative humidity for purposes of protecting downstream equipment, (3) HEPA filtration to remove radiologically contaminated particulate matter, and (4) carbon adsorption to remove organic vapors. An off-gas blower would keep the process under negative pressure for contamination control.

The Leachate Treatment Facility would be decommissioned and demolished upon completion of the WMA 7, WMA 8, and/or other potential emergent site activities that require its support. The treatment system would be flushed to purge residual leachate and wastewater. The zeolite ion-exchange media would be removed from the vessels and managed as Class C low-level radioactive waste. The treatment equipment would be removed, segmented, and managed as Class A low-level radioactive waste. The Leachate Treatment Facility Building would be demolished using typical site protocols, and the structural components of the building, including concrete, would be managed as low-specific-activity waste.

C.4.6 Environmental Enclosures and Confinement Structures

Environmental enclosures and confinement structures would be constructed over the NDA and SDA, Lagoon 1 in WMA 2, SDA lagoons, and the North Plateau Groundwater Plume source area to support removal of buried waste or contaminated soils for the Sitewide Removal Alternative. Some of these structures would not be movable while others would be modular with the capability of being deconstructed and moved to different disposal locations. These structures are described in the following subsections.

The analysis in this EIS assumes that these structures would eventually be demolished with all resulting debris characterized and appropriately disposed of. However, waste minimization practices would be used to minimize disposal volumes as much as practical. By using modular structures as much as possible, secondary waste would be avoided. At the end of the exhumation projects, all enclosures would be surveyed, and if feasible, section of the enclosures would be released and available for reuse consistent with DOE requirements. If it is not technically or economically feasible to release sections of the enclosures, waste volumes would be minimized through size reduction techniques including cutting, compaction, or pulverizing (e.g., concrete).

C.4.6.1 NRC-Licensed Disposal Area Environmental Enclosure

A confinement structure, called the NDA Environmental Enclosure, would be constructed over all waste burial holes in WMA 7 suspected of containing wastes classifiable as being greater than Class A low-level radioactive waste. It would be constructed over the NFS deep holes, NFS special holes, and WVDP Trenches 1 through 7. It would be designed as a Performance Category 3 structure (as defined by DOE Standard 1020-2002) and would withstand design-basis natural hazards, such as earthquakes, high winds, and snow loading (DOE 1996b). A Performance Category 3 structure is designed to include such elements as a “Tornado Missile Barrier,” involving substantial walls and roof. The conceptual NDA Environmental Enclosure is shown on **Figure C-20**. WVDP Trenches 8 through 12 would be excavated under a less robust structure called the WVDP Disposal Area Environmental Enclosure, discussed in the next section.

The conceptual NDA Environmental Enclosure would be a single-span, steel-framed building with 0.3-meter-thick (1-foot-thick) reinforced concrete exterior walls and a metal roof with gutters. The foundations would be placed outside the perimeter of known waste burials. A perimeter barrier wall and French drain are proposed to provide groundwater control during the project. These features, in addition to the burial locations, are shown on **Figure C–21**. The enclosure would be large enough to allow use of heavy equipment and erection of localized confinement structures within it. It would be well ventilated to prevent accumulation of exhaust fumes from operation of heavy equipment. The ventilation air discharge would be HEPA-filtered to limit the release of airborne radionuclides to the atmosphere and permitted to meet appropriate Federal and/or state requirements. Fire protection equipment would be included. A heating system and insulation would also be included to provide freeze protection for the fire protection system and other items inside the structure. Electrical lighting, a closed-circuit television system, and a gantry crane system would be included to support the work to be performed inside.

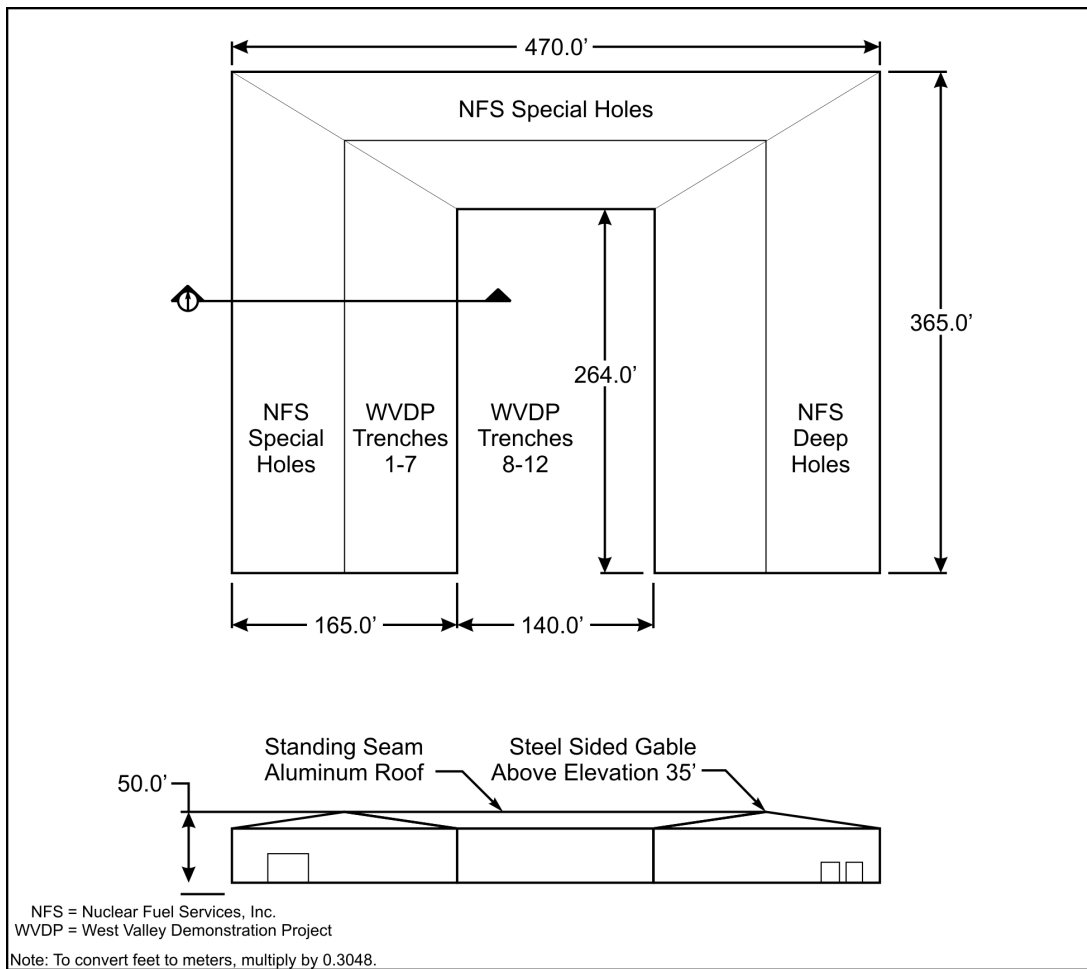

Figure C–20 Conceptual NRC-Licensed Disposal Area Environmental Enclosure – Plan and Elevation

Excavation of wastes within the NDA Environmental Enclosure would primarily be performed remotely using a combination of techniques, including Z-mast cranes, masts with various tools, and remotely operated excavators. Factors determining the excavation technique include the depth to the waste type, size of waste, and estimated activity associated with the waste. Secondary containment within the NDA Environmental Enclosure would be used for exhumation of higher-activity wastes to prevent unnecessary spread of contamination within the enclosure.

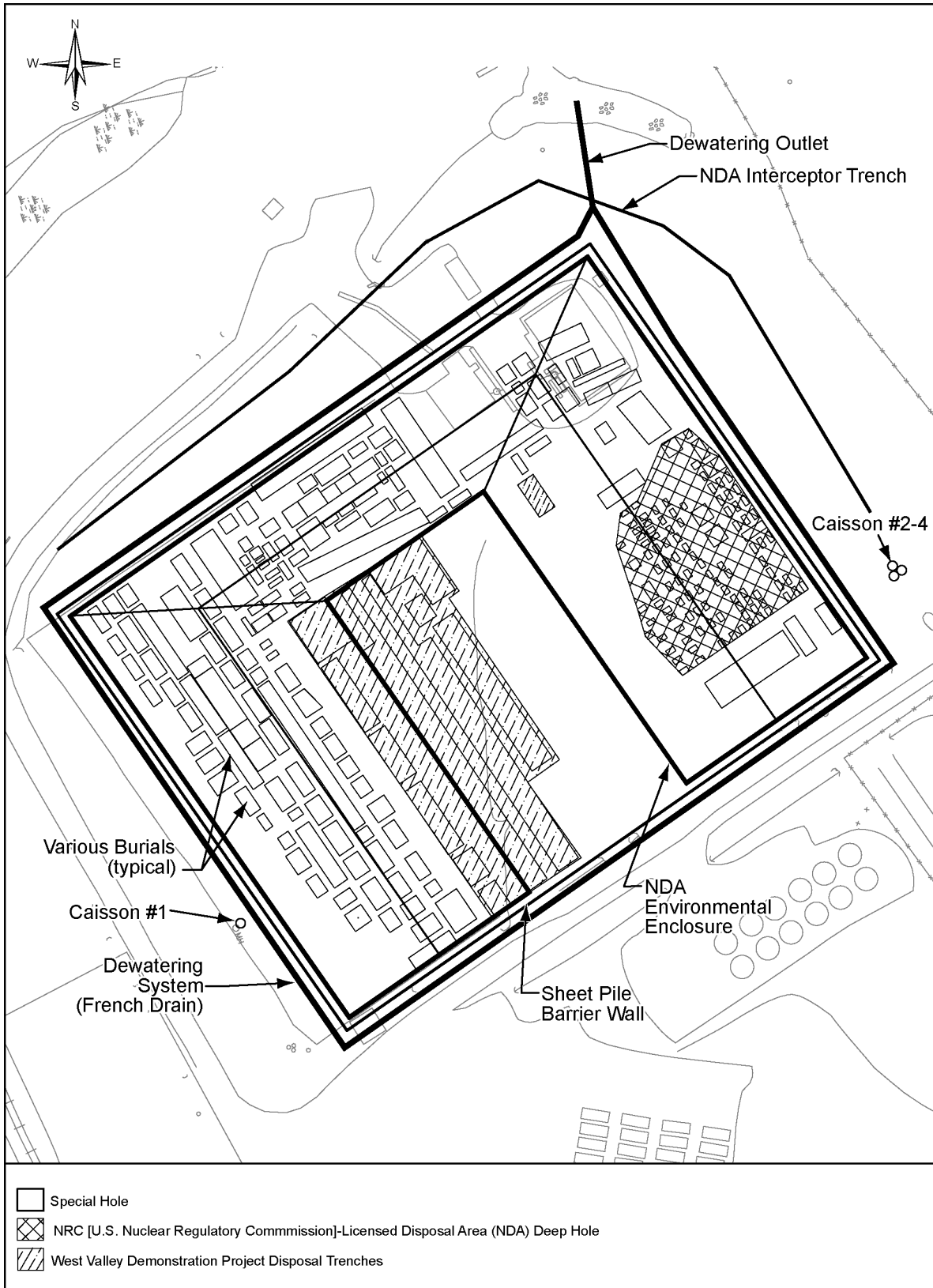

Figure C-21 Conceptual NRC-Licensed Disposal Area Barrier Wall and French Drain Layout

The HEPA filters from the ventilation system of the NDA Environmental Enclosure would be removed by bag-out procedures, wrapped in polyethylene or equivalent material, and loaded into containers as radioactive waste. The ventilation system equipment would then be selectively demolished, loaded into containers, and transferred to the Container Management Facility for characterization and shipment for offsite disposal as low-specific-activity radioactive waste.

The interior surfaces of the NDA Environmental Enclosure are expected to be slightly contaminated. Therefore, it would be thoroughly surveyed and a spray fixative applied, as necessary, to allow demolition of the structure without confinement. The enclosure would be manually demolished using conventional equipment such as hydraulic hammers and backhoes. The debris would be surveyed and sampled for characterization purposes and placed into containers for offsite disposal as a mixture of Class A low-level radioactive waste and low-specific-activity waste.

C.4.6.2 West Valley Demonstration Project Disposal Area Environmental Enclosure

A pre-engineered sheet metal confinement structure, called the WVDP Disposal Area Environmental Enclosure, would be constructed over WVDP Trenches 8 through 12, known to contain Class A low-level radioactive waste. It would be located in the “courtyard” area of the NDA Environmental Enclosure.

The conceptual WVDP Disposal Area Environmental Enclosure would be a single-span, steel-framed building with sheet metal walls and a roof with gutters. The foundations would be placed outside the perimeter of known waste burials. The structure would be about 79 meters (260 feet) by about 61 meters (200 feet), with an eave height of about 10.6 meters (35 feet), large enough to allow use of heavy equipment inside. It would be well ventilated to prevent accumulation of exhaust fumes from operation of heavy equipment. The ventilation air discharge would be HEPA-filtered to prevent migration of any airborne radionuclides to the atmosphere and permitted to meet appropriate Federal and/or state requirements. Electrical lighting would be included to support the work to be performed inside.

C.4.6.3 South State-Licensed Disposal Area Environmental Enclosure

Under the Sitewide Removal Alternative, a confinement structure, called the South SDA Environmental Enclosure, would be constructed over Trenches 8 through 14 of the SDA, which are known to contain wastes classifiable as greater than Class A low-level radioactive waste. This structure would be designed to withstand design-basis natural hazards, such as earthquakes, high winds, and snow loading (DOE 1996b). The footprint of the conceptual South SDA Environmental Enclosure is shown on **Figure C–22**.

The conceptual South SDA Environmental Enclosure would be a tri-span, steel-framed building with 0.3-meter-thick (1-foot-thick) reinforced concrete exterior walls and a metal roof with gutters. The perimeter foundations would be placed outside the perimeter of known waste burials. Pile foundations would be required to support the interior column lines. The pile foundations would be located between Trenches 9 and 10 and between Trenches 12 and 13. The piles would be driven to approximately 9 meters (30 feet) below-grade. The structure would be about 216 meters (710 feet) long by about 105 meters (345 feet) wide, with an eave height of about 10.7 meters (35 feet), large enough to allow use of heavy equipment and erection of confinement structures within it.

Similar to the NDA Environmental Enclosure, this enclosure would include a ventilation system with HEPA filtration, a fire protection system, a heating system, electrical lighting, a closed-circuit television system, and a gantry crane system.

The demolition of the South SDA Environmental Enclosure would be performed in the same manner as the demolition of the NDA Environmental Enclosure, described in Section 4.6.1.

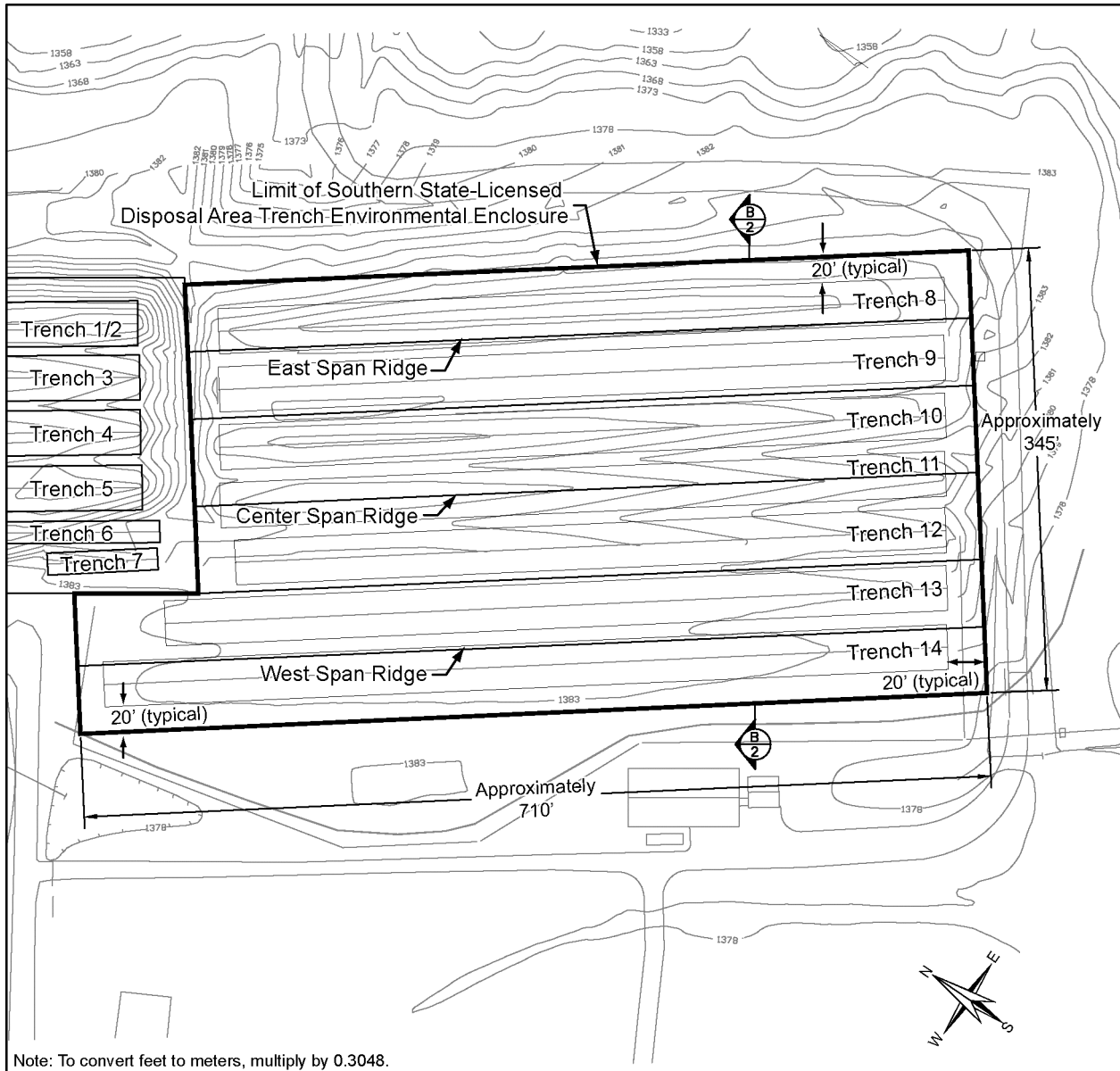

Figure C-22 Conceptual South State-Licensed Disposal Area Environmental Enclosure Footprint

C.4.6.4 North State-Licensed Disposal Area Environmental Enclosure

A confinement structure, called the North SDA Environmental Enclosure, would be constructed over Trenches 1 through 7 of the SDA, which are known to contain wastes classifiable as greater than Class A low-level radioactive waste. It would be designed to withstand design-basis natural hazards, such as earthquakes, high winds, and snow loading (DOE 1996b). The footprint of the conceptual North SDA Environmental Enclosure is shown on **Figure C-23**.

The conceptual North SDA Environmental Enclosure would be a single-span, steel-framed building with 0.3-meter-thick (1-foot-thick) reinforced concrete exterior walls and a metal roof with gutters. The foundations would be placed outside the perimeter of known waste burials. The structure would be about 232 meters (760 feet) long by about 62.5 meters (205 feet) wide, with an eave height of about 10.7 meters (35 feet), large enough to allow use of heavy equipment inside.

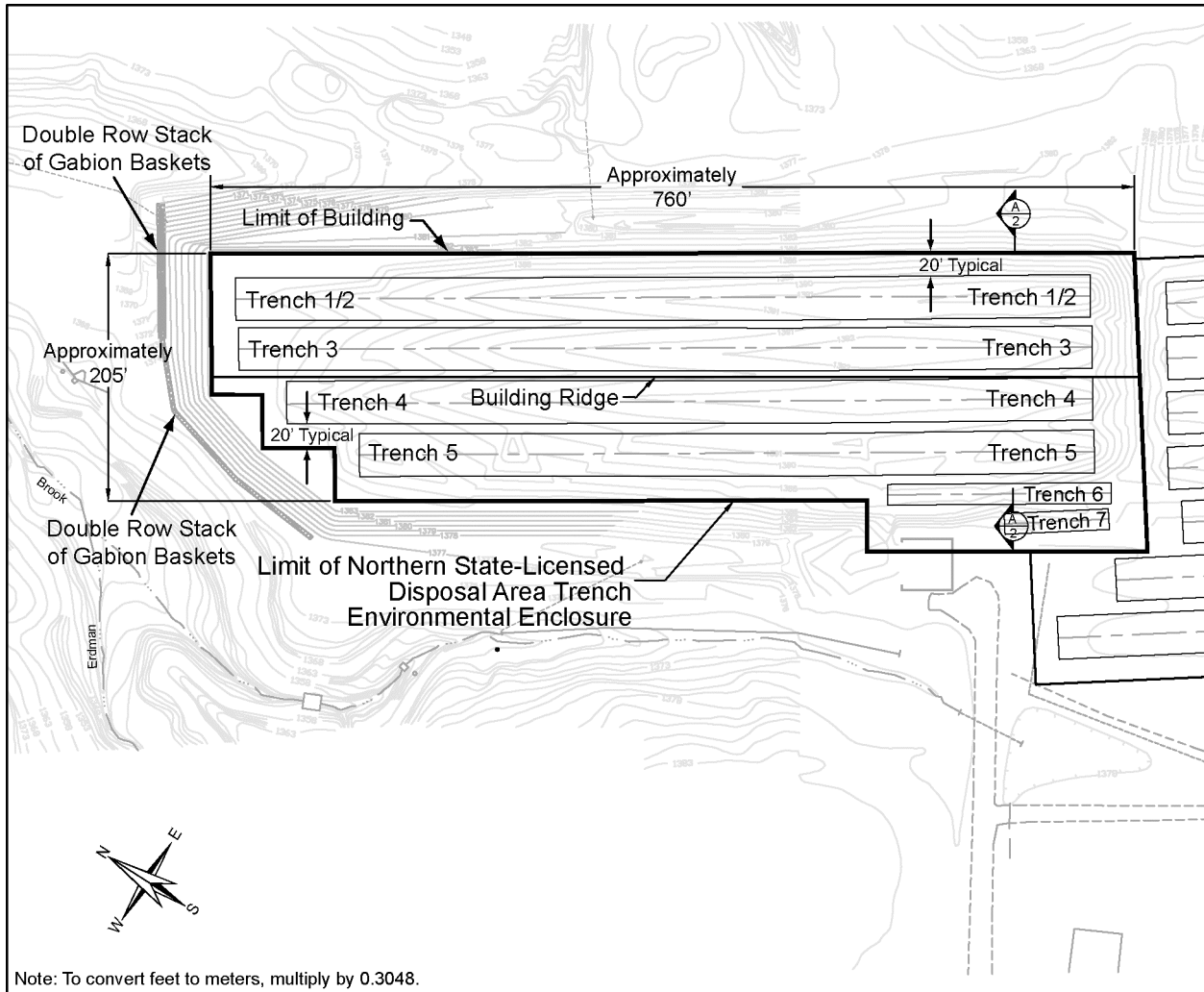

Figure C-23 Conceptual North State-Licensed Disposal Area Environmental Enclosure Footprint

Similar again to the NDA Environmental Enclosure, this enclosure would include a ventilation system with HEPA filtration, a fire protection system, a heating system, electrical lighting, a closed-circuit television system, and a gantry crane system.

The demolition of the North SDA Environmental Enclosure would be performed in the same manner as the demolition of the NDA Environmental Enclosure, described in Section 4.6.1.

C.4.6.5 State-Licensed Disposal Area Lagoon Confinement Structures

Three pre-engineered sheet metal confinement structures, called the SDA Lagoon Confinement Structures, would be constructed over each of the three filled lagoons in WMA 8. The confinement structures would be single-span, steel-framed buildings having sheet metal interior walls, concrete exterior walls, and steel roof with gutters. They would each be approximately 1,580 square meters (17,000 square feet) in size, and high enough to allow use of heavy equipment inside.

C.4.6.6 Lagoon 1 (Waste Management Area 2) Confinement Structure

A pre-engineered sheet metal confinement structure, called the Lagoon 1 Confinement Structure, would be constructed over Lagoon 1 in WMA 2 before excavation of the closed lagoon. The Confinement Structure would be a single-span, steel-framed building with sheet metal interior walls, concrete exterior walls, and a steel roof with gutters. It would be approximately 2,090 square meters (22,500 square feet) in size and high enough to allow use of heavy equipment inside.

C.4.6.7 North Plateau Groundwater Plume Source Confinement Structure

A pre-engineered sheet metal confinement structure, called the North Plateau Groundwater Plume Source Confinement Structure, would be constructed over the North Plateau Groundwater Plume source area in WMA 1, where the Main Plant Process Building previously stood. The confinement structure would be a single-span, steel-framed building with sheet metal walls and a steel roof with gutters. It would be approximately 930 square meters (10,000 square feet) in size and high enough to allow use of heavy equipment inside.

C.4.6.8 Modular Shielded Environmental Enclosure

These enclosures would be used to support exhumation of wastes from the NDA and the SDA that are expected to have characteristics that would exceed those of Class C low-level radioactive waste. The Modular Shielded Environmental Enclosures proposed for NDA and SDA remediation are considered first of their kind. There are no full-scale field examples of waste retrieval and processing operations of this magnitude and involving the waste classes that would be dealt with under the Sitewide Removal Alternative. The anticipated wastes have been listed based on historic documentation. However, there exists a significant potential to discover wastes and types that are unexpected or unplanned. The costs of construction of the facilities would be fairly reliable (within the contingency specified in the estimates), as the structural and equipment components are readily available and have been used in some capacity in the past. However, the project productivity and safety are items of uncertainty that cannot be easily estimated.

C.4.6.8.1 NRC-Licensed Disposal Area Modular Shielded Environmental Enclosure

The NDA Modular Shielded Environmental Enclosure would be designed and procured to support exhumation of wastes from the NDA that are expected to have characteristics that would exceed those of Class C low-level radioactive waste. This enclosure would control airborne emissions, shield against high-radiation fields, and permit exhumation of wastes from holes up to 16.8 meters (55 feet) deep.

The NDA Modular Shielded Environmental Enclosure would provide secondary confinement for the radiological and hazardous material releases that are expected during the excavation and retrieval activities to be performed. The enclosure would be designed to accommodate remote excavation, retrieval, and maintenance operations. It would be of modular design so that it could be customized to accommodate holes and trenches of various sizes. Individual modular panels would lock together to provide an airtight enclosure. It would be maintained under negative pressure using a HEPA-filtered ventilation system. It would be equipped with a carbon dioxide fire suppression system for conventional fires and a metal-halide fire suppression system for pyrophoric metal fires.

Because of its modular design, the NDA Modular Shielded Environmental Enclosure would enable the user to increase the overall length by adding either a roof panel or a wall panel. Several of the modules would have apparatus attached for ventilation systems, shield window atriums, and glovebox panels or equipment and waste container passages.

The wall panels of the structure would be approximately 3 meters (10 feet) wide and 6 meters (20 feet) high and would be constructed with a steel frame. A core of lead brick shielding (5 centimeters [2 inches] thick) would be installed from the bottom of the wall (ground level) to a height of 2 meters (8 feet) to provide shielding for the workers on the ground around the perimeter of the enclosure. The lead core would be held in place by steel sheeting on the inner and outer surfaces of the lead brick core. The roof panels would not be shielded.

The wall panels would fit side by side around the perimeter of the excavation (on top of the sheet pile). The roof panels would be approximately 3 meters (10 feet) wide by 3 meters (10 feet), 6 meters (20 feet), or 12 meters (40 feet) long. These different lengths would be suitable for spans of 3 meters (10 feet), 6 meters (20 feet), or 12 meters (40 feet) and could cover holes or trenches of 9 to 90 square meters (100 to 1,000 square feet), 20 to 260 square meters (200 to 2,800 square feet), or 37 to 300 square meters (400 to 3,200 square feet) in size, respectively.

The length of any of these NDA enclosure configurations could be adjusted by removing a number of wall and roof panels, the smallest configuration would be 9 square meters (100 square feet) and the largest, 300 square meters (3,200 square feet). The conceptual design included in the Sitewide Removal Alternative contains a quantity of materials sufficient to construct six structures, two of each size (span).

The NDA Modular Shielded Environmental Enclosure modules would vary in size due to hole sizes at the NDA and would employ a Z-mast crane system operating from the outside of the enclosure. The crane mast would penetrate through a boot in the top of the NDA Modular Shielded Environmental Enclosure and would perform necessary operations using remote video. This configuration was selected based on the small size of the NDA special and deep holes. It is estimated that two of these remote-operated cranes would be needed for the NDA work.

The NDA Modular Shielded Environmental Enclosure would be equipped with a soil handling workstation. This station would include a soil vacuum system that would be used to remove loose soil and collect it in appropriate containers, depending upon known characteristics of the hole or trench from which the waste was being exhumed. This station would include shielding, a shield window, master-slave manipulators, and a waste container transfer system.

The NDA Modular Shielded Environmental Enclosure would also be equipped with a material handling workstation. This station would include shielding, a shield window, a console for operating the chain hoist system, master-slave manipulators, and a waste container transfer system.

C.4.6.8.2 State-Licensed Disposal Area Modular Shielded Environmental Enclosure

The SDA Modular Shielded Environmental Enclosure would be designed and procured to support exhumation of wastes from the SDA, some of which are expected to have characteristics that would exceed those of Class C low-level radioactive waste. This enclosure would be similar in construction to the system described previously for NDA excavation.

The SDA Modular Shielded Environmental Enclosure would provide the primary confinement for the radiological and hazardous material releases that are expected during the excavation and retrieval activities to be performed. The enclosure would be designed to accommodate remote excavation, retrieval, and maintenance operations. It would be of modular design so that it could be customized to accommodate trenches of various sizes. Individual modular panels would lock together to provide an airtight enclosure. It would be maintained under negative pressure by a HEPA-filtered ventilation system. It would be equipped with a carbon dioxide fire suppression system for conventional fires and a metal-halide fire suppression system for pyrophoric metal fires.

The SDA Modular Shielded Environmental Enclosure would house a Z-mast system. The crane would be mounted on rails within the enclosure and would be able to reach to the bottom of the trenches. After lifting a load from a trench, the system would be able to move the load to the side and place it in front of an appropriate workstation. The crane system would include crane rails, side supports, an overhead bridge, a carriage, an excavating arm, and other attachments.

The SDA Modular Shielded Environmental Enclosure soil handling workstation would include shielding, a shield window, master-slave manipulators, and a waste container transfer system. The material handling workstation would include shielding, a shield window, a console for operating a chain hoist system, master-slave manipulators, and a waste container transfer system.

The roof and wall panels would be constructed similar again to the NDA panels, however the SDA roof panels would be a standard 12 meters (40 feet) in length. Because the cranes would be installed on the inside of these enclosures, the roof penetrations would not be necessary.

The SDA structures would be configured to fit the SDA trenches based on the perimeter of each trench. For example, Trench 3, with a length of approximately 210 meters (700 feet) and a width of approximately 10 meters (33 feet), would have a perimeter of almost 460 meters (1,500 feet). Based on this perimeter, a total of 76 shielded wall panels (20 feet each) and 36 roof panels (6 meters by 12 meters [20 feet by 40 feet]) would be needed. This enclosure would be approximately 220 meters (720 feet) in length and would be used for Trenches 1, 2, and 3.

A 210-meter-long (700-foot-long) enclosure would be used for Trench 4 and reused for Trench 14; a 200-meter-long (640-foot-long) enclosure for Trench 13, then 5; a 180-meter-long (600-foot-long) enclosure for Trench 8, then 9; a 180-meter-long (600-foot-long) enclosure for Trench 10, then 11; a 61-meter-long (200-foot-long) enclosure for Trench 12 only; and a 61-meter-long (200-foot-long) enclosure for Trench 6, then 7.

In summary, the Sitewide Removal Alternative concept contains a quantity of materials sufficient to construct Modular Shielded Environmental Enclosures over half (seven) of the SDA trenches and Z-mast cranes for each (seven total) of these structures. The enclosures and cranes would subsequently be used a second time to complete the remainder of the trenches.

C.4.7 Waste Management Area 1 Main Plant Process Building Excavation Downgradient Barrier Wall

To facilitate removal of WMA 1 underground structures and the contaminated soil beneath the Main Plant Process Building (i.e., North Plateau Groundwater Plume source area), a barrier wall would be installed around the footprint of the WMA 1 buildings. The wall would extend approximately 0.6 meters (2 feet) into the underlying Lavery till to isolate the subsurface structures and contamination from groundwater outside the source area. The upgradient and crossgradient portions of the barrier wall would be constructed of sheet pile, while the downgradient section would consist of a soil-cement-bentonite backfill mixture that would remain in place after remediation of WMA 1 is completed. On the upgradient side of the wall, a subsurface drain would be installed during backfilling to mitigate mounding of groundwater.

The total length of the barrier wall would be approximately 690 meters (2,250 feet), 230 meters (750 feet) of which would be soil-cement-bentonite and 460 meters (1,500 feet) of which would consist of sheet pile. The section of soil-cement bentonite wall adjacent to the excavation (approximately 150 meters [500 feet]) would be approximately 4 meters (13 feet) wide, while the remainder would be a typical three feet in width. The thicker wall with cement, adjacent to the excavation, would provide the stability necessary to accommodate

excavation up to the wall. The designed maximum hydraulic conductivity of the barrier wall would be 1×10^{-7} centimeters per second (3.9×10^{-8} inches per second).

Construction of the barrier wall would involve use of a conventional pile driver for the sheet pile section and a hydraulic excavator for the soil-cement-bentonite wall section. Approximately 5,600 cubic meters (7,300 cubic yards) of soil would be excavated for the soil-cement-bentonite wall, 5,000 cubic meters (6,500 cubic yards) of which is assumed to be contaminated and half of that volume is assumed to be saturated. The slurry and backfill mixtures for the soil-cement-bentonite wall would be prepared in contained areas, and the trench would be kept filled with slurry to support its walls during excavation. The bentonite used to support the walls of the excavation would be evaporated. Any residual material would be disposed of with the excavated soil.

C.4.8 Installation of the Waste Management Area 1 and Waste Management Area 3 Circumferential Hydraulic Barrier Walls and Multi-layer Cap

This section includes a description of the general concept for the WMA 1 and WMA 3 closure system, as well as the design features of the multi-layer cap. The last subsection presents the approach that would be used to construct the hydraulic barrier wall and the multi-layer cap.

C.4.8.1 Conceptual Design of the Closure System

A single subsurface circumferential barrier wall would be constructed around the partially demolished and stabilized facilities in WMA 1 and WMA 3. In addition to this circumferential barrier wall, a separate, chevron-shaped subsurface barrier wall would be constructed hydraulically upgradient of the circumferential barrier wall. This upgradient barrier wall would be oriented transverse to the direction of groundwater flow to divert groundwater flow and to help prevent mounding from occurring against the upgradient side of the circumferential barrier wall.

A multi-layer cover system would be constructed over the demolished and closed WMA 1 and WMA 3 facilities and the subsurface barrier walls. The top-slope portion of the multi-layer cover system would extend laterally to just beyond the top of the barrier walls, and the side-slope portions of the cover system would be located outside the limits of the barrier walls.

The actual configuration of the cover system would be based on the surrounding topography; the final height of the closed-in-place facilities; and the surface slopes required for providing adequate lateral drainage, limiting infiltration, and satisfying slope stability and erosion control requirements. The final cover configuration would be designed to preclude subsequent surface water ponding, minimize infiltration, exhibit stability under normal and stressed conditions, and protect the closure cap from excessive erosion.

The conceptual cover system and the subsurface barrier walls incorporate features that are designed to minimize degradation due to long-term exposure to environmental and geomechanical processes. Potential degradation processes include wind and/or water erosion, biological disruption by plants and animals, geochemical processes, seismic events, and inadvertent human intrusion. The cover design therefore includes redundant barrier components to help preserve long-term effectiveness. The barrier walls and low-permeability hydraulic barrier components of the multi-layer cover system are designed to meet the following objectives:

- Resist degradation due to erosional forces from wind and water, damage due to frost penetration, and potential damage by geochemical processes.
- Limit infiltration of precipitation into the stabilized structures by restricting the rate of infiltration through the closure cap and limiting the rate of lateral inflow of groundwater through the barrier wall.

- Withstand intrusion by plants, animals, and humans.
- Exhibit slope stability under static, seismic, and seepage conditions.
- Be cost-effective to construct, and require a minimum of maintenance.

A conceptual plan view drawing depicting the approximate areal extent of the multi-layer cover system is shown on **Figure C-24**.

The entire multi-layer cover system would occupy a total area of approximately 41,000 square meters (441,000 square feet), or approximately 4 hectares (10 acres). The cover would extend up to 4 to 6 meters (15 to 20 feet) above the existing ground surface. The flatter top-slope of the cover system would have a true surface area of approximately 23,000 square meters (246,000 square feet), or approximately 2.3 hectares (5.7 acres). The steeper, rip-rap-covered side-slopes would have a true surface area of approximately 18,000 square meters (195,000 square feet), or approximately 1.8 hectares (4.5 acres).

C.4.8.2 Construction of the Hydraulic Barrier Walls

The subsurface barrier walls would be constructed using the slurry trench technology. This technology was selected because it has been used extensively and successfully elsewhere and has the longest history of use of any of the barrier technologies considered for the project.

The barrier walls are designed to divert groundwater flow around the stabilized facilities. The upgradient chevron-shaped barrier wall would be a low-permeability soil-bentonite barrier wall that would reduce groundwater flow into the closed facilities area by laterally diverting groundwater flow around the circumferential wall surrounding WMA 1 and WMA 3. The circumferential barrier wall would be bimodal in its composition and hydraulic properties, consisting of two distinct portions:

- The upgradient segment of the wall would be a soil-bentonite barrier wall of similar composition and hydraulic properties as the chevron-shaped barrier wall.
- The portion of the wall downgradient of the closed facilities would be a mixture of soil, bentonite, and a sorbent material such as a granular apatite.

The soil-bentonite-sorbent material mixture incorporated into the downgradient segment of the circumferential wall would provide sorptive capability for sequestering selected radionuclides that might be dissolved in groundwater. This portion of this barrier wall would be designed to be slightly more permeable than the very-low-permeability layer of the closure cap to minimize the possibility of groundwater mounding within the circumferential wall. The downgradient segment of the wall would be constructed to achieve a hydraulic conductivity of 1.0×10^{-7} centimeters (4.0×10^{-8} inches) per second; the upgradient segment, of 1.0×10^{-8} centimeters (4.0×10^{-9} inches) per second.

The chevron-shaped and circumferential barrier walls would be constructed in the sand and gravel unit and underlying Lavery till; the base of each wall would be keyed at least 1 meter (3 feet) into the underlying unweathered Lavery till to minimize leakage of groundwater through the bottom of the walls.

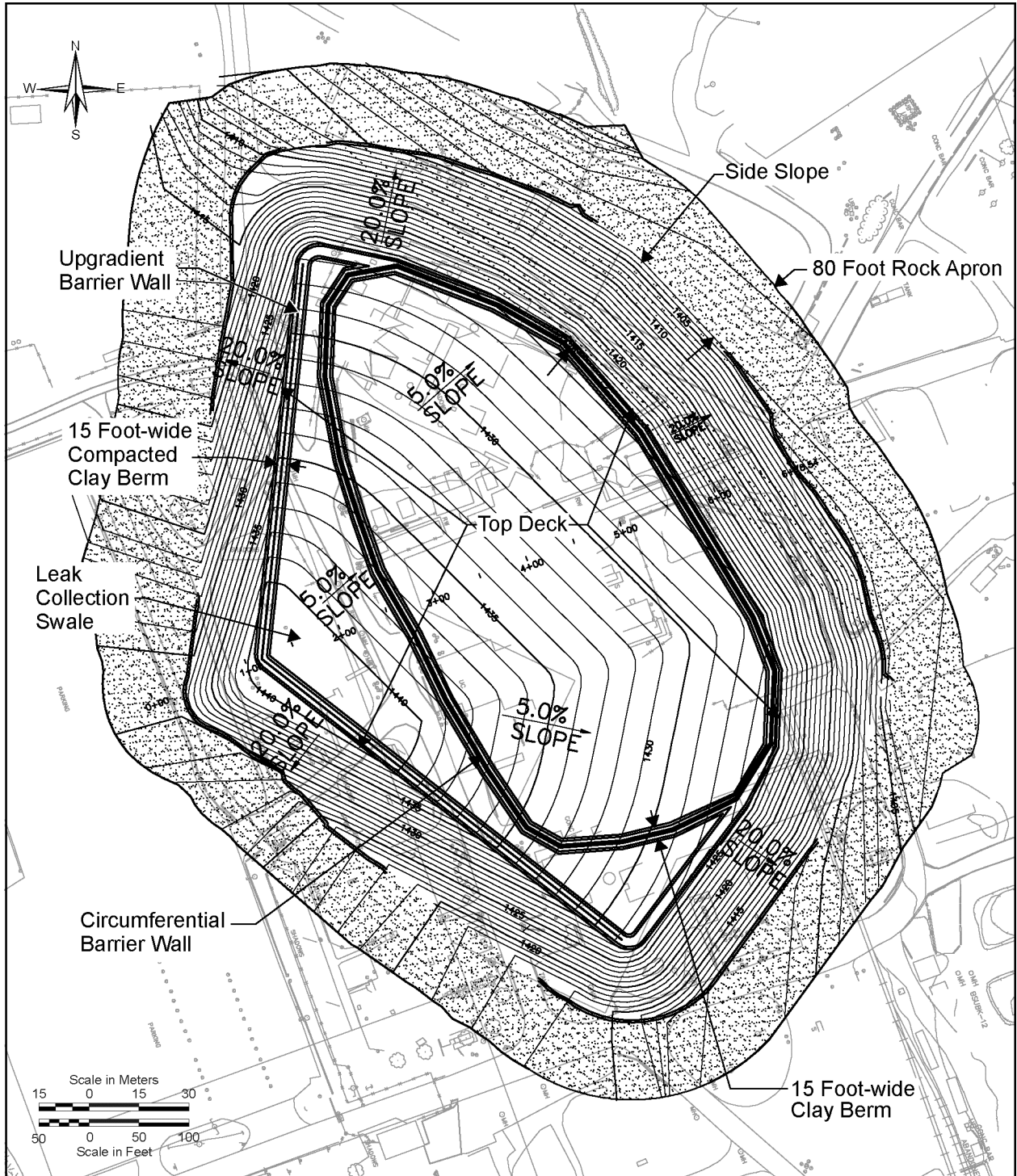

Figure C-24 North Plateau Closure Cap Conceptual Plan View

C.4.8.3 Multi-layer Closure Cap Design

The multi-layer closure cap cover system would include top-slope and side-slope portions of differing construction. Notable design features include the following:

- Thirteen separate layers in the top-slope portion, with a total thickness of approximately 3.7 meters (12.3 feet) and a 5-degree slope eastward
- Two layers in the side-slope portion, which would have a 20-percent slope, along with a 5.2-meter-wide (19-foot-wide) rock apron to provide added protection against gullying and erosion
- A perimeter barrier formed of large boulders intended to prevent access by vehicles or construction equipment

The top-slope portion of the cover would consist of the following components, from top to bottom:

- Rip-rap – 0.77 meters (2.5 feet) thick with an average stone size (D_{50}) of approximately 7.6 centimeters (3 inches) – to provide erosion protection and function as a barrier from bio-intrusion
- Rock Filter/Bedding – 0.38 meters (1.3 feet) thick with a D_{50} of approximately 3.8 centimeters (1.5 inches) – to function as bedding to rip-rap and a filter to underlying layers and to provide additional erosion protection
- Coarse Sand Filter – 15 centimeters (6 inches) thick – to serve as granular filter to prevent degradation of underlying loam layer
- Compacted Loam – 0.6 meters (2 feet) thick sandy clay soil – to provide water storage and freeze/thaw protection
- Coarse Sand Filter – 15 centimeters (6 inches) thick – to prevent clogging of underlying drainage layer
- Clean Gravel Drainage Layer – 0.3 meters (1 foot) thick with a hydraulic conductivity of approximately 0.001 centimeters per second (0.00039 inches per second) – to serve as the primary drain for removing water that percolates into the cap
- Geotextile – marginal thickness, non-woven cushion – to protect the underlying geomembrane from puncture and excessive wear from drainage gravel
- Geomembrane Liner – 60 mils (0.060 inches) of linear low- or high-density polyethylene – to serve as an infiltration barrier in the short term
- Bentonite/Additive Mixture – a 0.6 meter-thick (2 foot-thick) bentonite sand mixture with a hydraulic conductivity of approximately 5.0×10^{-9} centimeters per second (2.0×10^{-9} inches per second) – to function as a low-permeability barrier layer in the long term
- Sandy Clay Loam – a 0.3 meter-thick (1 foot-thick) compacted layer – to provide structural support for the bentonite layer and to function as secondary water storage and freeze/thaw protection
- Geocomposite – a marginal-thickness geonet with geotextile fabric to serve as a leak detection layer in the short term
- Geomembrane Liner – to function as a secondary infiltration barrier
- Compacted Clay – 0.45 meters (1.5 feet) thick with a hydraulic conductivity of approximately 7.0×10^{-7} centimeters per second (2.8×10^{-7} inches per second) – to provide foundational and structural support in addition to redundant infiltration protection

Because the side-slope portion of the closure cap would be located outside the limits of the slurry wall, it would overlie the ground located outside of the WMA 3 area. The side-slopes of the cover would be graded at approximately 20 percent, and would consist of the following components, from top to bottom:

- A rock rip-rap layer – approximately 0.6 meters (2 feet) thick with a D₅₀ size of approximately 25.4 centimeters (10 inches) – to provide erosion protection and minimize animal and human intrusion
- A granular bedding/filter layer – approximately 0.3 meters (1 foot) thick with a D₅₀ size of approximately 3.8 centimeters (1.5 inches) – to provide a uniform, competent layer for rip-rap placement and to mitigate internal soil erosion

The proposed closure cover has been evaluated for veneer (layer) stability under static, seepage, and seismic conditions. Evaluation results indicate that the proposed materials would provide the necessary sheer strength to maintain stability under static conditions with a safety factor of at least 1.5 and to survive an earthquake inducing a theoretical maximum horizontal ground acceleration equal to 0.20 g, with a safety factor of at least 1.1 (URS 2004).

The closure cover would be designed in accordance with criteria established by the NRC to protect cover systems from damage due to long-term erosion (NRC 2002) and RCRA requirements. The top-slope and side-slope portions of the cover would be sloped at approximately 5 percent and 20 percent or less, respectively. The top-slope and side slope rip-rap layers are designed to withstand the erosive effects expected from a probable maximum precipitation event at the site. The height of the cap would be approximately 5 to 6 meters (15 to 20 feet) above the existing grade.

C.4.8.4 Performance of Permeable Treatment Walls, Hydraulic Barrier Walls, and Covers

Engineered hydraulic barriers and covers are described in various locations throughout Sections C.3.2 and C.3.3 for the Sitewide Close-In-Place and Phased Decisionmaking Alternatives, respectively, as well as previously in this section. Performance of the permeable treatment wall would be predicated on how effective the zeolite material is on contaminant removal and how long it lasts. To reduce uncertainties associated with the performance of the permeable treatment wall, a study was conducted that evaluated the performance of the pilot-scale permeable treatment wall (WVNSCO 2002). While the study showed where constructional and operational improvements could be made in a full-scale system, other factors could influence the performance of the technology. These include both hydraulic factors, such as groundwater bypass around the system and dispersal of “treated” groundwater, and operational factors, such as the logistics and practicality of replacing the zeolite approximately every 20 years.

There is uncertainty about the long-term performance of other engineered barriers, including multi-layered covers, waste grout, and barrier walls. Hydraulic factors, such as mounding and groundwater bypass, and other aspects, such as long-term durability, could potentially impact the long-term performance of barrier walls designed to keep subsurface contaminants from migrating off the site. Long-term performance of closure caps could be affected by erosion and differential settlement that increases the permeability of the engineered covers. These hydraulic factors are mitigated in the analysis by use of conservative assumptions. The performance of the hydraulic barriers is incorporated into the sensitivity analysis presented in Appendix H of this EIS.

C.4.9 Waste Management Area 2 Lagoons Engineered Multi-layer Cover

An engineered multi-layer cover would be installed over Lagoons 1 through 5 in WMA 2 as part of the Sitewide Close-In-Place Alternative. The cover would consist of the following layers:

Sand and Gravel Backfill: Backfill would be placed in all of the lagoons to fill them to the surrounding ground surface. The sand and gravel backfill would be filled using a bulldozer. As the lagoons are being filled, the backfill would be watered and compacted by a sheepsfoot roller.

Compacted Clay Layer: A minimum of a 1-meter-thick (3-foot-thick) clay liner would be spread over the entire proposed multi-layer cap by a bulldozer (see **Figure C-25**). As the liner is being spread, water would be applied, and the laid liner would be compacted with a sheepsfoot roller. The liner would also be tested to ensure it meets the required placement specifications.

Geosynthetic Liner: A 60-mils (0.060-inch) low-density polyethylene membrane would be installed over the entire compacted clay layer.

Drainage Layer: A 0.6-meter-thick (2-foot-thick) drainage layer would be installed over the geosynthetic liner. The drainage layer would consist of screened and clean, washed gravel. This layer would be placed by a bulldozer and compacted by a sheepsfoot roller.

Intruder Barrier: A 1-meter-thick (3-foot-thick) intruder barrier would be installed over the drainage layer. This barrier would consist of cobbles and would be placed over the drainage layer by a front-end loader.

Vegetation Layer: A 46-centimeter (18-inch) layer of topsoil would be placed on top of the entire landfill cover. Seed and mulch would be applied over the topsoil to provide erosion protection.

C.4.10 Barrier Wall in Waste Management Area 2

To facilitate the long-term performance of the remedial work at WMA 2 under the Phased Decisionmaking Alternative, a subsurface soil-cement-bentonite barrier wall would be installed. The assumed location of the barrier is shown on Figure C-25. The wall would extend approximately 0.6 meters (2 feet) into the underlying Lavery till to create a vertical hydraulic barrier, reducing the likelihood of the North Plateau Groundwater Plume cross-contaminating the backfilled lagoons. The barrier wall would consist of a soil-cement-bentonite backfill mixture that would remain in place after remediation of WMA 2 is completed. The designed maximum hydraulic conductivity of the barrier wall would be 1×10^{-7} centimeters per second (4×10^{-8} inches per second). Construction of this wall would be similar to the process described in Section C.4.7 for WMA 1.

The soil-cement-bentonite barrier wall would be approximately 320 meters (1,050 feet) in length and approximately 4 meters (13 feet) in width to permit the nearby excavation to occur up to the base of the wall.

Liquid bentonite slurry would be prepared using a shear mixer and would be contained in earthen containment berms until such time that it is needed for trench construction. During the excavation process, the trench would be kept filled with bentonite slurry to provide the necessary stability of the trench walls.

The soil-cement-bentonite backfill material would be mixed using heavy equipment (excavator, bulldozer, or loader) on a concrete mixing pad. During the mixing process, the dry ingredients and dry bentonite would be mixed together, and then the hydrated bentonite slurry would be pumped in and mixed to create a thick mud-like consistency. Prepared backfill material would then be loaded into dump trucks or moved directly to the trench site using loaders or cranes and finally would be placed in the trench. The backfill would displace the slurry, which would then be used to continue the trench excavation.

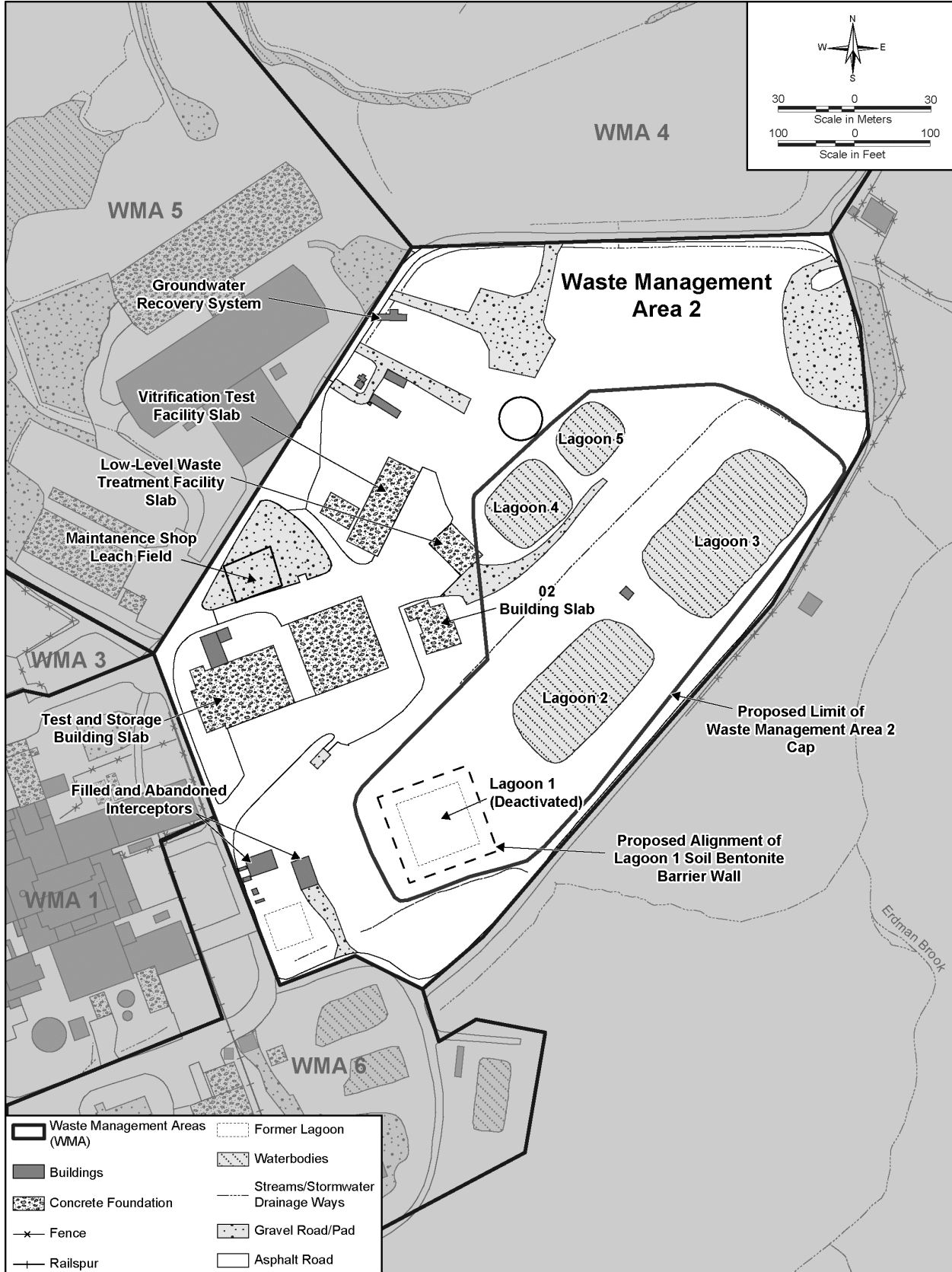

Figure C-25 Plan View of Cap and Barrier Wall in Waste Management Area 2

C.4.11 NRC-Licensed Disposal Area and State-Licensed Disposal Area Engineered Multi-layer Covers

Engineered multi-layer covers would be used to replace the geomembranes and isolate buried wastes at the NDA and SDA under the Sitewide Close-In-Place Alternative.

The conceptual design and construction methodology of the engineered multi-layer covers over the NDA and SDA are the same as those described for the engineered multi-layer cover proposed for the isolation of WMA 1 and WMA 3, described in Section C.4.8. However, due to the limited groundwater flow in the South Plateau, it was determined that downgradient barrier walls would serve no purpose. For this reason, the barriers designed for the South Plateau disposal areas would be constructed on the upgradient side of the NDA and SDA.

The NDA cover's footprint would be approximately 4 hectares (10 acres).

The SDA cover's footprint would be approximately 11 hectares (28 acres).

C.4.12 Circumferential Barrier Wall in Waste Management Area 2

Under the Sitewide Close-In-Place Alternative, a subsurface soil-bentonite barrier wall would be used to divert groundwater around the portion of Lagoon 1 that is below the groundwater table. The wall would extend around the perimeter of the lagoon. In-place soil mixing would be used to help stabilize and encapsulate the remaining contaminated sediments, soils, and debris in Lagoon 1. The barrier wall would be keyed approximately 0.9 meters (3 feet) into the underlying till and would extend vertically at least above the seasonal high groundwater table elevation in that area.

C.4.13 Erosion Control Structures

Under the Sitewide Close-In-Place Alternative, long-term erosion without mitigation may negatively impact several WMAs. Successful in-place closure and long-term management of these WMAs would therefore depend on methods to control erosion over time.

The strategy for controlling erosion would include use of the following measures:

- Diversion berms and ditches
- Water control structures
- Streambed armoring

The location of these features and the general conceptual design for long-term erosion control are shown on **Figure C-26**. The primary objectives of these measures would be to control surface water runoff to mitigate gully erosion progress and to reduce streambed erosion. The conceptual design provides an integrated approach to controlling erosion on both the North Plateau and the South Plateau, especially around the closed in-place facilities.

Erosion controls would be designed to accommodate the probable maximum flood consistent with guidance in NUREG-1623, *Design of Erosion Protection for Long-Term Stabilization* (NRC 2002). Designs would be intended to function without long-term maintenance, although it is assumed that periodic inspections and maintenance would be performed. The strategy for controlling erosion at the site would be implemented in three general terrain areas: flat-sloped plateaus where unconcentrated sheet flow occurs; steeper-sloped areas where sheet flow becomes concentrated; and streambed areas where concentrated flows are fully developed.

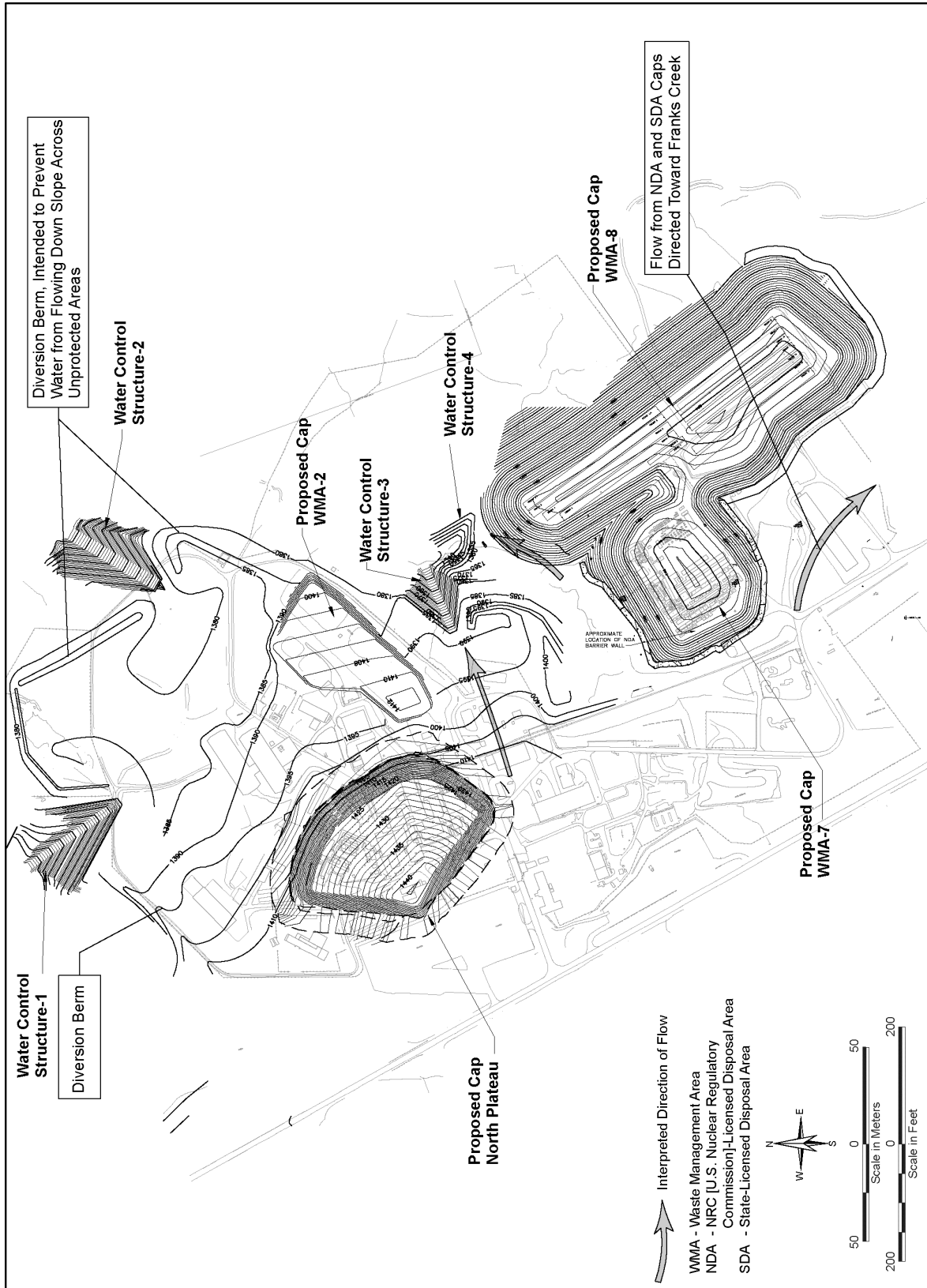

Figure C-26 Location and Conceptual Design for Long-term Erosion Control

Conventional construction methods would be used; bulldozers and excavators would remove soil for installation of the erosion control structures. Some of the removed soil would be used as fill to establish the preliminary grade for the closure cap installations.

Diversion Berms and Ditches

Diversion berms and ditches would be provided on the North Plateau to direct stormwater and sheet flow to water control structures located at strategic points, thereby preventing runoff from flowing down unprotected slopes and deepening existing gullies or cutting new ones. The diversions would consist of trapezoidal-shaped channels with a supporting ridge on the lower side, as shown on **Figure C-27**. The tops of the ridges would be approximately 3–6 meters (10–20 feet) wide, as shown on the figure.

To minimize long-term erosion of the berms and ditches themselves, they would be armored with three layers of aggregate. Coarse sand at the base would serve as a filter layer to create stability between the base soil and the bedding layer. The sand would be covered with a layer of rock bedding, which would be topped with a layer of rip-rap.

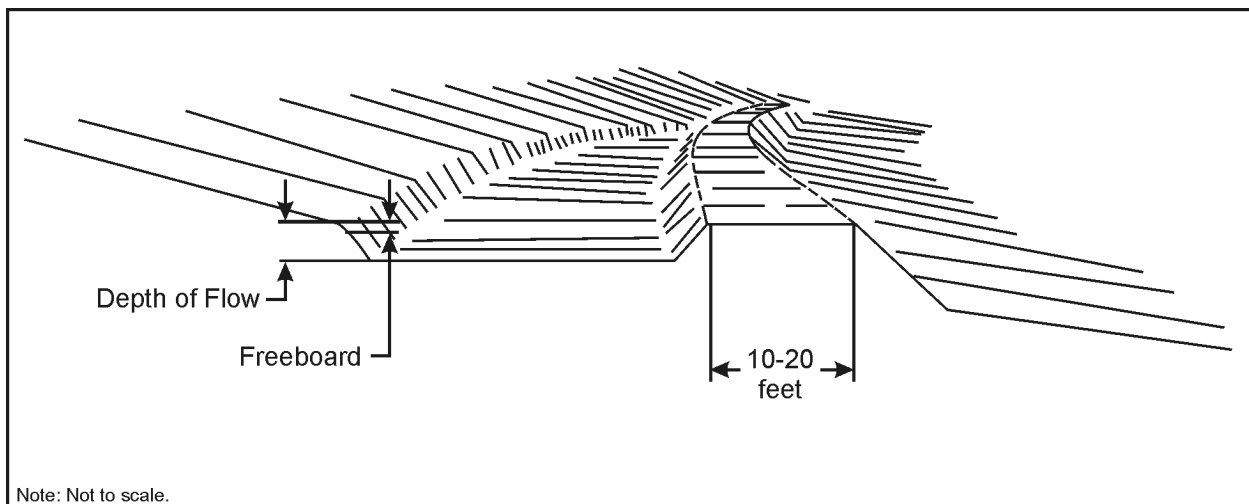

Figure C-27 Typical Diversion Berm

Water Control Structures

Water control structures would be provided at the locations shown on Figure C-26. The construction of each structure would be similar to that shown on **Figure C-28**.

These water control structures would channel flow from the plateau surface down to the creek bottom in a manner that would dissipate energy and minimize erosive impacts, being designed so that surface water runoff from events up to the 100-year rainfall would pass through concrete piping instead of running down the slope. Concrete fill would be poured around the piping to promote long-term durability.

A broad-crested weir and an armored overflow spillway would be provided to accommodate the probable maximum flood. Both the spillway and pipe discharges would be protected using discharge aprons. These structures would be reinforced with rip-rap/rock armoring.

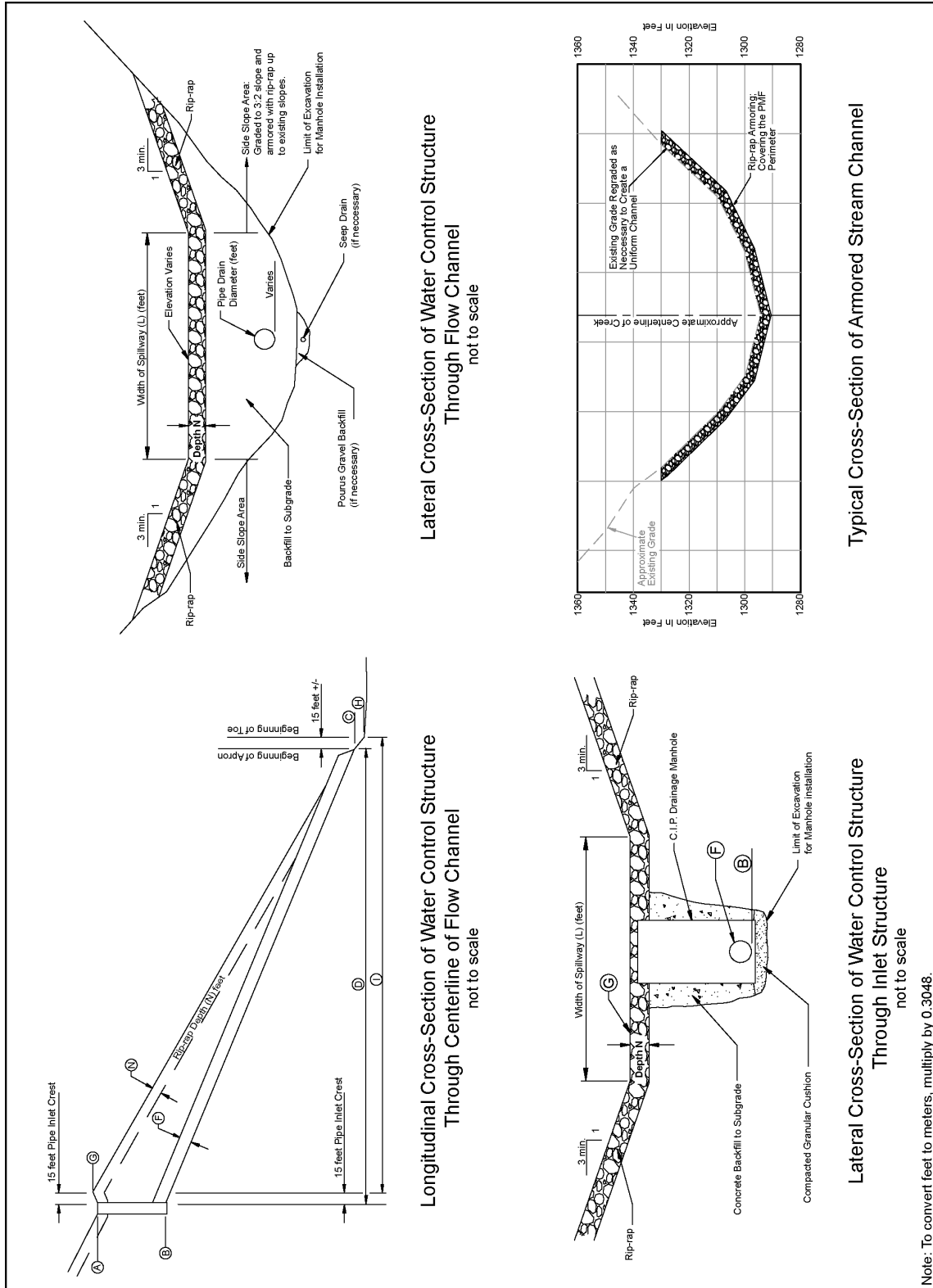

Figure C-28 Typical Water Control Structure

Streambed Armoring

Stone armoring would be installed in the beds of Quarry Creek, Erdman Brook, and Franks Creek from upstream of the SDA to its confluence with Buttermilk Creek to provide protection against the erosive forces of water flowing downstream. This armoring would ensure that erosive forces do not continue to lower the streambed elevation. Figure C-28 illustrates the typical cross-section of an armored stream channel.

The total armored length of these streams would be approximately 3,970 meters (12,900 feet).

Planning for excavation of streambed material for installation of the rip-rap armor would take into account the results of the streambed characterization surveys. Excavation necessary to install the rip-rap armor would include removal of contaminated streambed sediment along with other uncontaminated material.

The process to be used for each stream would begin with clearing trees and undergrowth from both sides of the stream and establishing temporary haul roads. Although construction would be purposely planned during dry months, a bypass pumping system would be placed in operation to remove the baseline stream flow. Construction would likely proceed from Buttermilk Creek, in an upstream direction, with relatively short sections of stream being reconstructed at a time. Bypass pumping would move upstream with construction, pumping only that necessary for construction. Excavation would be accomplished using conventional equipment such as excavators and bulldozers to provide uniform streambed geometry and slope. The streambed may be straightened in some cases as the new bed is shaped.

After flow diversion, clearing, and excavation, a filter layer consisting of coarse sand would be laid in the excavated streambed. A layer of rock bedding would be laid on top of the sand. Then a layer of rip-rap would be placed over the rock bedding to form a dense, well-graded mass of stone with minimum voids. Finally, the streamflow would be redirected back to the armored streambed.

C.5 References

DOE (U.S. Department of Energy), 1996a, *Draft Environmental Impact Statement for Completion of the West Valley Demonstration Project and Closure or Long-Term Management of Facilities at the Western New York Nuclear Service Center*, DOE/EIS-0226-D, West Valley Area Office, West Valley, New York, January.

DOE (U.S. Department of Energy), 1996b, *Natural Phenomena Hazards Performance Categorization Guidelines for Structures, Systems, and Components*, DOE-STD-1021-93, Change 1, January.

Ecology and Environment Inc., 1994, *RCRA Facility Investigation for NYSERDA-Maintained Portions of the Western New York Nuclear Service Center*, Final Report, NY7914_D4398, Lancaster, New York, December.

Geomatrix (Geomatrix Consultants, Inc.), 2007, *Focused Analysis of Remediation Alternatives for Groundwater Plume Expansion and Seepage to Surface Water, West Valley Demonstration Project – North Plateau Strontium-90 Plume*, Project No. 13302, West Valley, New York, May 30.

Landau, B., A. Russillo, D. Frank, and D. Garland, 1989, *The Design, Construction, and Operation of the Integrated Radwaste Treatment System (IRTS), Drum Cell*, Topical Report, DOE/NE/44139-52, West Valley Nuclear Services Co. Inc., West Valley, New York, December.

NRC (U.S. Nuclear Regulatory Commission), 2002, *Design of Erosion Protection for Long-Term Stabilization - Final Report*, NUREG-1623, September.

PG&E (Pacific Gas and Electric Company), 2002, *Diablo Canyon Independent Spent Fuel Storage Installation Safety Analysis Report*, October.

Prudic, D. E., 1986, *Groundwater Hydrology and Subsurface Migration of Radionuclides at a Commercial Radioactive Waste Burial Site, West Valley, Cattaraugus County, New York*, U.S. Geologic Survey Professional Paper 1325.

SAIC (Science Applications International Corporation), 2005a, *U.S. Nuclear Regulatory Commission-Licensed Disposal Area (NDA) Hazardous Material Inventory Estimate*, Germantown, Maryland, September.

SAIC (Science Applications International Corporation), 2005b, *State-Licensed Disposal Area (SDA) Hazardous Material Inventory Estimate*, Germantown, Maryland, September.

URS (URS Corporation), 2000, *Estimated Radionuclide Inventory for the NRC-Licensed Disposal Area at the West Valley Demonstration Project, Volume 1 Main Report*, Orchard Park, New York, August.

URS (URS Corporation), 2002, *SDA Radiological Characterization Report*, Orchard Park, New York, September 20.

URS (URS Corporation), 2004, *Evaluation of Multi-layer Cover Veneer Stability for the North Plateau (WMA 1 & 3) Alternative 3 Cover Design (08/2004)*, Calculation BUF-2004-324, Rev. 0, Orchard Park, New York, August 12.

URS (URS Corporation), 2005, *Hazardous Chemical Inventory Estimate for the Waste Tank Farm*, WSMS-OPS-05-0008, Rev. 2, Orchard Park, New York, August 16.

URS (URS Group, Inc.), 2008a, Letter from E. D. Picazo, URS Group, Inc., to R. E. Steiner, II, West Valley Environmental Services, LLC, Subject: *Transmittal of Estimated Demolition Ready Residual Hazardous Materials Inventory of the Main Plant Process Building (MPPB) at the West Valley Demonstration Project*, April 23.

URS (URS Group, Inc.), 2008b, Letter from E. D. Picazo, URS Group, Inc., to R. E. Steiner, II, West Valley Environmental Services, LLC, Subject: *Transmittal of Estimated Demolition Ready Residual Hazardous Materials Inventory of the Vitrification Facility (VF) at the West Valley Demonstration Project*, April 23.

Westcott, D. R., 1998, West Valley Nuclear Services Company, Inc., Personal communication (email), Expanded Source Term for the North Plateau Groundwater Plume, January 15.

WSMS (Washington Safety Management Solutions), 2009a, *Sitewide Removal Alternative Technical Report*, WSMS-WV-08-0002, West Valley, New York, December.

WSMS (Washington Safety Management Solutions), 2009b, *Sitewide Close-In-Place Alternative Technical Report*, WSMS-WV-08-0004, West Valley, New York, December.

WSMS (Washington Safety Management Solutions), 2009c, *Phased Decisionmaking Alternative Technical Report*, WSMS-WV-08-0005, West Valley, New York, December.

WSMS (Washington Safety Management Solutions), 2009d, *No Action Alternative Technical Report*, WSMS-WV-08-0003, West Valley, New York, December.

WSMS (Washington Safety Management Solutions), 2009e, *Facility Description and Methodology Technical Report*, WSMS-WV-08-0001, West Valley, New York, December.

WVES (West Valley Environmental Services, LLC), 2007, *Annual Summary Report for the North Plateau Strontium-90 Groundwater Plume, October 1, 2006 to September 30, 2007*, December 31.

WVES (West Valley Environmental Services, LLC), 2008a, Correspondence from D. H. Kurasch (WVES) to D. Westcott (WSMS), Subject: *Transmittal of Estimated Demolition Ready Radiological Inventory of the Main Plant Process Building (MPPB) at the West Valley Demonstration Project*, January 3.

WVES (West Valley Environmental Services, LLC), 2008b, Correspondence from D. H. Kurasch (WVES) to D. Westcott (WSMS), Subject: *Estimated Demolition-Ready Radiological Inventory of the Vitrification Facility (VF) at the West Valley Demonstration Project*, January 7.

WVES (West Valley Environmental Services, LLC), 2008c, Correspondence from D. C. Meess (WVES) to D. Westcott (WSMS), Subject: *Transmittal of Estimated Radiological and RCRA Hazardous Inventory in Tanks 8D-3 and 8D-4*, January 8.

WVES (West Valley Environmental Services, LLC), 2008d, Correspondence from D. C. Meess (WVES) to D. Westcott (WSMS), Subject: *Transmittal of Estimated RCRA Hazardous Inventory in Tank 8D-4*, January 16.

WVES and URS (West Valley Environmental Services LLC and URS - Washington Division), 2008, *West Valley Demonstration Project Annual Site Environmental Report for Calendar Year 2007*, West Valley, New York, December.

WVNS (West Valley Nuclear Services Company, Inc.), 1993, *West Valley Demonstration Project, Environmental Information Document, Vol. VI, Site Radiological Surveys*, WVDP-EIS-007, Rev. 0, February.

WVNS (West Valley Nuclear Services Company, Inc.), 1995, *Low-Level Waste Treatment Facility Waste Characterization Report*, West Valley Demonstration Project, WVDP-EIS-019, Rev. 1, West Valley, New York, May.

WVNSCO (West Valley Nuclear Services Company), 1997, *Resource Conservation and Recovery Act Facility Investigation Report, Volume 4: Low-level Waste Treatment Facility*, West Valley Demonstration Project, West Valley, New York, WVDP-RFI-021, Revision 0, West Valley, New York, January 17.

WVNSCO (West Valley Nuclear Services Company, Inc.), 2002, *Supplemental Hydrogeologic Investigation of the North Plateau Pilot Permeable Treatment Wall: Performance Assessment and Evaluation of Potential Enhancements*, November.

WVNSCO (West Valley Nuclear Services Company, Inc.), 2004, *West Valley Demonstration Project 6, NYCRR Part 373-2, Hazardous Waste Permit Application*, WVDP-443, Rev. 0, December.

WVNSCO (West Valley Nuclear Services Company, Inc.), 2005, *West Valley Demonstration Project, Residual Radionuclide Inventory Estimate for the Waste Tank Farm*, Supplemental Report, West Valley Nuclear Services Company and Gemini Consulting Company, February 7.