

APPENDIX G
MODELS FOR LONG-TERM PERFORMANCE ASSESSMENT

APPENDIX G

MODELS FOR LONG-TERM PERFORMANCE ASSESSMENT

Appendix D presented the conceptual approach to long-term performance assessment, discussed the need for site-specific models, and identified site-specific receptors and exposure scenarios. This appendix presents descriptions of the mathematical models used to estimate human health impacts due to releases of radionuclides and hazardous chemicals from facilities located on the West Valley Site over a long term. Facilities include the Main Plant Process Building, the Vitrification Facility, the Low-Level Waste Treatment Facility, the Waste Tank Farm, the New York State-licensed disposal area (SDA), and the U.S. Nuclear Regulatory Commission (NRC)-licensed disposal area (NDA). Section G.1 summarizes the technical approach to long-term performance assessment discussed in detail in Appendix D and the approach to development of mathematical models. Sections G.2, G.3, G.4, and G.5 describe models used for assessment of scenarios involving residual contamination of surface soil, release to groundwater, direct intrusion into residual contamination, and release to surface water due to erosion, respectively. Locations and activities of receptors and a summary of values of parameters used in the analysis are presented in Section H.1.2 of Appendix H. Results of analysis of base and sensitivity cases are also presented in Appendix H.

G.1 Approach for Development of Mathematical Models

Estimation of long-term impacts is based on analysis of scenarios defined as combinations of site environmental conditions, inventories of hazardous constituents, facility designs, environmental transport pathways, and receptor location and behavior patterns that result in exposure of an individual to hazardous material. Analysis of these scenarios involves use of deterministic models and deterministic sensitivity analysis. The mathematical models are used within the iterative design and analysis procedure represented in **Figure G-1**. Review criteria that may be used at some point in the iterative procedure include dose limits specified by the U.S. Department of Energy (DOE), NRC and New York State, correspondence to the Comprehensive Environmental Response, Compensation, and Liability Act (CERCLA) risk range and Resource Conservation and Recovery Act (RCRA) facility closure requirements. A more detailed discussion of the potential requirements is presented in Chapter 5. The result of application of this procedure, described in detail in Appendix D, is a set of site-specific scenarios comprising four general types. The first type of scenario involves contact of an individual with surface soil having residual contamination. The second type of scenario involves release from a disposal facility to groundwater, transport through an aquifer to a well or surface water and exposure of an agricultural resident to contamination in soil, groundwater, surface water or fish. The third type of scenario involves contact of an intruder with contamination in soil or buried residual contamination. The fourth type of scenario involves erosion collapse of a facility into surface water resulting in exposure of a downstream agricultural resident to contamination in soil, surface water or fish.

For scenarios involving contact with residual contamination in surface soil, impacts were estimated using the RESRAD computer code (Yu et al. 1993) for radionuclides and using algebraic equations recommended by federal guidance (EPA 1996, 1999, 2000) for chemical constituents. For groundwater release, intrusion, and erosion scenarios the approach developed for this analysis was use of site-specific models comprising release, groundwater transport, and human health impact modules. For groundwater release scenarios, the direction and rate of movement of water around and through the residual contamination was estimated using the near-field flow models described in Appendix E. Results from the near-field flow analysis serve as input data for the release modules of the groundwater release scenario impact models. The balance of this section summarizes the approach followed for development of mathematical models.

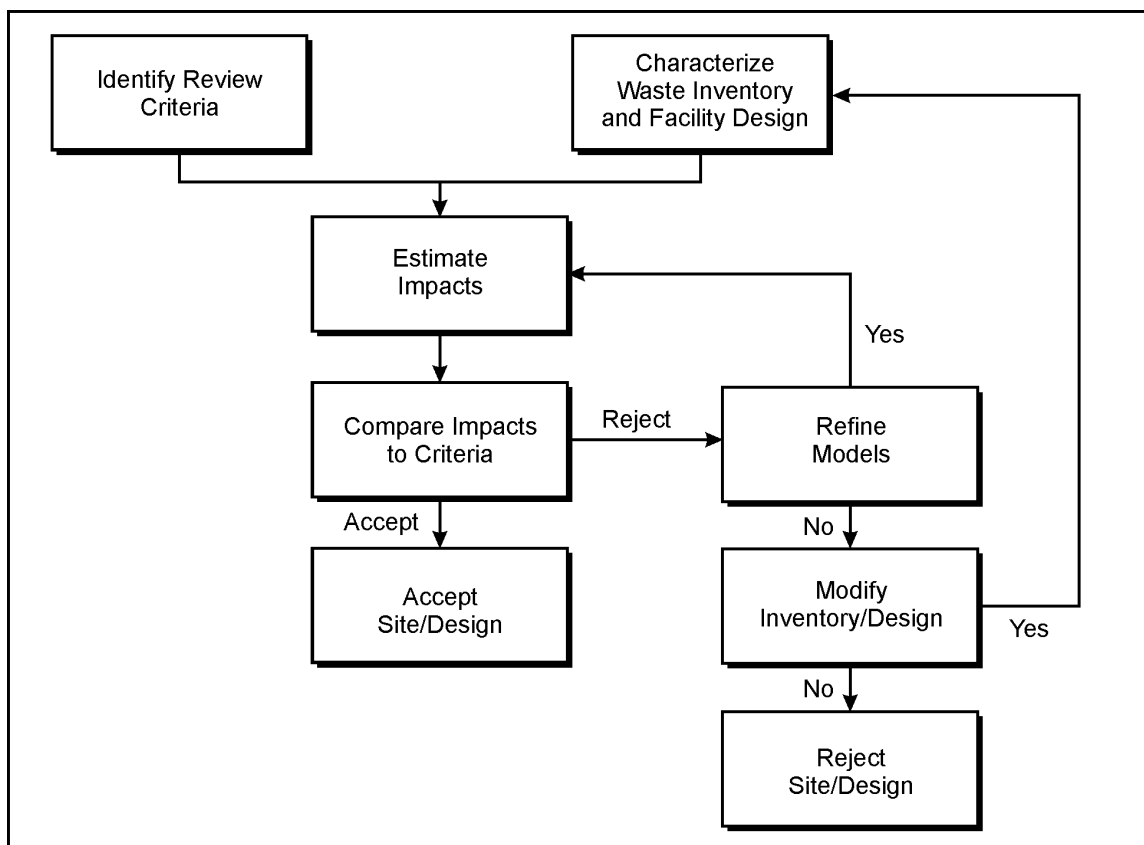

Figure G-1 Schematic of the Design, Analysis, and Evaluation Process

The procedure for development of site-specific models, involving formulation of conceptual and mathematical representations of physical processes, computerized solving of descriptive equations, and use of the computer models, is summarized in the eight steps listed in **Table G-1**.

Table G-1 Steps in Development of Mathematical Models

<i>Step Number</i>	<i>Content</i>
1	Characterize physical processes.
2	Develop conceptual model of the physical processes.
3	Develop physical mechanism-based mathematical description of the conceptual model.
4	Develop algorithm for solution of equations.
5	Develop computer code implementing solution algorithm.
6	Verify computer code.
7	Document model concepts, mathematical representations, computer code verification and utilization procedures.
8	Apply model for system analysis.

In the initial two steps of the procedure, descriptions of site physical processes (geologic, hydrologic, meteorological, etc.) are reviewed, important elements are identified and a simplified representation amenable to mathematical description is developed. For example, the results of site geophysical and hydrologic monitoring programs were reviewed and the complex spatial distribution of soil types and geohydrologic structures were condensed into a simplified geometrical representation comprising a limited number of distinct layers and deposits each having relatively uniform properties. Details of this element of the analysis are

presented in Appendix E. In the third step of the procedure, material and momentum balances were used to describe the magnitudes and rates of movement of water and hazardous constituents through the engineered barriers and the environment. This step involved description of the role of physical processes contributing to movement of water and contaminants through the barriers and environment, identification of simplifying assumptions, and formulation of the balances for appropriate elementary volumes. For example, in the case of groundwater transport through the environment advection, dispersion, retardation, and decay were selected as important physical processes; one-dimensional flow and spatially uniform physical properties were assumed and the mass balance for a constituent was formulated as an ordinary differential equation with concentration as the dependent variable and time and position as the independent variables. The fourth step in the procedure involved identification of the sequence of steps followed in solving the descriptive equations. Generally, this involved use of analytic solutions to the equations, repetitively applied to differing hazardous constituents, times, and positions. The fifth step in the procedure involved development of computer codes to implement the solution algorithms developed in the preceding step. Code development and maintenance procedures were consistent with standard practice (NRC 1993). The final three steps of the procedure involved verification, documentation, and application. A summary of model development is presented in this appendix and documentation of results of application of the models are presented in Appendix H.

Verification of computer codes involved the five steps summarized in **Table G–2**. Review of the model concept involved checking the system schematic, identification of the nature and role of physical processes, and formal listing of assumptions. Review of development of mathematical relations involved identification of model functions; checking of the basic mass, momentum, and energy balances, supporting correlations, and algorithms; and construction of lists of model parameters and dependent and independent variables. Review of computer implementation of equations and algorithms involved cross-checking of consistency of the programmed equations and algorithms, checking of computer code syntax, and checking for consistency with the rules and procedures of the computer code compiler. The fourth step in the verification procedure involved development and execution of test cases and comparison of results of model calculations with results developed using alternate models and hand calculations. Results of prior steps of the verification process supported selection of the test cases. In the fifth step, results of the first five steps were documented in a verification package. The final step of the verification package was review of the verification package by an independent, qualified analyst.

Table G–2 Verification Procedure for Computer Models

<i>Step Number</i>	<i>Content</i>
1	Review model concept.
2	Review development of mathematical relations and algorithms.
3	Review computer code implementation of equations and algorithms.
4	Develop acceptance criteria and test cases and compare predictions of the subject model, alternate models and hand calculations.
5	Document the verification.
6	Provide independent review of the verification.

The verification procedure described above was applied to the integrated codes developed for the groundwater release, intruder, and erosion collapse scenarios. Because the release and groundwater transport elements of the intruder and erosion collapse integrated codes are not complex, verification of these codes was performed in a single step as represented in Table G–2. Because the groundwater release scenario integrated codes involve more complex release and groundwater transport modules, these codes were verified in a process involving repeated application of the process represented in Table G–2. First, stand-alone versions of the release, groundwater transport, and exposure modules were developed and individually verified. Second, the individual modules were combined into integrated codes that were then verified.

G.2 Residual Contamination of Surface Soil

Following removal of waste or decontamination of site facilities low levels of residual contamination could remain in onsite soil. The residual contamination could comprise radioactive or chemical constituents. Because of the differing nature of health endpoints, slightly different approaches are used for estimation of impacts of exposure to radionuclides and chemicals. For radionuclides, impacts are estimated as dose and risk. Cumulative impacts of a mixture of radionuclides are estimated as the sum of dose or risk of the individual radionuclides. For chemicals, health impacts are represented as hazard quotient for noncarcinogens and as risk for carcinogens. Cumulative impacts of a mixture are represented as the sum of the hazard quotients, termed “hazard index,” of the individual chemicals, or as the sum of risk of the individual chemicals.

G.2.1 Residual Radioactive Material

Estimation of impacts of residual radioactive contamination of surface soil were estimated using the RESRAD computer code (Yu et al. 1993) developed for the Formerly Utilized Sites Remedial Action Program. RESRAD estimates annual dose to an individual who establishes a residence on a site having residual contamination, raises and consumes crops, raises livestock and consumes meat, poultry and milk, drinks contaminated groundwater, and obtains fish from a contaminated pond. Use of the model for site-specific application requires selection of appropriate operating modes of the model and specification of values for parameters characterizing site physical conditions and the range of likely activity of the individual. The West Valley Site comprises two areas, the North Plateau and the South Plateau, having different physical properties. In particular, geohydrologic analysis has determined that use of a well is feasible on the North Plateau but not on the South Plateau. The three-dimensional site-wide groundwater model predicts that although horizontal flow occurs in the Kent recessional sequence, the unit is unsaturated below both the North and South Plateaus. More detail on the three-dimensional groundwater model is presented in Appendix E. Given the above considerations, exposure pathways included in this analysis are:

- Direct radiation,
- Inhalation of volatile compounds,
- Inhalation of dust,
- Ingestion of vegetables, grain, fruits, meat, poultry, and milk, and
- Inadvertent ingestion of soil

for both the North and South Plateaus and ingestion of drinking water on the North Plateau. The RESRAD code was executed for each radionuclide for a unit source concentration. The result of the analysis was a set of unit dose and risk factors that allow calculation of impacts for differing initial concentrations of each radionuclide in soil. Dose and risk for contact with residual contamination of surface soil by a single radionuclide through the above pathways are estimated as:

$$D_{\text{rsc}} = D_{\text{rf}} C_{\text{s}} \quad (\text{G-1})$$

$$R_{\text{rsc}} = R_{\text{rf}} C_{\text{s}} \quad (\text{G-2})$$

where:

- D_{rsc} = dose due to contact with residual contamination in soil, rem per year
- D_{rf} = unit dose factor for resident farmer pathways, (rem per year) per (picocurie per gram)
- R_{rsc} = risk due to contact with residual contamination in soil, 1 per year
- R_{rf} = unit risk factor for resident farmer pathways, (1 per year) per (picocurie per gram)
- C_{s} = concentration of radionuclide in soil, picocurie per gram

For the case of free release of an area, the unit dose factors may be used in conjunction with a dose criterion to calculate allowable levels of the radionuclide in soil. The allowable levels for a single radionuclide are termed derived concentration guidelines (DCGL) and are calculated as:

$$DCGL = D_c / D_{rf} \quad (G-3)$$

where DCGL has units of picocuries per gram of soil, D_c is the dose criterion (rem per year) and D_{rf} is defined above. For mixtures of radionuclides, the contribution of each radionuclide is incorporated into a DCGL referenced to a single radionuclide using the formula:

$$DCGL_j = 1 / (\sum f_i / DCGL_i) \quad (G-4)$$

where:

$DCGL_j$ is the mixture DCGL referenced to radionuclide j,

$DCGL_i$ is the DCGL for individual radionuclide i, and

f_i is the ratio of concentration of individual radionuclide I to the reference radionuclide j, and the summation is taken over all radionuclides in the mixture.

Parameter values selected for the West Valley Site and the results of RESRAD analysis are presented in Appendix H.

G.2.2 Residual Chemical Constituents

For hazardous chemicals, hazard and risk for residential farmer exposures are estimated using algebraic equations for inadvertent ingestion of soil, inhalation of fugitive dust, and ingestion of drinking water, crops, meat and milk consistent with agency guidance (EPA 1996, 1999, 2000).

G.2.2.1 Inadvertent Ingestion of Soil

For inadvertent ingestion of soil, intake of a chemical constituent is estimated as:

$$I_{si} = [(IR_s EF_{si} ED_{si}) / (BW AT)] C_s \quad (G-5)$$

where:

I_{si} = intake rate for chemical constituent by inadvertent ingestion of soil, milligrams per (kilogram-day)

IR_s = rate of inadvertent ingestion of soil, milligrams per day

EF_{si} = exposure frequency for inadvertent ingestion of soil, days per year

ED_{si} = exposure duration for inadvertent ingestion of soil, years

C_s = concentration of chemical constituent in soil, grams per gram

BW = body weight, kilograms and

AT = averaging time, days.

Hazard quotient (HQ) for the chemical constituent is calculated as:

$$HQ_{si} = I_{si} / RfD \quad (G-6)$$

where:

HQ_{si} = hazard quotient for ingestion of chemical constituent by inadvertent ingestion in soil, unitless and

RfD = Integrated Risk Information System (IRIS) reference dose for chronic ingestion of the chemical constituent, milligrams per (kilogram-day).

I_{si} is defined above.

Risk for the chemical by inadvertent ingestion in soil is calculated as:

$$R_{si} = I_{si} SF_{ing} \quad (G-7)$$

where:

R_{si} = lifetime risk (unitless), and

SF_{ing} = IRIS slope factor for ingestion of the chemical constituent, 1 per milligram per (kilogram day) and

I_{si} is defined above.

G.2.2.2 Inhalation of Fugitive Dust

For inhalation of a contaminant in fugitive dust, intake concentration is calculated as:

$$I_{fd} = \{ (f_m/PEF) EF_{fd} ED_{fd} [ET_o + (ET_i DF_i)] C_s \} / AT \quad (G-8)$$

where:

I_{fd} = intake concentration of chemical constituent in fugitive dust, milligrams per cubic meter,

PEF = particulate emission factor, cubic meters per kilogram

EF_{fd} = exposure frequency for inhalation of fugitive dust, days per year

ED_{fd} = exposure duration for inhalation of fugitive dust, years

ET_o = exposure time fraction, outdoors, unitless

ET_i = exposure time fraction, indoors, unitless

DF_i = dilution factor for indoor inhalation of fugitive dust, unitless

f_m = conversion constant, 1×10^6 milligrams per kilogram, and

C_s and AT is as defined above.

The hazard quotient is calculated as:

$$HQ_{fd} = I_{fd} / RfC \quad (G-9)$$

where:

HQ_{fd} = hazard quotient for inhalation of the chemical constituent in fugitive dust, unitless

RfC = IRIS reference concentration for inhalation of the chemical constituent, milligrams per cubic meter, and

I_{fd} is as defined above.

Lifetime risk due to inhalation of the constituent in fugitive dust is:

$$R_{fd} = I_{fd} SF_{inh} \quad (G-10)$$

where:

- R_{fd} = lifetime risk for inhalation of the chemical constituent in fugitive dust, unitless
- SF_{inh} = IRIS slope factor for inhalation of the constituent, 1 per milligram per cubic meter, and

I_{fd} is as defined above.

G.2.2.3 Ingestion of Drinking Water

For ingestion of a chemical in drinking water, intake is defined as:

$$I_{dw} = (f_m / f_t) \{ (IR_{dw} EF_{dw} ED_{dw}) / (BW AT) \} C_c \quad (G-11)$$

where:

- I_{dw} = chronic intake rate of chemical contaminant in drinking water, milligrams per (kilogram-day)
- C_c = concentration of chemical contaminant in water, grams per cubic meter
- EF_{dw} = exposure frequency for drinking water ingestion, days per year
- ED_{dw} = exposure duration for drinking water ingestion, years
- BW = body weight, kilograms
- AT = averaging time, days
- f_m = conversion constant, 1,000 milligram per gram
- f_t = conversion constant, 365 d/yr, and

other variables are as defined above.

For constituents with noncarcinogenic health effects, hazard quotient is calculated as:

$$HQ_{dw} = I_{dw} / RfD \quad (G-12)$$

where:

- HQ_{dw} = hazard quotient for ingestion of the chemical contaminant in drinking water, unitless
- RfD = IRIS reference dose for chronic ingestion of the chemical contaminant, milligrams per (kilogram-day), and

I_{dw} is as defined above.

For carcinogenic constituents, lifetime risk is estimated as:

$$R_{dw} = I_{dw} SF_{ing} \quad (G-13)$$

where:

- SF_{ing} = IRIS slope factor for ingestion of the chemical contaminant, 1 per milligram per (kilogram-day), and

I_{dw} is as defined above.

G.2.2.4 Ingestion of Crops

For ingestion of a chemical constituent in crops, intake is calculated as:

$$I_c = \{ (IR_{vf} + IR_{lv}) (f_m ED_c) TF_p / (BW AT) \} C_s \quad (G-14)$$

where:

- I_c = intake of chemical constituent in crops, milligrams per kilograms per day
- IR_{vf} = consumption rate of vegetables and fruit, kilograms per year
- IR_{lv} = consumption rate for leafy vegetables, kilograms per year
- f_m = conversion factor, 1×10^6 milligrams per kilogram
- ED_c = exposure duration for crop ingestion, years
- TF_p = soil to plant transfer factor for chemical constituent, milligrams per kilogram per milligram per kilogram, and

BW, AT and C_s are as defined above.

Hazard quotient for ingestion of the chemical constituent in crops is calculated as:

$$HQ_c = I_c / RfD \quad (G-15)$$

where:

- HQ_c = hazard quotient for ingestion of chemical constituent in crops, unitless, and

I_c and RfD are as defined above.

Lifetime risk due to ingestion of a chemical constituent in crops is calculated as:

$$R_c = I_c SF_{ing} \quad (G-16)$$

where:

- R_c = lifetime risk due to ingestion of chemical constituent in crops, unitless, and

I_c and SF_{ing} are as defined above.

G.2.2.5 Ingestion of Meat

For ingestion of a chemical in meat, intake is defined as:

$$I_m = (f_m B_v B_m IR_{fm} IR_m ED_m) / (BW AT) \} C_s \quad (G-17)$$

where:

- I_m = chronic intake rate of chemical contaminant in meat, milligrams per (kilogram-day)
- C_s = concentration of chemical contaminant in soil, grams per gram
- B_v = soil to plant transfer factor, unitless
- B_m = bioaccumulation factor for meat, (grams per kilogram) per (gram per day)
- IR_{fm} = ingestion rate of fodder for meat, kilograms/day
- IR_m = ingestion rate of meat, kilograms per year
- ED_m = exposure duration for meat ingestion, year
- BW = body weight, kilograms
- AT = averaging time, days
- f_m = conversion constant, 1,000,000 milligram per kilogram

other variables are as defined above.

For constituents with noncarcinogenic health effects, hazard quotient is calculated as:

$$HQ_m = I_m / RfD \quad (G-18)$$

where:

HQ_m = hazard quotient for ingestion of the chemical contaminant in meat, unitless
 RfD = IRIS reference dose for chronic ingestion of the chemical contaminant, milligrams per (kilogram-day), and

I_m is as defined above.

G.2.2.6 Ingestion of Milk

For carcinogenic constituents, lifetime risk is estimated as:

$$R_m = I_m SF_{ing} \quad (G-19)$$

where:

SF_{ing} = IRIS slope factor for ingestion of the chemical contaminant, 1 per milligram per (kilogram-day), and

I_m is as defined above.

For ingestion of a chemical in milk, intake is defined as:

$$I_{milk} = (f_m B_v B_c IR_{fmlk} IR_{milk} ED_{milk}) / (BW AT) \} C_s \quad (G-20)$$

where:

I_{milk} = chronic intake rate of chemical contaminant in milk, milligrams per (kilogram-day)
 C_s = concentration of chemical contaminant in soil, grams per gram
 B_v = soil to plant transfer factor, unitless
 B_c = bioaccumulation factor for milk, (grams per liter) per (gram per day)
 IR_{fmlk} = ingestion rate of fodder for milk, kilograms per day
 IR_{milk} = ingestion rate of milk, liters per year
 ED_{milk} = exposure duration for milk ingestion, year
 BW = body weight, kilograms
 AT = averaging time, days
 f_m = conversion constant, 1,000,000 milligram per kilogram, and

other variables are as defined above.

For constituents with noncarcinogenic health effects, hazard quotient is calculated as:

$$HQ_{milk} = I_{milk} / RfD \quad (G-21)$$

where:

HQ_{milk} = hazard quotient for ingestion of the chemical contaminant in milk, unitless
 RfD = IRIS reference dose for chronic ingestion of the chemical contaminant, milligrams per (kilogram-day), and

I_{milk} is as defined above.

For carcinogenic constituents, lifetime risk is estimated as:

$$R_{\text{mlk}} = I_{\text{mlk}} SF_{\text{ing}} \quad (\text{G-22})$$

where:

SF_{ing} = IRIS slope factor for ingestion of the chemical contaminant, 1 per milligram per (kilogram-day), and

I_{mlk} is as defined above.

Parameter values selected for estimation of impacts for residential farmer exposure to chemical constituents for the West Valley Site and the results of impact analysis are presented in Appendix H.

G.3 Groundwater Release Scenarios

Models developed for analysis of groundwater release scenarios simulate release of hazardous constituents from above- or below-grade facilities, transport of the constituents in groundwater to an access point, and exposure of receptors to hazardous constituents in groundwater, surface water, or soil. The physical relations of the release, transport, and exposure point elements of the integrated models are represented in **Figure G-2** for the case of access at a drinking water or irrigation well. The three horizontal arrows to the left of this figure represent movement of groundwater through and around the wasteform. The two horizontal arrows to the right of the figure represent movement of contaminated and un-contaminated groundwater to the well. Similar flow configurations apply for the cases of access to near-surface soil and surface water. Important features of the integrated model concept represented in the figure are the nature of flow through the wasteform and the aquifer, the degree of dilution in the aquifer and at the access point and the type of receptor contact with hazardous constituents.

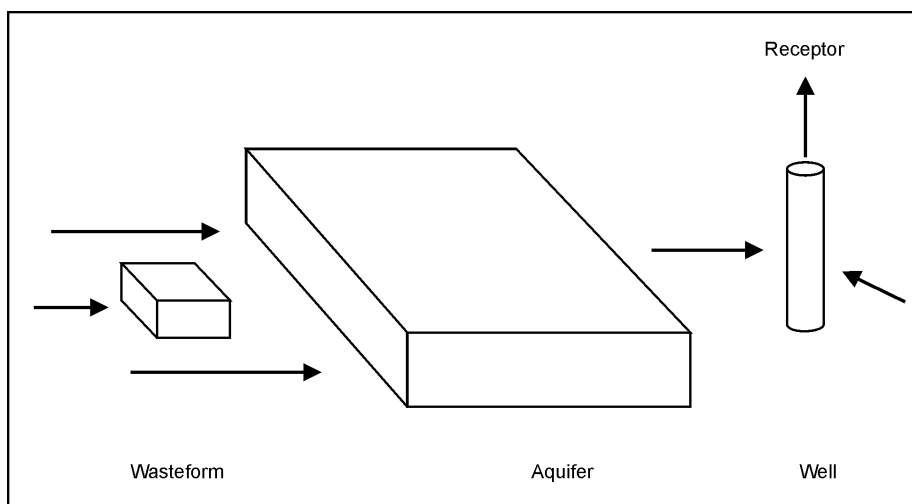

Figure G-2 Concept for Groundwater Scenario Analysis

In the integrated models used to estimate health impacts, flow through the aquifer is represented occurring in one-dimensional flow tubes. The direction of flow and the rate of movement of groundwater in the flow tube were estimated using the three-dimensional near-field flow models described in Appendix E. Similarly, the direction and rate of groundwater flow through wasteforms or disposal areas was estimated using the three-dimensional near-field flow models. Groundwater containing hazardous constituents arriving at the access point is diluted either by mixing in a well or by discharge to surface water. The degree of mixing at the well is specified by considering the minimum daily requirement for a family living at the site and engaged in

agriculture. The required quantity of water includes contributions for domestic use and irrigation use. For domestic use, the quantity was estimated using the average of family size for Cattaraugus County and New York State (Census Bureau 2001) and the average per capita water use rate for New York State (Beyeler et al. 1999). For irrigation use, the quantity was calculated using estimates of garden size meeting family needs and the average irrigation rate for New York State (Beyeler et al. 1999). If the volumetric flow rate through the flow tube representing the aquifer flow is below the minimum required well production rate, the entire plume is captured by the well and constituent concentrations are diluted by mixing into a volume equal to the productivity of the well. If the flow rate within the flow tube exceeds the minimum well productivity, additional dilution does not occur and the concentration in the well is the concentration in the groundwater within the flow tube. If the groundwater discharges to surface water at the access point, concentrations in the surface water are determined by the magnitudes of the flow of groundwater containing hazardous constituents and the flow of surface water. The groundwater is assumed to completely mix in the surface water.

Four types of access points are defined to cover the range of conditions expected at the West Valley Site. At the first type of access point, a receptor uses groundwater obtained from a well for drinking water. At the second type of access point, a receptor uses groundwater obtained from a well for drinking water and garden irrigation purposes. At the third type of access point, a receptor uses groundwater for drinking water and grows a garden in soil in direct contact with groundwater containing hazardous constituents. At the fourth type of access point, groundwater discharges to surface water and the surface water is used for drinking water and fish consumption and for irrigation of a garden. The mixing model assumes complete dilution in the average annual flow rate of the stream. Sensitivity of estimates of impact to change in annual conditions is considered in Appendix H. Also at the point of discharge of groundwater to surface water, groundwater contaminates creek bank soil. Recreational hiking along this section of creek and consumption of vegetation along the creek bank by deer introduces recreational and deer consumption pathways for this type of access point. Impacts of use of surface water from this type of point are mitigated by dilution in surface water. Combinations of these four types of access points comprise the resident farmer scenario for groundwater release scenarios.

Two sets of four computerized integrated impact models, incorporating three different release models and two different groundwater transport models were developed for analysis of releases from West Valley facilities using the integrated model concept described in the preceding paragraphs. One set of codes was used to estimate impacts for radioactive constituents while the other set of codes was used to estimate impacts for chemical constituents. Corresponding codes within the two sets are identical in upper level approach and structure of the disposal facility release model. The corresponding codes differ in values of physical properties for the two classes of constituents and in the models translating concentration in environmental media into impacts. These differences are reflected in the discussion of human health effects impact models presented in Section G.3.4. The discussions of modeling of disposal facility release and groundwater transport are presented for a generic constituent with the understanding that this constituent could be either a radioactive or chemical constituent.

Each of the eight integrated codes comprise executive routines and three major modules simulating hazardous constituent release, groundwater transport, and impacts on human health. For each code; the structures of the executive routines are similar, the exposure modules are identical and the release modules reflect differences in type of release model and facility geometry and design. The balance of this section discusses the structure of the integrated codes and the details of the release, groundwater transport and exposure modules.

G.3.1 Structure of Integrated Codes

Calculation of estimates of impact for the integrated model concept involves data management, logical control, and computational tasks. Data input and output operations, internal transfer of data, control of module calculations, and some calculation tasks are performed in the executive routine.

Two types of release model were developed, one for localized sources such as stabilized rubble or tanks and one for a distributed source such as groundwater combination of the North Plateau Plume. For localized sources, estimation of rate of release of hazardous constituents to groundwater and the concentration of the constituents in groundwater at the release point to the aquifer are performed in the release module. The primary results returned to the executive routine are rate of release to the aquifer for each constituent and the magnitudes and durations of a sequence of concentration pulses of each hazardous constituent at the release point in the aquifer. Data defining each pulse are magnitude of concentration and a start and end time. The duration of a pulse is referred to as a release period. In the groundwater transport model used in conjunction with localized sources, the concentration of a constituent in groundwater at a specified point in the aquifer due to a step function in concentration of the constituent at the release point to the aquifer is calculated. The concentration is calculated as the quotient of the release rate predicted by the release model and the flow rate predicted by the near-field groundwater flow model. The principle of superposition is used in conjunction with the step function response of the groundwater transport module to construct the response to the series of concentration pulses provided by the release module. Logical control of the superposition process is performed in the groundwater transport module. The algorithm used to control the superposition calculation is discussed in Section G.3.3.1 in conjunction with the groundwater transport module. For distributed sources, the release model is an input data specification of initial concentration of the constituent as a function of location within the aquifer. The groundwater transport model used for distributed sources is a finite difference solution of the transport equation that supplies estimates of concentration of the constituent in groundwater and soil and flux of the constituent at specified locations. The approach for specification of initial concentration in the North Plateau Plume is described in Appendices E and H. For both types of groundwater transport model, calculated groundwater and soil concentrations are transferred to the health impacts module where dose and risk (radionuclides) or hazard quotient and risk (hazardous chemicals) due to exposure in groundwater, soil or surface water are estimated.

The order of calculations performed in the integrated model is depicted in the two-part flowchart of **Figure G-3**. Input data includes information specifying the total time for the simulation, the receptor type and intake rates, the numbers of periods of three types of time intervals used to facilitate the calculations, wasteform and aquifer parameters, and physical properties of radiological and chemical constituents used in the calculations. The three types of time intervals are identified as impact, release and data periods. An impact period is the length of time between successive calculations of human health impacts. Generally, the length of an impact period is specified as one year but intervals of ten or one hundred years may be used if the total length of time simulated is large. Human health impact are estimated for the single year at the beginning of the impact period and all years of the impact period are represented as having this magnitude of impact. As described above, release periods are defined to group release quantities for impact periods (years) into a computationally manageable number of concentration pulses. In order to preserve health impact for the impact period of maximum release, this impact period is saved as an individual release period for each radionuclide. The duration of release periods is greater than the duration of impact periods except for the impact period release in which case the duration of the two types of period are the same. The balance of the total release is distributed over the remaining number of release periods. The algorithm used to consolidate releases is discussed in Section G.3.2.1 in conjunction with the rectangular geometry, analytic solution release model. Data periods are defined to provide for time dependence of physical properties of the engineered barriers, that is, to allow simulation of degradation of properties with time. Rate of movement of groundwater in the wasteform and aquifer and tortuosity of the wasteform grout are parameters whose values may change with time.

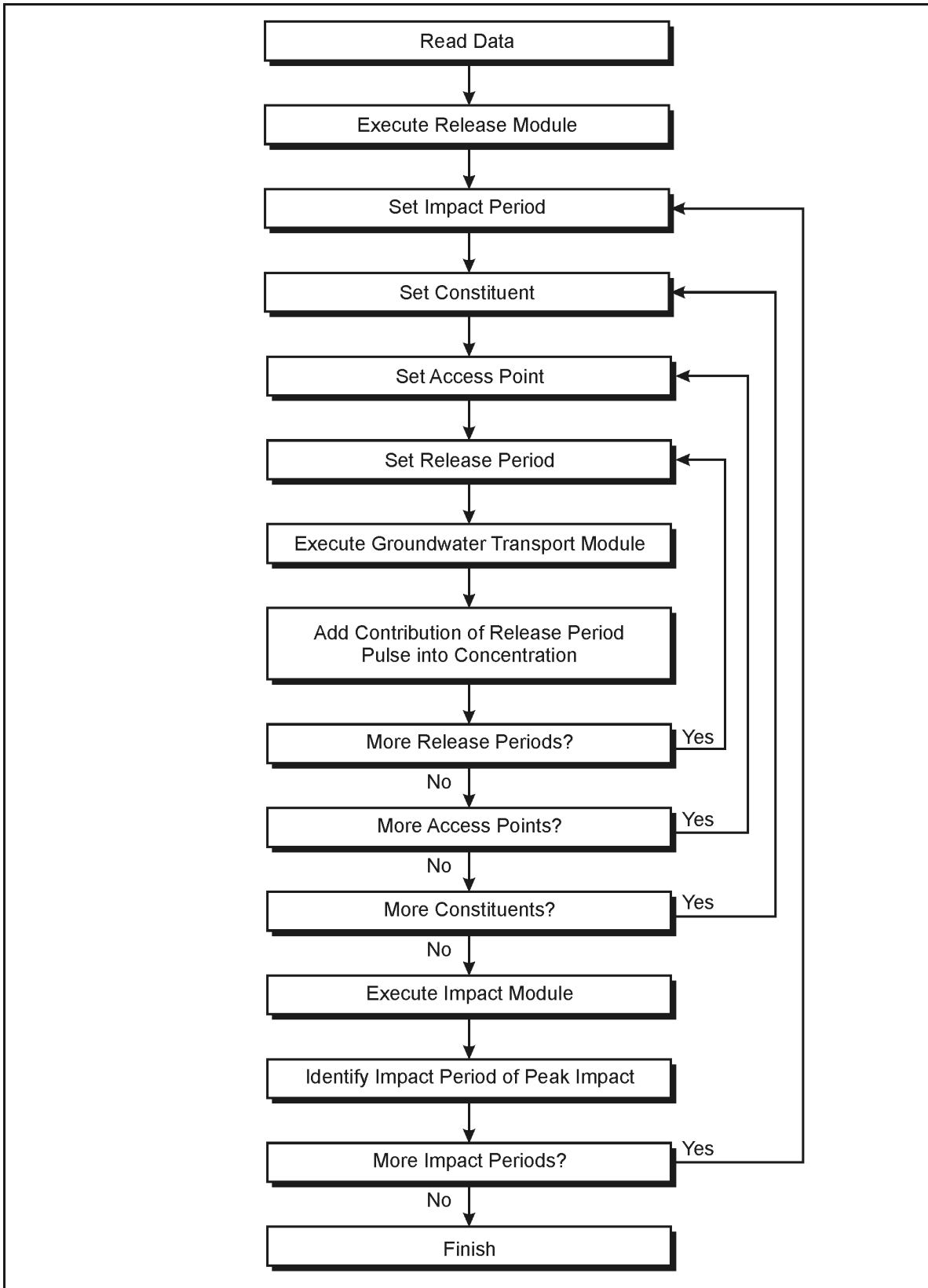

Figure G-3 Organization of Integrated Codes

As indicated in Figure G-3, a simulation begins with reading of input data and estimation of release rates. The calculation proceeds into three loops that provide for calculation of dose for all impact periods, accumulation of contributions of all hazardous constituents, and consideration of all locations defining receptor exposure modes. On completion of the calculation loops, output data for each constituent and location for the impact period of largest annual dose and the time sequence of total dose for all impact periods are transferred to output data files.

Three release modules have been developed for simulation of West Valley facilities. The models incorporate flexible representation of closure concepts allowing simulation of the range of conditions and designs expected in environmental impact statement (EIS) alternatives. The release models differentiating these combinations are a one-dimensional, rectangular geometry analytic model; a one-dimensional rectangular geometry, finite difference model; and a two-dimensional, cylindrical geometry finite-difference model. The nature of these release models is described in the following paragraphs in order of increasing complexity.

G.3.2 Release Modules

G.3.2.1 Rectangular Geometry, Analytic Release Model

Closure designs developed for the West Valley Site incorporate external barriers with waste forms that may be represented as rectangular prisms oriented perpendicular to groundwater flow. A site specific wastefrom design with this geometry and using a tumulus (multi-layer, engineered cap) and external barriers upstream and downstream of the wastefrom is depicted in **Figure G-4**. In the integrated facility, the tumulus is placed at or aboveground level and the layered waste form is oriented horizontally or vertically below the tumulus. The external barriers and the wastefrom have low hydraulic conductivity to limit movement of groundwater through the residual contamination. In addition, the wastefrom may contain sorbents that decrease liquid phase concentrations of hazardous constituents and retard their movement. A generic model which contains a french drain located up-gradient of the slurry wall would divert groundwater away from the residual contamination reducing the water table within the facility to a level near the bottom of the french drain. The drainage layer of the tumulus has high hydraulic conductivity to divert infiltration away from the wastefrom. In Figure G-4 applied to the North Plateau, the primary flow path is horizontal flow through the Surficial Sand and Gravel Unit. In Figure G-4 applied to the South Plateau, the potential flow paths are horizontal flow through the weathered Lavery till or vertical flow through the weathered Lavery till and unweathered Lavery till followed by horizontal flow through the Kent recessional sequence. On both the North and South Plateaus, a slurry wall would be placed in the flow system for the Sitewide Close-In-Place Alternative.

The following paragraphs discuss models for calculation of release rates from the wastefrom. The models are able to estimate impacts for horizontal or vertical flow through a wastefrom but not for both directions simultaneously. For a facility having releases in both directions, as may occur on the South Plateau, the model is executed for each direction separately and the impacts are accumulated as appropriate. For the North Plateau, the model is used to simulate releases from the Main Plant Process Building, the Vitrification Facility, the Low-Level Waste Treatment Facility and the Waste Tank Farm for the No Action Alternative and from the Low-Level Waste Treatment Facility for the Sitewide Close-In-Place Alternative. This type of model is selected for this alternative because rates of flow are high and the spatial distribution of contaminant within the waste form is secondary to the magnitude of the inventory in determining rate of release. For the South Plateau, the model is used to simulate releases from the NDA and SDA for the No Action and Sitewide Close-In-Place Alternatives. This type of model is selected for those cases because rates of flow through the waste form are relatively high and the spatial distribution of contamination may be considered uniform. A schematic of a layered wastefrom with central residual contamination layer and external grout and clay layers is presented in **Figure G-5**.

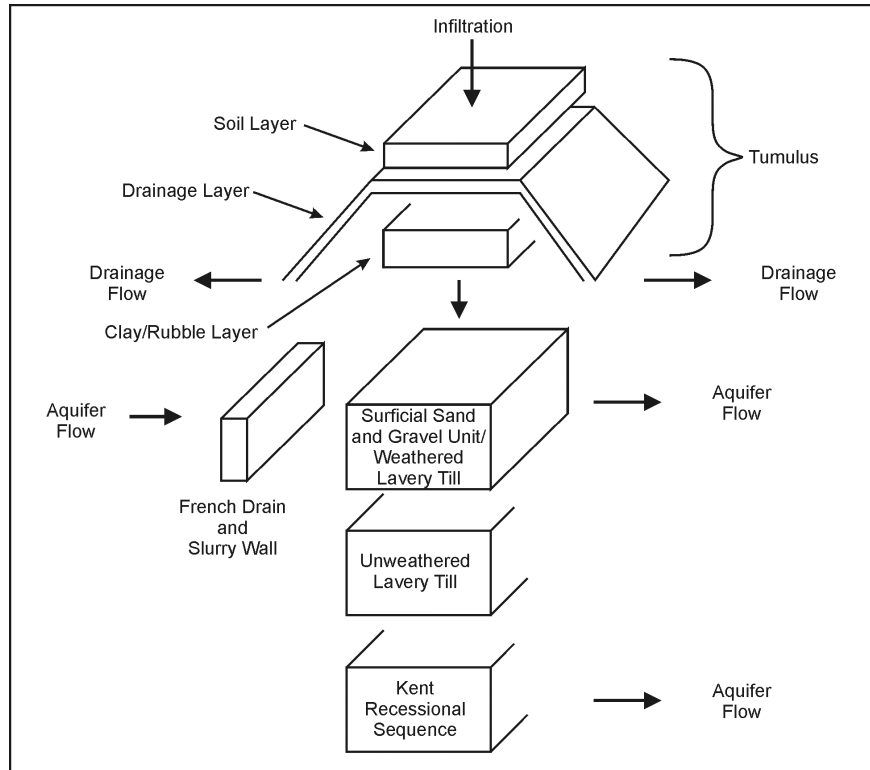

Figure G-4 Disposal System Schematic with Tumulus, French Drain, and Slurry Wall

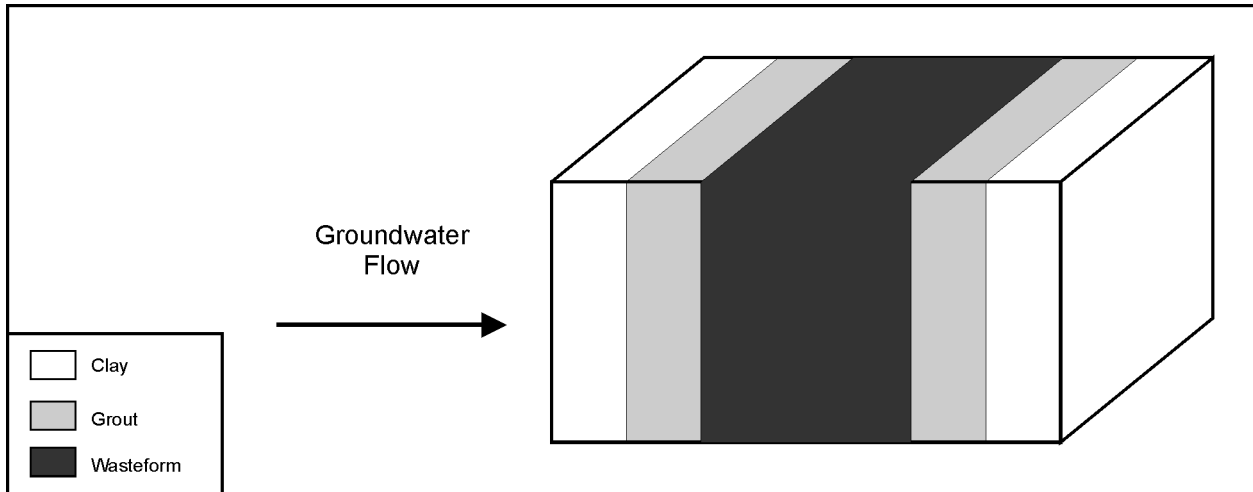

Figure G-5 Schematic for a Layered, Rectangular Geometry Wasteform

Release Model

When release rates due to diffusive or dispersion mechanisms are small relative to release rate due to advective flow, release rate from the wasteform may be calculated in an analytic form. The approach for this model is to use an analytic relation to calculate release rate from the wasteform for a sequence of time periods, thereby representing the continuous release as a sequence of discrete pulses. The pulses then move through the external barriers and enter the surrounding aquifer. Flow rate of water in the aquifer approaching the wasteform may be equal to or greater than the flow rate through the wasteform. Two cases covering the range of mixing within the wasteform are considered. In the first case, constituents are continuously mixed through the wasteform and

constituent concentration in the wasteform decreases over time due to release from the wasteform and due to decay (radionuclides) or chemical reaction (chemicals). In this case, some quantity of constituent is present in the wasteform for all time and the release continues indefinitely. In the second case, constituents move through the wasteform in plug flow manner and the average concentration in the wasteform is reduced by release and decay or decomposition until the entire inventory of the constituent has been released to the aquifer. In this case, the release lasts for a definite period of time that for certain combinations of parameter values may be relatively short. The following paragraphs describe calculation of release from the wasteform for the two modes of mixing. Following this discussion, transport through the external barriers and grouping of releases into concentration pulses for both modes of mixing is described. As described in Section G.3.1, impact periods are used for specification of time periods for calculation of human health impact and release periods are used to accumulate release quantities and facilitate calculation of concentrations of constituents in groundwater. In this rectangular geometry, analytic solution release model; values of all variables do not change with time and the data period approach is not used.

Well-Mixed Release Model

If constituent concentration in the wasteform is uniform at a given time, mass balances for a constituent may be formulated over both the solid and liquid phases of the wasteform and combined to provide a single differential equation describing constituent concentration within the wasteform. This equation is:

$$dC_1/dt = - \{ Q_w/(\epsilon_{tw} V_w R_w) + \lambda \} C_1 \quad (G-23)$$

where:

- C_1 = constituent liquid phase concentration, grams per cubic meter
- t = time since initiation of release, year
- Q_w = volumetric flow rate through the wasteform, cubic meters per year
- ϵ_{tw} = total porosity of the wasteform, unitless
- R_w = constituent retardation constant, unitless
- V_w = volume of wasteform, cubic meters
- λ = constituent decay or decomposition constant, 1 per year, and

$$R_w = 1 + [(1-\epsilon_{tw})/\epsilon_{tw}]\rho_w K_w \quad (G-24)$$

where:

- ρ_w = wasteform particle density, grams per cubic centimeter, and
- K_w = constituent distribution coefficient, milliliters per gram.

The term on the left hand side of Equation G-23 represents depletion in the waste form while the first and second terms on the right hand side of the equation represent loss by convective flow and decay, respectively.

The above equations apply to each constituent although subscripts representing the individual constituents have been eliminated for this presentation. The initial condition required for solution of this equation is specification of the initial inventory of the constituent in the wasteform. Concentration in the wasteform at any time is:

$$C_1 = I_w/(\epsilon_{tw} V_w R_w) \exp(-a_w t) \quad (G-25)$$

with:

$$a_w = Q_w/(\epsilon_{tw} V_w R_w) + \lambda \quad (G-26)$$

where I_w is the initial inventory of the constituent (grams) in the wasteform and all other variables are as defined above. The instantaneous release rate from the wasteform is given by the product of volumetric flow rate through the wasteform and the constituent concentration in the wasteform. Integration of the instantaneous release rate over a period of time yields the total release for that period of time. This relation is:

$$R_{w,ip} = \{ (Q_w I_w) / (a_w \epsilon_{tw} V_w R_w) \} \{ \exp(-a_w t_b) - \exp(-a_w t_e) \} \quad (G-27)$$

where:

- $R_{w,ip}$ = total constituent release from the wasteform during the impact period, grams
- t_b = time at the beginning of the impact period, year
- t_e = time at the end of the impact period, year, and

all other variables are as defined above. Repeated application of Equation G-27 is used to calculate release quantities for the set of impact periods specified for analysis.

Plug Flow Release Model

In the case of plug flow release from the wasteform, the analytic approach may be extended to simulate a non-uniform initial distribution of constituent concentration. This condition is represented schematically in **Figure G-6** where the non-uniform spatial distribution is represented as a sequence of pulses. The variation in concentration is along the wasteform, parallel to the direction of flow through the wasteform. Specification of this initial condition involves identification of the total constituent inventory of the wasteform, the relative concentration of the pulses, and the length of the wasteform occupied by each pulse. In the plug flow concept, each pulse moves through the wasteform with the release from that pulse beginning when the lead edge of the pulse reaches the boundary of the wasteform and ending when the trailing edge of the pulse reaches the boundary of the wasteform. The concentration of constituent in each pulse decreases by decay or decomposition as the pulse moves through and is released from the wasteform. During movement through the wasteform the length of a pulse remains constant at its initial value but the quantity of material within the wasteform decreases as the pulse is released from the wasteform.

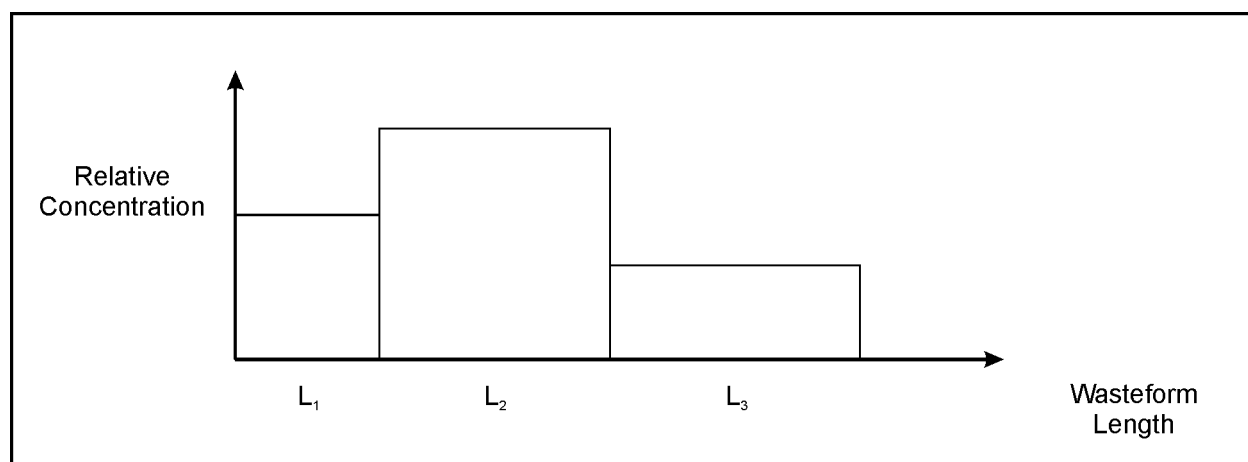

Figure G-6 Schematic of Spatial Distribution of Constituent Concentration for the Plug Flow Analytic Solution Model

As in the case of the well-mixed release model, mass balances for a constituent during its period of release may be formed for the liquid and solid phases and combined into a single differential equation. The mass balance may be expressed as:

$$d(L_p C_1) / dt = [Q_w / (\epsilon_{tw} A_w R_w)] C_1 - (L_p \lambda) C_1 \quad (G-28)$$

where:

- L_p = length of a pulse during its release, meters
- A_w = cross-sectional flow area of the wasteform, square meters, and

all other variables are as defined above for the well-mixed release case. The condition for change in constituent concentration due to decay or decomposition is:

$$d C_1 / dt = -\lambda C_1 \quad (G-29)$$

This relation may be integrated to yield the concentration of a pulse during its release:

$$C_1 = \{ I_p / (\epsilon_{tw} A_w L_p R_w) \} \exp(-\lambda t) \quad (G-30)$$

where I_p is the constituent inventory of a pulse at the initiation of its release and all other variables are as defined above. A relation for the change in inventory of a pulse during its period of release may be derived using Equations G-28 and G-29. The mass balance and decay/decomposition relations may be combined to derive a relation for the rate of change of length of the pulse remaining within the wasteform during its period of release:

$$d L_p / dt = -Q_w / (\epsilon_{tw} A_w R_w) \quad (G-31)$$

This equation may be integrated and re-arranged to derive an expression for the length of time for release (T_p) of a pulse of initial length L_{p0} :

$$T_p = \{ (\epsilon_{tw} A_w R_w) / Q_w \} L_{p0} \quad (G-32)$$

The time for decay or decomposition of any pulse prior to its release (t_d) is then the sum of the time periods of release of all prior pulses.

The instantaneous rate of release from the wasteform is the product of the volumetric flow rate through the wasteform and the constituent concentration in the wasteform at the time of release (Equation G-30). Integration of the instantaneous release rate for a pulse over time yields the release of that pulse for that period of time:

$$R_{w,ip} = \{ Q_w / (\lambda \epsilon_{tw} V_{p0} R_w) \} \{ \exp(-\lambda t_d) I_{p0} \} \{ \exp(-\lambda t_b) - \exp(-\lambda t_e) \} \quad (G-33)$$

where:

- $R_{w,ip}$ = release from a pulse from the wasteform during an impact period, grams
- V_{p0} = volume of the wasteform occupied by a pulse prior to release of any pulse, cubic meters
- I_{p0} = constituent inventory in a pulse before release of any pulse, grams, and

all other variables are as defined above. Repeated application of Equation G-33 is used to calculate release quantities for the set of impact periods specified for analysis.

Movement Through External Barriers

For both the well-mixed and plug flow analytic models, release quantities are determined for a sequence of pulses leaving the wasteform. The external barrier model translates these pulses through the external layers with no change in sequence but with change in length due to adsorption and decrease in magnitude due to decay or decomposition.

In the general case, the analytic release model simulates the presence of two layers surrounding the wasteform. These layers may represent grout curtains or slurry walls with constituent retention capability determined by length and constituent distribution coefficient specified for the particular design under consideration. For example, for a given constituent and volumetric flow rate through the engineered system the travel time for movement of the constituent through a grout layer is given by:

$$T_g = L_g / [Q_g / (\epsilon_{eg} A_g R_g)] \quad (G-34)$$

where:

- T_g = constituent travel time through the grout layer, years
- L_g = length of grout layer, meters
- Q_g = volumetric flow rate through the grout layer, cubic meters per year
- ϵ_{eg} = effective porosity of the grout, unitless
- A_g = flow area of the grout layer, square meters, and
- R_g = constituent retardation coefficient for grout, unitless.

Similar relations apply for slurry wall or clay layers. Within this model concept, the flow area and volumetric flow rates for the external layers (grout, slurry wall or clay) are equal to the flow area and volumetric flow rate for the wasteform.

Given the above considerations, the release quantity for the engineered system is derived from the release quantity for the wasteform by the relations:

$$\begin{aligned} R_{ip} &= 0.0 && \text{for } t < t_t \\ R_{ip} &= R_{w,ipw} \exp(-\lambda t_t) && \text{for } t > t_t \\ ip &= i_{pw} + (t_t / \Delta t_{ip}) \end{aligned} \quad (G-35)$$

where:

- R_{ip} = release from the engineered system during impact period ip, grams
- $R_{w,ipw}$ = release from the wasteform during impact period ipw, grams
- t_t = constituent travel time through all external layers, years, and
- Δt_{ip} = length of time of an impact period, years.

Grouping of Release Pulses

Estimates of human health impacts are calculated on annual basis for long periods of time. In contrast, releases of constituents may occur over shorter periods of time and the intervals of release of differing constituents may or may not overlap. Thus, reporting of release quantity for all constituents for each year of the total time specified for calculation of impact produces inefficient utilization of calculation resources. In order to provide efficient use of analysis resources, release quantities are calculated for each constituent for each impact period specified for calculation of impact but these releases are then grouped into a number of pulses defined for release periods that, in general, are longer in duration than an impact period. Release quantities for release periods are then used in calculation of impacts. Because of the use of maximum impact for comparison with

performance criteria, the approach used for grouping of releases preserves the release for the impact period of maximum release as an individual release period and accumulates the remaining releases into the remaining release periods. Using this grouping approach, periods of high release are represented at greater level of detail than periods of low release allowing more precise estimation of peak impacts. The algorithm used for grouping of releases is presented in **Figure G-7**. Constituent concentration in groundwater at the release point to the aquifer is calculated for each release period by dividing the total release for the release period by the aquifer flow passing around the wastefrom during the release period.

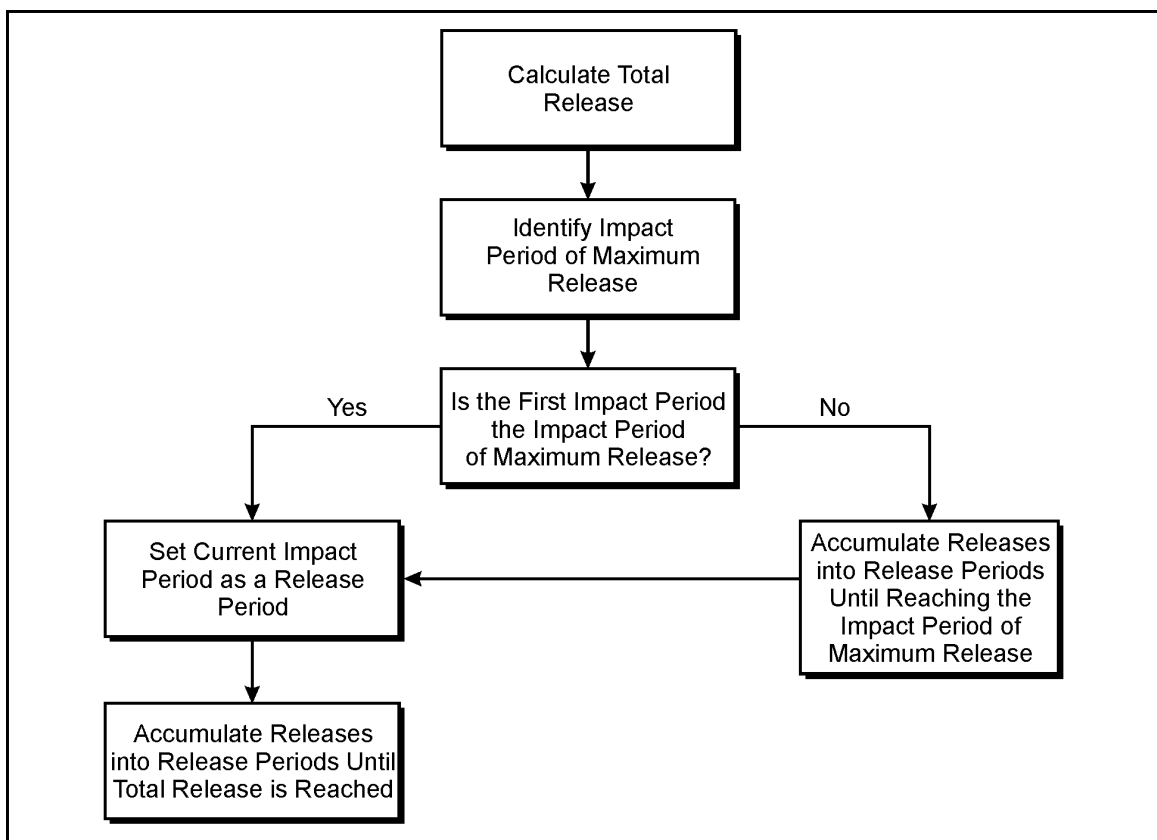

Figure G-7 Algorithm for Grouping Impact Period Releases into Release Period Releases

G.3.2.2 Rectangular Geometry, Finite Difference Release Model

Closure designs under consideration for the Main Plant Process Building, Vitrification Facility and Waste Tank Farm include a tumulus covering an above-grade rubble pile and below grade rectangular wastefroms that may or may not be grouted. The portion of the Surficial Sand and Gravel Unit below the tumulus would be enclosed by a slurry wall for the Sitewide Close-In-Place Alternative. The wastefrom may be comprised of three layers, for example, upper and lower clay layers bounding a grout layer. The primary features of the tumulus are soil, drainage, and clay layers designed to minimize flow rate of water reaching the wastefrom. The drainage layer has high hydraulic conductivity and serves as a preferential flow path routing vertical infiltration away from the wastefrom. The clay and grout layers have low hydraulic conductivity presenting a high-resistance path for flow through the wastefrom. The slurry wall has low hydraulic conductivity and serves to divert horizontal flow around the soil volume below or surrounding the wastefrom. In addition, the grout, clay, and slurry wall layers have sorptive properties that retard radionuclide movement through the system. A schematic diagram of the system is that presented in Figure G-4. Analysis of groundwater flow through the tumulus is presented in Appendix E.

Given the above-described configuration of the natural and engineered systems, constituents may be released to groundwater by diffusive or convective downward movement to the soil zone below the rubble pile or below-grade wasteforms or by horizontal movement through the below-grade wasteforms. The model developed to simulate this system involved calculation of rate of release from the wasteform in downward vertical or horizontal transport to the aquifer surrounding the wasteform. For estimation of release rate from the wasteform, a model of the finite-difference type is needed to simulate the non-uniform spatial distribution of physical properties and radionuclide inventories and the time-dependence of physical properties. The following sections describe elements of the release model.

Wasteform Release Model

The wasteform release model simulates advective, dispersive, and diffusive release of constituents from a rectangular block comprising three layers. The primary direction of flow through the wasteform may be parallel or perpendicular to the primary direction of flow of the aquifer. Physical properties are uniform within each layer but may differ between layers. The interstitial velocity and tortuosity in the central layer of the wasteform may vary with time and the initial spatial distribution of concentration of constituents may vary in the vertical direction. The initial concentration of constituents is specified as a piecewise continuous function of vertical or horizontal position. The time dependence of physical properties is established by definition of a set of data periods within which the values of physical properties are constant. The values of the physical properties may change between data periods. The layered spatial dependence of physical properties is simulated by formation of separate activity balances for each layer and the enforcement of the condition of continuity of flux across the interface between layers (Carnahan, Luther and Wilkes 1969). The mass balance for a constituent for any layer is:

$$R \frac{\partial C}{\partial t} - D \frac{\partial^2 C}{\partial z^2} + v \frac{\partial C}{\partial z} + \lambda RC = 0 \quad (G-36)$$

where:

- R = constituent retardation coefficient, unitless
- C = constituent concentration, grams per cubic meter
- t = time, years
- D = dispersion coefficient, square meters per year
- z = distance in the vertical direction, meters
- v = interstitial velocity, meters per year, and
- λ = constituent decay constant, 1 per year.

The balances are solved using a fully implicit finite difference method defined on a time and one-dimensional space mesh. In this method, the differential equation is replaced by a set of difference equations established at each space node of the wasteform at each time step. The difference forms used are central difference approximation to the first order spatial derivative and Crank-Nicholson approximation to the combination of the time derivative and the second order spatial derivative. At each time step, the difference equations are of the form:

$$\mathbf{A} \mathbf{C} = \mathbf{B} \quad (G-37)$$

where:

- A** = matrix of coefficients ($a_{j,k}$) defined at each space node j, for adjacent nodes, k
- C** = matrix of concentrations (c_k) defined at each space node k; and
- B** = vector of constants (b_j) defined at each space node, j.

This representation is consistent with the differential equation, the solution method is stable, and the solution of the difference equations converges to the solution of the differential equation (Fletcher 1991). The system

of difference equations is of tridiagonal form and is solved using the Thomas algorithm (Fletcher 1991). At the upper boundary of the wastefrom, the concentration is specified as negligible. At the lower boundary, the concentration is established by mixing into the horizontal aquifer flow passing below the wastefrom. The solution method is second order accurate in time and space. Mass balances accumulated throughout the calculations are used to record the accuracy of the solution process. Space and time steps are adjusted in the code in accordance with values of Peclet and Courant number specified as input data.

The order in which calculations are performed for the wastefrom release model is summarized in **Figure G-8**. The initial step is the specification of values of parameters whose values do not change with time and definition of the mesh of space nodes for the specified spatial integration step size. At the next step, data periods are initialized or updated and values of time dependent parameters are established. Next, the matrix of coefficients (**C**) of the set of difference equations is calculated. Values of coefficients within this matrix depend on retardation coefficient, interstitial velocity in the wastefrom, dispersion coefficient, decay constant, and time and space step size but do not change with time within a data period. The index for time steps within a data period is then updated and the vector of constants (**B**) is calculated. Definitions of release, impact and data period are presented in Section G.3.1. Coefficients in this vector depend on physical properties as in the matrix of coefficients but also depend on the values of concentration at the prior time step which are time dependent values. The simultaneous linear equations are solved, yielding the concentration profile at that time step and allowing calculation of release quantity and accumulation of the mass balance. The above steps are repeated for a specified number of time steps within each data period and for all data periods. At this stage, release quantities from the wastefrom have been calculated for all impact periods.

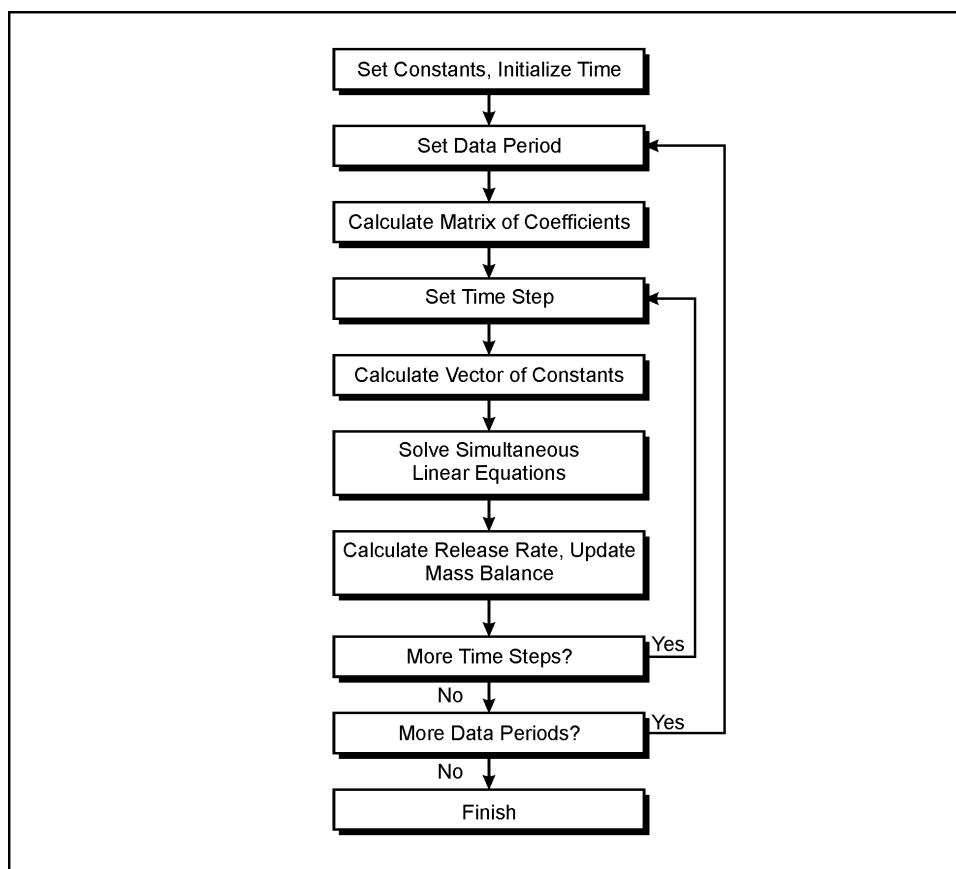

Figure G-8 Solution Algorithm for the Rectangular Geometry, Finite Difference Solution Release Model

The final calculation in this module is grouping of the releases for impact periods into concentrations in the aquifer for release periods. This calculation is performed using the method described in Section G.3.2.1.

Constituent concentrations at the release point to the aquifer are calculated for each release period by dividing the total release for the release period by the aquifer flow passing around the wasteform during the release period.

G.3.2.3 Cylindrical Geometry, Finite Difference Release Model

Closure designs under consideration for the Waste Tank Farm include placement of a tumulus over the tanks, grouting of the interior of the tanks, grouting of the annular space surrounding the tank, and construction of a slurry wall surrounding the tank area. In addition, approximately 3 meters (10 feet) of compacted backfill till surround Tank 8D-1 and Tank 8D-2. The grout, backfill, and slurry wall system have low hydraulic conductivity and divert groundwater flow around the tanks. In addition, the grout and slurry wall components have sorptive capabilities that retard movement of constituents through the system. The tanks are located in an excavation in the thick-bedded unit that extends downward into the unweathered Lavery till and includes a layer of gravel below the tanks. The three-dimensional near-field flow model described in Appendix E indicates that groundwater will enter the excavation and a portion will flow around and through the tanks in the horizontal direction and exit the excavation into the thick Bedded Unit. In addition, a portion of the available groundwater will move downward through the tank into the underlying gravel layer and exit the excavation into the thick-bedded unit and the unweathered Lavery till. A schematic of the tank and adjacent layers of the tank closure system is presented in **Figure G-9**. A schematic of the over-all closure system is presented in Figure G-4.

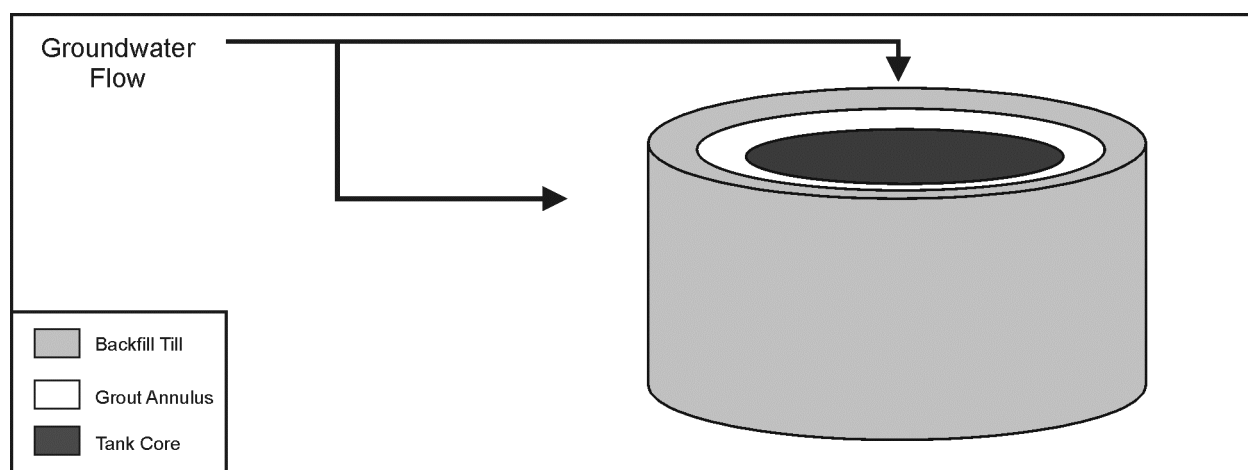

Figure G-9 Schematic of the Tank Closure System

Release may occur by advection, dispersion and diffusion; material properties may change with time and the radionuclide inventory has a non-uniform distribution in the radial direction. For the Close-In-Place Alternative, rates of flow through the tank are low due to the presence of grout, the radial distribution of concentration of contamination may be important in determining rate of release and flow in the horizontal direction may dominate over flow in the vertical direction. In this case, use of the cylindrical geometry, finite difference release model is appropriate. The elements of the release model are described in the following paragraphs.

Release Model

The wastefrom release model simulates advective, dispersive and diffusive release of constituents from a cylinder comprising two layers. Physical properties are uniform within each layer but may differ between layers. The interstitial velocity and tortuosity in the central core of the cylinder, representing the grout core and annulus of the tank, may change with time. The initial spatial distribution of constituent concentration may vary in the radial direction and is specified as a piecewise continuous function of radial position. The time dependence of physical properties is specified through use of a set of data periods. Values of physical properties are constant within a data period but may change between data periods. The spatial dependence of physical properties is simulated by forming separate activity balances in the grout and slurry wall regions and enforcing a condition of equality of flux at the interface between the layers (Carnahan, Luther, and Wilkes 1969). The mass balance for a constituent in any layer is:

$$(\varepsilon_t R) \partial C / \partial t - (\varepsilon_e D) \partial^2 C / \partial r^2 - [(\varepsilon_e D) / r^2] \partial^2 C / \partial \theta^2 + \quad (G-38)$$

$$\varepsilon_e [v_r - (D/r)] \partial C / \partial r + [(\varepsilon_e v_\theta) / r] \partial C / \partial \theta + \varepsilon_e R \lambda C = 0$$

$$D = D_h v_y + (D_w / \tau)$$

$$v_r = -v_y \cos \theta$$

$$v_\theta = v_y \sin \theta$$

where:

- C = constituent concentration in the liquid phase, grams per cubic meter,
- ε_t = total porosity, unitless
- R = constituent retardation coefficient, unitless
- t = time, years
- ε_e = effective porosity, unitless
- D = dispersion coefficient, square meters per year
- D_h = dispersivity, meters
- D_w = constituent diffusion coefficient in water, square meters per year
- τ = tortuosity, unitless
- r = distance in the radial direction, meters
- θ = distance in the azimuthal direction, radians
- v_r = velocity in the r direction, meters per year
- v_θ = velocity in the θ direction, meters per year
- v_y = velocity in the y direction, meters per year, and
- λ = constituent decay or decomposition constant, 1 per year.

The coordinate system used represents the cylinder as divided into four quadrants with azimuthal direction defined as positive in the counter-clockwise direction from the vertical centerline of Quadrant 1. The directions of the coordinate axes are chosen so that the groundwater velocity is parallel to the y direction indicated in **Figure G-10**. The finite difference method used to solve Equation G-38 uses a spatial mesh defined on radial (r) and angular (θ) coordinates on which values of constituent concentration are calculated at a series of time steps. The alternating direction-implicit method is used to represent the differential equation as a set of difference equations. The difference forms are centered for first order spatial derivatives and Crank-Nicholson for the combination of the time derivative and the second order spatial derivatives. The difference equation is consistent with the differential equation, the method is stable and the solution of the difference equations converges to the solution of the differential equation (Fletcher 1991). Concentrations at the

boundary are established by mixing the constituent release into the aquifer flow passing around the wasteform. Time step size is adjusted within the code in accordance with a value of Courant number specified as input data.

The order in which calculations are performed is the same as that represented in Figure G–8 for the rectangular, finite difference release model. The methods differ in that the alternating direction method solves the difference equations twice to proceed through a single time step. On the first pass, concentrations are calculated at an intermediate time along diameters extending from Quadrant 3 through Quadrant 1 using implicit difference forms for derivatives taken with respect to radial position and explicit difference forms for derivatives taken with respect to angular position. Concentrations in Quadrants 2 and 4 are calculated by reflection of these results based on symmetry considerations. On the second pass, concentrations for Quadrants 1 and 2 are calculated for the end of the time step using explicit difference forms for derivatives taken with respect to radial position and implicit difference forms for derivatives taken with respect to angular position. Concentrations for Quadrants 3 and 4 are obtained by reflection of the values for Quadrants 1 and 2. Constituent concentration profile and release to the aquifer are calculated at each time step and release quantity is accumulated over impact periods. The mass balance check is updated at each time step.

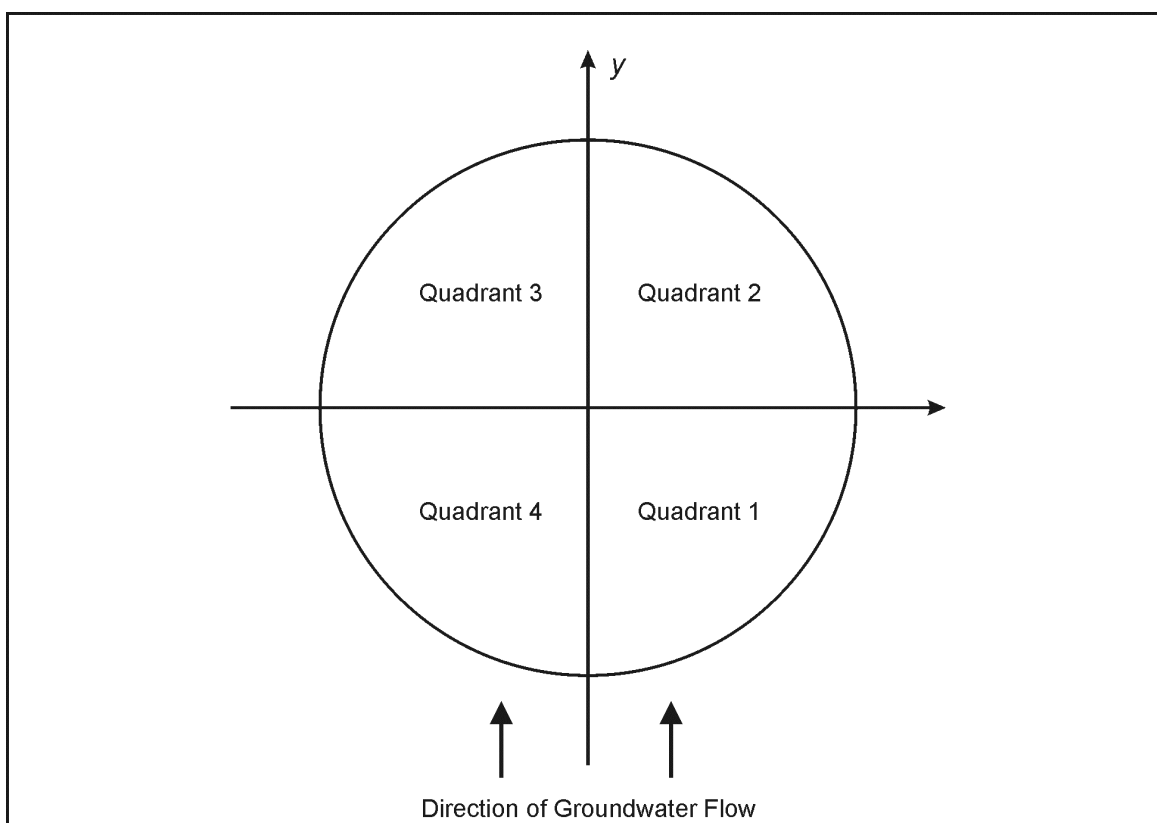

Figure G–10 Schematic of the Cylindrical Model Coordinate System

Grouping of Release Rates

The algorithm used for grouping releases for impact periods into releases for release periods is the same as that described in Section G.3.2.1. Constituent concentration at the release point to the aquifer is calculated for each release period by dividing the release for that release period by the aquifer flow passing around the wasteform during that release period.

G.3.3 Groundwater Transport Module

The concept adopted for analysis of groundwater transport of constituents is that of a flow tube with rectangular cross-section in which groundwater moves at constant velocity and constituents are subject to longitudinal diffusion and dispersion, decay and reversible exchange between the liquid and solid phases in the aquifer. The value of groundwater velocity used in the flow tube model is derived from the three-dimensional groundwater models described in Appendix E. Mass balances for a constituent are formulated in the liquid and solid phases and combined to derive a single partial differential equation for constituent concentration in the aquifer:

$$R \frac{\partial C}{\partial t} - D \frac{\partial^2 C}{\partial x^2} + v \frac{\partial C}{\partial x} + R\lambda C = 0 \quad (\text{G-39})$$

where:

- C = constituent concentration, grams per cubic meter
- t = time, years
- D = dispersion coefficient, square meters per year
- x = position in aquifer, meters
- v = interstitial velocity of groundwater, meters per year
- R = constituent retardation coefficient, unitless, and
- λ = constituent decay or decomposition constant, 1 per year.

Two solutions are developed for this equation: one for localized sources, such as, stabilized facilities and one for distributed sources, such as, the North Plateau Plume. The two solutions differ in the initial and boundary conditions established to complete specification of the model and in the method of solution of the resulting equations.

G.3.3.1 Localized Sources

For localized sources, the initial and boundary conditions used in conjunction with the mass balance are zero concentration throughout the aquifer at time equal to zero ($C = 0$ for all x at $t = 0$) and constant concentration at the release point to the aquifer for all time ($C = C_0$ for all t at $x = 0$). Given these conditions, the solution to the equation may be expressed as (Van Genuchten and Alves 1982):

$$C(x,t) = (1/2) \exp\{ (v-u)x/2D \} \operatorname{erfc}\{X1\} + (1/2) \exp\{ (v+u)x/2D \} \operatorname{erfc}\{X2\}$$

$$u = \sqrt{v^2 + 4\lambda RD}$$

$$X1 = (Rx - ut) / 2\sqrt{DRt} \quad (\text{G-40})$$

$$X2 = (Rx + ut) / 2\sqrt{DRt}$$

where $\operatorname{erfc}(X)$ is the complementary error function of the argument X and all other variables are as defined above.

The functions presented as Equation G-40 describe the concentration in the aquifer caused by a step function in concentration at the release point to the aquifer. In contrast, the release module used in conjunction with this groundwater transport module specifies pulses in concentration at the release point to the aquifer. The response to a pulse function is constructed by adding and subtracting at appropriate time intervals the response to a step function. Thus, a single pulse at the release point to the aquifer is represented as the sum of a positive step function beginning at the start time of the pulse and a negative step function beginning at the end time of

the pulse. The response to multiple pulses is represented by repeated application of the above approach. The algorithm used for this purpose is presented in **Figure G–11**.

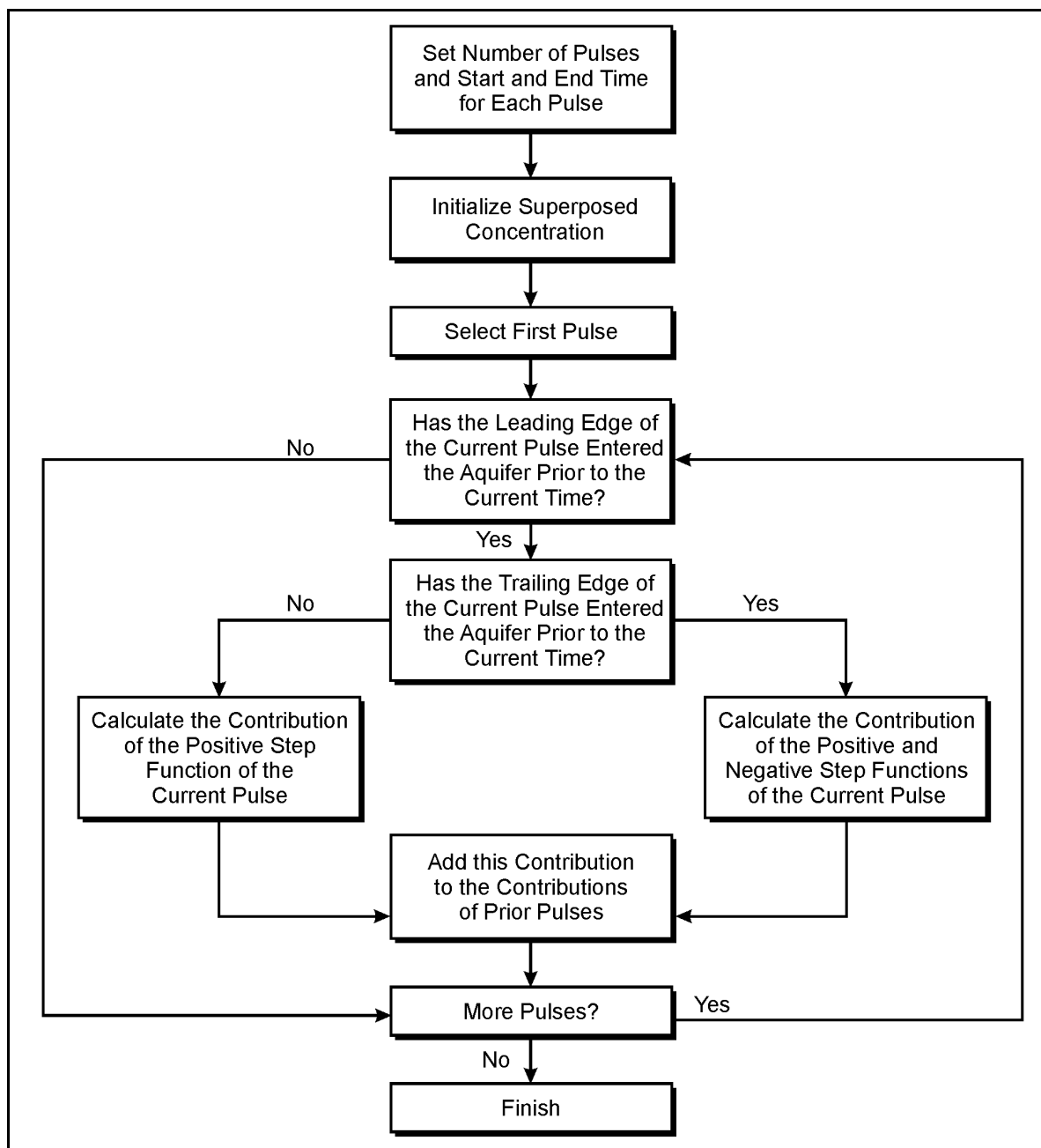

Figure G–11 Algorithm for Accumulation of Concentration Pulses

G.3.3.2 Distributed Sources

The distributed source of primary concern at the West Valley Site is a plume of contamination that developed in the Surficial Sand and Gravel Unit on the North Plateau following a leak of acidic solution from the Process Building. The near-field flow model used in conjunction with the distributed source groundwater transport model is the tumulus and slurry wall combination depicted in Figure G–4. The approach for solution of the groundwater transport equation (Equation G-39) is similar to that described for the rectangular geometry, finite

difference release model. The flow domain is divided into a one-dimensional mesh and the partial differential equation is replaced by a set of algebraic equations using finite difference forms producing an equation set of the form of Equation G-37. Solution of the set of equations provides concentration at nodes defining the mesh and rate of release to the creek located at the upstream end of the flow domain. An initial condition and two boundary conditions are required to solve the set of algebraic equations. The initial condition is specification of concentration of the constituent (radionuclide or hazardous chemical) at each node of the flow domain at the start time for the simulation.

The groundwater velocity is constant throughout the flow domain and the boundary condition specified at the upstream end of the flow domain is zero flux of the contaminant. At the downstream end of the flow domain, the boundary condition is equality of flux of contaminant in groundwater exiting the flow domain and in a mixing cell in the creek receiving the groundwater.

G.3.4 Human Health Effects Impact Module

The human health effects impact module estimates annual impact at a specified time to one of four types of receptors due to exposure to either a radionuclide and its progeny or a hazardous chemical. The three primary functions performed in developing the estimate of impact are calculation of ingrowth and decay, calculation of concentration of hazardous constituents in soil and calculation of measures of health impact for differing types of receptors. Information used to initiate the calculation includes concentration of the parent radionuclide or hazardous chemical in groundwater at the access point, interstitial velocity of groundwater in the aquifer and distance between the release point and the access point. Time for ingrowth and decay is calculated by dividing distance between the release point and the access point by the interstitial velocity of the radionuclide in the groundwater. The interstitial velocity of the constituent in groundwater is the interstitial velocity of the groundwater divided by the constituent retardation coefficient. Physical property information used to support the calculation includes decay constants for radionuclides and hazardous chemicals, decay chain structure for radionuclides, distribution coefficients for all constituents and garden irrigation and infiltration rates. The order in which calculations are performed is represented in **Figure G-12**. The following sections describe methods used to perform the three primary functions.

G.3.4.1 Calculation of Ingrowth and Decay

During transport in groundwater radioactive or chemical constituents may decay or decompose to alternate species. Decomposition or reaction of chemical constituents depends in a complicated manner on site conditions and presence or absence of microbial organisms. Because these conditions are difficult or impossible to know in advance, concentrations of hazardous chemicals were conservatively assumed unaffected by chemical or microbial degradation. Concentrations of radionuclides, however, vary due to ingrowth and decay in predictable, time dependent manner. In order to provide estimates of impact for all potential constituents, the ingrowth of progeny during groundwater transports of their parent nuclides was included in the analysis. The balance of this section describes the method used to estimate rates of ingrowth and decay of radionuclides.

A suite of 72 radionuclides has been developed for consideration in dose analysis. These 72 radionuclides have been organized into 22 decay chains having one or more members. Of the 22 decay chains, 15 include a single radionuclide. The following paragraphs describe the procedure used to calculate ingrowth for decay chains involving one or more progeny.

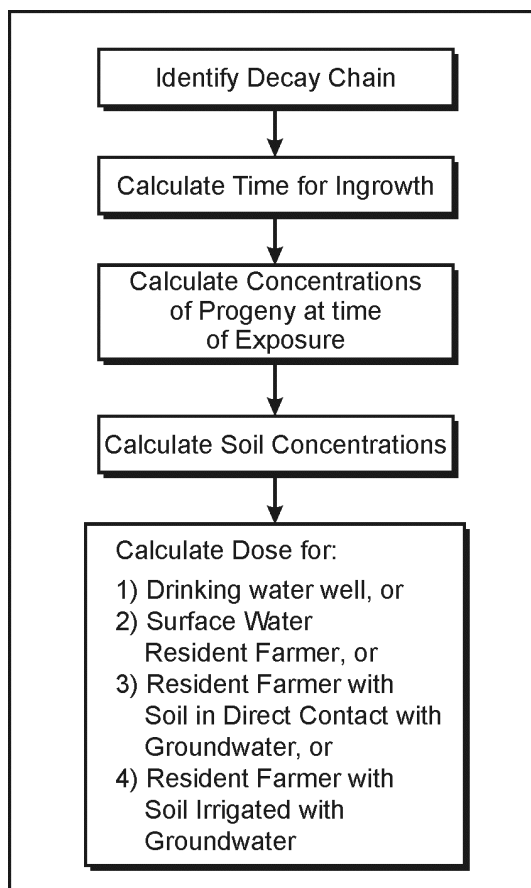

Figure G-12 Order of Calculations for the Human Health Effects Impact Module

A decay chain may be represented as:

$$A_1 \rightarrow A_2 \rightarrow A_3 \rightarrow \dots A_n \rightarrow A_s \quad (G-41)$$

Where A_i represents the i 'th radioactive nuclide in the chain, A_n represents the final radioactive nuclide in the chain and A_s represent the stable nuclide that terminates the chain. The rates of change of the number of atoms of each nuclide may be expressed as:

$$\begin{aligned}
 dN_1/dt &= -\lambda_1 N_1 \\
 dN_2/dt &= \lambda_1 N_1 - \lambda_2 N_2 \\
 &\cdot \\
 &\cdot \\
 &\cdot \\
 dN_i/dt &= \lambda_{i-1} N_{i-1} - \lambda_i N_i
 \end{aligned} \quad (G-42)$$

where N_i and λ_i represent the number of atoms and decay constant of the i 'th nuclide in the chain, respectively. The initial condition adopted for solution of this system of equations is that the number of atoms of the parent (first) nuclide is known ($N_{1,0}$) and all other nuclides are not present initially. The solution to the equations may be expressed as (Benedict, Pigford and Levy 1981):

$$N_1 = N_{1,0} \exp(-\lambda_1 t)$$

$$N_i = N_{1,0} \lambda_1 \lambda_2 \cdots \lambda_{i-1} \left\{ \sum_{j=1}^i \frac{\exp(-\lambda_j t)}{\prod_{\substack{k=1 \\ k \neq j}}^i (\lambda_k - \lambda_j)} \right\} \quad \text{G-43}$$

where all variables are as defined above. The algorithm used for the ingrowth calculation for a given nuclide, initial inventory and time is summarized in **Figure G-13**. Details that support implementation of the algorithm include definition of a unique index for each nuclide, of an index relating a nuclide to its chain and of an index identifying the order of a nuclide in a chain.

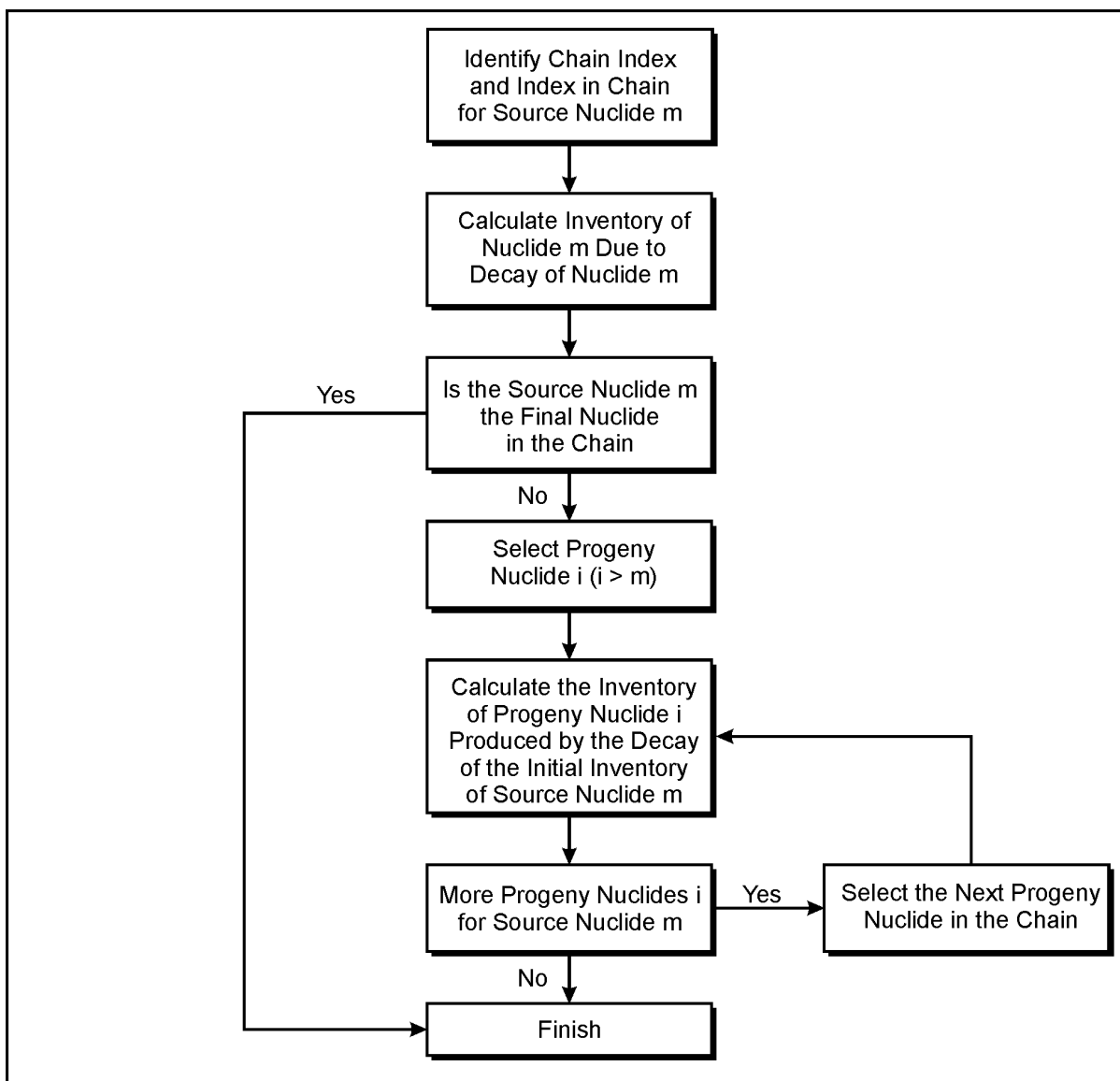

Figure G-13 Algorithm for Radionuclide Ingrowth Calculations

G.3.4.2 Calculation of Concentrations of Hazardous Constituents in Soil

Calculation of concentration of hazardous (radioactive and chemical) constituents in soil is required for two types of exposure scenarios. In the first scenario, groundwater transporting hazardous constituents directly contacts near-surface soil and an individual establishes a residence and garden in the contaminated soil. Because the groundwater transport model represents reversible contact with soil, the concentration of hazardous constituent in soil in contact with contaminated groundwater is given by:

$$C_s = f_v K C_w \quad (G-44)$$

where:

- C_s = concentration in soil of hazardous constituent, grams per gram
- C_w = constituent concentration in groundwater, grams per cubic meter
- f_v = volumetric conversion constant, 1×10^{-6} cubic meters per milliliter
- K = distribution coefficient, milliliters per gram.

In the second type of scenario, water containing hazardous constituents, either contaminated groundwater produced from a well or surface water recharged by contaminated groundwater, is used to irrigate surface soil. An individual establishes a residence and garden in the soil contaminated in this indirect manner. Initially, the constituent is not present in the soil but the concentration develops with time of irrigation. For this case, the concentration of the constituent in soil is determined by a mass balance formed over the volume of surface soil. Variables determining the time-varying soil concentration include the irrigation rate, the infiltration rate and the distribution coefficient of the constituent. The mass balance is:

$$dC_g/dt = - [V_{inf} / (\epsilon_g H_g R_g)] C_g + [V_{irg} / (\epsilon_g H_g R_g)] C_{gw} \quad (G-45)$$

where:

- C_g = constituent concentration in groundwater in the garden, grams per cubic meter
- t = time, years
- V_{inf} = infiltration rate, meter per year
- ϵ_g = porosity of soil in the garden, unitless
- H_g = thickness of soil layer in the garden, meters
- R_g = retardation coefficient for garden soil, unitless
- V_{irg} = irrigation rate, meters per year and
- C_{gw} = constituent concentration in irrigation water, grams per cubic meter.

The solution to this equation is:

$$C_{g,e} = C_{g,b} \exp [-a_g(t_e - t_b)] + (b_g/a_g) C_{gw} \{ 1 - \exp [-a_g(t_e - t_b)] \} \quad (G-46)$$

$$a_g = V_{inf} / (\epsilon_g H_g R_g)$$

$$b_g = V_{irg} / (\epsilon_g H_g R_g)$$

where:

- $C_{g,e}$ = concentration in groundwater in the garden at the end of the time period, grams per cubic meter
- $C_{g,b}$ = constituent concentration in groundwater in the garden at the beginning of the time period, grams per cubic meter
- t_b = time at the beginning of the time interval, years
- t_e = time at the end of the time period, years and

all other variables are as defined above. Equation G-46 is evaluated in each instance the health impact calculation is implemented and the concentration of the hazardous constituent in groundwater in the garden is continuously updated. The concentration of the hazardous constituent in the soil in the garden is:

$$C_{g,s} = f_v K_g C_g \quad (G-47)$$

where:

- $C_{g,s}$ = constituent concentration in soil in the garden, grams per gram
- C_g = constituent concentration in groundwater in the garden, grams per cubic meter
- f_v = volumetric conversion constant, 1×10^{-6} cubic meters per milliliter and
- K_g = distribution coefficient, milliliters per gram.

G.3.4.3 Calculation of Measures of Human Health Impact

Modules calculating dose and risk for radionuclides and hazard quotient and risk for chemical constituents have been developed. The structure of the two modules is the same and each calculates impacts for each constituent of a specified set of constituents at specified times for specified receptor types. For radionuclides, the calculation includes summing over progeny and accumulates the dose and risk due to progeny in the dose and risk due to the parent. Four types of receptor are considered:

- drinking water well receptor,
- surface water receptor,
- residential farmer receptor obtaining drinking water from a well and contacting soil in direct contact with contaminated groundwater, or obtaining drinking water from a well and contacting soil contaminated with irrigation water from a well
- resident without a farm who may engage in recreational hiking.

The following paragraphs describe calculation methods for estimation of impact for these five types of receptor. Exposure pathways for resident farmer receptors are presented in Section G.2.1. Cumulative impacts of a mixture of radionuclides or chemicals are estimated as the sum of the impacts of the individual constituents.

Use of Groundwater for Drinking Water

For a receptor using well water for drinking water, dose due to ingestion of a radionuclide is estimated as:

$$D_{dw} = \Sigma (C_{gw} IR_{dw} DCF_{ing}) \quad (G-48)$$

where:

- D_{dw} = drinking water dose, rem per year
- C_{gw} = radionuclide concentration in groundwater, curies per cubic meter
- IR_{dw} = drinking water consumption rate, cubic meters per year
- DCF_{ing} = dose conversion factor for ingestion, rem per curie and

the summation is taken over radionuclides in the decay chain.

Lifetime risk for the radionuclide is estimated as:

$$R_{dw} = \sum (f_a IR_{dw} ED_{dw} SF_{dw} C_{gw}) \quad (G-49)$$

where:

- R_{dw} = lifetime risk due to ingestion of the radionuclide in drinking water, unitless
- ED_{dw} = exposure duration for the drinking water scenario, years
- SF_{dw} = Health Effects Assessment Summary Table (HEAST) radionuclide-specific slope factor for drinking water ingestion, 1 per picocurie
- f_a = conversion constant, 1×10^{12} picocuries per curie

other variables are as defined above and the summation is taken over radionuclides in the decay chain.

For ingestion of a chemical in drinking water, intake is defined as:

$$I_{dw} = (f_m / f_t) \{ (IR_{dw} EF_{dw} ED_{dw}) / (BW AT) \} C_c \quad (G-50)$$

where:

- I_{dw} = chronic intake rate of chemical contaminant in drinking water, milligrams per (kilogram day)
- C_c = concentration of chemical contaminant in water, grams per cubic meter
- EF_{dw} = exposure frequency for drinking water ingestion, days per year
- BW = body weight, kilograms
- AT = averaging time, days
- f_m = conversion constant, 1,000 milligram per gram
- f_t = conversion constant, 365 days per year, and

other variables are as defined above.

For noncarcinogenic constituents, hazard quotient is calculated as:

$$HQ_{dw} = I_{dw} / RfD \quad (G-51)$$

where:

- HQ_{dw} = hazard quotient for ingestion of the chemical contaminant in drinking water, unitless
- RfD = IRIS reference dose for chronic ingestion of the chemical contaminant, milligrams per (kilogram day), and

I_{dw} is as defined above.

For carcinogenic constituents, lifetime risk is estimated as:

$$R_{dw} = I_{dw} SF_{ing} \quad (G-52)$$

where:

- SF_{ing} = IRIS slope factor for ingestion of the chemical contaminant, 1 per milligram per (kilogram day), and

I_{dw} is as defined above.

Use of Surface Water

Use of contaminated surface water involves drinking water and fish consumption and residential farmer exposure. Discharge of contaminated groundwater to a stream may also contaminate soil along the bank of the stream. The hazard associated with contaminated soil on the bank of the stream is estimated using recreational hiking and deer consumption pathways. Dose for drinking water is calculated using Equation G-48 with the substitution of surface water for groundwater as the source media. Dose for fish consumption is calculated as:

$$D_f = \Sigma \{ C_{sw} (B_f/f_v) IR_f DCF_{ing} \} \quad (G-53)$$

where:

- D_f = dose due to consumption of fish, rem per year
- C_{sw} = radionuclide concentration in surface water, curies per cubic meter
- B_f = radionuclide bioaccumulation factor for fish, picocuries per kilogram per picocurie per liter
- f_v = conversion constant, 1,000 liters per cubic meter
- IR_f = consumption rate for fish, kilograms per year
- DCF_{ing} = dose conversion factor for ingestion, rem per curie, and

the summation indicates accumulation of dose for parent and progeny.

Lifetime risk due to ingestion of the radionuclide in fish is calculated as:

$$R_f = \Sigma [C_{sw} (B_f/f_v) IR_f f_a ED_f SF_f] \quad (G-54)$$

where:

- R_f = lifetime risk for ingestion of contaminant in fish, unitless
- SF_f = HEAST slope factor for food ingestion, 1 per picocurie
- ED_f = exposure duration for fish consumption, years
- f_v = conversion constant, 1,000 liters per cubic meter
- f_a = conversion constant, 1×10^{12} picocuries per curie

other variables are as defined above and the summation is taken over progeny of the parent radionuclide.

Dose due to residential farmer exposure pathways is estimated as:

$$D_{ra} = \Sigma (C_s D_{rf}) \quad (G-55)$$

where:

- D_{ra} = dose for residential farmer, rem per year
- C_s = radionuclide concentration in soil, picocuries per gram
- D_{rf} = RESRAD unit dose factor for residential farmer exposure, rem per year per picocurie per gram, and

the summation is taken over radionuclides in the decay chain.

Lifetime risk due to residential farmer exposure is estimated as:

$$R_{ra} = \Sigma (C_s ED_{ra} R_{rf}) \quad (G-56)$$

where:

- R_{ra} = lifetime risk for residential farmer, unitless
- C_s = radionuclide concentration in soil, picocuries per gram
- ED_{ra} = exposure duration for residential farmer, years
- R_{rf} = RESRAD unit risk factor for residential farmer exposure, 1 per year per picocurie per gram, and

the summation is taken over parent and progeny. For the surface water access point receptor, the radionuclide concentration in soil used in Equations G-55 and G-56 is calculated using Equation G-47.

In the recreational hiking and deer consumption scenarios, groundwater contaminates soil over an area equal to the projection of the area of the contaminated portion of the aquifer on the bank of the stream. In the recreational hiking scenario, an individual walks along the length of the contaminated area each day of the year. Time of exposure per day is determined by dividing the width of the contaminated portion of the aquifer by the rate of walking. Exposure pathways for radionuclides are direct external exposure, inadvertent ingestion of soil, and inhalation of fugitive dust. Unit dose and risk factors for the combined pathways were calculated using the RESRAD computer code (Yu et al. 1993). Dose was estimated as:

$$D_{rec} = \Sigma (f_{Trec} DU_{rec} C_s) \quad (G-57)$$

where:

- D_{rec} = dose due to recreational hiking, rem per year
- f_{Trec} = fraction of time spent in recreation, unitless
- DU_{rec} = unit dose factor for recreation, (rem per year) per (picocurie per gram)
- C_s = concentration of radionuclide in soil, picocurie per gram.

The fraction of time spent hiking was estimated as:

$$f_{Trec} = \Sigma [(1/f_t) W_a EF_{rec}] / V_h \quad (G-58)$$

where:

- f_{Trec} = fraction of time spent hiking, unitless
- f_t = conversion factor for time, hours per year
- W_a = distance (width of the contaminated portion of the aquifer) hiked per day, meters per day
- EF_{rec} = exposure frequency for recreation, days per year
- V_h = hiking speed, meters per hour

Lifetime risk for each radionuclide for recreational hiking was estimated as:

$$R_{rec} = \Sigma (f_{Trec} RU_{rec} ED_{rec} C_s) \quad (G-59)$$

where:

- R_{rec} = lifetime risk due to recreational hiking, unitless
- f_{Trec} = fraction of time spent in recreation, unitless
- RU_{rec} = unit risk factor for recreation, (1 per year) per (picocurie per gram)
- ED_{rec} = exposure duration for recreation, years
- C_s = concentration of radionuclide in soil, picocurie per gram.

For the deer consumption pathway, deer were assumed to consume vegetation growing in the contaminated area of the bank of the stream. The fraction of their daily intake obtained from the contaminated area was estimated as the ratio of the contaminated area to the average range area of a deer. Dose was estimated as:

$$D_d = IR_d C_d DCF_{ing} \quad (G-60)$$

where:

- D_d = dose due to consumption of deer, rem per year
- IR_d = ingestion rate of deer meat, kilograms per year
- DCF_{ing} = dose conversion factor for ingestion, rem per curie
- C_d = concentration of radionuclide in deer meat, picocuries per kilogram

Concentration in deer is estimated as;

$$C_d = B_d IR_{vd} [(\sin \theta_{sb} A_{aq}) / A_d] [f_m / f_a] C_v \quad (G-61)$$

where:

- B_d = bioaccumulation factor of radionuclide in deer meat, (curies per gram) per (curies per day)
- IR_{vd} = ingestion rate of vegetation by deer, kilograms per day
- θ_{sb} = angle of streambank, degrees
- A_{aq} = cross-sectional flow area of contaminated portion of the aquifer, meters squared
- A_d = range area of deer, meters squared
- f_m = conversion factor for mass, grams per kilogram
- f_a = conversion factor for activity, grams per kilogram
- C_v = concentration of radionuclide in vegetation, picocuries per gram

And C_d is defined above. Concentration of radionuclide in vegetation is estimated as:

$$C_v = B_v C_s \quad (G-62)$$

where:

- B_v = soil to plant transfer factor, (picocuries per gram) per (picocuries per gram)
- C_s = concentration of radionuclide in soil, picocuries per gram.

Lifetime risk for ingestion of a radionuclide in deer is estimated as:

$$R_d = B_d IR_{vd} f_m B_v C_s IR_d [(\sin \theta_{sb} A_{aq}) / A_d] ED_d SF_f \quad (G-63)$$

where:

- R_d = lifetime risk for consumption of deer, unitless
- f_m = conversion factor for mass, grams per kilogram
- ED_d = exposure duration for consumption of deer meat, years
- SF_f = slope factor for ingestion, 1 per picocurie

and other variables are as defined above.

For chemical contaminants, intake, hazard quotient and risk for consumption of surface water are calculated using Equations G-50, G-51, and G-52 with the concentration in surface water intake substituted for concentration in groundwater. Intake of a chemical constituent due to consumption of fish is calculated as:

$$I_f = (f_m / f_v) \{ (IR_f ED_f B_f) / (BW AT) \} C_c \quad (G-64)$$

where:

- I_f = intake of chemical contaminant in fish, milligrams per (kilogram-day)
- C_c = concentration of chemical contaminant in surface water, grams per cubic meter
- IR_f = consumption rate of fish, kilogram per year
- ED_f = exposure duration for fish consumption, year
- B_f = bioaccumulation factor for chemical contaminant in fish, milligrams per kilogram per milligram per liter
- f_m = conversion constant, 1,000 milligrams per gram
- f_v = conversion constant, 1,000 liters per cubic meter, and

BW and AT are as defined above.

Hazard quotient for consumption of the chemical contaminant in fish is:

$$HQ_f = I_f / RfD \quad (G-65)$$

where:

- HQ_f = hazard quotient for ingestion of chemical contaminant in fish, unitless
- RfD = IRIS reference dose for ingestion of chemical constituent, milligrams per (kilogram day), and

I_f is as defined above.

Lifetime risk due to ingestion of a chemical constituent in fish was estimated as:

$$R_f = IR_f SF_{ing} \quad (G-66)$$

where:

- R_f = lifetime risk, unitless, and
- SF_{ing} = IRIS slope factor for ingestion of the chemical contaminant, 1 per milligram per (kilogram-day).

For residential farmer exposure to a chemical constituent; intake, hazard quotient, and risk are calculated using Equations G-5 through G-22 as described in Section G.2.2.

For recreational exposure to hazardous chemicals during hiking, exposure occurs through the inadvertent soil ingestion and fugitive dust inhalation pathways. Impacts are estimated using Equations G-5 through G-9 adjusted by fraction of exposure time estimated using Equation G-58. For impacts due to consumption of deer, the conceptual approach described above for radionuclides was applied. Intake is estimated as:

$$I_d = \{ B_d IR_{vd} f_m B_v C_s IR_d [(\sin \theta_{sb} A_{aq}) / A_d] ED_d \} / \{ BW AT \} \quad (G-67)$$

where:

- I_d = intake of chemical in deer meat, milligrams per (kilogram day)
- B_d = bioaccumulation factor of chemical in deer meat, (grams per kilogram) per (gram per day)
- IR_{vd} = ingestion rate of vegetation by deer, kilograms per day
- θ_{sb} = angle of streambank, degrees
- A_{aq} = cross-sectional flow area of contaminated portion of the aquifer, meters squared
- A_d = range area of deer, meters squared
- f_m = conversion factor for mass, milligrams per kilogram
- B_v = soil to plant transfer factor, (gram per kilogram) per (gram per kilogram)
- IR_d = ingestion rate of deer meat, kilograms per year
- ED_d = exposure duration for ingestion of deer, years
- C_s = concentration of chemical in soil, gram per gram.

Hazard quotient is estimated as:

$$HQ_d = I_d / RfD \quad (G-68)$$

where:

- HQ_d = hazard quotient for ingestion of a chemical in deer meat, unitless
- RfD = reference dose for chemical, milligrams per (kilogram day)

Lifetime risk due to ingestion of a hazardous chemical in deer is estimated as:

$$R_d = I_d SF_{ing} \quad (G-69)$$

where:

- R_d = lifetime risk due to ingestion of a chemical in deer meat, unitless
- SF_{ing} = IRIS slope factor for ingestion of the chemical, 1 per (milligram per (kilogram-day))

and I_d is defined above.

Soil in Contact with Groundwater

Concentrations of constituents in soil in contact with groundwater are calculated using Equation G-44. Impacts for the residential farmer receptors are calculated using Equations G-55 and G-56 for radionuclides and Equations G-4 through G-21 for chemical constituents.

Soil in Contact with Irrigation Water

Concentrations of constituents in soil in contact with irrigation water are calculated using Equation G-47. Impacts for the residential farmer receptors are calculated using Equations G-55 and G-56 for radionuclides and Equations G-5 through G-22 for chemical constituents.

Use of a Residence Without a Farm

For erosion release scenarios, it is possible that a residence may be established in the vicinity of but not in direct contact with residual contamination exposed by erosion processes. In this case, a receptor may be exposed to external radiation from the residual contamination while living in the residence. In addition, the receptor may be exposed to radioactive and chemical constituents while hiking in the vicinity of the residence. The dose due to exposure to external radiation is estimated as:

$$D_{\text{ext}} = C_s D_{\text{u,ext}} \quad (\text{G-70})$$

where:

- D_{ext} = external dose, millirem per year,
- C_s = concentration of contaminant in soil, picocuries per gram, and
- $D_{\text{u,ext}}$ = unit dose factor for external radiation, (millirem per year) per (picocuries per gram)

For this scenario, impacts accrued during recreational hiking are estimated using Equations G-57 through G-59 for radionuclides and Equations G-5 through G-10 for chemical constituents.

G.4 Intruder Scenario Models

Past practice, current regulatory frameworks and site-specific conditions (Case and Otis 1988, DOE 1999, NRC 1981, 1982) were reviewed to develop a set of three site-specific intrusion scenarios for exposure to radionuclides. These are characterized as home construction, well driller, and recreational intruders. The home construction and well drilling scenarios each involve worker and resident farmer exposure pathways. The condition evaluated for each of the intruders is exposure to near-surface residual contamination having the composition of soil or to near-surface residual contamination. The intruder is present at the site at a series of times specified for analysis, including a delay representing a period of institutional control. The first of the following sections discusses the upper level organization of the model while the second section discusses details of the dose calculation for each of the receptors. Because impacts are dominated by radiological exposure, analysis of intruder scenarios is limited to consideration of radioactive and not chemical constituents.

G.4.1 Organization of the Model

The intruder model comprises two major elements: an executive routine and a dose module. Functions performed in the executive routine include interpretation of input data, control of sequence of calculations, and writing of results to output files. The overall organization of the code is represented in **Figure G-14**. The input data include specification of radionuclides and radionuclide inventories and of time periods for which dose will be estimated. As indicated in this figure, the code cycles through each radionuclide, intruder and time step and calculates dose at each step in the process. Following completion of the calculation of dose at each time step, the code identifies the maximum dose and time of maximum dose for each of the intruders. The time sequence of total dose for each intruder and the dose for each radionuclide for the time of maximum dose for each intruder are provided as output data.

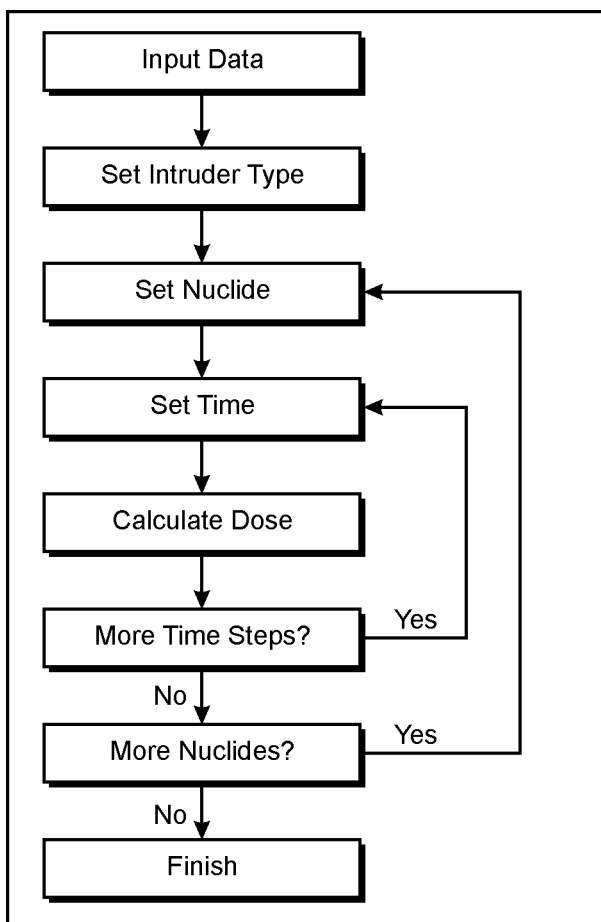

Figure G-14 Organization of Intruder Scenario Analysis Computer Code

G.4.2 Intruder Dose Models

The magnitude of dose estimated for each intruder depends in part on the range of intruder activities. The following sections present equations used for calculation of dose for each type of intruder. Intruder activities and scenario parameter values are consistent with past analyses and current guidance (DOE 1999, Oztunali and Roles 1986, NRC 1981, 1982, 1998, 2000) and dose conversion factors used in the analysis are consistent with current federal guidance (EPA 1988, 1993). Values used for dose factors and model parameters are presented along with simulation results in Appendix H. At each time step during the calculation of dose, radionuclide concentrations are adjusted to reflect decay and ingrowth. The method used for this portion of the calculation is the same as that described in Section G.3.4 and represented schematically in Figure G-14. Cumulative impacts of a mixture of radionuclides are estimated as the sum of the impacts of the individual radionuclides.

G.4.2.1 The Home Construction Intruders

The home construction intruder excavates a foundation for a home and distributes contaminated soil from the excavation into surface soil subsequently used for cultivation of a garden. The excavation work generated airborne dust that was inhaled by the worker. The worker was also simultaneously exposed to direct radiation emitted from radioactive material in the excavation.

The dose due to inhalation of a given radionuclide was estimated as:

$$D_{\text{inh}} = (1 / f_a f_m) M_{\text{load}} \text{BR} T_{\text{exc}} C_{\text{soil}} \text{DCF}_{\text{inh}} \quad (\text{G-71})$$

where:

- D_{inh} = inhalation dose, rem
- M_{load} = mass loading of dust in the air, milligrams per cubic meter
- BR = breathing rate, cubic meters per year
- T_{exc} = time spent in the excavation, year
- C_{soil} = radionuclide concentration in the soil, picocuries per gram
- f_a = conversion factor, 1×10^{12} picocuries per gram
- f_m = conversion, 1,000 milligrams per gram, and
- DCF_{inh} = dose conversion factor for inhalation, rem per curie.

Direct external dose was estimated as:

$$D_{\text{ext}} = N_s \text{DEN}_s C_s T_{\text{exc}} \text{DCF}_{\text{exV}} \quad (\text{G-72})$$

where:

- D_{ext} = external dose, rem
- C_s = concentration of radionuclide in the soil, picocuries per gram
- N_s = number of surfaces in excavation, unitless
- T_{exc} = time spent in the excavation, year
- DEN_s = density of soil, grams per cubic centimeters
- DCF_{exV} = dose conversion for external radiation from a volume source, (rem per year) per (picocurie per cubic centimeter).

Five surfaces, four walls and a floor, and dose factors for semi-infinite media not corrected for finite size of the excavation were used in the calculations.

G.4.2.2 Drilling Intruder

In this scenario, a worker completing a well is assumed to inhale dust mobilized by drilling activity and to be exposed to radiation emitted by residual contamination brought to the surface in drilling mud. Dose due to inhalation was estimated using the same approach as described above for the home construction scenario worker. The drilling mud is pumped to a pond where it is covered by 2 feet of water. The worker remains in the vicinity of the pond and is exposed to direct radiation emitted from the radioactive material in the pond. The activity brought to the surface is:

$$A_{\text{dm}} = f_v (\pi/4) D_{\text{well}}^2 Z_{\text{waste}} \text{DEN}_{\text{waste}} C_{\text{waste}} \quad (\text{G-73})$$

where:

- A_{dm} = activity of a radionuclide in the drilling mud deposited in the pond, picocuries
- f_v = conversion factor, 1×10^6 cubic centimeters per cubic meter
- D_{well} = diameter of the well, meter
- Z_{waste} = thickness of waste horizon, meter
- $\text{DEN}_{\text{waste}}$ = density of waste, gram per cubic centimeter, and
- C_{waste} = radionuclide concentration in the waste, picocuries per gram.

The activity was distributed at the upper surface of the mud layer, below the overlying water. The shielding of the pond water would reduce the dose by a factor of approximately 75. The dose to a receptor near the pond was estimated as:

$$D_{\text{drill}} = [(A_{\text{dm}}/f_a) / A_p] (1.0/f_{\text{shld}}) T_{\text{drill}} \text{DCF}_{\text{exs}} \quad (\text{G-74})$$

where:

- D_{drill} = dose during drilling activity, rem
- A_p = area of pond, square meters
- T_{drill} = time of exposure near pond, year
- f_a = conversion factor, 1×10^{12} picocuries per curie
- f_{shld} = factor for reduction of dose due to shielding by water in pond, unitless
- DCF_{exs} = dose conversion factor for external radiation from a source of surface contamination, (rem per year) per (curie per square meter), and

A_{dm} is as defined above. After completion of drilling activity, drilling mud is removed from the pond and distributed into soil used for cultivation of a garden.

G.4.2.3 Residential Farmer Intruder

In the residential farmer scenario, an individual lives in a home and cultivates a garden on soil containing residual contamination resulting in exposure to radionuclides through a variety of direct radiation, inhalation and ingestion pathways. As described in Section G.2, dose for the residential farmer scenario was simulated using unit dose factors developed using the RESRAD computer code (Yu et al., 1993). For intruder scenarios, contamination of the soil occurs due to distribution of soil excavated from the foundation during home construction or to distribution of mud from the drilling pond.

The amount of a radionuclide brought to the surface during home construction is estimated as:

$$A_{\text{hc}} = W_{\text{exc}} L_{\text{exc}} H_{\text{rmvd}} \rho_w f_v C_w \quad (\text{G-75})$$

where:

- A_{hc} = activity of a radionuclide removed from the excavation during home construction, picocuries
- W_{exc} = width of the excavation, meters
- L_{exc} = length of the excavation, meters
- H_{rmvd} = height of residual contamination removed from the excavation, meters
- ρ_w = density of residual contamination removed from the excavation, grams per cubic centimeter
- f_v = conversion constant, 1×10^6 cubic centimeters per cubic meter and
- C_w = concentration of radionuclide in residual contamination, picocuries per gram.

The activity in drilling mud brought to the surface is that estimated using Equation G-73. The concentration of a radionuclide in soil for residential farmer is estimated as:

$$C_{\text{ra}} = A_{\text{rmvd}} / (A_{\text{ra}} H_{\text{mix}} f_v \rho_s) \quad (\text{G-76})$$

where:

- C_{ra} = concentration of radionuclide in soil for residential farmer, picocuries per gram
- A_{rmvd} = activity removed from the home construction excavation (A_{hc}) or well borehole (A_{dm}), picocuries
- A_{ra} = area required for the residence and garden, square meters
- H_{mix} = height for mixing activity into soil, meters
- f_v = conversion constant, cubic centimeters per cubic meter
- ρ_s = density of soil in the garden, grams per cubic centimeter

Unit impact factors derived using RESRAD allow calculation of dose as:

$$D_{ra} = C_{ra} DCF_{ra} \quad (G-77)$$

where:

- D_{ra} = dose to a residential farmer, rem per year
- C_{ra} = radionuclide concentration in soil, picocuries per gram
- DCF_{ra} = unit dose factor reflecting dose through RESRAD pathways, (rem per year) per (picocuries per gram)

G.4.2.4 Recreational Hiking

In the recreational hiker scenario, an individual hikes through an area with residual contamination of surface soil. Potential exposure pathways are direct external exposure, inadvertent ingestion of soil, and inhalation of fugitive dust. Unit dose factors for the combined pathways were calculated using the RESRAD computer code (Yu et al. 1993). Dose for the recreational hiker was estimated as:

$$D_{rec} = T_{rec} C_{waste} DCF_{rec} \quad (G-78)$$

where:

- D_{tec} = dose for recreational intruder, rem
- T_{rec} = duration of recreational intrusion, year
- C_{waste} = concentration of radionuclide in surface soil, picocuries per gram
- DCF_{rec} = unit dose factors for recreational intrusion, (rem per year) per (picocurie per gram).

G.5 Erosion Collapse Scenario Models

Erosion processes occurring over long time frames have the potential for disruption of facilities at the West Valley Site. Mathematical analysis of potential adverse health impacts related to erosion requires prediction of rates and spatial distribution of erosion and estimation of doses caused by erosion-mediated releases. Methods used to predict the nature and extent of erosion and the results of that analysis are presented in Appendix F. This portion of Appendix G discusses the exposure impact models used to estimate impacts caused by specified types and rates of erosion. Two models were developed for estimation of impacts due to erosion, one for estimation of impacts due to release of radionuclides and one for estimation of impacts due to release of chemical constituents. The upper level structure of the two codes and the release models for the two codes are identical, the codes differ only in methods for calculation of impacts of exposure. The following text describes the common elements of erosion release codes; health impacts are estimated as described in Section G.3.4. Assessment of uncertainty in estimates of impacts for erosion releases is provided by analysis of three cases that bound potential conditions. Parameter values and more complete description of these cases are presented in Appendix H.

The concept adopted for estimation of erosion impacts represents the residual contamination as a rectangular prism that may or may not extend to the ground surface. Erosion is represented as comprised of two components, vertical downward movement of the ground surface and horizontal movement of near-vertical creek banks. The residual contamination is distributed into a number of rectangular below ground prisms referred to as trenches, each of which comprises several sections. Horizontal distribution of constituents is represented by division of the trench into sections located at differing distances from the creek bank. Constituent inventories of each trench section are specified independently and are corrected for decay and ingrowth or degradation as time proceeds. The relation of the residual contamination matrix, ground surface, and creek banks is represented schematically in **Figure G-15**. In this figure, the parameter X_i indicates the distance of the i 'th section of the residual contamination matrix from the creek bank and Z_{gs} , Z_{top} and Z_{bot} indicate positions of the ground surface and top and bottom of the residual contamination matrix, respectively. Radiological and chemical constituents eroded from the residual contamination matrix are deposited into the surface water that is subsequently used by an individual who drinks the contaminated water, consumes fish living in the water and irrigates a garden with the contaminated water. The model developed to analyze this scenario comprises an executive routine and a dose estimation module. The dose estimation module is the same as that described in Section G.3.4 (Human Health Impacts Module) for the surface water pathway. The balance of this section describes the executive routine used to control estimation of impacts.

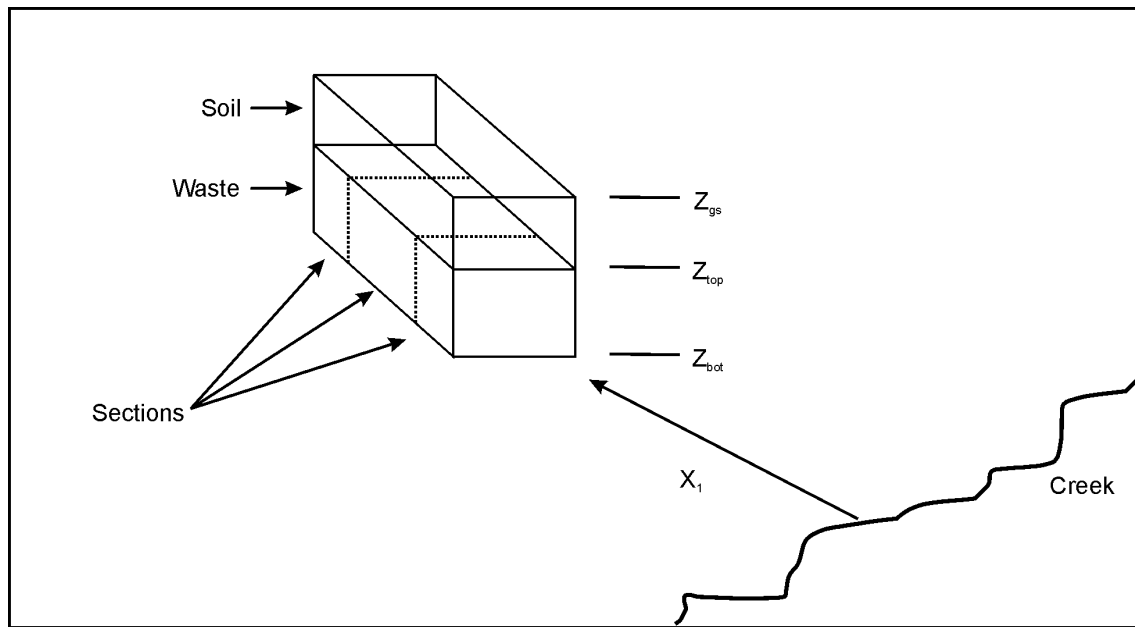

Figure G-15 Concept for Erosion Scenario Impact Analysis

The executive routine developed for this case manages input data, tracks the relative positions of the residual contamination matrix, ground surface and creek bank, controls execution of the health impacts module and reports the results of the analysis. Data defining the scenario include the times at which impact is calculated, the inventories of constituents in each section of each trench, the initial vertical and horizontal position of the boundaries of the residual contamination matrix and the rates of movement of the ground surface and creek bank. Rates of movement of the ground surface and creek banks are specified as piecewise continuous functions of time. Values of these positions at any time are obtained by interpolation between the specified values. The time dependent rates of movement are provided by either the landscape evolution or simple gully models described in Appendix F.

The order of calculations is represented in **Figure G-16**. Following the reading of input data the model sets indices identifying the sections of each trench that are nearest the creek. The model then increments time and

identifies the position of the ground surface and creek bank and compares these positions with the current positions of the top of the residual contamination matrix and of the trench sections nearest the creek. When the ground surface or creek bank intersects boundaries of the residual contamination matrix, that portion of the residual contamination is transferred to the creek. All material transferred to the creek is assumed to be suspended in the flow of the creek and available for bioaccumulation in fish or use by receptors. When all inventories deposited in the creek during the time interval are accumulated, dose is calculated and the model updates positions and inventories of the residual contamination matrix and proceeds to the next time step. After estimation of dose for all specified time steps, the model searches the time sequence of impact and identifies the time of maximum annual impact. The time sequence of impact and the time and magnitude of maximum impact are reported as model results.

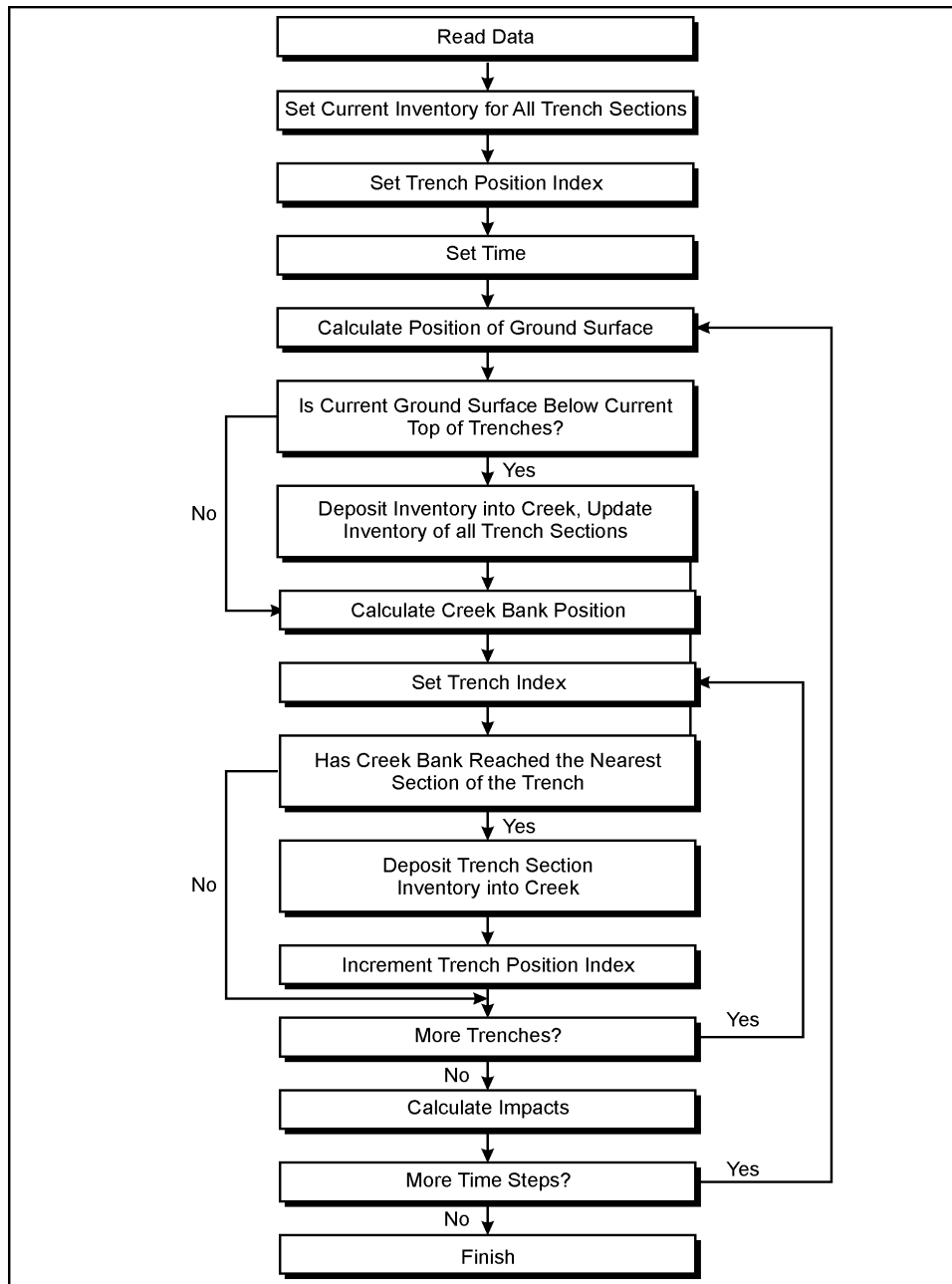

Figure G-16 Algorithm for Erosion Collapse Scenario Impact Estimation

The rate of movement of the ground surface used in the erosion release model may be estimated using the SIBERIA or CHILD landscape evolution models described in Appendix F or using a simple model applicable for an individual gully. In the case of the simple gully erosion model used in this analysis, the conceptual gully shown in **Figure G-17** is represented as having triangular cross-section, a rate of advance that may be a function of time, a rate of downcutting that may be a function of time and a constant angle between the ground surface and the walls of the gully. Given these parameters, the volume of the gully is estimated using a combination of analytic geometry and numerical methods. The volume of soil removed from the residual contamination volume is calculated in similar fashion given specification of the width of the residual contamination volume and the elevation of the upper and lower surfaces of the residual contamination volume.

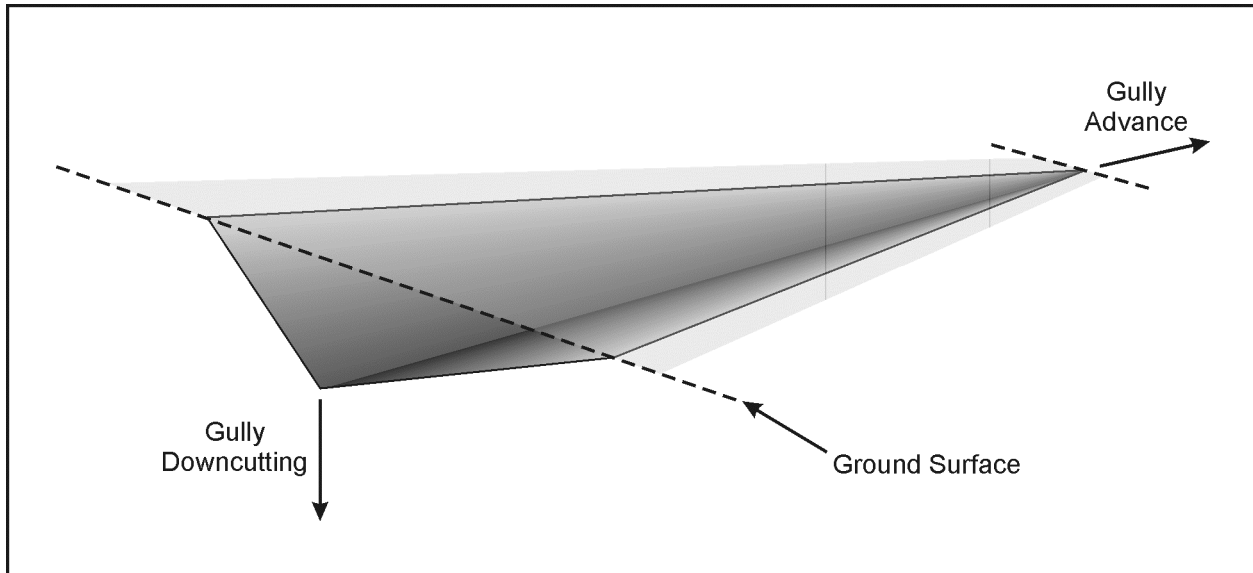

Figure G-17 Schematic of a Simplified Single Gully

G.6 References

Benedict, M., T. H. Pigford and H. W. Levi, 1981, *Nuclear Chemical Engineering*, McGraw-Hill Book Co., New York, New York.

Beyeler, W. E., W. A. Hareland, F. A. Duran, T. J. Brown, E. Kalinina, D. P. Gallegos and P. A. Davis, 1999, *Residual Radioactive Contamination From Decommissioning Parameter Analysis*, NUREG/CR-5512, Volume 3, SAND99-2148, U.S. Nuclear Regulatory Commission, Washington, DC, October.

Carnahan, B., H. A. Luther and J. O. Wilkes, 1969, *Applied Numerical Methods*, John Wiley and Sons, Inc., New York, New York.

Case, M. J., and M. D. Otis, 1988, *Guidelines for Radiological Performance Assessment of DOE Low-Level Radioactive Waste Disposal Sites*, DOE/LLW-62T, Idaho Falls, Idaho, July.

Census Bureau, 2001, *Quick Facts Cattaraugus County, NY*, at <http://quickfacts.census.gov/qfd/states/36/36009.html>.

DOE (U.S. Department of Energy), 1999, *Implementation Guide for Use with DOE M 435.1-1*, DOE G 435.1-, Washington, DC, July 9.

EPA (U.S. Environmental Protection Agency), 1988, *Federal Guidance Report No. 11: Limiting Values of Radionuclide Intake and Air Concentration and Dose Conversion Factors for Inhalation, Submersion, and Ingestion*, EPA-520/1-88-020, Washington, DC, September.

EPA (U.S. Environmental Protection Agency), 1993, *Federal Guidance Report 12: External Exposure to Radionuclides in Air, Water, and Soil*, EPA-402-R-93-081, Washington, DC, September.

EPA (U.S. Environmental Protection Agency), 1996, *Soil Screening Guidance: User's Guide*, EPA/540/R-96/018, Washington, DC, July.

EPA (U.S. Environmental Protection Agency), 1999, *Exposure Factors Handbook*, EPA/600/C-99/001, Washington, DC, February.

EPA (U.S. Environmental Protection Agency), 2000, *Soil Screening Guidance for Radionuclides: User's Guide*, EPA/540/R-00/007, Washington, DC, October.

Fletcher, C. A. J., 1991, *Computational Techniques for Fluid Dynamics*, Volume 1, Springer-Verlag, Berlin, Germany.

NRC (U.S. Nuclear Regulatory Commission), 1981, *Draft Environmental Impact Statement on 10 CFR Part 61 "Licensing Requirements for Land Disposal of Radioactive Waste Summary"*, NUREG-0782, Washington, DC, September.

NRC (U.S. Nuclear Regulatory Commission), 1982, *Final Environmental Impact Statement on 10 CFR Part 61 "Licensing Requirements for Land Disposal of Radioactive Waste"*, NUREG-0945, Washington, DC, November.

NRC (U.S. Nuclear Regulatory Commission), 1993, *Software Quality Assurance Program and Guidelines*, NUREG/BR-0167, Washington, DC, February.

NRC (U.S. Nuclear Regulatory Commission), 1998, *Guidance on Using Decision Methods for Dose Assessment to Comply with Radiological Criteria for License Termination*, NUREG-1549, Washington, DC, February 18.

NRC (U.S. Nuclear Regulatory Commission), 2000, *Standard Review Plan for the Review of Decommissioning Plans and Other Information Submitted to Support the Release of Nuclear Facilities, Appendix C, Technical Basis for Dose Modeling Evaluation*, at <http://techconf.llnl.gov>, June 14.

Oztunali, O. I. and G. W. Roles, 1986, *Update of the Part 61 Impacts Analysis Methodology*, NUREG/CR-4370, Environsphere Co., New York, New York, January.

Van Genuchten, M. T. and W. J. Alves, 1982, *Analytical Solutions of the One-Dimensional Convective-Dispersive Solute Transport Equation*, Technical Bulletin No. 1661, U.S. Department of Agriculture, Washington, DC.

Yu, C., A. J. Zeilen, J. J. Cheng, Y. C. Yuan, L. G. Jones, D. J. LePoire, Y. Y. Wang, C. O. Loureiro, E. Gnanapragasam, E. Faillace, A. Wallo III, W. A. Williams, and H. Peterson, 1993, *Manual for Implementing Residual Radioactivity Material Guidelines Using RESRAD, Version 5.0*, ANL/AED/LD-2, Argonne National Laboratory, Argonne, Illinois, September.