



Department of Energy
Office of Science
Fermi Site Office
Post Office Box 2000
Batavia, Illinois 60510

January 29, 2024

Mr. Marc Clay
Chief Safety Officer, Interim
Fermilab
P.O. Box 500
Batavia, IL 60510

SUBJECT: NATIONAL ENVIRONMENTAL POLICY ACT DETERMINATION AT
FERMI NATIONAL ACCELERATOR LABORATORY – ELECTRIC
VEHICLE CHARGING STATION INSTALLATIONS

References: Memorandum from M. Clay to R. Hersemann; Subject: National
Environmental Policy Act Environmental Evaluation Notification Form for
Electric Vehicle Charging Station Installations; Dated January 17, 2024

Dear Mr. Clay:

The Fermi Site Office (FSO) has reviewed the National Environmental Policy Act (NEPA) Environmental Evaluation Notification Form (EENF) for Electric Vehicle Charging Station Installations. Based on the information provided in the EENF, the following categorical exclusion (CX) is approved:

<u>Project Name</u>	<u>Approved</u>	<u>CX</u>
Electric Vehicle Charging Station Installations	1/18/2024	B5.23

Enclosed is a signed copy of the EENF for your records. No further NEPA review is required. This project falls under categorical exclusions provided in 40 *CFR* 1021, as amended in November 2011.

Placement of Electric Vehicle Charging Station Installations on the Fermilab site must consider the proximity to radiation and other hazards. Concurrence with FSO is expected prior to siting and placement of Electric Vehicle Charging Station Installations.

If you have any questions, please contact Rick Hersemann, of my staff, at (630) 840-4122 or by email at rick.hersemann@science.doe.gov.

Sincerely,

**Roger E.
Snyder**

Roger E. Snyder
Fermi Site Office; Manager

Digitally signed by Roger
E. Snyder
Date: 2024.01.29
13:40:55 -06'00'

Enclosures: As Stated

Cc:

L. Huntoon, FRA

S. Panock, FRA

M. Jeffers, FRA

C. Hurley, FRA

J. Scott, DOE-FSO

R. Hersemann, DOE-FSO

K. Porter, DOE-FSO

A. Harris, DOE-FSO

S. Wallace, DOE-FSO

**FERMI NATIONAL ACCELERATOR LABORATORY
ENVIRONMENTAL EVALUATION NOTIFICATION FORM (EENF)**
for documenting compliance with the National Environmental Policy Act
(NEPA), Department of Energy (DOE) NEPA Implementing Regulations,
and the DOE NEPA Compliance Program of DOE Policy 451.1

Project/Activity Title: Electric Vehicle Charging Station Installations
ES&H Tracking Number: 2023-25931

I hereby verify, via my signature, the accuracy of information in the area of my contribution for this document and that every effort would be made throughout this action to comply with the commitments made in this document and to pursue cost-effective pollution prevention opportunities. Pollution prevention (source reduction and other practices that eliminate or reduce the creation of pollutants) is recognized as a good business practice which would enhance site operations thereby enabling Fermi National Accelerator Laboratory (Fermilab or the Site) to accomplish its mission, achieve environmental compliance, reduce risks to health and the environment, and prevent or minimize future Department of Energy (DOE) legacy wastes.

Fermilab Action Owner: Kerry Aschenbach

Signature and Date  1/11/24

I. Description of Proposed Action and Need

Purpose and Need:

To comply with DOE Executive Order (EO) 14057 Section 102 (ii), the Fermilab Sustainability Department within the Infrastructure Services Division (ISD) is planning for and facilitating the conversion to an electric vehicle (EV) fleet; the Site is anticipating the delivery of 25 plug-in hybrid vehicles and 30 fully electric vehicles in summer of 2024. Additional electric vehicles will be procured each year as part of routine replacements, with the goal of 100% carbon-free vehicle procurement by 2035. Currently, there are only six charging stations across Fermilab, which are not sufficient to handle the planned increase in electric vehicles. To successfully integrate the use of EV throughout the site, additional EV charging stations will be required at multiple locations throughout the Site.

Proposed Action:

This document encompasses the design and full buildout of 55 dual-port EV charging stations at 29 proposed locations throughout the Fermilab site (table 1). The project includes the installation of an EV charger at each location where Fermilab vehicles are planned to be kept. There are currently sixteen locations proposed for installation in 2024. The installation of additional charging stations will occur over the next few years as budgets allows. Any installations after 2024 will require the submittal of an Environmental Review Form (ERF); each additional ERF will reference this document. In addition, charging stations for non-fleet electric vehicles may be installed in the future, which will also require an ERF.

Table 1: Proposed Locations of EV Charging Stations at Fermilab

Proposed Location	FIMS Number	Additional served FIMS Numbers	Proposed Install Year	Charging Level
A-0	217	001, 212, 218	2024	2
MW9 Meson West Lab	420	416	2024	2
Industrial Buildings	801	800, 805, 806	2024	2
Site 38 ISD Operations	922	938	2024	2
Feynman Computing Center	003	n/a	2024	2
User Center	069	044	2024	2
Booster Tower Southeast	208	206, 207	2024	2
Meson Assembly Building	412	n/a	2024	2
NWA Neutrino Lab	614	n/a	2024	2
Site 40 Low Level Rad Waste Handling Building	840	n/a	2024	2
Site 39	926	n/a	2024	2
Sidet Lab A and Lab F	610	600, 608, 612	2024	2
Linac, Cross Gallery, Transfer Gallery	212	001	2024	2
Vehicle Maintenance Remote Parking Lot	930	931	2024	2
Warehouse 2	940	n/a	2024	2
D-0 PPD office	326	n/a	2024	2
D-0 Assembly Building	325	n/a	TBD	2
Fire Station	932	n/a	TBD	2 & 3
Fuel Service Center	929	n/a	TBD	2 & 3
High Intensity Laboratory	506	n/a	TBD	2
Lederman Science Center	005	n/a	TBD	2
MI60 Main Injector	760	n/a	TBD	2
MI8 Main Injector	708	n/a	TBD	2
NML New Muon Lab	700	702	TBD	2
Proton Assembly Building	502	n/a	TBD	2
Site 37 Shop Road & Grounds Front Building	921	n/a	TBD	3
Training Center	522	n/a	TBD	2
Main Control Room in Cross Gallery	212	n/a	TBS	2

All equipment will be designed to accommodate the full build-out of charging stations for the complete EV fleet as proposed, including installation of underground conduit and concrete stands for future charger installation (see design guides in Section VII).

Alternatives Considered:

No Action would fail to accommodate the increase in demand for EV charging and would require vehicle custodians to charge vehicles off-site. This would be an inefficient use of Fermilab resources and could jeopardize Fermilab's ability to meet the requirements of DOE EO 14057 Section 102 (ii).

Alternative locations considered were excluded if planning has not identified that location as receiving an electric vehicle. An ERF will be used to propose additional locations as necessary.

II. Description of the Affected Environment

The installation of EV charging stations will occur within previously disturbed or developed areas (i.e., parking lots) throughout the Site. Specific environmental effects are presented in Section III.

III. Potential Environmental Effects (If the answer to the questions below is "yes", provide comments for each checked item and where clarification is necessary.)

A. Sensitive Resources: Would the proposed action result in changes and/or disturbances to any of the following resources?

- Threatened or endangered species
- Other protected species
- Wetland/Floodplains
- Archaeological or historical resources
- Non-attainment areas

B. Regulated Substances/Activities: Would the proposed action involve any of the following regulated substances or activities?

- Clearing or Excavation
- Demolition or decommissioning
- Asbestos removal
- PCBs
- Chemical use or storage
- Pesticides
- Air emissions
- Liquid effluents
- Underground storage tanks
- Hazardous or other regulated waste (including radioactive or mixed)
- Radioactive exposures or radioactive emissions
- Radioactivation of soil or groundwater

C. Other Relevant Disclosures: Would the proposed action involve any of the following actions/disclosures?

- Threatened violation of ES&H permit requirements
- Siting/construction/major modification of waste recovery or TSD facilities
- Disturbance of pre-existing contamination
- New or modified permits
- Public controversy
- Action/involvement of another federal agency
- Public utilities/services
- Depletion of a non-renewable resource

IV. Comments on checked items in section III.

Clearing and Excavation

There will be minor excavation completed at the proposed EV locations. The total area of excavation will be less than one acre. All excavated material will be properly managed onsite, and material will be recycled as appropriate. Generated material is anticipated to potentially include concrete, asphalt, and soil.

Public utilities/services

This project is for the installation of chargers for electric vehicles and will include installation of associated electric infrastructure.

V. NEPA Recommendation

Fermilab staff has evaluated the proposed action and has determined that the proposed action meets the description found in DOE NEPA Implementation Procedures, 10 CFR 1021, Subpart D, Appendix B5.23, as provided below.

B5.23 Electric vehicle charging stations. The installation, modification, operation, and removal of electric vehicle charging stations, using commercially available technology, within a previously disturbed or developed area. Covered actions are limited to areas where access and parking are in accordance with applicable requirements (such as local land use and zoning requirements) in the proposed project area and would incorporate appropriate control technologies and best management practices.

Fermilab NEPA Program Manager: Samantha Panock Digitally signed by Samantha Panock
Date: 2024.01.12 12:56:30 -06'00' **Samantha Panock** **1/12/24**
Signature and Date _____

VI. DOE/Fermilab Site Office (FSO) NEPA Review

Based upon my review of information conveyed to me and in my possession concerning the proposed action, as NEPA Compliance Officer (as authorized under DOE Policy 451.1), I have determined that the proposed action fits within the specified class of actions, the other regulatory requirements set forth above are met, and the proposed action is hereby categorically excluded from further NEPA review.

FSO NEPA Compliance Officer: Rick Hersemann Digitally signed by RICK HERSEMANN
Date: 2024.01.18 09:12:32 -06'00' **RICK HERSEMANN**
Signature and Date _____

VII. Diagrams

The following documents are attached to this EENF:

1. Map of proposed EV fleet charging locations
2. Charging station design guides

Map of Fleet Vehicle Locations

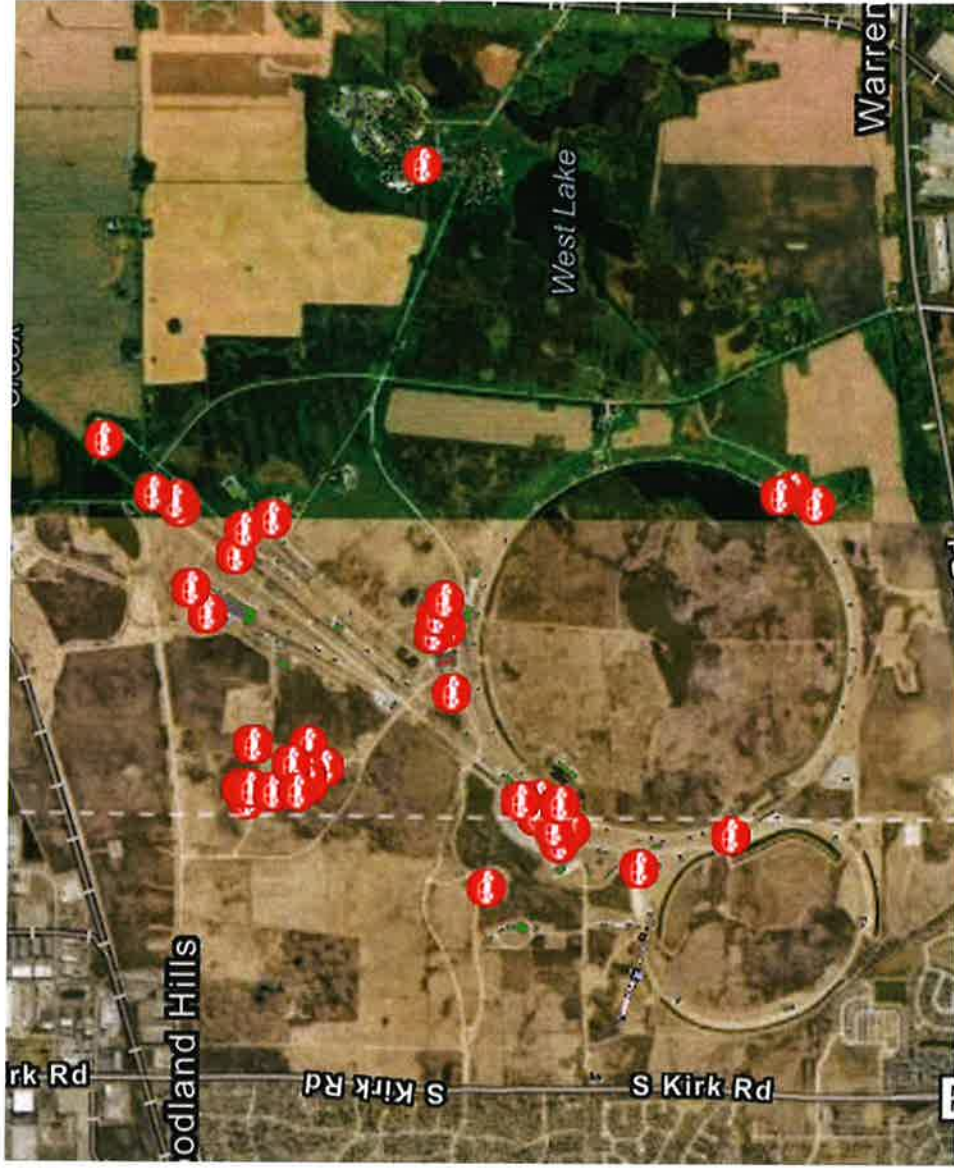



SUBJECT

**SIDEWALK
CIVIL DESIGN GUIDE**

NAME

J. NIEHOFF

DATE

11-26-2012

REVISION DATE

6-13-2023

T/ WALK TO MATCH
FINISHED GRADE

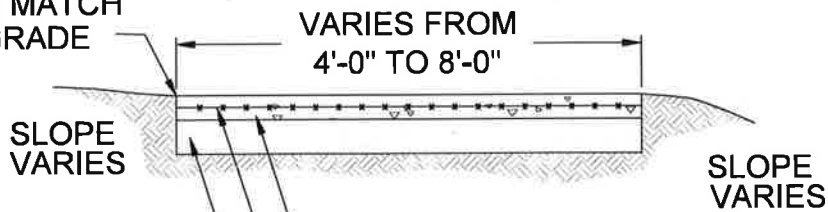

NEW 5" (MIN.) CONCRETE SLAB

6x6 W2.9xW2.9 WELDED WIRE FABRIC
(AT MIDPOINT OF SLAB)

4" MIN. OF COMPACTED CA-6 AGGREGATE BASE

NOTE: PLACE ALL CONCRETE
IN ACCORDANCE WITH
APPLICABLE A.C.I. CODES
AND RECOMMENDATIONS



SUBJECT

**HARDSTAND
CIVIL DESIGN GUIDE**

NAME

J. NIEHOFF

DATE

11-26-2012

REVISION DATE

6-13-2023

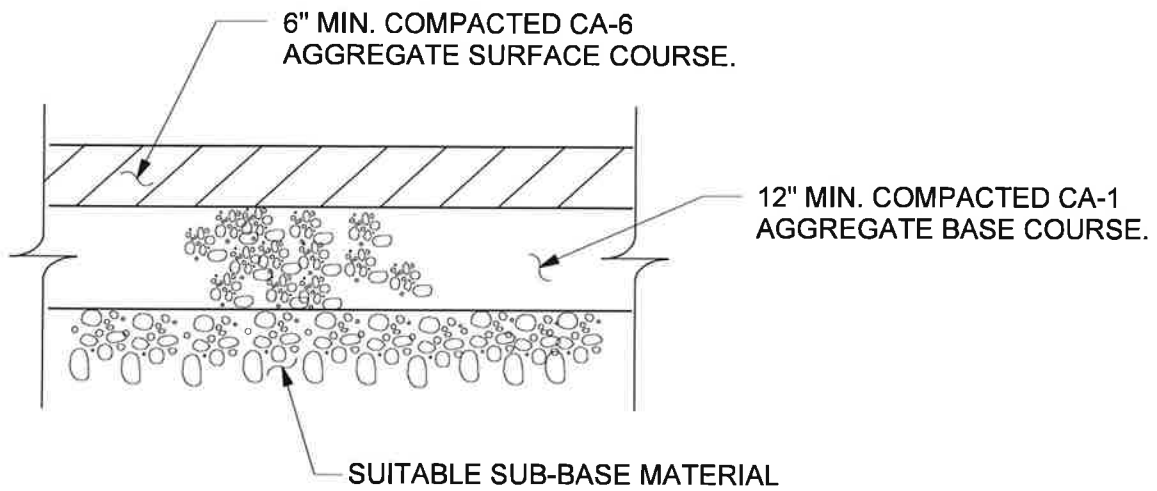



SUBJECT

**BARRIER CURB
CIVIL DESIGN GUIDE**

NAME

J. NIEHOFF

DATE

11-26-2012

REVISION DATE

6-13-2023

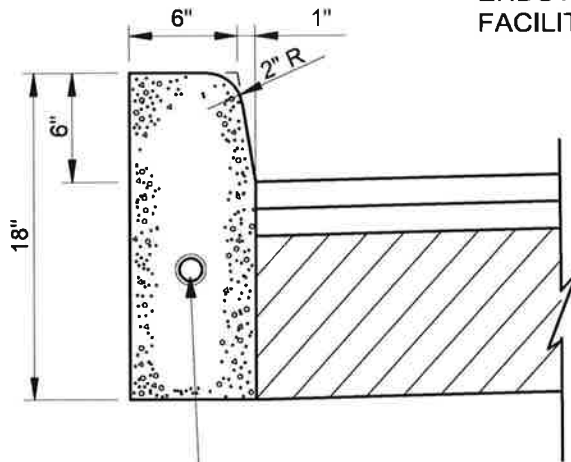

NOTE: TERMINATE CURB
ENDS AT 45° ANGLE TO
FACILITATE SNOW FLOW

1-1/4" DIA. X 18" COATED SMOOTH DOWEL BAR W/FITTED
END CAP AT ALL EXPANSION JOINTS. MINIMUM 1" THICK
EXPANSION JOINTS TO BE PLACED AT ALL SHORT RADIUS
LOCATIONS AND AT CONSTRUCTION JOINTS.

CONTRACTION JOINTS TO BE PLACED BETWEEN EXPANSION
JOINTS SHALL NOT EXCEED 25 FT. SPACING



SUBJECT

**UTILITY PAD - SAMPLE GENERATOR PAD
CIVIL DESIGN GUIDE**

NAME

J. NIEHOFF

DATE

11-26-2012

REVISION DATE

6-13-2023

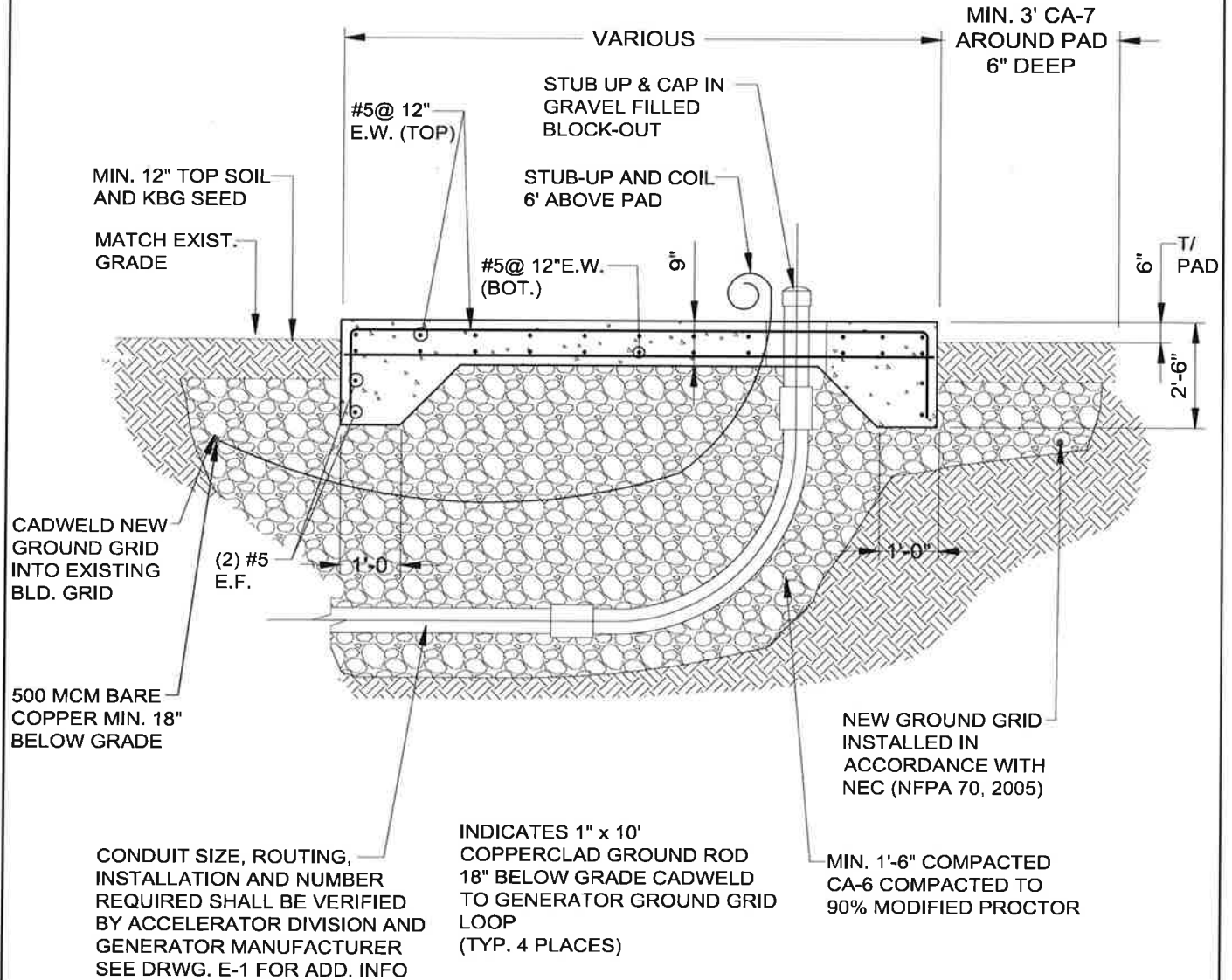



SUBJECT

**GUARDRAIL
CIVIL DESIGN GUIDE**

NAME

R. JOHNSON

DATE

11-26-2012

REVISION DATE

6-21-2023

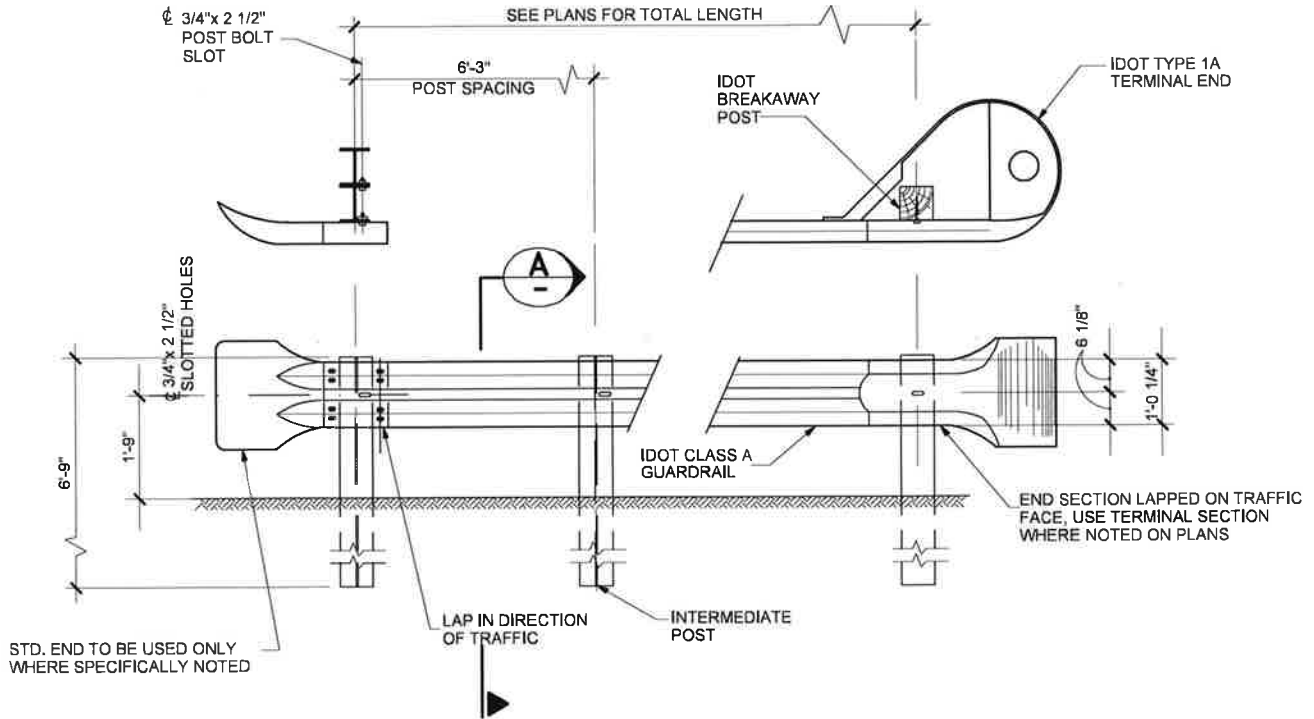

TYPICAL GUARDRAIL

NOT TO SCALE

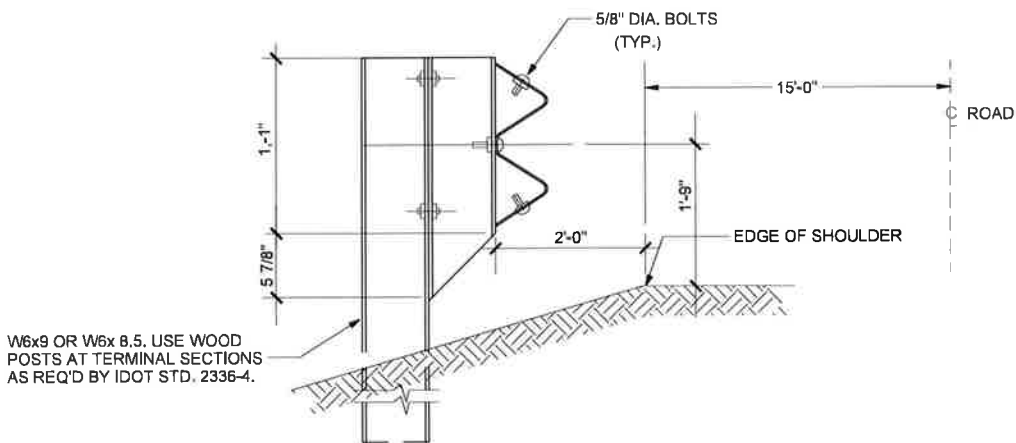

SECTION A

NOT TO SCALE





SUBJECT

**BUMPER POST
CIVIL DESIGN DRAWINGS**

NAME

J. NIEHOFF

DATE

11-26-2012

REVISION DATE

6-14-2023

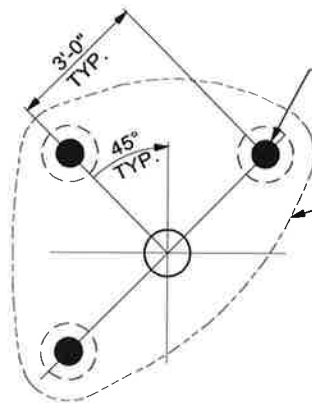

CONCRETE FILLED BUMPER POST AT FIRE HYDRANTS (SEE TYP. BUMPER POST DETAIL)

PROVIDE GRAVEL AROUND VALVE BOX AND HYDRANT , IF BUMPER POSTS ARE PROVIDED GRAVEL AREA TO INCLUDE BUMPER POSTS TO FACILITATE TURF TRIMMING.

PLAN

GUIDANCE: PIVs OR HYDRANTS - WITHIN 30'-0" OF PARKING LOT, MINIMUM 2 BOLLARDS TOWARDS PARKING LOT/ROAD. MOWED/FINE TURF AREA 30'-0" OR MORE FROM ROAD, NO BOLLARDS.

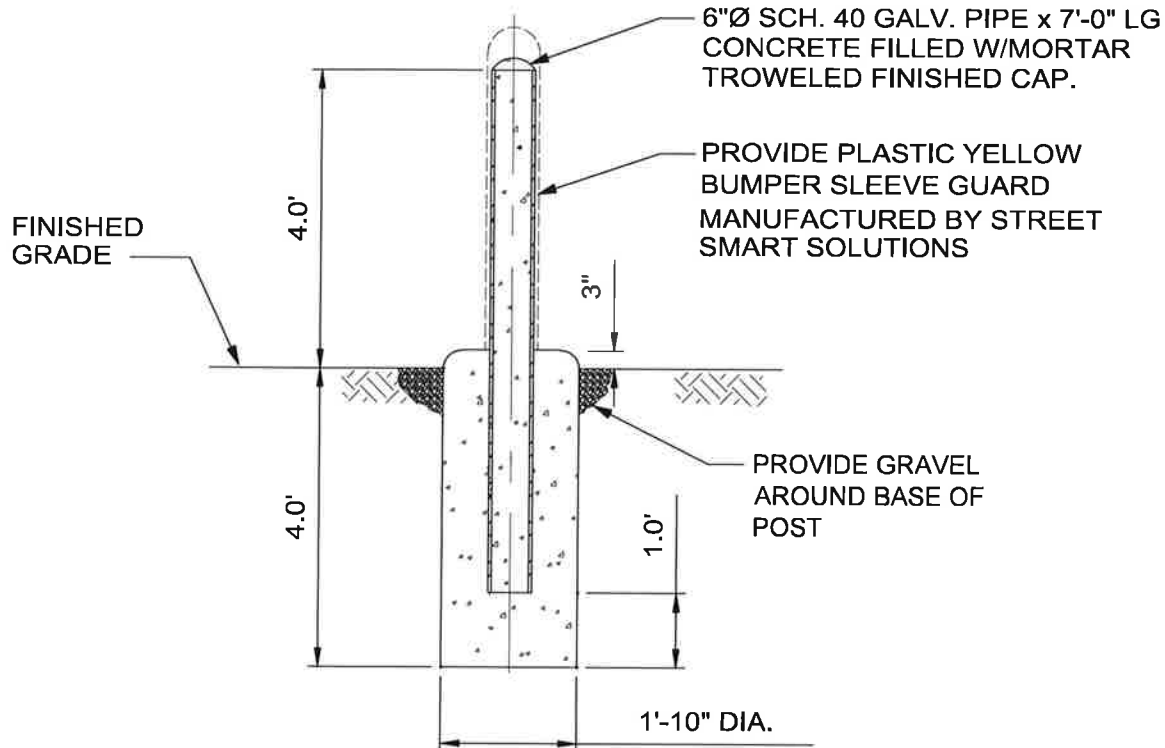

SECTION

NOTE: DESIGNER SHOULD CONSIDER BUMPER POSTS AROUND HVAC OR OTHER SIMILAR EQUIPMENT NEAR TRAFFIC. BUMPER POSTS SHALL BE LOCATED SO AS NOT TO INTERFERE WITH OPERATION AND MAINTENANCE OF EQUIPMENT.

