

Vernet, Jean

same b5

From: Vernet, Jean
Sent: Tuesday, April 17, 2001 10:33 AM
To: Carter, Douglas
Cc: Anderson, Margot
Subject: RE: EPA materials

I'll attempt to add a few of the points to my piece and forward directly to Joe as Margot instructed.

-----Original Message-----

From: Carter, Douglas
Sent: Tuesday, April 17, 2001 10:31 AM
To: Vernet, Jean
Subject: RE: EPA materials

This is what I'm sending to Krip, fyi. Please do not distribute.

Doug

-----Original Message-----

From: Vernet, Jean
Sent: Tuesday, April 17, 2001 9:10 AM
To: Carter, Douglas
Subject: RE: EPA materials
Importance: High

Just got it too. Have asked Lorie if there are some other related pieces we should have.

Would love to share each other's comments.

Jean

-----Original Message-----

From: Carter, Douglas
Sent: Tuesday, April 17, 2001 9:12 AM
To: Vernet, Jean
Subject: FW: EPA materials

Jean -

This is on a fast track. I assume you have it, but if not, you have it now.

Doug

-----Original Message-----

From: Kripowicz, Robert
Sent: Tuesday, April 17, 2001 7:23 AM
To: Carter, Douglas
Subject: FW: EPA materials

Please review the new source review attachment.

Thanks.

-----Original Message-----

From: Kelliher, Joseph
Sent: Monday, April 16, 2001 7:19 PM
To: Anderson, Margot; Kripowicz, Robert
Subject: EPA materials

Please circulate. We will need to turn around quickly.

-----Original Message-----

From: Schmidt.Lorie@epamail.epa.gov%internet
[mailto:Schmidt.Lorie@epamail.epa.gov]
Sent: Monday, April 16, 2001 7:14 PM
To: Kelliher, Joseph
Cc: Symons.Jeremy@epamail.epa.gov%internet;
Moss.Jacob@epamail.epa.gov%internet;
Gibson.Tom@epamail.epa.gov%internet;
Spencer.Susan@epamail.epa.gov%internet
Subject: For Review

For review by USDA and DOE, here is the piece on RFG and boutique fuels:
(See attached file: boutique 4 16 01.wpd)

For review by DOE, here's the additional background piece on NSR:
(See attached file: nsr back 4-16.wpd)

Tracking:	Recipient	Delivery	Read
	Carter, Douglas	Delivered: 4/17/2001 10:33 AM	Read: 4/17/2001 12:49 PM
	Anderson, Margot	Delivered: 4/17/2001 10:33 AM	Read: 4/17/2001 10:47 AM

Vernet, Jean

(b)(5)
or page 2

From: Carter, Douglas
Sent: Tuesday, April 17, 2001 9:12 AM
To: Vernet, Jean
Subject: FW: EPA materials

email (referred)
attached 0-5



boutique 4 16
01.wpd



nsr back 4-16.wpd

Jean -

This is on a fast track. I assume you have it, but if not, you have it now.

[Doug] b5

-----Original Message-----

From: Kripowicz, Robert
Sent: Tuesday, April 17, 2001 7:23 AM
To: Carter, Douglas
Subject: FW: EPA materials

Please review the new source review attachment.
Thanks.

--Original Message-----

From: Kelliher, Joseph
Sent: Monday, April 16, 2001 7:19 PM
To: Anderson, Margot; Kripowicz, Robert
Subject: EPA materials

Please circulate. We will need to turn around quickly.

-----Original Message-----

From: Schmidt.Lorie@epamail.epa.gov%internet
[mailto:Schmidt.Lorie@epamail.epa.gov]
Sent: Monday, April 16, 2001 7:14 PM
To: Kelliher, Joseph
Cc: Symons.Jeremy@epamail.epa.gov%internet;
Moss.Jacob@epamail.epa.gov%internet;
Gibson.Tom@epamail.epa.gov%internet;
Spencer.Susan@epamail.epa.gov%internet
Subject: For Review

For review by USDA and DOE, here is the piece on RFG and boutique fuels:
(See attached file: boutique 4 16 01.wpd)

For review by DOE, here's the additional background piece on NSR:
(See attached file: nsr back 4-16.wpd)

65

The piece provided refers to the latest versions of NEP sections and recommendations I have not seen.

Jean

Jean E. Vernet
Office of Policy, PO-21
U.S. Department of Energy
202.586.4755
fax 202.586.5391

<< File: nsr back 4-16rev redline.wpd >>

29408

Vernet, Jean

From: Vernet, Jean
Sent: Friday, April 06, 2001 8:00 AM
To: Johnson, Nancy
Subject: RE: Request for Input: EPA-Lead Effort on NEP "streamlining permitting" of energy-related facilities

Nancy, Great. Let me know if Jay hasn't provided the fax of the draft. Thanks. - Jean

-----Original Message-----

From: Johnson, Nancy
Sent: Thursday, April 05, 2001 5:35 PM
To: Braitsch, Jay
Cc: Vernet, Jean
Subject: RE: Request for Input: EPA-Lead Effort on NEP "streamlining permitting" of energy-related facilities

This is up our alley. Do you have the fax? Will talk to Jean tomorrow.

Jean: Would be glad to assist. We do lots of stuff in this arena. Need the EPA draft to fully understand how we can assist.

-----Original Message-----

From: Braitsch, Jay
Sent: Thursday, April 05, 2001 5:19 PM
To: Carter, Douglas; Johnson, Nancy
Subject: FW: Request for Input: EPA-Lead Effort on NEP "streamlining permitting" of energy-related facilities
Importance: High

Haven't had a chance to digest this -- anything exciting for you?

-----Original Message-----

From: Vernet, Jean
Sent: Thursday, April 05, 2001 3:09 PM
To: Kelliher, Joseph; Kolevar, Kevin; Haspel, Abe; Braitsch, Jay
Cc: Anderson, Margot
Subject: Request for Input: EPA-Lead Effort on NEP "streamlining permitting" of energy-related facilities
Importance: High

Joe and Kevin.

Abe and Jay.

After you look this over, please provide suggested input to me by COB tomorrow, Friday April 6th. As Margot directed, I will coordinate input to EPA. If this recommendation does go forward to principals for consideration next Wednesday, the earlier we provide input to EPA, the better chance we have of its inclusion.

Vernet, Jean

From: Vernet, Jean
Sent: Sunday, April 08, 2001 12:07 PM
To: McCabe, Michael
Subject: FW: Request for Input: EPA-Lead Effort on NEP "streamlining permitting" of energy-related facilities

Importance: High

Michael,

Will you be providing any input ?

Thanks, Jean

-----Original Message-----

From: Abe Haspel
Sent: Thursday, April 05, 2001 3:45 PM
To: McCabe, Michael
Cc: Vernet, Jean
Subject: Request for Input: EPA-Lead Effort on NEP "streamlining permitting" of energy-related facilities

Please follow up on this. thanks

----- Forwarded by Abe Haspel/EE/DOE on 04/05/2001 03:44 PM -----



in Vernet@HQMAIL on 04/05/2001 03:09:16 PM

From: Abe Haspel/EE/DOE@DOE@HQMAIL, Joseph Kelliher@HQMAIL, Kevin Kolevar@HQMAIL, Jay Braitsch@HQMAIL
cc: Margot Anderson@HQMAIL

Subject: Request for Input: EPA-Lead Effort on NEP "streamlining permitting" of energy-related facilities

Joe and Kevin.

Jean E. Vernet, PO-21
202.586.4755

Abe and Jay,

After you look this over, please provide suggested input to me by COB tomorrow, Friday

April 6th. As Margot directed, I will coordinate input to EPA. If this recommendation does go forward to principals for consideration next Wednesday, the earlier we provide input to EPA, the better chance we have of its inclusion.

Thanks, Jean

Summary Notes: 4/5/01 EPA Meeting on NEP "One-Pager" on Permitting

Short meeting chaired by EPA. Reps of DOI, State, and OMB also attended, together with approx 12 EPA staff (mostly Air, but Fed Activities, Water, and Waste also represented). Beale attended for portion.

all
b5

15
Vernet, Jean

From: Vernet, Jean
Sent: Wednesday, April 04, 2001 9:58 AM
To: Kelliher, Joseph; Anderson, Margot
Cc: Carrier, Paul; Conti, John; Terry, Tracy
Subject: FW: Federal backup generators

Importance: High

Joe,

Paul is sending some info separately, but here's some info on the treatment of federal facilities and the EPA guidance on use of emergency generators.

Jean

Jean E. Vernet
PO-21
202.586.4755



110F~CA1~01.wpd

-----Original Message-----

From: Conti, John
Sent: Wednesday, April 04, 2001 8:55 AM
To: Vernet, Jean
Cc: Carrier, Paul; Anderson, Margot; Kelliher, Joseph
Subject: FW: Federal backup generators
Importance: High

Jean,

I'll assume you have the lead for PO on this issue since I am leaving right now unless you hear differently from Margot. Please provide whatever information you have to Joe by 10:00. Thanks.

-----Original Message-----

From: Kelliher, Joseph
Sent: Wednesday, April 04, 2001 8:50 AM

To: Haspel, Abe; Zimmerman, MaryBeth; Conti, John; Carrier, Paul
Subject: Federal backup generators
Importance: High

135

Tracking:

Recipient	Delivery	Read
Kelliher, Joseph	Delivered: 4/4/2001 9:58 AM	Read: 4/4/2001 10:02 AM
Anderson, Margot	Delivered: 4/4/2001 9:58 AM	Read: 4/4/2001 9:59 AM
Carrier, Paul	Delivered: 4/4/2001 9:58 AM	Read: 4/4/2001 10:05 AM
Conti, John	Delivered: 4/4/2001 9:58 AM	Read: 4/4/2001 9:32 PM
Terry, Tracy	Delivered: 4/4/2001 9:58 AM	Read: 4/4/2001 10:13 AM

4/5/2001

Vernet, Jean

From: Vernet, Jean
Sent: Wednesday, April 04, 2001 9:52 AM
To: Anderson, Margot
Subject: RE: Federal backup generators

Both Paul and me, independently given time allowed.

-----Original Message-----

From: Anderson, Margot
Sent: Wednesday, April 04, 2001 9:21 AM
To: Vernet, Jean
Cc: Carrier, Paul
Subject: RE: Federal backup generators

Who is working on this for Joe?

-----Original Message-----

From: Conti, John
Sent: Wednesday, April 04, 2001 8:55 AM
To: Vernet, Jean
Cc: Carrier, Paul; Anderson, Margot; Kelliher, Joseph
Subject: FW: Federal backup generators
Importance: High

Jean,

I'll assume you have the lead for PO on this issue since I am leaving right now unless you hear differently from Margot. Please provide whatever information you have to Joe by 10:00. Thanks.

-----Original Message-----

From: Kelliher, Joseph
Sent: Wednesday, April 04, 2001 8:50 AM
To: Haspel, Abe; Zimmerman, MaryBeth; Conti, John; Carrier, Paul
Subject: Federal backup generators
Importance: High

b5
[handwritten mark]

Tracking:	Recipient	Delivery	read
	Anderson, Margot	Delivered: 4/4/2001 9:52 AM	Read: 4/4/2001 9:59 AM

Vernet, Jean

From: Vernet, Jean
Sent: Wednesday, April 04, 2001 12:15 PM
To: Terry, Tracy
Subject: FW: Federal backup generators

-----Original Message-----

From: Carrier, Paul
Sent: Wednesday, April 04, 2001 9:31 AM
To: Kelliher, Joseph; Haspel, Abe; Zimmerman, MaryBeth; Conti, John
Cc: Vernet, Jean; Anderson, Margot
Subject: RE: Federal backup generators

Joe,

Paul

-----Original Message-----

From: Kelliher, Joseph
Sent: Wednesday, April 04, 2001 8:50 AM
To: Haspel, Abe; Zimmerman, MaryBeth; Conti, John; Carrier, Paul
Subject: Federal backup generators
Importance: High

Tracking:

Recipient
Terry, Tracy

Delivery
Delivered: 4/4/2001 12:15 PM

Read
Read: 4/4/2001 3:57 PM

B5som

Vernet, Jean

From: Schoeberlein, Dave
Sent: Wednesday, March 07, 2001 5:14 PM
To: Vernet, Jean
Cc: Terry, Tracy
Subject: Muti-pollutant paper

.Jean

| B5

Dave S.



Multi for Margo.doc

Vernet, Jean

m: Kelliher, Joseph
sent: Tuesday, April 17, 2001 1:01 PM
To: Vernet, Jean
Subject: RE: comments/revisions to EPA NSR background document

Importance: High

Jean: [

] b5

—Original Message—

From: Vernet, Jean
Sent: Tuesday, April 17, 2001 10:57 AM
To: Kelliher, Joseph
Cc: Anderson, Margot; Conti, John; Carter, Douglas
Subject: comments/revisions to EPA NSR background document
Importance: High

Joe,

Attached is a redline/strikeout version of the edited piece. The version attempts to address some [

b5

Jean

Jean E. Vernet
Office of Policy, PO-21
U.S. Department of Energy
202.586.4755
fax 202.586.5391

<< File: nsr back 4-16rev redline.wpd >>

Vernet, Jean

b5

From: Conti, John
Sent: Monday, April 02, 2001 1:15 PM
To: Vernet, Jean; Terry, Tracy
Subject: RE: Final 1-pager on 3-pollutant strategy

As you know, I wasn't around on Friday when you were working on this. I don't know if Margot received a copy. I never recieved anything from Colivar (sp?) or Kelliher.

-----Original Message-----

From: Vernet, Jean
Sent: Monday, April 02, 2001 9:20 AM
To: Terry, Tracy; Conti, John
Subject: RE: Final 1-pager on 3-pollutant strategy

Tracy/John.

b5

was this sent to Margot? Did Kelliher & Kelivar (sp?) ever send us or them anything?

Jean

-----Original Message-----

From: Terry, Tracy
Sent: Friday, March 30, 2001 4:27 PM
To: Vernet, Jean; Conti, John
Subject: FW: Final 1-pager on 3-pollutant strategy

Incorporates DOE comments.

Jeremy Symons
EPA, Office of Air and Radiation
(202) 564-9301
Fax: (202) 501-0394

B5gmm

Vernet, Jean

From: Schoeberlein, Dave
Sent: Wednesday, March 07, 2001 5:14 PM
To: Vernet, Jean
Cc: Terry, Tracy
Subject: Muti-pollutant paper

Jean,

25

Dave S.



Multi for Margo.doc

29431

Vernet, Jean

65

From: Conti, John
Sent: Monday, April 02, 2001 1:15 PM
To: Vernet, Jean; Terry, Tracy
Subject: RE: Final 1-pager on 3-pollutant strategy

As you know, I wasn't around on Friday when you were working on this. I don't know if Margot received a copy. I never recieved anything from Colivar (sp?) or Kelliher.

-----Original Message-----

From: Vernet, Jean
Sent: Monday, April 02, 2001 9:20 AM
To: Terry, Tracy; Conti, John
Subject: RE: Final 1-pager on 3-pollutant strategy

Tracy/John,

B.S

Was this sent to Margot? Did Kelliher & Kelivar (sp?) ever send us or them anything?

Jean

-----Original Message-----

From: Terry, Tracy
Sent: Friday, March 30, 2001 4:27 PM
To: Vernet, Jean; Conti, John
Subject: FW: Final 1-pager on 3-pollutant strategy

Incorporates DOE comments.

Jeremy Symons
EPA, Office of Air and Radiation
(202) 564-9301
Fax: (202) 501-0394

Received Date: 2/5/01

INVITATIONS AND REQUESTS FOR THE SECRETARY
OFFICE OF SCHEDULING AND ADVANCE

- ACCEPT
- DECLINE
- PENDING
- SURROGATE

EVENT DATE: 2/9/01

LEAD STAFF:

LOCATION OF EVENT: Washington, DC

ATTENDING STAFF:

ORGANIZATION: NATURAL GAS SUPPLY ASSOCIATION

EVENT DESCRIPTION: John Sharp, Executive Vice President and Council, requests meeting for Don Niemiec, President of Union Pacific Resources, to discuss energy policy as it relates to natural gas and also to introduce Mr. Niemiec, Tues. Feb. 6 - Fri. Feb. 9. NOTE: Stated that Mr. Niemiec is a friend of Sec. Dan Evans.

CATEGORY: Meeting

AUDIENCE: Don Niemiec, President of Union Pacific Resources

PARTICIPANTS: Back-to-back meetings from 9:50 a.m. - 7:00 p.m.

MEDIA COVERAGE:

PROGRAM OFFICE:

RECOMMENDATION:

STATUS: Decline

VET WITH

hbs

29433

Received Date: 1/30/01

**OPEN INVITATIONS AND REQUESTS FOR THE SECRETARY
OFFICE OF SCHEDULING AND ADVANCE**

- ACCEPT
- DECLINE
- PENDING
- SURROGATE

EVENT DATE: Open

LEAD STAFF:

LOCATION OF EVENT: Washington, DC

ATTENDING STAFF:

ORGANIZATION: CONGRESSWOMAN SHELLEY CAPITO

EVENT DESCRIPTION: Congresswoman Shelley Moore Capito, M.C. requests a meeting with S-1 in DC to discuss President Bush's energy policy goals, especially as they relate to the use of coal in clean burning coal fired power plants.

CATEGORY: Meeting

AUDIENCE:

MEDIA COVERAGE:

PROGRAM OFFICE:

RECOMMENDATION:

STATUS: Decline

VET WITH:

165

29434

Received Date: 2/12/01

**INVITATIONS AND REQUESTS FOR THE SECRETARY
OFFICE OF SCHEDULING AND ADVANCE**

- ACCEPT
- DECLINE
- PENDING
- SURROGATE

EVENT DATE: 3/5/01

LEAD STAFF:

LOCATION OF EVENT: Washington, DC

ATTENDING STAFF:

ORGANIZATION: NEBRASKA FARM BUREAU FEDERATION/BOARD OF DIRECTORS

EVENT DESCRIPTION: The Board of Directors of the Nebraska Farm Bureau Federation would like to meet with S-1 to discuss U.S. energy policy and current problems in agriculture associated with high energy costs. The date they would like to meet is Tuesday, March 6th. They would like to meet with other senior officials as well.

CATEGORY: Meeting

AUDIENCE: Not yet available

MEDIA COVERAGE:

PROGRAM OFFICE:

RECOMMENDATION: [

STATUS: Decline

VET WITH: [

65
] 65

] 65

29435

Received Date: 2/15/01

**OPEN INVITATIONS AND REQUESTS FOR THE SECRETARY
OFFICE OF SCHEDULING AND ADVANCE**

- ACCEPT
- DECLINE
- PENDING
- SURROGATE

EVENT DATE: Open

LEAD STAFF:

LOCATION OF EVENT: Washington, DC

ATTENDING STAFF:

ORGANIZATION: NUCLEAR ENERGY INSTITUTE

EVENT DESCRIPTION: Joe Colvin, President and CEO, would like to meet with S-1 to discuss nuclear energy's role in national energy policy. He will be accompanied by several CEO's of major utilities who are members of NEI.

CATEGORY: Meeting

AUDIENCE: Joe F. Colvin, President and CEO

MEDIA COVERAGE:

PROGRAM OFFICE:

RECOMMENDATION: [] b5

STATUS: Accept

VET WITH: [] b5

29436

Received Date: 2/21/01

**INVITATIONS AND REQUESTS FOR THE SECRETARY
OFFICE OF SCHEDULING AND ADVANCE**

- ACCEPT
- DECLINE
- PENDING
- SURROGATE

EVENT DATE: 3/28/01

LOCATION OF EVENT: Washington, DC

ORGANIZATION: COPELAND, LOWERY AND JACQUEZ

EVENT DESCRIPTION: Former Representative Bill Lowery, requests a meeting with S-1 and a small group of Large Public Power Council CEOs and their representatives to discuss energy policy and the private use issue. NOTE: Wanted to meet on 3/6. S-1 requested later date. Will 3/28 be ok with S-1?)

CATEGORY: Meeting

AUDIENCE: Walt Bussell's Managing Dir., Jacksonville Electric Authority; Bob Johnston, President/CEO, Municipal Electric Authority of G

MEDIA COVERAGE:

PROGRAM OFFICE:

RECOMMENDATION:

STATUS: Accept

VET WITH: [Handwritten initials]

[Handwritten: J65]

29487

[Handwritten: J65]

Received Date: 3/7/01

**INVITATIONS AND REQUESTS FOR THE SECRETARY
OFFICE OF SCHEDULING AND ADVANCE**

- ACCEPT
- DECLINE
- PENDING
- SURROGATE

EVENT DATE: 6/22/01

EVENT DATES: 6/21/01

6/23/01

LEAD STAFF:

LOCATION OF EVENT: Keystone, CO

ATTENDING STAFF:

ORGANIZATION: INDEPENDENT PETROLEUM ASSOCIATION OF AMERICA

EVENT DESCRIPTION: Barry Russell, President, invites S-1 to speak at their Mid-Year Meeting, Friday, June 22 - Saturday, June 23 in Keystone, CO. Wishes S-1 to discuss the President's energy task force.

CATEGORY: Speech

AUDIENCE: Approximately 500 executive level independent oil & natural gas producers

MEDIA COVERAGE:

PROGRAM OFFICE:

RECOMMENDATION:

STATUS: Accept

VET WITH: [handwritten mark]

29488

[handwritten mark]

[handwritten mark]

Received Date: 3/12/01

**INVITATIONS AND REQUESTS FOR THE SECRETARY
OFFICE OF SCHEDULING AND ADVANCE**

- ACCEPT
- DECLINE
- PENDING
- SURROGATE

EVENT DATE: 4/5/01

LEAD STAFF:

LOCATION OF EVENT: Washington, DC

ATTENDING STAFF:

ORGANIZATION: NATIONAL PETROLEUM COUNCIL (EL PASO ENERGY CORPORATION)

EVENT DESCRIPTION: Lori E. Laudien, Director, Federal Government Affairs, is following up on a conversation S-1 had with Mr. William A. Wise, Chairman, President and CEO of El Paso Corporation, in February about meeting with members of the National Petroleum Council to discuss energy supply issues with S-1 generally and, in particular, the energy initiatives that S-1 would like to pursue. (NOTE: we have a request for a meeting with S-1 from Archie W. Dunham).

CATEGORY: Meeting

AUDIENCE: Members of the National Petroleum Council -- Archie W. Dunham, Chairman, President and CEO of Conoco and Chair of NPC,

MEDIA COVERAGE:

PROGRAM OFFICE:

RECOMMENDATION: [

STATUS: Accept

VET WITH: [

J65

J65

29439

Received Date:

**INVITATIONS AND REQUESTS FOR THE SECRETARY
OFFICE OF SCHEDULING AND ADVANCE**

- ACCEPT
- DECLINE
- PENDING
- SURROGATE

EVENT DATE: 3/27/01

LEAD STAFF:

LOCATION OF EVENT: Washington, DC

ATTENDING STAFF:

ORGANIZATION: THE AMERICAN COAL COMPANY

EVENT DESCRIPTION: Robert E. Murray, Director, requests to discuss the National Energy Policy. Mr. Murray stated that he understands S-1 is currently meeting with Senators regarding the National Energy Policy, and he believes his input would be very valuable to S-1 at this time.

CATEGORY: Meeting

AUDIENCE: Robert E. Murray, Director

MEDIA COVERAGE:

PROGRAM OFFICE:

RECOMMENDATION:

] b5

STATUS: Accept

VET WITH:

29440

Received Date: 3/13/01

**INVITATIONS AND REQUESTS FOR THE SECRETARY
OFFICE OF SCHEDULING AND ADVANCE**

ACCEPT
 DECLINE
 PENDING
 SURROGATE

EVENT DATE: 3/28/01

EVENT DATES: 3/28/01

LEAD STAFF:

LOCATION OF EVENT: Washington, DC

ATTENDING STAFF:

ORGANIZATION: NATIONAL MINING ASSOCIATION

EVENT DESCRIPTION: Jack Gerard, President and CEO of the National Mining Association, invites ESA to address their Board of Directors on Wednesday, March 28th in DC. They would be interested in hearing ESA's thoughts on the VP's Task Force, where ESA sees energy policy going and what they can do to help. NOTE: BOB MURRAY WILL BE ATTENDING THIS EVENT.

CATEGORY: Speech

AUDIENCE: Expecting over 60 CEO's from the coal and hardrock mining companies along with manufacturers and suppliers

MEDIA COVERAGE:

PROGRAM OFFICE:

RECOMMENDATION:

STATUS: Decline

VET WITH: []

765

29441

Received Date: 2/5/01

INVITATIONS AND REQUESTS FOR THE SECRETARY
OFFICE OF SCHEDULING AND ADVANCE

ACCEPT
 DECLINE
 PENDING
 SURROGATE

EVENT DATE: 3/19/01

LEAD STAFF:

LOCATION OF EVENT: Washington, DC

ATTENDING STAFF:

ORGANIZATION: U.S CHAMBER OF COMMERCE

EVENT DESCRIPTION: Joesph Davis forward invitation from Williams L. Kovacs of the Chamber, inviting S-1 to deliver the keynote address at their National Energy Summit. Wishes S-1 to discuss energy policy, California, etc, Mon. March 19 - Tues. 20, in DC,

CATEGORY: **Speech**

AUDIENCE: Expecting top players in the energy sector

PARTICIPANTS: Feb. 9, accept per Majida.

MEDIA COVERAGE:

PROGRAM OFFICE:

RECOMMENDATION:

STATUS: Accept \ 2/12/01

VET WITH: *[Signature]*

J 65

29442

Received Date: 3/20/01

INVITATIONS AND REQUESTS FOR THE SECRETARY
OFFICE OF SCHEDULING AND ADVANCE

- ACCEPT
- DECLINE
- PENDING
- SURROGATE

EVENT DATE: 3/21/01

LEAD STAFF:

LOCATION OF EVENT: Washington, DC

ATTENDING STAFF:

ORGANIZATION: NATIONAL ASSOCIATION OF STATE ENERGY OFFICIALS (NASEO)

EVENT DESCRIPTION: Jeffrey Genzer, Counsel, requests a meeting with S-1 or a senior staff member of his staff on Wednesday, March 21, 2001. Ten state energy directors from the U.S. will be meeting with the White House Energy Policy Development Group and they would like to discuss the energy crisis with DOE officials as well.

CATEGORY: Meeting

AUDIENCE: Ten State Energy Directors from the U.S.

MEDIA COVERAGE:

PROGRAM OFFICE:

RECOMMENDATION: [

7 b5

STATUS: Decline

VET WITH:

29443

Received Date: 4/5/01

INVITATIONS AND REQUESTS FOR THE SECRETARY
OFFICE OF SCHEDULING AND ADVANCE

- ACCEPT
- DECLINE
- PENDING
- SURROGATE

01/19/01
[Handwritten signature]

EVENT DATE: 4/10/01

EVENT DATES: 4/10/01

4/11/01

LEAD STAFF:

LOCATION OF EVENT: Washington, DC

ATTENDING STAFF:

ORGANIZATION: ULTRAMA DIAMOND SHAMROCK

EVENT DESCRIPTION: Jean Gaulin, Chairman and CEO, requests a meeting a meeting with S-1 to discuss the national energy policy. The strategic importance of our domestic refining and marketing infrastructure is one of Mr. Gaulin's concerns. Wishes to meet Tuesday April 10 - Wednesday, April 11 or Tuesday, May 8 - Wednesday, May 9, in DC. Stated that Ultrama Diamond Shamrock is on the country's largest independent marketing and refining companies.

CATEGORY: Meeting

AUDIENCE: Jean Gaulin, Chairman and CEO

MEDIA COVERAGE:

PROGRAM OFFICE:

RECOMMENDATION: [

] b5

STATUS: Decline

VET WITH: [

] b5

29444

Received Date: 5/17/01

INVITATIONS AND REQUESTS FOR THE SECRETARY
OFFICE OF SCHEDULING AND ADVANCE

- ACCEPT
- DECLINE
- PENDING
- SURROGATE

EVENT DATE: 5/22/01

LEAD STAFF:

LOCATION OF EVENT: Washington, DC

ATTENDING STAFF:

ORGANIZATION: U.S. CONGRESS/ CONGRESSMAN J.D. HAYWORTH

EVENT DESCRIPTION: Congressman J.D. Hayworth requests S-1 to be his guest on the Congressman's monthly TV "Report to the People", on Tuesday, May 22nd at 3:00 p.m. in the House Recording Studio in the Rayburn House Office Building. Topic would be the Administration's energy plan.

CATEGORY: Other

AUDIENCE: The Secretary

MEDIA COVERAGE:

PROGRAM OFFICE:

RECOMMENDATION:

165

STATUS: Decline

VET WITH:

165

29445

Received Date: 5/2/01

**INVITATIONS AND REQUESTS FOR THE SECRETARY
OFFICE OF SCHEDULING AND ADVANCE**

- ACCEPT
- DECLINE
- PENDING
- SURROGATE

EVENT DATE: 5/23/01

EVENT DATES: 5/23/01 5/26/01

LEAD STAFF:

LOCATION OF EVENT: Kona, HI

ATTENDING STAFF:

ORGANIZATION: NATIONAL ASSOCIATION OF COUNTIES (NACO)

EVENT DESCRIPTION: Jane Hague, NACO's President and George Enneking, Western Interstate Region President, invites S-1 to address the joint meeting of the Public Lands Steering Committee and the Environment, Energy and Land Use Steering Committee at their Western Interstate Region Conference in Kona, Hawaii on Wednesday, May 23. Representatives from the U.S. Energy Association and the Natural Resources Defense Council will also make presentations regarding their recommendations on energy policy.

CATEGORY: Speech

AUDIENCE: Expecting 75 association leaders

MEDIA COVERAGE:

PROGRAM OFFICE:

RECOMMENDATION:

STATUS: Decline

VET WITH: []

J b5

29446

Received Date: 1/31/01

**INVITATIONS AND REQUESTS FOR THE SECRETARY
OFFICE OF SCHEDULING AND ADVANCE**

- ACCEPT
- DECLINE
- PENDING
- SURROGATE

EVENT DATE: 3/20/01

LEAD STAFF:

LOCATION OF EVENT: Washington, DC

ATTENDING STAFF:

ORGANIZATION: PRUDENTIAL

EVENT DESCRIPTION: Mr. Lucier requests S-1 to address a conference of institutional investors from Wall Street and around the country on goals and objectives of the Bush Administration's new national energy security policy in DC on March 20, 2001.

CATEGORY: Speech

AUDIENCE:

MEDIA COVERAGE:

PROGRAM OFFICE:

RECOMMENDATION:

STATUS: Decline \ 2/6/01

VET WITH:

2947

Received Date: 3/1/01

**INVITATIONS AND REQUESTS FOR THE SECRETARY
OFFICE OF SCHEDULING AND ADVANCE**

- ACCEPT
- DECLINE
- PENDING
- SURROGATE

EVENT DATE: 4/3/01

EVENT DATES: 4/3/01

4/4/01

LEAD STAFF:

LOCATION OF EVENT: Washington, DC

ATTENDING STAFF:

ORGANIZATION: WILEY, REIN & FIELDING

EVENT DESCRIPTION: Richard C. Green, Chairman and CEO, UtiliCorp, requests a meeting with S-1 on either Tuesday, March 13 or Wednesday March 14, 2001 in DC. UtiliCorp United is a gas and electric utility and national marketer that has been involved in advancing competitive markets here in the U.S. and abroad. Mr. Green would like to discuss wholesale electricity issues and the Administration's National Energy Policy recommendations.

✓
L

J

b5

CATEGORY: Meeting

AUDIENCE: Richard C. Green, Chairman and CEO

MEDIA COVERAGE:

PROGRAM OFFICE:

RECOMMENDATION:

L

STATUS: Accept

VET WITH:

J b5

29448

National Indian Business Association

725 Second Street, N.E., Washington, D.C. 20002

488113

May 23, 2001

The Honorable George W. Bush
President of the United States
1600 Pennsylvania Ave., NW
Washington, DC 20500

Dear President Bush:

At its 9th Annual Conference and Trade Show, April 29 - May 2, 2001, in Albuquerque, NM, the National Indian Business Association's Board of Directors adopted the attached National Energy Policy Resolution. This Resolution calls on Congress and the new Administration to enact legislation in the 107th Congress establishing a domestic energy policy that will assure adequate domestic oil and gas supplies, infrastructure, and an adequate electricity generation and expanded electricity transmission system.

As an Association representing over 24,000 Native American and Alaska Native businesses of all sizes, NIBA is focused on addressing those issues that could significantly impact economic growth and development for Native Americans, both on and off Reservations. Our current domestic energy situation and its potential impact on tribal communities is one such issue.

In addressing this important policy issue, NIBA urges that the Congress be sensitive to the concerns of Native Americans. Furthermore, we urge the Administration to take steps to exist for increased energy production from abundant and the prospects for economic

ers of
lution.
ties that
are

On behalf of the NIBA Board of Directors
of the National Indian Business Association
of the Native American and Alaska Native
needs.

tion
tion
gully

With warm regards, I am

Sincerely,

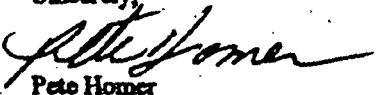

Pete Homer
President/CEO

(b)(5)

Attach.

niba National Indian Business Association

725 Second Street, N.E., Washington, D.C. 20002

NATIONAL INDIAN BUSINESS ASSOCIATION

RESOLUTION NO. 01 - 1005

NATIONAL ENERGY POLICY

WHEREAS, while the United States is rich in natural resources and advanced energy technologies, the current condition of our energy industry is placing Tribal, State and local energy economies at risk and poses serious challenges for our Nation; and

WHEREAS, escalating oil and gas prices, a growing dependence on foreign oil, a constrained electric power grid and other factors are all signs that our Nation's energy situation requires immediate attention; and

WHEREAS, Tribal, State and local communities and energy providers have a common interest in ensuring the availability and reliability to consumers of low-cost electric power generation and supply; and

WHEREAS, market-based solutions are needed to assure adequate and diverse domestic energy supplies and infrastructure, encourage development of advanced technologies, improve energy efficiency and meet tribal, state and local community and consumer needs for affordable and reliable energy, while ensuring the quality of the environment.

NOWHEREFORE, BE IT RESOLVED THAT THE NATIONAL INDIAN BUSINESS ASSOCIATION, ASSEMBLED IN ALBUQUERQUE, April 29 - May 2, 2001 dedicates itself to educating its members, constituents and others on the need for a sound, rational domestic energy policy; and

BE IT FURTHER RESOLVED, that on behalf of its Members, the National Indian Business Association calls on Congress to enact legislation in the 107th Congress establishing a domestic energy policy that will assure adequate domestic oil and gas supplies and infrastructure, adequate electricity generation and an expanded electricity transmission system; and

BE IT FURTHER RESOLVED, that such domestic energy policy, at a minimum, further address tribal community needs for energy assistance to low-income households, development of alternative energy sources, improvements in energy efficiency, appropriate consideration of the energy impacts of regulatory policies and the role of other important energy security options, including clean coal technologies, hydropower and nuclear energy; and

BE IT FINALLY RESOLVED, that this Resolution be dispatched to the President of the United States, the Vice President of the United States, Members of Congress, Governors and other local officials as are appropriate.

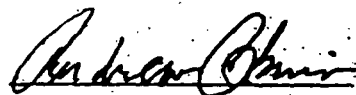

DATE: 4/29/2001

Tel. (202) 547-0580 Fax (202) 547-0589 Email: niba1@msn.com

6 Television: A medium so-called because it is neither rare nor well done.

Ernie Kovacs, *Fingers' Book of Quotes*.

VIEWPOINT

SUNDAY January 7, 2001

ANG NEWSPAPERS

Power problems: Their geneses, reviving nuclear solutions

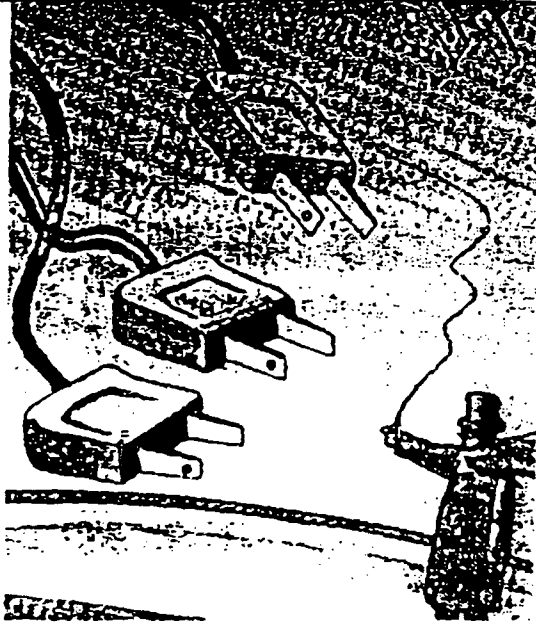

WHY is California now suffering from a lack of affordable electricity? The answer is that California and the nation have not looked responsibly to the future.

In the late 1960s and early 70s, the United States was doubling its electricity use every 10 years. To meet coming needs, utilities were placing major orders for new generating plants. In 1973, the situation changed. The Arab oil boycott and the resulting higher energy costs slowed the growth of electricity use to a doubling in 35 years. As a result, the new plants ordered before 1973 that were subsequently built led to a surplus of electrical supply.

That nationwide surplus, which is now gone, is what California officials were counting on when deregulation was approved in 1996 — a robust, competitive market of wholesale electrical supply from generating companies outside the state. That expectation failed. Why?

Before 1973, the Sierra Club supported nuclear power. Since then, the influential "environmental" organizations have opposed oil, gas, coal and nuclear plants, as well as dams, and even geo-

**BERTRAM WOLFE
and CHAUNCEY STARR**

thermal plants. They argue for solar and wind power, which on a large scale are impractical because of their immense land use and their intermittent availability; indeed, on such a scale they are environmentally detrimental. However, with a surplus of energy supply, it didn't matter.

But the electrical surplus has vanished. In the United States we now need new energy capacity to meet our present and future needs. On a world basis, population in the next 50 years is projected to increase from 6 billion to 10 billion. If the average per-person energy use reaches only one-third of that in the United States today, world energy use will triple. Thus, we now face serious near-term national and coming world energy problems.

In this country we must decide how to meet our energy needs. The Energy Information Administration projects a continued U.S. increase of electricity needs of 40 percent in the next 20 years, and the needed replacement of 25 percent of our current capacity.

There are problems that must be addressed. The price of natural gas has quadrupled in the past year. New gas-fired electricity plants, which were the least expensive source of electricity, are now the most expensive. Natural gas supply will remain tight for the foreseeable future, with accompanying price volatility depending on weather and import availability from Canada and Mexico.

Oil is subject to serious overseas political problems and costs that have gone up and down. Coal, which is among the most plentiful and least costly energy sources, has environmental problems: large emissions of CO₂ and other pollutants, including small particles.

Nuclear energy, which has no significant emissions, can also be among the low-cost energy sources, but it has political barriers to overcome. The 103 existing nuclear plants (ordered before 1973) remain a vital, safe, electricity source in California and in the United States. But since 1973 it has taken an uneconomic 10 to 20 years to build the previously ordered nuclear plants in this country, whereas U.S. companies build nuclear plants abroad (and used to build them here) economically in four or five years. Similarly, anti-nuclear forces have unnecessarily delayed the construction of repositories for nuclear wastes.

The electricity trap in which California now finds itself is a consequence of the national trends coming together this winter. Weather has increased demand in the Western United States, so California cannot depend on low-cost electricity purchases from neighboring states. The political response has so far been Band-Aid fixes, which do not tackle the root issue of making California a friendly state for long-term investment by electricity generators.

The recent electricity problems in California make it clear that we must take action to prevent future energy disasters. In the next few years, our only means to provide the needed electricity is with an expansion of gas- and/or coal-powered plants, with their financial and environmental problems. We should demonstrate now that nuclear plants can be built here as efficiently as they can be built abroad and move to get our waste repositories moving. We need government commitment and action to ensure that we can meet our near-term and long-term energy needs in California and nationally.

The one available solution is a major increase in the utilization of nuclear energy. Nuclear energy can provide an essentially unlimited supply of energy economically. Anti-nuclear activists frighten the public about nuclear wastes thousands of years out. But the real concerns are fossil fuel environmental impacts and the lack of energy in the coming decades when oil and gas supplies are exhausted and, in the following century, when economic coal supplies are depleted. The near-term expansion of nuclear energy would allow us to mitigate global warming and to lengthen the availability of specially needed fossil fuels. Although long-term nuclear wastes can be safely accommodated, advanced nuclear plant designs will allow us to modify the nuclear wastes so that they lose their radioactivity to just a few hundred years.

Today, we are having very disturbing but relatively mild energy problems due to our lack of preparation. We must work to solve this near-term problem. But we should also not wait for the future national and world energy disasters to occur before we act to mitigate and hopefully eliminate them.

Bertram Wolfe is an independent consultant and a fellow and past president of the American Nuclear Society. Chauncey Starr is president emeritus of the Electric Power Research Institute.

NEAR-TERM DEMONSTRATION OF BENIGN, SUSTAINABLE, NUCLEAR POWER

Carl E. Walter*

Nuclear power reactors have been studied, researched, developed, constructed, demonstrated, deployed, operated, reviewed, discussed, praised and maligned in the United States for over half a century. These activities now transcend our national borders and nuclear power reactors are in commercial use by many nations. Throughout the world, many have been built, some have been shut down, and new ones are coming on line. Almost one-fifth of the world's electricity in 1997 was produced from these reactors. Nuclear power is no longer an unknown new technology.

A large increase in world electricity demand is projected for the coming century. In lieu of endless research programs on "new" concepts, it is now time to proceed vigorously with widespread deployment of the best nuclear power option for which most parameters are already established. Here, we develop an aggressive approach for initiating the deployment of such a system— with the potential to produce over half of the world's electricity by mid-century, and to continue at that level for several centuries.

REACTOR FACTS AND PROJECTIONS

At late count¹ 434 reactors, each with an average capacity rating of over 800 MWe were in operation in 34 countries. An additional 62 reactors (~15%) are under construction or on order. These will have a slightly larger average capacity of 850 MWe. Also, 77 reactors are no longer in service and will be decommissioned. On the average, the latter are older, smaller capacity (~330 MWe) reactors. The trend is to build larger reactors and to close down the older, smaller reactors. Almost 80% of the world's reactors now in operation are light water reactors (LWRs) and almost 75% of those are pressurized. In the U.S. 100% of the power reactors are LWRs. Thus, it appears that LWRs are an established technology in the current global nuclear electric power infrastructure.

Nevertheless, there appears to be a small but dominant public perception that nuclear power is unsafe and can lead to the use of nuclear weapons in the future. In consideration of this public perception, those who project future consumption of electricity tend to limit their projections with respect to future nuclear electric capacity and consumption.

* Lawrence Livermore National Laboratory, P.O. Box 808, Livermore, CA 94551

*presented at Global Foundation, Inc Conference
"Global Warming and Energy Policy" Ft. Lauderdale FL
Nov 26-28, 2000.*

As a result, there is considerable uncertainty on the future use of nuclear electric power in the U.S. as well as in some other countries. Sweden and Germany have decided to shut down all of their nuclear power reactors in response to political pressure from those opposed to nuclear technology.

The Energy Information Administration (EIA) projects, in its reference case, that U.S. nuclear power capacity in 2020 will be reduced to 58% of the 1997 value, although because of continuing improvements in operation, the electricity supplied will be down to only 68%. The corresponding projected reductions on a world basis are less severe, 86% and 94%. These nuclear power projections are made in the context of increased electricity consumption projections in the U.S. and the world of 33% and 76%, respectively. These data, based on EIA projections² are shown in Table 1. Thus, by the year 2020, the projections in net electricity consumption indicate an average annual increase since 1997 of 1.2% in the U.S. and 2.5% in the world.

Increased electricity use is projected throughout this century. Based on composite longer-range projections from various sources,³ conservative estimates of electricity consumption during this century are shown in Table 2. An average annual growth rate of 1.4% is projected for world electricity consumption, thus quadrupling consumption during this century. U.S. electricity consumption is projected to increase at a considerably lower rate, resulting in about 70% higher consumption by 2100.

THE NEXT STEP

With the seemingly ubiquitous and productive LWR technology in place throughout the world, one might assume that only minor advancements in reactor design could be expected. Although design changes appear to be minimal, substantial improvements in advanced LWRs result in even safer and more economical systems than the current fleet. Despite their many desirable features however, advanced LWRs do not provide a sustainable technology. Some advanced LWRs are being built in Japan and in Korea

Table 1. Current and near-term projected nuclear power capacity and consumption and total electric power consumption for the U.S. and the world.²

	1997	2020	ratio ^a
U.S. nuclear generating capacity, GW	99.0	57.0	.58
World nuclear generating capacity, GW	351.9	303.3	.86
U.S. nuclear power consumption, GW	71.8	48.7	.68
World nuclear power consumption, GW	258.9	243.8	.94
U.S. nuclear plant capacity factor, %	72.5	85.4	
World nuclear plant capacity factor, %	73.6	80.4	
U.S. net electricity consumption rate, GW	374	497	1.33
World net electricity consumption rate, GW	1400	2463	1.76
U.S. nuclear share of electric consumption, %	19.2	9.8	
World nuclear share of electric consumption, %	18.5	9.9	

^a ratio of value in 2020 to value in 1997

Table 2. Century projections³ of annual net electricity consumption rate.

	2000	2025	2050	2075	2100
U.S. net electricity consumption rate, GW	380	480	560	610	640
World net electricity consumption rate, GW	1540	2530	3570	4640	6140

where public opposition to nuclear technology has not resulted in extended, very costly, construction duration, as was the case in the U.S. with the current fleet of LWRs. Improved licensing procedures for generic advanced LWRs are now available in the U.S. These procedures are meant to eliminate licensing delays and the attendant high construction costs that have occurred previously. Unfortunately, skittish investors have not initiated plans for construction of a nuclear power plant in the U.S. for a quarter century—the new U.S. licensing procedures remain untried.

Without pursuing a program to facilitate the deployment of advanced LWRs in the U.S., the Department of Energy (DOE) has dubbed⁴ them Generation III and seemingly dismissed them as contenders in the U.S. DOE considers the advanced LWRs to be insufficiently cost-competitive in a deregulated electricity market, faced with unresolved used fuel disposition plans, and a potential means of nuclear weapon proliferation.

As a result, DOE has launched its Generation IV program,^{4,5} to consider reactor designs and fuel cycles that 1) are even more resistant to nuclear weapon proliferation than the once-through cycle used with LWRs, 2) minimize radioactive material waste and utilize publicly accepted and implemented waste solutions, 3) provide electricity competitively priced with other forms of generation with acceptable risk to capital and having short lead and construction times for new plants, 4) have low likelihood of core damage and no severe damage for plausible initiating events, and 5) meet specified safety criteria. The Generation IV program⁷ envisions research and development (R&D) on various reactor types such that a prototype plant could be operated by 2020, and a large scale deployment by 2030.

It is the thesis of this paper that the exploratory R&D on various types of new reactor concepts is unnecessary, and in fact incompatible with the large deployment schedule objective. Instead, a program to demonstrate the already highly developed modular fast reactor with fuel recycling should be vigorously pursued. Such a technology is sustainable for centuries. Moreover, it is ethically correct from the standpoint of energy resource conservation and stewardship of residue waste. It can meet all of DOE's Generation IV objectives and would allow beating DOE's target date for large-scale deployment by at least ten years. That should be "The Next Step."

Before examining the status of fast-reactor/fuel-recycling technology and means of initiating its deployment on a large scale, we address the environmental and resource considerations leading to its choice, as well as some issues that are the basis for negative public perception of nuclear power. Public perception needs to be corrected throughout the world to allow global progress on implementation of any nuclear power option.

ENVIRONMENTAL AND RESOURCE CONSIDERATIONS

Fast reactors with fuel recycling do not require uranium enrichment. Natural uranium would not need to be mined for a very long time. Instead, depleted uranium (two million tons are projected⁶ to be stockpiled at enrichment plants by 2015) would be used as makeup material for new fuel elements. The number of recycles is unlimited,

therefore discharged fuel is never in need of permanent storage. The waste product from the fuel recycling process can be designed to contain no significant amounts of actinides or long-lived fission products.

Geologic disposal would continue to be desirable for the non-recyclable waste from the fuel recycling process. However, the disposal facility requirements for this waste form would change significantly from those now being considered for used fuel from LWRs. Essentially all the long-lived fission products could be selectively removed in the recycling process (and subsequently transmuted). Waste from fuel recycling would contain no actinides, so there would not be a requirement for long-term safeguards against material diversion. Thus, the time horizon for the geologic disposal site would decrease many thousand to ~500 years. Such disposal is respectful of future generations.

Systematic retirement of LWRs as they complete their design life and their replacement with fast reactors is an appropriate evolutionary advancement in electric power generation. All of the LWR used fuel would be processed and utilized in new fast reactors. This is the technology that needs to be demonstrated as quickly as possible through construction and operation of a prototype reactor producing power to the grid.

Nuclear power reactors of any type generate electricity without the carbon dioxide emissions released to the atmosphere from fossil fuel power plants. In 1997, carbon emissions from electricity generated in the U.S. contained 532 Tg C. Had not almost 20% of the electricity been generated by nuclear plants, another 151 Tg C (~28%) would have been emitted by the additional fossil power plants that would have been required. In view of the concerns about climate change, and the possible contribution to this effect by carbon dioxide in our atmosphere, nuclear power generation has a significant positive effect on the environment.

FISSILE MATERIAL DIVERSION ISSUE

Both the nuclear weapon and nuclear power communities appear to use the single word "proliferation" or the words "nuclear proliferation" with the implicit understanding that it is in the context of nuclear *weapon* proliferation and therefore, something to be avoided. On the other hand, *proliferation* of nuclear power reactors seems to be just what is needed to solve our present and expected future electricity shortages without harming the environment. The word *proliferation* can signify a good thing! How is the general public to know what is meant if *proliferation* is used without the intended modifier? The message that the public appears to get is that proliferation of *all nuclear technologies* is a bad thing.

In any case, the public's concern should not be proliferation of nuclear weapon capability to additional countries. The public's concern should be the potential for diversion of fissile material from its intended use in a power reactor fuel cycle for making nuclear weapons or crude nuclear explosives by individuals that act with or without the approval of the material owner. Thus, it is imperative that fissile materials can nowhere be diverted overtly or clandestinely for the manufacture of nuclear explosives. This can be accomplished with intrinsic physical/chemical characteristics of the technology that is used, together with oversight by international review organizations, such as the International Atomic Energy Agency. The public must not be swayed into a paranoid position precluding peaceful uses of fissile materials and nuclear technology. Nuclear technology offers too many advantages to the health and general well being of humankind and our world environment to ignore.

Fast reactors with fuel recycling can provide electricity for centuries at a competitive cost in a manner respectful of the environment. Fuel recycling would utilize relatively inexpensive pyro-metallurgical processing and solvent electro-refining. The considerably more expensive aqueous processing previously proposed or used in the nuclear weapon and nuclear power communities was developed to produce pure plutonium. On the other hand, pyro-processing is inherently resistant to material diversion. At no time does pure, separated, plutonium exist. The presence of minor actinides in the plutonium makes it unusable directly for a nuclear explosive, as the actinides produce heat and radiation and preclude, or greatly impede, the construction of an explosive device. Some fission products remain with the plutonium, preventing hands-on theft. Process waste would not contain significant amounts of actinides and therefore, is not at all an attractive material for making nuclear weapons.

USED FUEL/WASTE ISSUE

The media and even those in the nuclear field use unclear terms relative to various aspects of nuclear technology. Use of inaccurate or ambiguous terms complicates the achievement of public acceptance of nuclear matters. For example, the term "spent nuclear fuel" uses the word *nuclear* gratuitously, unnecessarily inciting fear in the public. There is no other kind of "spent" fuel making the modifier *nuclear* necessary. Also, the terms "spent fuel" and "nuclear waste" are often incorrectly used synonymously—although the used fuel from LWRs is barely "spent" in an energy sense and should not be considered to be waste. In the past, less than one percent of the energy potential of mined uranium has been utilized in LWRs.

By whatever name we call used fuel, nuclear technology has advanced to the point that, with the appropriate reactor and fuel design, there should be no used fuel to dispose of in a geologic repository. Only a small amount of radioactive waste with insignificant amounts of actinides and a much reduced half life resulting from the advanced recycling process employed would need to be disposed of in a geologic repository.

RADIATION HEALTH EFFECTS ISSUE

A critical issue that needs to be resolved in the minds of the public concerns radiation health effects. First, a preponderance of scientific experts in the field must come to agreement. At present there is disagreement among experts regarding the effects of radiation at low levels, below ~50 mSv/y. One group believes that radiation effects are linear and that there is no threshold below which radiation is harmless. A larger group believes that there is a threshold level below which radiation is harmless, and some in this group believe that low-level radiation is in fact beneficial. Clarification of this issue is essential so that unambiguous information can be presented to the public. In view of the scientific discord, the matter has been politicized and even U.S. agencies disagree among themselves.

Resolution in favor of an acceptable threshold will have a positive effect on public attitude regarding nuclear power. Also, the acceptable radiation level that is promulgated must be based on a risk/benefit analysis in the context of other anthropogenic sources. Currently, radiation standards are established far below highly variable natural radiation levels that in the U.S. average 3 mSv/y, and without reference to higher risks from other sources that society now accepts. The unresolved controversy was recently the subject of

a review by the General Accounting Office.⁸ At present the National Academy of Sciences, through its committee known as BEIR VII (Biological Effects of Ionizing Radiation- No. 7) is reviewing the matter and plans to issue a report next year, but it is doubtful that that schedule will hold. In addition to providing the public with an accepted scientific basis for a radiation standard, considerable savings (reducing the cost of nuclear power) can be realized if the standard is not unnecessarily low.

THE FAST REACTOR SOLUTION

Fast reactors have been operated successfully at DOE installations for a number of years. Originally, it was thought that fast reactors, while also generating electric power, would be used to produce excess plutonium. The excess pure plutonium and uranium from LWR used fuel would be mixed to provide the necessary fissile content in new mixed oxide (MOX) fuel for LWRs. The nuclear power infrastructure would consist of both fast and thermal reactors and fuel recycling facilities, thus necessitating public transportation of new and used fuel. Exclusive use of fast reactors with on-site fuel recycling, that precludes production of pure plutonium now appears to be the better option.

The Advanced Liquid Metal Reactor (ALMR) program in the U.S. was in full swing and making good progress until 1994. The program goal was to develop a modular fast reactor, sodium cooled, and utilizing metallic fuel elements. The fuel would be recycled at the reactor site using improved pyro-metallurgical and electro-refining processes. Process waste would contain insignificant amounts of actinides and would not be an attractive material diversion target. This program was identified in the 1992 Energy Policy Act as dealing with a key nuclear technology that should be supported with R&D funding for a five-year period to enable future decisions regarding its course.

Unfortunately, under the negative view of the new Administration beginning in 1993, Congress did not appropriate the necessary funding to support the ALMR program after 1994 and in fact ordered the DOE to terminate the program in February 1994. On February 17, 1993, President Clinton had stated in his first speech⁹ to a joint session of Congress that: "We are eliminating programs that are no longer needed such as nuclear power research and development." The next day, at a public address⁹ in St. Louis, he expanded on his previous evening's talk: "We recommended some unwarranted subsidies be eliminated because the need for the work is much less or nonexistent anymore. For example, we recommended a big cutback in a lot of programs related to the nuclear industry and the elimination of a nuclear research program that is inconsistent with our new energy future." As a result, DOE's ALMR program was cancelled. Work at the Argonne National Laboratory (ANL) on the fuel cycle was suspended, as well as DOE-supported industrial design studies on a commercial power reactor/fuel recycling system by General Electric Co. (GE) and others, such as Burns and Roe.

Fortunately, GE continued its design studies with company funding and with support from Tokyo Electric Power Co. The current reactor design is called Super PRISM. ANL has been able to corroborate some of the fuel processing parameters that make fuel recycling viable. This information was gained as a result of performing some necessary fuel treatment resulting from the directive to shut down the experimental fast reactor in Idaho. As a result, there are sufficient data to proceed with the construction of a demonstration power reactor plant.

The Super PRISM design¹⁰⁻¹² embodies a number of features that appear to resolve many issues of concern. Particular attention has been given to reactor safety. Passive

features minimize the need for operator action and expensive backup cooling systems. Considerable savings in the cost of technology demonstration and system hardware are realized because of the modular design. A plant is composed of one to three power blocks, and each power block couples two 1000-MWth fast reactors coupled to a single-superheat turbine/generator system producing a net electrical output of 760 MWe. Thus a full size plant (six modular reactors) would produce a net output of 2280 MWe at 38% thermal efficiency. Each module has the ability to operate independently of others. Module size was selected on the basis of constraints on factory fabrication of the reactor/containment vessel.

Although as noted above the trend has been toward higher power LWRs, the modular scaling of Super PRISM is actually cost advantageous. The modular design avoids much field construction effort (reduced field time) in view of extensive factory fabrication, and allows the design to be simplified through the use of passive shutdown heat removal and passive post-accident containment cooling systems. Demonstration of the smaller, but prototypical reactor can be accomplished at reduced cost. The low cost of power also results from the higher capacity factor achieved because of modularity; generic licensing regulations; elimination of active safety systems because enhanced safety is provided by passive features; and simplicity that results in lower operation and maintenance requirements. These features all contribute to the lower cost of electricity.

Super PRISM could be operated with metal or oxide fuel and at a variety of conversion ratios. The fuel cycle using metal fuel and a low conversion ratio minimizes costs. Therefore the demonstration reactor would most likely have metal fuel and operate at a conversion ratio slightly above one (breakeven).

Specifically, it is proposed to demonstrate the operation of a Super PRISM module utilizing its considerable database. A recent economic analysis¹¹ of the Super PRISM design indicates that the cost of power, \$28/MWh for the nth of a kind plant, is easily competitive with other types of power. There doesn't appear to be a good reason to conduct exploratory R&D as proposed in DOE's Generation IV program, referred to earlier, instead of proceeding at once with demonstration of Super PRISM. Some confirmatory R&D in support of the Super PRISM design would be warranted, however.

NEAR-TERM REACTOR DEMONSTRATION

At a recent conference, Daniel Fessler,¹³ former Chairman of the California Public Utilities Commission, alluded to an imminent shortage of electric power in Brazil at the end of year 2000 as an example of the worldwide need for clean responsible sources of electricity. He challenged the conference participants to move nuclear power construction out of its apparent hiatus and thus rise to the challenge of the projected worldwide electricity needs. He emphasized the urgency for the nuclear community to proceed on these matters with the comment that "...one shouldn't wait ten weeks to begin a task that must be completed within ten years."

Mr. Fessler's remarks give rise to serious thought and a resulting multifaceted solution to advance the acceptability of nuclear power technology throughout the world. Demonstration of Super PRISM in any country, under international auspices, would be of benefit to all countries. Such a project could be accomplished in Brazil, or in another suitable country, within a ten- to fifteen-year time frame.

THE BRAZIL DEMONSTRATION VENUE

Although the fast reactor/fuel recycling demonstration project could technically be conducted anywhere in the world, it would be desirable to perform the demonstration in a developing country, preferably, from a neighborly viewpoint, in the Western Hemisphere. Countries, such as the U.S., France, and Japan, where nuclear power is in relatively wide use, have run into public perception problems regarding new nuclear projects. Although perceptions are changing, the public in these countries does not currently appreciate the need to develop advanced nuclear power plants.

By various measures Brazil is a key world country. It ranks fifth in land area and in population among the world's ~220 countries. Brazil is a significant generator and consumer of electricity. In 1998, Brazil generated 36.2 GWy of electricity, ranking tenth in electricity generation among world countries. The top ten countries together generated over two-thirds of the world electricity. Over 90% of Brazil's electricity is hydroelectric. Brazil's per-capita usage will more than double by 2020 according to U.S. projections.² Brazil's population is projected to increase less than 25% by 2020. In the same projections, however, electricity consumption is predicted to increase by a factor of 2.8, carbon emissions by 2.6, gross domestic product by 2.4, and total primary energy use by 2.1.

Until recently, Brazil had only one operating reactor, Angra 1, a 657-MW Westinghouse PWR. Lifetime performance of Angra 1 since its startup in 1982 has suffered. However, its lifetime load factor of only 28.1% improved to 60.9% for the year ending June 1999. A second reactor, Angra 2, a 1300-MW Siemens-KWU PWR, was recently completed. It achieved first criticality on July 14, 2000 and 100% power soon after. Work had been suspended on a third reactor, Angra 3, similar to Angra 2 at the same site. A financial strategy is being developed for continuation of the Angra 3 project that would commence operation in 2006. These two larger units would add ~6% to the 36.2 GW of electricity generated in Brazil in 1998. Longer-term plans through 2015 include a possible Angra 4 reactor (similar to Angra 2 and 3) and a fifth reactor of an unspecified type. A Super PRISM demonstration project in Brazil is not inconsistent with continuation of those plans, as used fuel from the LWRs could be applied to startup inventories of fast reactors that would most likely be adopted in the future.

Because currently Brazil's electricity is mostly hydroelectric, carbon emissions from electricity generation are practically negligible. In 1990, carbon emissions from electricity generation in Brazil were 0.09 kgC/Wy compared with 1.54 kgC/Wy in the U.S. Clearly, Brazil's electricity has not contributed to climate change. But dams are no longer popular in Brazil. Agricultural interests are said to be harmed by further dam construction; rainforests would be flooded thus impacting the world environment; and long distance electricity transmission would be required because of the remote location of the new dams that would be constructed.

Brazil has limited fossil fuel resources. Oil provides primary energy at the rate of 85 GW, with almost 40% of that imported. Indigenous coal and gas contribute only ~20% as much primary energy, and ethanol, made from sugar cane, contributes another ~20%. Recently a 3000-km natural gas pipeline, costing \$2B, was built from Bolivia to Brazil. Its current capacity is about 11 billion m³/y or about 13 GW of primary energy. If used exclusively for electricity generation in highly efficient combined-cycle gas plants, 7 GW of electricity could be generated, or less than 20% of the 1998 generation. It should not be assumed, however, that the cost of electricity from such gas plants would be lower than from a Super PRISM plant.

If the admirable carbon emission performance of Brazil is to continue, new electricity capacity from nuclear and renewable power resources will need to be brought on line to meet the ever-increasing requirement for electric power. A clear solution to Brazil's electricity needs appears to be expanded use of nuclear power. Nuclear power is the leading contender as a future substitute for hydroelectric power, if carbon emissions are to remain low. In view of Brazil's enviable record on carbon emissions from electricity generation, and the projected competitive cost of power through the use of Super PRISM technology there does not appear to be a better solution.

Although Brazil's experience with nuclear technology is limited, they are a signatory of the Nuclear Weapon Non-Proliferation Treaty, have considered development of nuclear powered submarines, have developed isotope enrichment technology, and accept international regulations for safeguards of nuclear material. The initial inventory of fuel for the Super PRISM demonstration reactor could be provided from the used fuel projected to be discharged from Brazil's LWRs by 2010.

Because of Brazil's historically limited nuclear power exposure, demonstration of a fast reactor/ fuel recycle system in Brazil should meet with less public opinion resistance than in countries with a more entrenched anti-nuclear technology sector. Brazil's electricity needs would be met, and also the world public would benefit from the Super PRISM demonstration and its subsequent deployment throughout the world.

PROJECT INITIATION AND MANAGEMENT

In order to initiate the demonstration, some funding is required to conduct preliminary studies of specific issues, establish the participants, develop a project plan, and secure approvals and funding. A key goal of this initial effort would be to win the genuine interest of the host government (for example, Brazil) in the demonstration project and obtain its permission and facilitating support for conducting the project. The resulting project plan would form the basis for a "full-ahead" direction to proceed. Success of the Super PRISM demonstration is highly dependent on the quality of its leadership. The participants would clearly include a number of industrial and government organizations from throughout the world. Active participation by university personnel and of nuclear technology associations would be encouraged.

The project should be conducted as much as possible on a private business basis in order to avoid government entanglements. Experience gained from this project would benefit various world governments, businesses, and organizations. Because of first-of-a-kind risks and its global importance, their subsidies should be solicited to defray part of the cost of the Super PRISM demonstration.

IN CONCLUSION

Although the suggested demonstration project of Super PRISM cannot fill short-term needs for electricity, an immediate start appears essential. This urgency is dictated by the continuously increasing use of electricity, throughout the world and the global need to maintain low carbon emissions. Every effort should be made to complete the remaining development of the Super PRISM reactor and complete construction of the demonstration reactor by 2015 at the latest to allow wide-scale deployment to be in place by 2030, consistent with DOE's Generation IV objectives. With an early project start, a qualified management, and dedicated world project team players, such a schedule, needed

to satisfy future world electricity demands could be met. In fact, it appears that Super PRISM is the only viable technology that can meet the requirements recently set forth by the nine-nation group that includes U.S., Brazil, and Argentina for Generation IV reactors.

The ultimate desired outcome of the Super PRISM demonstration project is adequate, affordable amounts of safe, clean, sustainable electric power throughout this century and beyond for all the world. No more carbon in the atmosphere caused by electricity generation! No more used fuel disposal issues! No more concern about million-year integrity at geologic repositories. No more concern about dwindling energy resources for electricity generation! Multiple replicas of the demonstration reactor and phase-out of fossil-fueled electricity generators would accomplish this purpose.

ACKNOWLEDGEMENTS

Data on Brazil electricity generation were obtained from various Energy Information Administration sources. Extremely helpful discussions were held with Jose Mauro Esteves dos Santos, Antonio Carlos de O. Barroso, Jorge Spitalnik, and Everton Carvalho, key individuals in Brazil's nuclear energy organizations. However, conclusions about the potential of Brazil as a venue for demonstration of Super PRISM technology are the author's alone.

This work was performed under the auspices of the U.S. Department of Energy by Lawrence Livermore National Laboratory under contract No. W-7405-Eng-48.

REFERENCES

1. World List of Nuclear Power Plants, *Nuclear News*, p 35-58, March 2000.
2. International Energy Outlook 2000- With Projections to 2020, Energy Information Administration Report, DOER/EIA-0484(2000), March 2000.
3. Walter, Carl E., Directions for Advanced Use of Nuclear Power in Century XXI, Proceedings of American Nuclear Society Global '99 International Conference on Future Nuclear Systems, Jackson Hole, WY, August 30-September 2, 1999.
4. Generation IV: Looking to the Future of Nuclear Power, U.S. Department of Energy, Office of Nuclear Energy, Science, and Technology, January 2000.
5. Discussion on Goals for Generation IV Nuclear Power Systems, from a Workshop held May 1-3, 2000, July 31, 2000.
6. Lindholm, Ingemar, Depleted Uranium: Valuable Energy Resource or Waste for Disposal?, Uranium Institute 21st Annual Symposium (1996).
7. Annual Energy Outlook 2000- With Projections to 2020, Energy Information Administration Report, DOER/EIA-0383(2000), December 1999.
8. Radiation Standards- Scientific Basis Inconclusive, and EPA and NRC Disagreement Continues, Report to the Honorable Pete Domenici, U.S. Senate, U.S. General Accounting Office, GAO/RCED-00-152, June 2000.
9. Feb 17, 18 1993 speeches: <http://www.whitehouse.gov/library/index.html>.
10. Boardman, Charles E., et al, A Description of the S-PRISM Plant, Paper 8168, Proceedings of ICONE 8, 8th International Conference on Nuclear Engineering, Baltimore, MD, April 2-6, 2000.
11. Boardman, Charles E., Allen E. Dubberley, and Marvin Hui, Optimizing the Size of the Super PRISM Reactor, Paper 8003, Proceedings of ICONE 8, 8th International Conference on Nuclear Engineering, Baltimore, MD, April 2-6, 2000.
12. Dubberley, A. E., C. E. Boardman, K. Yoshida, T. Wu, Super PRISM Oxide and Metal Fuel Designs, Paper 8002, Proceedings of ICONE 8, 8th International Conference on Nuclear Engineering, Baltimore, MD, April 2-6, 2000.
13. Fessler, Daniel, Concluding plenary talk at the American Nuclear Society's Global '99 Conference on Nuclear Technology- Bridging the Millennia, Jackson Hole, WY, September 2, 1999.

2001-001765 1/24 1:06

12 January 2001

Senator and Secretary of Energy
Designee Spencer Abraham
1800 G Street NW
Washington D.C. 20006

Re: National Energy Policy

Dear Sen. Abraham:

I have written five opinion/editorials on our energy problems, which I enclose, plus an editorial by Mary L. Walker and a letter to President-elect Bush.

My main concern is that our national energy policy should give a prominent role to nuclear energy, since it is the only affordable source that is clean, green, and non-polluting. These outlandish sounding claims are explained in my editorials, which I have been sending to dozens of major newspapers in the West and across the country.

The most immediate ways to deal with the energy crisis are calls for energy conservation (including restoring tax credits for such) and gas powered peaking plants. Next would be encouraging new baseline plants, but of what type?

Smoke from U.S. coal plants kill an estimated 30,000 per year and are a major factor in global warming. Oil may be slightly better. Nuclear plants can now be built in 4.5 years, using pre-approved plans, as was done for Tokyo Electric Power Co. (see pages 76-77 of *Nuclear Power: Villain or Victim?* by Emeritus Professor Max W. Carbon, who may be contacted for a copy at 608-831-3914 or by e-mail at pbp@midplains.net).

I don't know if Congress has streamlined the application process yet, as mentioned in the same pages of Carbon's book (Clinton would probably have vetoed it), but it would allow us to match the 4.5 year construction time. Congress should also reimburse the power industry for lost investments in reprocessing under Pres. Carter, and restore funding to the IFR program. These steps would give a needed green light to the nuclear power industry, but also include elements to please some environmentalists (energy conservation and progress on global warming or the Kyoto protocols).

Congratulations on your designation as Secretary of Energy.

Sincerely,



Steven C. Barrowes, Ph.D.

Member, Scientists for Secure Waste Storage

Attachments

29471

HOLD ONTO THE FLASHLIGHTS

by Steven C. Barrowes, Ph.D.

(1/12/01
Draft)

A group of us young men seeking adventure took flashlights and set out to explore an old mine near the Holladay Gun Club in the foothills overlooking Salt Lake City. The old mine was a tangle of interconnected tunnels and chambers, which seemed to go on and on. We would never have gone in more than a few feet without flashlights, not knowing where we could step safely.

One of our more sensible members started to worry about how long we had been in and whether we knew the way out. By the time we finally found our way out an hour or two later, the faint blue of the deepening night sky was most beautiful.

Flashlights got us in and, in spite of one or two going dim or out, flashlights got us out again. While we were trying to remember the way out, it would have been the sheerest folly to blame the tools that got us in there and try to find our way out without flashlights.

In a similar way chemistry has been a tool with many benefits, but it has also left us with chemical pollution byproducts in many places and many forms. Chemistry got us into this predicament but is also the tool that can get us out, if we restrict future pollution and spend the effort necessary to clean up the old messes.

Radioactive pollution came mostly as a byproduct of the cold war nuclear arms race and the peaceful production of electric power. The arms race was seen as a matter of national survival, which allowed little attention to questions of pollution. The nuclear power industry had confidence that safe methods of dealing with the spent nuclear fuel (SNF) would eventually be found.

With the cold war ended and an accumulation of SNF to add to the weapons byproduct waste, it is time to deal scientifically with the waste problems. Research must be encouraged to find newer, cleaner solutions, unless these have already been found. If they have been found, they must be put to good use and further refined. Now is not the time to drop the flashlights and panic.

In fact science has found a way to greatly simplify nuclear waste problems. The key is to reprocess the SNF or high level waste, completely separating the fission products (true waste) from the actinides (uranium, plutonium and heavier nuclei). The fission products can be melted into glass (vitrified) where they become harmless after storage for only 300 years, not 10,000. The long-lived actinide isotopes can be put into new fuel rods where they can be completely burned in an Integral Fast Reactor (IFR) for clean energy.

Unfortunately the IFR program has been destroyed, but it could be completely rebuilt because scientific articles about it still exist. Reprocessing of

(over)

spent fuel was banned without financial compensation under the Carter administration, yet authorized again under President Reagan. But because the huge losses under Carter were never compensated for, the nuclear utilities have never again invested hundreds of millions of dollars to start SNF reprocessing.

A number of our allies are reprocessing to recover the 95 percent of unused fuel in SNF and/or to have a way to safely and completely use up old weapons plutonium. Russia and Japan have even made a business of it, accepting old SNF from other countries and netting their future energy supply in the process. Meanwhile we are still bent on burying our future energy permanently in Yucca Mountain, when it would be far wiser to store it above ground in Utah's western deserts, at either the Private Fuel Storage site on the Goshute Indian Reservation or at the Pigeon Spur site, farther from civilization. This would make the SNF more accessible to us when reprocessing begins.

With the California electric power crisis affecting a dozen western states and threatening to spread even further, it is time for the new Congress and the new Bush administration to think about solving this crisis by encouraging new nuclear power plants. No other affordable power would be as clean or avoid adding to global warming. If instead we meet the need by doubling the number of U.S. coal-fired power plants, the smoke may kill another 30,000 people yearly. Radiation from American style nuclear plants has killed no one yet, and these plants have a most enviable safety record.

The IFR program was dismantled by the Clinton/Gore administration, apparently to please environmentalists who oppose all things nuclear and have little foresight or concern for our future energy needs. Every form of affordable electricity is opposed by one environmental group or another, leaving us facing a power crisis with no new baseline power plants planned or under construction, while we expect an increase of 60 percent in demand for electricity over the next 20 years. The IFR reactor itself was completely dismantled several years ago and parts sent to several destinations to be destroyed. Our leaders' apparent plan was to calmly dismantle the flashlights, scatter the parts, and then be surprised if, by chance, panic ensued.

Dr. Steven C. Barrowes has taught physics at several universities and is a member of Scientists for Secure Waste Storage

of Utah, LSU in Louisiana, MSU in Mississippi, and ISU in Illinois. You may contact Richard Wilson, Mallinckrodt Prof. of Physics at Harvard, on SSWS, at 617-495-3387.)

text 841

B6

2 January 2001

Re: Chernobyl: Nuclear Titanic

Dear Editor:

The parallels are strong. Both were engineered with too much confidence that no disaster could happen to them, and thus with too little effort to build in safety features. Both were also operated recklessly.

The Titanic was built with too few lifeboats, the steel in the hull was too brittle, and the captain continued at full speed even when warned of icebergs in the north atlantic shipping lanes. The resulting disaster claimed 1,500 lives.

Russians have been known to ignore safety rules in their science and technology, which one might expect from a totalitarian society where citizens could not sue for damages and where the government could hide bad news.

Chernobyl type reactors are unstable at low power levels, where the plant manager was running the plant at the time of the accident. In addition, against the advice of the reactor staff, while he himself had no nuclear training, he was conducting an experiment on the turbine and generator. To do his experiment he shut off several control devices which would have automatically turned off the reactor. What was he thinking?

After Titanic, U.S. and English maritime laws were tightened to insure safer equipment and practices. There was no cry for shutting down all passenger ships or claims that ships could never be run safely. Likewise, after a reckless-driver accident there is no cry to ban all cars. Such illogic is only heard from activists against nuclear power.

Nuclear power plants, wherever U.S. style plants are used, have an enviable safety record. They also save tens of thousands of U.S. lives yearly because they emit no smoke, and they are the only affordable source of more electricity that doesn't increase global warming. Are they not the gateway to a healthier environment?

Sincerely,



Steven C. Barrowes, Ph.D.
Member, Scientists for Secure Waste Storage

text 295

29474

Scientists Already Have a Complete Solution for Spent Nuclear Fuel

12/17/2000
Salt Lake Tribune

BY STEVEN C. BARROWES

Anti-nuke activists ask for a complete solution to the nuclear waste problem before allowing interim storage of spent nuclear fuel (SNF) on the Goshute reservation or on Utah's other site at Pigeon Spur. Their request makes very good sense, as does looking before we leap or getting a plan before committing ourselves to action.

What they don't realize is that science already has a good plan, a complete plan. All that is lacking is getting the political components lined up — getting the voters and politicians to listen and understand how well the plan would work.

Critics of the idea of storing SNF at the Goshute reservation or at Pigeon Spur, the two U.S. sites which have applied for a license, very correctly complain about a plan to store material they have been told will remain lethally radioactive for 10,000 years.

The little-known good news is that science can reprocess SNF in such a way that the true waste or fission products are

melted into glass (vitrified) and become harmless in less than 300 years, while the remainder is put into new fuel rods to be completely burned for clean energy.

The key to this great increase in safety is to transfer all the actinides (uranium, plutonium, and heavier elements) into new fuel rods, to be used for energy. Without any actinides in the waste, no significant waste isotope has a long half-life.

A new type of reactor called an Integral Fast Reactor (IFR) uses these fuel rods in a way that eventually burns up all the actinides for energy. The scientific problem is thus solved by separating all usable fuel from the true waste. In spite of this, the Clinton administration has stopped the funding for continued research with the IFR.

Apparently, President Clinton followed the lead of environmentalists who for decades have fought against nuclear electric power with no regard for causing such environmental disasters as global warming and the killing of tens of thousands of U.S. citizens yearly by smoke particulates from coal- and oil-fired power plants.

This decision against continuing the IFR research program was damaging, but not as damaging as the decision under President Carter to ban U.S. reprocessing of SNF. At that time the electric utilities had one working reprocessing plant and two others under construction, at a cost of several hundred million dollars. These were made useless by the ban.

Although President Reagan removed the ban, the utilities were never compensated for their losses. Thus they still have not restarted reprocessing for fear of more such treatment from the government. A bill in Congress to compensate those losses and restore funding for the IFR program would set this country on the path to a complete and very positive solution to its nuclear waste challenges.

Solving our nuclear waste problem in this manner has several big advantages: (1) It recovers the 95 percent unused uranium in SNF to provide future energy; (2) It greatly simplifies the waste problem, as mentioned; (3) it provides a method for using bomb-grade plutonium and U235 uranium for clean energy, thus eliminating

old weapons stockpiles; (4) it provides a way to use up stockpiles of U235-depleted uranium (mostly U238) left over from weapons production; (5) it allows for eventual discontinuance of coal- and oil-fired power plants so the U.S. can meet the greenhouse gas emission limits set in the Kyoto conference, and (6) it extends our U.S. nuclear energy supply to last thousands of years.

What is the price we must pay for all these advantages? Very little.

In previous editorials, I have pointed out the safety of shipping and storing SNF. Not one person living along the busiest railroad line could get the equivalent of a fourth of one chest x-ray by leaning against the fence while all 4,000 SNF casks went by.

Using 30 mph dedicated trains, no credible accident would require an expensive cleanup or release radioactive material into the air, land or water. The nearest residents to the Goshute project, 4 1/4 miles away, would take at least 20 years to get the equivalent of one chest x-ray.

I calculated the expected deaths along

the transportation route: The result was less than one death, or closer to a zero chance of one death.

The main price for these many benefits is that we overcome our unfounded fears and consider the realistic risks vs. benefits. The U.S. safety record for over 3,000 SNF shipments and for running 103 nuclear electric plants is not one person killed by radiation, yet, while after great safety improvements for coal miners, three dozen still are killed per year.

Risks must be analyzed and evaluated to make rational safety decisions, and our political leaders should listen carefully to scientific experts on questions of science. Will capable political leaders be driven by irrational, non-mathematical, unscientific opinions or seek diligently to reach a wise decision in accord with the best information available?

Steven C. Barrowes has taught physics at several universities, including U. of U., LSU in Louisiana, MSU in Mississippi, and ISU in Illinois, and is a member of Scientists for Secure Waste Storage.

I. Arthur Hoekstra, PE

1/14/2001

To energy designers:

Following is a recent article from the Buffalo News describing plans to heat downtown and a copy of my letter to Marc A. Coppola. Also enclosed is a copy of the title page of my patent, which is ideally suited to installations like this.

As I explained to Mr. Coppola, my letterhead shows ~~PE~~, which shows that I no longer practice engineering. I am 80 years old and I let my license expire. I had my vision years ago but I was never successful in marketing the idea because energy was so cheap that there was no interest. Today however energy costs are high as Mr. Pitts in the article says, "particular interest is in central urban areas where energy costs are skyrocketing.

The city of Buffalo would need engineering help and finances to help them follow my ideas but the concept will also be ideal for many communities across the country and across the world. I hope that someone will take advantage of my design.

Sincerely,

I. Arthur Hoekstra

Panel to study ways to heat downtown

By THOMAS J. DOLAN
News Staff Reporter

It may be one of the coldest winters on record, but one city lawmaker is dreaming of warming up downtown Buffalo with new energy.

Delaware Council Member Marc A. Coppola and three fellow lawmakers were named Wednesday to a special committee on energy.

Coppola says the panel will immediately begin exploring new proposals for generating heat and power in the downtown area, including district heating and co-generation.

"We cannot sit here and wait. There is money available at (the federal Department of Housing and Urban Development). We can't . . . let it go," he said.

Others named to the committee by Common Council President James W. Pitts are Lovjoy Council Member Richard Fontana, Ellicott Council Member Barbara Miller-Williams and South Council Member Mary M. Marino.

According to Pitts, the new committee will be responsible for finding ways "to conserve and explore alternatives for greater energy cost efficiencies for the city."

Coppola said federal housing officials appear to be prodding the city to expand its energy conservation efforts, which now involve a district heating system at Fire Department Headquarters.

A boiler located there supplies heat to City Hall, City Court, the Buffalo Athletic Club, Rush County Office Building and the former City Court building at Delaware Avenue and Eagle Street.

But according to Coppola, there are possibilities for expanding the system to heat more downtown buildings. And it might also be possible for the city to produce electricity, heat and hot water using the same power plant, a process known as "co-generation."

"Those are some of the first things we're going to be looking at," he said.

Coppola, who was trained as a stationary engineer, said new, highly efficient co-generators can fit in a space the size of a trailer.

Pitts noted in his announcement that federal housing officials are interested in developing a national model for how cities could devise new energy-saving projects.

" . . . particular interest is in central urban areas where energy costs are skyrocketing," he said. W

De
Anne and Hugh Simmons

002475

January 14, 2001

2001 002475 1/30 A 11:35

Hon: Spencer Abraham, Secretary
U.S. Department o. *Energy*

Dear Mr. Secretary:

The new administration is to be commended for suggesting the need for a national energy policy. I believe that one that is concerned with our grandchildren's future will be the one that will make the most economic and political sense. I hope it will include the following elements.

1. Use our national lands and preserves in an environmentally sensitive way to increase domestic production. Provide incentives so that "stripper" wells can continue to produce. Its infrastructure is already in place; why waste it?
2. Continue and expand the subsidies to encourage the use of ethanol. It is a win-win situation for the environment, our agriculture industry and our trade balance.
3. For the long haul, develop by every means possible (research, subsidies and tax policy) the great potential of solar energy. First don't be deterred by the earlier failures in this. Those of us in the American Plains know that there are enough sunny days and prevailing winds to provide the whole country with all the electrical energy we will ever need. We just need to be willing to make the research and infrastructure investment to get it. It is important for another reason. Japan already has a leg up on us in photovoltaic energy for the world market. Get your staff to find out what Sanyo and Kyocera are doing. There is going to be a huge world market for such devices and we could be the leaders in it.

If you have read this far, I want to thank you for listening. Best wishes for a very successful congressional session.

Hugh
Hugh Simmons

P.S. Congratulations on your appointment. We need people who can help guide the new president to the center of American thought with policies that will have broad appeal. We don't need to go through another "barely made it" election.

29477

2001-002736 2/1 A 11:55

002136

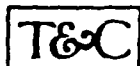

Town & Country  Center

81557 DR. CARREON BLVD. SUITE A3
INDIO, CALIFORNIA 92201
(760) 347-4664

January 23, 2001

Secretary Spencer Abraham
Department of Energy
1000 Independence SW
Washington DC 20585

Re: ENERGY POLICY

Dear Secretary Abraham:

Congratulations of your appointment as Secretary of Energy. And particularly pleased to see a Michigan man honored.

On a recent cruise I met a retired Texas geophysicist* who had worked on oil projects in countries all over the world. He understands the practical facts about the oil business, worldwide capacities and the "Archilles Heel", namely refinery capacity.

My thought is that he would be a good person to talk to while you are working on an Energy Policy for the United States. As an old trial lawyer and Judge, I know the importance of learning the practical facts before making a determination.

Good luck in your new position.

Very truly yours,

Richard M. Marsh

RMM/lis

* CLYDE W. KERNS []

66

29478

25-E
DOK

Lighty

1-26-01

2004206

George W. Bush
President of the United States
The White House
1600 Pennsylvania Avenue
Washington D.C.
20500

From: This service can be requested for Recipient's records.
Date: 29 JAN 2001 FedEx Tracking Number: 824982388015

Sender's Name: CHARLES L CAMPBELL Phone: _____

Company: _____

DB

Subject: US Energy Crisis & Related Problems

Address: _____

Dear President Bush:

City: _____ State: _____ ZIP: _____

I would like to congratulate you on your inauguration and wish you well in your next 8 years in office. I appreciate the concise legislative program you have laid out; however, there is an immediate domestic problem, which was not included and will grow to crisis proportions if not handled immediately from your office.

I was the senior supply officer of Gulf Oil Corporation during the 1974 and 1980 energy crises. The current power situation in California added to the pricing problems for heating oil and natural gas in the North features the same public hysteria and political accusations of those earlier periods. In all supply crises the political solutions are generally wrong. Former Israeli Foreign Minister Abba Eban once said: "History teaches us that men and nations behave wisely once they have exhausted all other alternatives." The US did not behave wisely in 1974 or 1980 and your administration has the opportunity to correct the irrational actions in those earlier periods that are adversely affecting our nation today and are exacerbating the current situation.

The gold rush of technology stocks ended with the government's assault on Microsoft. The judge's decision on the suit triggered the NASDAQ meltdown and a trickle down effect that reaches a very wide group of citizens. dot.com company employees now have worthless stock options and are scrambling to meet the monthly payments on their new Mercedes and mansions. Day traders used their life savings to cover margin calls. The savings rate for the US has been negative for the last year.

Holiday retail sales were at the lowest level in 10 years. Inventories of all manner of industrial and consumer goods are rising. A large number of companies are reporting lower profits. All US automobile companies are seeing significantly lower sales; Chrysler will probably disappear as a viable entity. The major US steel companies are in serious trouble. Declining automobile sales will also affect other major industries - steel, aluminum, rubber, chemicals, glass, etc. - in a repeat of the 1980 energy crisis.

While the end of the information technology bubble has little to do with the beginning of the current energy crisis the results feed on the energy related issues. The confluence of long ignored energy problems; OPEC's new resolve on pricing and the crash of the dot.com society have set up the potential for "The Perfect Recession". Any tax relief proposed by your administration will be small compared to the monthly increases in energy costs now being experienced nationwide. The cost of natural gas to the California power companies is immediately translated to gas, heating oil and diesel fuel across the country.

Starting in the 1980s a variety of counter productive forces were introduced to our society which ultimately has lead us to the path of becoming a third world nation in terms of quality of life and civil frustration. All of our current problems have been self induced. As Pogo once said " We have met the enemy and he is us."

Specifically:

- 1) The two major power suppliers on the west coast Southern California Edison and Pacific Gas and Electric are nearing bankruptcy. A similar situation surfaced earlier in the Midwest and was ignored. California's power problems will spread to other states if action is not immediate. These problems effect the entire population and are a major driving force in reduced economic activity by companies and individuals.

A recent Wall Street Journal article on California states: "Rolling blackouts shut down businesses, dimmed households and threatened California's citrus crop. People were trapped in elevators and traffic was snarled. Supermarkets were crowded with customers buying flashlights and firewood. California Steel Industries Inc. shut down its steel rolling lines." Other reports have small businesses closed and/or on the verge of bankruptcy.

No new power plants have been built in California in the last 10 years as a result of the chaos of deregulation and the onerous environmental regulations. These points can be argued endlessly but the fact remains that electric power usage continues to grow at an aggressive rate and peak shaving equipment has become base load equipment with rolling blackouts and massive price increases during the peak periods.

- 2) Excessive gasoline, natural gas and heating oil prices have also impacted US economic development over the same time period. Nation wide heating oil, diesel fuel and natural gas prices are in fact directly related to the California electric power prices. But petroleum products prices would have risen irrespective of the electric power crisis. No new refineries have been built in the US since 1975 and during the 1980s refining capacity in the US was reduced from 18.5 to 15.5 million barrels per day as refiners decided to shut down facilities rather than install government mandated equipment which added no value to the finished products.

As a separate issue petroleum products have greatly reduced fungibility. This means that products may no longer be easily transferred from one region of the country to another to balance supply shortages because of regional EPA and CARB regulations which give rise to a geographical patchwork of incompatible quality specifications. As with electric power, petroleum product demand will continue to grow with no matching construction of new refining capacity.

Finally, imported oil has risen from 37% of US demand in 1980 to 52% in 2000 and will grow to 63% by 2020 if the current attitude toward energy continues. This is a drastic drain on our economy via our balance of payments.

A parallel problem relates to national security. The current Saudi government is run by the direct lineage of King Ibn Saud; they are now all over 70. The policies of both Iran and Iraq are always to create mischief for Saudi Arabia with the intention to bringing down the current government. Additionally, problems with the religious fundamentalists Wahhabis within Saudi Arabia have not changed in the last 25 years. The only US government officials who totally understood the Muslim nations were Kermil Roosevelt and Jim Akns and Mr. Akns left Saudi Arabia in the mid-1970s.

The hand over of the government to the next generation of Saudis will probably occur on your watch with the potential for a high degree of instability. If Saudi Arabia fails so do Qatar, Kuwait and the Emirates. This will leave the US (and the rest of the world) extremely vulnerable to an insecure crude supply. Think about the Iranian revolution and the start of the Iranian-Iraqi war in 1980; this period should be considered relatively minor compared to the fall of Saudi Arabia to a Saddam Hussein or his Saudi equivalent.

- 3) Transportation congestion has reached a critical mass and is leading to air/road rage as well as a very inefficient business environment. In addition to the frustration of long traffic delays, commuting by automobile compared to rail transportation is extremely inefficient on an energy use basis. During the last 12 months there were significant gains on San Francisco's rail system in direct response to high gasoline prices.

Jet fuel consumption is impacted directly by a transportation system that uses fuel sitting on the ground, circling in holding patterns and diverting passengers to the wrong locations. Hydrocarbons used as jet fuel compete directly with demand for home heating oil, diesel fuels and power plant fuel. A quarter of all flights, affecting 119 million travelers, were delayed, canceled or diverted in 1999. Customer complaints were up 16% over the prior year. As the air travel infrastructure approaches 100% of operating capacity any minor problems quickly expand exponentially to the entire US transportation grid. As with power and refined product demand, individual and business travel continues to expand with a transportation system which has been inadequate for the last 10 years.

Most of the technology to solve these problems has been available for years and has been implemented in other countries. The bureaucratic impediments to the solution are home grown and must be dealt with politically.

In any problem solving activity - whether the problem is economic, political or technical - there are several degrees of freedom. Once you have set limits on certain degrees of freedom the outcome becomes a known solution. The following are limits to the degrees of freedom which need to be included in any US energy policy.

- A) Limit US reliance on foreign sourced hydrocarbons
- B) Limit environmental pollutants
- C) Limit US balance of payments
- D) Limit global warming

All of these limits can be reached with a rational energy policy and at the same time expand economic growth. However, no matter how many rocket scientists are locked in a room to solve the US energy and economic problems the answer will always come out the same. In terms of a rational energy policy technical solutions will take 5 to 10 years but political action required to implement these technical solutions is required immediately. There are some short term solutions which violate the above limits in order to protect the economy and national security but the ultimate solution must result in a reduction in the use of hydrocarbons and a reduction in foreign energy imports as well as a reduction in governmental impediments to the solution.

Exhibit 1 provides the basis for a rational energy policy. I have enclosed a document which gives the logic for each of the 10 points as well as a paper I presented 20 years ago to a wide variety of government bodies, public forums and university groups. Sadly the US situation is worse today than it was in 1980. I have also enclosed a paper by Texaco prepared in 1980 that also has been ignored. The results are now in; we were right.

I am not looking for a federal job. However, I have had considerable first hand experience with consuming and producing countries' oil ministers, US government agencies and consumer groups during periods of instability. I lived through governmental blunders in similar crisis periods. If any of this experience is useful I would be please to discuss what works and doesn't work with your staff and the Energy Department.

Sincerely yours

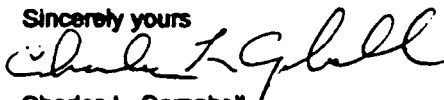

Charles L. Campbell

23 January 2001

A REALISTIC NATIONAL ENERGY POLICY

Short Term Solutions

- 1) Return electric power to a regulated format of 1990 with modifications for co-generation and power supplied by small businesses and individuals to preferentially enter the grid. The country had a low cost and extremely reliable power system until deregulation was instituted.
- 2) Return to US gasoline, heating oil and diesel fuel specifications of 1990 to provide fungible products.

Long Term Solutions

- 3) Reduce governmental restraints that impede the immediate installation of coal fired power generating facilities by individual local companies as well as new nuclear plants and refining capacity.
- 4) Set up a national company to build nuclear power plants with a common plant design and plants operated by graduate electrical engineers.
- 5) Install high speed electric train service in high population density areas of the US using a common technology.
- 6) Set up a national research program to reduce the cost of photovoltaic cells.
- 7) Set up a government purchasing program for fleets of electric cars to be used by government employees.
- 8) Through taxation of petroleum products and/or taxation of new vehicle purchases allow markets to penalize low mile/gallon vehicles and reward high mile/gallon vehicle purchases.
- 9) Set up a national company to construct and operate coal liquefaction and gasification plants on the US Gulf Coast using western coal reserves transported by pipeline slurry and imports.
- 10) Open governmental lands to oil/gas exploration.

A REALISTIC ENERGY POLICY

A REALISTIC ENERGY POLICY

Degrees of Freedom

The following are limits to degrees of freedom which are required in any US energy policy:

- A) Limit US reliance on foreign sourced hydrocarbons
- B) Limit environmental pollutants
- C) Limit US balance of payments
- D) Limit global warming

Short Term Solution

- 1) Return electric power to a regulated format of 1990 with modifications for co-generation and power supplied by small businesses and individuals to preferentially enter the grid.

Electric power is unlike any other commodity. There is no technical capability to store power. There is no technology available to import power except from contiguous nations

There are two peak periods during each day – morning and evening. There are also seasonal peaks. Storage capacity for these peak periods can only be met by a large excess of generating equipment which is idle a very high percentage of the time and transmission grids which are normally under utilized.

Prior to deregulation all power generating companies were local monopolies with a pricing structure related to capital costs which provided guaranteed rates and allowed the companies to have idle standby equipment to cover the peak needs of their customers. Service was extremely reliable and the costs very low.

New power plants are not being constructed to provide excess capacity. Environmental regulations restricting the construction of new plants were becoming more severe about the same time as deregulation was being proposed. However, the primary reason that companies are not building new capacity is that rates are no longer guaranteed and no one is going to construct plants that sit idle most of the time.

The Midwest gave a forewarning of the effect of the "free market" in the summer of 1998 when Federal Energy Sales, a new small energy market company, defaulted on power contracts and threw chaos into an already stressed power generation/distribution situation. The result was extremely high spot power prices and rolling blackouts for the entire area.

No one seems to understand that the underlying problem is related to an assessment of degrees of freedom. If you give companies a monopoly position and a guaranteed rate of return on their assets in exchange for guaranteed supply they will comply. If you give them the freedom to act as entrepreneurs with no guarantee of returns they will provide only those assets that will generate profits. With no guaranteed profit on facilities which sit idle most of the time waiting for a short term peak in power no one will build the peak shaving equipment.

The 1998 mid-west crisis was a warm up for California. No new facilities have been built in the last 10 years, the excess peak shaving equipment is no longer sitting idle and Southern California Edison and Pacific Gas and Electric are basically bankrupt because California regulators do not allow a free market - i.e. passing high spot prices on to the consumer.

The paradox is that SCE and PG&E were forced to sell off 50% of their power generating facilities to companies such as Southern, Duke Energy, Reliant Energy, Williams, Dynegy, Calpine and NRG. It was felt that this would bring competition to the markets. The result is that these companies will make record profits in a "free market" while SCE and PG&E will go bankrupt with regulated retail prices. This will ultimately reduce the California power industry to the level of a third world nation with continual rolling black-outs, forced shutdown of air conditioning units by private citizens, loss of industries which consume large amounts of power because they can't pay their bills, etc.

Put the power industry back the way it was in 1990 with a modification to allow co-generation and any small power producer to sell excess power to the local monopoly. California is the 6th largest economy in the world and has an enormous direct and indirect affect of the total economy in the US. The power problem affects private citizens as well as the large companies. This is the first thing to fix to keep the country out of a recession.

- 2) Return to US gasoline, heating oil and diesel fuel specifications of 1990 and return to fungible products.

Since the early 1980s increasingly strict limits have been set by the EPA and CARB which limit the prior ability to move liquid petroleum products between regions of the country and reduced the possibility of imports when there are shortages caused by unplanned refinery shutdowns. Lead was removed from gasoline in the late 1980's, volatility limits reduced the use of butanes, aromatic content was restricted and reformulated/oxygenated gasolines were required by the mid-1990s.

All of these actions have lead to extremely complicated supply situations since they were applied selectively to various cities and regions. The problem is exacerbated by the continued need for different product properties in summer and winter. A further complication is added by the fact that refineries in Texas and Louisiana supply products to the Midwest and East which by regulation have different specifications than the Southern markets.

Quality differences for kerosene and diesel fuel reduced the fungibility of these products during the same time period. The need for these stringent controls was never verified. Revisit these regulations and relax some of the specifications to reduce the shortage situations that have arisen because of the regulations. Providing similar specifications in all regions of the country will go a long way toward eliminating local supply crises via inter-regional product transfers.

Long Term Solutions

- 3) **Reduce governmental restraints that impede the immediate installation of coal fired power generating facilities by individual local companies as well as new nuclear power plants and new refining capacity.**

No new refineries have been built for 25 years and existing refineries were shut down rather than make the massive investments required by law for environmental issues. Nuclear power was halted because of the massive delays caused by regulatory requirements. Deregulation and environmental constraints have delayed conventional power plant construction. The current crises in natural gas, power, and petroleum product shortages will continue to get worse with rising demand and no new facilities.

New coal fired power plants will violate the carbon dioxide limits – i.e. global warming – but this is a tradeoff to obtain low cost power in the short term. In the long term these plants will be phased out and replaced by nuclear and solar energy.

- 4) **Set up a national company to build nuclear power plants with a common plant design and plants operated by graduate electrical engineers.**

Nearly all of the countries in the industrial world – Japan, Taiwan, Korea, Sweden, Germany, England and France - have developed programs for the rational use of nuclear power. Follow the French model that has successfully converted the country to a nuclear power base. Obtain French technology for reprocessing nuclear waste. The reprocessing may not be as economical as using new materials; however, it is required for environmental limits.

Any arguments against nuclear power related to cost are a myth. The costly overruns of the 1970s and 1980s were a direct result of the length of time required to get approvals and not the cost of construction.

The safety issue is also a myth. No major industrial country has had a serious problem since the beginning of nuclear power. The Chernobyl problems were the same as every other facet of USSR industry. In a centrally planned economy nothing works.

Currently operating nuclear plants were all designed by different companies and are operated by people with limited understanding of the processes. Use a common design for all new plants with nuclear engineers as plant operators to add a higher level of safety to the operation. Nuclear power eliminates emissions, reduces the need for foreign hydrocarbons and improves the balance of payments.

- 5) **Install high speed electric train service in high population density areas of the US using a common technology.**

Japan, Germany and France have high speed electric rail transportation systems. France coupled their rail system to a nuclear power program. The use of rail systems would reduce the congestion at major airports as well as reduce gasoline, diesel and jet fuel use. The French model reduces emissions and reliance on foreign oil and improves the balance of payments.

Follow the models of cities such as Amsterdam and Geneva where a single terminal services air, rail and bus transportation. In all major US cities install high speed rail service between the city center and the airport as in Tokyo, London and Rome.

- 6) **Set up a national research program to reduce the cost of photovoltaic cells.**

Photovoltaic cells have come a long way since the 1960's. The cost has dropped dramatically over the last 30 years and the use of photovoltaic power is now competitive with other power generating schemes in some instances. Make an intensive effort to improve the efficiency and lower the cost of this power source.

If every private residence in the US had a roof of silicon tiles feeding power back into the grid during non-peak periods the US would meet all of the degree of freedom limits plus provide an energy source that would be totally immune from the types of problems which occur with the temporary loss of a single large facility.

Photovoltaic power and electric automobiles are the ultimate individual transportation goal and reduce both nuclear and fossil fuel power generation as well as emissions.

- 7) **Set up a government purchasing program for fleets of electric cars to be used by government employees.**

The US energy market is really a liquid fuels market. If the major automobile companies had spent as much for research on battery capacity as they have on internal combustion improvements we would have an acceptable electric automobile. We went from no where in space to the moon in 10 years. The battery operated car exists; the only drawback is a battery with a low driving range capability. Force the issue via a government purchase of a fleet of 5000 pure battery driven electric cars to be used in the Washington, DC area.

For competitive diversity buy 1000 each from 5 different automobile companies. This will allow a critical mass for the development work on battery life and range, battery changing stations and the installation of recharging facilities in parking lots and home garages. Canada and Alaska have had electrical connections in parking lots for years to keep automobile engines warm in the winter.

The ultimate goal in a 20 -30 year period is to have a large portion of the US automobile fleet battery driven and powered by a grid which is fed from large nuclear power stations and millions of individual sites producing photovoltaic power.

There is much current market spin about hybrid electric-gasoline cars. These models sometimes consider the use of hydrogen in fuel cells. Reforming natural gas and heavier liquid hydrocarbons produce hydrogen but also produce carbon dioxide – i.e. global warming. These automobiles will still require onboard liquid fuels for reforming in the vehicle or the automobiles will have to be refueled from service stations handling liquid or gaseous hydrogen. Consider this as millions of mini-Hindenburgs

- 8) **Through taxation of petroleum products and/or taxation of new vehicle purchases allow markets to penalize low mile/gallon vehicles and reward high mile/gallon vehicle purchases.**

New refinery construction is not required if demand for petroleum products is reduced. A good portion of the increase in gasoline demand is from the use of low miles per gallon SUVs. There are two methods available to restrict gasoline consumption:

- a) The most unpalatable politically is to tax gasoline consumption with rates which are equal to the European countries – i.e. \$3.00/gal total cost. Use the increased tax revenue to fund the development of a high speed rail system.
- b) Use a neutral tax approach on all new vehicle purchases. Add a tax to high gasoline consumption cars/SUVs and give a tax credit on the purchase of all high mileage cars. This will not affect anyone's standard of living. High income people still have the option of buying a luxury automobile. For anyone buying a high mile per gallon automobile the tax rebate plus lower gasoline consumption allows them to save or spend more on other consumer items which is good for the economy.

With either a or b there are obvious savings via reduction in balance of payments, reduced reliance on foreign sourced energy and reduced emissions.

- 9) **Set up a national company to construct and operate coal liquefaction and gasification plants on the US Gulf Coast using western coal reserves transported by pipe line slurry and imports. Construct similar plants in West Virginia.**

This feature is presented for two reasons:

- a) Increase the production of liquid hydrocarbon products and natural gas.
- b) Most importantly provide experience with world scale coal conversion plants which may be needed if international supplies of crude oil become unreliable.

Obtain the processing knowledge from South Africa. This piece of an energy policy violates the global warming limits but it will only be used on a massive scale if the US has lost access to major crude oil supplies in the Middle East. World scale plants are needed to allow the rapid construction of similar plants if needed later for energy security.

10) Open governmental lands to oil/gas exploration.

This will provide a reduction in foreign exchange. It will also improve our energy security. However, it does nothing for the current energy crisis which is a shortage of power plants and refineries not crude oil availability.

There has never been a shortage of crude. In fact there has always been a worldwide surplus of productive capacity. The US has a very low ratio of reserves to consumption. For maximum strategic value any crude found on federal land should be developed but shut in for the eventual use during international emergencies provided sufficient liquid fuel savings are generated by other means to reduce the balance of payments problem. Simply stated we have very small crude reserves and we should be using other nations crude and save ours for periods of shortage.

Shut in production is a much better emergency source than the SPR which is finite and quite frankly not of sufficient size to handle any major supply disruption. The major international oil companies controlled most of the oil reserves in the Middle East in the 1980s. Productive capacity was in excess worldwide as it is today. This excess capacity was used to smooth out supply variations. Unproduced oil stored in the ground with variable production rates was used to minimize expensive above ground tankage that would have been required with fixed production rates.

bb

From: [] on 01/26/2001 04:16 AM GMT

To: president@Whitehouse.GOV
cc:
Subject: Energy policy

From:
Michael Smith

[] bb

President Bush:

I appreciate you taking the lead in formulating a national energy policy with a balance between new energy production and generation and the need to conserve resources and live more simply. The previous administration listened too much to the conservationists who falsely believe we can just conserve our way out of an energy shortage. The oil fields under the Arctic National Wildlife Refuge need to be drilled but with care to do as little harm to the environment as possible. Natural gas on our nation's public and private lands need more attention. If we are going to use natural gas as a primary fuel in this country, we need to ensure a steady supply and price. At the same time, we need to once again try to increase fuel mileage standards to reduce our consumption of oil and pollute less. I trust that your administration will have the courage to intiate these much needed reforms. Thank you for your time.

Sincerely,

Michael Smith

Dr. William H. Hannum

b6

26 January 2001

The Honorable Spencer Abraham, Secretary
U. S. Department of Energy
1000 Independence Avenue, S. W.
Washington, D. C. 20585

Dear Mr. Secretary:

Congratulations on your selection as Secretary of the Department of Energy. You have a great challenge, coming in after many years of political correctness masquerading as energy policy. It is perhaps fortunate that the current California electricity problems are leading to an open discussion of the options and challenges.

I have recently retired from a 40+ year career in energy, which included some 25 years with DOE and its predecessor agencies. Energy is a topic that I feel strongly about, and where I claim some expertise.

I am enclosing a brief essay, in hopes that this will contribute to a constructive discussion. You may use this essay and its ideas in any way you see fit, with or without attribution.

With my best wishes.

Yours truly,



cc: Senator Peter Fitzgerald
Senator Richard Durbin
Representative Judy Biggert

Energy Policy

An Essay

William H. Hannum, PhD

Introduction

Energy is the engine that drives the economy. A healthy economy results from the constructive application of material, energy and intellect. This essay discusses the current state of the energy sector in the U. S. (and by extension, in the industrial world). Prior to the 1950s, energy was largely a local matter, except for the transport of coal, largely for the production of steel, and the distribution of refined petroleum products for transportation.

A variety of competing forces in the 1950s and 1960s revolutionized the energy market, both in supply and consumption. Prior to that time, coal was essentially a monopoly industrial-energy source. John L. Lewis and his United Mineworkers Union set out to take advantage of this monopoly. But then, gas pipe lines were built from Texas to the East, and coal was no longer used for residential and commercial heating. The response by the utilities was to turn to nuclear power, depriving coal of much of that market. On the world market, the Suez crisis cut off Mid-east oil to Western Europe until super-tankers were built to go around Africa, and consequently anywhere in the world. Suddenly, oil became available as a world-wide energy resource. Coal responded by retreating to its role as an active competitor. The world energy market had become, in the terms of a classic British Parliamentary study, a "four-fuels" economy: gas, oil, coal and nuclear.

The next major evolution in the world energy market was the realization by Sheik Yamani that Mid-east oil was in fact an essential product being priced by consumers, not by the market. His MIT economics education suggested that he could do otherwise. OPEC was formed, and oil went from \$2 per barrel to \$20 overnight, and we had the first of the several oil crises of the 1970s. The U. S. government was called on for the first time to formulate a national energy strategy. The result was "underwhelming," and we had our first of many non-policies.

So what are the prospects now? The situation can be analyzed in term of the various energy supply components.

Coal

Coal is an apparent and obvious energy resource. The resource is abundant, both domestically and world-wide. The environmental implications, both in mining and in burning, strongly suggest that well controlled central-station uses (electrical generation or industrial heat) are the proper application of coal, but it would be foolish to look to this as a monopoly energy source for such application. The one environmental consequence which is not easily addressed is CO-2

release from combustion, whether global warming ultimately proves to be a serious concern or not.

Oil

Oil is perhaps nature's most valuable energy asset because of its high energy content and transportability. Beyond the question of spending history's inventory of this resource in a few generations by the rich, the major difficulty with this resource is its geographic distribution. The U.S. has already largely consumed its allocation of oil, and there is a serious price that will be paid for relying on the resources located elsewhere. Our massive dependence on imported oil is clearly destabilizing the world balance of power, and this destabilization will only become more and more serious unless oil use patterns are rapidly reversed.

Oil should be used where the combination of energy content and transportability are best used, such as transportation. Central station use should be used with caution (this does appear to be a reasonable use of certain residual crude oils).

Natural Gas

Natural gas is arguably at least as valuable as oil, in that burning is easier and the particulate release is negligible. Distributed consumption is the major advantage of this source, and the application should be focused there, such as in home heating. The recent "electricity price crisis" in California and "heating cost crisis" in New England are clear evidence of the folly of excess reliance on natural gas for bulk consumption such as for electricity generation. While importing natural gas from Canada (where much of our natural gas now originates) is less frightening than importation of oil from the Mid-east, it still has its risks.

Nuclear

Nuclear power for electricity had its hey-day in the 1960s, but fell out of favor because of several strategic errors, some by the government and some by industrial firms. On the industrial side (both manufacturers and utilities), nuclear power plants were sold to utilities which did not have the competence and management depth to properly operate these plants; the complexity of the plants was obscured; and the sales clearly outpaced the understanding of safety concerns. While the only people hurt by the Three Mile Island accident were the share-holders, this incident clearly demonstrated the risks were underestimated by the operators and overestimated by the regulators. The technology has now largely caught up, and utility deregulation has led to an almost total consolidation in the industry, resolving concerns over competence and depth of management in the U. S.

On the government side, the major error was in accepting responsibility for "closing the fuel-cycle;" i.e., resolving what to do with spent nuclear fuel, and how to dispose of nuclear wastes. The government did not deliver on either of these. A minor diversion is required here, before returning to projections as to the appropriate role for nuclear power. One of the key mantras of the nuclear power advocates is to maintain a pure separation between civilian and military

applications of nuclear technology. This is unrealistic. Uranium resources were developed first for military needs; enrichment technologies and facilities were developed for the military. Much of the fuel and material technology was developed for military applications. It was also assumed (incorrectly) that the technology for closing of the fuel cycle was available based on weapons processing technology, and that arrangements for disposal of nuclear wastes would be put in place to serve the needs of military programs. This unfulfilled interdependence has resulted in much finger pointing and inaction.

So what is the actual current situation. Closing the fuel cycle by recycling is clearly feasible, but it appears to most analysts to make nuclear power only marginally competitive economically. There is concern over "high-level wastes" generated by current recycle technologies, but this is nonsense. The DOE West Valley Demonstration Project showed that reducing recycle wastes to a permanently stable waste form is straightforward. The fact that DOE has been unable to satisfactorily process such wastes from comparable processing at the defense sites says more about DOE management than about the underlying technology. This is discussed further under "DOE Management of Energy Technology Development," below.

Given the current glut of uranium caused by the end of the cold-war weapons programs, there is no rush to recycle. We should endorse the de-facto moratorium on fuel recycling, and support a directed program to develop advanced recycle technologies, so as to have these available within a decade, when we will have worked through the current glut of enriched uranium.

As for waste disposal, this is a highly politicized issue which overlooks the facts of the situation. There are three risk phases for nuclear wastes. For the first 10 years or so, short lived fission products cause a direct radiation hazard, and the high level wastes need to be secured for such a period. This is perfectly straightforward, and is currently practiced by all nuclear applications. Following this period, there remain two residual risks, one of a few hundred years and one semi-permanent. The shorter period risk (Cs, Sr) is readily managed by any of several technologies such as transforming the wastes into a glass form. The long term hazard is comparable in magnitude to that posed by the original ore, so the challenge is to handle this material in a fashion which does not significantly increase the pre-existing risk occurring in nature. Again, there is no crisis here, and the policy should be to stabilize wastes, and safely store these wastes for the first two hazard cycles, either passively or actively. The residual risk is so modest that it can safely be left to future generations to find a convenient remedy.

Proliferation

One of the most contentious concerns raised about nuclear power, particularly if a tie between civilian and military applications is acknowledged, is the concern over proliferation of nuclear weapons. This concern is real, but has almost no bearing on whether nuclear power should be deployed or not. It is pointless to observe that the issue would not exist if nuclear weapons and the associated technologies had never been developed.

There are two practical types of nuclear weapons, one based on enriched uranium, the other based on plutonium. The technologies for making a weapon with enriched uranium and that for

enriching uranium are widely known and feasible. An effective inspection program, such as is administered by the IAEA, is necessary, quite separate from whether or not there is civilian nuclear power. It is arguably easier to inspect in the presence of a civilian program.

To make a plutonium weapon, other than as an isolated terrorist device, requires highly complex and sophisticated equipment, facilities, and technology. Such plutonium as exists in any realistic civilian fuel cycle makes no significant contribution to making a plutonium weapon. There are vast quantities of plutonium left over from weapons programs. Safeguards exist, and need to be kept current based on military weapons materials and programs. A civilian nuclear power program does not change this requirement either in type or magnitude.

Other Technologies (e.g., Solar, wind)

There are an number of other energy sources which deserve consideration as niche contributors, but none of these other than hydro-electricity constitute significant substitutes for the bulk energy sources discussed above.

Solar hot water is effective in many parts of the country, but attempts to promote this in the Carter era failed to make much of an inroad. This still makes sense and should be encouraged as a niche contribution.

Solar electric, on the other hand, is clearly a highly specialized application. Claims of the promoters notwithstanding, this technology provides no substitute for bulk sources discussed above.

Wind power, likewise, may have a niche, but there seems to be little basis for continuing the major subsidies provided to this technology. Where this makes economic sense it will be used, but its potential is limited.

Hydro-power is a proven contributor, but in the U. S., it is generally considered that most of the environmentally acceptable sites have already been used. There remains a significant potential role for low-head hydro-power.

Conservation

Some argue that conservation is the best response to energy supply concerns. To fairly appreciate this approach, it is necessary to go beyond the politicized terminology. "Conservation" means two quite different things: either improved efficiency, or doing without. Doing without is not easily endorsed.

There can be no argument with improved efficiency. Perhaps the most egregious inefficiencies today is the use of natural gas for electricity, where the net efficiency is about 40%, whereas for home heating, the efficiency is essentially 100%. On auto gas mileage, considerable improvements have been made, and further incremental improvement is feasible, but some of the more extreme "improvements" come at the cost of safety, comfort and utility. There are

alternatives, such as fuel-cell propulsion technologies which have significant promise. The electric automobile is attractive, but the infrastructure implications are substantial.

A much more effective transportation initiative would be to electrify the U. S. rail system. Massive federal funds are used to provide the interstate highway system, perhaps one of the most significant infrastructure developments of the twentieth century. A federally organized program to electrify the rail system would open up vast efficiency opportunities. This is an area where the U. S. is far behind all other industrialized countries. This would also provide substantial opportunities for substitution of other mass fuels for oil, and would encourage freight to move on the rails rather than on the highways.

DOE Management of Energy Technology Development

DOE has, since its inception, shown itself to be incompetent in managing energy technology development. DOE's stewardship has been based on political prerogatives and jobs for constituents. The direct DOE internal structure has gone from fairly direct technical management, or at least goal setting and evaluation, to a system of hiring contractors to develop programs, and other contractors to manage contractors, who in turn manage other contractors. Each project is now overlaid with layer after layer of administrators.

The contractors at the end of the chain have responded, more often than not, by pursuing job security without reference to achievement of any rationally defined objective, because there have been none. As noted above, even high importance tasks such as stabilizing high level wastes at nuclear weapons sites have taken a back seat to the assurance of stable budgets and staffing.

A house cleaning to rid the Department of ideologues, and the termination of the multilayered oversight and management contractors will permit the pursuit of an objective oriented energy policy, but even this will be meaningless without the development of a rational, sensible plan.

Conclusions and Recommendations

Options to affect consumption are limited. It is clear that there is no means of substantially reducing consumption in the short term without serious economic impact. Continued marginal improvements in efficiency can be made, but there seems to be few other opportunities.

Rather than to abandon hope, dramatic initiatives in the near term should be undertaken, even though their impact will not be seen for some years. During the next decade, a major initiative should be undertaken to move away from oil consumption by electrifying the railroad system, and major efforts to discourage bulk burning of natural gas. This, coupled with corresponding supply initiatives, will re-stabilize the world energy situation.

In the long term, technologies which could offer other displacements, such as fuel-cells for automobiles, should be developed.

On the supply side, a return to promotion of solar heating would also offer some short-term

relief. To have a significant impact in the near term, a concerted program to build current-design nuclear power plants is necessary. Designs pre-approved by regulators are available. Continued research on clean coal will allow continued use of this source. This combination will allow electricity to replace oil, as implied by the proposed railroad electrification and longer term automotive fuel-cell deployment.

For the longer term, improved nuclear recycle technologies should be pursued. Those responsible (and funded) for stabilizing existing weapons high-level wastes should be expected to be more results oriented. While research on geologic disposal of nuclear wastes should continue, there is no evident basis for urgency for such disposal. These initiatives will allow long term growth in energy supplies, even should global warming require limits on burning of fossil fuels.

Research on the various niche technologies should be continued, but only at a level commensurate with their probable contribution, and with due consideration of their likelihood of success.

January 12, 2001

2001-002339 1/29 P 4:40

b6

002339

Dr. William H. Hannum

()

26 January 2001

The Honorable Spencer Abraham, Secretary
U. S. Department of Energy
1000 Independence Avenue, S. W.
Washington, D. C. 20585

Dear Mr. Secretary:

Congratulations on your selection as Secretary of the Department of Energy. You have a great challenge, coming in after many years of political correctness masquerading as energy policy. It is perhaps fortunate that the current California electricity problems are leading to an open discussion of the options and challenges.

I have recently retired from a 40+ year career in energy, which included some 25 years with DOE and its predecessor agencies. Energy is a topic that I feel strongly about, and where I claim some expertise.

I am enclosing a brief essay, in hopes that this will contribute to a constructive discussion. You may use this essay and its ideas in any way you see fit, with or without attribution.

With my best wishes.

Yours truly,

William H. Hannum

cc: Senator Peter Fitzgerald
Senator Richard Durbin
Representative Judy Biggert

29521

Energy Policy

An Essay

William H. Hannum, PhD

Introduction

Energy is the engine that drives the economy. A healthy economy results from the constructive application of material, energy and intellect. This essay discusses the current state of the energy sector in the U. S. (and by extension, in the industrial world). Prior to the 1950s, energy was largely a local matter, except for the transport of coal, largely for the production of steel, and the distribution of refined petroleum products for transportation.

A variety of competing forces in the 1950s and 1960s revolutionized the energy market, both in supply and consumption. Prior to that time, coal was essentially a monopoly industrial-energy source. John L. Lewis and his United Mineworkers Union set out to take advantage of this monopoly. But then, gas pipe lines were built from Texas to the East, and coal was no longer used for residential and commercial heating. The response by the utilities was to turn to nuclear power, depriving coal of much of that market. On the world market, the Suez crisis cut off Mid-east oil to Western Europe until super-tankers were built to go around Africa, and consequently anywhere in the world. Suddenly, oil became available as a world-wide energy resource. Coal responded by retreating to its role as an active competitor. The world energy market had become, in the terms of a classic British Parliamentary study, a "four-fuels" economy: gas, oil, coal and nuclear.

The next major evolution in the world energy market was the realization by Sheik Yamani that Mid-east oil was in fact an essential product being priced by consumers, not by the market. His MIT economics education suggested that he could do otherwise. OPEC was formed, and oil went from \$2 per barrel to \$20 overnight, and we had the first of the several oil crises of the 1970s. The U. S. government was called on for the first time to formulate a national energy strategy. The result was "underwhelming," and we had our first of many non-policies.

So what are the prospects now? The situation can be analyzed in term of the various energy supply components.

Coal

Coal is an apparent and obvious energy resource. The resource is abundant, both domestically and world-wide. The environmental implications, both in mining and in burning, strongly suggest that well controlled central-station uses (electrical generation or industrial heat) are the proper application of coal, but it would be foolish to look to this as a monopoly energy source for such application. The one environmental consequence which is not easily addressed is CO-2

release from combustion, whether global warming ultimately proves to be a serious concern or not.

Oil

Oil is perhaps nature's most valuable energy asset because of its high energy content and transportability. Beyond the question of spending history's inventory of this resource in a few generations by the rich, the major difficulty with this resource is its geographic distribution. The U.S. has already largely consumed its allocation of oil, and there is a serious price that will be paid for relying on the resources located elsewhere. Our massive dependence on imported oil is clearly destabilizing the world balance of power, and this destabilization will only become more and more serious unless oil use patterns are rapidly reversed.

Oil should be used where the combination of energy content and transportability are best used, such as transportation. Central station use should be used with caution (this does appear to be a reasonable use of certain residual crude oils).

Natural Gas

Natural gas is arguably at least as valuable as oil, in that burning is easier and the particulate release is negligible. Distributed consumption is the major advantage of this source, and the application should be focused there, such as in home heating. The recent "electricity price crisis" in California and "heating cost crisis" in New England are clear evidence of the folly of excess reliance on natural gas for bulk consumption such as for electricity generation. While importing natural gas from Canada (where much of our natural gas now originates) is less frightening than importation of oil from the Mid-east, it still has its risks.

Nuclear

Nuclear power for electricity had its hey-day in the 1960s, but fell out of favor because of several strategic errors, some by the government and some by industrial firms. On the industrial side (both manufacturers and utilities), nuclear power plants were sold to utilities which did not have the competence and management depth to properly operate these plants; the complexity of the plants was obscured; and the sales clearly outpaced the understanding of safety concerns. While the only people hurt by the Three Mile Island accident were the share-holders, this incident clearly demonstrated the risks were underestimated by the operators and overestimated by the regulators. The technology has now largely caught up, and utility deregulation has led to an almost total consolidation in the industry, resolving concerns over competence and depth of management in the U. S.

On the government side, the major error was in accepting responsibility for "closing the fuel-cycle;" i.e., resolving what to do with spent nuclear fuel, and how to dispose of nuclear wastes. The government did not deliver on either of these. A minor diversion is required here, before returning to projections as to the appropriate role for nuclear power. One of the key mantras of the nuclear power advocates is to maintain a pure separation between civilian and military

applications of nuclear technology. This is unrealistic. Uranium resources were developed first for military needs; enrichment technologies and facilities were developed for the military. Much of the fuel and material technology was developed for military applications. It was also assumed (incorrectly) that the technology for closing of the fuel cycle was available based on weapons processing technology, and that arrangements for disposal of nuclear wastes would be put in place to serve the needs of military programs. This unfulfilled interdependence has resulted in much finger pointing and inaction.

So what is the actual current situation. Closing the fuel cycle by recycling is clearly feasible, but it appears to most analysts to make nuclear power only marginally competitive economically. There is concern over "high-level wastes" generated by current recycle technologies, but this is nonsense. The DOE West Valley Demonstration Project showed that reducing recycle wastes to a permanently stable waste form is straightforward. The fact that DOE has been unable to satisfactorily process such wastes from comparable processing at the defense sites says more about DOE management than about the underlying technology. This is discussed further under "DOE Management of Energy Technology Development," below.

Given the current glut of uranium caused by the end of the cold-war weapons programs, there is no rush to recycle. We should endorse the de-facto moratorium on fuel recycling, and support a directed program to develop advanced recycle technologies, so as to have these available within a decade, when we will have worked through the current glut of enriched uranium.

As for waste disposal, this is a highly politicized issue which overlooks the facts of the situation. There are three risk phases for nuclear wastes. For the first 10 years or so, short lived fission products cause a direct radiation hazard, and the high level wastes need to be secured for such a period. This is perfectly straightforward, and is currently practiced by all nuclear applications. Following this period, there remain two residual risks, one of a few hundred years and one semi-permanent. The shorter period risk (Cs, Sr) is readily managed by any of several technologies such as transforming the wastes into a glass form. The long term hazard is comparable in magnitude to that posed by the original ore, so the challenge is to handle this material in a fashion which does not significantly increase the pre-existing risk occurring in nature. Again, there is no crisis here, and the policy should be to stabilize wastes, and safely store these wastes for the first two hazard cycles, either passively or actively. The residual risk is so modest that it can safely be left to future generations to find a convenient remedy.

Proliferation

One of the most contentious concerns raised about nuclear power, particularly if a tie between civilian and military applications is acknowledged, is the concern over proliferation of nuclear weapons. This concern is real, but has almost no bearing on whether nuclear power should be deployed or not. It is pointless to observe that the issue would not exist if nuclear weapons and the associated technologies had never been developed.

There are two practical types of nuclear weapons, one based on enriched uranium, the other based on plutonium. The technologies for making a weapon with enriched uranium and that for

enriching uranium are widely known and feasible. An effective inspection program, such as is administered by the IAEA, is necessary, quite separate from whether or not there is civilian nuclear power. It is arguably easier to inspect in the presence of a civilian program.

To make a plutonium weapon, other than as an isolated terrorist device, requires highly complex and sophisticated equipment, facilities, and technology. Such plutonium as exists in any realistic civilian fuel cycle makes no significant contribution to making a plutonium weapon. There are vast quantities of plutonium left over from weapons programs. Safeguards exist, and need to be kept current based on military weapons materials and programs. A civilian nuclear power program does not change this requirement either in type or magnitude.

Other Technologies (e.g., Solar, wind)

There are an number of other energy sources which deserve consideration as niche contributors, but none of these other than hydro-electricity constitute significant substitutes for the bulk energy sources discussed above.

Solar hot water is effective in many parts of the country, but attempts to promote this in the Carter era failed to make much of an inroad. This still makes sense and should be encouraged as a niche contribution.

Solar electric, on the other hand, is clearly a highly specialized application. Claims of the promoters notwithstanding, this technology provides no substitute for bulk sources discussed above.

Wind power, likewise, may have a niche, but there seems to be little basis for continuing the major subsidies provided to this technology. Where this makes economic sense it will be used, but its potential is limited.

Hydro-power is a proven contributor, but in the U. S., it is generally considered that most of the environmentally acceptable sites have already been used. There remains a significant potential role for low-head hydro-power.

Conservation

Some argue that conservation is the best response to energy supply concerns. To fairly appreciate this approach, it is necessary to go beyond the politicized terminology. "Conservation" means two quite different things: either improved efficiency, or doing without. Doing without is not easily endorsed.

There can be no argument with improved efficiency. Perhaps the most egregious inefficiencies today is the use of natural gas for electricity, where the net efficiency is about 40%, whereas for home heating, the efficiency is essentially 100%. On auto gas mileage, considerable improvements have been made, and further incremental improvement is feasible, but some of the more extreme "improvements" come at the cost of safety, comfort and utility. There are

alternatives, such as fuel-cell propulsion technologies which have significant promise. The electric automobile is attractive, but the infrastructure implications are substantial.

A much more effective transportation initiative would be to electrify the U. S. rail system. Massive federal funds are used to provide the interstate highway system, perhaps one of the most significant infrastructure developments of the twentieth century. A federally organized program to electrify the rail system would open up vast efficiency opportunities. This is an area where the U. S. is far behind all other industrialized countries. This would also provide substantial opportunities for substitution of other mass fuels for oil, and would encourage freight to move on the rails rather than on the highways.

DOE Management of Energy Technology Development

DOE has, since its inception, shown itself to be incompetent in managing energy technology development. DOE's stewardship has been based on political prerogatives and jobs for constituents. The direct DOE internal structure has gone from fairly direct technical management, or at least goal setting and evaluation, to a system of hiring contractors to develop programs, and other contractors to manage contractors, who in turn manage other contractors. Each project is now overlaid with layer after layer of administrators.

The contractors at the end of the chain have responded, more often than not, by pursuing job security without reference to achievement of any rationally defined objective, because there have been none. As noted above, even high importance tasks such as stabilizing high level wastes at nuclear weapons sites have taken a back seat to the assurance of stable budgets and staffing.

A house cleaning to rid the Department of ideologues, and the termination of the multilayered oversight and management contractors will permit the pursuit of an objective oriented energy policy, but even this will be meaningless without the development of a rational, sensible plan.

Conclusions and Recommendations

Options to affect consumption are limited. It is clear that there is no means of substantially reducing consumption in the short term without serious economic impact. Continued marginal improvements in efficiency can be made, but there seems to be few other opportunities.

Rather than to abandon hope, dramatic initiatives in the near term should be undertaken, even though their impact will not be seen for some years. During the next decade, a major initiative should be undertaken to move away from oil consumption by electrifying the railroad system, and major efforts to discourage bulk burning of natural gas. This, coupled with corresponding supply initiatives, will re-stabilize the world energy situation.

In the long term, technologies which could offer other displacements, such as fuel-cells for automobiles, should be developed.

On the supply side, a return to promotion of solar heating would also offer some short-term

relief. To have a significant impact in the near term, a concerted program to build current-design nuclear power plants is necessary. Designs pre-approved by regulators are available. Continued research on clean coal will allow continued use of this source. This combination will allow electricity to replace oil, as implied by the proposed railroad electrification and longer term automotive fuel-cell deployment.

For the longer term, improved nuclear recycle technologies should be pursued. Those responsible (and funded) for stabilizing existing weapons high-level wastes should be expected to be more results oriented. While research on geologic disposal of nuclear wastes should continue, there is no evident basis for urgency for such disposal. These initiatives will allow long term growth in energy supplies, even should global warming require limits on burning of fossil fuels.

Research on the various niche technologies should be continued, but only at a level commensurate with their probable contribution, and with due consideration of their likelihood of success.

January 12, 2001

b6

I. Arthur Hoekstra, PE
[]

US Vice President Dick Cheney
Office of Vice President
Old Executive Office Building
Washington, DC 20501

January 28, 2001

Dear Vice President Cheney,

Re: Energy conservation

I watched you during the Meet the Press program on January 28, 2001 and I applaud you for a good performance.

I noticed that you are going to generate an energy policy, which will cover all sources of energy: gas, oil, coal, nuclear etc. However you didn't mention garbage, which has approximately the same heating value as coal, and it is composed mainly of paper and plastics which are innocuous materials. It offers a tremendous source of energy that we mainly waste.

Consider that garbage is an inexhaustible and replaceable energy supply. Typically the generator of the waste pays the cost of incineration. Any power obtained reduces the cost and likewise, any heat recovered reduces the cost. When I hear today's news about the crisis in CA, I think about how it would be helped if they used my idea to recover heat and water from garbage incineration. This problem exists everywhere in the US.

My method of cleaning the flue gas is exactly the same as occurs in nature where the contaminants are removed by a water wash in the form of condensation and rain. In my process the process occurs much faster and the contaminants are confined and collected for proper disposal rather than allowing them to be dispersed over the landscape. This is why my system is better than any other for both recovering the heat and controlling pollution.

I hope the US energy department can find my files, which will further explain my design for energy recovery.

Yours truly,



I. Arthur Hoekstra

Cc Thomas Dolan
Marc Coppola
Governor Pataki

Released in
Liberty

United States Patent [19]

Hoekstra

[11] Patent Number: 4,491,093

[45] Date of Patent: Jan. 1, 1985

[34] ENERGY AND WATER RECOVERY FROM FLUE GASES

[76] Inventor: L. Arthur Hoekstra, 906 Woodlyn Dr. N., Cincinnati, Ohio 45230

[21] Appl. No.: 593,484

[22] Filed: Mar. 26, 1984

[51] Int. Cl. F22D 1/02

[52] U.S. Cl. 122/420; 110/215; 122/1 C; 122/451 S

[58] Field of Search 122/420, 421, 412, 431 S, 122/1 R, 1 C, 31 R, 5.5 A; 110/215

[56] References Cited

U.S. PATENT DOCUMENTS

- 4,173,949 11/1979 Rothe 122/421
- 4,398,501 8/1983 Mischani 122/1 R
- 4,436,057 3/1984 Cross et al. 110/215 X
- 4,445,325 5/1984 Truss et al. 122/451 B X

Primary Examiner—Edward G. Favors
Attorney, Agent, or Firm—Diller, Ramik & Wight

[57] ABSTRACT

Energy and water are recovered from flue gases by cooling them to a temperature sufficiently below the acid dew point temperature by contact with an aqueous stream so as to recover the sensible heat and to reduce the water content of the flue gases by about 50%. The water by which the aqueous stream is enriched is subsequently flashed off to cool the stream back to its original temperature and the water vapor is then compressed to generate a higher temperature vapor stream which is condensed to recover the water and extract heat. The aqueous stream is continuously enriched with material such as calcium carbonate to control the pH sufficiently as to avoid substantial corrosion due to acidic gases removed from the flue gases and the aqueous stream is purged continuously or periodically to remove compounds such as chlorides, calcium sulphates, and fly ash solids picked up from the flue gases. The system may be operated in two stage fashion in which separate aqueous streams are employed to cool the flue gases in two serial stages.

9 Claims, 5 Drawing Figures

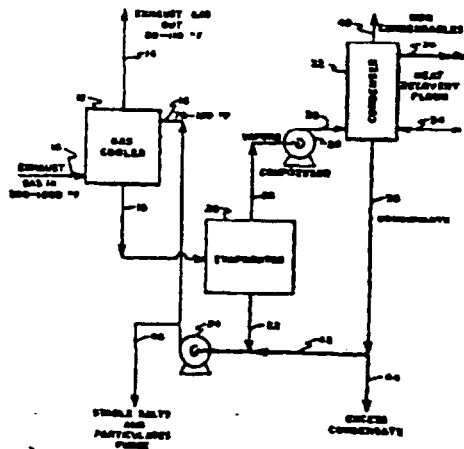

004049 2/12/01 9:53a

b6

Dear Energy secretary, Spencer Abraham:

1/28/2001

The purpose of this letter is to explain my concerns for our Federal Government's lack of a comprehensive Energy Policy. Twenty-five years ago during the oil embargo which is known as the 1973-75 energy crisis the government promised to put to use the variety of forms of energy and also to put primary emphasis on the development of solar energy, coal and alternative fuels such as renewable fuels. Twenty-five years later the government has failed to accomplish this goal.

You would think with the development of computer technology during this same time that somehow an energy policy would have been developed. Only one of the four presidents holding office during this time has done anything. Instead of an energy policy being created, President Jimmy Carter created The U.S. Department of Energy (DOE) in October of 1977. I understand that you are the new Secretary of Energy.

It seems that instead of helping the situation the government has put the brakes on any development of our natural resources, especially oil and coal. I believe the environmentalist have done the country a great disservice by not realizing that you can develop oil and coal and still not harm the environment. If the search for alternative energy had been a priority as the government promised then we would not be in the present situation. OPEC has this country in a precarious situation. We went to war in 1991 to help Kuwait over oil and now ten years later we are at the mercy of OPEC.

When this country experienced the 1973-75 energy crises OPEC had been formed for about 13 years now, this country was only dependent on foreign oil for about 35% of its yearly consumption. Today this nation is dependent on foreign oil for almost 65% of its yearly consumption. California is a good example of what could happen to the rest of the United States if we do not relax some of our policies on the saving the environment. California is now having blackouts for failure to build any new electrical generating plants. The problem is that one of the effects of the electrical power being cut off is the pump that pumps the oil is also shut off and the effect is a shortage of fuel for automobiles etc.

Mr. Abraham it is obvious that without an energy policy we will have economic failure similar to that experienced during the late 70's or greater and for our country to continue to grow we must have a source of oil other than that produced by foreign nations. Our economic industrial complex depends on oil for its survival.

29530

I believe that you as the new Secretary of Energy can have a great influence on the new President and Congress to develop an energy policy. May I suggest that you gather together all the best and most knowledgeable people that deal with energy in all forms. With this forum develop practical ideas for the development of and energy policy covering exploration of renewable energy sources as well as fossil fuels and also a way to stop our dependence on foreign oil.



I have confidence in you as our new Secretary of Energy and the future of our country that some form of energy policy will come from this new administration.

Thank you, for reading my letter and I hope to hear from you regarding your work on an energy policy and where you stand on this issue.

Sincerely,

Ashleigh Turner

Ashleigh Turner

  *bs*

[] 06
2001-002289 1/29 P 2:30

002289

James P. Langan [] 06

January 28, 2001

Mr. Spencer Abraham, Secretary
U.S. Department of Energy
Mail Stop 7E-079
1000 Independence Avenue, SW
Washington, DC 20585

Dear Secretary Abraham,

I wrote the attached dissertation on U.S. Energy policy November 2, 2000 to identify and highlight key flaws implemented by your predecessor, Secretary Richardson. This dissertation was reviewed by numerous colleagues and political acquaintances whom I consider experts in power generation and its associated technologies. By an overwhelming majority my colleagues have encouraged me to present to you a copy of my dissertation.

In your new position as Energy Secretary I know and realize that you are extremely busy. However, with a moment of your time, I must highlight three crucial facts from my research:

1. Renewable energy sources will only make up 2% of gross electric generation by the years 2004, and have an average cost of 24 cents (up to 32 cents) per kilo-watt hour (dissertation Charts 2 & 3)
2. Following the path left by Secretary Richardson we will have national electric shortage of 24% by year 2004/05 (Chart 3)
3. Starting or restarting existing nuclear power plants owned by the U.S. government and private utilities will curtail this shortage for 35-50 years.

After years of research into electric power generation technology I fully understand and realize the complexity and importance energy and how these issues relate to U.S. interests. I endorse an energy policy based on a spectrum of available technology e.g. coal, nuclear, hydro, and renewable fuel sources, thus lowering the demand for natural gas and oil. This policy will enable all US citizens to comfortably afford their electricity, lower home heating costs (via less competition for gas & oil), and yield enough time to research and develop new long-term permanent high-energy source (potentially fusion) for our future electric demands.

[

] b6

903 P02

JAN 29 '01 13:35

Secretary Abraham
Page 2 of 2

b6

I congratulate you on your new appointment as Energy Secretary and I sincerely hope that your efforts are appreciated and supported by all Americans. Although I don't have a political resumé, I have a long history of regulatory and industrial research in power generation. I would appreciate your consideration for an appointment to your Secretary of Energy Advisory Board. I will be soon publishing a new article on the US DOE/Russian HEU agreement and its impact on the US Economy, National Security, and DOE reputation. I am willing to travel to Washington at my own expense should you have any questions or require further information. I may be contacted at my home [b6] or work (651)430-8470. You and others in the Bush administration are truly inspiring to many, many Americans.

Sincerely,

James P. Langan

29533

"Energy, A New Direction"

James P. Langan

11-2-00

Introduction

This dissertation discusses serious flaws in current United States (US) energy policy set forth by the current US Department of Energy (DOE) and the Clinton/Gore administration. It is not an intention of this document to release secured or classified information regarding US Strategic Defense Initiative or projects administered by the Defense Advanced Research Projects Administration (DARPA) in its discussions relating to National Security. My additional comments and opinions herein are solely based on public declarations of the Clinton/Gore administration and DOE secretaries Ms. Hazel O'Leary (Jan 93 – Mar 97), Mr. Fredrico F. Pe-a (Mar 97 – Aug 98), and Mr. Bill Richardson (Aug 98 – Present). Reader questions and comments may be directed to James P. Langan, 13186 15th Street South, Afton, MN 55001, email jim.langan@dyn-eng.com. Subsequent research into DOE policy and National Security infringement is being conducted and will be the subject of future publication(s).

Background

During the past 10 years the United States has seen extraordinarily low oil and natural gas prices which have fueled one of the largest booms in our economy in modern history. The reason to me is obvious, the Gulf War. At the conclusion of the Gulf War in 1991 OPEC was in political shambles. Without a unified OPEC, oil was sold at record low prices. Saudi Arabia and Kuwait promised to provide for a significant length of time (approximately 10 years), oil at a reduced price to the US for our participation in their protection and liberation from Iraq in

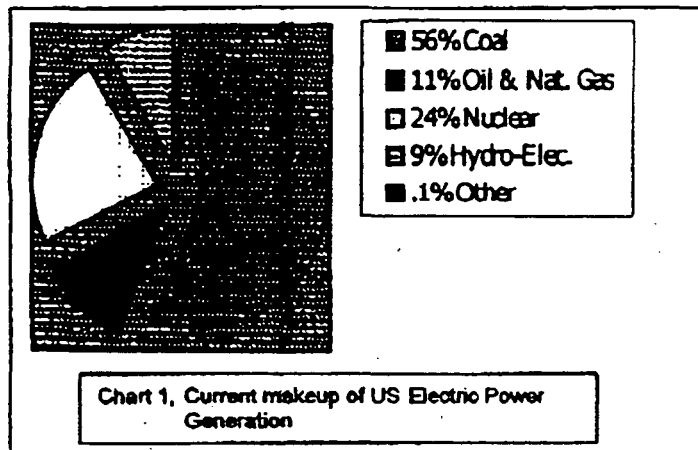

1990 and 1991. This time has now passed and OPEC has reunited. Once again OPEC is demonstrating its reign as the world oil producer, causing widespread shortages and sharp price increases. This has had a dramatic impact on the US economy by causing as shown in a 70% rise in gasoline prices, a 330 point drop in the DOW on October 13, 2000, and other economic problems yet to come. Because of the current administrations complacency, we are still as dependant on foreign oil as ever (actually more so).

The Clinton/Gore administration has systematically hindered the effectiveness of Department of Energy by destroying its research base, its energy policy, and National Laboratories strategic initiatives.

[] b6

The Present

Primary electric power generation technology utilized is: 1) Coal 56%, 2) Oil & Natural Gas 11%, 3) Nuclear 24%, and Hydro-electricity 9%. Other forms of electric generation (wind, solar, and geothermal) comprise .1% of the total electric power generation. This yields a combined generating capacity is 3,785 billion kilowatt-hours (kWh) of electricity in year 2000. The breakdown of domestic electric generation is graphically presented in chart 1.

Electric power generation costs utilizing coal, nuclear, hydro, oil & gas, and other (i.e. wind, solar, geothermal etc...) are: (coal) 3.5 cents/kWh, (nuclear) 4.3 cents/kWh, (hydro) 3.0 cents/kWh (oil) 6.5 cents/kWh, (NG)6.5/kWh, and (other) 28 - 43 cents/kWh, yielding a weighted average of 4.01 cents per kWh. Shown graphically in Chart 2.

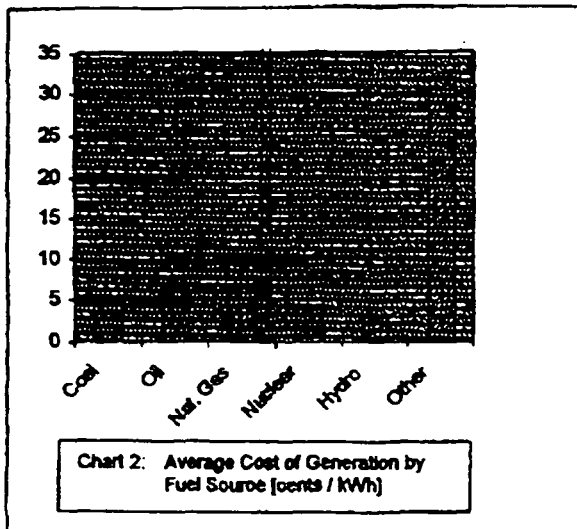

Minimal electric power shortages have occurred in year 2000. The impact of these shortages has caused utilities to reduce their load. Primarily this load reduction has come from businesses and other large electric consumers to voluntarily reduce their use of electricity during peak times. For the most part year 2000 has seen few problems related to energy shortages.

Energy Future Under Current DOE Leadership

Currently, the DOE is targeting coal, nuclear and hydroelectric generation sources to be reduced by 20%, 50% and 3% respectively by

2004. These numbers are based on current and future DOE policy statements and Gore/Lieberman campaign statements.

The fact remains that there are no other viable energy sources to make up for reductions in

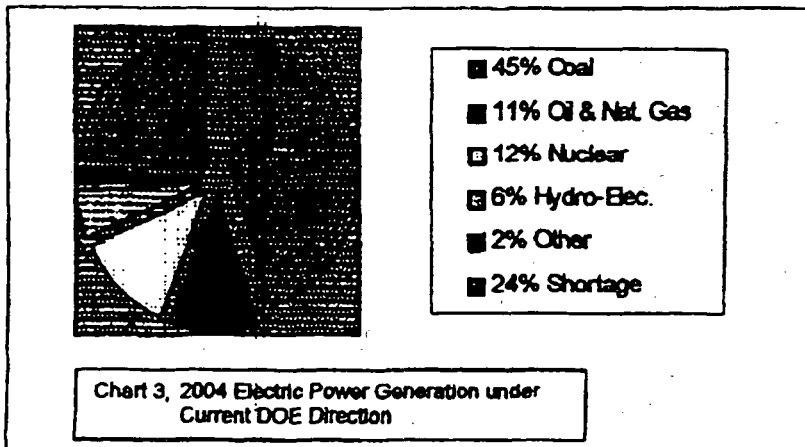

coal, nuclear and hydroelectric power generation. The DOE admits that unconventional electric sources e.g. wind, solar, and geothermal, will only grow to a maximum generation capacity of 2% by 2004. This creates a shortage of electric generation of up to 24%.

Currently, there are four possible solutions to a US

C

Jb6

energy shortage. These solutions are: acquire electricity from another country (i.e. Mexico or Canada); generate the shortage from a different source; "live with it"; or further utilize an existing source of power generation (i.e. coal, nuclear, oil, natural gas).

We currently purchase a significant amount of energy from Canada (electricity and natural gas), this power is mostly acquired during high usage times. Canada's hydro and nuclear sources are not able to provide any further electricity for our domestic use. Over the past 7-1/2 years no new large-scale commercial source of energy has been developed. Research into potential high-energy generation technology by the DOE at the National Laboratories has all but stopped. Living without 24% of our electricity would be difficult if not impossible, expensive, and in my opinion, intolerable.

Current DOE policies inhibit further usage of nuclear, hydroelectric, and coal as fuel. Additional use of oil would be an economic nightmare and cause severe shortages in the necessary supply needed for transportation and strategic uses. Utilizing more natural gas for electric generation would cause severe natural gas shortages and a cost increase from 6.5 cents per kWh up to 19.7 cents per kWh. Thus causing the weighted average price per kWh of electricity to increase from 4.01 to 9.8 cents per kWh, an increase of 97% during the next four years. It is easy to display that the existing energy policies of Clinton/Gore under Secretary Richardson are strategically flawed.

A New Direction

With some common sense and practical policy implementations, the make up of domestic electric generation could be changed to the generation make-up shown graphically in Chart 4.

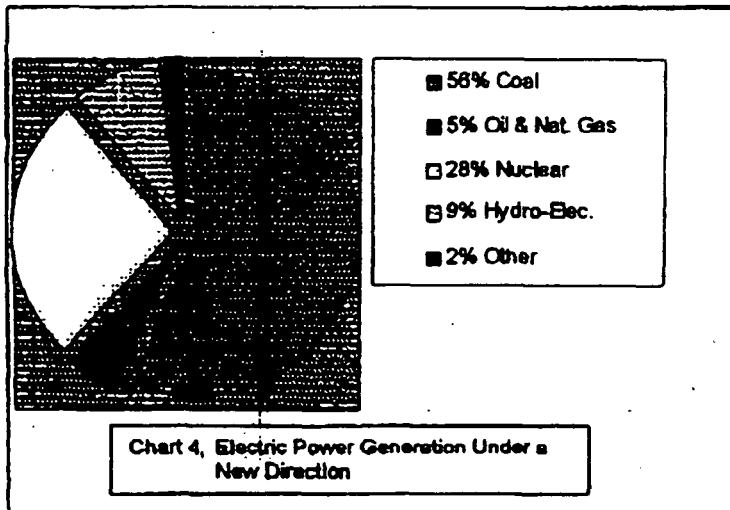

Resulting in a weighted average cost of 4.31 cents per kWh. The reduction from 11% to 5% of oil or natural gas used for power generation will save 405 million barrels of oil per year or 1,865 billion cubic feet of natural gas per year for other uses, thus eliminating fuel shortages in other industries.

The increase in nuclear power generation from 24% to 28% will come from start-ups of existing off-line nuclear power plants. The increase to 28% of the total

electric generation from nuclear is very conservative, because there is almost 38% nuclear generating capacity when all off-line power stations are considered. It should be noted that several of these nuclear generating stations are owned by the Federal Government, specifically the Tennessee Valley Authority (TVA).

Three changes must be made to DOE policy to keep current nuclear plants on-line and to get the off-line plants started up.

L

b6

1. The Yucca Mountain nuclear storage facility must be opened to accept commercial spent fuel. This opening of Yucca Mountain will uphold the DOE's commitment to nuclear utilities who have been taxed \$700 – \$900 million dollars for spent fuel storage. We know that this type of storage is safe and accepted by the DOE. Under the HEU agreement with Russia, the DOE has committed to take up to 400 metric tons of Russian nuclear weapons material. This 400 metric tons of HEU will produce as much as 320 metric tons of useless highly radioactive waste that is destined for permanent storage at WIPPS (Waste Isolation Pilot Plant) in New Mexico. WIPPS has already received and permanently accepted and stored 80 metric tons of this Russian waste. The WIPPS precedent proves ground storage of highly radioactive waste is safe and accepted practice.
2. Oak Ridge National Laboratory must be redirected to fulfill its original mission of nuclear fuel recycling. When ORNL was commissioned, its original mission target was to recycle up to 50% of nuclear spent fuel, thus, further reducing the amount of nuclear storage area by 50%. Since its commissioning ORNL has provided research into the enrichment, safe handling, transportation and purification of nuclear material. During Clinton/Gore most of these important tasks and projects have been terminated and ORNL is on a minimal budget simply to maintain its existence and some of its personnel. Important high-energy physics experiments must be restarted to provide the research necessary to be able to recycle up to 70% of nuclear spent fuel. These fiscally responsible research projects will predominantly be self-funded via the recycled nuclear fuel sold to utilities in addition to nuclear fuel processing and storage fees.
3. Many nuclear facilities 40 year operating licenses will expire in the early 2000s. If these plants are allowed to close almost 70% of the electricity generated by nuclear power plants will be unavailable. Electric supply shortages will result having grave consequences nationwide. Deliberate DOE research cancellations have caused a significant lack of data to support safe and reliable nuclear operating license extensions. By performing some modest research and reviewing and accepting private research already performed by the Electric Power Research Institute (EPRI) reasonable federal regulations can be put in place to responsibly address nuclear power license extensions to cover at least 5 more decades.

Other Necessary DOE Changes

Energy research needs to be accelerated in the areas of high-energy physics, fusion, hydrogen plasma research, and fuel cells. Energy research must include improving the efficiency of existing infrastructure technologies, e.g. higher efficiency turbines, superconductivity, and higher efficiency heat-exchanging technology. The DOE should identify technologies that have been developed by the National Laboratories that could be licensed or sold to US commercial industries. This revenue could help our National Laboratories budget money for more risky and long term technology such as commercial implementations of fusion and such portable applications as higher performance fuel cells.

L

Jbb

US energy policy must be modified to further utilize and develop US oil reserves, including the Alaska National Wildlife Refuge Area and offshore sites. In addition, reducing oil and natural gas as fuel for electric generation will: 1) extend these and existing oil reserves for many years beyond current projections; 2) lower the price per barrel of crude oil for transportation needs; 3) lower air/water emissions; 4) preserve fuel for transportation, home heating and strategic military operations; and 5) significantly reduce our national trade deficit.

L----- J b6

Assumptions and Models used in this paper:

- 1) Oil & Natural Gas are considered interchangeable fuels.
- 2) The amount of oil consumed for electric generation were calculated according to equations 1.1 – 1.5.
- 3) The amount of natural gas consumed for electric generation were calculated according to equations 2.1 – 2.5.
- 4) During the time period of 2000 – 2004 the average use of electricity in the United States remains constant. Note: that if US electric consumption increases the total electric use increases, however, only the shortage section grows, proportionally the generation percentages decrease. This is based on a fixed electric power generating capacity.
- 5) These models do not consider new electric power generating stations currently under construction. A composite list of current utility construction projects could not be confirmed.
- 6) The calculated average cost of electric generation is based solely on the weighted average of the generation by each fuel. Regional locations and peak load costs are not factored into these costs. Therefore, the calculated costs are different than costs observed by the electric consumer.

Calculations 1.1 – 1.5

1.1)	kWh generated by oil or natural gas	=	.11 X 3,785 billion kWh 416 billion kWh
1.2)	BTU / Barrel of crude	=	5,800,000
1.3)	1 kWh	=	3412 BTU
1.4)	1 Barrel of crude oil	=	5,800,000 / 3412 1,699 kWh X (efficiency) 33% 560.7 kWh
1.5)	Barrels per year	=	416.4 billion kWh / 560.7 kWh / Barrel 742.6 million barrels

Calculations 2.1 – 2.5

2.1)	1 cubic foot, natural gas	=	1050 BTU
2.2)	1 kWh	=	3412 BTU
2.3)	1 cubic foot	=	1050 / 3412 .307 kWh X .33 (efficiency) 33% .101 kWh
2.4)	1 kWh	=	9.90 cubic feet
2.5)	Cubic feet per year	=	9.90 X 416.4 billion kWh 4.122 billion cubic feet

L] b6

References:

- 1) United States Department of Energy timeline 1990 – 1998, website address:
www.energy.gov/aboutus/history/timeline99.html
- 2) United States Department of Energy "Tenure Highlights under Energy Secretary Bill Richardson", October 2000, website address:
www.energy.gov/aboutus/history/tenure.html
- 3) United States Enrichment Corporation, paper entitled: "Richardson on US-RUSSIA Uranium Agreement", December 1, 1999, website address:
www.usec.be/issues/usec1202.html
- 4) United States Enrichment Corporation chronology "Megatons to Megawatts." From January 1990 – October 2, 2000. website address:
www.usec.com/content/third/tier/newsreleases/08-31-98.html
- 5) United States Department Of Energy publication: (epmt02) Table 2, "US Electric Power Industry Summary Statistics.", October 2000. Web site address:
www.eia.doe.gov/cneaf/electricity/epm/html/epmt02p1.html
- 6) Philipp Bleek, Isaac Boxx, Lucas Cadena, Weihsueh Chiu, Andrew Evans, Joshua Sheras, Jeffrey Siegel, "Task Force Report on Preventing Nuclear Terrorism" WWS 453/708, May 1998, Princeton University web site address:
www.wws.princeton.edu/~wws453/report.html

bb

About The Author

James P. Langan



bb

personal phone:

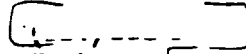

personal email:

jim.langan



James P. Langan is a seasoned electrical engineer with 19 years of experience and significant education and experience in nuclear engineering.

Mr. Langan has specialized in nuclear safety research, research published by Langan was nationally and internationally presented at conferences in 1988/89. In 1990 the US Nuclear Regulatory Commission (NRC) and the Department of Energy (DOE) indoctrinated a nuclear safety testing practice into law that was developed and proven from Langan's research. This research resulted from a US NRC Small Business Innovation (SBIR) contract awarded to Langan's company.

Since its acceptance, this testing practice has saved US nuclear utilities millions of dollars in testing costs and increased the safety margins of operating US nuclear power plants. In 1988/89 Langan was the recipient of a special award entitled "Wisconsin Innovation and Research Award" presented by Wisconsin, Governor Tommy Thompson.

Fax Memo to Vice President Cheney

Date Jan 30, 2001
To The Honorable Dick Cheney, Vice President Fax 202 456 6212
From Dale W. Steffes, Tel
Subject Formation of United States Energy Policy

BB
Dale Steffes

Page 1 of 4

Congratulations to President Bush and you on your election.

Also congratulations on your designation to lead a committee to address the need for an United States Energy Policy.

I have worked on this problem for more years than I care to admit. But I would like to share some input that might be a help to your new committee. Secretary of Energy O'Leary attempted a similar effort early in her administration. I followed that effort very closely and tried to help it by publishing the Oil Security Newsletter.

Included is some documentation for background information. See 7 22 94 letter that was sent to the attached list requesting their input on national oil supply security.

The whole effort started with the Domestic Natural Gas and Oil Initiative of Dec. 1993. It was a noble effort on her part, but she couldn't get her fellow departments to go along. See newsletter No. 9, Dec. 15, 1995 which more or less summarizes this effort.

I previously sent you a copy of the energy proposal I submitted to the Clinton Administration the day he took office (Jan 21, 93). Your copy should have arrived the day you took office (Jan 20, 01)

My advice to your committee is that they will not be able to make energy policy with today's energy models and data. Current energy models in use today do not factor in cost adequately. The general public still does not understand the energy industry, especially the costs

Finally, I ask you not to distort the energy price signals. They are the most valuable data we have

I would be honored to share my 15 year experience working for a National Energy Stability Policy with you and your committee. Let me know how I can be of assistance.

PS. I worked with the Commerce Secretary's dad 30 years ago hosting in Houston one the first national seminars on energy. It was for the country's National Association of Business Economists. About 200 business economists attended. We would have had another 50 attend but they elected to go to Washington to hear the next phase in President Nixon's wage and price controls. The third person who served on our committee was the chief economist for Exxon USA

CC: Tammy Blair

29542

ROBERT T. MARTIN

The Honorable Spencer Abraham
United States Department of Energy
1000 Independence Ave
Washington DC 20585

January 30, 2001

Dear Mr. Secretary:

Enclosed is my resume. Because of my experience in the electrical utility industry and extensive knowledge of the energy business I would like to offer my services in helping to develop a National Energy Policy. I write not asking for a job and certainly have no interest in relocating to Washington DC but do think that I could be helpful working on a committee or a task force.

I am thoroughly familiar with the fuels available for the generation of electricity and the environmental impact, actual and perceived of each. Also, I am aware of the political, consumer, and public relations aspects of each.

I have supported every Republican nominee since I was old enough to vote. My wife and I gave the maximum allowable to George W. Bush. I have been a member of the Presidential Roundtable and attended the 1996 Convention in San Diego. I was a member of the task force that traveled to Scranton to campaign for George W. and Congressman Don Sherwood.

I am eager to serve if you so desire.

Sincerely,

Robert T. Martin

ROBERT T. MARTIN

BB

EDUCATION:

UNIVERSITY OF TEXAS AT AUSTIN

Bachelor of Science, Mechanical Engineering-1948

EMPLOYMENT:

- 1991-present ROMAR OIL, INC. (small family oil company), President.
Engaged in community and public service activities
- 1989-1991 Retired (engaged in community and public service activities)
- 1984-1988 HILL AND KNOWLTON (international public relations firm), Senior Consultant
- 1965-1983 TEXAS ELECTRIC SERVICE COMPANY, Fort Worth, Texas, Vice President. Held various corporate jobs. Elected Vice President in 1971 with responsibilities for public relations, public affairs, employee and customer communications, consumer affairs and personnel relations. Involved in corporate planning to diversify fuel supplies for power plants. Responsible for initial contact and continuing successful efforts to gain public acceptance of Commanche Peak Nuclear Power plant. Member of Texas Utilities Public Relations committee. For a time was Chairman of Edison Electric Institute's Consumer Affairs Committee.
- 1961-1964 MOLONEY ELECTRIC COMPANY. Regional Sales Manager for power equipment
- 1948-1960 WESTINGHOUSE ELECTRIC CORPORATION, Graduate Student Training program, Generation, transmission, and distribution sales responsibilities in Los Angeles and Dallas.

MILITARY SERVICE

- 1943-1946 United States Navy, Navy V-12 program resulting in Commission. Served as Engineering Officer on the USS Casa Grande. Honorably discharged after 3 years service.

PUBLIC AND COMMUNITY SERVICE

Fort Worth Community Development Council- served 6 years
Texas Real Estate Commission- served 6 years
DFW Airport Board- served 4 years
Member and Past Chairman-Fort Worth Streams and Valleys Committee
Life Member of the Fort Worth Chamber of Commerce
Past Chairman of the Fort Worth Museum of Science and History
Past Chairman of the Longhorn Council of the Boy Scouts of America
Board Member of the Moncrief Radiation Center
Board Member of Junior Achievement of Tarrant County

PROFESSIONAL AFFILIATIONS

Registered professional engineer
Life member of the Texas and National Societies of Professional Engineers
Senior member of the Institute of Electrical and Electronic Engineers

PERSONAL

Married to Marilyn McDavid since 1949, two children
Deacon at McKinney Memorial Church- Founded and chaired Local Mission Board

2001-003192 2/5 A 9:57

Secretary, The

b6

003192

From:
Sent: Tuesday, January 30, 2001 2:52 PM
To: Secretary, The
Subject: Consumer Information Comment Form

FROM: _____ b6
NAME: Robert F. Tulloch
SUBJECT: Nuclear Generation
ZIP: _____ J b6
CITY: Munith
PARM.1: TO:the.secretary@hq.doe.gov
SUBJECT:Consumer_Information_Comment_Form
STATE: MI
TOPIC: Nuclear Energy
SUBMIT: Send Comments
CONTACT: email
COUNTRY: USA
MESSAGE: Spencer Abraham, Secretary of Energy: I moved to Ann Arbor, Michigan from Berkeley, California in 1972 to do engineering on the Midland Nuclear Plant. I have always had a great interest in nuclear energy and been a great supporter. The current state of energy policy in our country is appalling and has been for many, many years. We had and still have an opportunity to lead the world in nuclear energy as long as we have an administration that is supportive. I watched a nightline show sever
MAILADDR [J b6

Secretary, The

2/5 950

003086

From: daniel.gallagher@SAP.COM%internet [daniel.gallagher@SAP.COM]
Sent: Wednesday, January 31, 2001 8:26 AM
To: Secretary, The
Subject: Consumer Information Comment Form

FROM: daniel.gallagher@sap.com
NAME: Daniel Gallagher
SUBJECT: Energy Policy
ZIP: € B6
CITY: I
PARM.1: TO:the.secretary@hq.doe.gov
SUBJECT:Consumer_Information_Comment_Form
STATE:
TOPIC: Renewable Energy
SUBMIT: Send Comments
CONTACT: email
COUNTRY: € B6
MESSAGE: January 31, 2001 Dear Mr. Secretary,

I am honored to write a letter to you regarding our national energy policy and hope you have time to read it. I'll try to keep it short.

I read in the news today that we proposing to encourage more domestic oil exploration and less dependence upon foreign oil. One reason this issue has been discussed is the energy crisis in California. I think the goal our your proposal is good (energy independence), but I respectfully disagree with your proposal to widen o
MAILADDR B6

b6

Fax Memo to Vice President Cheney

Date Jan 30, 2001
To The Honorable Dick Cheney, Vice President Fax 202 456 6212
From Dale W. Steffes, [] b6
Subject Formation of United States Energy Policy

Dale Steffes

Page 1 of 4

Congratulations to President Bush and you on your election.

Also congratulations on your designation to lead a committee to address the need for an United States Energy Policy.

I have worked on this problem for more years than I care to admit. But I would like to share some input that might be a help to your new committee. Secretary of Energy O'Leary attempted a similar effort early in her administration. I followed that effort very closely and tried to help it by publishing the Oil Security Newsletter.

Included is some documentation for background information. See 7 22 94 letter that was sent to the attached list requesting their input on national oil supply security.

The whole effort started with the Domestic Natural Gas and Oil Initiative of Dec. 1993. It was a noble effort on her part, but she couldn't get her fellow departments to go along. See newsletter No. 9, Dec. 15, 1995 which more or less summarizes this effort.

I previously sent you a copy of the energy proposal I submitted to the Clinton Administration the day he took office (Jan 21, 93). Your copy should have arrived the day you took office (Jan 20.01)

My advice to your committee is that they will not be able to make energy policy with today's energy models and data. Current energy models in use today do not factor in cost adequately. The general public still does not understand the energy industry, especially the costs

Finally, I ask you not to distort the energy price signals. They are the most valuable data we have

I would be honored to share my 15 year experience working for a National Energy Stability Policy with you and your committee. Let me know how I can be of assistance.

PS. I worked with the Commerce Secretary's dad 30 years ago hosting in Houston one of the first national seminars on energy. It was for the country's National Association of Business Economists. About 200 business economists attended. We would have had another 50 attend but they elected to go to Washington to hear the next phase in President Nixon's wage and price controls. The third person who served on our committee was the chief economist for Exxon USA

CC: Tammy Blair

29547

DOE

bb

From: [redacted]

on 01/30/2001 09:22 PM GMT

To: "George W. Bush" <president@Whitehouse.GOV>
cc:
Subject: Please do not destroy the planet

Mr. Bush--

I write urging you to look beyond your roots as an oil company executive, and take a different approach to energy policy.

The US consumes a share of the global resources far in excess of its tiny fraction of the global population. I'd call this pretty unfair as well as a pretty big problem. Your predecessor at the White House was an anti-environmental fanatic. Yes, he got some favorable press for preserving a few tracts of land here and there, but most people just ignore his disastrous forest policies, his torpedoing of the Kyoto Treaty, and his careful maintenance of the US average fuel economy at the 1990 level. Really, not much different from your father.

I figure you want to make Clinton look bad by comparison to you, and I think a great way would be to boot Mr. Cheney (another oilman - don't you guys talk to anyone else?) from the task force on energy policy, protect all US lands in perpetuity from the catastrophes wrought by oil drilling, and save us all from foreign domination by imposing rationing and forcing everyone to consume LESS instead of MORE. That last part alone would instantly earn you a unique and beloved place in US and world history. If we didn't waste so much, there would be no "energy crisis". Oil is a pointless pollution increase. Why not go after the root problem?

I always thought conservatism ought to have something to do with conservationism. Why not abandon the tired old, earth destroying solutions of the past and make a new name for yourself and your party? That way you can thumb your nose at Mr. Clinton and his ilk and leave a planet to your children as well. What do you say?

--Jamie Pehling

[redacted]

] bb

100

From: [] on 01/30/2001 09:45 PM GMT

b6

To: president@Whitehouse.GOV
cc:
Subject: Energy Policy

I am astounded and disappointed to hear your first words on an energy policy to be: Find More Oil, generate more electricity. No word on conservation policy or on the pollution problems inherent to burning more fossil fuel.

The last sensible policy I heard on energy was Bill Clinton's BTU tax. Raising the price of any commodity will encourage conservation.

A F DELALOYE

[] bb

DOE

bb

From: [redacted] on 01/30/2001 11:12 PM GMT

To: president@Whitehouse.GOV
cc:
Subject: energy and the environment

From:
Louis Liebhaber

[redacted]

] bb

President Bush:

Dear President Bush,

You have assembled a group of advisors who are smart and highly experienced. Surely given the enormous talent of that team you can find more responsible ways to assure that this nation has the energy resources it needs than to seek out oil and gas in the sacred wilderness of our country.

As an elected official and a leader of the greatest nation on the face of the earth you have an obligation to promote the long term view not cave in to the avarice of the those who would create a sense of hysteria over the current electricity shortage in California. How could you even consider invading the sanctity of areas which support tranquility, endangered wildlife and a refuge of all men now and in future generations ? What about a responsible position promoting conservation of energy and the responsible development of alternative energy sources? Surely with all of the money and talent we have in the country we can see beyond todays craving and sacrifice a bit to assure that we BOTH have our energy needs met for the future AND we have wilderness areas for our future posterity.

What do you want your legacy to be ? The Exxon Valdez ? The Galapagos spill ? or new sources of responsible energy and places for your gandchildren to explore the wonders of nature ?

Do the right thing ! Not the expedient thing - that's the mark of a true leader.

Sincerely,

Louis Liebhaber

Sincerely,

DOE

From:

on 01/30/2001 03:07 PM GMT

b6

To: president@Whitehouse.GOV
cc:
Subject: Energy Policy

Dear Mr. President

I strongly support a change from the status quo of our energy policy (or lack thereof) and I have a few suggestions that seem glaringly obvious but that have been largely ignored.

First I want to point out that our current energy distribution system is negligently one-sided. We rely almost solely on fossil fuels to meet our energy needs. As we are finding in California and elsewhere, this is disastrously shortsighted. The primary goal of any new energy policy must be to remove our dependence on fossil fuels. Much as been made of the your desire to decrease our dependence on foreign oil by developing domestic sources. This is grossly insufficient and completely ignores the problem of our dependence on oil itself.

Estimates of remaining fossil fuel supplies abound and can be used to support any point of view, depending on which estimate one chooses. There are, however, a few facts that do not rely on estimates. First, all fossil fuel sources are limited. Only the self-deluded pretend that fossil fuels can continue to meet our energy needs indefinitely. Next, the development of fossil fuel resources causes extensive environmental damage. Companies claim that they can obtain oil in an environmentally friendly way. This is simply not true. I've worked around many oil fields and have yet to see a single one that didn't resemble a war zone. Then, of course, are the devastating methods we use to obtain coal. Unlike their petroleum counterparts, coal companies at least have the decency not to attempt to dupe us into believing that their methods are environmentally benign. Finally, the use of fossil fuels causes problems for humans and the environment everywhere on the planet. Global warming is already causing vast financial losses from increasingly erratic and violent weather systems. Even the seemingly localized air pollution of our metropolitan centers is dispersing across relatively pristine regional areas causing stresses to multiple environmental systems. This is not merely a problem of aesthetics; human-induced stresses on environmental systems always cause unanticipated problems. History shows quite clearly that harming the environment ultimately harms us.

So any energy policy that perpetuates our reliance on fossil fuels is self-defeating and not worth pursuing. On the other hand, we are clearly reliant in the near term on these fossil fuels. What, then, are we to do? Perhaps the most important thing to keep in mind while pondering this question is that, in the long term, we do not have to rely on fossil fuels to meet any of our energy needs! With a little intelligent planning, existing fossil fuel sources can be sufficient to supply all of our near

29551

term energy needs while we transition to a sustainable energy solution. The only sustainable solution available to us is the same one that has been obvious for decades: renewable energy sources such as solar, wind, geothermal, and tidal. Ultimately, it is clear that we will have to rely on a multifaceted energy distribution system that is primarily dependent on a variety of renewable energy sources. Anything less exacerbates our energy problems.

I believe, however, that merely changing our energy dependency from fossil fuels to renewable energy sources is not the complete answer. Along with this switch must come increases in energy efficiencies. This has the added benefit of helping decrease our reliance on foreign sources of petroleum without developing new domestic sources. Any complete energy policy must include incentives and/or regulatory requirements for substantial increases in energy efficiencies in our appliances and vehicles.

In the final analysis, the only good energy policy is one that increases energy efficiencies and lays a short path towards a multifaceted, renewable-based energy distribution system. Please write to me and explain how you will work towards the above stated goals. A solid, renewable-based energy system will allow our country to continue to lead the world economically, environmentally, and energetically.

Sincerely,

Kurt D. Anderson

[] bb

PS. As I completed this letter, I found that the your own brother has sent a letter to the Interior Department in an attempt to prevent any consideration of developing off-shore petroleum sources near Florida. In this letter, Governor Bush stated, "I am confident that the new administration will recognize the need to protect sensitive natural resources located both offshore and along Florida's coastline for the benefit of the entire nation." I sincerely hope your administration will take this keen understanding to heart and prevent the abuse of natural areas merely to perpetuate an antiquated and problematic fossil fuel-based energy system!

Die

Db

From:

> on 01/30/2001 06:09 AM GMT

To: "President George W. Bush" <president@Whitehouse.GOV>
cc: Vice-President Richard Cheney <vice.president@Whitehouse.GOV>
Subject: Shared Energy Corporation

Dear President Bush,

Congratulations on your being elected and sworn in as the nation's 43rd Chief Executive Officer and Commander-in-Chief. I want to personally let you and Mrs. Bush, Vice-President Cheney and Mrs. Cheney, your respective staffs and cabinet members know that I am being obedient to the Word of God and I am indeed in prayer for you, our leaders.

President Bush, I will continue to pray for your health and well-being, that you'll be encouraged, that you'll make the right decisions concerning the country and our neighbors abroad, and that God's favor and protection will surround you like a barrier around a fortress. I also want to express my love and concern for you and all of the aforementioned personnel. Please do a good job for this country, as I know you will, and I believe bigger, better and brighter things will happen for you and this country.

President Bush, I also want to let you know that I am a man of God, with Godly principles and full of the faith that it takes to please God. I'll be in your corner and your supporter. If ever I can provide a word of counsel, comfort or inspiration then I am willing to perform that duty. I wanted to share that information with you so that you would know that there are people that truly care and are really excited about the future that is before us!

President Bush, I also wanted to introduce you to a company that I recently formed named Shared Energy Corporation. I read today on the AP News Wire where you have issued directives on the formation of a Federal Energy Policy. My company was formed to focus on such issues. Our mission will be to reduce energy consumption by utilizing energy management technologies in order to achieve greater levels of energy efficiencies and reduced costs, thereby reducing the production of greenhouse gases and acid rain which greatly affect our environment. Alternative energy sources are also a part of our business plan that we will endeavor to research and develop.

President Bush, I desire that Shared Energy Corporation would play a part or be a working team member in dealing with the aspects of this new energy policy.

Following is the company's contact information:

Shared Energy Corporation
P.O. Box 4726
Marietta, GA 30061-4726
ATTN: John T. Flack III, President

(770) 424-8560 {VOICE}

(770) 424-1355 {FAX}

{John's Cellular}

{John's Home}

bb

I thank you for your time and indulgence in this matter. Together, I believe these problems can be solved and they will be solved. There is nothing that is impossible for us to do when we work together for the solutions.

Thank you again and I wish you God's speed. God bless you.

John T. Flack III

Doc

From: (b)(6) on 01/31/2001 05:45 AM GMT

To: "George W. Bush" <president@Whitehouse.GOV>
cc:
Subject: A Real Energy Policy

Dan R. Lafoon

bb

Mr. Bush,

First I would like to congratulate your and Mr.Cheney's ascension to office.I have never done this before,but I think this topic merits attention,especially since you announced that you were about to embark on this task.As you have obliquely mentioned in the past,the USA is in trouble energy supply wise,as the world itself may be one day as far as fossil fuels are concerned.As you also said,the government should not necessarily try to run everything, but we also know that when the government and the people wish,much can be done more quickly.To the point,we need to develop more green power in the form of wind power, the more constant type of natural renewable resource,compared to solar,and especially in more windy states like Texas(charted to be #2),but in full utility scale wind projects with current improved technology to help ensure our future standard of living.There are two newer projects in West Texas currently running,and more online in other states,but we need much more of this clean power developed,along with the job base it brings,and the internal cash flow to our economies,as well as the energy,and the bottom line is,no,it's still not perfect when the wind is not blowing,but it works and I believe we need more tax credits and other legislative encouragement to get more of these large projects built,the scenario of a wind turbine in everyone's backyard will not be efficient enough to do it.And they can be built quickly,it surely cannot be any worse than the current power scenario in California.I am simply asking that this area be very well scrutinized for I believe it can become a lasting lynchpin of our national energy policy,but look at the newer projects like near Big Springs and Mcamey to truly get an idea of the potential efficiency,the older wind farms are not as so.I also agree with incrementally opening up other previously off limits areas to drilling,and I applaud your grasp and attention of the energy situation we are in,we cannot ignore

these facts.

In closing, I wish the best for your administration, you will all be in our prayers as you lead this nation, and we like the faith charity help plan, fresh ideas are what this country needs.

May God Bless

Sincerely,

Dán &

Karen Lafoon

pe
From:

bn 01/31/2001 02:59 AM GMT

To: President <president@Whitehouse.GOV>, Vice President <vice.president@Whitehouse.GOV>

cc:

Subject: Your Irresponsible Energy Policy

Mr. President and Mr. Vice President,

Your energy policy that was put forth yesterday is an offense to any long term thinking American. Using the California crisis to push an unsound policy that has little or nothing to do with California power concerns is deceitful at best and a tragedy at worst. Continued reliance on non renewable resources such as gas and oil at the expense of the environment will only exacerbate an already dangerous problem. Your intentions to drill in the Arctic National Wildlife Refuge and granting waivers to states that run older power plants, even if they VIOLATE clean air standards crosses the line to criminal activity and reveals a flagrant disregard for future safety of this country's air, water, and land. Producing policies whose main beneficiaries are oil companies, who would obviously love to see weakened environmental controls in exchange for more profit, shows an administration who would put the wealthy before even the SAFETY of the American people, not to mention our neighbors who must deal with the fallout of our environment policies. The answer doesn't lie with oil but in alternative renewable power sources. The United States should, and eventually must, put its energy and money into research to get us out of the crippling fiasco of an economy is too bound up with a resource that will eventually run out. If its not futile enough to tie our future to a dead end, then at least refrain from destroying the environment in which we all have to live in the process. Try looking for solutions that have long term benefits that future generations can appreciate and enjoy rather than running over the same tired ground that we know one day will fail. If we don't invest in alternatives now, before more energy crises show up in the headlines, you will doom us to a country whose land air, and water were ravaged in a quest for greed and short term solutions. I hope that you both would like a more noble legacy than that for your administration.

Sincerely,

Tom Benham

 - att1.htm

bb
bb
29557

From: David and Angie -

(b)(6)

on 01/30/2001 02:20 AM GMT

To: president@Whitehouse.GOV

cc:

Subject: Energy Policy

Dear Mr. President:

My family and I are strongly opposed to any reductions in the requirements or enforcement of the Clean Air Act. Our current energy problems are not best solved by allowing more pollution to our life giving air. Further, we are also profoundly against any proposals to open up ANWR for drilling, mining or any other form of extraction. Our future generations should never be robbed of this pristine national treasure for the short term gain of today. We urge you to look at sustainable solutions to our energy problems and to keep our invaluable public health and rare unaltered environments protected for us and our children.

Sincerely,
Angela Jones

(b)(6)

 - att1.htm

29558

b6

I. Arthur Hoekstra, PE

[] b6

Energy secretary, Spencer Abraham
1000 Independence Ave. SW
Washington, DC 20585-0001

January 30, 2001

Dear Mr. Abraham,

Re: Energy Policy

The Wall Street Journal of January 29, 2001 has an excellent article about you and your task of creating an energy policy. It also says you are going to encourage the construction of new clean-burning coal-fired power plants. I have several patents on this subject which have now expired but I believe the concept is useful.

I will enclose a letter I sent to VP Dick Cheney on energy policy.

Let me repeat that garbage is an inexhaustible and replaceable energy supply. Typically the generator of the waste pays the cost of incineration. Any power obtained reduces the cost and likewise, any heat recovered reduces the cost.

And if the generator pays the cost of disposal, the resulting energy is FREE. Can you match that?

My method of cleaning the flue gas is exactly the same as occurs in nature where the contaminants are removed by a water wash in the form of condensation and rain. In my process the process occurs much faster and the contaminants are confined and collected for proper disposal rather than allowing them to be dispersed over the landscape. This is why my system is better than any other for both recovering the heat and controlling pollution.

I had contacted Geo. Lewett of the energy department in 1989 so you may have a file on my proposed system which you can review. I hope this will help you in your new task.

Yours truly,

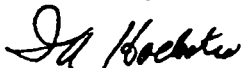

I. Arthur Hoekstra
Cc VP Dick Cheney

063184

Secretary, The

From: Tom Anderson [b6]
Sent: Tuesday, January 30, 2001 10:07 AM
To: Secretary, The
Cc: Tom Sevier
Subject: National Energy Policy



tmp.htm

Good morning Secretary Abraham, from Corpus Christi, Texas:

My name is Tom Anderson, and my resume was forwarded to you by Senator Kay Bailey Hutchison. The Transition Office also has my resume and application.

I am writing because I have a definite interest in working with you in the establishment of a National Energy Policy. My view is that the policy will have three facets: A near term policy to address our acute problems in the price and availability of oil, natural gas, and electricity. A midrange policy, centered on fossil fuels and lessening our dependence on foreign sourcing. And a long range policy, acknowledging our fossil fuel infrastructure, but evolving the nation into utilization of alternative and renewable energy.

As anticipated, the President has established a task force, under Vice President Cheney, to deal with the issue. That task force consists of cabinet level individuals, of which you are one. But you will need considerable assistance in doing the research, formulating the ideas, and getting the work done.

I am an electrical engineer, in private practice, serving the process industries. I also do work in photovoltaics, co-generation, and have ties to an Australian developed process that provides extremely clean burning coal. I am writing to you in hopes I can provide some assistance in what will be one of the most important aspects of the Bush Administration. Please let me hear from you.

Yours truly,

Thomas A. Anderson, P.E.

Office: 361.653.1234
E-mail:

For Reference at the Transition Office: SSN [

] b6
] b6

2001-003192 2/5 A 9:57

003192

Secretary, The

From: 1 internet j
Sent: Tuesday, January 30, 2001 2:52 PM
To: Secretary, The
Subject: Consumer Information Comment Form

B6

FROM: tr
NAME: Robert F. Tulloch
SUBJECT: Nuclear Generation
ZIP:
CITY:
PARM.1: TO:the.secretary@hq.doe.gov
SUBJECT:Consumer_Information_Comment_Form
STATE:
TOPIC: Nuclear Energy
SUBMIT: Send Comments
CONTACT: email
COUNTRY: USA

B6

B6

MESSAGE: Spencer Abraham, Secretary of Energy: I moved to Ann Arbor, Michigan from Berkeley, California in 1972 to do engineering on the Midland Nuclear Plant. I have always had a great interest in nuclear energy and been a great supporter. The current state of energy policy in our country is appalling and has been for many, many years. We had and still have an opportunity to lead the world in nuclear energy as long as we have an administration that is supportive. I watched a nightline show sever
MAILADDR: 7

B6

DoE
From: John Doelman [

bb
] 01/31/2001 04:19 PM GMT

To: president@Whitehouse.GOV
cc:
Subject: Responsible Energy Policy

Dear Mr. President,

As a Floridian who votes, I have a few questions. I understand the politics going on today but for the life of me I can't understand why we are in this energy crisis. For those Americans who don't see it, they are just blind. It is possible that within the next few years, or months even, that we could experience shortages like we have never seen before.

Why are you and our government, Democrats and especially Republicans, pushing for any tax cut at all when we now have the opportunity to devote these financial resources to creating a responsible energy policy that could ultimately save the entire planet from the stranglehold of non-renewable, dirty energy? Doesn't our govt. have the duty to serve the public in a manner that is consistent with the premise of equality and the promise of doing all that is necessary to insure continued quality of life for every American?

It seems to me, if we were to devote a significant portion of the surplus to expanding the R & D of renewable, clean, and safe energy, the middle and long term benefit would be immense, much greater than the short term benefit of reduced taxes to a few. We would not only remove our incredible dependence on a volatile part of the world but would also create something that could be exported. It would not only save money, but would make money too!

As the stated leaders of the world, we do have a duty to act responsibly in our actions. If everyone sees us as greedy users, and I think we are, than we are not fulfilling our highest and best purpose. With the amount of physical power we now enjoy, we could be the country that eliminates the "bully" from most of history's powerful countries labels. Let's change our reputation and really think about how we are projecting ourselves to the rest of the world. Greedy really stinks as a reputation.

Doesn't our government care about the future generations who will inherit what we leave behind? If all we do is consume with little mind for giving back, our legacy will be not unlike that of the former Soviets. Eventually the damage will be so great that even enormous amounts of money will not be able to correct it. This is our opportunity to really make a difference, here and abroad, and it makes me sick seeing what we are doing.

We are the only country in the world who has this chance, though it will benefit everyone in every country. Oil is not the longterm answer, it can't be. It is a finite resource. With the dollars at our disposal now, we can find a longterm answer, without any more Exxon Valdez disasters.

A concerned citizen,

29562

John Doelman

EMail

 - att1.htm

}66

Secretary, The

2/5 950

003086

From: daniel.gallagher@internet [daniel.gallagher]
Sent: Wednesday, January 31, 2001 8:26 AM
To: Secretary, The
Subject: Consumer Information Comment Form

]B6

FROM: daniel.gallagher@sap.com
NAME: Daniel Gallagher
SUBJECT: Energy Policy
ZIP: []
CITY: [] B6
PARM.1: TO:the.secretary@hq.doe.gov
SUBJECT:Consumer_Information_Comment_Form
STATE:
TOPIC: Renewable Energy
SUBMIT: Send Comments
CONTACT: email
COUNTRY: []
MESSAGE: January 31, 2001 Dear Mr. Secretary,

I am honored to write a letter to you regarding our national energy policy and hope you have time to read it. I'll try to keep it short.

I read in the news today that we proposing to encourage more domestic oil exploration and less dependence upon foreign oil. One reason this issue has been discussed is the energy crisis in California. I think the goal our your proposal is good (energy independence), but I respectfully disagree with your proposal to widen o

MAILADDR: []

]B6

b6

Dennis B. Swartout

} B6

February 1, 2001

Mr. Spencer Abraham
U.S. Department of Energy
1000 Independence Ave., SW
Washington, DC 20585

RE: Swartout National Energy
Policy & Petrol-Fee

Dear Mr. Abraham,

I would like to congratulate you on your appointment and confirmation as new United States Secretary of Energy.

I am enclosing a copy of the National Energy Policy that my father and I have developed and worked on for the past 25 years. We would be glad to help you implement it if you have any questions or want our assistance.

Thank you and Best Wishes,

SINCERELY,

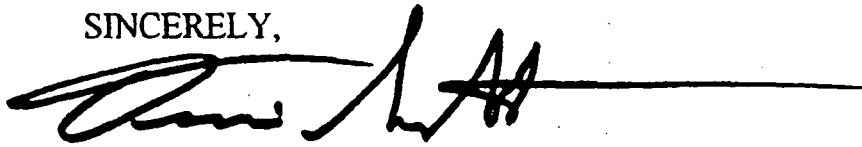

Dennis B. Swartout

SWARTOUT ENERGY POLICY (SWEP) FOR AMERICA

Petroleum Fuel Consumption Fee (PETROL-FEE) October 31, 2000

America's National Energy Policy should include a \$1.00 per gallon fee on consumption of petroleum fuel. To minimize economic disruption and provide an orderly transition to the new "post-petrol" economy, the fee should be phased in \$.10 cents per year for 10 years beginning a year after enactment. No fee would be imposed on petroleum-based products, materials or other energy forms.

Petrol-fee is not a tax. Revenues will be used for, and paid back into, the source of the revenue. Thus, giving value received for payment made. For example, revenue collected at the gas pump can be used to fund transportation infrastructure. Building bridges, roads and highways. Fees collected on heating oil can be used for making homes more energy efficient and for converting furnaces to gas or alternate fuels. Revenue collected from electric utilities could be used for technology and research developing alternate energy sources. Electric utility companies would soon convert to gas, fuel cells, flywheel energy storage, solar, wind, geo-thermal or coal to avoid paying the fee.

ADVANTAGES:

1. CONSERVATION WITHOUT GOVERNMENT CONTROL: Supply and demand. The more oil costs, the less demand, the more conserved.
2. ENCOURAGE ALTERNATE ENERGY USE AND R&D: Higher cost petroleum makes alternate energy more competitive and profitable. That makes more R&D possible and financing available. Fuel cells, energy storage, recuperators, waste heat boilers, solar, wind and geo-thermal. All need more R&D. Cheap oil prices have discouraged and retarded alternate energy development.
3. ENERGY INDEPENDENCE - REDUCE FOREIGN OIL IMPORTS: The Swartout policy (SWEP) would soon make our country independent of foreign oil imports. The price of foreign oil should start dropping the day congress enacts SWEP.
4. REDUCE TRADE DEFICIT: Petroleum import reduction will contribute to a stronger trade balance of payments ratio with our world trading partners.
5. REDUCE AIR POLLUTION, THE GREENHOUSE EFFECT AND OZONE DEPLETION: Largely caused by burning petroleum fuel.
6. PROLONG SUPPLY OF EXHAUSTIBLE RESOURCE: Someday petroleum reserves will be depleted. We should start looking for alternate energy sources now. SWEP will provide motivation to locate and develop new gas fields, deep geo-thermal wells and to perfect clean coal technology.
7. REBUILD THE NATION'S HIGHWAYS: Many of our country's roads and bridges are in shambles. State and local government can use this revenue to replace aging infrastructure.
8. CREATE JOBS: Replacing obsolete highways and bridges will create tens of thousands of jobs. So will the alternate energy R&D. A tremendous stimulant to our economy and tax base.
9. MINIMUM BUREAUCRACY & GOVERNMENT CONTROL: The Swartout Energy Policy (SWEP) works on the principle of free market supply & demand economy. Since there are already State and Federal gas taxes, there is already a fee collection method in place without hiring additional government employees. In fact, with SWEP, the Federal Department of Energy could be eliminated.

25
DOE

Philip Carlson, MD

(b)(6)

February 1, 2001

Dear Mr. President,

I am writing to express my concerns about what I think is the most pressing economic issue facing this country, and that is the affordability and stability of our energy supply. The only practical long-term solution to our base load electrical energy needs is the revitalization and advancement of nuclear technology for the generation of electricity. The advantages of nuclear generated electricity and nuclear power in general include the following.

1. Inexpensive and abundant uranium, thorium and plutonium fuel supply domestically available
2. No pollution released into the atmosphere
3. Proven safe technology
4. The only non-fossil fuel alternative capable of supplying the large amount of base load electricity necessary for future energy needs
5. Waste is extremely minimal if we utilize a closed fuel cycle and fast neutron breeder technology (as in France and other countries)
6. Nuclear power is the only practical way to produce the amount of hydrogen that will be needed in addition to electricity to replace fossil fuel for transportation and industry
7. New technology reactors and separation techniques are more weapons proliferation resistant.

I propose that the government take the following steps as part of a new energy policy that recognizes the central role of nuclear generated electricity and nuclear generated hydrogen.

1. Restart the breeder reactor research program (which was cancelled by President Clinton in 1993) with the goal of creating a standardized reactor design that can be placed safely and cost effectively in commercial operation with a closed fuel cycle (i.e. the French Phenix).

2. Change to a "closed fuel cycle" policy in the United States whereby spent nuclear fuel presently in temporary storage is purified and recycled to be used as fuel again (MOX). This will minimize waste and maximize fuel efficiency (already done in many other countries)
3. Open the Yucca Mountain waste repository
4. Promote the design and construction of Generation 3 and Generation 4 advanced technology nuclear power plant facilities in the United States to meet our present and future electricity needs
5. Work with other countries with advanced nuclear programs to develop a standardized proliferation resistant reactor to help provide electrical power to the third world. This would be a major step forward in solving the problems of hunger, poverty, disease, overpopulation and air pollution.
6. Massively fund research into the design and development of efficient battery driven and hydrogen fueled vehicles and fuel cells (an Apollo Space Program type of effort) so that we will eventually phase out our need for oil (and be rid of its pollution as well)
7. Provide incentives for producing and purchasing fuel efficient and gas/electric hybrid vehicles and conversely disincentives for manufacturing and purchasing fuel inefficient vehicles
8. Incentivize renewable energy resources such as wind, solar and geothermal which may contribute "peaking" electricity generating potential

Presently nuclear energy may not seem to be politically popular but that will change as people become aware of the many negative environmental and economic impacts that ultimately go along with energy produced from fossil fuel. Please consider the above suggestions as you formulate a national energy strategy affecting not only us but also many generations of Americans to come.

Sincerely,

Philip K. Carlson

2001-003613

b6

Spencer Abraham
Secretary of Energy
White House
Washington, DC

1 February, 2001

Dear Secretary:

Congratulations on your new job, which is going to be a difficult one. I read President's energy policy and I found it to be weak and toothless. Let me make some points and suggestions.

Nuclear Power. It hasn't been discussed or addressed for a decade and yet new plants are needed badly. Mr. Secretary, there is a world out there outside of Michigan and USA, including countries where over half of energy is provided with nuclear power, sans accidents, sans high construction costs sans pollution, sans high fuel costs, etc. Did you know that the most energy-efficient nuclear plants are in Switzerland and Finland? It probably is a surprise to you. These are small countries, which cannot afford the multi-billion dollar initial costs we are used to. Neither have they reinvented the wheel with each plant, as we are wont to do. Nuclear power in the right hands is the least polluting option of all, giving off only water vapor into the air and warm water into a canal or stream. Instead of falling into the familiar trap of starting from scratch, why don't you suggest copying one of the plants and building some in this country? I admit it will take leadership to carry it through, but it is more constructive than Bush's energy policy which merely advocates prolonging the working life of existing nuclear plants and no mention of new ones.

Fossil fuel consumption. Bush's only solution is to drill for more oil and from the Arctic, instead of conserving oil, gas and gasoline. His is a very simplistic and shortsighted approach. He has said absolutely nothing about the lack of need for huge pickup trucks and SUV's with their large gasoline consumption, driven mostly by one person. For good measure, both have been exempted from pollution controls by Congress in their infinite wisdom and as a gratitude for soft money. Isn't there something wrong with this picture? Isn't there a connection between usually ridiculously low gasoline prices and low fleet mileages? Again, this is not how the rest of the world operates, or were you aware of that? No wonder we consume over 20% of world's energy with only 5% of its population. As a Secretary of Energy I would ponder about that and do something about it. Drilling with wild abandon in the Arctic and burning it as fast and cheaply as we can is not the solution, merely prolonging the agony of making some serious, mature decisions. If you're still doubtful about any solution, why not start increasing the federal gasoline tax by one penny a gallon per year, until consumers decide to vote with their pocketbooks and gasoline and oil consumption will level off? It would still remain way below world market price for decades. As I said before, why should any one worry about conserving something which is kept dirt cheap by government edict?

Sincerely,

Auvo Kempainen

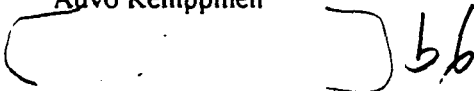

29569

b6

February 2, 2001

Vice President Richard B. Cheney
The White House
1600 Pennsylvania Ave.
Washington D.C. 20500

Dear Vice President Cheney,

Your appointment by President Bush to head a Task Force to define and implement a high priority, coherent, National energy policy is very encouraging. The degree of success of your Task Force will have a major impact on our future economy and on the quality of life in this country. The chaotic situation in California clearly demonstrates this fact.

The information emanating from the Administration appears to place the highest priority on oil from Alaska and a continuation of our present predicament of depending on more petroleum and other finite supplies of fossil fuels as a primary solution to the energy crisis. I do not believe this is your intent. Perhaps a clarification in this regard would gain stronger public support for your program.

I certainly understand the immediate need for more oil as a short-term measure for defense and such uses as transportation, heating, petrochemicals and other limited uses. However, the longer-term crisis is due to a failure to install massive electrical generation capacity and to develop alternative energy sources to decrease our dependence on fossil fuels and foreign suppliers. Oil is not the solution to the generation of large amounts of electricity, in the short or long term.

Fortunately, there are 65 nuclear power plants now operating in the United States that have a capacity to produce about 95,000 megawatts of electricity. The decision to build these plants was made by the utilities in the 1950, 1960, and 1970 decades. The U.S. was at that time the world's leader in the research, development and deployment of nuclear power. A large effective nuclear power industry was developed during this period with several major power plant designers, architect engineers, suppliers and contractors. Under the Atomic Energy Act the Utilities were required to obtain construction permits and operating license from the Regulatory arm of the U.S. Atomic Energy Commission. Construction permits and operating license issued by the commission were subject to the most comprehensive safety analysis review, detailed design standards and safety inspection regimes imposed on any industry. Operating experience to-date has demonstrated the high degree of safety and environmental acceptability of these U.S. designed plants.

France generates more than 70% of that country's electric demand with nuclear power plants. Japan has few domestic natural energy resources and has selected nuclear power as the major electrical generating source for the future. Japan has 53 nuclear units and can produce 42,369 megawatts distributed on the home islands. Many other countries of the world depend to some extent on nuclear power plants.

29570

2001-003206 2/5 A 9:57

b6

Secretary, The

From: Ries, Ken [Ken.Ries@kaiseral.com]
Sent: Friday, February 02, 2001 7:18 PM
To: Secretary, The
Subject: Energy Crisis

Spencer Abraham
Secretary, U.S. Department of Energy

Dear Sir,

My name is Ken Ries. I am a Technical Specialist working for Kaiser Aluminum Corporation at Mead, Washington. I am writing to you to express my deepest concern about the present energy crisis in the NW and BPA's past misguided management of the situation (at least to this point) and the inevitable serious impact this mismanagement will have on the Aluminum industry (and jobs, economy) in the NW unless reversed.

I just finished reading an information letter by Stephen J. Wright, acting Administrator for BPA, sent out to BPA customers and ratepayers explaining why power rates to be paid by DSI's in the 2002-2006 time period are going to increase an average of 60%!! He goes on to explain that due to "increasing costs" BPA must now "adjust" rates again and after just concluding agreements (i.e. signed contracts) with DSI's in June for a 16% increase in prices and "power rationing" that will only allow Aluminum Smelters to operate at about 40% of capacity (very inefficient!). It is apparent that the "increasing costs" are the result of BPA contracting to provide 11,000 MW of power when it only is capable of generating 8,000 MW. The extra power contracted must be purchased on the open market and (thanks to California) is in short supply and high-priced.

B.P.A.'s cavalier don't-blame-me attitude toward this whole problem really irks me! I don't quite understand how they can sign contracts for 11,000 megawatts when they can only generate 8,000! Who do they think they are? The airlines? Maybe if they stopped running all of the social programs (fish recovery, etc.) we could be paying rates more like 4 mills, which is the actual cost to generate the power. Also, I don't think they will have to worry about protecting the environment either. When they put all the NW Aluminum smelters out of business, there won't be any population left outside of Seattle to run roughshod over Mother Nature!

Also, I really don't understand how Kaiser can have a signed 5-year contract with BPA and then when, due to BPA's own mismanagement, the "costs" go up they say, "Oops, our costs went up. Your contract means nothing, it's now going to cost you 60-100% more! Sorry." If any private business tried to pull a stunt like that they would find themselves in court so fast it would make their head swim.

When you consider all that, plus the fact that the snow pack in the mountains are inadequate, reservoirs are being pulled down to historically low levels, power demand continues to grow and no new generating sources can be brought on line for at least two years and I think it is safe to assume that most, if not all of the NW smelters shut down will not be able restart until 2002 or 2003 at the earliest. What do you think is going to happen to all of the workers, salaries, export revenue and associated economic activity that will not be there? Things are looking very bleak indeed for Washington, Oregon, Idaho and Montana non-urban areas.

Unless we want to see the Aluminum industry disappear from
- the Pacific NW, BPA must:

- (1) Stop exporting our NW power resources out of the region (to California). They created their own problem and they must solve it.
- (2) Start managing the NW power resources like a business instead of a social welfare program. Keep costs down for the benefit of all.
- (3) Encourage new power generating capacity. Temper environmental radicalism with a little rationality.
- (4) Try to keep the Aluminum industry here in the NW. Aluminum is strategically vital to this region and the nation. If you want to see what happens to the Aluminum Industry when you raise electricity rates to the extreme, just look at what happened to Japan in the late 70's.
- (5) Don't let BPA use power as a political weapon (as they have been doing for the past year or two) to buy California votes, cozy up to labor unions or score political points with radical environmentalists who would like to see the NW turned into a vast wilderness wasteland.

I am aware that President George W. Bush has initiated a group to develop a comprehensive energy policy for the nation, and that you will be spearheading that effort. You have a daunting and urgent task ahead of you in that regard, especially in light of the total lack of energy policy for the past 8-years by the outgoing administration. The one policy that the prior administration appears to have implemented is converting BPA into an entity hell-bent on killing the NW economy by diverting power outside the region the dams were built for and by using BPA as an enforcement arm for the labor unions and environmental extremists. I believe that the Bush administration is committed to the principle that we must allow free markets and the laws of supply and demand to solve the long term power issues in the NW. I would also strongly encourage you to provide a reasonable transition to that concept that will preserve the Aluminum industry at the same time. Please involve the DSI's in the development of this national energy policy and insist that BPA honor its contracts and operate as an efficient business.

Thank you in advance for your timely assistance in this critical matter.

Sincerely,

Kenneth E. Ries

Kenneth E. Ries



The demise of the nuclear power plant manufacturing and construction industry in this country, beginning in the late 70's, was due to lack of a National energy policy, opposition from special interest intervenor groups, protracted public hearings and legal delays of construction all of which escalated costs beyond reason. It was not due to documented safety or environmental issues.

I trust that your Task Force will include a thorough reevaluation of nuclear generating plants as a viable alternative for satisfying a major part of the fast growing electricity demand in our society.

Best wishes for your success and thank you for serving,

Lester R. Rogers*

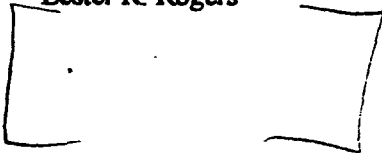

B6

*Retired
Former Director of Regulatory Standards
U.S. Atomic Energy Commission

FRED BREUNINGER

2001-003666

D. Bb

February 3, 2001

Mr. Spencer Abraham, Secretary of Energy
Energy Department
Washington, DC

Dear Secretary Abraham:

As a fellow Michigander, and as one who always voted for you, I wish to make a suggestion, which if adopted, would solve all the present and future energy problems of our nation.

I just read of the meeting in Portland, Oregon where the energy crisis was discussed. The newspaper article goes on to state, "The Bush administration has warned that the federal government will not provide a solution to the problems".

While this may be true, there is a step that the government could take that would go a long ways towards solving everything. And all it takes is a simple stroke of the pen. The step would be to sign the following suggested energy policy:

"Effective immediately I declare a state of emergency in following energy areas; electrical power, natural gas for heating, and gasoline for automobiles. All are in short supply. I urge that we immediately commence building of more power plants (including coal-fired, nuclear, and hydroelectric), exploration and drilling for natural gas, and exploration and drilling for petroleum. To achieve results quickly our primary consideration will be our nation's interest and as such, will be our first consideration. Environmental concerns will be secondary until we as a nation become self-sufficient in all energy areas".

This is the statement President Bush should sign.

To do any less is merely kow-towing to the tree huggers and the environmental wackos who are responsible for putting us in the situation in the first place.

I would like to know your feelings on this.

Sincerely,

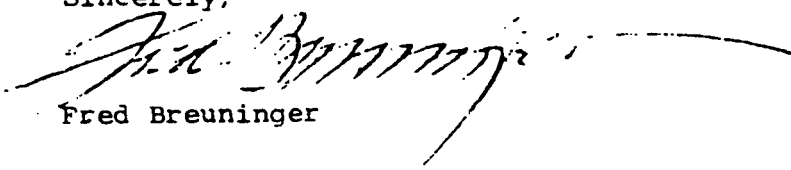

Fred Breuninger

29574

2001-003665

February 3, 2001

Secretary Spencer Abraham
Department of Energy
1000 Independence Ave., SW
Washington, D.C. 20585

Dear Secretary Abraham,

Enclosed for your information and consideration is a copy of a letter that I have sent to Vice President Cheney concerning the Task Force on the formulation of a National Energy Policy, recently announced by President Bush.

We appreciate your willingness to accept the important and difficult responsibilities that you have inherited in the Department of Energy. Our best wishes for your success in this important undertaking.

Sincerely,

Lester R. Rogers

bb

29575

b/c

2001-003666

FRED R. BREUNINGER

Bb

February 3, 2001

Mr. Spencer Abraham, Secretary of Energy
Energy Department
Washington, DC

Dear Secretary Abraham:

As a fellow Michigander, and as one who always voted for you, I wish to make a suggestion, which if adopted, would solve all the present and future energy problems of our nation.

I just read of the meeting in Portland, Oregon where the energy crisis was discussed. The newspaper article goes on to state, "The Bush administration has warned that the federal government will not provide a solution to the problems".

While this may be true, there is a step that the government could take that would go a long ways towards solving everything. And all it takes is a simple stroke of the pen. The step would be to sign the following suggested energy policy:

"Effective immediately I declare a state of emergency in following energy areas; electrical power, natural gas for heating, and gasoline for automobiles. All are in short supply. I urge that we immediately commence building of more power plants (including coal-fired, nuclear, and hydroelectric), exploration and drilling for natural gas, and exploration and drilling for petroleum. To achieve results quickly our primary consideration will be our nation's interest and as such, will be our first consideration. Environmental concerns will be secondary until we as a nation become self-sufficient in all energy areas".

This is the statement President Bush should sign.

To do any less is merely kow-towing to the tree huggers and the environmental wackos who are responsible for putting us in the situation in the first place.

I would like to know your feelings on this.

Sincerely,

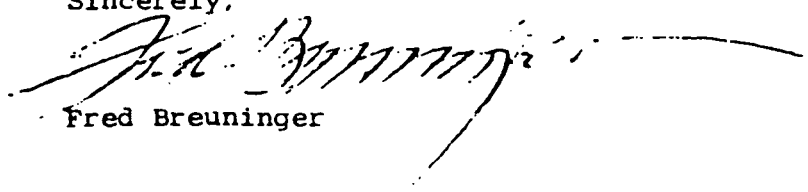

Fred Breuninger

b6

2001-003665

February 3, 2001

Secretary Spencer Abraham
Department of Energy
1000 Independence Ave., SW
Washington, D.C. 20585

Dear Secretary Abraham,

Enclosed for your information and consideration is a copy of a letter that I have sent to Vice President Cheney concerning the Task Force on the formulation of a National Energy Policy, recently announced by President Bush.

We appreciate your willingness to accept the important and difficult responsibilities that you have inherited in the Department of Energy. Our best wishes for your success in this important undertaking.

Sincerely,

Lester Rogers
Lester R. Rogers

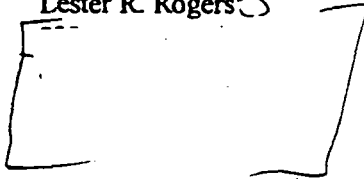

B6

29577

Secretary, The

2/5 947

003040

From: silerb@JETFUEL.COM%internet [silerb@JETFUEL.COM]
Sent: Sunday, February 04, 2001 9:19 AM
To: Secretary, The
Subject: Consumer Information Comment Form

FROM: silerb@jetfuel.com
NAME: Barry Siler
SUBJECT: Energy Policy
ZIP: 77379
CITY: BL
PARM.1: TO:the.secretary@hq.doe.gov
SUBJECT: Consumer_Information_Comment_Form
STATE: BL
TOPIC: National Security
SUBMIT: Send Comments
CONTACT: email
COUNTRY: United States

MESSAGE: This is an e-mail sent to you and the President. I have sent the attached e-mail to everyone copied on this e-mail with no response except auto-responders from some. I am also sending this to all via mail in hopes that a least one of you respond and hopefully support me in my effort to become involved in developing and maintaining a pro-active energy policy for National Defense and in support of both industry and the public. In addition to the attached prior e-mails, I would like to recommend that we

MAILADDR: BL

b6

2/5 947

003040

Secretary, The

From: silerb@JETFUEL.COM%internet [silerb@JETFUEL.COM]
Sent: Sunday, February 04, 2001 9:19 AM
To: Secretary, The
Subject: Consumer Information Comment Form

FROM: silerb@jetfuel.com
NAME: Barry Siler
SUBJECT: Energy Policy
ZIP:] B6
CITY:]
PARM.1: TO:the.secretary@hq.doe.gov
SUBJECT:Consumer_Information_Comment_Form
STATE:]
TOPIC: National Security
SUBMIT: Send Comments
CONTACT: email
COUNTRY: United States

MESSAGE: This is an e-mail sent to you and the President. I have sent the attached e-mail to everyone copied on this e-mail with no response except auto-responders from some. I am also sending this to all via mail in hopes that a least one of you respond and hopefully support me in my effort to become involved in developing and maintaining a pro-active energy policy for National Defense and in support of both industry and the public. In addition to the attached prior e-mails, I would like to recommend that we

MAILADDR: [] B6

Secretary, The

063424

From: dself@IEEE.ORG%internet [dself@IEEE.ORG]
Sent: Monday, February 05, 2001 10:19 AM
To: Secretary, The
Subject: Consumer Information Comment Form

FROM: dself@ieee.org
NAME: Don E. Self
SUBJECT: New Energy Policy
ZIP:
CITY: BL
PARM.1: TO:the.secretary@hq.doe.gov
SUBJECT:Consumer Information_Comment_Form
STATE: BL
TOPIC: Policy
SUBMIT: Send Comments
CONTACT: email
COUNTRY: USA
MESSAGE: As an energy professional, with 24 years of experience in virtually every facet of the electric power industry, I am excited about the possibility that our country may at last be developing a comprehensive energy policy. I believe I could play a key role in that process, but the job that I am seeking may not yet exist. I would like to present my vision and credentials to the appropriate parties at the DOE. Could you please advise me on the best way to proceed?
MAILADDR: BL

29580

b6

063450

Secretary, The

From: cstein@ [redacted]]
Sent: Monday, February 05, 2001 4:03 PM
To: Secretary, The
Subject: Consumer Information Comment Form

FROM: cstein@chem.wisc.edu
NAME: Carol Steinhart
SUBJECT: Energy policy
ZIP: [redacted]
CITY: [redacted]
PARM.T: TO:the.secretary@hq.doe.gov
SUBJECT: Consumer_Information_Comment_Form
STATE: [redacted]
TOPIC: Policy
SUBMIT: Send Comments
CONTACT: phone
COUNTRY: USA

MESSAGE: I am happy that the Bush administration intends to give high priority to developing an energy policy, which this country has never had. A true energy policy will plan for the long term, at least 100 years, while looking broadly even beyond that. A corollary of this is that a true energy policy will be based on designing and implementing our transition from fossil fuels to sustainable energy. It is obvious that if the Arctic oilfields are developed at all, it MUST be in the context of buying time until we
MAILADDR: [redacted]]

February 6, 2001

Secretary of Energy
U.S. Department of Energy
1000 Independence Av.
Washington, DC 20585

b6

Dear Sir:

I am writing to congratulate you and the Bush administration for giving high priority to the development of an energy policy, something this country has never had. We need an energy policy to plan for the long term (at least 100 years) and look to the even more remote future while laying the initial 100-year plan. This means urgently preparing for a society that does not run on depletable resources.

In the early 1970s I wrote three textbooks for energy and energy policy courses my husband taught at the University of Wisconsin. I objectively discussed the pros and cons of alternative sources and technologies—solar, wind, nuclear, tidal, geothermal, hydrothermal, fuel cells, coal gasification, oil shale, biomass, cogeneration, etc. All had major drawbacks, chiefly economic and environmental; some technologies were still on the drawing board. Much of that has since changed. Solar and wind energy are now economically competitive for some applications and developments in fuel cell technology leave it waiting impatiently in the wings for widespread practical applications. We have the know-how to make alternative technologies practical and economical, especially in combination with continuing improvements in efficiency and conservation.

Changes are happening, but far too slowly, because industry is seeing the light. Why aren't they happening faster? In large part because Washington has never had an energy policy and has withdrawn most of the minimal support for nonfossil–nonnuclear energy it once provided. An energy policy must, for example, provide major incentives to make and drive fuel-efficient vehicles. Incentives for improved building standards to minimize heating and cooling requirements. Incentives for rail and other forms of mass transit. Incentives for all those things and more. Provide information, because part of the problem is that the public is uninformed. As long as our intermittent energy “crises” are superficially and reassuringly attributed to corporate greed, public and private mismanagement, international politics, and environmentalists, we won't face the fact that the *root* of these so-called crises is the dwindling of conventional resources and our energy thirst, and the problems will become more frequent, prolonged, and severe until the root cause is addressed.

That's where Washington and the policy part come in. That's why it's so critically important to lay the groundwork for a sustainable energy future before it's too late. Drilling the Arctic oil reserves is a solution to *nothing*. Don't perpetrate that cruel hoax; it would be a tragedy for far more than that precious wilderness. Perhaps we will need that oil some day, to use sparingly in the transition to whatever the new energy system looks like. But not now. Please, not now. Exploit the alternatives to the Arctic, not the Arctic. Use that only if there is no alternative. Right now there is a wealth of options, much better ones.

Thank you and good luck!

Sincerely,



Carol E. Steinhart

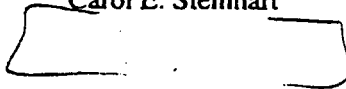

b6

Wednesday, February 7, 200

004082 2/12/01 12:50p

No Secretary Abraham, 26

No, No, No!! You've got your priorities all wrong! California has led the world into the era of power generation through clean burning natural gas! Activist on the west coast closed Rancho Seco Nuclear Power Plant near Sacramento, in 1989 by a petition vote of registered voters in ^{the} Sacramento County Municipal Utility District. The Trojan Nuclear Power Plant, north of Portland, Oregon was closed by a similar process! We knew, from day one how much reserves of natural gas lie under the province of Alberta, Canada and now the news is out on Alaska, the Yukon, and Northwest Territories!

What has been described as your "first step toward a Bush energy policy", is in the wrong direction Mr. Secretary!

Your first step should have been to (along with the FERC) stay in compliance with

29583

the Federal Power Act, who's standards clearly state that utility rates must be kept "JUST AND REASONABLE". Failing to do that, and thus breaking the law, you now dump this Energy Department offering of \$95 million in matching grants to increase efficiency and decrease pollution at coal-fired power plants.

Coal burning produces a "whole galaxy of pollutants, including nitrogen oxide, mercury, toxic metals, soot and carbon dioxide!"

No, Mr Secretary, it's time to reverse your current policy, but a cap on ^{the} wholesale cost of natural gas, and thus come into compliance with federal law.

William Dempsey

003953

Secretary, The

From: William Quapp [Bill@TetonTechnologies.com]
Sent: Thursday, February 08, 2001 12:43 PM
To: Secretary, The
Subject: Important Consumer Feedback from William Quapp!

The following letter is being sent to Department of Energy by PlanetFeedback.com at the request of William Quapp at Bill@TetonTechnologies.com.

This letter also is being sent to everyone on the cc: list provided by William Quapp. PlanetFeedback.com rates companies on customer service. Keep up the good work!

=====

February 8, 2001

TO:
Spencer Abraham, Secretary
Department of Energy
1000 Independence Avenue, SW
Washington, DC 20585

FROM:
William Quapp

B6

RE: PLANETFEEDBACK INCIDENT NUMBER 489622

Dear Sir or Madam,

Mr. Secretary, I submit the following for your serious consideration. It has been sent to a number of newspapers as a guest opinion.

The Moral Imperative for Nuclear Power

William J. Quapp, PE
I

B6

A few years ago, when confronted by persons who adopted the NIMBY (not in my backyard) philosophy regarding the construction of electric power plants, I took the somewhat smug view of "let them work and live in the dark"; I now realize that both of our views are wrong. Power shortages that are now occurring in California, cost all of us in terms of lost productivity, increased consumer prices, and the cost to heat our homes even when we live hundreds of miles away.

In my state, Idaho, natural gas wholesale costs have increased more than 132% in the last two years. As a result, the retail cost of gas to residential users by 48% since July 2000 and additional increases are likely. Our electric companies have announced price increases of around 25% because of the increased cost of power generated by natural gas.

When natural gas is used for home and water heating, the efficiency is over 90% using modern heating systems. Water heating has similar efficiencies; 70% to 90% depending upon the design and age of the water heater. In contrast, when natural gas is used in electricity production, the efficiency is about 50% for the very best and most modern gas turbine units. The inefficiency (100% - efficiency) at the electric plant is wasted heat which is rejected to the atmosphere

or to a water cooling source such as a river. Thus, the electric power companies consume great quantities of natural gas and waste nearly half of its energy value to produce electricity.

Effectively, those of us who use natural gas to heat our homes are now paying the increased cost to subsidize electric power generation. Since these increased gas costs cause millions of poor Americans to divert their income to just keep warm, this de facto energy policy is immoral. Burning of natural gas also contributes to the global warming and potential long term environmental problems.

Consequently, the new administration should focus on developing a balanced energy policy that includes nuclear energy as a major component of the National Energy Policy. In the US, we have the nuclear fuel resources for hundreds of years of large scale electric power production. Generating electricity from nuclear power will reduce demand for and lower the cost of natural gas for home heating.

There are 103 operating nuclear generation plants operating safely in the US. Production cost data from the Nuclear Energy Institute (Jan 9, 2001) for 1999, shows the benefit of having a mixed energy source option in the US. This table clearly shows the advantage of nuclear energy in terms of the production cost advantage for 1999. When the year 2000 data are in, we will see a further marked increase in the average price of electricity from natural gas. California rates for December 2000 were reported in the California Price Report on average hourly wholesale prices (a large portion of which is from natural gas) was between 22 to 31 cents/kWh for southern and northern California, respectively.

While ideally the marketplace should decide which energy source to use, I believe that is not good Federal energy policy. The free market does only what is good for the next quarter's profits. It does not invest in infrastructure for the benefit of mankind. That is the job of government. Over the last 25 years, our de facto National Energy Policy has been to ignore nuclear power and presume that natural gas would be the energy of the future. That policy clearly has its weakness; primarily one of spiraling energy costs, shortages, and greenhouse effects. As natural gas became the standard for new power generation, we have seen the surplus disappear and the prices escalate dramatically.

We need a National Energy Policy that advocates clean, safe, and economic nuclear power to be a substantial portion of our energy mix; at least 50%. We also need a regulatory policy that assures that power plant investors get a fair return on their investment and not be subject to the whims of changing state governments, harassment lawsuits, and unreasonable regulation. Widespread nuclear power generation would stabilize the demand and price for natural gas which should be used more efficiently for home and water heating as well as industrial uses.

William Quapp is a nuclear technology and waste management consultant living in

BA) and can be contacted

Sincerely,
William Quapp
Bill@TetonTechnologies.com

CC:
Larry E. Craig
Mike Crapo
Michael K. Simpson

PlanetFeedback.com is a Web site that helps consumers focus and send their feedback directly to companies. The information enables companies to improve customer service and earn consumers' long-term loyalty.

Find out more at <http://www.planetfeedback.com>.

To learn more about our commitment to customer service, go to <http://www.planetfeedback.com/manifesto>.

003953

Secretary, The

From: William Quapp [Bill@TetonTechnologies.com]
Sent: Thursday, February 08, 2001 12:43 PM
To: Secretary, The
Subject: Important Consumer Feedback from William Quapp!

The following letter is being sent to Department of Energy by PlanetFeedback.com at the request of William Quapp at Bill@TetonTechnologies.com.

This letter also is being sent to everyone on the cc: list provided by William Quapp. PlanetFeedback.com rates companies on customer service. Keep up the good work!

=====

February 8, 2001

TO:
Spencer Abraham, Secretary
Department of Energy
1000 Independence Avenue, SW
Washington, DC 20585

FROM:
William Quapp
Idaho Falls, ID 83401

RE: PLANETFEEDBACK INCIDENT NUMBER 489622

Dear Sir or Madam,

Mr. Secretary, I submit the following for your serious consideration. It has been sent to a number of newspapers as a guest opinion.

The Moral Imperative for Nuclear Power

William J. Quapp. PE *bb*

A few years ago, when confronted by persons who adopted the NIMBY (not in my backyard) philosophy regarding the construction of electric power plants, I took the somewhat smug view of "let them work and live in the dark." I now realize that both of our views are wrong. Power shortages that are now occurring in California, cost all of us in terms of lost productivity, increased consumer prices, and the cost to heat our homes even when we live hundreds of miles away.

In my state, Idaho, natural gas wholesale costs have increased more than 132% in the last two years. As a result, the retail cost of gas to residential users by 48% since July 2000 and additional increases are likely. Our electric companies have announced price increases of around 25% because of the increased cost of power generated by natural gas.

When natural gas is used for home and water heating, the efficiency is over 90% using modern heating systems. Water heating has similar efficiencies; 70% to 90% depending upon the design and age of the water heater. In contrast, when natural gas is used in electricity production, the efficiency is about 50% for the very best and most modern gas turbine units. The inefficiency (100% - efficiency) at the electric plant is wasted heat which is rejected to the atmosphere

or to a water cooling source such as a river. Thus, the electric power companies consume great quantities of natural gas and waste nearly half of its energy value to produce electricity.

Effectively, those of us who use natural gas to heat our homes are now paying the increased cost to subsidize electric power generation. Since these increased gas costs cause millions of poor Americans to divert their income to just keep warm, this de facto energy policy is immoral. Burning of natural gas also contributes to the global warming and potential long term environmental problems.

Consequently, the new administration should focus on developing a balanced energy policy that includes nuclear energy as a major component of the National Energy Policy. In the US, we have the nuclear fuel resources for hundreds of years of large scale electric power production. Generating electricity from nuclear power will reduce demand for and lower the cost of natural gas for home heating.

There are 103 operating nuclear generation plants operating safely in the US. Production cost data from the Nuclear Energy Institute (Jan 9, 2001) for 1999, shows the benefit of having a mixed energy source option in the US. This table clearly shows the advantage of nuclear energy in terms of the production cost advantage for 1999. When the year 2000 data are in, we will see a further marked increase in the average price of electricity from natural gas. California rates for December 2000 were reported in the California Price Report on average hourly wholesale prices (a large portion of which is from natural gas) was between 22 to 31 cents/kWh for southern and northern California, respectively.

While ideally the marketplace should decide which energy source to use, I believe that is not good Federal energy policy. The free market does only what is good for the next quarter's profits. It does not invest in infrastructure for the benefit of mankind. That is the job of government. Over the last 25 years, our de facto National Energy Policy has been to ignore nuclear power and presume that natural gas would be the energy of the future. That policy clearly has its weakness; primarily one of spiraling energy costs, shortages, and greenhouse effects. As natural gas became the standard for new power generation, we have seen the surplus disappear and the prices escalate dramatically.

We need a National Energy Policy that advocates clean, safe, and economic nuclear power to be a substantial portion of our energy mix; at least 50%. We also need a regulatory policy that assures that power plant investors get a fair return on their investment and not be subject to the whims of changing state governments, harassment lawsuits, and unreasonable regulation. Widespread nuclear power generation would stabilize the demand and price for natural gas which should be used more efficiently for home and water heating as well as industrial uses.

William Quapp is a nuclear technology and waste management consultant living in Idaho Falls, ID and can be contacted at Bill@TetonTechnologies.com

Sincerely,
William Quapp
Bill@TetonTechnologies.com

CC:
Larry E. Craig
Mike Crapo
Michael K. Simpson

PlanetFeedback.com is a Web site that helps consumers focus and send their feedback directly to companies. The information enables companies to improve customer service and earn consumers' long-term loyalty.

Find out more at <http://www.planetfeedback.com>.

To learn more about our commitment to customer service, go to <http://www.planetfeedback.com/manifesto>.

2001-004058 Feb 12 A 10:37 *hb*

Fax Memo

Date Feb 9, 2001

To The Honorable Spencer Abraham
Secretary of Energy
Fax 202 586 4403

From Dale Steffes
Tel 

Bf

Subject U. S. Energy Policy

Page 1 of 5

Attached are copies of a fax (4 pages) I sent to Vice President Cheney a week ago.

You may recall that I sent you our proposed 1993 National Energy Stability Policy on Jan 17, 2001, which was timed to arrive the day the Administration changed over.

I was pleased to see coverage of your address to the Senate Armed Forces Committee where you stated " and could set a maximum allowable amount for imported energy".

It would be my honor to communicate with you and your committee on this policy. Let me know how I can be of service.

Dear Spencer Abraham:

February 9, 2001

Hi! I saw you getting grilled last night on cspan. I thought you did pretty well. And congratulations on your appointment to the Secretary of Energy position! Many of the questions dealt with the lack of an energy policy, and the lack of good morale at the DOE and many other questions dealt with nuclear energy and the nuclear waste cleanup mess. As I'm sure you know, and as none of your questioners wanted to come out and say, they are essentially the same question.

I am pretty sure what the true situation is, but I wanted to get a reality check and see if you have the same thinking, or have a different view of the situation with

nuclear power, nuclear waste, and a rational energy policy.

1. Any rational national energy policy is going to have to include new nuclear

power plants, nationwide transport and safe underground storage of nuclear waste,

and the immediate cleanup of lots of toxic nuclear hazards.

2. But any mention of transporting nuclear waste, let alone NEW nuclear power

plants is political suicide because of the fear people have about it.

So: we don't have a national energy policy, because we can't make one without

committing political suicide. Because we can't have a unified policy, the morale at

DOE sucks, and the energy situation across the country is in chaos, the nuclear

waste continues to rot in barrels in railroad cars on sidings near Denver (OK, that's

hyperbole, it was there a couple of years ago...) and really dangerous nuclear waste

cleanup situations continue to fester across the country. A couple of months ago, 4

grams of plutonium were trucked through Flint on their way to Canada to a

treatment plant and people across the state practically went ballistic in their

opposition. Do you know how big 4 grams of plutonium is? About the size of a

grain of mustard seed.

I don't know about you, but I grew up on a farm, and if you didn't take care of a

problem, sometimes that brought about a real disaster. You can pile the manure up in back of the barn for a while, but sometime or other you had to take care of it, or it started to cause real problems.

I think you have an opportunity to serve the people of the United States and the world by taking the bull by the horns and solving these problems quickly.

If you emphasize that your purpose is to SOLVE THESE PROBLEMS, that left

unsolved, THESE PROBLEMS CAN KILL US, and that you welcome help, not opposition, in solving these problems.

The opposition to nuclear waste transport, and new nuclear plants is caused by fear,

mistrust and a sense of betrayal. (OK, there is also a lot of political grandstanding

that politicians can do while making statements opposing any nuclear project.) You

must admit, these are completely justified feelings, and should not be minimized,

they must be dealt with in order to solve the problems.

I think you need to invite the organized opposition, and the fearful leaders and

followers INTO the system to try and SOLVE THESE PROBLEMS. Political grandstanding needs to be neutralized by making it clear that any opposition to

solving the problems is the UNSAFE alternative. Maintaining the status quo is the

UNSAFE alternative. All it takes is one tornado to hit one above ground storage

building to make it real clear that above ground storage is unsafe.

We need to solve the problem of energy, nuclear power, nuclear waste and low

morale. Or it will kill us.

We need to deal with the fears of the people and the opposition of several radical

and not-so-radical groups before we can solve the energy problems.

I think you need to make it clear to people that you are committed to SOLVING

THESE PROBLEMS, that NOT dealing with the nuclear waste, and opposing any

transport or underground solutions is the UNSAFE action, and that you need to

have THEIR input and care in finding a solution. You may need to real

ize a loud political uproar is a good thing in this case, as it means lots of people care and want to be included in the solution of the problems. A good quarterback doesn't shrink from a challenge, but leadership leads, through overcoming a challenge.

We probably need to include people along the routes of any transport, and a wide scattering of neighbors of any nuclear plants, processing plants, and underground storage facilities in a network of radiation monitoring (simple, inexpensive geiger counters are available for distribution) possibly along with a monthly stipend, in order to convince people we are not lying to them about whatever solution is in progress, and we want them to be part of the solution. A lot of effort will need to be directed to education and to including suspicious and hostile neighbors into the effort to solve the problem.

As a people, we are afraid of nuclear power, and we have been lied to about the safety of nuclear power plants. We feel betrayed, and any solution to the nuclear power problem, the energy problem and the nuclear waste transportation and containment problem is going to have to acknowledge that betrayal, that fear, overcome the resentment, and build an architecture of trust and mutual care in order to succeed.

That is what needs to happen before we can start cleaning up the nuclear waste mess. We need to start cleaning up the nuclear waste mess before we can start talking about new nuclear power plants. We need to start talking about including nuclear power before we can have a rational discussion of the energy policy of the United States.

And all this needs to happen before we can have a national energy policy.

Is this how you see it?

B6

Sincerely,
Harmon Everett

[Redacted signature area]

B6

harmoneverett@

p.s. Many people think that the government caused all nuclear radiation and if they can prevent any nuclear activity from being in their backyard or transported through their area or state, they are keeping themselves safe. They need to be disabused of this notion and educated about normal background radiation. I suggest giving out inexpensive radiation detectors to schools and news organizations and having them available on request to interested citizens of the US, and also publishing daily "radiation" weather reports to the national news media about the background radiation in select different parts of the country to familiarize everybody about the truth about radiation. Lies, ignorance and fears about radiation allow demagogues to rally a suspicious population in opposition to our just cause. We want informed intelligent debate, not demagoguery. If people get used to the idea that there is a wash of radiation around them continually anyway, transporting some radioactivity safely through the neighborhood may not be so objectionable.

Mr. Spencer Abraham, Secretary of Energy
Department of Energy Headquarters
Forrestal Building
1000 Independence Ave. SW
Washington, DC 20585

9 February 2001

bu

Dear Sir,

I feel that after eight years of doing little, the Department of Energy (DoE) must develop a coherent energy policy that sets forth the goals and priorities of the Department. This Policy must then be implemented in accordance with an integrated plan that defines the schedules and budgets associated with each of the various tasks. This program will include such tasks as:

a) A PR program to convince the general public that gas guzzling SUV's are not cool for shopping and going to work. Hybrid electric vehicles are the "in" way to go. This will reduce the amount of oil used for transportation, and the amount of vehicle generated pollution.

b) We have the technology to convert nuclear waste into "bricks" which can be transported and stored safely. Let's do it, then mount a PR campaign to convince the public that nuclear power is clean and safe. After all, France generates about 40% of its electricity from nuclear power stations, we could do that also.

c) As a result of R&D efforts by industrial and national laboratories, equipment has been developed and tested which dramatically reduces the energy losses associated with the control and transportation of electric power. This equipment uses superconductivity to achieve energy savings. Let's use this technology.

d) Across the great southwest one sees hundreds of wind powered generators, many of which are standing still due to reliability problems. The DoE should support the reliability studies and corrective actions necessary to put those machines back on line.

e) The United States has large reserves of coal that are not as widely used for power generation as they could be because coal is considered a "dirty" fuel. We have the technology to process coal into a cleaner burning fuel, but the current processes are relatively expensive. The DoE should support further research and development of a less expensive process.

The list goes on and on, there is much to do. The foregoing are examples of tasks intended to provide the United States with more energy at lower cost, and to reduce our dependence on foreign oil which places us at the mercy of international politics.

You need someone (not a politician) with the education, the training, and the experience necessary to manage such a program. I am that person and I WANT THAT SLOT.

My background is that of a Professional Engineer with 40+ years of experience, mostly in the aerospace world where planning, budgets, and schedules are a way of life. I did spend my last years on the DoE sponsored Superconducting Super Collider Laboratory (SSCL) program in Texas. I took early retirement when that program was cancelled.

I am bored with retirement and desire to get back to what I do best – manage large, complex programs.

I am available for further discussions at your convenience and hope to hear from you.

Sincerely,

John E. Matz
John E. Matz



BL

004882 2/21/01 12:06p
February 10, 2001

Mr. Spencer Abraham, Secretary
US Dept of Energy
100 Independence Avenue SW
Washington, DC 20585

Dear Mr. Abraham,

I am writing in regard to the National Energy Policy Development Group you are heading. The development of a national energy policy is vitally important and is long overdue.

The fact that the Bush administration's best idea is drilling in the Arctic National Wildlife Refuge, however, should be embarrassing. While President Bush tries to convince Congress and the public that drilling ANWR is a super idea, PacifiCorp announced the construction of the world's largest wind farm, on the Oregon-Washington border. The Tennessee Valley Authority will soon be offering electricity generated through solar power. Citizens in Washington are finding ways to cut energy consumption by 10%. When gas prices rose quickly last year, people complained but they also increased car-pooling and use of mass transit. Organizations across the country are encouraging conservation, development of renewable resources, reduction of pollution and protection of wildlife habitat. America is trying to make real progress on energy. It would be great if the federal government would at least catch up with us, if not provide leadership.

I'm sure you have seen all of the facts showing that drilling ANWR would be short-sighted, uneconomical, and a blatant pander to the oil companies, so I will not repeat them here. I am writing to urge you to drop drilling ANWR from your list of considerations. Drilling any part of ANWR is unconscionable. ANWR should instead be designated as a national monument. I urge you to focus on the long list of progressive steps toward a responsible national energy policy, including:

- Raise vehicle fuel efficiency
- Raise fuel taxes
- Provide incentives for purchase of alternative fuel vehicles
- Encourage and support enhanced oil recovery from existing wells
- Encourage and support gas-to-liquid technology use near Prudhoe Bay (BP/Exxon/Mobil still make money)
- Remove market barriers to renewable (non-nuclear) energy.
- Switch governmental promotion and support from nuclear power to renewable power
- Support Senator Jefford's Clean Energy Act

Most Sincerely,



Rebecca L. Smith

29596

004882 2/21/01 12:06p February 10, 2001

b6

Mr. Spencer Abraham, Secretary
US Dept of Energy
100 Independence Avenue SW
Washington, DC 20585

Dear Mr. Abraham,

I am writing in regard to the National Energy Policy Development Group you are heading. The development of a national energy policy is vitally important and is long overdue.

The fact that the Bush administration's best idea is drilling in the Arctic National Wildlife Refuge, however, should be embarrassing. While President Bush tries to convince Congress and the public that drilling ANWR is a super idea, PacifiCorp announced the construction of the world's largest wind farm, on the Oregon-Washington border. The Tennessee Valley Authority will soon be offering electricity generated through solar power. Citizens in Washington are finding ways to cut energy consumption by 10%. When gas prices rose quickly last year, people complained but they also increased car-pooling and use of mass transit. Organizations across the country are encouraging conservation, development of renewable resources, reduction of pollution and protection of wildlife habitat. America is trying to make real progress on energy. It would be great if the federal government would at least catch up with us, if not provide leadership.

I'm sure you have seen all of the facts showing that drilling ANWR would be short-sighted, uneconomical, and a blatant pander to the oil companies, so I will not repeat them here. I am writing to urge you to drop drilling ANWR from your list of considerations. Drilling any part of ANWR is unconscionable. ANWR should instead be designated as a national monument. I urge you to focus on the long list of progressive steps toward a responsible national energy policy, including:

- Raise vehicle fuel efficiency
- Raise fuel taxes
- Provide incentives for purchase of alternative fuel vehicles
- Encourage and support enhanced oil recovery from existing wells
- Encourage and support gas-to-liquid technology use near Prudhoe Bay (BP/Exxon/Mobil still make money)
- Remove market barriers to renewable (non-nuclear) energy
- Switch governmental promotion and support from nuclear power to renewable power
- Support Senator Jefford's Clean Energy Act

Most Sincerely,



Rebecca L. Smith

The enclosed reports offer information and solutions for:

1. Nuclear waste reduction by converting the presently stored waste to electrical energy!!
2. Conserving world non-renewable resources.
3. Protection from diversion of Plutonium into the wrong hands.
4. National energy independence.
5. Global warming due to the burning of fossil fuels.
6. A viable replacement for our light water nuclear reactors, as they are retired from service.

Please read the enclosed reports!!!! They offer the possibility of energy for generations to come, including the benefits listed above.

I am a degreed physicist with no ties to the Nuclear Industry. I write this as a concerned citizen, with hopes it will reach enough people that have the future of the U.S., and indeed the World, in their hands, and they will have the foresight to act upon this information without political ramifications.

If you have any questions, or if I can be of any service, please contact me:

Robert A. Clarke

Tel: Fax:	
--------------	--

B6

- Copy: President George W. Bush
- U.S. Rep. Jim Gibbons
- U.S. Senator John Ensign
- U.S. Senator Harry Reid
- NV Governor Kenny Guinn
- Las Vegas Mayor oscar Goodman
- U.S Secretary of Energy Spencer Abraham

ations to come,

ered citizen, with hopes
to their hands, and they

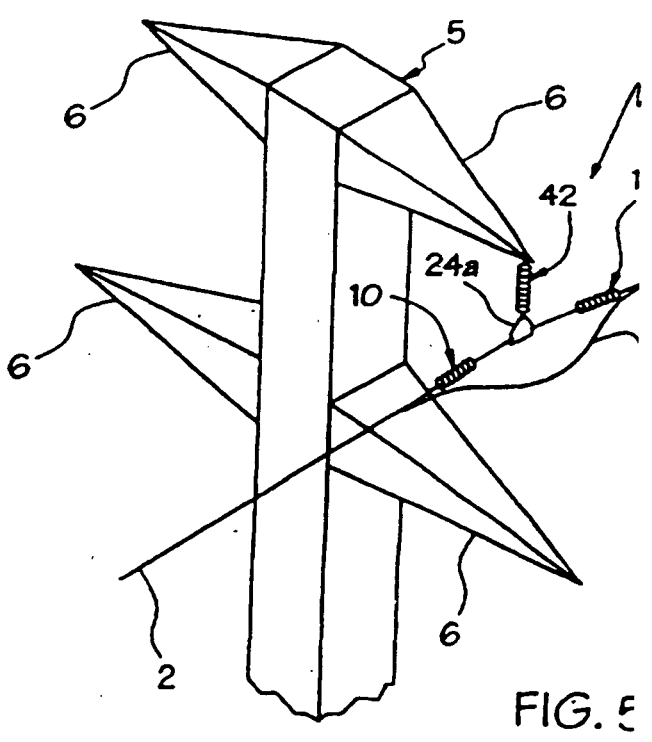
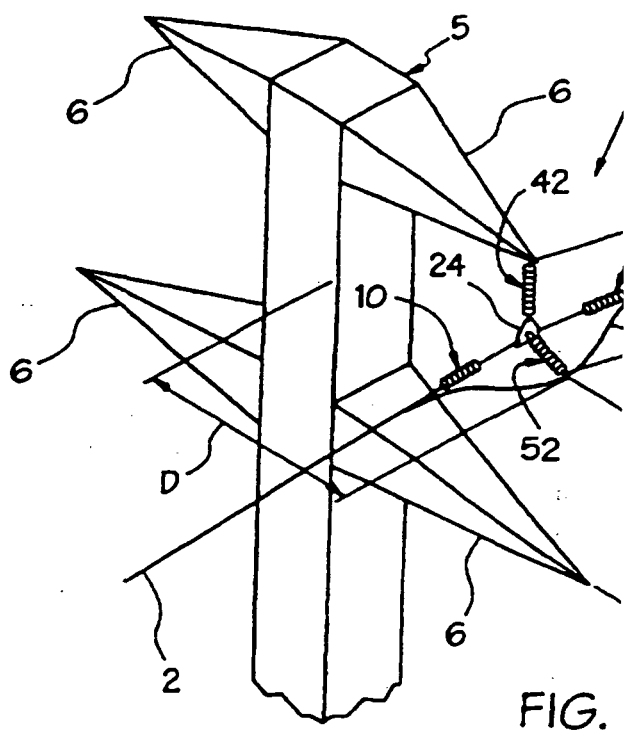

SECRETARY ABRAHAM

004020 2/11/0

enclosed reports offer information and solutions for:

1. Nuclear waste reduction by converting the presently stored waste to electric energy!!
2. Conserving world non-renewable resources.
3. Protection from diversion of Plutonium into the wrong hands.
4. National energy independence.
5. Global warming due to the burning of fossil fuels.
6. A viable replacement for our light water nuclear reactors, as they are retired service.

Please read the enclosed reports!!!! They offer the possibility of energy for gen including the benefits listed above.

I am a degreed physicist with no ties to the Nuclear industry. I write this as a cor it will reach enough people that have the future of the U.S., and indeed the World will have the foresight to act upon this information without political ramifications.

If you have any questions, or if I can be of any service, please contact me:

Robert A. Clarke

Tel:
Fax:

B6

Copy: President George W. Bush
U.S. Rep. Jim Gibbons
U.S. Senator John Ensign
U.S. Senator Harry Reid
NV Governor Kenny Guinn
Las Vegas Mayor oscar Goodman
U.S. Secretary of Energy Spencer Abraham

106

February 11, 2001

Dear Secretary Abraham,

I strongly protest the suspension of environmental laws and public input in the chaotic and unnecessary rush to build more power plants and mine more oil, natural gas, and coal. Generating capacity is NOT the root cause of this perceived energy crisis. The problem is lack of money, lack of incentives to conserve, and lack of a balanced regulatory and marketing system. I note that the majority of the world is able to function very well with much less energy per person/household than the amount used in the US.

To bypass environmental laws and public input, even temporarily, is a very bad precedent. It is also an unacceptable disservice to the current and future generations which will have to cope with the ensuing exhaustion of nonrenewable resources, polluted and toxic environment, and reduced quality of life. If you abandon common sense and sustainable development, you significantly endanger human health, the carrying capacity of earth, and our capability to survive on this planet.

I urge you NOT to waive environmental laws and public input in the development of a local, state or national energy plan.

Instead, I urge you to comply with the publicly supported environmental laws and to seriously consider citizen input. I also ask you to strongly press for conservation incentives. These incentives could include: increased prorated energy rates, rolling or timed blackouts of residential areas during the day, energy police [there is no obvious conservation occurring in my neighborhood - lots of christmas and regular lights are on all night], and special exemptions to rate increases for essential services such as hospitals, farmers (where the energy is key in saving a crop), and fire/police stations.

Your ability to look beyond the immediate "crisis" and to consider the long-term sustainability of this country, its people, and the entire Earth, would be greatly appreciated.

Sincerely,

Laura Fujii
Laura Fujii

Carter, Douglas

From: Patricia Hoffman
Sent: Wednesday, February 14, 2001 12:35 PM
To: Carter, Douglas
Subject: Re: Electricity outline for the WhiteHouse



Electricity outline
item#1.wpd.

more input. pat

----- Forwarded by Patricia Hoffman/EE/DOE on 02/14/2001 12:30 PM -----



Joseph Galdo
02/14/2001 12:29 PM

To: Patricia Hoffman/EE/DOE@DOE
cc:

Subject: White House Electric Outline

Attached is my input for item #1. There is a little overlap with Phil's

Carter, Douglas

From: Patricia Hoffman
Sent: Wednesday, February 14, 2001 11:43 AM
To: Carter, Douglas
Subject: Re: Electricity outline for the WhiteHouse



FE supply Vp
document.wpd

this is what I have to date.

[

]

b(5)

005163 2/26/01 9:07a

Secretary, The

From: Secretary, The
Sent: Friday, February 16, 2001 1:03 PM
To: Secretary, The
Subject: Consumer Information Comment Form

b(6)

FROM: b(6)
NAME: Nita Spracklen
SUBJECT: resume
ZIP: b(6)
CITY:
PARM.1: TO:the.secretary@hq.doe.gov
SUBJECT:Consumer_Information_Comment_Form
STATE: OH
TOPIC: Policy
SUBMIT: Send Comments
CONTACT: email
COUNTRY: USA

MESSAGE: February 16, 2001 U.S. Department of Energy 1000 Independence Avenue, SW Washington, DC 20585 Dear Sir: You will discover from the enclosed resume that I have a results-oriented background with extensive experience working in the trenches of deregulation of the electricity and natural gas markets. I am very interested in offering my expertise where ever it is needed in the development of a National Energy Policy. My skills and talents have been applied successfully in the deregulated MAILADDR: 958 Hidden Ridge Drive

*nothing attached
2/21/01
BMM*

29606



Department of Energy
Washington, DC 20585

February 21, 2001

2001-001765

Dr. Steven C. Barrowes

BB

Dear Dr. Barrowes:

Thank you for your letter of January 12, 2001, to Secretary Abraham regarding nuclear power and our Nation's energy policy. Your letter was forwarded to the Office of Nuclear Energy, Science and Technology for reply.

As you stated in your letter, you believe nuclear power should have a prominent role in our national energy policy. I concur. For this to happen, it is vital that existing nuclear power plants continue to operate economically and safely. In addition, the Department of Energy (DOE) is working to ensure that nuclear power remains a viable energy alternative for power generators in the future. A number of initiatives at stimulating new investments in power generating capacity across the Nation are being explored. I assure you that nuclear power is one of those options.

Through the license renewal process for current nuclear plants, the Nuclear Regulatory Commission (NRC) has demonstrated a predictable and reasonably bounded approach that can lead to the relicensing of almost all of the currently operating nuclear units. Further, DOE has worked closely with NRC and the nuclear industry, and as a result of our collaborations, there are today three different standardized plant designs certified for construction by NRC. NRC has adopted a risk-informed approach that should allow for greater regulatory efficiencies in the future, and DOE is beginning to work with NRC to address issues associated with licensing future nuclear power plants. As for reimbursements to the industry from the Carter era moratorium on reprocessing, this matter has been settled in the courts.

For more specifics on current DOE policies and activities, I encourage you to explore DOE's Strategic Plan at the Web site www.energy.gov and the Strategic Plan for Nuclear Energy at www.nuclear.gov.

Thank you for sharing your ideas and concerns.

Sincerely,

Gail H. Marcus
Principal Deputy Director
Office of Nuclear Energy,
Science and Technology



Printed with soy ink on recycled paper

29607



Department of Energy
Washington, DC 20585

b(5)

February 23, 2001

MEMORANDUM FOR THE SECRETARY

FROM: Margot Anderson *Margot Anderson*
Acting Director
Office of Policy

SUBJECT: Response to letter from Wilma Delaney, V.P. for Government
Relations, Dow Chemical Co.



Printed with soy ink on recycled paper

29608

2001-005592 2/28/01 2:47

b6

005592

Secretary, The

From: C B6
Sent: Tuesday, February 27, 2001 8:36 PM
To: Secretary, The
Subject: Policy

FROM:
NAME: Doug Stockel
SUBJECT: Policy
ZIP:
CITY: I
PARM.1: TO:the.secretary@hq.doe.gov
STATE:
TOPIC: Nation's Energy Plan
SUBMIT: Send Comments
CONTACT: email
COUNTRY: USA

MESSAGE: Please support a United States Energy Policy that encourages research and development of alternative energy sources, especially ethanol and wind turbines. As we look to become more self-sufficient and less dependent on the middle east when it comes to energy, we need to encourage and support the efforts to develop alternative energy sources here in the US. Drilling for oil on US land is NOT the best solution. We will be right back where we are today in just a few years. In page A2 of

the Tues,
MAILADDR:

005763 3/2/01 12:13p

b6

Secretary, The

From: []
Sent: Wednesday, February 28, 2001 11:00 AM
To: Secretary, The
Subject: Policy]

FROM:] b6

NAME: Norman Haan

SUBJECT: Policy

ZIP:] b6

CITY:] b6

PARM.1: TO:the.secretary@hq.doe.gov

STATE:

TOPIC: New Sources of Energy

SUBMIT: Send Comments

CONTACT: email

COUNTRY: U.S.

MESSAGE: It appears to me that the Clinton administration had no energy policy resulting in shortages which are costing us heavily. I would like to see efforts to develop new sources of energy. We can get beyond the dependence on oil. What about garbage, agricultural products, nuclear waste, sea water? There are many other things. I am not a scientist, but we have tremendous technology today discovering new avenues and products. Car efficiency can also be increased very much. Give us a good energy policy and

MAILADDR:] b6

Secretary, The

From: Steven Kreek
Sent: Wednesday, February 28, 2001 9:55 AM
To: Secretary, The
Subject: national energy policy initiative



tmp.htm



February_28.pdf

Dear Mr. Secretary:

Many scientists have given long, hard, thought to the issue of power infrastructure in the United States. Please find some ideas that draw their origin from this community that might help in your efforts to form a National Energy Policy. I would be most pleased if you would consider seriously this input.

Increase available power to the National grid:

1. Solar panels on the roofs of homes in the sun belt. For an average home, 6-10 thousand dollars will install sufficient solar collectors to power the entire home during the day and will result in power being RETURNED to the grid by the user, reducing their power bill. In the evening, the user will rely upon the local grid and power producers, however, the consumption will be much reduced. A user could easily make money in this process. Provide incentives for people to install these.
2. Make the hard choice and increase reliance on non-fossil-fuel and domestic sources of power. These include solar, hydro, wind, AND nuclear. Not only will this increase the available power to the National grid but also MEET our international obligation to reduce fossil-fuel-produced greenhouse gases. The reduction in greenhouse gas emissions as well as the increased reliance on other renewable sources should appease many of the environmental groups. (Reminder, nuclear energy is renewable in that it can produce its own fuel. In addition, some limited reprocessing would permit extraction of HIGHLY valuable and rare medical radioactive isotopes for cancer, thyroid and other treatments.) Make this hard choice.

Reduce reliance on foreign sources:

3. Decrease reliance on non-US sources. While increasing the available electrical power to the grid via points 1 and 2, natural gas sources (our own) become available for such things as hybrid automobiles. Provide significantly increased incentives to use alternate powered vehicles and mandate that current gas stations be provided resources by the parent oil companies to provide distribution as part of their service (rapid chargers, natural gas). The use of gas-electric hybrid vehicles is a likely solution.

Reform the regulatory process and reduce NIMBY:

4. Reduce and streamline the regulatory process of getting approval to build new plants. Provide incentives to the local communities to build plants to reduce the "not in my back yard" (NIMBY) syndrome. People seeing their schools and cities benefit from a yearly "bonus" for having a local power plant (in the form of additional resources for their school or the like) would be much less likely to suffer

NIMBY.

Educate:

5. Make nuclear power less ominous. Provide information on the use of nuclear power in other countries, such as France, and the improvements made over the 1960s technology used in Chernobyl and Three-Mile Island. People are afraid and they should not be. The ONLY way to solve that is for an organized government-driven education program.

I thank you for taking the time to read this. I really believe that some of these ideas should be incorporated in the US National Energy policy and would be more than willing the help with such. I have provided these ideas to you as a US Citizen.

Sincerely,

Steven A. Kreek
A concerned Livermore Laboratory scientist and US Citizen

Secretary, The

b6

005740

From: ADEMAIN
Sent: Wednesday, February 28, 2001 4:43 PM
To: Secretary, The
Subject: Renewable Energy

ADEMAIN

] B6

FROM: ADEMAIN]
NAME: ANDY DEMAIN]
SUBJECT: Renewable Energy]
ZIP:]
CITY:]
PARM.T: TO:the.secretary@hq.doe.gov]
STATE: OH]
TOPIC: INVESTMENT INTO RENWABLES]
SUBMIT: Send Comments]
CONTACT: email]
COUNTRY: USA]
MESSAGE: DEAR MR. SECRETARY, I WOULD URGE YOU, AS YOU DEVELOP
YOUR ENERGY PLAN FOR THE NEW ADMINISTRATION, TO PUT IN PLACE
INCENTIVES FOR R & D AND USE OF RENEWABLE ENERGY RESOURCES.
ENVIRONMENTALLY THIS IS THE ONLY COURSE THAT MAKES SENSE. ALSO,
IF WE CONTINUE TO RELY ON FOSSIL FUELS WE ARE LEAVING FUTURE
GENERATIONS WITH HUGE PROBLEM WHEN THE EARTH RUNS OUT OF FOSSIL
FUEL. SINCERELY, ANDY DEMAIN]
MAILADDR:]

BS
DOE

Todd Abbotts

March 5, 2001

President Bush
The White House
1600 Pennsylvania Avenue N.W.
Washington, DC 20500

Dear President Bush,

I am writing to express my concern, and disappointment, with the recently released energy plan.

First, allow me to say that I believe the "energy crisis" we can hear so much about is greatly exaggerated. I have repeatedly seen news reports indicating that a sufficient supply of energy presently exists. The shortfall at the consumer level appears a likely consequence of delivery not production. Even California's distress seems more the result of corporate greed, poor regulation (or lack thereof), and excessive demand, than a shortage of production.

Consequently, your energy plan relies far too heavily on increased production and far too little on conservation. You would have us hand our public lands over to the same company's that are reporting record profits as of late (according to ExxonMobil's last quarterly earnings report, and the record profit stated therein, they also seem to have no trouble with our nation's current supply and demand status). This, in order to put more fuel into excessively inefficient SUV's, trucks, and vehicles of all kinds. Additionally, the short-term issue of exorbitant prices is not addressed. Even our homes have not been brought forward to the efficiency standards that are technologically obtainable. Sacrificing the Artic National Wildlife Refuge (ANWR) to provide fossil fuels to this unnecessarily gluttonous appetite is unreasonable.

If we could (though, I strongly doubt it's possible) to drill, mine, and nuke our way out of the current energy shortfall it would come at a horrible price to our public health, and the environment. Your plan would ask us to destroy environmentally sensitive public lands while at the same time generating more pollution in the form of CO2 and other greenhouse gases, nuclear waste, and toxic spillage.

I believe the better way to solve our country's energy problems lie in putting forth an energy plan that places stronger emphasis on energy conservation and renewable power. Much more aggressive measures than the 42 listed within your plan. The U.S. Department of Energy has indicated that this alone can meet 60% of our nation's needs. Producing vehicles with a fuel economy only 3 miles to the gallon better would, in itself, over ten years save more oil than ANWR is likely to generate. Developing and implementing a more balanced strategy would even answer today's energy concerns sooner.

Please consider supporting a plan that is a more realistic, balanced, and environmentally sound solution to our nation's energy needs than has been put forth by your administration.

Yours,



Todd Abbotts

2001-006158 3/7/01 2:26

006158

Secretary, The

From: C
Sent: Monday, March 05, 2001 1:50 PM
To: Secretary, The
Subject: Nuclear Energy

b6

FROM:
NAME: john Coolidge
SUBJECT: Nuclear Energy
ZIP:
CITY:
PARM.1: IO:the.secretary@hq.doe.gov
STATE:
TOPIC: Energy Policy
SUBMIT: Send Comments
CONTACT: email
COUNTRY: usa

MESSAGE: I understand that an energy policy is under review. I urge that Nuclear Power be given a strong place at the table. We have allowed a small, liberal and I must say, left-wing minority to dictate our policies towards nuclear power. Ever since Three-Mile-Island the government has been in a defensive posture it reminds me of the Tet Offensive in the Vietnam war. We won the battle but the news medium distorted and swayed the American people against the war on the basis of our "defeat". Similarly
MAILADDR

J B6

2001-006148 3/7/01 2:25

006148

Secretary, The

From: Secretary, The
Sent: Tuesday, March 06, 2001 12:23 AM
To: Secretary, The
Subject: Select

bb

FROM: Mich Engleman
NAME: Mich Engleman
SUBJECT: Select
ZIP:
CITY:
PARM.1: TO:the.secretary@hq.doe.gov
STATE:
TOPIC: Fuel cells
SUBMIT: Send Comments
CONTACT: email
COUNTRY:

bb

bb

bb

MESSAGE: In the emerging comprehensive energy policy that I have heard President Bush and Vice President Cheney speak of, what comparative effort will be made to seek out clean and renewable energy sources? Can and will this government encourage the development of a fuel cell industry while keeping its oil and utility business lobbyists happy? Was Mr. Cheney indeed an executive for an oil company in between his public service years? Seeing that we have never performed an experiment on our Earth to truly understand

bb

29617



Department of Energy
Washington, DC 20585

b6

March 6, 2001

Mr. I. Arthur Hoekstra, PE

[] b6

Dear Mr. Hoekstra:

Thank you for your recent letter, which offered recommendations on how to increase the use of garbage as a source of energy for the generation of heat and electricity.

As you know, one of President Bush's first acts was creating a National Energy Policy Development Group, headed by Vice President Cheney, to help the private sector and government at all levels, promote dependable, affordable, and environmentally sound production and distribution of energy for the future. This group includes the Secretary of Energy, as well as the Secretaries of the Treasury, Interior, Agriculture and Commerce Departments, the heads of the Federal Emergency Management Agency, the Environmental Protection Agency, the President's Deputy Chief of Staff for Policy, and the Assistants to the President for Economic Policy and Intergovernmental Affairs.

The group will consider the ideas and recommendations of consumers, businesses, and independent experts on how best to address the broad range of energy issues now facing the Nation, including rapidly rising costs for natural gas, electricity supply and price problems in the West and the increasing dependence of the United States on imported oil. Your specific suggestions will be made known to participants in this process.

Thank you for writing.

Sincerely,

Margot Anderson
Acting Director
Office of Policy



Printed with soy ink on recycled paper

29618

Carter, Douglas

From: Carter, Douglas
Sent: Wednesday, March 07, 2001 5:13 PM
To: Kripowicz, Robert; Rudins, George; Porter, Robert; Braitsch, Jay
Cc: Kane, Robert
Subject: NEP: Draft C&PS Options papers

Attached are the 6 requested options papers for C&PS.

I have not included the [] b5

I have not incorporated three items which we may wish to include:

] b5



SequestFE.doc



4PollutantFE.doc



DemoFE.doc



IncentivesFE.doc



Elec NewCoal.doc



Elec ExistingCoal.doc

Doug Carter (FE-26)
US DOE
Washington, DC 20585
202-586-9684

[This email uses 100% recycled electrons.]

10-1-01

cons

options papers

66

[Rubin D. Cooley]

March 8, 2001

The Honorable Richard G. Lugar
United States Senator
306 Hart Senate Office Building
Washington, D.C. 20510-1401

Dear Senator Lugar:

Ref: Ltr to you Senator, April 8, 2000, "The New Petroleum"

My Foreign Affairs, January/February 1999, issue, so dog-eared and soiled, I now circulate only my photo copies of your essay, "The New Petroleum"

It is written that the Bush budget includes, "...a sharp cut for energy-efficiency and renewable-energy research."

At one point during the campaign, I read that candidate Bush would cut out funding for ethanol research. Whether direct government funding for R&D costs or playing games with tax dollars generates the greater benefit is beyond my math ability.

Given that Texas is home for a large number of oil drilling equipment firms and that the Bush family is satisfied with the petroleum industry's future revenue generating possibilities from oil leases in the Arctic National Wildlife Refuge in Alaska, it is safe to assume that for political reasons, and self interest, it would be counterproductive that the administration support an alternative-energy program at this time.

With California's energy distribution fiasco, and the cry for more distribution lines and oil-fired generating plants, it becomes ever more certain that, "The United States cannot wait for the next energy crisis to marshal its intellectual and industrial resources." Drilling in Alaska for a quick solution to either of these problems is excessively optimistic. I feel that the president's energy plans for the future will lead to disaster unless people of knowledge, foresight, power and influence succeed in bringing about a change in the types of fuel we burn to generate electricity.

Your knowledge, your foresight, your place in our society is all we can hope for. We cannot do it alone. Your excellent essay, "The New Petroleum", is the most convincing piece I have ever read on the subject. I'm a Washington state resident and, of course, my vote must be cast, if cast at all, for candidates of our state, but the nature of this energy thing affects us all, if not the entire world.

29632

I hope you and your staff will continue to work toward educating the American people...if nicotine is injurious to your health... "Our growing dependence on increasingly scarce Middle Eastern oil...." is far more deadly. We need another George Orwell Novelist to do a frightening, "Two Thousand Eighty Four" thriller---a bit more engrossing than non fiction, boring reality---a thriller to seize and take hold of our impaired, attention deficit readers' popular imagination, to drive home the possible catastrophic implications of world wide dependence on Middle Eastern oil.

Our country needs your help, Senator Lugar.

Sincerely,

Rubin D. Cooley

c.c. Spencer Abraham,
Secretary of Energy

b6

Rubin D. Cooley

March 8, 2001

The Honorable Spencer Abraham
Secretary Of Energy
Department Of Energy
1000 Independence Avenue SW

Dear Secretary Abraham:

Will you please briefly comment on your views, your philosophy concerning the country's energy policies? In particular, will you address our concerns, both clearly addressed, and to those implied in the letter sent to Senator Lugar?

Thank you, Mr. Secretary.

Irina Cooley
R.D. Cooley
Rubin D. and Irina G. Cooley

P.S. Highly recommend that you read Senator Lugar's essay:
"The New Petroleum", Foreign Affairs, January/February, 1999.

We will appreciate your comments.

bb

March 12, 2001

Secretary of Energy Spencer Abraham
U.S. Department of Energy
1000 Independence Ave., SW
Washington, DC 20585

Dear Secretary of Energy Abraham:

I have high hopes for the new administration, and I feel it can be a great administration if it realizes the opportunity it has to proceed with vision on the country's energy policy. While America should have made efforts to become energy independent right after the "energy crisis" of 1973, I don't feel that this lack of initiative means that we should now drill for oil in the Arctic National Wildlife Refuge or in other pristine natural areas.

Americans want to save land of unspoiled natural character. These areas should be off limits to the disturbances of man and are of increasingly greater value as the country grows in population and development. Wild places should be large to preserve viable wildlife populations and because large unfragmented tracts are the true character of wildness. The administration I hope will uphold these values; for public lands are our best chance to maintain the integrity of nature itself on this continent.

I ask you to consider how incredible America's landscape is.

Though the subject of energy independence is one of national security, I feel that with real vision our nation can meet its energy needs and still protect this wonderful country. We don't believe the oil industry experts who say oil extraction can be accomplished without destruction of sensitive areas--any human activity changes these special areas.

Therefore, I ask you to embark on a courageous path of showing real leadership to conserve energy--our citizens need your inspiration to turn off unused lights, shut windows so the heat doesn't escape from a building, purchase energy-efficient cars and appliances. I'm referring to great leadership, like during World War II, when we faced the challenge with unity and purpose. This administration could rally the people on a grassroots campaign to accomplish the goal of *not wasting energy*. The work of Amory Lovins and others demonstrates that energy efficiency alone can get our nation out of the jam we're in. Add to that the development of alternative sources of energy, and America could leave its wild open spaces alone for future generations to appreciate.

Sincerely,

James Stone
James Stone

Secretary, The

From: []
Sent: Tuesday, March 13, 2001 10:42 PM
To: Secretary, The
Subject: Policy

b6

FROM
NAME: Dr. John Hutton
SUBJECT: Policy
ZIP:
CITY:
PARM.1: TO:the.secretary@hq.doe.gov
STATE: OH
TOPIC: carbon dioxide emissions
SUBMIT: Send Comments
CONTACT: email
COUNTRY:

MESSAGE: Dear Mr. Abraham, Greetings. Congratulations on your appointment, and I hope all is well so far in this rather tumultuous term. I am writing to pass along the text from an original letter I sent President Bush today regarding his about-face on his campaign pledge to seek a uniform, federal role in regulating carbon dioxide emissions from power plants in national energy policy. To say the least, we were dismayed and outraged, and hope you will do what you can to redirect federal energy policy towards a
MAILADDR:

No Attachment
provided

March 14, 2001

Erik Miller

b6

United States Department of Energy
Secretary Spencer Abraham
1000 Independence Ave., SW
Washington, DC 20585

Dear Secretary Abraham,

The energy crisis affecting this country, and more particularly the west coast, is no more a crisis than a hangover is. Our problems with energy prices and energy availability is due completely to our gluttony, our over indulgence, our irresponsible disregard for our actions.

I find it disgraceful that the leaders of our country are so willing to abandon long term preservation of our environment, the health of our environment, our ecosystems, and ultimately our personal health, to alleviate our energy hangover, to pander to our adolescent-like irresponsibility.

It is time for the leaders of our country, for you, to act like leaders and plan for the long term. We need an energy policy that has a long term objective, a 20 year objective.

The policy must have objectives that encompass the things that are important to the prosperity of our country, our livelihoods, our personal health, and the health of our environment.

This long term plan must address;

Diversity of energy sources,

Developing new energy sources,

Clean, non-polluting energy sources, *(the inability to address the detoxification of the waste from nuclear power plants makes such nuclear energy a very, very poor, short sighted choice for energy generation)*

Organic/renewable sources such as ethanol, organic petroleum,

Fuel Cell technology,

Solar,

Wind.

This long term plan must address;

Wise use of energy, energy conservation,
Investing in mass transportation, *(trains, and particularly electric trains can be powered from sources of energy that will never usable on aircraft),*
Investing in the development of new "engines",
Investing in the development of new lighting technologies, new heating technologies.

It is time for the leaders to start thinking 15, 20, 40 years out. Set up the foundation, get moving on the investment, the research that will help future generations address these issues.

Start thinking about future generations, not about future elections.

Sincerely,



Erik Miller



Department of Energy
Washington, DC 20585

May 15, 2001

Mr. John Castle

b6

Dear Mr. Castle:

I am responding to your fax of March 27 to Secretary Abraham that requested information on national energy policy plans, energy subsidies and nuclear power plants.

I am enclosing a copy of the most recent national energy policy plan, the Comprehensive National Energy Strategy (1998). I am also enclosing a copy of "Powering the New Economy," issued by the Department in September, 2000. Copies of the other energy policy plans that you requested are no longer available.

A 1999 report by the Department's Energy Information Administration provides an assessment of government interventions and subsidies related to energy. A copy is accessible at the following webpage: <http://www.eia.doe.gov/bookshelf/finance.html>

For the information on U.S. nuclear power plants, please contact the Nuclear Regulatory Commission. Their webpage is: <http://www.nrc.gov/>

I hope this information is helpful. Thank you for writing.

Sincerely,

Margot Anderson
Acting Director
Office of Policy

Enclosures



Printed with soy ink on recycled paper

29640

b6

Ronald Marsico

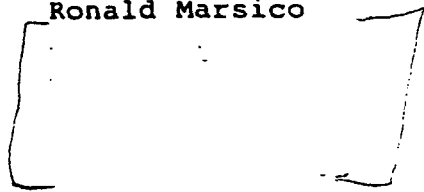

March 16, 2001

Hon. Richard Cheney
Vice-President of the United States
The White House
1600 Pennsylvania Avenue
Washington, D.C.
20500

Subject: California Electricity Problems-- And Potential
Use Of U.S. Patent No. 4,686,325 To Help Mitigate
Certain Transmission Line Power Transfer
Bottlenecks.

Dear Mr. Vice-President,

On Jan. 27, 2001, I wrote to Hon. Spencer Abraham and Governor Gray Davis and included a significant package of supporting materials concerning the subject Patent which is entitled "CATENARY SAG ADJUSTMENT USING ADDED WEIGHTS" (copies of above included for your information). I also sent a follow-up letter today asking what I can do to initiate a dialogue on this innovative technique.

Without repeating the details included earlier, this Patent has the potential to increase the power-carrying ability of certain existing clearance-limited and sag-limited electrical transmission lines in a cost-effective, timely, and environmentally sensitive manner to help alleviate various existing transmission line bottlenecks! These limitations exacerbate the basic generation shortage problems in various regions of the country.

Since President Bush has recently appointed you to lead a high-level Task Force to develop a national energy policy (which necessarily includes the component of electrical transmission problems), I request that you and/or your Staff review these Patent Materials and make this information available to your Task Force for their consideration.

I hope that a review of this Patent leads to some solutions

to the transmission line inadequacies that worsen the overall energy problems. Certainly, potential usage of this Patent, which effectively "squeezes" additional power transfer capacity out of existing lines warrants serious study.

By copy of this letter, I am also taking this opportunity to inform Hon. Billy Tauzin, Hon. Christy Todd Whitman, Hon. Curt Hebert, executives of three of California's major utilities and others about this Patent by also furnishing them with the package of detailed Patent information.

Thank you for your consideration of my initiative and I look forward to being contacted by interested parties to begin a dialogue on this matter. Also, I have a small model that demonstrates the basic workings of this Patent and I would be happy to meet with appropriate people to personally explain the benefits and usage of the Patent.

Respectfully,

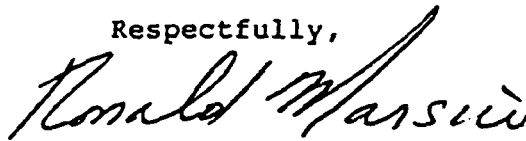

Ronald Marsico

Enclosures:

Copies: Hon. Curt Hebert--FERC Chairman
Hon. Gary Locke--Governor of Washington
Hon. Billy Tauzin--Chairman of House Energy Comm.
Hon. Christy Todd Whitman--EPA Administrator

Keith Bailey--President & CEO, Williams Company
Steve Baum--President & CEO, Sempra Energy
John Bryson--President & CEO, Edison International
William Hecht--President & CEO, PP&L Resources
Joe Perkins--President & COO, Reliant Energy
Charles Robinson--Calif. Independent System Operator
Jeffrey Skilling--President & CEO, Enron
Bruce Werthinton--Chief Counsel, PG&E

Bruce Freimark-- Co-Inventor and Patent Co-Owner

March 16, 2001

President George W. Bush
The White House
Washington, D.C. 20500

Subject: *A Legacy for the George W. Bush Administration*

Dear Mr. President,

Here is a legacy for you and your administration to leave for generations to come. Initiate an energy plan that will make our country independent of foreign oil and gas within the next ten years. It is possible and here's how.

Make a mandatory plan to require 60 mile per gallon personal vehicles only to extend our own oil resources - Implement a firm 10 year plan to bring renewable energy sources to full operational status and show how much of each type of is required. Maximize the use of wind energy where practical, all hydroelectric and geo-thermal potential where economically feasible and biomass fuel products in balance with food producing capability.

Your plan should include specific underwriting of solar farms to produce electricity as well as storable and shippable energy forms such as hydrogen. The electrical output should be connected to an all-states national grid and be sun following, not battery and grid backup connected. Require national refitting of all coal burning power plants to strict clean emission standards.

Make firm plans to solve the radioactive waste problems in 10 years or put nuclear fission power plants to bed - The same for fusion. Revitalize our national railroad systems. Develop and initiate use of new fuels for aircraft.

Your plan should consider energy rationing and energy saving credit systems for consumers, if necessary, to achieve the independence goal. I am convinced the ten-year concept is feasible and I will be attempting to show the effects of such a plan in a follow-up report.

Sincerely yours,

R. H. Horton

Telephone: 6

E-mail:

LG

cc: Vice Pres. Richard Cheney, Sec. Of Energy Spencer Abraham, Sec. Of Defense Donald Rumsfeld, and Dir. Of NREL Admiral Richard Truly.
K. G. Hagen, G. H. Sawtell and Wm. A. Horton

2001-007321 3/19/01 9:45

b6 007321

Secretary, The

From: []
Sent: Sunday, March 18, 2001 11:05 AM
To: Secretary, The; senator@stabenow.senate.gov%internet; senator@levin.senate.gov%internet; Lynn.Rivers@mail.house.gov%internet
Subject: Energy Policy



tmp.htm

March 18, 2001

To whom it may Concern,

I am writing to express my worries about the present executive administrations energy policy. I have grown up hearing about the limits of fossil fuel. My grandchildren or great grandchildren may not have the luxury of half a century to postpone considering the inevitable loss of this resource. I beg you, as a matter of national security, please subsidize the production of solar panels, fund fuel cell research, and promote the disciplined and super cautionary use of nuclear power.

Sincerely,

Donald W. Roullier III
Father, Son, Citizen, IT Operations Manager

[] B6

29645

March 16, 2001

Spencer Abrams
Secretary of Energy

Dear Mr. Abrams,

I just recently heard your stimulating, over-arching speech to the U.S.
Chamber of Commerce on the energy policy of the Bush Administration.

I would appreciate receiving a copy of the speech.

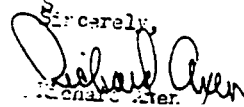
Sincerely,

Richard A. Ayen

bb

2001-007346 3/19/01 9:46

b6

007346

Secretary, The

From:
Sent: Sunday, March 18, 2001 10:55 AM
To: Secretary, The
Subject: Policy

] B6

FROM: Don Roullier] B6
NAME: Don Roullier
SUBJECT: Policy
ZIP:
CITY:
PARM.1: TO:the.secretary@hq.doe.gov
STATE:
TOPIC: Energy Policy
SUBMIT: Send Comments
CONTACT: email
COUNTRY:

MESSAGE: March 18, 2001 To whom it may Concern, I am writing to express my worries about the present executive administrations energy policy. I have grown up hearing about the limits of fossil fuel. My grandchildren or great grandchildren may not have the luxury of half a century to postpone considering the inevitable loss of this resource. I beg you, as a matter of national security, please subsidize the production of solar panels, fund fuel cell research, and promote the disciplined and super cautionary use

MAILADDR: [] B6

March 19, 2001

President George W. Bush
1600 Pennsylvania Avenue, NW
Washington, DC 20500

THE LARSENS

(b)(6)

Re: Agriculture and energy policies

Mr. President:

I would like to take this opportunity to pass on some thoughts and ideas about our agricultural and energy policies. To help add some credibility to these thoughts and ideas, I think that you should know that I am a retired petroleum engineer and manager with Chevron Corporation. I also grew up on the farm in South Dakota and currently own and operate a tree farm/nursery in eastern South Dakota. All of my life I have been involved in either farming or the petroleum business or both.

As I look at my expenses for my home and business and talk with my farming friends and relatives one thing continues to be clear to me. We are at or are heading towards a crisis in both the agricultural and energy sectors of our country and the two are tied together.

Let's start with the energy sector. Hydrocarbons are not a renewable resource, yet we utilize them like we will never run out. The U.S. continues to import a larger and larger share of its petroleum needs year after year. Maintaining a steady supply of this product in turn increases our military expenses higher and higher with less and less of a guarantee that our foreign supply will be available. Many talk about the vast supplies of untapped oil and gas at ANWR yet we currently ship crude oil from Alaska overseas because we are not geared up to refine that product in the western U.S.. Our limitations on supplies of oil and gasoline are limited as much by refinery capacity as they are by crude oil supplies. Will developing the reserves in places like ANWR really help our domestic situation? Refinery capacity is a major capital and environmental investment for the oil industry. The oil companies are not going to make those types of capital investments without a significant long-term crude oil supply such as those developed overseas or projected from an ANWR. Do we really want to take the environmental risks of opening up ANWR to oil and gas exploration? I've worked in the industry for 20 years and I don't believe it is a worthwhile risk when there may be other alternatives. So what are the other alternatives?

I believe that one alternative is ethanol and bio-diesel fuels. I believe that the U.S. needs to make a major energy policy shift away from foreign oil and put significant pressure and emphasis on utilizing renewable resources such as corn and soybeans. U.S. farmers are the most efficient in the world and year after year supply exceeds demand and prices stay pathetically low. The agriculture sector comes to the government year after year

complaining about low prices that they have created by over-producing. There are two ways to improve prices for farm products – cut supply or increase demand. We have historically tried to find ways to entice farmers to cut. We pay them to set aside land in CRP programs. We spend billions of dollars on price supports and guarantees. Our government buys grain at elevated prices to further continue to support prices in a market that is glutted with product. While we have spent some time and effort to create “value added” markets for our products, we have just scratched the surface. We need a major policy shift in the agriculture department to focus those billions of dollars paid for “not growing” and “price supporting” to developing major markets for the products that we grow. It is time for the energy department and the agriculture department to join together and solve two crisis with one solution.

Here is that solution:

The energy department needs to establish a new policy that sets a target for significantly reducing our dependence on foreign oil in the next five years to say 50%. By the end of ten years that dependence needs to drop to 40% and so on. There needs to be significant pressure put on the oil industry to shift their emphasis to providing production and refining capacity to renewable resources. Mom and pop corporations and coops are building small ethanol and bio-diesel plants in the corn-belt. These facilities make only a small dent in the needs of our country. It is time that our government stepped forward with a challenge to the oil industry to essentially burn up all of the surplus corn and soybeans that our country produces. Building large ethanol and bio-diesel plants across the corn-belt will stimulate the economy, provide jobs in an area that is losing farms and farm jobs and provide a market at home for our own products. If we make this a significant part of our energy and farm policies, we can shift most of the billions of dollars that we spend on farm programs for corn and soybeans to providing incentives for ethanol and bio-diesel investment. I firmly believe that if the oil companies put their vast resources into this effort, they can build and operate ethanol and bio-diesel plants more efficiently and effectively than any other sector of our country. Their vast refining knowledge and expertise could be brought to bear on an industry that needs that help.

I have talked with managers with my former company of Chevron and at this time they do not see ethanol and bio-diesel as a significant part of their portfolio. I have talked with employees of Royal Dutch Shell Oil Company and they are slowly embarking on a “renewable resources” strategy for their company. It is time to give these major players some incentive to get into the ballgame now! The oil and gas industry needs to continue to be a significant part of our energy policy. It just needs to become a smaller and smaller part that doesn't put all of our eggs in a shaky Middle East basket. There are numerous advantages to the type of policy shift that I have outlined above and some of them are listed below:

Advantages:

Utilizes more environmentally friendly fuels
Utilizes renewable resources
Increases refining capacity and improves distribution of refined products
Reduces dependence on foreign oil
Reduces the need for a significant military presence to protect foreign oil fields
Creates jobs in the U.S.
Improves our balance of trade
Provides more independence for the U.S.
Delays or prevents oil and gas exploration in environmentally sensitive areas
Saves the taxpayer billions of dollars a year in farm program payments/supports
Unites the country around common goals (conservation should be another goal)
Provides for some bipartisan support
Diversifies our U.S. portfolio
It's the right and patriotic thing to do

I realize that there are some obstacles to overcome to make this happen and I would love to help in any way that I can. Thank you for your time and consideration.

Sincerely,



Wayne K. Larsen

(b) (6)

cc: Vice-President Cheney
Secretary Veneman
Senator Daschle

Secretary Abraham
Senator Johnson
Representative Thune

2001-008226 3/27/01 10:09

008226

21 March 2001

Edward Paul Petcavage

b6

Secretary Spencer Abraham
James Forrestal Bldg.
1000 Independence Ave., SW
Washington, DC 20585

Dear Mr. Abraham:

I understand the need for an energy plan that addresses the needs of all Americans. I urge you to come up with a balanced policy that gives equal weight between the use of fossil fuels (coal, oil, natural gas) and alternative sources of energy.

The urgent, immediate needs of the nation can be addressed with seeking greater efficiency standards, especially in automobiles. My state is getting heavily into research and development of fuel cells. I plan to purchase a hybrid car, or other high mileage vehicle, by 2003. As a landscape architect I know the techniques in reducing residential, etc. energy needs with intelligent landscape improvements. If there was a tax advantage, I would add solar panels on the roof of my house quite quickly.

We eventually must face the facts that clean burning fuels are in our future. The gasoline combustion engine is terribly inefficient and will be soon be replaced by innovative technological inventions. I am against short-term solutions like drilling for oil in natural treasures just so that we can have a couple years worth of power starting ten years from now. We need a little better thinking than that. Energy conservation will reap benefits short and long term. That is worth a try...alot better than putting all our eggs in one basket.

Growing up in coal country (Scranton, PA), I learned that residential cooking and heating with anthracite was replaced, in the economic marketplace, by other more efficient (and cleaner) energy fuels. And the air even got cleaner and easier to breathe.

Please come up with a energy policy that encourages the full range of possible energy sources...not just...fossil fuels take it or leave it.

Sincerely,

Edward Paul Petcavage

29651

Sec. Abraham

3-19-01

Environ

008827

- 1) Why Not more emphasis on wind, solar, hydro powers ??? provide funds for research to ↑
- 2) Why is money taken from those areas make those subjects economical
- 3) Why only Gas, Oil, Coal sources for energy being emphasized?? natural.
- 4) need to work with sources listed in item one above to reduce dependency on foreign oil & natural gas
- 5) Why is BP allowed to sell oil from Alaska to other countries??
- 6) national cap on energy is necessary

J. Spinkman

b6

March 20, 2001

Christie Whitman, Secretary
U. S. Environmental Protection Agency
1200 Pennsylvania Avenue
Washington, DC 20460

Raymond J. Miller

b6

✓ Spencer Abraham, Secretary
U. S. Department of Energy
1000 Independence Avenue, SW
Washington, DC 20585

Subject: Energy and Environment can be a win-win situation with directed Federal Government plan and action.

Dear Secretaries:

OPEC is beginning to realize the extent of their economic power by controlling oil production. The U. S. (and the rest of the world) can do little but pay the price.

President Bush recants on his promise to reduce carbon dioxide levels.

California is struggling to meet its electrical needs, and with rolling black-outs predicted for summer.

Natural gas customers are faced with heating bills three times the normal rate.

With a concerted energy policy, the U.S need never have been in this situation. The whole American economy is closely tied to an ample supply of "cheap" energy. Our future as a nation depends on an uninterrupted supply of energy. Energy is every bit as important to our country as food. Indeed, energy is to industry and our well being as food is for our personal survival

The answer is there and available to us, but we have not had a directed national energy policy to achieve the desired result.

This is not a philosophical problem. It can be reduced to a simple mathematical equation with the need (or use) on one side, and the available resources to meet the need on the other side. We have the data to attack the problem in a logical manner, yet we are not doing it. The solution to our national energy problem is not based on faith or hope, or emotions, but on pure logic and common sense.

We know what our energy needs are today, and we can pretty well predict them into the future. There is little need for me to comment on this side of the equation other than to say that we all can do a better job of energy conservation. With a very conscientious effort we may effect a 10 percent savings. Outdoor, night-time lighting is one area where we could cut back on our energy usage by a considerable amount.

My comments will deal with the energy resources to meet our needs. These are limited and specific. They include natural gas, oil, coal and nuclear energy.

Yes, environmentalists talk about wind power, water power, solar energy, ethanol, methanol, fuel cells and the hydrogen economy. None of these hold any hope of supplying any more than a small fraction of the power we need to keep our economy humming. And electricity is not a primary power source, since energy must be expended to generate electricity. Electricity is a secondary, generated source of power.

Thus we are left with coal, oil, natural gas and nuclear energy to supply our energy needs.

By the way, Energy is what we are talking about. Energy is the ability to do work, and is generally in the form of heat. Power is the time rate of energy expenditure or production. Thus, electrical power is measured in watts or kilowatts or megawatts, or gigawatts, whereas electrical energy is measured in watt-hours, KWH, MWH and GWH. Heat energy is measured in therms, or kilo therms or mega therms, whereas heat power is measured in therms per hour, or kilo therms per hour, etc.

Of the energy sources I cited, all except nuclear energy produce massive amounts of carbon dioxide since this is the normal and expected result of burning a carbon based fuel. Thus, the burning of coal, gas and oil all produce carbon dioxide.

To get to the point more quickly. A sensible national energy policy should be based on using each fuel to its best advantage while minimizing the amount of carbon based fuel burned to limit to a practical limit the generation of carbon dioxide.

We must face up to the fact that nuclear energy is the cleanest energy source we have to use. It produces no exhaust gases; it is plentiful and renewable. Yes, there are risks involved, but they are all well understood, and as a technically oriented nation, we have the ability to solve all of these problems, and minimize the risks. In fact, we have employed nuclear energy for over 50 years in the generation of electrical power. But we have raised so many fears and restrictions that we are "afraid" to proceed with new nuclear based power plants.

Nuclear power must be divided into two categories, namely controlled fission and controlled fusion. Controlled nuclear fusion is looked upon as our ultimate energy solution. Yet, after 50 years of research, we have made only small gains toward achieving usable controlled nuclear fusion energy sources. It is not an option as an energy source into the foreseeable future.

Nuclear fission reactors are currently providing about 17% of the electrical power in the world. France generates about 35% of its electrical power via nuclear energy. The United States generates only about 15% of its electrical power via nuclear power plants.

The Super Carrier, Ronald Reagan, was recently christened by Mrs. Reagan. As with the other 8 super carriers, it will be powered by a nuclear fission reactor. All of our modern submarines are also powered by nuclear fission reactors.

I propose that we begin immediately to reinvent our National energy policy, and use the fuels available to us to best advantage.

This means:

1. Boldly striding forward to build new nuclear based electrical generating plants.
2. Restricting the use of oil and its derivatives to transportation.
3. Restricting natural gas usage to home and industrial heating and processes.
4. Utilizing coal fired plants for electrical power generation in favorable applications.

With the successful implementation of this program, we will significantly reduce the amount of carbon dioxide produced to meet President Bush's commitment to the world environment. We will cut back on our use of oil and natural gas to reduce the demand, and bring the supply-demand equation into balance. We will continue to use our greatest native resource of coal in a conscientious manner.

With respect to nuclear fission reactors, I think they have been treated as bastard children. Each one is different; each one is of custom design and construction. To move ahead with expanded use of nuclear based power generation, we must follow every other successful product, and dating back to Henry Ford. We must standardize designs based on fifty years of experience. I think we should decide on the most appropriate size, and manufacture many on them for installation in many locations throughout the country. The nuclear plant of today may be capable of generating a gigawatt of power. I think this is too much power concentrated in a single location.

I went on line and tried to discover the size or rating of the nuclear power plant on the Ronald Reagan. I could not find it, but this model of reactor could be the basis for implementing my suggested plan of many smaller, and standardized, nuclear generating plants in many locations. Arbitrarily, I would put an upper limit of 100 megawatts on the standard nuclear power generating plant.

To implement my suggested program, three other problems areas must be attacked.

1. Convincing the public that nuclear power plants can be designed to be safe.
2. Eliminating unnecessary approvals, paperwork, and construction requirements that have made the building of new nuclear power plants almost impossible to achieve.
3. Dictating a final permanent resting place for spent nuclear fuel rods. This is another area that has been treated like a bastard child in the past. Even over a particular state's objection, a safe central permanent depository must be dictated and implemented.

A serendipitous benefit of implementing my suggested plan is that it will put the United States in the forefront of nuclear based electrical generating plants – which is where we should have been all along, and will give us a highly viable product to sell to many other nations, and including the third world where there will be an explosive demand for more electrical generating capacity to meet their growing needs without relying on uncertain oil supplies.

Ms. Whitman; Mr. Abraham, please take time to evaluate my proposal. Our nation needs such a plan to remain strong and foremost within the world of nations.

Sincerely,

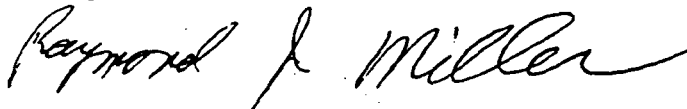

Raymond J. Miller

b6

20 March 2001

Honorable Spencer Abraham
U. S. Department of Energy
1000 Independence Ave, SW
Washington, DC 20585

Dear Secretary Abraham:

I am writing this letter to strongly urge the Bush Administration to support revival of the nuclear option for electrical power generation in this country. It is time the shackles of the last eight years be thrown off this safe, efficient technology, and we move forward.

I realize the task is formidable as you will be assailed by an army of anti-nukes, other assorted pseudo-environmentalists, and an uninformed public. (The very mention of restarting one of the Tennessee Valley Authority's nuclear units was met with shrill opposition by the anti-nukes.) The "greens" must be met with determination and perseverance, and the American people must be educated about nuclear power. We should borrow from the example the French have used to successfully gain acceptance of nuclear power plants: promotion of benefits and mandating power plant management and operators reside close to the facility.

To close the nuclear cycle, we must make the national waste repository operational as soon as possible and restart spent fuel recycling. Once again, I realize these efforts will not be without a struggle, but I am firmly convinced we must try.

It is outrageous that we can build a state-of-the-art, light-water reactor in North Korea and a central waste repository in Russia but not here!

Additionally, I fully support environmentally safe drilling for oil in Alaska (and anywhere else, for that matter), clean-burning coal technology, and a halt to attempts to dismantle our hydroelectric facilities.

I would appreciate your comments on the above suggestions and what the Bush Administration intends to do at the Federal level to return sanity to energy policy.

Yours truly,

Walter L. Adams, Jr.

Walter L. Adams, Jr.

Federal arsenic levels allow cancer, study says

By Seth Rosenstein
Knight Ridder Newspapers

WASHINGTON — Two days after the Bush administration junked a Clinton administration effort to reduce the amount of arsenic in drinking water, a study released yesterday reported that the permissible levels of the toxic chemical are enough to cause cancer.

The study also revealed for the first time how arsenic can start a chain reaction in living cells that ends in cancer.

Christie Whitman, chief of the Environmental Protection Agency, said Tuesday that former President Clinton's proposal to limit arsenic in drinking water to 10 parts per billion was too expensive and "the scientific indicators are unclear."

Whitman's action sent arsenic standards back to the previous level of 50 parts per billion, although she said she would review them and revise them if necessary.

The new study in the March issue of the peer-reviewed journal *Environmental Health Perspectives*, which is published by the government's National Institute of Environmental Health Sciences, is based on exposing rats to arsenic levels equivalent to 25 to 50 parts per billion.

Based on this work, one of the

researchers, Dartmouth University toxicologist Joshua Hamilton, said: "There is sufficient evidence that 50 parts per billion is not protective. I think 10 is a reasonable place to go."

EPA spokeswoman Robin Woods said her agency welcomed the new study and would consider it in developing a new standard for arsenic in drinking water.

The study, by Hamilton and three other professors at the Dartmouth Medical School in Hanover, N.H., explains how arsenic disables one of the body's key cancer-fighting agents. While it has long been linked to cancer, arsenic's role in causing the disease had never been understood, Hamilton said.

Arsenic alone doesn't cause cancer, he explained. Rather, it acts as a kind of vitamin that "enhances the ability of other things to cause cancer."

The Dartmouth researchers studied what arsenic does to a human steroid called glucocorticoid, which fights cancer by binding with genes and telling them what chemicals to produce.

The researchers found that exposure to arsenic allows glucocorticoid to go through its normal binding process, but then mutes its messages so that none of them gets through to the genes. As a result, the genes do nothing to fight cancer.



Columbus Dispatch
3/23/01

3/23/01

2001-008275 3/27 P 3:46

John Castle

(b)(6)

March 23, 2001

Secretary, Spencer Abraham
United States Department of Energy
Washington, D.C. 20585-0121

Dear Mr. Secretary:

I would be most grateful if you would please supply me with the following information:

1. The national energy policy plans (NEPP) for the years of 1993, 95, 97 and 99.
2. The amount of money that [we] our federal government has invested in the form of energy subsidies: the names of the recipients, and the amounts of their subsidies by the year starting with 1970 through the year 2000 as follows:

Oil	Coal	Natural Gas	Nuclear
-----	------	-------------	---------

3. Please furnish the names and locations of the nuclear plants that our federal government has decommissioned to date.
4. Please furnish the federal government's costs of decommissioning these plants by name. Also, the time it takes for decommissioning; the method of storage; the location of storage sites, and the costs of storing the spent fuels (LLW, mixed LLW and HLW).
5. Please furnish the names and the locations of the nuclear plants that are scheduled to be decommissioned in the future, and the projected dates of decommissioning.

I am most grateful for your efforts in fulfilling my request. Thank You.

Respectfully and Sincerely,

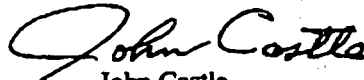

John Castle
Questions?...

bb

Secretary, The

From:
Sent: Friday, March 23, 2001 2:59 PM
To: Secretary, The
Subject: Energy Production

b6

FROM:
NAME:
SUBJECT: Energy Production
ZIP:
CITY:
PARM.1: TO:the.secretary@hq.doe.gov
STATE: Disappointed
TOPIC: The Republican Crisis Mongers
SUBMIT: Send Comments
CONTACT: email
COUNTRY: Thisone

b6

MESSAGE: "Billions have been invested in developing renewable energy and will continue to be invested under the Bush Administration. But renewables have yet to overcome the economic advantages of conventional energy sources". With this statement, the Bush policy is laid bare—the cheapest (i.e., most profitable for the developer) methods will be implemented. With regard to the proposal to open the Arctic National Wildlife Refuge to drilling operations, it means that the "technological advances in exploration"
MAILADDR: 12345

Secretary, The

008419

From:
Sent:
To:

Sunday, March 25, 2001 11:52 AM
Secretary, The

(b)(6)



tmp.htm

Dear Sir,

I would like to see a national energy policy in place. I am not smart enough to know exactly what shape this policy should take. However I am smart enough to know that the rise of natural gas prices was entirely to high and should be investigated.

Thank You
Jay Dodson

Secretary Spencer Abraham
U.S. Department of Energy
1000 Independence Ave., SW
Washington, DC 20585

25 Mar. 2001

Dear Secretary Abraham,

There is a lot of talk in Washington these days about morality. For me, morality boils down to the golden rule, do unto others, as you would have others do unto you. However, this simple dictum is not at all simple to put into practice. It requires constant vigilance over the often less than obvious ramifications of one's actions.

The current energy policy espoused by the Department of Energy and the Bush Administration fails the golden rule test. It implicitly states that unchecked consumption outweighs all other societal values. It specifically ignores the overwhelming evidence (see National Academy of Sciences report on Climate Change) that burning fossil fuels is changing our climate and endangering the health and well being of future generations. How is it that we can afford billions on a missile defense system for theoretical threats, when we cannot afford to invest in energy conservation and renewable, non-polluting energy sources?

We will foul the air with pollutants and destroy the last wild places on earth so we can all drive Ford Excursions with aplomb. U.S. residents will continue to use 459 gallons of gasoline per capita compared with 140 in Germany or 10 in China. When the poor of the world starve from flooding or drought in Bangladesh or sub-Saharan Africa, we will blame it on bad genes and ignore the empirical evidence that our energy policy contributed to their fate.

In the Gospel according to Matthew, Jesus Christ stated "You cannot serve God and mammon". Our worship of rising stock prices, mega Malls, house boats, jet skis and bigger and more absurd homes and vehicles makes it clear that, in the final analysis, we serve mammon and we will destroy everything beautiful in God's creation to feed our habit.

Only when our own way of life here in the U.S. is directly threatened, will we act to try to avert global warming. However, the quantity of CO2 in the atmosphere will not be effected in the short term and our actions will be too late. Our own grandchildren will face a diminished world with more violent weather (the insurance industry has perked up to this inevitability), flooding of coastal cities, drought, increased infectious disease and, possibly, mass extinction. We will not hold a warm place in their hearts.

We need an energy policy that emphasizes conservation and renewable, non-polluting sources. That is our moral obligation to future generations.

Sincerely,



James F. Lombardo, MD

(b)(1)(b)

Secretary, The

From: bb
Sent: Sunday, March 25, 2001 9:51 PM
To: Vice President Dick Cheney
Cc: Secretary, The; President George W. Bush; Strickland, Ted; Senator George Voinovich; Governor Taft; Senator DeWine; NRC-Office of Public Affairs; Rice, Condoleezza; Commerce; Senator Pete Domenici; Committee on Appropriations; Committee on Energy
Subject: ENERGY SOLUTIONS



tmp.htm

3/24/01

Vice President Cheney:

The United States must acquire a long-range national Energy Plan. Incorporated in this plan should be funding for centrifuge research and development (R&D) technology in the United States. Nuclear energy is essential to minimize impacts on local and global environment, provide a reliable and affordable electrical power supply, and place the United States in a situation to play a leadership role in the worldwide nuclear program. Also, the government needs to reclaim ownership of the two uranium enrichment facilities in the U.S. to ensure this industry remains a viable resource in America.

President Bush backed off his campaign promise to regulate carbon dioxide emissions because of the country's energy problems. This proves nuclear energy needs to play a large part of the future Energy Policy to guarantee a high potential for success in meeting the increased electrical needs and to comply with the U.S. Clean Air Act. With Nuclear power the opportunity to improve environmental quality by reducing emissions of air pollutants and greenhouse gases exists, along with providing an energy supply that will take us well into the 21st century.

Nuclear energy efficiency, through new technologies, is at the very heart of the world solution to meet future electrical needs. The U.S. must retain a leadership role in centrifuge R&D to remain as a power in the nuclear worldwide market. To secure the nuclear enrichment cycle in the U.S. decreases foreign dependency and conserves the U.S. energy resources. An Energy Plan that includes nuclear power and funding for uranium enrichment through the advanced Centrifuge Technology prevents America from being held hostage to prices and supplies controlled by foreign suppliers. With the U.S. dependency on oil ever increasing, we will have to export dollars to pay for that oil, deepening our trade deficit.

The U.S. needs to be a major competitor in the uranium enrichment market and the world leaders with the Centrifuge Technology. Also, the government should restructure itself as owner/operator of the two U.S. enrichment facilities, now operated by the U.S. Enrichment Corporation (USEC), to redeem this industries reputation for high product quality and standards that America is known for. I don't think anyone really believes that privatization was the way to go in the uranium enrichment industry. The financial condition of this industry has deteriorated since privatization. The NRC has stated, "USEC will be unable to generate profit from its own SWU production after 2003, when the NRC certificate for Paducah, KY (PGDP) is up for renewal. The only way USEC could be profitable after 2003 would be as a broker of Russian or other materials, and then, only if it can negotiate lower prices from the Russians."

We need a new national energy strategy that recognizes the need for a balanced approach to our energy demands and environmental concerns. Electricity use in the U.S. is expected to increase (27% by 2020) due to technology developments that continue to expand the range of applications for which electricity is the preferred energy source. The U.S. energy policy should encourage nuclear power and the promotion of Centrifuge Technology for uranium enrichment. Centrifuge Technology will guarantee America to be the world's leading supplier of uranium fuel enrichment services and less reliant on the foreign market. Nuclear power we can reduce air pollution, improve efficiency, and promote an industry that reduces the trade deficit experienced in the oil trades.

Teresa K. Mollette; 1

E-mail: r

Voice: 7

bb

29666

Secretary, The

From: [redacted]
Sent: Monday, March 26, 2001 11:08 AM
To: Secretary, The
Subject: Policy

b6

FROM: [redacted]
NAME: Tom Abbott
SUBJECT: Policy
ZIP: [redacted]
CITY: [redacted]
PARM.1: TO:the.secretary@hq.doe.gov
STATE:
TOPIC: Nuclear/bio fuels
SUBMIT: Send Comments
CONTACT: email
COUNTRY: USA

b6

MESSAGE: Dear Secretary Abraham, I have read your recent comments regarding the fact that we will not beg OPEC countries for oil, and that we should continue our exploration efforts. I agree with that assessment. However, I believe that the current energy problems (prices/blackouts, last summers gasoline prices) points out that we still need to have a comprehensive energy policy for this country that includes oil/gas exploration, coal/coal gasification, nuclear energy, and bio fuels energy. Particulary, I
MAILADDR: [redacted]

b6

2001-008309 3/27 P 4:53

008309

Secretary, The

From:
Sent: Monday, March 26, 2001 1:54 PM
To: Secretary, The
Subject: Select

(b)(6)

FROM:
NAME: Ellen Robinson
SUBJECT: Select
ZIP:
CITY: b6
PARM.1: TO:the.secretary@hq.doe.gov
STATE: LA
TOPIC: future energy policy
SUBMIT: Send Comments
CONTACT: email
COUNTRY:

(b)(6)

MESSAGE: Dear Secretary Abraham: I am writing as an individual, not affiliated with any organization, who recognizes the need, which President Bush has expressed, for the United States to develop an energy policy. But I am also concerned we will choose nuclear energy without having the means to rid ourselves of the nuclear waste. So I am writing to ask you to consider other means of developing America's energy independence. Thank you for your time and consideration. Sincerely, Ellen Robinson
MAILADDR: 5000 Leon Dr. #52

Secretary, The

(b)(6)

From: Secretary, The
 Sent: Monday, March 26, 2001 2:18 PM
 To: Secretary, The
 Cc: George W. Bush; Dick Cheney
 Subject: Remarks by U.S. Secretary of Energy Spencer Abraham U.S. Chamber of Commerce. National Energy Summit March 19, 2001

I agree that a balanced energy policy is needed. Why then was your speech 99% weighted toward increasing domestic production of fossil fuels?

Dependence upon fossil fuels (and also nuclear energy) is dependence upon energy sources that

- 1) harm the public health through production of poisonous by-products,
- 2) threaten agriculture and economic stability through alteration of global climate and
- 3) jerk consumers around due to extreme sensitivity to supply manipulation at every stage of production and delivery.

Irregardless of whether these fuels come from foreign or domestic sources, dependence upon them still constitutes harm to us all, even those who temporarily profit from this dependence.

So long as public policy favors increasing fossil fuel production over the sustainable alternatives of:

- A) conservation and energy efficiency;
- B) public transit infrastructure instead of 2 SUV's in every garage;
- C) solar, geothermal and off-the grid alternatives for general heat/water/light;

so long will we remain DEPENDENT upon harmful and wasteful energy practices, and the MYTHS that perpetuate them.

THIS is what people mean when they talk about conspiracies to gouge consumers. The FTC was barking up the wrong tree when it investigated gasoline suppliers. Believe me, the American people know it. Just like we know that the timing of the California blackouts is too coincidental to be true. When the blind man eats wontons, in his stomach he knows how many.

Although the Energy Secretary is not an elected official, he is no less obligated to recommend and execute, to the very best of his ability, policies that will benefit all Americans in this and future generations. To this end, I call upon you to lead the way in

- 1) Promoting energy efficiency and conservation across the board, but especially in the field of transportation;
- 2) Giving strongest support to real development of a diversified suite of clean, alternative energy sources, with the goal being to transfer our dependence AWAY FROM FOSSIL FUELS and over to these as soon as possible;
- 3) Ensuring that those areas of fuel production which are still tied to fossil fuels will be conducted with minimum environmental impact;
- 4) Respect the American people's rightful refusal to have nuclear waste stockpiles and potential Chernobyls -- no nuclear power.

Weekly
Planner

MARCH 2001

FOREIGN POLICY:

19 THREATEN SERBS
TOTAL ANNIHILATION
NUCLEAR POWER Monday

20 ABANDON AFRICA:
TOTALLY: Tuesday

21 GIVE ARABS TO
IRAQ FOR OIL:
SEIZE SAUDI OIL Wednesday

22 PEG OIL AT \$40 PB:
SLOW CONSUMPTION
TO 3M BARRELS A DAY Thursday

23 MAKE OPERATING A
PERSONAL AUTO SO
EXPENSIVE IT CAN'T
BE DONE... Friday

24 RUSSIAN COMMUNISM
WORKS BETTER THAN
DEMOCRACY. LET
THEM RETURN: Saturday

25 SIGNED:
LORD LESLIE SHAFFER
LORD DONALD SHAFFER
PS/HP/POPE Sunday

DONALD SHAFFER

(b)(6)

Weekly
Planner

MARCH 2001

ENERGY POLICY

19

SENIORS ARE STARVING
Monday

20

SENIORS ARE COLD
Tuesday

21

AUTOS ARE TOO EXPENSIVE
TO OPERATE IN FUTURE.
Wednesday

22

NATURAL GAS IS TOO
EXPENSIVE NOW:
Thursday

23

LIVES ARE BEING
LOST BECAUSE OF
ELECTRICITY RATES
Friday

24

THIS IS DEATH IN THE
NATION: MURDER 3.
Saturday

SIGNED

25

LORD LESLIE SHAFER
LORD DONALD SHAFER.
Sunday

©S/WP/POPE OF THE USA

Secretary, The

(b)(6)

From:
Sent: wednesday, March 28, 2001 3:36 PM
To: Secretary, The
Subject: NATIONAL ENERGY POLICY

Dear Secretary Abraham,

Our country can not be held hostage by the Energy Mafia. Please do something NOW, before it is too late. We need a national energy policy that protects old people and poor people from freezing to death and insures a reasonable return on investment to suppliers.

Thanks for your time.

Sincerely,

Tom Quinn

2001-008945 4/2 P 3:57

Wednesday, March 28, 2001

Secretary of Energy: Spencer Abraham
U.S. Department of Energy
1000 Independence Ave., SW
Washington, DC 20585

Dear Secretary Abraham:

I have reviewed several news reports and summaries regarding the Senate Democrats' recently introduced "Comprehensive and Balanced Energy Policy Act of 2001" and "Energy Security Tax and Policy Act of 2001," and I am impressed with what appear to be the core tenets of this bill:

- 1) Elevate our national energy policy to a more responsible level by giving greater precedence to mainstream environmental thinking and policy.
- 2) Expand lower-impact, more environmentally-benign, renewable energy alternatives and the level of R&D critical to their advancement.
- 3) More evenly balance short-term, power-generation solutions that require nonrenewable energy as their primary input with efficiency increases and reductions in per-person demand.
- 4) Institute better regional energy infrastructure coordination and planning.
- 5) Offer the right mix of incentives and mandates that make tenets 1-4 work.

The only things pertinent to this bill that I question, is the meaning of the proposed dam certification streamlining, the area through which the construction of a natural gas pipeline would traverse, and the lack of stronger clean air standards applicable to the power generation industry. I am, after all, not in favor of seeing more dams built. And I do not support building a pipeline that would pass through frontier wilderness tracts.

Outside of those three issues, I believe this legislation would positively impact our economy through its increased emphasis on efficiency and alternative energy generation. Such an emphasis has already proven to spawn creative problem solving at the research level, as well as a host of technical, service, and other related jobs and industries.

That is why I endorse the Senate Democrats' bill. Its progressive nature is more in tune with energy policy recommended by respectable, forward-thinking scientists, business leaders and mainstream environmental groups worldwide.

Sincerely,



Stephen Koermer

address:

(b)(6)

(b)(6)

29673

Wednesday, March 28, 2001

Secretary of Energy Advisory Board
U.S. Department of Energy, AB-1
1000 Independence Ave., SW
Room 8E-044
Washington, D.C. 20585

Dear Secretary of Energy Advisory Board:

I have reviewed several news reports and summaries regarding the Senate Democrats' recently introduced "Comprehensive and Balanced Energy Policy Act of 2001" and "Energy Security Tax and Policy Act of 2001," and I am impressed with what appear to be the core tenets of this bill:

- 1) Elevate our national energy policy to a more responsible level by giving greater precedence to mainstream environmental thinking and policy.
- 2) Expand lower-impact, more environmentally-benign, renewable energy alternatives and the level of R&D critical to their advancement.
- 3) More evenly balance short-term, power-generation solutions that require nonrenewable energy as their primary input with efficiency increases and reductions in per-person demand.
- 4) Institute better regional energy infrastructure coordination and planning.
- 5) Offer the right mix of incentives and mandates that make tenets 1-4 work.

The only things pertinent to this bill that I question, is the meaning of the proposed dam certification streamlining, the area through which the construction of a natural gas pipeline would traverse, and the lack of stronger clean air standards applicable to the power generation industry. I am, after all, not in favor of seeing more dams built. And I do not support building a pipeline that would pass through frontier wilderness tracts.

Outside of those three issues, I believe this legislation would positively impact our economy through its increased emphasis on efficiency and alternative energy generation. Such an emphasis has already proven to spawn creative problem solving at the research level, as well as a host of technical, service, and other related jobs and industries.

That is why I endorse the Senate Democrats' bill. Its progressive nature is more in tune with energy policy recommended by respectable, forward-thinking scientists, business leaders and mainstream environmental groups worldwide.

Sincerely,



Stephen Koermer

(b)(6)

2001-009535 4/6 4:04

Secretary, The

From: (b)(6)
Sent: Friday, April 06, 2001 1:06 PM
To: Secretary, The
Subject: Policy

FROM: (b)(6)
NAME: Mark Frankis
SUBJECT: Policy
ZIP: bb
CITY: r
PARM.1: TO:the.secretary@hq.doe.gov
STATE: ca
TOPIC: policy idea
SUBMIT: Send Comments
CONTACT: email
COUNTRY: usa

MESSAGE: Here's an idea I had concerning energy policy: Offer a large bonus to the first state that can produce 5,000+? megawats of power by either solar or wind etc. (i.e. new facilities etc.) The bonus would have to be large enough to be interesting: \$10 or \$20 billion?. The funds would be paid after 90-180 days of operation at the target megawats etc. The state that won would decide how to spend the money or rebate the money... Some of the effects that I can think of are: - It's a sold acti
MAILADDR: ? bb

Nathan M. Wiser

(b)(6)

March 29, 2001

George W. Bush
President of the United States
1600 Pennsylvania Avenue
Washington, D.C. 20500

Re: Your Proposed Energy Policy

Dear President Bush:

Each day, I read with reservation, the proposals coming from your administration relating to our nation's energy policy. Each day I assume that it cannot get more alarming, yet it does. Each passing day I have nearly vowed to stop reading the papers because I grow weary of being upset at what I read. Today, I have decided to communicate my thoughts to you as a means to take a more active part in shaping the energy policy emerging from the Oval Office, and that of Vice-President Dick Cheney. I am also sharing these thoughts with your Energy and Interior Secretaries, Spencer Abraham and Gale Norton.

I understand that both you and Mr. Cheney have strong connections to the oil and gas industry. I also understand that there is an energy crisis in California resulting in widespread "rolling" blackouts and that this is likely to continue into the near future. Yet, these two facts should not unduly influence your decisions regarding the future status of this country's National Monuments and other lands held in public trust. Please do not cite the California energy problem as an excuse to drill for oil and gas on public lands. I know you understand that the problem in California has little to do with current oil and gas supply, and much more to do with the problematic legislation created in that State whereby energy suppliers cannot pass enough of their costs on to consumers to stay solvent. There are other problems in California such as power plants having been shut down for various regulatory and safety reasons that are unrelated to oil and gas supply.

Simply proceeding with new drilling today would, at best, result in increased domestic oil and gas supplies some 10-20 years later, not by the summer of 2001, when Californians and others will engage in peak energy usage. This is because drilling, if followed by oil and gas discoveries, is only the first in many steps needed to actually supply the petroleum resource. Oil and gas field development, production facilities, gathering systems, and transmission pipelines must then be constructed and implemented. Power plants may need to be built or retrofitted to handle the new supply. These steps will surely not be finalized for many years.

A typical oil or gas well takes about one month to drill, complete and test and there are currently about 1200 drilling rigs nationally. This means that the rate of oil and gas drilling would not exceed approximately 14,400 new wells per year. The fact that many of these rigs are not available to drill new wells because they are in use reworking existing wells or drilling other

types of wells such as saltwater disposal or enhanced recovery injection wells only serves to reduce this number. In addition, an average new oil well may produce 30 to 50 barrels of oil per day. Each year then, the maximum daily incremental increase in oil production would not exceed 500,000 barrels (considering 300 to 330 operational days per year). This same number of extra daily barrels of oil could be saved if the nation's automobiles simply increased their gasoline efficiency by 3 miles per gallon (5 mpg is equivalent to 1 million barrels per day). Further, compare this number to the 25 million barrels of oil produced each day by the OPEC nations.

Right now other measures and incentives could be implemented and offered to reduce our current national energy consumption. If every person in this county were to implement some sort of energy conservation measure such as turning down thermostats, exchanging high-wattage light bulbs for lower wattage bulbs, eliminating the number of automobile trips taken, using more public transportation and reusing and recycling more, significant energy savings would result. This alone may be sufficient to stabilize our dependence on foreign oil, a goal you have set out. We must not go on using energy at outlandish rates, justifying our need to rape and pillage the few remaining unspoiled parts of this country in the name of ever increasing energy needs! There is no other nation on this planet that uses as much energy on a per capita basis as the United States.

There will come a day when history books will contain a chapter called the "Age of Petroleum" and will refer back to a period when humans first discovered petroleum in Pennsylvania, built a world-wide infrastructure to exploit petroleum, and finally exhausted the resources around the world. I wonder what words will also be contained on the final page in that chapter. Perhaps there will be additional wars such as the 1991 Persian Gulf War, or collapse of nations. However the last days of the "Age of Petroleum" will be described in history books, there will almost certainly be a discussion of how the world transitioned from petroleum to the next energy source. Please consider how your name and current role might display on that page.

Government has an important role with energy companies. Government can encourage energy companies such as Exxon-Mobil, BP Amoco, Royal Dutch Shell, Chevron-Texaco, Conoco, and others to begin moving to corner the market on the next sources of cleaner energy, such as hydrogen, geothermal, wind- and solar-based platforms. Government can offer economic incentives to these companies to accomplish this. Economics after all is the strongest motivating force that exists. Incentives can include cost or regulatory barriers to continued oil and gas development as well as economic or regulatory stimulus to develop alternative energy sources. Would it not be a sad day if Exxon-Mobil, the world's largest petroleum company, finds itself laying off the majority of its personnel because it failed to anticipate the future, and can no longer out-compete what was formerly a small company developing an alternative energy such as wind power and which has now grown to be the giant energy company Exxon-Mobil once was?

Japan is spending more than twice the amount of money the U.S. spends on research for the use of hydrogen as an energy source. Do we want to play catch up with Japan on such a vital technology?

Despite the fact that your proposed energy policy contains some minor support of alternative energy, it relies far too heavily on more and more oil and gas. I have seen many oil and gas fields, and frankly I don't care to see one in any National Monument, National Park, or

designated wilderness area. The scars left are far too ugly, and the ground water and surface water pollution potential due to benzene, toluene, ethylbenzene and xylenes is too high, and the greenhouse gases emitted into the air contribute too much to global warming.

If oil and gas production in this country must increase, then direct additional effort to extract the already-proven reserves, amounting to several hundred billion barrels, where existing infrastructure can readily produce the resource. Increased secondary and tertiary recovery of oil would become economically viable if tax incentives of \$2-3 per barrel were made available to the oil producers. This alone could result in production of over 1,000,000 additional barrels per day to domestic oil production. Further, an increase in your spending budget to federal agencies such as the Environmental Protection Agency and Department of Interior would help to provide the staff needed to process permits needed by the oil producers to implement this simpler solution. These are actions you could take which would result in a more rapid oil and gas production increase, since much less additional oil and gas production infrastructure would be needed.

Please reconsider your position. If you insist on cramming your energy policy down this country's collective windpipe, we may choke. Don't forget that you won the 2000 presidential election by the narrowest of margins under highly questionable circumstances, and there are many people waiting for a chance to reverse the control of the U.S. Congress in 2002 and future elections.

Sincerely yours,

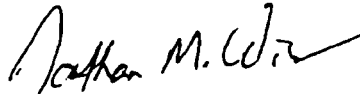

Nathan M. Wiser, a regular voter

cc: Spencer Abraham, Secretary
U.S. Department of Energy
1000 Independence Ave., SW
Washington, DC 20585

Gale Norton, Secretary
U.S. Department of Interior
1849 C. Street N.W.
Washington, DC 20240

MARCH 29

b6

2001-008873 4/2 11:43

The Honorable Spencer Abraham
Secretary of Energy
1000 Independence Ave., SW
Washington, DC 20585

Dear Sir:

I am enclosing a letter written to our President concerning the current debate over energy and arsenic in our water. I do so, believing that these issues are all or in part a concern of yours and the department which you direct.

Thank you for your thoughtful consideration in these extremely important matters.

Sincerely yours,

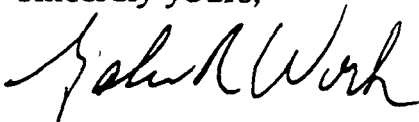

Galen R. Work

29679

b6

March 29, 2001

President George W. Bush
The White House
Washington, DC 20500

Dear Mr. President:

As a life long registered Republican I want to register my opposition to the recent proposals to explore the pristine regions of our Alaskan wilderness for oil.

I also was appalled by the dismissal of a proposal to reduce arsenic levels in drinking water.

The enclosed article and cartoon from the March 23 issue of *The Columbus Dispatch* address the issues of oil exploration and arsenic in drinking water. We cannot continue to allow short term profiteering under whatever guise to determine policies which will inevitably, sooner or later, have to be reversed for the long-term health and well being of people and their environment.

“An ounce of prevention is far cheaper than that future pound of cure.”

Sincerely yours,

Galen R. Work

CC: Departments of Energy, Health & Human Services, and Interior

29680

R. BRUCE MCBRATNEY, JR.
JULIA A. MCBRATNEY

2001-009302 4/5 3:41

April 3, 2001

President George W. Bush
The White House
1600 Pennsylvania Avenue NW
Washington, D.C. 20500

Dear Mr. President:

Recent statements by you and members of your administration have confirmed some of the misgivings we had about you during the campaign. We urge you to reconsider your position on two related issues.

Energy policy

We are more than casually interested in this issue. I worked for one of the major oil companies for over 5 years, with many of their most senior executives. I continue to consult with two of the global majors. More than 15% of our personal portfolio is in oil company stocks, and I suspect will be for some time to come. That said, here are our concerns:

Please stop taking the American public for fools. The electricity shortage in California is primarily the result of misguided regulatory policy and poor planning, NOT a shortage of domestic oil and gas. Exploring and drilling in ANWR, then building a gas pipeline to the lower 48 likely has a 7-10 year lead time before the first mcf shows up at a gas turbine that can deliver electricity to anyone in California. So stop intimating that if we could just get drilling more on the North Slope, then Silicon Valley wouldn't be left in the dark this summer. Or maybe there is a way ... if you know of one, we'd like to know it, and you owe such an explanation to the American public.

Currently proven US oil and gas reserves, and even those likely to be proved over the next 5 years will never make the US less dependent on foreign oil in any way that would allow us to really move the world price of oil. So please stop holding out domestic exploration as a panacea.

However, increased domestic exploration could forestall rises in prices for a few more years. Such a forestallment would have two harmful effects on the *long run* success of the United States.

- 1) If energy prices do not rise there will continue to be little effect on consumer behavior that makes us per capita users of energy at twice the rate of Europeans (who appear to enjoy a similar, if not better, average quality of life). More SUV's, more suburban sprawl and resulting traffic gridlock that have the US commuting times at a world high. And a delay of the necessary free market incentives for alternative energy sources to attract investment and demand that they need to become significant players.
- 2) Government investment in alternative fuels should be compared with the potential significant give-away of two resources that would appear to be "free" and should not be: cheap access to Federal lands, and the continued profligate "use" of an atmosphere that cannot take much more CO2 without generating potentially devastating economic dislocation for farmers, communities that will have to spend to alter their water supply as weather patterns shift, and eventually water inundating our the most populated parts of our country (East and West coasts). These outcomes will be very expensive to tax payers and the economy, albeit probably not during your administration or before your re-election campaign.

(b) (6)

29681

April 3, 2001

Use this opportunity to provide real vision, one in which hydrocarbons play a significantly *lesser* role within ten years, and American technology and markets enable the unprecedented growth of alternative, non-CO2 producing energy sources. Oil companies will adapt, don't worry about them. We'll still need plastics, and we'll likely not be driving hydrocarbon-free cars for a long time to come (hybrid engines, maybe). Visit the Shell or BP web-sites. They are preparing for this transition, shouldn't we?

Kyoto

Obviously, we see the first issue related to this second one. We think your position on this treaty is an embarrassment to us as Americans who do business in Europe and elsewhere.

The logic of backing out of this agreement suggests that our economy can only remain competitive if we are allowed to compete on the same environmentally destructive basis as third world countries such as China, India, and Brazil. Our first world competitors are willing to take the economic risks you see in the treaty, possibly because they have confidence that they can compete on the basis of their ingenuity and drive. I'd rather take my chances on that approach than watch fertile Midwest farmland turn into desert before my grandchildren marry and have children.

The US produces 25% of the greenhouse gases. China is distant second to us, producing half as much. We are in a position to make the biggest impact on this problem. We can take a leadership position, or we can stick our isolationist heads in the sand and pretend that we don't share one atmosphere. I hope you will see this as an opportunity for a legacy of world leadership, and not the insular, short-sighted protectionism your current view appears to be.

We look forward to hearing your views on these issues. More importantly, we hope you will reconsider the views you and your administration have recently articulated. We have copied our senators and our congressperson on this letter so that they are also aware of our concerns and will hopefully represent our views to your administration. We are also providing copies to your appointed leaders at the Department of Energy and the EPA. Because of the impending visits from our European allies on Monday, we are sending this message via e-mail to you to ensure its speedy delivery. A hard copy will follow.

Our best wishes to you in leading this great country.

Sincerely,

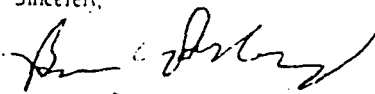
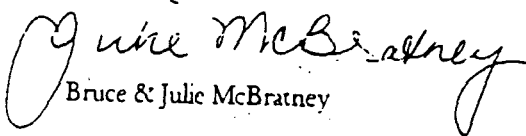

Bruce & Julie McBratney

cc: Senator Richard Durbin
Senator Peter Fitzgerald
Congresswoman Jan Schakowsky
Secretary Spencer Abraham
Administrator Christine Todd Whitman

29682

2001-009510 4/6 P 3:33

009510

Owen Jones

(b)(6)

Spencer Abraham, Secretary
U.S. Department of Energy
1000 Independence Avenue, SW
Washington, DC 20585
25 March 2001

Dear Secretary Abraham,

I have ten years of business experience in petroleum technology development. I also have some political experience in the conservative wing of the GOP. I am concerned that an energy policy that stresses the development of ANWR, as important as that is, will be incomplete at best, and detract from the only policy that can and should supply America with limitless petroleum supplies and freedom from the OPEC Cartel. If, indeed, that is the policy this government really wants.

The only answer can come from Alberta, Canada where reserves are estimated at 1 ½ to 2 ½ TRILLION barrels. That's 100 to 200 TIMES the ANWR reserves. It is 5 to 10 TIMES the reserves in Saudi Arabia. This petroleum reserve is coming on line slowly, and only due to advances in technology in recent years. Even so, with current technology, they can only recover about 20% of reserves. My company has developed a sensing device that could increase that recovery rate substantially, which is why I am more familiar with the Alberta reserves than most people who claim to follow the industry closely.

The real problem is that there is no lobbying effort in Washington to encourage more capital investment in Alberta's vast petroleum reserves. There is only one, small, conservative national security think tank in Washington that has made any reference to Alberta as the solution to our dependency on OPEC and on other nations and regions that are either politically volatile or hostile to U.S. interests.

We need to have an energy summit with Canada to explore ways in which capital investment in Alberta can be increased dramatically, whilst cooperating with environmentalist groups and locals who do not want their province to become a suburb of Houston. It is a challenge, but it is the only answer to our dependency problems. By bringing Alberta's reserves to their full potential, we also affect the world price dramatically, by preventing OPEC from using the Cartel to set the price. (Interestingly, OPEC makes no mention of Alberta's vast reserves on their website, which otherwise gives an accurate count of global reserves by nation and region).

29683

The bottom line is that there simply are not sufficient reserves in the U.S., including ANWR, to reduce our increasing dependence on foreign oil—no matter how the numbers are shuffled. What we essentially need is a North American Energy policy that follows the course that has already been charted by NAFTA and by Canadian deregulation of their domestic industry. This is in the best interest of American consumers and taxpayers, and, I dare say, to the GOP and to this administration.

I propose an innovative approach, not unlike that used by the Canadians themselves to promote more capital investment. They have essentially waved their high royalty payments that the companies must pay until they have made a return on their investment. This is not a subsidy. It is an incentive, which involves setting aside a major, government-created obstacle. We can wave or postpone royalty payments in the U.S., in exchange for an agreement to invest more, both in the U.S. and Canada.

The other major problem is the cost vs. price analysis conducted by the petroleum exploration and production companies. They prefer to invest many billions in nations that are politically corrupt and volatile because the cost per barrel for exploration there is less than in Alberta. The U.S. government should not be in the business of guaranteeing a price floor for commodities. In fact, we have been getting rid of those over the last decade. But perhaps the American consumer will be willing to guarantee a price at the pump that is considerably less than the current price, but more than the deflationary prices that afflicted the industry for most of the 80's and 90's. That will induce the petroleum exploration companies to have much more confidence in the North American market.

There is a need for innovative approaches on a scale commensurate with the Manhattan Project, but without any direct cost to the Treasury. A North American Energy Summit would bring all of the players to the table to offer their best thinking on the subject. This summit would, of course, include Mexico. It will also be a big hit for the DOE, which, unfortunately, has a reputation as a stodgy bureaucracy that has done little if anything since its founding to promote sound development strategies.

I realize that you receive much unsolicited advice. But I believe my suggestions are important enough to warrant your personal consideration. I will call to follow up and I hope to be able to speak to you or a member of your policy staff in the near future.

Yours sincerely,

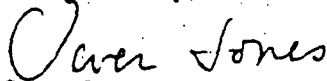
Owen Jones

2001-009616 4/9 4:27

Gabriela Mangini Granados

(b)(6)

(b)(6)

Secretary of Energy Abraham
US Department of Energy
1000 Independence Avenue SW
Washington, D.C. 20585

Dear Secretary Abraham,

This is a short letter stating my concern for our environment and the recent energy policies that are being drafted.

The United States is the country that uses the most energy in the world and the country that wastes the most energy in this world. Wouldn't it make more sense to establish policies of conservation instead of further consumption? Our environment is not getting any cleaner, is not getting any less polluted. We have more cancer, more infertility, numerous birth defects in areas where there are chemical dump sites, etc. I don't need to enumerate all the instances.

You have been appointed to a very powerful and important position in this cabinet. I urge you to stand by the laws that promote conservation and the protection of our environment so that we may have a place to live for our children and the generations to come. Many people would support a more pro-environment stand. **If you helped enact laws of conservation—thermostats a little warmer in summer, a little cooler in winter, speed limits that are enforceable, mandatory recycling, more energy conserving automobiles (less SUV and enormous family trucks), emissions standards that promote cleaner air, the United States will actually have more energy in hand and less money will be spent in the long run.**

Our welfare is directly linked to the environment that we live in. Drilling in the Arctic Circle won't solve our mentality of waste that we have in this country. Please use your position of power to help the citizens of the US be stewards of our environment, please help the leaders to teach us to have a healthy earth so that we might enjoy the benefits of fresh air, flora and fauna and water. **Please listen to the smaller voices that are eager to follow the lead of the White House in conservation, recycling and example.**

Sincerely,

Gabriela Mangini Granados
Gabriela Mangini Granados

b6

29685

IDEAS

□ Energy

CONTINUED FROM 1D

• This volume would not all emerge in one burst, but over a period of decades. Lots of oil fields in lots of places are needed for the huge volumes of petroleum that America guzzles. To argue that Arctic refuge oil does not matter because it cannot single-handedly solve petroleum supply needs is like saying there's no point in a farmer planting a field because no single farm can possibly feed the nation.

The real flaw in the argument for drilling the refuge is not that 3.2 billion barrels does not matter but that from an energy-policy standpoint, oil conservation measures can produce a better effect faster. Improving the gasoline mileage of the nation's new vehicles by just three miles per gallon would displace more petroleum than the Arctic National Wildlife Refuge is expected to produce.

According to calculations by the Natural Resources Defense Council, a more ambitious but technologically feasible goal of raising new-vehicle average fuel economy to 39 miles per gallon over the next decade would displace more than 15 times as much petroleum as the refuge is expected to produce.

Although technology exists to improve gasoline mileage without any sacrifice in the way people drive, federal miles-per-gallon standards have not changed in 12 years. Given legal sanction to build oil-wasting sports utility vehicles, automakers have done so. In turn, because SUVs have pushed up U.S. gasoline consumption in the past decade, supply has become tight and pump prices have risen.

If Bush wants a serious, balanced energy policy, he must include production incentives and new mandates for conservation, by far the most important of which, from the standpoint of oil equilibrium, is higher miles-per-gallon standards for SUVs and light trucks. Yet Bush has said nothing about raising miles per gallon.

The first major energy bill introduced this year in Congress, by Sen. Frank Murkowski of Alaska — the Murkowski bill is seen as a trial balloon for an expected White House bill — contains numerous provisions for more drilling in the Arctic National Wildlife Refuge and elsewhere, but says not a word about raising miles-per-gallon standards. New Energy Secretary Spencer Abraham recently gave his first major policy statement — a speech titled "A National Report on America's Energy Crisis." The speech was full of calls for more oil production, yet Abraham never so much as mentioned fuel economy or vehicle miles per gallon.

A balanced national energy strategy might combine higher miles-per-gallon levels for vehicles and other conservation measures with exploratory drilling in the Arctic National Wildlife Refuge, as environmental concerns regarding the latter seem exaggerated. Oil production has been ongoing in Alaska's North Slope for almost one-quarter century, with the Exxon Valdez oil spill the only significant blunder, and Prince William Sound has mostly recovered. North Slope oil production has caused small-scale ecological problems that have not made the newspapers, including many

minor crude spills and an estimated 70 waste sites that have some form of contamination, such as spilled diesel fuel. Although troubling, these errors are manageable and nothing like the broad-ranging ecological harm originally forecast for Prudhoe Bay and its pipeline. A 2000 study by the Trustees for Alaska, which opposes Arctic National Wildlife Refuge production, elaborately documented many secondary problems caused by North Slope oil production but no fundamental ecological harm.

This has not prevented opponents from forecasting that refuge oil production will cause "devastating environmental destruction," in the words of the Natural Resources Defense Council. Yet, any oil prospecting in the refuge will be done with improved technology that causes less environmental disruption than what was first used at Prudhoe Bay, including much more accurate drilling seismology, less-leaky systems and the relatively new adaptation of ice roads. Rather than paving lanes between drill sites, oil companies have begun to make roads from ice; when the drillers leave, the ice melts and the "footprint" of exploration is gone. The fact that broad-ranging environmental harm has not happened during North Slope drilling does not, of course, guarantee that it won't happen in the Arctic National Wildlife Refuge. But the risk seems comparatively small.

If there is going to be a balanced U.S. energy policy, both sides must make concessions. Conservationists must acknowledge that America needs continuing oil production, and perhaps drill rigs in the Arctic refuge must be part of that. Any environmentalist who drives a car and fulminates against oil drilling is talking out of both sides of his or her mouth. Put another way: Only greens who don't own cars and refuse to ride in cars, taxis, buses, trains or airplanes have a genuine right to denounce oil drilling.

In turn, business lobbies and Republicans in Congress and the White House must acknowledge that conservation is just as important as production. Trying to produce enough oil to fill the tanks of ever-more SUVs will be a losing battle if the SUVs remain guzzlers. It is unfair — and bad policy — to ask those who love the wilderness to give up some of their claims to the beauty of the Arctic National Wildlife Refuge in order that those who drive wasteful, antisocial large vehicles won't have to give up anything at all.

Finally, voters must accept that this isn't just an abstract fight between the zealots of the left and right. Gasoline supplies are sensitive because Americans are buying huge vehicles with huge engines and driving them more and more. You can't insist on the freedom to buy a wasteful vehicle, then complain about gasoline prices when the laws of supply and demand respond to the consequences of your own choice.

America's energy problems are caused by Americans — and won't be solved until Americans face that fact.

■ Easterbrook, senior editor for the New Republic and BeliefNet.com, is a visiting fellow in economics at the Brookings Institution.

Old-economy middlemen are stepping up defense of their turf.

Car dealers and others want states to curb e-commerce with laws to regulate Web sales of autos, contact lenses, tobacco, mortgages, etc.

State lawmakers will lend sympathetic ears to powerful retailers that have home district connections, despite consumer groups' complaints that restrictions on e-commerce limit options and jack up retail prices.

Nuclear power is on the comeback trail, spurred by growing demand for electricity and rising concern about global warming from fossil fuels. U.S. electricity requirements will grow up to 2.5% annually through '20.

Utilities are pushing to renew operating licenses for nuke plants, a reversal of the nuclear facility decommissioning trend of recent years. Meanwhile, plants will be consolidated into the hands of fewer operators, which promises to improve their management and boost their efficiency.

Smaller, cheaper, safer nuclear reactors also on the horizon... "pebble bed" reactors, which utilities aim to start building by '10 or so. Look for nukes to supply 30% of U.S. electricity by '20...20% now.

A "multipollutant" approach to cleaning the air is all the rage in Washington these days. Means regulating nitrous and sulfur oxides, mercury and carbon dioxide (CO₂) emissions under one rule. Cuts pollution and could save power companies money through regulatory streamlining.

Power firms and green groups both back it...unlikely bedfellows.

Bush and a key senator too: Environment Com. Chair Smith, R-N.H.

But House will stop it in its tracks. Key members are dead set against opening the door to CO₂ regulation, say it would be too difficult.

Automakers won't fight higher fuel efficiency standards this year, giving up a 10-year battle to keep corporate average fuel economy as-is. With Senate support for CAFE freeze eroding, they'd rather aim elsewhere:

They'll seek a tax credit for energy-smart cars...\$2000 for buyers of gas/electric hybrids, other efficient vehicles. Bush will OK the idea as part of his upcoming energy plan, and it's already popular in Congress. Bet on a trade-off...higher CAFE standards for more clean-car tax credits.

Truckers will benefit from new materials that will replace steel in the making of bumpers, other truck parts. Lighter and less susceptible to corrosion, they'll help truckers save on fuel and maintenance costs. Carbon- and glass-fiber composites will also allow for new truck designs.

New drugs to fight heart disease will get FDA's OK next few years.

Viprinex...clot-busting drug derived from venom of a pit viper... will speed the recovery of stroke victims. Made by Abbott Laboratories.

Natrecor...a genetically engineered hormone to alleviate fatigue, shortness of breath in people with congestive heart failure. From Scios.

Ranolazine...to ease chronic angina. Coming from CV Therapeutics. The drug reduces the heart's demand for oxygen by altering its metabolism.

And CETi-1...a vaccine that blocks formation of bad cholesterol and boosts levels of good cholesterol. From Avant Immunotherapeutics.

Flap over genetically modified grain will hurt U.S. corn exports.

Overseas buyers are turning up their noses amid reports that some corn is mixed with StarLink variety...OK'd for animal, not human consumption.

U.S. says just a tiny amount is affected, but foreigners remain leery. Regulators will crack down to prevent future accidental mixing of seed.

Meanwhile, Ag Dep't will bail out farmers by buying up tainted seed corn.

KIP LINGER LETTER
1000 1/15
3/9/2001

b6



OFFICE OF THE VICE PRESIDENT
WASHINGTON

April 13, 2001

Dear Mr. Marsico:

On behalf of the Vice President, I thank you for taking the time to forward to us your comments and suggestions regarding a national energy policy. We sincerely appreciate hearing from you.

In January of this year President Bush established the National Energy Policy Development Group, which is chaired by Vice President Cheney. Included in this group are the Secretaries of Agriculture, Commerce, Energy, Interior, Transportation, Treasury, and the Administrator of the Environmental Protection Agency, as well as the Director of the Federal Emergency Management Agency. The State Department has also been participating.

It is our mission to develop a national energy policy to help the private sector, and as necessary and appropriate, Federal, State and local governments, to promote dependable, affordable and environmentally sound production and distribution of energy. In developing our final report, we will be sure to keep in mind your thoughts and suggestions.

Again, thank you for taking the time to contact Vice President Cheney. We have a significant undertaking ahead of us, but I am confident we will be able to develop a national energy policy that meets the energy needs of our country in a dependable, affordable and environmentally sound manner.

Sincerely,

Andrew D. Lundquist
Executive Director,
National Energy Policy Development Group

Mr. Ronald Marsico

B6

b6

Ronald Marsico

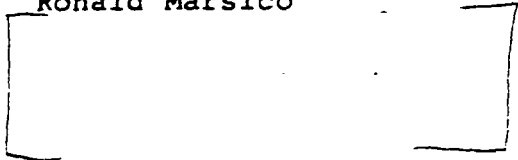

April 20, 2001

Mr. Andrew D. Lundquist
Executive Director
National Energy Policy Development Group
Office Of The Vice President
Washington, D.C., 20501

Subject: U.S. Patent No. 4,686,325 -- CATENARY SAG ADJUSTMENT
USING ADDED WEIGHTS.

Dear Mr. Lundquist:

Thank you very much for your recent reply to my initiative to the Vice President. I certainly agree that resolution of the nation's energy problems is a significant undertaking and I commend the Administration for taking swift action to resolve these multi-faceted problems.

My 36 years of experince in the electrical transmission line business (including management, engineering, research, and purchasing) suggest to me that innovative solutions that safely "squeeze" additional power-transfer capabilities out of certain existing transmission lines could be an important part of the national energy policy.

Prudently applied novel ideas to up-grade some applicable existing transmission lines could be cost-effective, timely, and endorsed by the environmental community. In addition to the subject Patent, I have some other ideas that might be helpful in this regard.

While I retired about 4-1/2 years ago, I still maintain a strong interest and understanding about transmission line issues. You may find that my long experience could be useful to your Team as you address these very important challenges.

Therefore, I would welcome a dialogue (via phone or meeting) with appropriate people on your Team to explore these ideas.

I will be at my winter home in Florida until May 5. After that, I can be contacted at my permanent address which is:

Sincerely,
Ronald Marsico
Ronald Marsico

29689

We the People

The United States of America

The Commissioner of Patents and Trademarks

Has received an application for a patent for a new and useful invention. The title and description of the invention are enclosed. The requirements of law have been complied with, and it has been determined that a patent on the invention shall be granted under the law.

Therefore, this

United States Patent

Grants to the person or persons having title to this patent the right to exclude others from making, using or selling the invention throughout the United States of America for the term of seventeen years from the date of this patent, subject to the payment of maintenance fees as provided by law.

Donald D. Higgins

Commissioner of Patents and Trademarks

Melvin Gary Attest



United States Patent [19]

[11] Patent Number: 4,686,325

Marsico et al.

[45] Date of Patent: Aug. 11, 1987

[54] CATENARY SAG ADJUSTMENT USING ADDED WEIGHTS

842181 6/1981 U.S.S.R. _____ 52/40

[76] Inventors: Ronald Marsico, 935 Loch Ness Ave., Worthington, Ohio 43085; Bruce Freimark, 814 Francis Ave., Bexley, Ohio 43209

OTHER PUBLICATIONS

Acton, Win. "Computer Aids Weight-On-Line Solutions," *Transmission and Distribution*, Nov. 1978, pp. 40-42.

Primary Examiner—Laramie E. Askin

[21] Appl. No.: 864,075

[57] ABSTRACT

[22] Filed: May 16, 1986

Methods to achieve catenary sag and shape adjustments that can reduce sags and increase clearances at certain locations of overhead flexible conductors, cables, strands, or wires to underlying lands, roads, waters, and other objects by permanently adding and attaching essentially concentrated weights or weight of certain magnitudes and positions on the said conductors, cables, strands, or wires.

[51] Int. Cl. _____ H02G 7/00

[52] U.S. Cl. _____ 174/40 R; 174/43

[58] Field of Search _____ 174/40 R, 40 TD, 42, 174/43, 45 R, 45 TD; 52/40

[56] References Cited

FOREIGN PATENT DOCUMENTS

586887 10/1933 Fed. Rep. of Germany — 174/40 R
366708 2/1932 United Kingdom _____ 174/40 R

6 Claims, 9 Drawing Figures

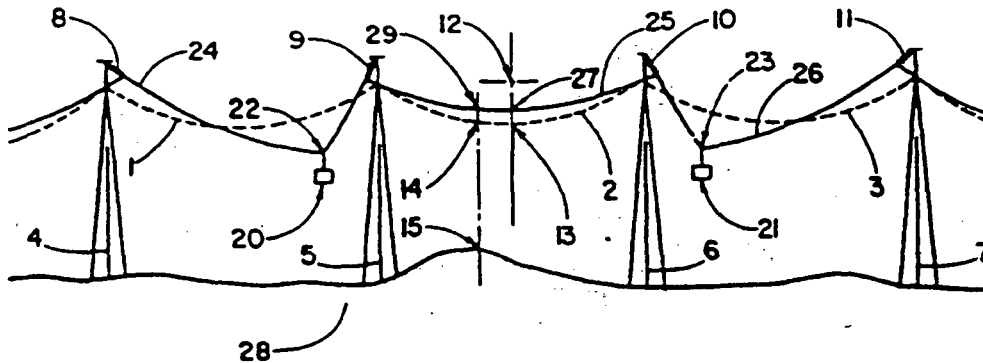

ice fees
of the

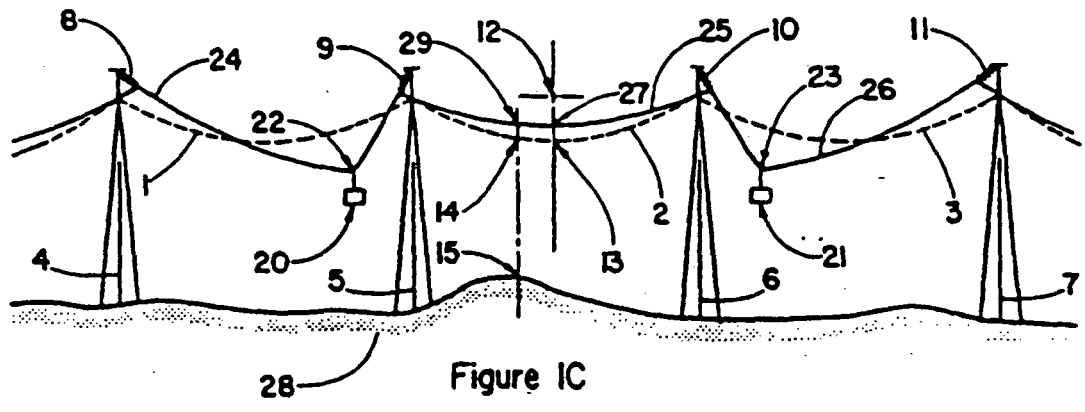
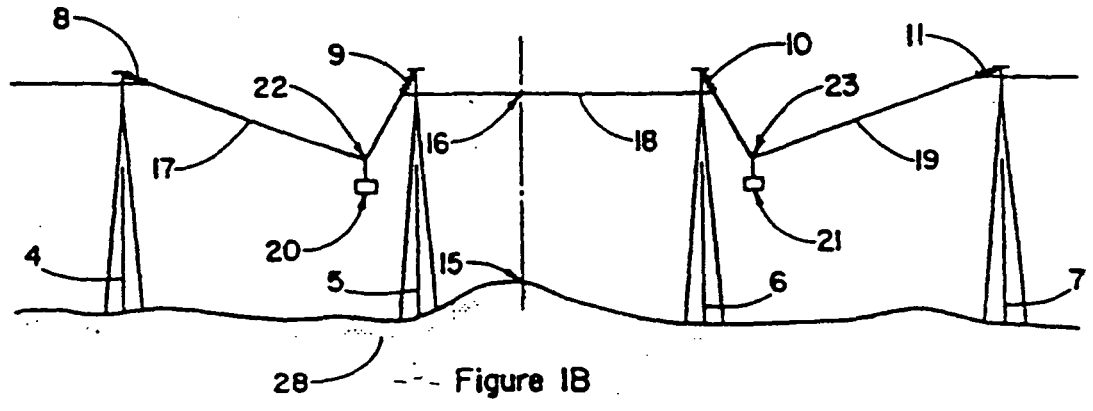
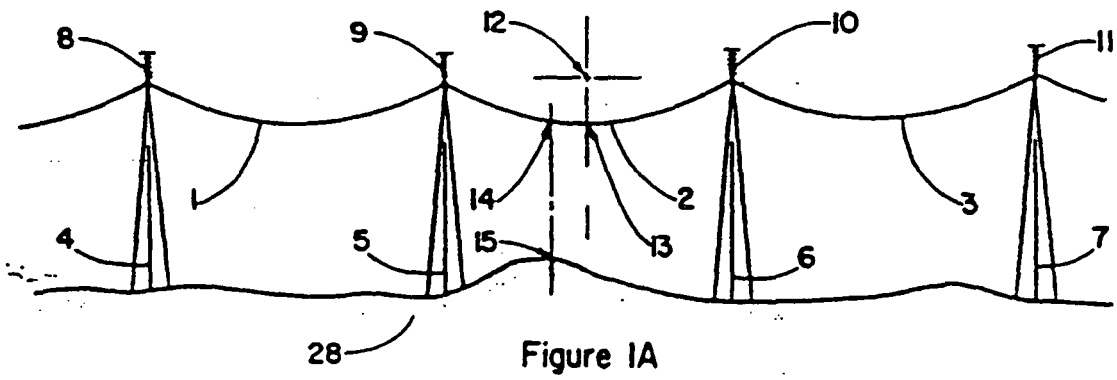

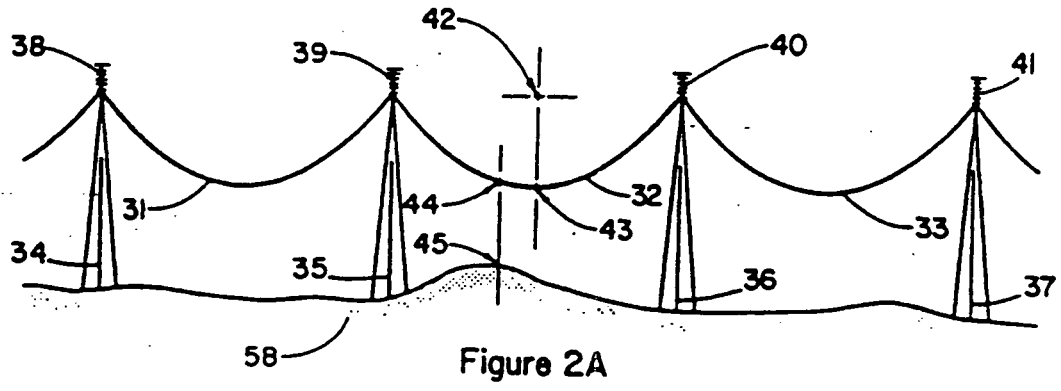

Figure 2A

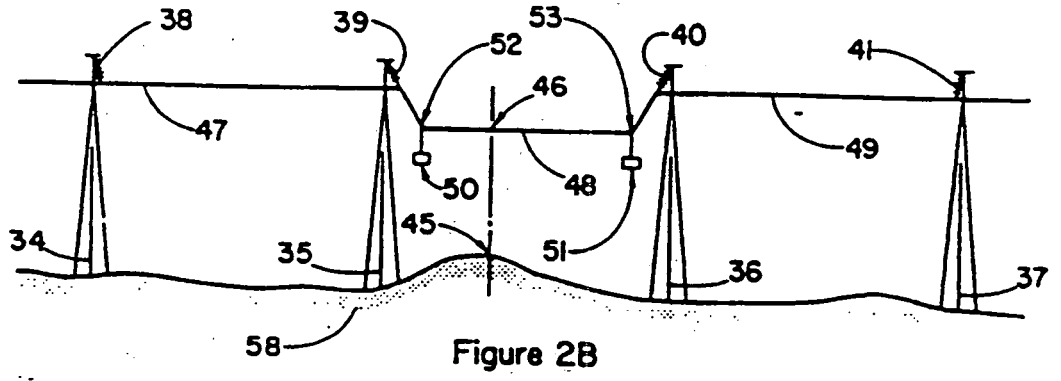

Figure 2B

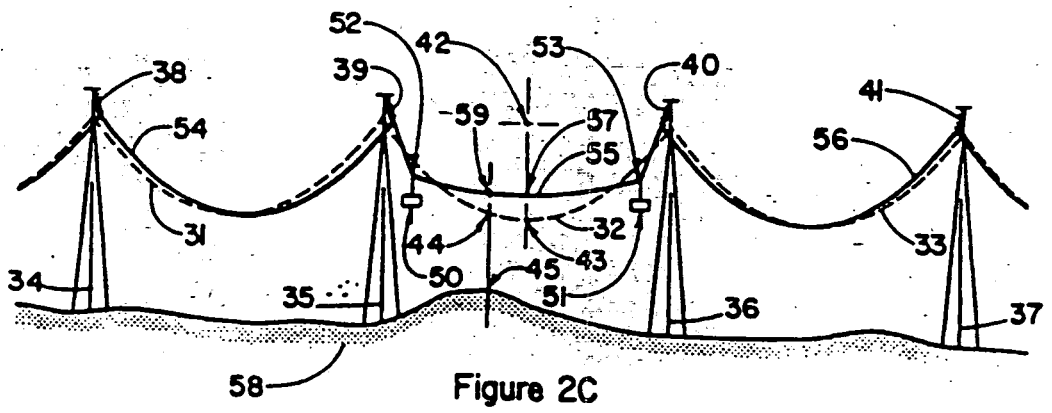

Figure 2C

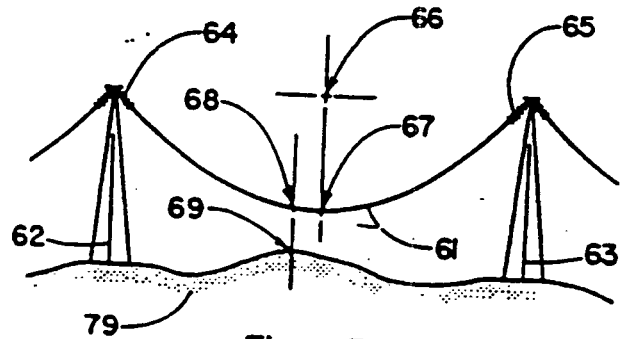

Figure 3A

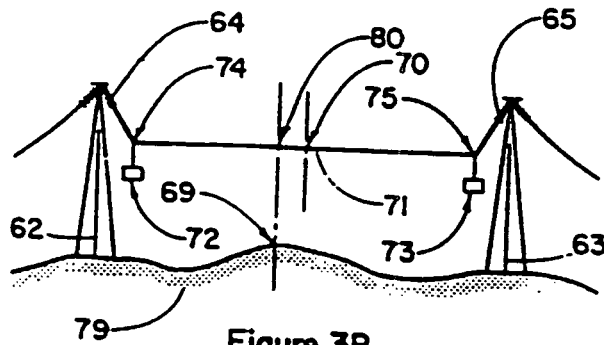

Figure 3B

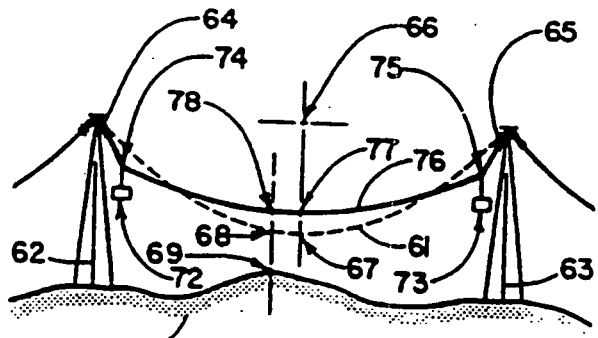

Figure 3C

CATENARY SAG ADJUSTMENT USING ADDED WEIGHTS

FIELD OF THE INVENTION

The invention relates to methods of reducing sags and increasing clearances of flexible overhead conductors, cables, strands, or wires to underlying lands, roads, waters, and other objects at certain locations without raising supporting structures or cutting out a section of the conductors, cables, strands, or wires in order to reduce their sag.

BACKGROUND ART

Occasionally, on existing overhead electrical power lines or other utility lines, it is necessary to obtain additional clearance between energized electrical power lines or other utility lines and underlying lands, roads, waters, and other objects such as farms, pastures, highways, driveways, utility lines, buildings, lakes, and rivers.

While solutions such as raising structures, lowering or rerouting of underlying lines, and installation of additional structures are all accepted practices, it is desirable and useful to have alternate solutions which are less disruptive to existing facilities, quicker to install, reduce outage time, and are more cost effective.

OBJECTS OF THE INVENTION

It is therefore an object of our invention to provide alternate and novel methods of increasing clearances between existing overhead electrical power lines or other utility lines to underlying lands, roads, waters, and other objects by methods which minimize disruption to existing facilities and by utilizing readily available materials.

It is a further object of our invention to provide alternate and novel methods to offset extra conductor, cable, strand, or wire sags on existing overhead electrical power lines that would result when it sometimes is desired to increase the current and power delivery capability of certain lines. As the current in amperes increases on an electrical power line, the temperature of the conductor, cable, strand, or wire also increases with corresponding increases in sags. These increases in sags may be partially or completely offset by the decreases in sag that may be obtained along a few or many miles of electrical power lines by selective and repetitive use of one or more of our catenary sag adjustment methods recited in our claims or as illustrated in FIGS. 1A, 1B, 1C, 2A, 2B, 2C, 3A, 3B, and 3C.

GENERAL DESCRIPTION OF THE INVENTION

Broadly, this invention relates to methods by which a flexible conductor, cable, strand, or wire which normally hangs in the shape of a catenary (which is the mathematical curve that results from the uniform weight per lineal foot of flexible conductor, cable, strand, or wire being supported by adjacent structures) has its sag permanently adjusted such that certain sections of the span between structures are raised while other sections of the span between structures may be lowered.

This catenary sag adjustment is accomplished by the permanent addition and attachment of essentially concentrated weights or weight to the conductors, cables, strands, or wires at various locations in spans adjacent

to or in near proximity to the span desired to be adjusted or within the adjusted span itself.

Our invention, therefore, artificially changes the basic catenary shape such that at certain locations within the span or spans the sag of the conductor, cable, strand, or wire can be decreased (with resulting increased clearance to underlying lands, roads, waters, and other objects) and at other locations within the span or spans (where there may be excessive clearance to underlying lands, roads, waters, and other objects) the sag may be increased.

As used herein, flexible means that the ratio of the diameter of the conductors, cables, strands, or wires divided by their respective lengths is negligibly small.

As used herein, span is the horizontal distance between any two adjacent supporting structures to which are attached overhead electrical power lines or other utility lines.

As used herein, sag is the vertical distance between a straight line drawn between the adjacent conductor, cable, strand, or wire connection points at the insulators and hardware on the adjacent supporting structures and the normal or adjusted catenary curve formed by the said conductor, cable, strand, or wire at a particular location within the span.

In a practical test on an existing electrical power line, we have found that by utilizing the method illustrated in FIGS. 1A, 1B, and 1C where the average span between supporting structures was approximately 1,265 feet and the bare weight per foot of the conductor was 1.434 pounds per lineal foot with a diameter of 1.345 inches, the addition of approximately 525 pounds of essentially concentrated weights at each of the two locations shown resulted in a calculated approximate 2.5 feet less sag at a location at the middle of the middle span 5-6 at a conductor temperature of 171° F. as compared to the normal bare conductor catenary sag without added weights. The weights were located approximately 128 feet from structures 5 and 6 in FIG. 1C in the spans adjacent to the middle span 5-6 and it was in the middle span between structures 5 and 6 in FIG. 1C where a decrease in sag and a corresponding increase in clearance to underlying land was desired. In the spans 4-5 and 6-7 which contain the approximately 525 pounds each of essentially concentrated weights, there was a calculated increase in conductor sag of approximately 2.0 to 2.5 feet at the middle of the spans, with a corresponding calculated decrease in clearance to underlying ground at 171° F. conductor temperature; however, ground clearance in these spans was sufficient to absorb the calculated increases in conductor sag.

In practice it is expected that the addition of essentially concentrated weights or weight at various locations (which weights or weight are permanently attached on the conductor, cable, strand, or wire at appropriate distances away from the connection points or point of the insulators to the conductor, cable, strand, or wire) can cause catenary sags to change by approximately one to five feet. However, the actual magnitude and direction of sag changes that occur at specific installation locations and in the vicinity of these locations are affected by such things as: amount of added weights or weight and their location in various spans; type of conductor, cable, strand, or wire and its weight per lineal foot, its diameter and installed tension; length of spans; insulator and hardware configuration (suspension or dead-end); temperature; wind; and ice conditions. Since the addition of concentrated weights or weight

increases conductor tensions and increases vertical loads, the effect on the conductor, structures, hardware, and insulator loadings within the installation locations and in the vicinity of the installation locations needs to be considered, as well as possible effects of the added concentrated weights or weight on aeolian vibration and the placement of aeolian vibration dampers. Other factors affecting the magnitude and direction of sag changes caused by the addition of added concentrated weights or weight in the span or spans with added weights or weight and also in the vicinity of these spans are: the magnitude of normal catenary sags, span lengths, vertical span lengths, types of structures, insulator and hardware assembly lengths and their respective weights, 60° F. conductor creep, and high-temperature conductor creep. Furthermore, adding concentrated weights or weight, while raising some sections of the catenary sag, will lower other sections of the catenary sag and these effects need to be taken into account in the various affected spans. Also, the influence of the added concentrated weights or weight on the magnitude and direction of sag changes in other spans in the vicinity of the installation needs to be considered. Sags and clearances and other appropriate calculations and field measurements should be made at various locations in all spans in the vicinity of and including spans to which concentrated weights or weight are added to verify changes (increases and decreases) in sags and clearances that occur under various conductor temperature and weather loading conditions. The effects of added concentrated weights or weight, with respect to increased vertical loads, differential longitudinal loads and increased tensions on the conductors, cables, strands, wires, insulators, hardware, dampers, structures, and foundations, must also be considered, as well as the effects of added concentrated weights or weight on clearances between conductors and ground-wires on the same structure.

BRIEF DESCRIPTION OF THE DRAWINGS

FIG. 1A is a schematic elevational view of a portion of an overhead electrical power line having points indicated thereon used for explaining principles of the invention according to a first embodiment thereof.

FIG. 1B is a view similar to that of FIG. 1A and showing an effect of permanently adding and attaching weights to the power line to adjust sag in accordance with a first embodiment of the invention on an assumed weightless and flexible conductor, cable, strand, or wire.

FIG. 1C is a view similar to FIG. 1B but showing the superimposed effects of the descriptions in FIGS. 1A and 1B and obtained by adding and attaching weights in accordance with the first embodiment of the invention.

FIG. 2A is a schematic elevational view of a portion of an overhead electrical power line having points indicated thereon used for explaining principles of the invention according to a second embodiment thereof.

FIG. 2B is a view similar to that of FIG. 2A and showing an effect of permanently adding and attaching weights to the power line to adjust sag in accordance with a second embodiment of the invention on an assumed weightless and flexible conductor, cable, strand, or wire.

FIG. 2C is a view similar to FIG. 2B but showing the superimposed effects of the descriptions in FIGS. 2A and 2B and obtained by adding and attaching weights in

accordance with the second embodiment of the invention.

FIG. 3A is a schematic elevational view of a dead-ended span of an overhead electrical power line having points indicated thereon used for explaining principles of the invention according to a third embodiment thereof.

FIG. 3B is a view similar to that of FIG. 3A and showing an effect of permanently adding and attaching weights to the power line to adjust sag in accordance with the third embodiment of the invention on an assumed weightless and flexible conductor, cable, strand, or wire.

FIG. 3C is a view similar to FIG. 3B but showing the superimposed effects of the descriptions in FIGS. 3A and 3B and obtained by adding and attaching weights in accordance with the third embodiment of the invention.

DETAILED DESCRIPTION

(The Figures Are Not Drawn To Scale)

FIG. 1A shows the normal flexible conductor, cable, strand, or wire 1, 2, and 3 catenary sags of a series of three spans attached to insulators and hardware 8, 9, 10, and 11 and supported by structures 4, 5, 6 and 7 known as suspension structures in the electric power industry. A catenary is a mathematical curve which describes the shape of a uniformly loaded (along its true length) flexible conductor, cable, strand, or wire supported between two points. Insulators and hardware are indicated at 8, 9, 10, and 11 and are attached to structures 4, 5, 6, and 7 respectively. Note for span 5-6 the sag between point 13 on the catenary and point 12 vertically above and on a straight line between insulator and hardware attachments 9 and 10 and also the minimum clearance between point 14 on the catenary and point 15 vertically below on the underlying land 28. Underlying land 28 is shown shaded.

FIG. 1B shows the effect of permanently adding and attaching essentially concentrated weights 20 and 21 at locations 22 and 23, respectively, in spans 4-5 and 6-7 immediately adjacent to the middle span 5-6, to an assumed weightless and flexible conductor, cable, strand, or wire 17, 18, and 19 which is attached through insulators and hardware 8, 9, 10, and 11 to supporting structures 4, 5, 6, and 7 respectively. The shape of this conductor, cable, strand, or wire is seen to consist of a series of straight lines. Note for span 5-6 the smaller sag in the conductor, cable, strand, or wire 18 and the greater vertical clearance between points 16 and 15 near the mid-portion of the middle span 5-6 and how the suspension insulators and hardware 8, 9, 10, and 11 on adjacent structures move longitudinally along the line towards the spans with the added weights 20 and 21. Underlying land 28 is shown shaded.

In FIG. 1C, the conductor, cable, strand or wire shapes shown in FIGS. 1A and 1B are combined and superimposed resulting in adjusted catenary sags and shapes shown by the solid curved lines 24, 25, and 26 such that certain sections of the various spans move upwards while other sections move downward when compared to the dashed curved lines 1, 2, and 3 representing the normal catenary sags from FIG. 1A. Note for span 5-6 that points 27 and 29 move upward relative to points 13 and 14, respectively, and the vertical clearance between point 29 and point 15 is greater in FIG. 1C than the vertical clearance between point 14 and point 15 in FIG. 1A. Also note that the

5

points 27 and 12 in FIG. 1C is less than the sag between points 13 and 12 in FIG. 1A. It should also be noted that, depending on many factors, it is likely that in FIG. 1C the conductor, cable, strand or wire positions depicted by the solid curved line 24 in span 4-5 and the solid curved line 26 in span 6-7 can sag below the curved dashed lines 1 and 3 respectively; if this occurs there needs to be adequate clearance between lines 24 and 26 and the respective underlying lands, roads, waters, and other objects in respective spans 4-5 and 6-7. Underlying land 28 is shown shaded.

FIG. 2A shows the normal flexible conductor, cable, strand, or wire 31, 32, and 33 catenary sags of a series of three spans attached to insulators and hardware 38, 39, 40, and 41 and supported by structures 34, 35, 36 and 37 known as suspension structures in the electric power industry. A catenary is a mathematical curve which describes the shape of a uniformly loaded (along its true length) flexible conductor, cable, strand, or wire supported between two points. Insulators and hardware are indicated at 38, 39, 40, and 41 and are attached to structures 34, 35, 36, and 37 respectively. Note for span 35-36 the sag between point 43 on the catenary and point 42 vertically above and on a straight line between insulator and hardware attachments 39 and 40 and also the minimum clearance between point 44 on the catenary and point 45 vertically below on the underlying land 58. Underlying land 58 is shown shaded.

FIG. 2B shows the effect of permanently adding and attaching essentially concentrated weights 50 and 51 at locations 52 and 53, respectively, in the middle span 35-36, to an assumed weightless and flexible conductor, cable, strand, or wire 47, 48, and 49 which is attached through insulators and hardware 38, 39, 40, and 41 to supporting structures 34, 35, 36, and 37 respectively. The shape of this conductor, cable, strand, or wire is seen to consist of a series of straight lines. Note how the suspension insulators and hardware 39 and 40 attached to adjacent structures 35 and 36, respectively, move longitudinally along the line and towards the weights 50 and 51 within the middle span 35-36. In this configuration, the longitudinal movement of the suspension insulators and hardware 39 and 40 towards the added weights 50 and 51 tends to partially offset the tendency of the center portion 46 of the span 35-36 to rise. The added weights 50 and 51 need to be of such magnitude and at such positions 52 and 53, respectively, that the net effect on the middle span 35-36 is such that the center portion 46 of the span 35-36 rises above the normal catenary position. Underlying land 58 is shown shaded.

In FIG. 2C, the conductor, cable, strand or wire shapes shown in FIGS. 2A and 2B are combined and superimposed resulting in adjusted catenary sags and shapes shown by the solid curved lines 54, 55, and 56 such that certain sections of the various spans move upwards while other sections move downwards when compared to the dashed curved lines 31, 32, and 33 representing the normal catenary sags from FIG. 2A. Note in span 35-36 that points 57 and 59 move upward relative to points 43 and 44, respectively, and the vertical clearance between point 59 and point 45 is greater in FIG. 2C than the vertical clearance between point 44 and point 45 in FIG. 2A. Also note that the sag between points 57 and 42 in FIG. 2C is less than the sag between points 43 and 42 in FIG. 2A. Underlying land 58 is shown shaded.

6

FIG. 3A shows the normal flexible conductor, cable, strand, or wire 61 catenary sag attached through insulators and hardware 64 and 65 of a dead-ended span between structures 62 and 63. A catenary is a mathematical curve which describes the shape of a uniformly loaded (along its true length) flexible conductor, cable, strand or wire supported between two points. The weight of the dead-ended insulators and hardware 64 and 65 at structures 62 and 63, respectively, attachment points is usually small in comparison to the weight of the overall length of conductor, cable, strand, or wire 61; and the insulators and hardware 64 and 65 weight per lineal foot is assumed to be equal to the weight per lineal foot of the conductor, cable, strand, or wire 61 in the remainder of the span 62-63. Note the sag between point 67 on the catenary and point 66 vertically above on a straight line between insulator and hardware attachment points 64 and 65 at structures 62 and 63, respectively, and also the minimum clearance between point 68 on the catenary and point 69 vertically below on the underlying land 79. Underlying land 79 is shown shaded.

FIG. 3B shows the effect of permanently adding and attaching essentially concentrated weights 72 and 73 at locations 74 and 75, respectively, to an assumed weightless and flexible span of conductor, cable, strand, or wire 71 which is dead-ended through assumed weightless insulators and hardware 64 and 65 to the supporting structures 62 and 63 respectively. Note the smaller sag in the conductor, cable, strand, or wire 71 at point 70 and other locations and the greater vertical clearance between points 69 and 80 near the mid-portion of the span 62-63. The shape of this conductor, cable, strand, or wire is seen to consist of a series of straight lines. Underlying land 79 is shown shaded.

In FIG. 3C, the cable shapes shown in FIGS. 3A and 3B are combined and superimposed resulting in an adjusted catenary sag and shape shown by the solid curved line 76 such that certain sections of the span move upwards while other sections move downwards when compared to the dashed curved line 61 representing the normal catenary sag from FIG. 3A. The weight of the dead-ended insulators and hardware 64 and 65 at structures 62 and 63, respectively, attachment points is usually small in comparison to the weight of the overall length of conductor, cable, strand, or wire 61 or 76; and the insulators and hardware 64 and 65 weight per lineal foot is assumed to be equal to the weight per lineal foot of the remainder of conductor, cable, strand, or wire 61 or 76 in the remainder of the span 62-63. Note that points 77 and 78 move upward relative to points 67 and 68, respectively, and the vertical clearance between points 78 and 69 in FIG. 3C is greater than the vertical clearance between points 68 and 69 in FIG. 3A. Also note that the sag between points 77 and 66 in FIG. 3C is less than the sag between points 67 and 66 in FIG. 3A. Underlying land 79 is shown shaded.

DESCRIPTION OF THE PREFERRED EMBODIMENT

Referring to FIG. 1A, there is illustrated a series of spans of a portion of a typical electrical power line in which conductors, cables, strand, or wires 1, 2, and 3 with normal catenary sags are attached by insulators and hardware 8, 9, 10, and 11 to supporting structures 4, 5, 6, and 7 respectively. Note for span 5-6 the sag between point 13 on the catenary and point 12 vertically above and on a straight line between insulator and hard-

ware attachments 9 and 10 and also the minimum clearance between point 14 on the catenary and point 15 vertically below on the underlying land 28. Underlying land 28 is shown shaded.

As shown in FIG. 1B, there is illustrated a series of spans in which the conductor, cable, strand, or wire 17, 18, and 19 is assumed to be weightless and in spans containing conductor, cable, strand, or wire 17 and 19 are added essentially concentrated weights 20 and 21 at locations 22 and 23 respectively. Added weight 20 causes insulator and hardware strings 8 and 9 to move towards weight 20. Added weight 21 causes insulator and hardware strings 10 and 11 to move towards weight 21. Added weights 20 and 21 also tighten the conductor, cable, strand, or wire 18 thereby decreasing the sag in the middle span defined between structures 5 and 6 thus increasing the clearance between points 16 and 15. Underlying land 28 is shown shaded.

Referring to FIG. 1C, there is illustrated by the solid curved lines 24, 25, and 26 the combined and superimposed effects of conductor, cable, strand, or wire positions shown in FIGS. 1A and 1B resulting in adjusted catenary sags and shapes. In particular, it should be noted that the sag of the conductor, cable, strand, or wire between points 27 and 12 in the center portion of the span defined between structures 5 and 6 in FIG. 1C decreases as compared to the sag between points 13 and 12 in FIG. 1A. As shown in FIG. 1C also resulting is a corresponding increase in clearance between point 29 and point 15 on underlying lands, roads, waters, and other objects as compared to the clearance between point 14 and point 15 in FIG. 1A. The reduction in sag, shown as the vertical distance between points 13 and 27 in FIG. 1C, is the desired result of adding weights 20 and 21 at locations 22 and 23 respectively. In FIG. 1C, as illustrated by the solid curved lines 24, 25, and 26 representing the adjusted catenary shapes and the dashed curved lines 1, 2, and 3 representing the normal catenary shapes from FIG. 1A in spans defined between structures 4-5, 5-6, and 6-7, is the change in shape and location of conductor, cable, strand, or wire caused by the addition of weights 20 and 21 at locations 22 and 23 respectively. It should also be noted that, depending on many factors, it is likely that in FIG. 1C the conductor, cable, strand or wire positions depicted by the solid curved line 24 in span 4-5 and the solid curved line 26 in span 6-7 can sag below the curved dashed lines 1 and 3 respectively; if this occurs there needs to be adequate clearance between lines 24 and 26 and the respective underlying lands, roads, waters, and other objects in respective spans 4-5 and 6-7. Underlying land 28 is shown shaded.

We claim:

1. A method of adjusting normal flexible conductor, cable, strand, or wire catenary sags and shapes comprising the step of permanently adding and attaching essentially concentrated weights or weight of appropriate magnitude and position on conductors, cables, strands, or wires in spans immediately adjacent to a span in which it is desired to reduce sag and thereby increase clearances at certain locations to underlying lands, roads, waters, and other objects.

2. A method of adjusting normal flexible conductor, cable, strand, or wire catenary sags and shapes according to claim 1 wherein said step is selectively and repetitively carried out along a few or many miles of an electrical power line in order to increase the electrical current and power carrying capability of the line while still maintaining satisfactory clearances to underlying lands, roads, waters, and other objects.

3. A method of adjusting normal flexible conductor, cable, strand, or wire catenary sags and shapes comprising the step of permanently adding and attaching essentially concentrated weights or weight of appropriate magnitude and position on conductors, cables, strands, or wires in spans in the near proximity of, but not necessarily adjacent to, a span in which it is desired to reduce sag and thereby increase clearances at certain locations to underlying lands, roads, waters, and other objects.

4. A method of adjusting normal flexible conductor, cable, strand, or wire catenary sags and shapes according to claim 3 wherein said step is selectively and repetitively carried out along a few or many miles of an electrical power line in order to increase the electrical current and power carrying capability of the line while still maintaining satisfactory clearances to underlying lands, roads, waters, and other objects.

5. A method of adjusting normal flexible conductor, cable, strand, or wire catenary sags and shapes comprising the step of permanently adding and attaching essentially concentrated weights or weight of appropriate magnitude and position on conductors, cables, strands, or wires within a span in which it is desired to reduce sag and thereby increase clearances at certain locations to underlying lands, roads, waters, and other objects.

6. A method of adjusting normal flexible conductor, cable, strand, or wire catenary sags and shapes according to claim 5 wherein said step is selectively and repetitively carried out along a few or many miles of an electrical power line in order to increase the electrical current and power carrying capability of the line while still maintaining satisfactory clearances to underlying lands, roads, waters, and other objects.

• • • • •

55

60

65



US005777262A

United States Patent [19]

Nourai et al.

[11] Patent Number: 5,777,262

[45] Date of Patent: Jul. 7, 1998

[54] APPARATUS AND METHOD FOR INCREASING ELECTRICAL CLEARANCES OF ENERGIZED CONDUCTORS

[75] Inventors: Ali Nourai, Dublin; Albert J. F. Kerl, Columbus; Ronald Marzico, Worthington, all of Ohio

[73] Assignee: AEP Energy Services, Inc., Columbus, Ohio

[21] Appl. No.: 687,715

[22] Filed: Jul. 26, 1996

[51] Int. Cl.⁶ H02G 7/00

[52] U.S. Cl. 174/40 R

[58] Field of Search 174/149 R, 146, 174/148, 150, 43, 45 R, 154, 40 R, 144, 145, 160

[56] References Cited

U.S. PATENT DOCUMENTS

3,229,031	1/1966	Owens et al.	1740
3,264,401	8/1966	Lutz	174/148
3,316,342	4/1967	Cofe	174/150
3,482,031	12/1969	Rosenberg	174/148
3,614,292	10/1971	Volker	174/148
3,647,933	3/1972	Okada et al.	174/43
4,523,054	6/1985	Baker et al.	174/45 R

Primary Examiner—Kristine L. Kincaid
Assistant Examiner—Dhiru R. Patel

Attorney, Agent, or Firm—Sand & Sebolt

[57] ABSTRACT

An apparatus and method for increasing electrical clearances on power lines to increase the conductor to structure clearance and insulation length and the conductor clearance to ground and other underlying objects. The apparatus may be applied live-line and can be installed without significantly modifying existing support structure. A suspension insulator string extends vertically from the tower and a yoke plate is connected to the bottom thereof. First and second insulator strings extend outwardly in opposite directions from the yoke plate with a dead end strain clamp attached to an outer end of each insulator string. The dead end strain clamp of each insulator string, dead ends the electrical conductor forming an upgrade loop therebetween. A post insulator is rigidly mounted on the yoke plate and extends from the yoke plate to the conductor upgrade loop intermediate to the outer ends of the first and second insulator strings. The apparatus is installed by either re-using an existing vertical suspension insulator string from the support structure or replacing it with a similar insulator string, and mounting the apparatus of the present invention on this vertical insulator string. The conductor is tightened on one side of the tower and the dead end strain clamp of the first insulator string is clamped to the conductor, and the conductor is then tightened on the other side of the tower and the dead end strain clamp of the second insulator string is clamped to the conductor forming the conductor upgrade loop therebetween.

21 Claims, 3 Drawing Sheets

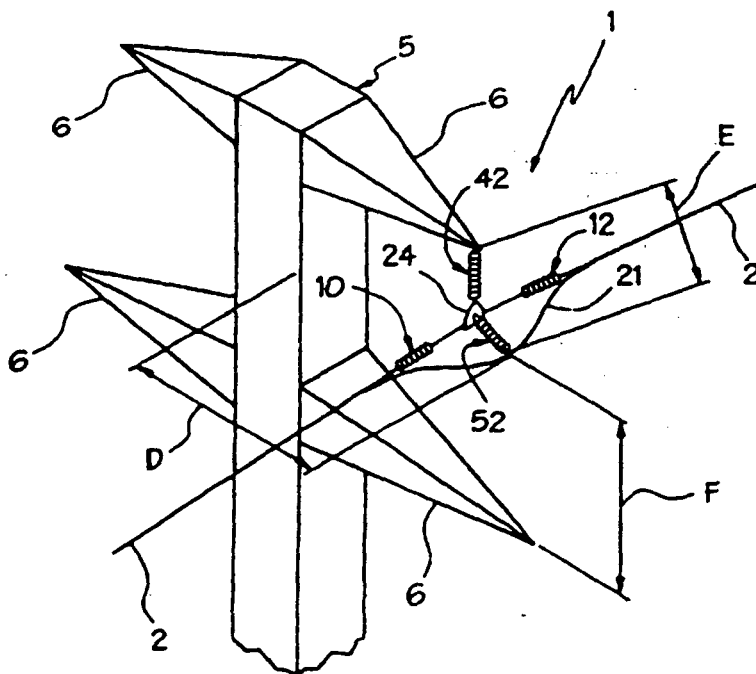

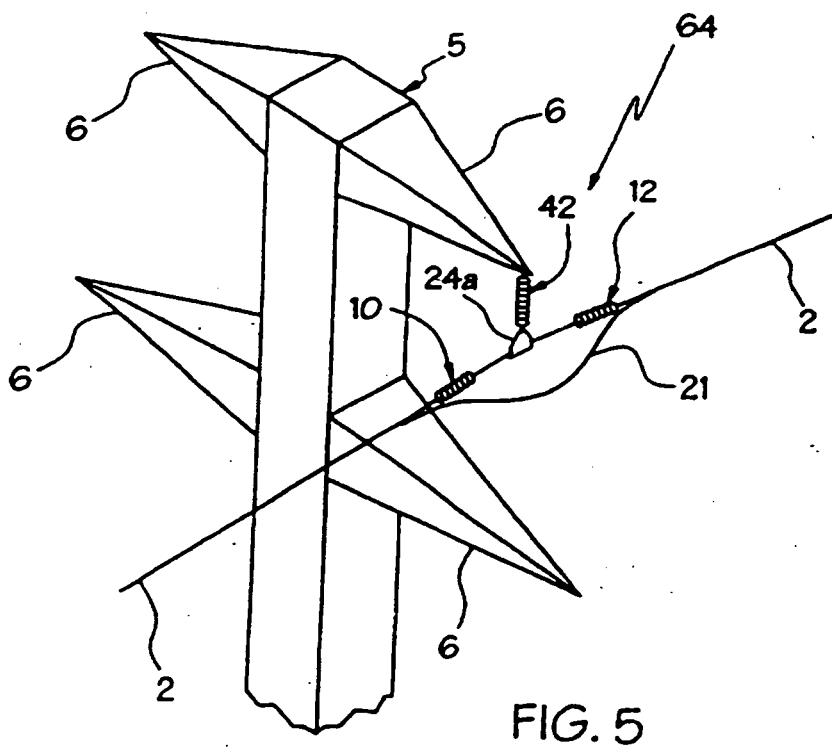
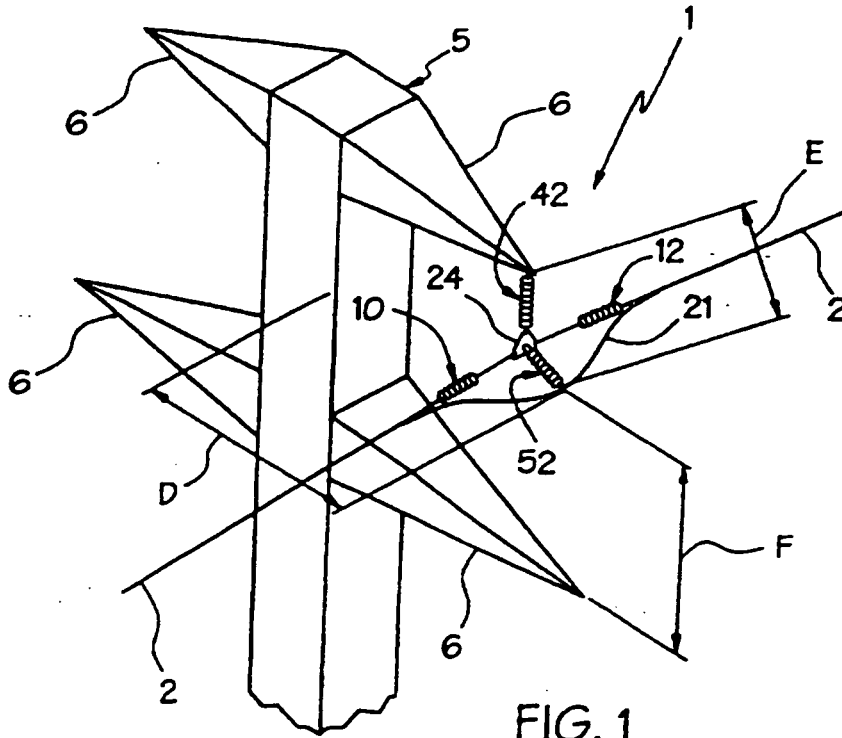

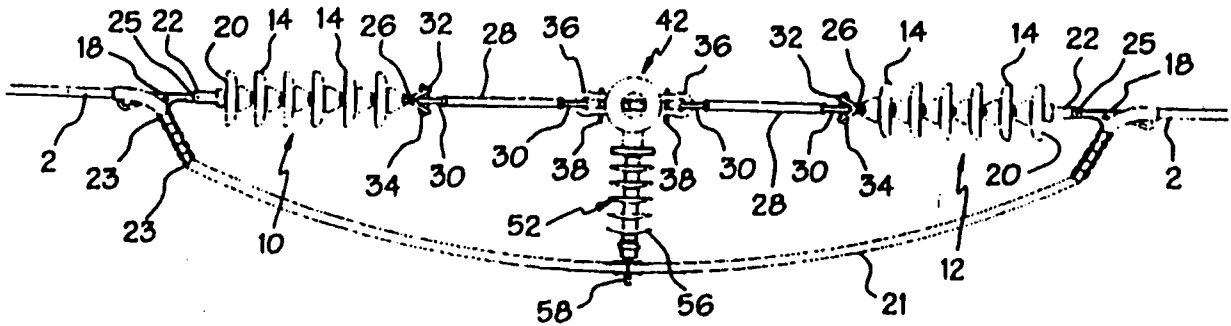

FIG. 2

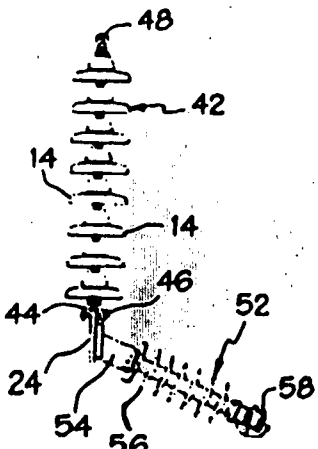

FIG. 4

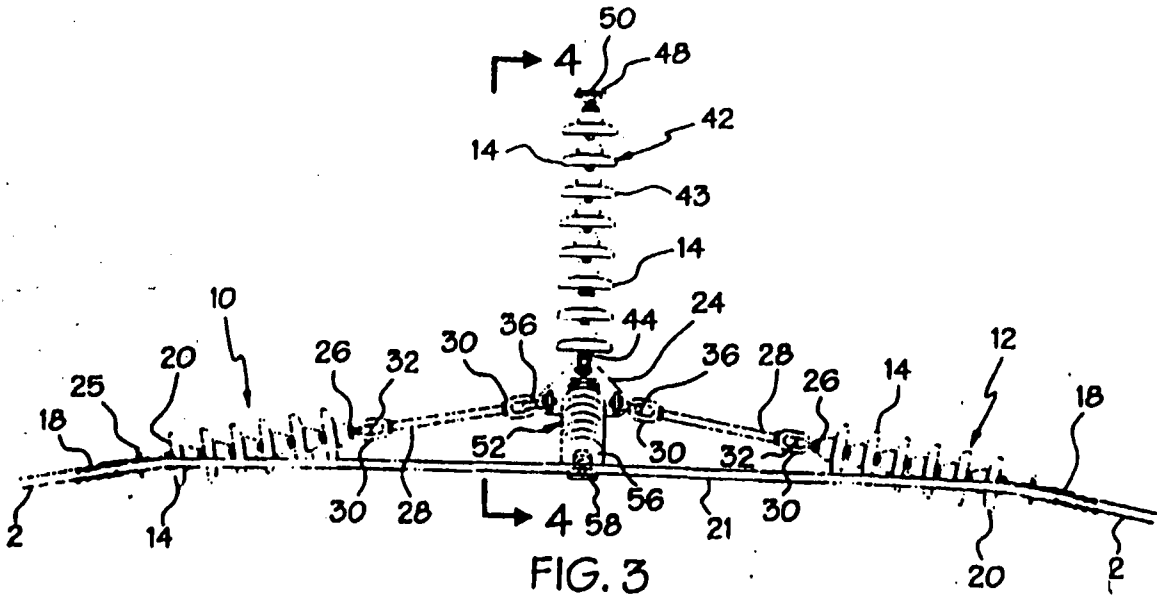

FIG. 3

29701

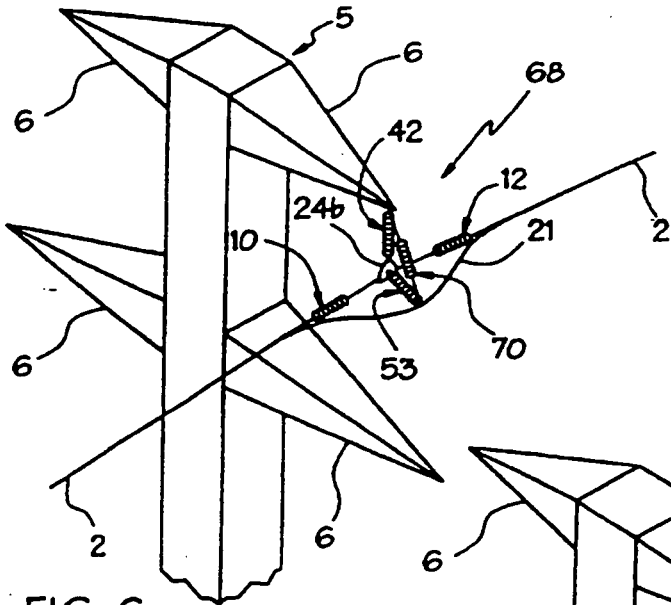

FIG. 6

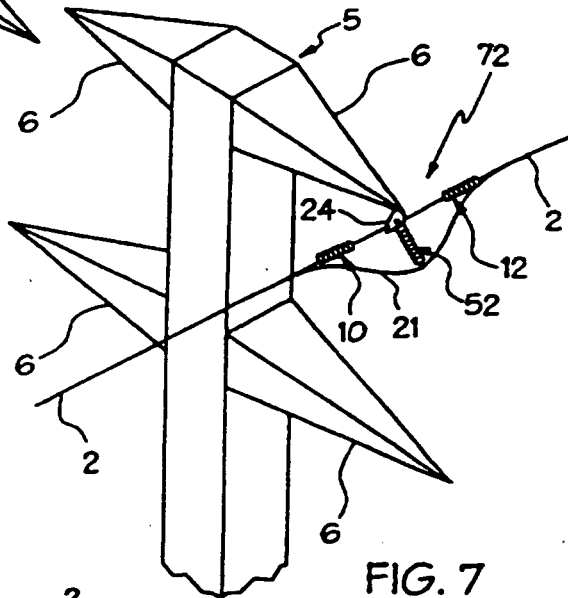

FIG. 7

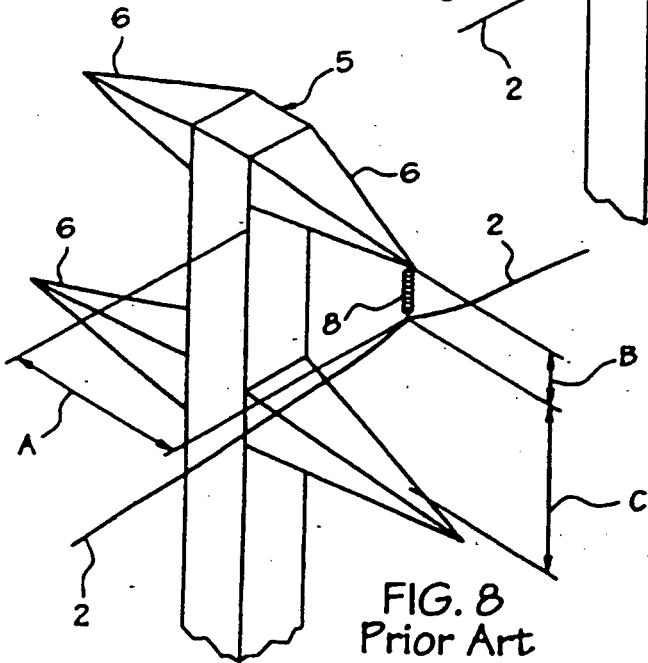

FIG. 8
Prior Art

APPARATUS AND METHOD FOR INCREASING ELECTRICAL CLEARANCES OF ENERGIZED CONDUCTORS

BACKGROUND OF THE INVENTION

1. Technical Field

The invention relates to an apparatus and method for increasing the electrical clearances of energized conductors from their grounded supporting structures and underlying objects. More particularly, the invention relates to such an apparatus and method which includes a plurality of insulators which can be installed without modification to the existing support structures. The apparatus may be installed live line. Even more particularly, the invention relates to an apparatus and method which forms an outwardly extending conductor loop which increases the clearance between the electrical conductor and its support structure, which is able to shorten the catenary length of the conductor between adjacent support structures to increase the clearance between the conductor and the ground and between the conductor and other underlying objects, and which has an increased insulation length.

2. Background Information

Electric companies often wish to upgrade the line voltage to its customers or to certain areas which require additional power. For example, electric companies will upgrade a 138 kV line to 230 kV to strengthen its network for more power flow and energy sales in needed areas. In recent years, electric companies have utilized existing transmission lines and rights of way when upgrading the line voltage to avoid the cost of building additional lines. Utilizing these existing transmission lines poses several technical aspects that must be considered. First, the minimum required clearance between the electrical conductor and the tower or support structure increases as the voltage on the conductor increases. If these minimum clearances are not met, the increased voltage on the conductor will cause arcing between the conductor and the support structure or tower. Second, the minimum required clearance between the conductor and the ground or other underlying objects is greater for lines carrying higher voltage. The catenary sag of the conductor extending between adjacent support structures must be raised approximately 2 to 3 feet when the voltage is upgraded, for example from 138 kV to 230 kV. Third, the support structures suspend the electrical conductors using a vertical string of suspension insulators. The insulation length, determined by the insulation requirement, must be increased when the voltage on the conductor is raised. Also, electric companies often want to improve the electrical performance of lines by increasing the insulation length or conductor clearances.

Conventional apparatuses and methods used to increase the conductor to tower clearance, the conductor to ground clearance and the insulation length often require expensive and time consuming tower modifications. The existing insulators have to be removed from the support structure and the power line must be taken out of service for extended periods of time during the tower modification and installation of the prior art methods. The electric companies must pay work crews to modify the support structures to implement existing methods, they must also pay for any additional equipment needed to modify the support structures, and they lose energy sales during the long period that the power line is taken out of service.

Therefore, the need exists for an apparatus and method for increasing electrical clearances between a conductor and its

support structure which has an increased insulation length, and between the conductor and the ground, which can be mounted on existing electrical towers without significant modification thereto, and which may be installed live-line requiring no service interruption to the electric company's customers. There is no such apparatus and method of which we are aware that accomplishes these results.

SUMMARY OF THE INVENTION

Objectives of the present invention include providing an improved method and apparatus for increasing electrical clearances and insulation-between the conductor and the support structure, and between the conductor and the ground and other underlying objects. This technique requires no significant modifications to existing electrical towers or support structures.

Another objective is to provide such a method and apparatus which may be applied live-line to minimize the interruption of the power flow and service to the electric company's customers.

A further objective is to provide such a method and apparatus which includes first and second insulator strings attached at first ends to the electrical conductor and extending substantially in-line with the conductor, and which form an outwardly extending conductor upgrade loop between the first ends of the insulator strings.

Still another objective is to enable new transmission lines to be constructed with smaller towers than heretofore possible with existing conductor attachment apparatus and methods.

Another objective of the invention is to provide such a method and apparatus which uses various standard hardware items arranged in a novel configuration which can be assembled before being mounted on the support structure.

Another objective of the invention is to provide such a method and apparatus for improving existing line performance against voltage disturbances and insulator contamination.

A further objective of the invention is to provide such a method and apparatus which utilizes existing transmission lines and rights of way for increasing the power transfer through the existing electrical conductors.

These objectives and advantages are obtained by the improved apparatus of the present invention, the general nature of which may be stated as including first and second insulators dead-end clamped at first ends to the electrical conductor and extending substantially in line with said conductor, a section of said conductor forming an outwardly extending upgrade loop between the first ends of said first and second insulators; attachment means for mounting said first and second insulators on the support structure at second ends of the insulators; and a third insulator adapted to extend from the attachment means for maintaining the upgrade loop a predetermined distance from the support structure.

These objectives and advantages are obtained by the improved method of the present invention, the general nature of which may be stated as including disconnecting the conductor from the support structures; mounting attachment means to said support structure; attaching first and second insulator strings to said attachment means; and dead-coding the conductor at spaced locations to the insulator strings on opposite sides of the attachment means to form a conductor loop extending between said insulator strings.

BRIEF DESCRIPTION OF THE DRAWINGS

The preferred embodiments of the invention, illustrative of the best modes in which applicants have contemplated

3

applying the principles, are set forth in the following description and are shown in the drawings and are particularly and distinctly pointed out and set forth in the appended claims.

FIG. 1 is a diagrammatic perspective view showing a first embodiment of the apparatus and method for upgrading electric power lines of the present invention;

FIG. 2 is an enlarged fragmentary top plan view of the apparatus of FIG. 1 removed from the tower;

FIG. 3 is an elevational view of the apparatus of FIG. 2;

FIG. 4 is a side sectional view looking in the direction of arrows 4-4, FIG. 3;

FIG. 5 is a diagrammatic perspective view of a second embodiment of the apparatus and method of the present invention;

FIG. 6 is a diagrammatic perspective view of a third embodiment of the method and apparatus of the present invention;

FIG. 7 is a diagrammatic perspective view of a fourth embodiment of the method and apparatus of the present invention; and

FIG. 8 is a diagrammatic perspective view of a prior art suspension insulator string used to support the electrical conductor prior to being upgraded by the method and apparatus of the present invention.

Similar numerals refer to similar parts throughout the drawings.

DESCRIPTION OF THE PREFERRED EMBODIMENTS

The apparatus for increasing electrical conductor clearance is indicated generally at 1 in FIG. 1, and is shown supporting a usual electrical conductor or power transmission line 2. Apparatus 1 is shown attached to a usual support structure or electrical tower 5 which includes a plurality of outwardly extending support arms 6. Apparatus 1 can utilize the existing suspension insulator string 8 (FIG. 8) when the voltage through conductor 2 is upgraded, for example, from 138 kV to 230 kV. Suspension insulator string 8 suspends conductor 2 a horizontal distance "A" from support structure 5, a vertical distance "B" from arm 6 of support structure 5, and a vertical distance "C" from the underlying support arms 6. Distances A, B and C must be increased when the voltage through conductor 2 is upgraded to prevent arcing and circuit de-energization between the conductor and the support structure and to meet certain minimum clearance requirements. Further, the catenary length of conductor 2 which extends between adjacent support structures 5 must be raised approximately 2-3 feet when the voltage is upgraded for example, from 138 kV to 230 kV to provide sufficient clearance from the ground and other underlying objects. Conductor 2 is shown in FIG. 8 connected to suspension insulator string 8 and is attached to the bottom thereof by a usual suspension clamp (not shown).

In accordance with one of the features of the invention, apparatus 1 is shown particularly in FIGS. 2-4, and includes first and second insulator strings 10 and 12, respectively. Insulator strings 10 and 12 are of the usual suspension type of insulators as insulator string 8 of FIG. 8, and include a plurality of interconnected ball and socket disc insulators 14. A dead end strain clamp 18 is mounted to a first end 20 of each insulator string 10 and 12 by a socket eye 22. Clamps 18 dead end conductor 2 at first ends 20 of insulators strings 10 and 12 and form a conductor upgrade loop 21 therebetween. Dead end strain clamps 18 preferably are constructed

4

from lightweight, high strength aluminum alloy, commercially available, and include keeper piece (not shown) and a plurality of U-bolts 23 which extend around and clamp conductor 2 to clamps 18. Socket eyes 22 extend into the devices of clamps 18 and are secured therein by a pin and cotter key assembly 25. Socket eyes 22 preferably are constructed of a hot dipped galvanized ductile iron which are commercially available.

A triangular yoke plate 24 is positioned intermediate first and second insulator strings 10 and 12, respectively, and is connected to a second end 26 of each insulator string 10 and 12 by a chain eye/chain eye hot line extension link 28. Extension links 28 include an oval-shaped chain eye 30 on each end thereof, and preferably are forged from a high-strength steel protected by a heavy coating of hot-dip galvanizing, such as those available commercially. A ball Y-clevis 32 extends from second end 26 of each insulator string 10 and 12 and includes a curved bolt, nut and cotter key assembly 34 which extends through one chain eye 30 to attach extension links 28 to insulator strings 10 and 12. A generally U-shaped anchor shackle 36 preferably manufactured from a galvanized steel, extends through the other chain eye 30 of extension link 28 and includes a nut and bolt assembly 38 which attaches the anchor shackle to yoke plate 24, orienting the plane of yoke plate 24 and the balance of the insulator hardware.

A vertical suspension insulator string 42 extends upwardly from the top of yoke plate 24 to support apparatus 1 from support structure 5 as described below. Insulator string 42 includes a plurality of usual interconnected disc insulators 43, which are similar to disc insulators 14 of insulator strings 10 and 12, and is attached to yoke plate 24 by a socket Y-clevis 44. Socket Y-clevis 44 includes a curved bolt, nut and cotter key assembly 46 which extends through an opening (not shown) formed in yoke plate 24 to attach insulator string 42 to the yoke plate. A ball Y-clevis 48 extends from the top of insulator string 42 and includes a curved bolt, nut and cotter key assembly 50, which attaches insulator string 42 to arm 6 of support structure 5.

A horizontal line post insulator 52 is rigidly mounted to the surface of yoke plate 24 and is angled outwardly and downwardly therefrom. Line post insulator 52 includes a plurality of rigidly connected porcelain insulator sections 56 and is attached to yoke plate 24 by an arm 54. A usual conductor clamp 58 is mounted on and extends from the outer free end of line post insulator 52 and connects line post insulator 52 to a center section of conductor upgrade loop 21. The extra conductor length, required to form the curved upgrade loop, may be utilized to remove conductor length from the adjacent spans and thereby raise the conductors in the spans and may not require the splicing or addition of any additional cable thereto.

Apparatus 1 is used to increase the electrical conductor clearances between conductor 2 and support structure 5, between conductor 2 and the ground and other underlying objects, and to increase the insulation level. When carrying out the method of the present invention, conductor 2 is unclamped from vertical suspension insulator string 8 (FIG. 8) and insulator string 8 is reused or removed from support structure 5 and replaced with a similar insulator string. Apparatus 1 preferably is pre-assembled on the ground before being mounted to support structure 5 in the configuration described above and shown in FIGS. 2-4. Ball Y-clevis 48 connects vertical insulator string 42 to support arm 6 of support structure 5 (FIG. 1). Vertical insulator string 42 connects to support arm 6 in a manner similar to that of insulator string 8 and requires no modification to support arm 6 or support structure 5.

5

The tension in conductor 2 is increased and the conductor is dead-ended on insulator 10 (FIG. 1) which shortens the catenary length of conductor 2 extending between insulator 10 and the adjacent support structure which, in turn, increases the conductor to ground clearance. Dead end strain clamp 18 of insulator string 10 receives tightened conductor 2 and U-bolts 23 are tightened around conductor 2 to dead-end conductor 2 at first end 20 of first insulator string 10. The tension in conductor 2 is then increased on the insulator 12 side of support structure 5 to a tension substantially equal to that of the tension on insulator 10, and dead end strain clamp 18 of insulator string 12 receives tightened conductor 2. U-bolts 23 are tightened around conductor 2 to dead-end conductor 2 at end 20 of second insulator string 12 forming conductor upgrade loop 21 between first ends 20 of first and second insulator strings 10 and 12, respectively.

The shifted length of conductor 2 which is achieved from increasing the tension therein, with the resultant shortening of the catenary lengths thereof on both sides of structure 5, may provide the extra wire or conductor needed to form loop 21 eliminating in most instances, the need to splice additional wire in forming loop 21.

Conductor clamp 58 is attached to conductor upgrade loop 21 intermediate dead end strain clamps 18 and first and second insulator strings 10 and 12, respectively, which extend substantially in-line with conductor 2 on each side of support structure 5. Conductor 2 applies a substantially equal outward tension on insulator strings 10 and 12 with no tension applied to upgrade loop 21. Line post insulator 52 retains upgrade loop 21 of conductor 2 an increased distance "D" (FIG. 1) away from support structure 5 and increased distances "E" and "F" away from support arms 6. Tightening conductor 2 a specific amount on each insulator string 10 and 12 shortens the catenary length of conductor 2 on both sides of support structure 5 to provide the needed additional wire for loop 21.

A second embodiment of apparatus 1 is shown in FIG. 5 and indicated generally at 64. Apparatus 64 is similar to apparatus 1 and includes first and second insulator strings 10 and 12, vertical insulator string 42 and a yoke plate 24a which is generally similar to yoke plate 24. Apparatus 64 is free of line post insulator 52 which extends between yoke plate 24a and conductor loop 21 of apparatus 1. Conductor 2 of FIG. 5 is of a substantially rigid material in order to create a stiff loop between dead end clamps 18 of insulator strings 10 and 12 which prevents upgrade loop 21 from bending downward eliminating the need for post insulator 52.

A third embodiment of the present invention is shown in FIG. 6 and is indicated generally at 68. Apparatus 68 is similar to apparatus 1 of FIG. 1 and includes insulator strings 10 and 12, a yoke plate 24b which is generally similar to yoke plate 24, vertical insulator string 42 and a pivotally mounted solid line post insulator 53. Apparatus 68 further includes a tension insulator string 70 which extends between arm 6 of support structure 5 and conductor clamp 58 of pivoting line post insulator 53. Tension insulator string 70 is similar in construction to insulator strings 10 and 12. Insulator string 70 assists the pivotally mounted line post insulator 53 and insulator 42 in mounting loop 21 in its desired position to maintain the separation from the adjacent structure.

A fourth embodiment of the present invention is shown in FIG. 7, and is indicated generally at 72. Apparatus 72 is generally similar to apparatus 1 of FIG. 1 and includes first and second insulator strings 10 and 12, yoke plate 24 and

6

line post insulator 52. Apparatus 72 is free of vertical insulator string 42, with yoke plate 24 being directly attached to arm 6 of support structure 5 by a pair of commercially available shackles. The omission of vertical insulator string 42, as is present on existing strain towers, allows apparatus 72 to further increase the conductor to ground clearance by raising conductor 2 between adjacent support structures 5. First and second insulator strings 10 and 12 and line post insulator 52 attach to yoke plate 24 in the same manner as that of apparatus 1.

The method and apparatus of FIGS. 1 and 5, without vertical string 42, and the arrangement shown in FIG. 7, can be applied to existing strain or dead-end towers in order to achieve the same results discussed above.

It is understood that if suspension insulator string 8 (FIG. 8) matches the specification required by apparatus 1, suspension insulator string 8 may be used in place of vertical insulator string 42. Conductor 2 is unclamped from the suspension clamp and the suspension clamp is removed from suspension insulator 8. Socket Y-clevis 44 is attached to the bottom of insulator 8 and yoke plate 24 is mounted thereto. First and second insulator strings 10 and 12 are clamped to conductor 2 as described above.

Accordingly, apparatuses 1, 64, 68 and 72 include first and second insulator strings 10 and 12, respectively, which attach at first ends 20 to conductor 2 forming conductor upgrade loop 21 therebetween. Additionally, insulator strings 10 and 12 dead end conductor 2 on respective sides of support structure 5 using dead end strain clamps 18, decreasing the catenary length of conductor 2 between adjacent support structures which, in turn, increases the conductor to ground clearance. Further, strings 10 and 12 extend substantially in-line with conductor 2 and the conductor applies a substantially equal outward tension on each of the insulator strings. Also, line post insulator 52 of apparatuses 1 and 72 and pivoting line post insulator 53 of apparatus 68 holds conductor loop 21 outwardly away from support structure 5 and increases the clearance therebetween. Moreover, apparatus 1 and particularly upgrade loop 21, can be used on double circuit and single circuit configurations having a vertical phase arrangement and on some single circuit configurations having a horizontal phase arrangement. Furthermore, the apparatuses combine standard hardware utilized by those skilled in the electrical conductor art in a novel configuration.

Accordingly, the improved apparatus and method for increasing electrical clearances and insulation lengths on power line structures are simplified, provide an effective, safe, inexpensive, and efficient device which achieves all the enumerated objectives, provides for eliminating difficulties and costs encountered with prior devices and methods, and solves problems and obtains new results in the art.

In the foregoing description, certain terms have been used for brevity, clearness and understanding; but no unnecessary limitations are to be implied therefrom beyond the requirement of the prior art, because such terms are used for descriptive purposes and are intended to be broadly construed.

Moreover, the description and illustration of the invention is by way of example, and the scope of the invention is not limited to the exact details shown or described.

Having now described the features, discoveries and principles of the invention, the manner in which the improved apparatus and method for increasing electrical clearances and insulation lengths on power line structures is constructed and used, the characteristics of the construction, the

advantageous, cost effective, and new and useful results obtained, the new and useful structures, devices, elements, arrangements, parts, combinations and method steps are set forth in the appended claims.

We claim:

1. An apparatus for increasing electrical conductor clearances from a grounded support structure, ground and underlying objects, said apparatus including:

first and second insulators dead-end clamped at first ends to the electrical conductor and extending substantially in line with said conductor, a section of said conductor forming an outwardly extending upgrade loop between the first ends of said first and second insulators;

attachment means for mounting said first and second insulators on the support structure at second ends of the insulators;

insulator means for insulating the attachment means from said grounded support structure; and

a third insulator adapted to extend from the insulated attachment means for maintaining the upgrade loop a predetermined distance from the grounded support structure.

2. The apparatus defined in claim 1 in which the first and second insulators are string insulators pivotally attached to the insulated attachment means, each of said first and second insulators including a plurality of interconnected disk insulators.

3. The apparatus defined in claim 2 in which the attachment means includes a plate attached to the second ends of the insulators.

4. The apparatus defined in claim 3 in which the third insulator is a rigid post insulator attached to the plate and extending between said plate and the upgrade loop.

5. The apparatus defined in claim 3 in which the insulator means is a string insulator which extends between the plate and the support structure.

6. The apparatus defined in claim 5 in which the third insulator is a post insulator rigidly attached to the plate and extending between said plate and the upgrade loop.

7. The apparatus defined in claim 6 which further includes a fourth insulator adapted to extend between the support structure and the upgrade loop.

8. The apparatus defined in claim 3 in which the plate is a triangular-shaped yoke plate.

9. The apparatus defined in claim 1 in which the third insulator is a rigid post insulator extending between said attachment means and the upgrade loop; and in which the insulator means is a string insulator adapted to extend between the support structure and the attachment means.

10. The apparatus defined in claim 1 in which the third insulator is a rigid post insulator extending between the attachment means and the upgrade loop.

11. The apparatus defined in claim 1 in which the third insulator is a post insulator adapted to extend between the attachment means and the upgrade loop; in which the insulator means is a string insulator adapted to extend between the support structure and the attachment means; and further including a fourth insulator which is a string insulator adapted to extend between the support structure and the upgrade loop.

12. In combination, a support structure for supporting an electrical conductor and an apparatus mounted on said support structure for increasing electrical clearances between said electrical conductor and said support structure and underlying objects, said apparatus including first and second insulators dead-end clamped at first ends to the electrical conductor forming an upgrade loop between the first ends of said first and second insulators, said upgrade loop extends outwardly away from said support structure; attachment means for mounting said first and second insu-

lators on the support structure at second ends of the insulators; insulator means for insulating the attachment means from the support structure; and a third insulator extending from the attachment means for maintaining the upgrade loop a predetermined distance from the support structure.

13. The combination defined in claim 12 in which the insulator means is a string insulator extending between the support structure and the attachment means.

14. The combination defined in claim 13 in which the third insulator is a rigid post insulator extending between said attachment means and the upgrade loop.

15. The combination defined in claim 12 in which the third insulator is a rigid post insulator extending between the attachment means and the upgrade loop.

16. The combination defined in claim 14 in which a fourth insulator which is a string insulator extends between the support structure and the upgrade loop.

17. A method for upgrading an electrical conductor mounted on and extending between spaced support structures, said method including the steps of:

disconnecting the conductor from one of the support structures;

mounting attachment means to a vertical insulator string, said vertical insulator string being attached to said one support structure to insulate the attachment means therefrom;

attaching first and second insulator strings to said insulated attachment means;

dead-ending the conductor at spaced locations to the first and second insulator strings on opposite sides of the attachment means to form a conductor loop extending between said first and second insulator strings; and

attaching a third insulator between the insulated attachment means and the conductor loop, said third insulator being insulated from the one support structure by the attachment means.

18. The method defined in claim 17 further including the step of attaching the vertical insulator string between said one support structure and the attachment means.

19. The method defined in claim 17 further including the step of attaching a fourth insulator string between said one support structure and the conductor loop.

20. The method defined in claim 17 in which the step of disconnecting the conductor from one of the support structures further includes the step of disconnecting the conductor from the vertical insulator string, said vertical insulator string being previously mounted to said one support structure; and further including the step of attaching the attachment means to said vertical insulator string.

21. An apparatus for increasing electrical conductor clearances from a grounded support structure, ground and underlying objects, said apparatus including:

first and second insulators dead-end clamped at first ends to the electrical conductor and extending substantially in line with said conductor, a section of said conductor forming an outwardly extending upgrade loop between the first ends of said first and second insulators;

attachment means for mounting said first and second insulators on the support structure at second ends of the insulators; and

a third insulator adapted to extend between the grounded support structure and the attachment means for insulating the attachment means from said grounded support structure, said third insulator vertically supports and insulates the attachment means, the first and second insulators and the conductor and upgrade loop from the grounded support structure.

Congested Paths Within California EHV Transmission System

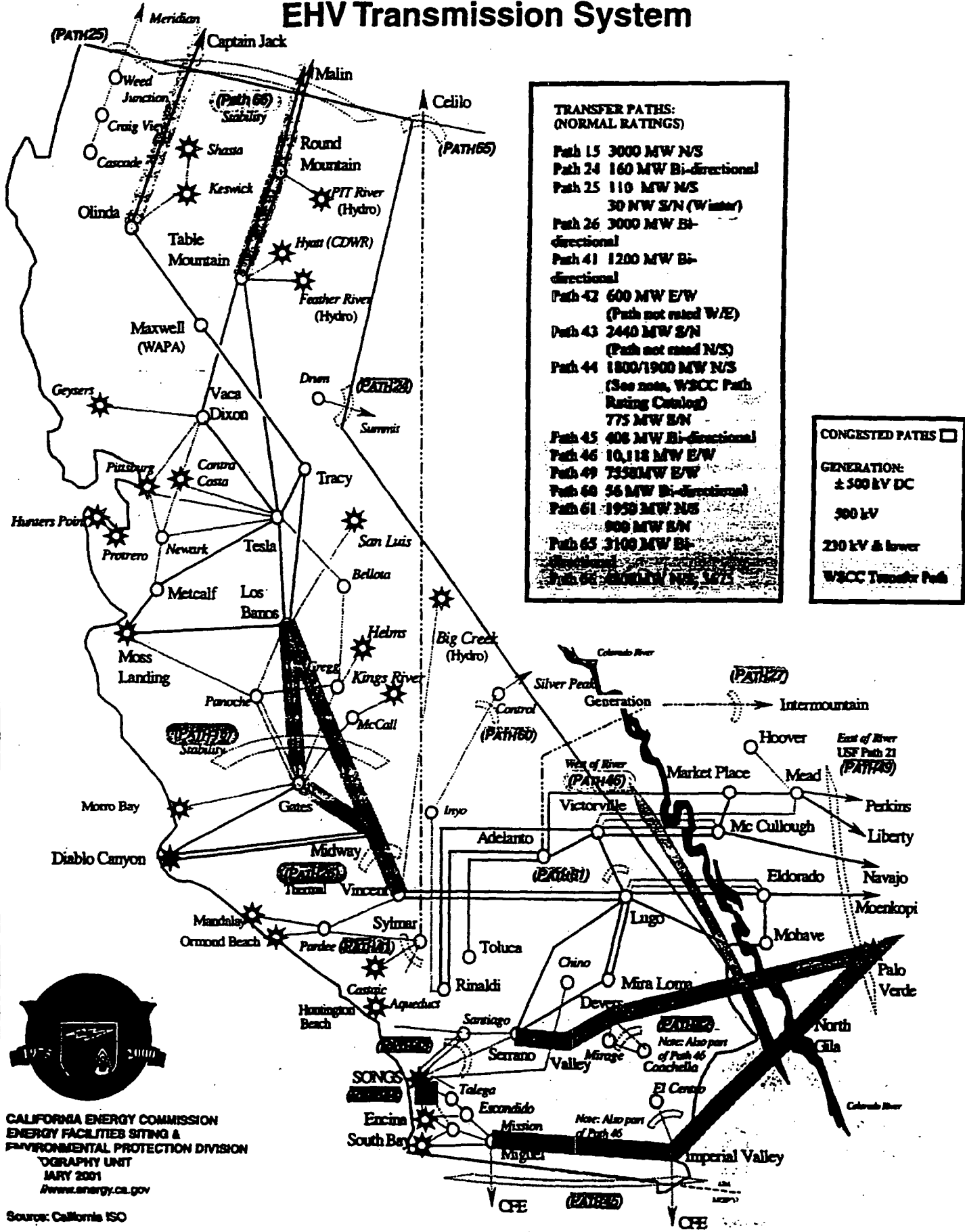

**TRANSFER PATHS:
(NORMAL RATINGS)**

- Path 15 3000 MW N/S
- Path 24 160 MW Bi-directional
- Path 25 110 MW N/S
30 MW S/N (Winter)
- Path 26 3000 MW Bi-directional
- Path 41 1200 MW Bi-directional
- Path 42 600 MW E/W
(Path not rated W/E)
- Path 43 2440 MW S/N
(Path not rated N/S)
- Path 44 1800/1900 MW N/S
(See note, WSCC Path Rating Catalog)
775 MW S/N
- Path 45 406 MW Bi-directional
- Path 46 10,118 MW E/W
- Path 49 7358 MW E/W
- Path 60 56 MW Bi-directional
- Path 61 1930 MW N/S
900 MW S/N
- Path 65 3100 MW Bi-directional
- Path 66 3000 MW N/S, S/N

CONGESTED PATHS

GENERATION:

- ± 500 kV DC
- 300 kV
- 230 kV & lower
- WSCC Transfer Path

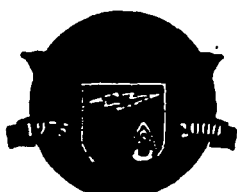

CALIFORNIA ENERGY COMMISSION
ENERGY FACILITIES SITING &
ENVIRONMENTAL PROTECTION DIVISION
GEOGRAPHY UNIT
MAY 2001
www.energy.ca.gov

Source: California ISO
FILE:TL_BCONGEST_2.d

b6

[]

04 APR 25 PM 4:48
Doyne Loyd, MD, PC

April 25, 2001

Senator Strom Thurmond
217 Russell Senate Office Bldg
Washington, DC 20510-4001

Dear Senator Thurmond:

Re: Energy Policy and omnibus energy billed introduced by Senator Murkowski

I have serious concerns about our lack of a coherent energy policy. President Bush would like to open more areas in Alaska. I can remember all too well the original arguments over the Alaska pipeline and how it would free us from dependence on foreign oil. Of course we are even more dependent upon fossil fuels now than we were then, particularly foreign oil. We were simply fooling ourselves. We ran pipeline through half of AK and we are worse off now than we were then. We should have left AK to the Moose and Bears and developed renewable energy resources. It would have been a lot easier 30 years ago to begin programs than it will be now. (Bush has also done other little things like roll back the SEER standards for air conditioners when every manufacturer of units has standard models that exceed the standard that was to be implemented.)

And over the past few years we have let the auto makers off the hook by not enforcing current CAFE standards and by not increasing them as they should be. I remember in 1972 when automakers faced new regulations how they moaned and groaned at the sheer impossibility and impracticality of the standards. That same year Honda began shipping cars that met the 1976 standard that could not be met. Unfortunately, American industry has a long history of attempting to sabotage appropriate environmental standards or forestall their introduction.

A few years ago, the Republicans were bitter about our national debt, a debt that would saddle our children and grandchildren and perhaps several generations to come! What about environmental debt? It appears that we will be saddling our children with a much warmer environment, rising ocean levels, increased mercury and other pollutants from old power plants, the destruction of more wilderness areas, etc. We have already polluted many lakes and streams in the NC and SC area. Every year I read about what fish we shouldn't eat out of local lakes and rivers. The last time I went to the Smokies, it was like going to Los Angeles. Is this the legacy we want to leave our children? Polluted National Parks and wilderness areas, polluted streams and lakes, hotter weather, etc.

So all of this talk about the importance of opening new fields in AK is nonsense. I bought it the first time around. I don't buy it now. I was sympathetic to the car companies (the day I read that Honda already met the 76 standard, I was reading an Auto trade magazine in my father's office in his farm equipment and car dealership) the first time around. I'm not sympathetic today. We have had 30 years to prepare and we haven't done it. The last major measure energy measure I can recall was the reduction in speed limits on the highways to 55 in 1974 and I got a ticket the very first night driving 65 in what had been a 65 the day before.

Save the next generation from the foolishness of the present. Enact reasonable energy policies. For example, I see that bills have been introduced to give tax credits to homeowners who use renewable energy sources such as solar cells. Back these bills. If

April 25, 2001

Page 2

they have foolish parts, amend them and then enact them. But for our children's and grandchildren's sake don't drill in Alaska or other national parks, forests or wilderness areas. If anything create more protected areas and surely not less. You know the old saying—Fool me once, shame on you; fool me twice shame on me. I hope you won't buy the fossil fuel industry, the electric energy and car companies' arguments. They are only interested in short-term profits. (Ford for example has been running ads about how environmentally friendly their SUV's are. Of course SUV's are very inefficient means of transportation, expensive to maintain, and dangerous for the average housewife to drive in an emergency. AND I LOVE 4-WHEEL DRIVE VEHICLES. I have two now). They could care less about the debt they will leave to future generations.

Sincerely,

Doyle Loyd MD

29709

001-011640 5/7/01 12:02pm

(b)(6)

April 25, 2001

Mr. Spencer Abraham
Secretary of Energy
Washington, DC

Dear Mr. Secretary,

It is rare if ever I write to a public official but I had to respond to an excerpt of an article that was originally published in the Washington Post in which you outlined your "energy policies". I am enclosing the article that appeared in our local newspaper. Your philosophy on "energy" is remarkably similar to Mr. Richardson's energy policy of the Clinton administration.

I read the article several times. You compared the Clinton energy policies with the current administration policies. I can't see one bit of difference. Like Mr. Richardson's policy you don't offer any solutions to the energy crisis. You both take a laissez-faire approach to the current situation. Have you or Mr. Bush applied any diplomatic pressure to the OPEC Oil Cartel to increase oil production? I am paying \$1.78 per gallon and it is only April. Look at the recent report of the profits made by Mobil Oil-a staggering 44% increase in profit for this fiscal quarter. Are they losing money or just gouging the American people? Perhaps you might consider resigning and let some more competent person take the position as Secretary of Energy.. We couldn't be any worse off .

In the campaign of 2000 the Republicans took the Democrats to task for not having an energy policy. What has the Republicans done to bring down the high cost of energy? Absolutely nothing.. just more rhetoric coming from the White House and your office.

I am a registered Republican in Orange County, New York and I voted for Mr. Bush thinking he was going to be a dynamic take charge president. I am very disappointed with him, his policies and the people he has appointed . He has done little or nothing in his first 100 days in office. He certainly has been a hands-off president.

In the coming election of 2004 I along with many others will stay at home instead of voting. I am sure Mr. Bush will lose the 2004 election to any Democrat unless he shows people like myself that he is able to solve the many problems that our nation faces. Can't you people see we are heading for a economic recession, and one of the primary causes of our failing economy is the high cost of energy. I am very sorry that I did not vote for Mr. Gore in the last election.

Sincerely (A disgusted citizen)

Bruce Kroog

29710

DOE

Global warming

(b)(6)

April 29, 2001

George W. Bush, President of the United States
The White House
Washington D.C. 20500

Dear President Bush:

I would like you to reconsider your recent actions with regard to climate change and energy policy. The U.S. has a moral obligation to take action on global warming.

Reducing greenhouse gas emissions must be one of the nation's highest priorities. We must be the leader in participating in fair and effective international agreements on energy policy.

By following the suggestions I have proscribed you will be supporting a major effort of the religious communities in our country.

Sincerely,

Joan R. Vick

Joan R. Vick

29711

2001-011584 5/4/01 4:06pm

May 1, 2001

Dear Mr. Spencer Abraham,

I am writing as a very concerned citizen about the direction the Bush administration is going with regards to energy policy and the environment. I believe that the president and vice president's jobs, as elected officials running the highest office in our nation, are to represent the will of the people, and to act accordingly. If you look at polling numbers, the vast majority of Americans are not in support of Mr. Bush's recent decisions regarding the Kyoto Protocol, CO2 emissions, and oil drilling in the ANWR.

It greatly disturbs me to read of Mr. Cheney making such statements as, "The aim here is efficiency, not austerity." Who said anything about austerity? How about common sense? How about some tax-based incentives for buying fuel-efficient vehicles, retrofitting homes with solar voltaic panels, upgrading windows, doors, insulation, etc. to make homes more efficient?

I am not advocating a step backwards, or a reduction in Americans' standard of living, which we all take for granted until times like these. I am simply suggesting a common-sense approach to a multi-faceted energy source exploration, which necessarily **MUST** include adequate federal funding for research into alternative fuel sources. The sharp cuts in funding we have seen to these important programs are where we find ourselves taking a step backwards. Progress can never be made with this extreme conservatism. I am sure that Mr. Bush's and Mr. Cheney's friends in the big oil industry are applauding their steps to minimize research into alternative, renewable, sustainable, and clean energy sources. But most Americans realize that this quick-fix, band-aid approach, such as oil exploration in the ANWR is not the answer. In fact, scientists agree that the best-case scenario, for all the havoc posed on one of the most beautiful and sensitive ecological areas left on earth, would be for 6 years worth of oil for the U.S., in only single-digit percentage of overall supply. The worst-case scenario is only 6 months (single-digit percent supply)! Could this perhaps be one case when conservation/efficiency-based incentives could make more of a difference than simply drilling for 6 months more oil? I think so.

I firmly believe that we as a nation are intelligent enough, passionate enough about our natural areas, and inventive enough to successfully explore new, forward-thinking approaches to solve this problem. Scientists have worked hard for decades to try to move forward into a cleaner, more sustainable, and more responsible way of providing energy to our citizens, and thus increasing the quality of life for all Americans. Please let them continue their efforts -- they will be greatly hindered without your help.

Sincerely,

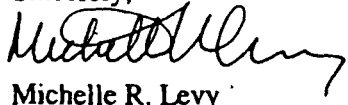

Michelle R. Levy

(b)(6)

29712

2001-011775 May 7 p 4:34

Minister
of Natural Resources Canada

Ministre
des Ressources naturelles Canada

Ottawa, Canada K1A 0E4

MAY 1 2001

The Honourable Spencer Abraham
Secretary of Energy
Government of the United States of America
Forrestal Building
1000 Independence Avenue, Southwest
Washington, D.C. 20585

Dear Secretary Abraham,

It was a pleasure to meet with you in Washington on February 26 and again in Mexico City on March 8, 2001. These were the first of what I am sure will be many productive meetings and contacts in the months ahead. I appreciated your openness and willingness to work with us across the broad range of matters that we discussed.

I am writing now to follow up on some of the topics raised at our first meeting. I hope that the following reflections might be useful for our future discussions, and might also provide points of reference for ongoing meetings of our officials.

Canada and the United States face many similar challenges in the energy sector. Our large land masses, variable and often harsh climates and energy-intensive resource industries place great demands on our energy systems. Economic growth has led to increased energy demand and higher prices for both of us. Our oil prices are established in a global oil market, and have risen with increased global demand and tighter supply constraints by OPEC. While natural gas prices are set in a North American context, recent and significant increases have caused consumer concern and raised questions about the economic viability of switching to this cleaner form of energy.

Canada and the United States also face similar environmental challenges associated with energy production and use. These include regional environmental concerns such as acid deposition and ground-level ozone, and global challenges such as climate change. The interface between energy production and use and the broader clean air agenda will require co-ordination. Environmental concerns are making siting and transmission of energy more difficult, even in areas facing shortages.

Canada

29713

All of these challenges require our attention to both energy supply and energy demand. I was pleased to hear that your energy policy review will address both of these critical components.

The guiding principle of Canada's energy policy is sustainable development, which balances economic, environmental and social objectives. Canada's energy policy is market-oriented. Our policy reflects distinct jurisdictional responsibilities under Canada's constitution, whereby the federal government is responsible for interprovincial and international energy matters, while provinces own resources and manage resource development and commerce within their borders. Our energy markets operate according to rules established by domestic and international agreements, including the NAFTA.

It is within the context of this broad policy framework that we will want to work with you, and with Mexico, on a bilateral basis, and more broadly to expand and improve the functioning of markets and to pursue sustainable development objectives.

I welcome the recognition that you and President Bush have given to Canada as a secure source of energy supply and a reliable business partner. Canada currently provides about 8% of U.S. oil consumption, about 14% of U.S. natural gas consumption, and about 35% of U.S. uranium consumption. Canada's clean energy exports, particularly of natural gas, electricity (generated largely from hydro sources) and uranium, help the U.S. to meet its energy needs while minimizing air pollution and greenhouse gas emissions. And there are many exciting opportunities yet to be realized, notably:

- oil and natural gas production off Canada's east coast is starting to make a significant contribution to energy supply and security in the northeastern states, but there is potential for more;
- Canada's oil sands are a readily accessible source of over 300 billion barrels of economically recoverable oil (comparable in size to the conventional oil reserves of Saudi Arabia), where technological developments have steadily reduced the costs of production to a current level of about US\$13-18 per barrel of synthetic crude oil;
- there is significant natural gas potential in Canada's north which we would like to ensure does not get stranded as we consider proposals to bring gas from Alaska and Canada's north by pipeline to Canada and the lower 48 states;

- there are at least 417,000 tonnes of recoverable uranium resources in Northern Saskatchewan; this represents over 40 years of supply of uranium at present output rates; and
- increasing interconnection of our electricity grids has the potential to add flexibility and resiliency, to create economies, and to facilitate the introduction of new sources of supply.

We see these and other opportunities as important elements in Canada's own energy security, and they could also play an important role in the wider North American context through the expansion of our energy trade.

Canada welcomes the prospect of expanding this trade within the framework of the NAFTA. Canada and the U.S. have made substantial progress in establishing open energy markets between our countries, and we need to continue to work together at this. As I noted at our first meeting, we see this as a process of enabling our North American energy markets to work better. This, of course, does not mean adopting common energy policies, but rather striving for compatibility where it is needed to facilitate the freer flow of our energy-related trade, thereby encouraging investment in energy supply. For example, we have developed good compatibility in our processes for pipeline certification. We are also developing compatible regimes for electricity reliability that will facilitate the further integration of the North American electricity market.

In the past, however, there have also been some initiatives and proposals by various U.S. jurisdictions that in our view have had, or could have had, the effect of hampering the freer flow of our energy trade. For example, in the electricity area, there have been initiatives and proposals at both the federal and state levels in the U.S. for reciprocity requirements and renewable portfolio standards that are inconsistent with obligations under our trade agreements, including the NAFTA. We need to continue to work together, at both the federal and state/provincial levels, to reduce and avoid barriers while respecting each others' legitimate jurisdictional authority.

Energy efficiency is another major area of opportunity for both of us. It can ensure that we make the best use of our energy supplies, thus enhancing our security and economic efficiency, and it is also the first line of action to pursue our environmental objectives. I would hope that we could work together – particularly, again, in ensuring that where our markets are linked, our standards and regulations are compatible. A good example of this is in improving standards for energy efficiency and fuel efficiency for products, such as motor vehicles, which are sold throughout North America. In this respect, we would like

to renew and enhance our Memorandum of Understanding (MOU) on vehicle fuel efficiency and alternative transportation fuels at the earliest opportunity.

The advancement of science and technology is another key area for cooperation and one that underpins our continuing ability to both access and use our energy supplies in a cost-effective and environmentally sound manner. Indeed, this must be the foundation of our sustainable development in the longer term. Canada and the U.S. have many strong common interests in science and technology advancement for both energy supply and energy efficiency. This is particularly important in the context of our need to address climate change through improved efficiency, the cleaner use of fossil fuels, and the promotion of less carbon-intensive, and renewable, forms of energy. The future of nuclear energy in North America has also been the subject of recent discussion, with consideration being given to a next generation. We look to expanding and deepening our cooperation with you in energy research and technology development, notably through the MOU that currently exists between our Departments.

We also look forward to expanding our work with you in addressing environmental challenges and fulfilling our environmental responsibilities at both the regional level and global level. Climate change is a global problem that requires a global solution. For that reason, Canada has been an active player in international negotiations and has worked closely with the United States in pursuing common interests, particularly in the areas of sinks and the use of flexible mechanisms for cost-effective emission reductions. The new U.S. administration has expressed an interest in remaining engaged in international negotiations on ways to address climate change. I would hope that we will be able to continue to work together in pursuing initiatives in the energy sector that will significantly reduce CO₂ emissions. In addition, as I mentioned to you at our first meeting, we would like to find an equitable way of dealing with emissions from our clean energy exports. This would facilitate the expansion of energy trade to our mutual benefit.

In Canada, as in the U.S., energy development often has significant environmental and social implications for local communities, particularly for Aboriginal peoples. Their interests and engagement must be ensured in any new energy developments that affect them. In Canada's North, in particular, there is an interest in participating in new energy development, but also a strong concern to protect cultures and ways of life and the resources and environment on which they depend. Canada incorporates these interests through open and transparent processes of regulatory review, environmental impact assessment and cooperation with Aboriginal groups. Of course, Aboriginal interests transcend borders, and we would like to work with you to ensure that decisions made in both our countries respect these interests.

All of the issues I have addressed motivate our concern to ensure that, as you develop your energy policy, the common interests of our two countries are fully engaged and given scope for advancement in the future.

As we discussed at our first meeting, the bilateral Energy Consultative Mechanism among our officials is a vital arrangement which needs to be continued and strengthened. In this regard, I have asked my officials to consult with your staff on how best to reinvigorate this important mechanism.

I look forward to hearing of your progress in developing your new energy policy, and to discussing further with you opportunities for us to strengthen our energy cooperation, both bilaterally and on a broader basis.

Sincerely,

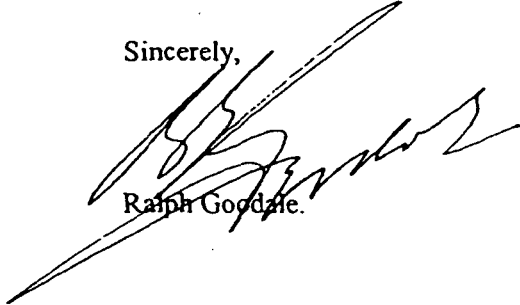
A handwritten signature in black ink, appearing to read 'R. Goodale', written over the typed name.

Ralph Goodale.

2001-011628 5/7/01 12:02pm

R.G. LOCKERT

] bb

2 May 2001

President George W. Bush and Vice President Richard Cheney
The White House
1600 Pennsylvania Avenue
Washington, DC 20500

RE: Outdated reliance on fossil fuels

Dear President Bush and Vice President Cheney:

Your insistence that the United States must continue to rely principally on fossil fuels is a great disappointment. An energy policy from the Twentieth Century is dangerous and inappropriate today. As the present Bush Administration acknowledges global climate change, industry emphasis—and profits—must be shifted immediately to renewables.

Some facts underlying the science: carbon dioxide traps in heat. For the last 10,000 years we have had the same amount of carbon dioxide in the atmosphere, ±280 parts per million. Until about the beginning of the last century, when we began to burn more coal and oil. That 280 ppm is projected to double this century. An intermediate concentration of 450, which most experts regards as inevitable, correlates with an increase in the global temperature of 2-4.5 degrees Celsius. (The last ice age was 2.7-5 degrees colder than our current climate.)

One of the great shames of your industry was the disinformation campaign waged since 1991 by fossil fuels interests. Western Fuels and other utilities launched a public relations program that year calling for radio and TV and local newspaper interviews with "greenhouse skeptics." The strategy papers for that campaign said explicitly that the campaign is "designed to reposition global warming as theory rather than fact." And more specifically that the campaign is designed to target "older, less educated men and young low-income women."

Even so, change comes. BP, Shell, Sunoco, Texaco, Ford, and Daimler-Chrysler have broken ranks with the industry and have begun working on fuel cell technology. As your Administration has admitted global warming is taking place, why not take a leadership position to address it meaningfully? Time is of the essence, and a quantum leap is needed.

Nuclear power is another failed Twentieth Century strategy. After half a century, we still have no reliable solution to the waste problem, decommissioning of plants continues to exceed cost estimates exponentially, and

29718

President George W. Bush and Vice President Richard Cheney
2 May 2001
Page 2

citizens are understandably unwilling to accept the health risks to their communities.

To preserve our climate in a hospitable state requires nothing less than ASAP replacing every car and power plant with renewable, climate-friendly energy sources. Climate change is not just an annoyance. It is the ultimate environmental impact. Our national responsibility is to lead the way in reducing the burning of fossil fuels, not increasing it.

I urge you to reexamine your energy policy and embrace the renewables of the future rather than the carbon-burning power of the past.

Sincerely,



R.G. Lockert

cc: ✓ Energy Secretary Spencer Abraham
Congresswoman Lynn Woolsey
Senator Barbara Boxer
Senator Dianne Feinstein
Governor Gray Davis
Assemblyman Joe Nation
State Senator John Burton

2001 MAY - 7 P 12:02

011628

29719