



U.S. Department of Energy
Grid Modernization Initiative

Grid Modernization Lab Call 2023

April 2023

Table of Contents

Introduction	3
Grid Modernization Priorities	3
Grid Modernization Lab Call Principles	5
Lab Call Funding by Office	5
Topic Area 1: Power and Control Electronics (PACE)	6
Description	6
Performance Targets	7
Topic Area 2: Cybersecurity for Architectures, Standards, and Practices (CASP)	9
Description	9
Topic Area 3: Quantum Facilities for Applied Computing, Sensing, and Security (qFACSS)	12
Description	12
Performance Targets	16
Topic Area 4: Equitable System Operation and Planning (ESOP)	18
Description	18
Performance Targets	19
Topic Area 5: Climate Impact on Energy Resources (CIER)	20
Description	20
Performance Targets	23
Proposal Review Criteria	24
Criterion 1: Technical Merit, Innovation, and Impact (50%)	24
Criterion 2: Research Approach and Adoption (30%)	24
Criterion 3: Team and Resources (20%)	25
Timeline and Process for Foundational Lab Call	25
Concept Specifications	26
Full Proposal Specifications	26

Introduction

The Grid Modernization Initiative (GMI) works across the U.S. Department of Energy (DOE) to address the research and development (R&D) challenges facing the 21st century grid. Modernizing the grid is essential for achieving the administration's goals of 100% clean electricity by 2035 and a decarbonized economy by 2050. The GMI focuses on developing new architectural concepts, tools, and technologies that will better measure, analyze, predict, protect, and control the grid, as well as enable the institutional conditions that allow for rapid development and widespread adoption of these tools and technologies.

In 2016, DOE announced the first Grid Modernization Lab Call—a comprehensive, \$220M, three-year plan to mobilize 87 projects across the country, bringing together DOE and the National Laboratories with more than 100 companies, utilities, research organizations, state regulators, and regional grid operators to pursue critical research and development in advanced storage systems, clean energy integration, standards and test procedures, and a number of other key grid modernization areas. In 2017, DOE announced up to \$32M over three years for seven projects to develop and validate innovative approaches to enhancing the resilience of electricity distribution systems, focusing on the integration of distributed energy resources (DERs), advanced controls, grid architecture, and emerging grid technologies at a regional scale. In 2019, the third DOE Grid Modernization Lab Call was announced with \$80M investment in six areas – Resilience Modeling; Energy Storage and System Flexibility; Advanced Sensors and Data Analytics; Institutional Support and Analysis; Cyber-Physical Security; and Generation. Additionally, several Offices within DOE have successfully conducted Lab Calls and Funding Opportunity Announcements (FOAs) on Office-specific Grid Modernization topics.

Grid Modernization Priorities

The United States needs a modernized grid. Decarbonization requires a diverse portfolio of clean energy technology generation options. A modern grid infrastructure will enable reliable and efficient transformations of the electric power system while also serving historically marginalized and disproportionately affected groups of people. The grid will be exceptionally adept at adapting to the climate crisis through the deployment of new technologies and infrastructure, supported by a workforce that has been developed intently to facilitate a transition to the most effective, efficient, and powerful grid seen to date. The grid must meet several power systems objectives based on these requirements. Clean energy integration reduces dependence on carbon-emitting fuels and inertia-heavy generators. Grid infrastructure expansion meets areas of the United States previously unserved. Managing electrification maintains consistent control and monitoring of electricity generation, transmission, and consumption. The grid must be reliable, resilient, and secure, and it must be affordable for adoption. GMI has defined six key pillars derived from the power system objectives to achieve the grid of the future: Devices & Integrated Systems; Operations; Planning; Markets, Policies, & Regulations; Resilient & Secure Systems; and Flexible Generation & Load.

Figure 1. GMI Priorities & Six Key Pillars

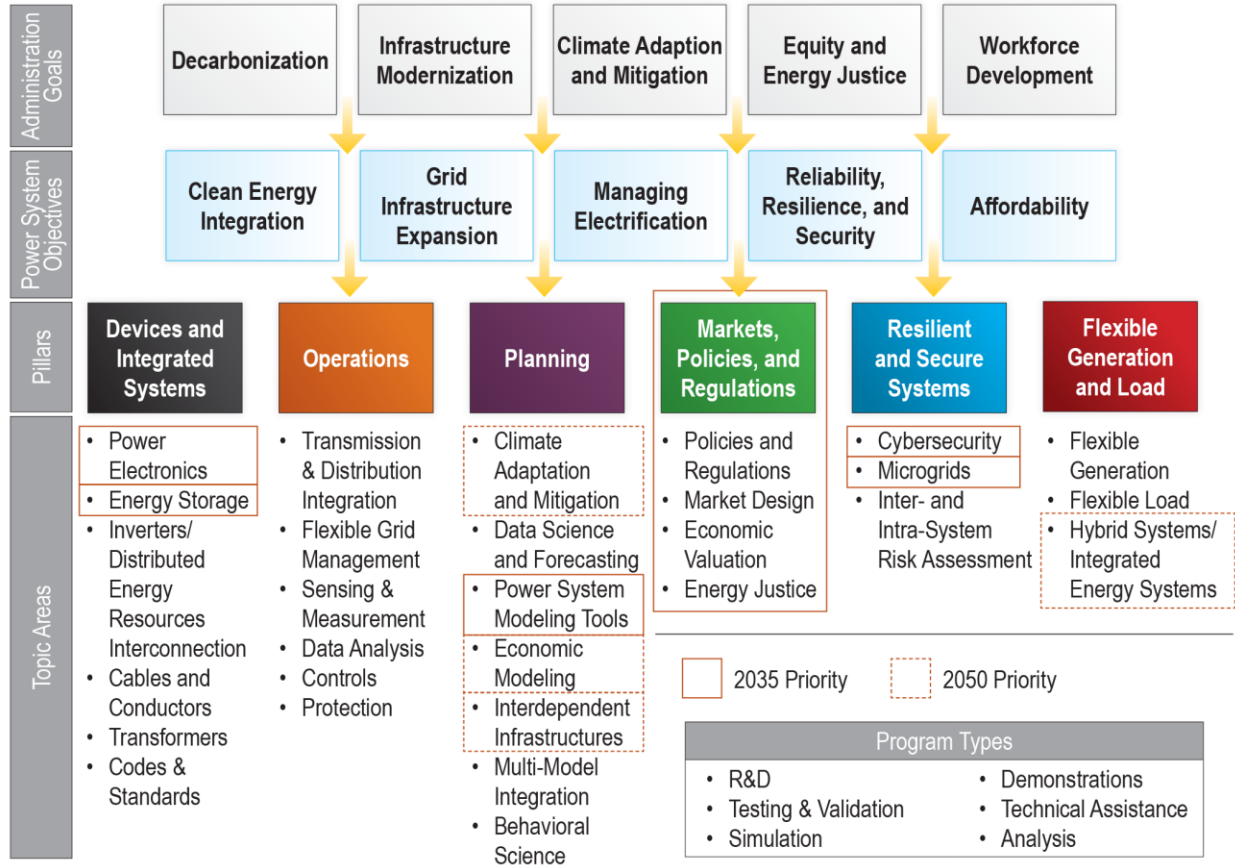

GMI uses multiple funding mechanisms to drive the development and adoption of grid technologies, including foundational lab calls, funding opportunity announcements (FOA), and other office specific activities. This is GMI’s Fiscal Year 2023 Foundational Lab Call, which aims to fill research gaps in the following five topic areas, based on the GMI priorities shown in the figure above:

- Topic Area 1: Power and Controls Electronics (PACE), in the Power Electronics area of the *Devices and Integrated Systems* Pillar
- Topic Area 2: Cybersecurity for Architectures, Standards and Practices (CASP), in the Cybersecurity area of the *Resilient and Secure Systems* pillar
- Topic Area 3: Quantum Facilities for Computing, Sensing, and Security (qFACSS), in the Power System Modeling Tools area of the *Planning* pillar
- Topic Area 4: Equitable System Operation and Planning (ESOP), in the Energy Justice area of the *Markets, Policies, and Regulations* pillar
- Topic Area 5: Climate Impact on Energy Resources (CIER), in the Climate Adaptation & Mitigation area of the *Planning* pillar

Grid Modernization Lab Call Principles

Each of the topics, and respective subtopics, have been identified as foundational to the future grid and support the research and development efforts of multiple DOE Offices. As a result, each Topic below will be funded by at least two DOE Offices. All lab call proposals must include at least two national laboratories. This will ensure that the DOE is effectively engaging with a broad spectrum of researchers from across the lab complex.

Lab Call Funding by Office

The Lab Call Topics will be supported by various DOE Offices as follows. Additional funding may be available at the discretion of DOE Offices.

Topic	PACE	CASP	QFACSS	ESOP	CIER	Total
OE	\$3,000,000	\$2,000,000	\$1,500,000	\$500,000	\$3,000,000	\$10,000,000
EERE	\$10,000,000	\$300,000	\$-	\$300,000	\$3,000,000	\$13,600,000
FECM	\$-	\$-	\$1,500,000	\$1,500,000	\$3,000,000	\$6,000,000
CESER	\$750,000	\$5,010,000	\$750,000	\$200,000	\$1,000,000	\$7,710,000
GDO	\$-	\$-	\$-	\$1,500,000	\$-	\$1,500,000
Total	\$13,750,000	\$7,310,000	\$3,750,000	\$4,000,000	\$10,000,000	\$38,810,00

Annual budgets are contingent on outcomes of project negotiations. Any funding after Year 1 is subject to appropriations.

Topic Area 1: Power and Control Electronics (PACE)

Supporting Offices: EERE, OE

	Year 1/Phase 1	Year 2/Phase 2	Year 3/Phase 3
TOTAL	\$5,000,000	\$5,000,000	\$3,750,000

Description

A proposed PACE-centric GMLC project would leverage components of laboratory-led 'Grid Shot' proposal presented at the Energy Earthshots™ National Lab Ideation Forum. The focus would be on addressing gaps in 'smart' medium-voltage (MV, 4.16kV-34.5kV) electrical interfaces critical to a modernized grid (see Figure 2) through development of a medium-voltage power and control electronics sub-system approach that is modular, scalable, and cost-effective. The sub-system could be used as a building block to interface distributed energy resources to the grid, and that is also scalable to higher voltages (>34.5kV) to support low-loss transmission. The approach

would be developed in concert with relevant stakeholders from academia, industry, and utilities to connect wind, solar, energy storage, and fuel-cells/electrolyzers to the grid; control power flow; and provide grid support/conditioning services. Activities would support technology development and demonstration at the sub-system and power-system levels, while leveraging concurrent advances in materials, components, and devices [e.g., Wide Band Gap Semiconductor (WBS)] through other programs (e.g., PowerAmerica).

Performance targets and success metrics would be developed to focus on achieving low-cost, along with high-efficiency, security, and reliability, while providing grid integration across a broad array of realistic use cases. Some specific roles for the labs would include:

- Leveraging current integrated systems test beds to safely evaluate and test reconfigurable power and control electronics sub-systems in terms of performance, durability, cost, and provided grid-services;
- Evaluating system integration and cybersecurity, while providing guidance in future developments in both hardware (e.g., WBS, Solid-State Transformers, etc.) and software;

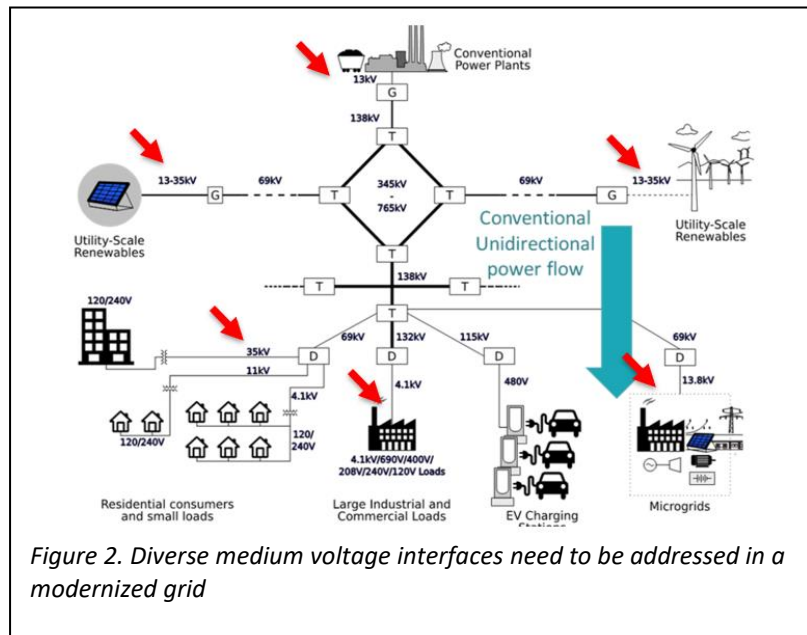

- Informing harmonization of component and system standards for interoperability and control of energy flows (e.g., IEEE-1547, IEEE-519, UL-1741, as well as state rules such as CA-21, HI-14, etc.);
- Providing analytics to evaluate stability, security, and optimization of system models and scalability to high voltage applications; and
- Providing assessments of the potential impact for enabling high-penetration of distributed energy resources on the grid and for addressing decarbonization goals and EJ40 priorities.

Specific tasks will include:

- **Stakeholder Engagement** (e.g. through meetings and workshops with stakeholders from utilities, government agencies, power electronics OEMs, and DER industries) to inform hardware/software designs concurrent with harmonization of standards;
- **Hardware/Software Design** of MV sub-system and associated DER interfaces (leveraging current technologies, but readily adaptable to next generation designs incorporating expected technology advances) – with clearly defined roles for each participating laboratory;
- **Hardware/Software Implementation**, including component fabrication/assembly and code development relevant to the MV sub-system and associated DER interfaces as well as evaluation (leveraging both physical and virtual testing capabilities) of components, interfaces, and integrated systems – with clearly defined roles for each participating laboratory;
- **Impact Analysis** on the potential impact of a modular, cost-effective, and scalable MV sub-system for enabling high-penetration of DERs on the grid and for addressing decarbonization goals and EJ40 priorities;¹ and
- **Gap Analysis** based on outcomes from hardware/software development and impact analysis, including identification of barriers for adoption of the MV sub-system and associated DER interfaces in grid modernization and opportunities afforded by implementation of hardware and software advances; and recommendation of expanded PACE-related national laboratory resources.

This project is expected to deliver high-impact results for advancing national grid-modernization priorities, including associated support of several of the DOE Energy Earthshots™ (such as Hydrogen, Long-Duration Storage, Industrial Heat, Floating Offshore Wind, among others).²

Performance Targets

Engagement Targets:

- Phases I/II – Cross-sectoral engagement with utilities, government agencies, PACE OEMs, and DER OEMs, including through successful workshops and reports, landscape

¹ [Justice40 Environmental Justice Initiative | The White House](#)

² [Energy Earthshots™ Initiative | Department of Energy](#)

assessment of MV interface status and key challenges, and establishment of advisory boards (specifics to be determined during project negotiations);

- Phases I/II – Updated and harmonized standards relevant to MV sub-systems and associated DER interfaces (specifics to be determined during project negotiations);
- Phase II - Impact analysis on MV sub-systems for enabling high-penetration of DERs on the grid and for addressing decarbonization goals and EJ40 priorities;
- Phase III - Gap analysis on barriers and opportunities to inform effective pathways forward; and
- Phase III - Delivery of a DOE-approved diversity, Equity, and Inclusion / EJ40 implementation plan

Technical Targets:

- Phases I/II - MV sub-system design report including baselines and targets for (specifics to be determined during project negotiations):
 - >97% efficiency
 - 40 year+ targeted lifetime at 90% up-time
 - interoperability with diverse generation, storage, and load assets
 - robustness against cybersecurity threats
 - achievable cost reductions in first-generation systems (i.e., those leveraging currently-available materials and components) and future systems (i.e., those leveraging anticipated next-generation materials and components)
- Phases II/III – Evaluation report on MV sub-system and associated DER interfaces including (specifics to be determined during project negotiations):
 - Hardware component fabrication and testing results
 - Interface and control software development and testing results
 - Integrated energy system evaluation results (physical and virtual), including: connections to wind, solar, energy storage, and fuel-cells/electrolyzers to the grid; control power flow; and provide grid support/conditioning services

Topic Area 2: Cybersecurity for Architectures, Standards, and Practices (CASP)

*Supporting Offices: CESER, OE, EERE, OTT**

	Year 1/Phase 1	Year 2/Phase 2	Year 3/Phase 3
Subtopic 1	\$800,000	\$800,000	\$800,000
Subtopic 2	\$800,000	\$800,000	\$800,000
Subtopic 3	\$470,000	\$1,020,000	\$1,020,000
TOTAL*	\$2,070,000	\$2,620,000	\$2,620,000

**Funding total may increase depending on A-Posteriori funding commitment and additional commercialization subtask. More information may be needed.*

Description

This topic area supports and aligns with the Administration priorities as shown through incentives and investments under the Inflation Reduction Act and the Bipartisan Infrastructure Law. The Bipartisan Infrastructure Law invests \$7.5 billion in EV charging and \$10 billion in clean transportation. President Biden is committed to building out a convenient, reliable, and user-friendly national network of 500,000 EV chargers by 2030. This is also supported by the National Electric Vehicle Infrastructure program (NEVI), a \$5 billion initiative to create a coast-to-coast network of electric vehicle chargers focused on major highways. The Joint Office of DOE and Department of Transportation (DOT) supports the Federal Highway Administration (FHWA) as they introduce new requirements related to federally funded EV chargers which include references to existing standards.

Maintaining good cybersecurity practices is critically important while electric utilities decarbonize to lessen the impacts of climate change to reduce the risk of energy disruptions due to cyber-attacks. Deployment of technologies such as wind, solar, energy storage, EVs, and electric vehicle supply equipment (EVSE) will help achieve the transition to grid decarbonization but potentially introduce new vulnerabilities. Cybersecurity needs to be designed up-front prior to the installation through proper planning involving the identification of decarbonization devices, data and system needs, purposes, and specific cybersecurity considerations. Cybersecurity as an afterthought can be expensive, ineffective, and unnecessarily complicated. Additionally, in support of the National Cybersecurity Strategy³ (2023) and as identified in American National Standards Institute (ANSI)'s United States Standards Strategy⁴ (2020), DOE program offices are interested in "early collaboration with industry and standards developers to identify standards needed to meet emerging national priorities."

³ [National Cybersecurity Strategy 2023 | The White House](#)

⁴ [United States Standards Strategy \(USSS\) 2020 | ANSI](#)

The focus of this topic area is to assess and/or develop cybersecurity technical architectures, standards, and guidelines to ensure the electric utility infrastructure is protected while transitioning and operating in a decarbonized grid. Acceptable activities could also include the testing of commercially available products and system-level communications to evaluate compliance against the selected specifications. The CASP topic is divided into three subtopics below.

Subtopic 1: EVSE Standards Assessment

The focus of this subtopic area is to assess the current state of cybersecurity standards across the EVSE ecosystem (both federally funded and non-federally funded) including communication with EVs, identify opportunities to coordinate across these standards, and create new standards if applicable. Core areas of interest are cybersecurity as it relates to Charging Infrastructure and/or Grid Integration:

- Conduct a comprehensive inventory and review of standards with regard to cybersecurity applicability across the EV charging ecosystem and ascertain potential gaps with regard to cybersecurity.
- Assess or address the gaps and R&D needs identified in the body of work from established organizations that are coordinating efforts and standards, e.g. ANSI's Electric Vehicles Standards Panel (EVSP).
- Assess cybersecurity requirements in the initial design phases of equipment and systems throughout the EV charging ecosystem. Identify gaps and provide recommendations to serve as a model and establish a framework for future codes and standards development to advance "Secure-by-Design" practices.
- Assess the need and requirements for cybersecurity as part of power system interconnection standards. Identify gaps and provide recommendations for cybersecurity codes and standards development for power system interconnection.
- The awardee in this subtopic must coordinate with the awardee for Subtopic Two on DERs to ensure proper coordination.

Subtopic 2: DER Standards Assessment

The focus of this subtopic area is to assess the current state of cybersecurity standards across DER systems and identify opportunities to coordinate across these standards. This would include the following:

- Perform a preliminary assessment of existing cybersecurity standards as they apply across a range of DERs including building loads, solar, wind, storage, electric vehicles, hydrogen fuel cells, etc.
- Engage industry and other stakeholders to determine ways to coordinate these standards to limit any security gaps that may occur when not considering these technologies working together holistically with other technologies on the grid; and
- Based on the findings above, develop recommendations to DOE and appropriate standards organizations as to developing a path forward toward developing stronger, more holistic DER standards.

- The awardee in this subtopic must coordinate with the awardee for Subtopic One on EVSE's to ensure proper coordination.

Subtopic 3: Communications Architecture Assessment

The focus of this subtopic area is to assess the current and possible future state of communications architecture linking entities across the grid edge, distribution systems, and other control systems, with particular emphasis on:

- Developing scenarios with increased penetration of DERs and inverter-based resources.
- Defining grid communications requirements under such scenarios.
- Identifying cybersecurity implications of increased communications traffic among a wider variety of nodes and devices under these scenarios.
- Assessing whether current state of communications technologies, practices, and standards facilitates a future grid communications architecture that addresses anticipated functional and non-functional requirements, with a focus on cybersecurity.

For the any of the three CASP subtopics above, specific roles for the labs may include:

- Recommendations for pre-standardization research and development.
- Recommendations for Interoperability testing and data collection.
- Informing harmonization of component and system standards for interoperability and control of energy flows.
- Specific tasks will include:
 - **Stakeholder Engagement**, e.g. through meetings and workshops with stakeholders from utilities, government agencies, OEMs, and appropriate industries) to inform hardware/software designs concurrent with harmonization of standards;
 - **Impact Analysis** on the potential impact of various standards harmonization on the grid and for addressing decarbonization goals, federal, state, local, tribal, and territorial (SLTT) goals and coordination, and EJ40 priorities;
 - **Gap Analysis** including identification of barriers for adoption and recommendation of expanded cybersecurity related national laboratory resources for standards testing and integration.
 - **Recommendations** for actions to address the gaps and conflicting standards. Recommend harmonization of conflicting standards and a plan for implementation with Standards Development Organizations (SDOs) such as IEEE, IEC/ISO, and the Society of Automotive Engineers (SAE). Work with the SDOs to develop interoperable harmonized **cyber-physical** standards across energy sectors.

The work funded under this topic are expected to deliver high-impact results for advancing national grid-modernization priorities, including associated support of several DOE efforts such as programmatic or federal cybersecurity Research and Development Strategic Plans and Roadmaps.

Topic Area 3: Quantum Facilities for Applied Computing, Sensing, and Security (qFACSS)

*Supporting Offices: FECM, OE, CESER, OTT**

	Year 1/Phase 1	Year 2/Phase 2	Year 3/Phase 3
TOTAL	\$1,250,000	\$1,250,000	\$1,250,000

**Funding total may increase depending on A-Posteriori funding commitment and additional commercialization subtask. More information may be needed.*

Description

The electric sector is undergoing rapid changes, growing in complexity, and continues to be extremely vulnerable to cyber-attacks, physical incidents, and existential threats. Last year, President Biden signed into law H.R.7535, the Quantum Computing Cybersecurity Preparedness Act,⁵ which encourages federal agencies to prepare for a quantum computing threat that could break today's encryption keys. Adding to the complexity, new business models are emerging as larger portions of the economy, such as transportation, are electrified and intermittent resources and new energy storage solutions are developed and incorporated into the electric grid. Quantum Information Science (QIS) however does not only serve as a threat, but can also play a part in addressing both the grid's vulnerabilities and the grid's increasing complexity as the grid evolves to meet changing requirements and goals in the energy sector.

This qFACSS Topic Area will explore the following areas:

1. Quantum computing for optimization and contingency analysis;
2. Quantum key distribution (QKD) and post quantum cryptography (PQC) for grid cybersecurity; and
3. Quantum sensing for grid timing and synchronization with DERs (redundancy, GPS synchronization, or GPS replacement), grid anomaly detection, positioning, navigation, and timing for mobile storage (EVs with vehicle-to-everything capability), CO₂ management (e.g. pipeline or generation plant leakage detection, hydrogen leakage detection, and CO₂ sequestration and CO₂ storage), and geothermal detection/imaging.

This Topic Area will involve a lab data call to inventory currently developed QIS technologies at the labs that could be leveraged for the grid as outlined above and described in more detail below.

In parallel, This Topic Area will facilitate a Request for Information (RFI), open to both industry and lab input, to gain a holistic understanding of the landscape of QIS technologies qualified will help inform ongoing partnerships and future RDD&D funding opportunities as well as this Lab Call Topic Area if timely. Meanwhile, relevant and discrete projects under the DOE V2X MO⁶

⁵ [H.R.7535 – Quantum Computing Cybersecurity Preparedness Act | U.S. Congress](#)

⁶ [Vehicle-to-Everything \(V2X\) Memorandum of Understanding \(MOU\) | U.S. Department of Energy](#)

and other public private partnerships/collaborations could be supported and continue to be refined over time.

To the extent possible, the QIS effort also seeks to lay the foundation for a future quantum user facilities for DOE applied programs to help commercial adoption of quantum technologies for the grid and EV integration. This could be built upon and leverage lessons learned by the QIS centers funded by Office of Science.

- **Facility for Computing** (computing will be accessible via the cloud to all the labs and approved projects), **facility for security on grid and EVs**, maybe a third **facility for quantum sensing integration**, otherwise integrate quantum sensing into the other two facilities.
- These facilities will explore how to leverage existing hardware to maximize evaluation of as many types of quantum computers/systems as possible (e.g. superconducting qubits, trapped ions, neutral atoms, cold atoms, etc.).

Additional funding may be provided at a future date to further support quantum user facilities for DOE applied programs and for technology transfer/commercialization of QIS technologies.

Specific qFACSS Topic Area Lab Call tasks will include:

- **Lab data call** to inventory currently QIS technologies at the labs that could be used for the grid or DER (including bidirectional EVs and EVSE), or could be repurpose for the grid or DER (including bidirectional EVs and EVSE);
- **Stakeholder Engagement**, e.g. through meetings and workshops with stakeholders from utilities, quantum industry, national labs, academia, OEMs, and DER industries) to inform relevant/high value use cases as well as hardware/software designs (Note, this work will not inform quantum computing design, but rather identify which existing quantum computers can be utilized for a given use case (e.g. quantum annealing vs noisy intermediate scale quantum computers);
- **Hardware/Software Identification and Design** of quantum computing, quantum sensing, and quantum communications/security solutions to deliver grid optimization, resilience and security based on high value use cases. Specific QIS technologies will be identified (leveraging current technologies, but readily adaptable to next generation designs incorporating expected technology advances), and hardware design will be limited to modifications for application purposes such as delivery and implementation onto the grid. New algorithm development to leverage QIS technologies and integrate them to the extent possible will be included;
- **QIS Applied User Facility - Hardware/Software Implementation**, including component modification/assembly and code development relevant to the grid as well as evaluation (leveraging both physical and virtual testing capabilities) of components, interfaces, and

integrated systems. This task will begin to provide the foundation for a potential future applied user facility for QIS technologies to support the energy grid; and

- **Gap Analysis** based on outcomes from the lab call and hardware/software development, including identification of barriers for adoption in grid modernization and opportunities afforded by implementation of hardware and software advances; and recommendation of expanded applied QIS work and related national laboratory resources.

The following subsections provide additional background on QIS technology areas and describe the subtopic areas for qFACSS. RDD&D proposals can focus on one or more QIS technology areas, and integration across one or more QIS technology areas is highly encouraged to provide a holistic quantum system solution for the energy grid. This will begin to lay the framework for demonstrating and integrating across multiple QIS technologies and the energy grid. For example, quantum sensors could be demonstrated to connect with a quantum network to provide resilience to the grid, or quantum computers can be demonstrated to connect to the quantum network. Multiple permutations of two or more QIS technologies can be demonstrated and encouraged.

This qFACSS Topic Area may serve as early seed funding for a future QIS applied user facility to demonstrate how these technologies can provide optimization, resilience, and security for the energy grid. Coordination and collaboration with industry, utilities, state and local governments, and the private sector stakeholders is also highly encouraged to leverage additional resources, expertise, and commercially available QIS technologies (from the labs, government, academia, or industry) that could be repurposed or demonstrated on the energy grid.

Subtopic 1: Quantum computing for optimizing resilience, reliability operations, and planning
For example, applications of quantum computing to optimization, machine learning, and simulation may impact all segments of the electric sector using near-term quantum computers such as quantum annealers and noisy intermediate scale quantum computers (NISQ). This includes load modeling and load management for energy market optimization, as well as detection and analysis of faults or outages. Quantum annealers and NISQ computers could be used to address use cases where classical computing has reached limits or where there is an energy advantage to using quantum over classical computing where all else is equal.

GMI, via the National Labs, could begin with three key use cases for quantum computing in the electric sector:

- Fault prediction – Using quantum annealing, quantum neural networks, and quantum generative adversarial networks to predict when failures could occur in the energy grid and fix them prior to incident.
- Energy market optimization – Unit commitment, a combinatorial optimization problem that quantum computers are capable of solving, is used to minimize costs while still meeting demand and is an important calculation for grid operators, energy traders, and consumers. V2G would fit here.

- Integrated planning and optimization for reliable and resilient grid – Using continuous variable optimization on quantum computers to balance distributed generation, future energy sources, and placement of equipment to increase grid resilience. V2G would fit here as well. There is also interest in managing large variables of integrated systems (e.g. aggregation of V2G, home thermostats, or hot water heaters) that could be managed by virtual power plants (VPPs).

Subtopic 2: Quantum for cybersecurity and resilience

Quantum Random Number Generators (QRNG), Quantum key distribution (QKD) and post quantum cryptography (PQC) for grid cybersecurity

Cybersecurity using QRNG or QKD and PQC combined will be evaluated and demonstrated for communications between the vehicle and charger as well as the charger and beyond (e.g. to the building, microgrid, or electric grid). DOE will also provide cybersecurity technical assistance and technology transfer demonstration where possible, such as quantum key distribution and post quantum cryptography. These approaches and technologies are needed to help modernize the grid as we integrate energy and transportation to work together symbiotically and maintain grid resilience.

Existing microgrid systems depend on a classical key system that may be vulnerable to cyber-attacks. Novel methods for controlling the grid are required to accommodate renewable and distributed energy resources whose availability can fluctuate in very short time scales.

Transmission of data between different control centers needs to be secure and offer very low latency. The simultaneous requirements of both strong and fast authentication mechanism are difficult to achieve through standard cryptographic techniques. QRNG or QKD can be used to achieve secure communication and provides a means of detecting and defeating an adversary who tries to intercept or attack the communications.

Quantum sensing for grid cybersecurity and resilience

Classical sensing platforms are rapidly advancing; however, quantum sensing technologies can push their performance beyond the classical sensor systems. For example, a quantum-based photon detector can detect a wider range of light wavelengths compared to classical detectors with better performance. Additionally, quantum sensors can detect quantities at much lower values compared to classical counterparts, and this phenomenon leads to quicker and better responses for safety in harsh environments (e.g. in a nuclear reactor, where quantum sensors are used for identification of isotopes).

Quantum sensing applications currently include atomic clocks, navigation systems, non-destructive analysis, and electric and magnetic measurement devices. Additional devices include measurement of temperature, stress, and strain which could be applied to the energy infrastructure specifically to overhead power lines, towers, and transformers. Another advantage of quantum sensors is that they provide an unprecedented combination of range, resolution, and sensitivity which enhances performance, for example in the early detection of equipment failure. The use of quantum sensors in smart buildings and smart grids could

support VPP capabilities to improve energy optimization applications as well as additional security by sensing the slightest anomalies on the system.

Quantum sensing technologies can be used for cybersecurity and resilience by providing more accurate and precise measurements and information to protect and support the grid, as well as DER assets such as bidirectional EVs. There is an array of quantum sensing technologies available and under development addressing a variety of use cases. Energy specific applications to support cybersecurity and resilience could include quantum sensors for position, navigation, timing (PNT). For example, this includes electric grid timing applications (to create redundancy, GPS synchronization, or GPS replacement), and secure positioning, navigation and timing for the DER and mobile storage (EVs with V2X). Quantum sensors could also provide grid anomaly detection for cybersecurity and resilience.

This subtopic may leverage the DOE V2X MOU⁷ to help facilitate real world projects conducted by the MOU participants to evaluate and demonstrate novel cybersecurity approaches and technologies under a variety of use cases and scenarios that include QIS. The projects will include use cases for vehicle-to-grid, vehicle-to-building, and vehicle-to-load capabilities using light-, medium-, and heavy-duty vehicles.

GMI may also leverage collaborations with other federal agencies and industry to evaluate satellite to ground and satellite to satellite communications. Satellite to ground connection will be established with a grid operator to demonstrate secure grid communications using QRNG or QKD and PQC for cybersecurity as well as quantum sensing. Terrestrial testing of components and systems using free space would likely occur first.

Performance Targets

Number of Labs: Multiple

Expected outcomes:

- A library of quantum algorithms that could benefit the energy sector and demonstrated applications;
- One or more quantum sensing demonstrations on the energy grid;
- Multiple or more quantum security technology demonstrations on the grid; and
- The foundation for one or more quantum user facilities for energy applied programs, benchmarks and efficacy of quantum algorithms for energy sector, quantum sensing and quantum security technology demonstrations and interoperability for energy sector use cases.

Engagement Targets:

- Phases I/II – Cross-sectoral engagement with utilities, quantum industry, academia, labs, OEMs, including through successful workshops and reports, landscape assessment of

⁷ [Vehicle-to-Everything \(V2X\) Memorandum of Understanding \(MOU\) | U.S. Department of Energy](#)

QIS technologies and key challenges, and establishment of working groups (specifics to be determined during project negotiations);

- Phases I/II – identify hardware and develop software for QIS integration (specifics to be determined during project negotiations);
- Phase II – adapt/modify hardware where appropriate to enable grid integration/implementation; and
- Phase III – Gap analysis on barriers and opportunities to inform effective pathways forward. Gap analysis at a minimum, will be tied to one or two targets specified to quantum computer to communications linked or communications to sensing, and provide a timeline for such gaps to be resolved with appropriate resources.

Technical Targets:

- Develop an inventory of DOE Lab QIS technologies (to be integrated into DOE's Lab Partnering Service⁸);
- Report benchmarks and metrics for select use cases for quantum sensing, quantum computing and quantum communications/security;
- Create foundations for a user facility at one or two labs that includes a network for integration with one or more utilities;
- Develop hardware limited with emphasis on integration demonstrations with the energy grid. Identify/develop hardware integration tools, e.g. adapter for connecting quantum communications and quantum computers:
 - Where hardware development is not feasible, determine what designs can be developed, software could be developed, what can help facilitate a simulated use case (not really deployed but will give us ideas on the design of the system and system benefits) that connects quantum networks and computers and sensors, collecting data from power grid network and sending it back to the grid;
- Develop software and algorithms for grid optimization, resilience, and security; and
- Perform a gap analysis tied to one or two targets specified, such as a quantum computer to a quantum communications linked system or network or quantum communications to quantum sensing, etc. Create a timeline for gaps to be resolved to achieve real-time deployment.

⁸ [Lab Partnering Service™ | U.S. Department of Energy](#)

Topic Area 4: Equitable System Operation and Planning (ESOP)

Supporting Offices: ED, GDO, OE, FECM, EERE, CESER

	Year 1/Phase 1	Year 2/Phase 2	Year 3/Phase 3
TOTAL	\$1,467,000	\$1,267,000	\$1,267,000

Note: Subtopic reapportionment is dependent on proposal responses from the National Labs.

Description

Energy Justice (EJ) has been identified as a high priority that requires additional work to address within grid modernization efforts. Formalizing energy and environmental justice objectives are gaps in today's markets, policies, and standards for grid planning and operation. EJ refers to the goal of achieving equity in both the social and economic participation in the energy system, while also remediating social, economic, and health burdens on those frontline communities historically harmed by the energy system. Energy justice explicitly centers the concerns of marginalized communities and aims to make energy more accessible, affordable, clean, and democratically managed for all communities. There are opportunities to address systemic burdens on disadvantaged communities (DACs) historically harmed by the energy system and provide benefits to DACs through grid planning. Grid planning can center the needs of DACs to relieve pollution from fossil fuel generation, impacts of infrastructure siting, and increase resiliency and energy security in DACs.

Subtopic 1: Methods, Tools, and Datasets to Enable EJ Planning and Assessment

This subtopic further calls for development of methods, tools, and datasets that can be used to perform EJ planning and assessment for grid applications. In addition, this subtopic calls for new market design proposals and business models that incentivize energy equity as an explicit objective. Proposals should leverage existing metrics, methods, tools, and datasets identified to the extent possible (for instance, examples from state PUCs). These deliverables would be targeted to be completed by the end of Year 1 of this Lab Call, and follow-on deliverables would be developed at the direction of GMI and subject to appropriations.

An aim is to improve electricity affordability, reduce energy poverty, and reduce pollution burdens. One example application is capacity building or demonstration projects in DACs for EV charging stations or grid access more broadly. Can bidirectional EVs become a resilience asset in these communities and provide ride-hailing jobs at the same time? Where can grid infrastructure be improved or built to increase capacity for EV charging stations or to increase reliable grid access for grid-edge communities or to potentially connect remote communities to the grid? What research can help support the adoption of non-traditional metrics and data tools to identify areas of underinvestment or measure grid reliability and performance at a more granular level? Other examples include clean energy transition of coal-rich communities and locational impact of renewable generation on local communities, e.g. those in the Northwest. There also exists inequitable impact of extreme weather and outages on grid resilience for DACs. Some studies have shown that areas with a high share of minority population were more than four times as likely to suffer a blackout than predominantly white

areas. What is the outage frequency and duration in DACs compared to areas without DACs? Are there new methods for collecting outage data that could be used or should be developed to obtain more granular outage data? Finally, this subtopic should support research to explore localized pollution impacts and negative externalities that result from regional energy policies and market designs.

Note: The Grid Deployment Office will fund the piloting and demonstration of these new methods, tools, and datasets developed as part of this Subtopic.

Subtopic 2: Policies and standards for grid planning and operation considering EJ
Proposals for this subtopic should leverage the metrics, methods, tools, and datasets from Subtopic 1 work, to the extent possible. These deliverables would be targeted to be completed by the end of Year 1 of this Lab Call, and follow-on deliverables would be developed at the direction of GMI and subject to appropriations.

Equity should be considered in transmission planning and development. Metrics from Subtopic 1 should support efforts to incorporate equity as an explicit objective in relevant energy planning models and procedures. What factors do Transmission System Operators and Transmission Operators in utilities at the distribution level use to determine target areas for load shedding and for prioritizing service restoration after a blackout? Are there reliability standards and interoperability procedures with adjacent Transmission Providers that influence loadshedding, outage, and restoration decisions? Do resource sufficiency and resource adequacy policies impact unplanned outages?

Research proposals might also consider outputs relevant to Public Utility Commission policymaking. Where are utilities making improvements and why and how does that go into the planned outage schedules? Do planned outages increase the risk of unplanned outages and load shedding in DACs? How are DACs priorities in the disaster recovery and utility restoration procedures? How do we incorporate customer-centered metrics for assessing and evaluating outage frequency and duration?

Performance Targets

Number of Labs: Multiple

Expected outcomes:

- Literature review of existing studies on the two ESOP subtopics, and creation and maintenance of a repository of these studies (Word doc with links or folder with downloaded PDFs if paywalls are an issue);
- Identification of best practices where they exist and gaps where they don't exist that address the two ESOP subtopics; and
- Bring together industry and decisionmakers to develop metrics and/or methodologies to fill identified gaps (Particular interest in metrics that could be incorporated into project or proposal evaluation).

Topic Area 5: Climate Impact on Energy Resources (CIER)

Supporting Offices: OE, EERE, FECM, CESER

	Year 1/Phase 1	Year 2/Phase 2	Year 3/Phase 3
TOTAL	\$3,333,000	\$3,333,000	\$3,333,000

Number of Awards: 3-4

Award Structure: an award can be made to applications led by multiple labs. We encourage applicants to consider teaming with other organizations.

Description

While the earth has had a relatively stable environment over the last 10,000 years, our climate is changing and having an immediate impact on the way the electric power system operates. Climate change is driving divergences in both the long-term weather trajectories as well as the frequency, duration, and location of extreme weather events. Current examples include 1200-year droughts in the West, increasing prevalence of severe tropical storms and hurricanes in the Southeast, and a variety of polar vortex-like conditions.

Unfortunately, it is expected that these impacts will become more severe in the near-term (e.g., 10 year) and in the mid-term (e.g., 20-30 years). These impacts will have consequences for the generation system, the transmission and distribution systems, and load. It is critical that DOE evaluates these impacts as a power system to understand the interdependencies both within the electric power system and with other infrastructures (e.g., communication, transportation, etc.). This makes this project a perfect candidate for the Grid Modernization Laboratory Consortium (GMLC).

The Climate Impacts on Energy Resources (CIER) topic's objectives are developing the ability to create climate-adjusted future weather data, effectively manipulating and querying it, using future weather data to calibrate future load and resource potential assumptions, and piloting the use of climate-calibrated data in real world power sector analytical processes. Multiple applicants will receive awards and work in parallel to understand tradeoffs and the optimal application of different methodologies, building up know-how across the national laboratory complex and expanding our ability to help stakeholders.

Project Sequencing and Key Challenges

Year 1 – Stage 1 – Coordination, External Engagement, and Climate Scenarios
(All awardees together):

- Develop centralized coordination committee across awardees that will convene on a regular basis during all stages of the project.
- Setup a workshop to engage industry, academia, and interagency partners, could consider partnerships with other groups like EPRI's Climate READi

- Evaluate the trade-offs between macro climate scenarios and their ability to be captured by GCMs.
- Identify standard set of climate change scenarios to be evaluated in Stage 2

Year 1 – Stage 2 – Methodologies to Translate Future Climate Projects into Weather Data & Calibrate Energy Resource, Load, and Infrastructure Data

(3-4 awardees will address the following challenges individually):

- Challenge 1: Translating Climate Modeling into Future Weather Data
 - Best way to translate climate scenarios to create future weather data at different resolutions?
 - What are trade-offs at different spatial/temporal resolution? How to minimize/overcome computational limitations?
 - What are the right metrics to capture?
 - How to combine or query across datasets? How to improve the data science to slice and dice data efficiently
 - Can we identify high probability disaster zones (flooding, blizzard, wildfire – so we don't build critical infrastructure there?)
 - What format is most useful, etc.?
- Challenge 2: Using Future Weather Data to Calibrate Energy Resource and Load Data
 - How do you calibrate energy resources and load based on future weather data? How to do this in an *internally consistent way*?
 - Factors that need to be considered for calibration:
 - Wind
 - Solar
 - Hydro
 - Nuclear
 - Thermal Generators
 - Carbon Capture
 - Biomass supply
 - Load
 - Infrastructure

Year 2: Using Calibrated Climate, Weather, Energy, and Load Data to Answer Applied Research Questions

(3-4 awardees will address the following challenges individually):

- Use climate calibrated energy resource and load data to:
 - examine an **applied research question** (e.g., national-level impact);
 - Inform a **stakeholder analysis** (e.g., as a scenario in an IRP or stress testing a system against extreme events).
- Follow on efforts to improve range and quality of data, data access, data science, and minimize computational burden.

Year 3: Expanded Use of Calibrated Climate, Weather, Energy, and Load Data to Answer Applied Research Questions & Provide Technical Assistance

Stage 1: Develop a model of the environment in 10, 20, and 30 years that can be applied to the electric power system as a whole including generation sources, transmission, and load.

- Task 1 – Identify existing general circulation models (GCMs), conduct a multi-model comparison to understand how different formulations/inputs impact the results as well as the range of uncertainty. Ultimately, select a single GCM, inputs, and scenarios to use for future activities.
- Task 2 – Develop framework to translate climate model outputs into high spatial/temporal resolution weather data. Validate the process using historical data.

Stage 2: Based on Stage 1, derive impacts across the range of technologies including (again) generation (all the different types), transmission and distribution, and load.

- Task 3 – Use future high spatial/temporal weather data to calibrate future demand (electricity and fuel) trajectories that also account for major trends like electrification and energy efficiency improvements
- Task 4 – Use future high spatial/temporal weather data to calibrate generation resource potential, especially weather-dependent renewable resources.
- Task 5 – Develop framework to couple GCM data with hydrological models and downscale results with the same high spatial/temporal resolution. Use future weather data to calibrate hydro resource availability and impact on thermal generator outages.
- Task 6 – After “average” future weather scenarios are modeled, develop a range of potential future “extreme” weather scenarios.

Stage 3: Based on the outcomes in stage 1&2, model outcomes on the power system in 10, 20, and 30 years. Insights from this effort should help inform how DOE Offices plan their R&D portfolios in the future and stakeholder decision processes (e.g., IRPs, resilience investments, etc.).

- Task 7 – Conduct a geospatial analysis of current and potential future infrastructure placement given expected climate change impacts, e.g., don’t build infrastructure or generators in locations likely to be impacted by floods, hurricanes, or wildfires.
- Task 8 – Identify the impacts of potential future weather scenarios (both average and extreme) on the generation and infrastructure mix, grid operation, cost, reliability, and resilience.
- Task 9 – Use the data, capabilities, and results from the proceeding efforts to provide technical assistance to states, utilities, grid operators, etc. to enhance their capacity to plan and make beneficial investment decisions that can mitigate negative impacts of climate change and more frequent extreme weather.

Performance Targets

DOE expects to make up to \$10M of Federal funding available in this GMI Lab Call over three years, subject to the availability of appropriated funds. To increase stakeholder engagement, all proposed projects will reflect non-laboratory partner participation equivalent to at least 20% of the total allowable project costs. In addition, providing federal funding for team members (industry, academia) and development of consortia is permissible as well. The funding breakdown for these efforts is below:

All proposals must have an industry partner (e.g., investor owned utility, electric cooperative, public power, regional planning entity, ISO/RTO, etc.). An integrated, multifaceted team approach including cooperation and active collaboration with members of utilities, product and service suppliers, end users, state and municipal governments, Independent System Operators/Regional Transmission Organizations (ISOs/RTOs), universities, and others is strongly encouraged.

Proposal Review Criteria

Proposals will be evaluated using the following criteria. All sub-criteria are of equal weight. Please see OTSP guidance for federally funded research⁹ and note if proposals anticipate exemptions.

Criterion 1: Technical Merit, Innovation, and Impact (50%)

Technical Merit and Innovation

1. Extent to which the applicant clearly, specifically, and convincingly describes how the proposed technology or process is innovative and will advance the state-of-the-art;
2. Degree to which the current state of the technology and the proposed advancement are clearly described; and
3. Sufficiency of technical detail in the application to assess whether the proposed work is scientifically meritorious and revolutionary, including relevant data, calculations, and discussion of prior work in the literature with analyses that support the viability of the proposed work.

Impact of Technology Advancement

- Potential impact of demonstrated success within the first 18 months to two years of project initiation;
- Clarity of the description of how the project supports the topic area objectives and target specifications and metrics;
- Potential impact of the project on the grid including near-term and long-term benefits and risks;
- Extent to which the research investment helps the national laboratory complex build appropriate, coordinated core expertise and capabilities for the future;
- Degree to which the project incorporates outputs from the activities of the FY16 GMI Lab Call to validate foundational principles; e.g., architecture, interoperability, integration testing, valuation, cybersecurity, etc.; and
- Degree of impact across the five applied Offices including FE, OE, EERE, NE, and CESER.

Criterion 2: Research Approach and Adoption (30%)

Research Approach and Work Plan

- Degree to which the approach and critical path have been clearly described and thoughtfully considered; and
- Degree to which the task descriptions are clear, detailed, timely, and reasonable, resulting in a high likelihood that the proposed Work Plan will succeed in meeting the project goals.

⁹ [Guidance to Make Federally Funded Research Freely Available Without Delay | Office of Science and Technology Policy, The White House](#)

Identification of Risks

- Clarity of the discussion and demonstrated understanding of the key technical and institutional risk areas involved in the proposed work, and the quality of the mitigation strategies to address them.

Baseline, Metrics, and Deliverables

- Degree of clarity in the definition of the baseline, metrics, and milestones; and
- Relative to a clearly defined experimental baseline, the strength of the quantifiable metrics, milestones, and a mid-point deliverables defined in the proposal, such that meaningful interim progress will be made.

Transformation Plan

- Clarity of adoption potential for proposed technology along with known or perceived barriers to transformation, including a mitigation plan.

Criterion 3: Team and Resources (20%)

- Clarity of the description of the Principal Investigator(s) (PIs) and the proposed team to successfully address all aspects of the proposed work;
- Appropriateness of qualifications, relevant expertise, and time commitment of the individuals on the team;
- Sufficiency of facilities to support the proposed work;
- Ability of the proposed team to facilitate and expedite development and deployment of the proposed technologies;
- Level of substantive participation by non-laboratory; i.e., industry, academia, consortia; project participants as evidenced by non-laboratory leadership roles within the project, type and amount of non-laboratory cost share, letter(s) of commitment from non-laboratory partners, and distribution of the critical path activities beyond the PI and the PI's institution within the Work Plan; and
- Reasonableness of budget and spend plan for proposed project and objectives.

Timeline and Process for Foundational Lab Call

The following is a timeline for the Foundational Lab Call review and selection process:

Lab Call Milestone	Timeline (2023)
FY23 Foundational Lab Call Released	April 25
Informational Webinar	(21 days) May 15
Concepts Submission Deadline	(40 days) June 5
Concept Presentations	(9 days) June 14
Full Proposal Submission Deadline – by invitation only	(40 days) July 24
Full Proposal Presentations	(10 days) August 2
Selection Announcement by DOE	(13 days) August 15
Funding Released to GMLC	August 15

Concept Specifications

Applicants will submit project concepts as a Microsoft PowerPoint presentation to DOE for evaluation. In addition to the concept presentation, the Applicant must submit a one-slide summary identifying the lead organization, the PI(s), the project title, the objectives of the project, a brief project description, the potential impact of the project, and major team participants. Submissions must be emailed to Kerry.Worthington@ee.doe.gov; Kerry Worthington is a joint representative to the DOE Offices involved in GMI.

Applicants will present their concept presentations to DOE (**virtually**). Concept presentations will be 30 minutes, which includes a 15-minute presentation and a 15-minute question and answer session. Based on evaluation of the concepts against the technical criteria, DOE will invite a subset of applicants to submit full proposals. A PowerPoint template will be provided.

Full Proposal Specifications

Each invited applicant will submit its full proposal as a Microsoft PowerPoint presentation to DOE for evaluation. In addition to the full proposal presentation, the applicant must submit a one-page summary for dissemination to the public if an award is made. During this phase of the lab call, the invited applicant has the option to submit a supplemental materials document not to exceed 10 pages in length. If a supplemental materials document is submitted, it may not be a mere restatement of the PowerPoint contents. The full proposal must build upon the previously presented concept and include a plan of engagement with team members, team member commitments, key deliverables, and final financial breakdown across all team members. Submissions must be emailed to Kerry.Worthington@ee.doe.gov; Kerry Worthington is a joint representative to the DOE Offices.

The invited applicant will present its full proposal presentation to DOE. In-person participation in Washington, D.C., is encouraged. Given the crosscutting nature of this lab call, each project will need to fit within the broader collaborative vision of its relevant topic area. The full proposal presentations will be 40 minutes which includes a 20-minute presentation, a 5-minute discussion on GMLC coordination related to that particular project, and a 15-minute question and answer session. Based on evaluation of the full proposals against the technical criteria, DOE will select final projects.