

Environmental Management - Grand Junction Office



Final Remedial Action Plan and Site Design for Stabilization of Moab Title I Uranium Mill Tailings At the Crescent Junction, Utah, Disposal Site

Attachment 3: Ground Water Hydrology

February 2008



U.S. Department
of Energy

Office of Environmental Management

**Remedial Action Plan and Site Design
for Stabilization of Moab Title I Uranium Mill Tailings
at the Crescent Junction, Utah, Disposal Site**

Attachment 3: Ground Water Hydrology

Work performed under DOE Contract No. DE-AC01-02GJ79491
for the U.S. Department of Energy Office of Environmental Management.
Approved for public release; distribution is unlimited.

Calculation Cross-Reference Guide

Location	Calculation Number	Calculation Title
Attachment 1: Draf RAP Disposal Cell Design Specifications		
Appendix A	MOA-02-08-2006-5-19-01	Freeze/Thaw Layer Design
Appendix B	MOA-02-08-2006-5-13-01	Radon Barrier Design Remedial Action Plan
Appendix C	MOA-02-05-2007-5-17-02	Slope Stability of Crescent Junction Disposal Cell
Appendix D	MOA-02-05-2007-3-16-01	Settlement, Cracking, and Liquefaction Analysis
Appendix E	MOA-02-09-2005-2-08-01	Site Drainage – Hydrology Parameters
Appendix F	MOA-02-06-2006-5-08-00	Crescent Junction Site Hydrology Report
Appendix G	MOA-02-04-2007-5-25-02	Diversion Channel Design, North Side Disposal Cell
Appendix H	MOA-02-08-2006-6-01-00	Erosional Protection of Disposal Cell Cover
Appendix I	MOA-01-06-2006-5-02-01	Volume Calculation for the Moab Tailings Pile
Appendix J	MOA-02-08-2006-5-03-00	Weight/Volume Calculation for the Moab Tailings Pile
Appendix K	MOA-01-08-2006-5-14-00	Average Radium-226 Concentrations for the Moab Tailings Pile
Attachment 2: Geology		
Appendix A	MOA-02-04-2007-1-05-01	Site and Regional Geology – Results of Literature Research
Appendix B	MOA-02-04-2007-1-01-01	Surficial and Bedrock Geology of the Crescent Junction Disposal Site
Appendix C	MOA-02-04-2007-1-06-01	Site and Regional Geomorphology – Results of Literature Research
Appendix D	MOA-02-04-2007-1-07-01	Site and Regional Geomorphology – Results of Site Investigations
Appendix E	MOA-02-04-2007-1-08-01	Site and Regional Seismicity – Results of Literature Research
Appendix F	MOA-02-04-2007-1-09-02	Site and Regional Seismicity – Results of Maximum Credible Earthquake Estimation and Peak Horizontal Acceleration
Appendix G	MOA-02-04-2007-1-02-01	Photogeologic Interpretation
Attachment 3: Ground Water Hydrology		
Appendix A	MOA-02-02-2006-2-07-00	Saturated Hydraulic Conductivity Determination of Weathered Mancos Shale
Appendix B	MOA-02-03-2006-2-10-00	Field Permeability “Bail” Testing
Appendix C	MOA-02-03-2006-2-06-00	Field Permeability “Packer” Testing
Appendix D	MOA-02-04-2006-2-03-00	Hydrologic Characterization – Ground Water Pumping Records
Appendix E	MOA-02-05-2006-2-13-00	Hydrologic Characterization – Vertical Travel Time to Uppermost (Dakota) Aquifer
Appendix F	MOA-02-02-2007-3-01-00	Geochemical Characterization – Radiocarbon Age Determinations for Ground Water Samples Obtained From Wells 0203 and 0208
Appendix G	MOA-02-06-2007-2-14-00	Hydrologic Characterization – Lateral Spreading of Leachate
Attachment 4: Water Resources Protection		
Appendix A	MOA-02-06-2006-5-24-00	Material Placement in the Disposal Cell
Appendix B	MOA-02-06-2006-3-05-00	Geochemical Attenuation and Performance Assessment Modeling
Attachment 5: Field and Laboratory Results, Volume I		
Appendix A	MOA-02-03-2006-1-03-00	Corehole Logs for the Crescent Junction Site
Appendix B	MOA-02-03-2006-1-11-00	Borehole Logs for the Crescent Junction Site
Appendix C	MOA-02-03-2006-1-04-00	Geophysical Logs for the Crescent Junction Site
Appendix D	MOA-02-03-2006-1-10-00	Test Pit Logs for the Crescent Junction Site
Appendix E	MOA-02-03-2006-4-01-00	Geotechnical Properties of Native Materials
Appendix F	MOA-01-06-2006-5-22-00	Cone Penetration Tests for the Moab Processing Site
Appendix G	MOA-02-05-2006-4-07-00	Seismic Rippability Investigation for the Crescent Junction Site
Appendix H	MOA-02-03-2007-3-04-01	Background Ground Water Quality for the Crescent Junction Site
Appendix I	MOA-01-08-2006-4-08-00	Boring and Test Pit Logs for the Moab Processing Site
Appendix J	MOA-01-08-2006-4-09-01	Geotechnical Laboratory Testing Results for the Moab Processing Site
Appendix K	MOA-02-04-2007-4-03-01	Supplemental Geotechnical Properties of Native Materials
Attachment 5: Field and Laboratory Results, Volume II		
Appendix L	MOA-02-08-2006-1-06-00	Compilation of Geologic and Geophysical Logs
Appendix M	N/A	Radiological Assessment for Non-Pile Areas of the Moab Project Site
Appendix N	MOA-02-05-2007-4-04-00	Supplemental Geotechnical Properties of Tailings Materials from the Moab Processing Site

Attachment 3

Table of Contents

Appendix A	Saturated Hydraulic Conductivity Determination of Weathered Mancos Shale
Appendix B	Field Permeability “Bail” Testing
Appendix C	Field Permeability “Packer” Testing
Appendix D	Hydrologic Characterization – Ground Water Pumping Records
Appendix E	Hydrologic Characterization – Vertical Travel Time to Uppermost (Dakota) Aquifer
Appendix F	Geochemical Characterization – Radiocarbon Age Determinations for Ground Water Samples Obtained From Wells 0203 and 0208
Appendix G	Hydrologic Characterization – Lateral Spreading of Leachate

U.S. Department of Energy—Grand Junction, Colorado

Calculation Cover Sheet

Calc. No.: MOA-02-02-2006-2-07-00 Discipline: Geotechnical/Hydrological No. of Sheets: 10
 Doc. No.: X0136700

Location: Attachment 3, Appendix A

Project: Moab UMTRA Project

Site: Crescent Junction Disposal Site

Feature: Saturated Hydraulic Conductivity Determination of Weathered Mancos Shale

Sources of Data:

See Appendix A

Sources of Formulae and References:

Bouwer, H. 1966. "Rapid field measurement of air-entry value and hydraulic conductivity of soils as significant parameters in flow systems analysis," in *Water Resources Research*, 2(4), pp. 729–738.

DOE (U.S. Department of Energy), 1994. "In Situ Testing to Determine Field-Saturated Hydraulic Conductivity of UMTRA Project Disposal Cell Covers, Liners, and Foundation Areas Special Study," DOE/AL/62350-100, prepared by Jacobs Engineering Group, Inc., Albuquerque, New Mexico, February.

Youngs, E.G., P.B. Leeds-Harrison, and D.E. Elrick, 1995. "The Hydraulic Conductivity of Low Permeability Wet Soils Used as Landfill Lining and Capping Material: Analysis of Pressure Infiltrometer Measurements," *Soil Technology*, Vol. 8, pp. 153–160.

Waugh, W.J., S.J. Morrison, G.M. Smith, M. Kautsky, T.R. Bartlett, C.E. Carpenter, and C.A. Jones, 1999. *Plant Encroachment on the Burrell, Pennsylvania, Disposal Cell: Evaluation of Long-Term Performance and Risk*, GJO-99-96-TAR, Environmental Sciences Laboratory, U.S. Department of Energy, Grand Junction, Colorado.

Preliminary Calc. Final Calc. Supersedes Calc. No.

Author:	<u>Mark Kautsky</u>	<u>5-31-07</u>	Checked by:	<u>[Signature]</u>	<u>5/30/07</u>
	Name	Date		Name	Date
Approved by:	<u>[Signature]</u>	<u>5/31/07</u>		<u>[Signature]</u>	<u>31 May 07</u>
	Name	Date		Name	Date
				<u>[Signature]</u>	<u>5/31/07</u>
				Name	Date
				<u>[Signature]</u>	<u>5/31/07</u>
				Name	Date

No text for this page

Problem Statement:

Determine the saturated hydraulic conductivity of the weathered Mancos Shale (wrthd K_m) interval at the proposed Crescent Junction Disposal Site.

Method of Solution

Use Air-Entry Permeameter (AEP) testing following installation procedures and methods as discussed in the Calculation section.

Assumptions:

1. AEP testing provides realistic saturated hydraulic conductivity results for wrthd K_m located at the Crescent Junction Disposal Site.
2. Excavating a soil "pedestal" and placing the AEP permeameter ring around the pedestal accurately tests pedestal materials.
3. Hydrated sodium bentonite adequately seals the AEP test and does not adversely affect results.

Computer Source:

Microsoft Excel

Calculation:

The AEP, developed by Herman Bouwer (Bouwer 1966) for determining air-entry and saturated hydraulic conductivity values for soils above the ground water table, is illustrated in Figure 1.

The AEP was initially designed to test agricultural soil; however, the device and method have been successfully extended to test air-entry and saturated hydraulic conductivity values for bedrock foundation materials. Sandstone and sandstone/siltstone bedrock materials have been tested with the AEP at the DOE Estes Gulch Disposal Site north of Rifle, Colorado (DOE 1994).

When the AEP is used to test soils, the permeameter ring is driven into the soil forming a tight seal between the soil and ring. When foundation bedrock materials are tested, a circular channel must be excavated into the bedrock, see the following Figures 2 through 6. The channel is subsequently filled with sodium bentonite to create the seal around the permeameter ring. By doing this, an assumption is made that the saturated hydraulic conductivity of the foundation materials is greater than the saturated hydraulic conductivity of the bentonite. This assumption is easily tested by comparing the computed saturated hydraulic conductivity value to 5×10^{-9} cm/sec, which is a typical saturated hydraulic conductivity value for sodium bentonite.

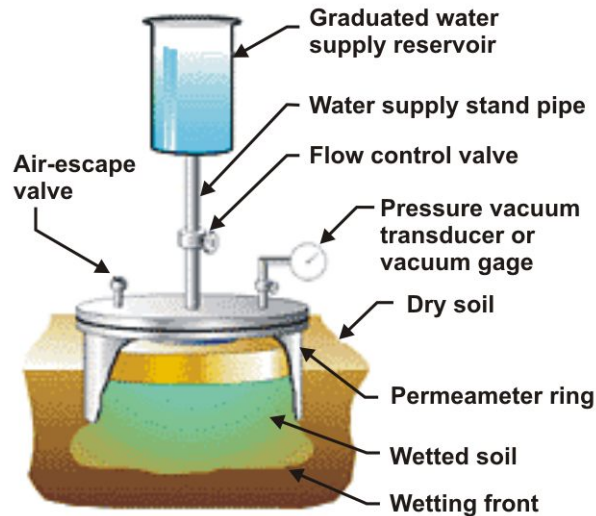

Figure 1. Air-Entry Permeameter
(ref. unknown)

The AEP consists of a 12-inch (30-centimeter)-tall sealed ring with a 12-inch (30 centimeter) inside diameter embedded approximately 6 inches (15 centimeters) into the surface. A graduated water supply is mounted to the sealed ring via a standpipe of varying lengths allowing different hydraulic heads to be applied to the soil.

Field Procedure

Installation:

1. Clear and smooth a surface excavated into the wrthd K_m approximately 2 feet by 2 feet.
2. Excavate a circular channel approximately 2 inches wide and approximately 6 inches deep into the wrthd K_m as shown in Figure 2. Diameter of the circular channel should be such that the AEP test ring can be positioned in the approximate center. Base of the channel should be smoothed to provide a level and horizontal contact for the AEP test ring as shown in Figure 3.



Figure 2. Excavating Circular Channel into Weathered Mancos Shale to Place AEP Ring

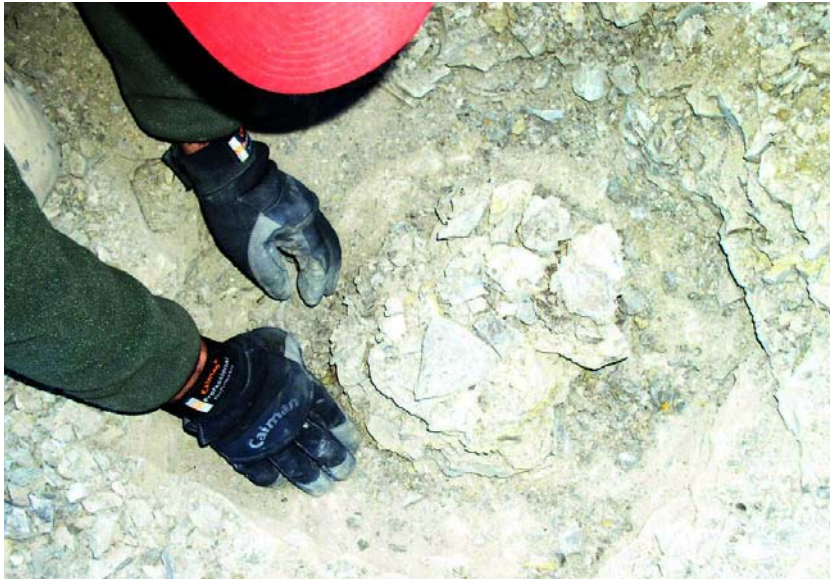

Figure 3. Smoothing and Leveling Channel Base

3. Two to three inches of powered sodium bentonite should be placed in the base of the channel as shown in Figure 4.



Figure 4. Sodium Bentonite in Bottom of Circular Channel Excavated into Weathered Mancos Shale

4. Mix water with bentonite in channel before placing ring in channel. Add more bentonite, refill channel with water and allow to hydrate bentonite for a minimum of 3 days (see Figure 5).



Figure 5. AEP Ring Placed in Channel With Bentonite Prior to Adding Water to Fully Hydrate Bentonite

5. Backfill the channel along the ring exterior with spoil as shown in Figure 6.



Figure 6. Channel Along Ring Exterior Filled with Spoils Prior to Testing

6. The ring is filled with water prior to attaching and sealing the lid and water supply cylinders.
7. The water supply is filled and flow-control and air valves are opened to allow water to flow out of the AEP setup. All air bubbles are removed from the ring to ensure complete saturation of the permeameter. Figure 7 shows an installed AEP.



Figure 7. AEP Installed in wthrd K_m – TP 0154

Testing:

1. The water supply is refilled; initial readings (listed below) are taken and recorded before the flow control valve is opened to initiate the test.
2. Water level readings are taken and recorded at specified time intervals until steady-state infiltration is achieved.
3. The flow control value is closed and a final water level (H_f) is recorded.
4. A hand held vacuum pump is attached to the vacuum gauge and valve attachment. A vacuum is applied to the AEP and the greatest vacuum pressure achievable is recorded. The highest vacuum pressure will occur immediately prior to air bubbles flow.

Analysis:

The equation to compute a saturated hydraulic conductivity (K_{sat}) value from the AEP test is (Bouwer 1966; DOE 1994):

$$K_{sat} = 2 \frac{dH}{dt} L \frac{R_r^2}{R_s^2} \left/ (H + L - \frac{1}{2} P_a) \right. \quad [1]$$

where: dH/dt (cm/sec) = change in hydraulic head with respect to time,
 L (cm) = depth of infiltration,
 R_r (cm) = radius of water supply reservoir,
 R_s (cm) = radius of soil pedestal,
 H_f (cm) = final height of water in water supply reservoir, and
 P_a (cm) = air-entry pressure (vacuum pressure + gauge height + depth of infiltration).

Three test pits, TP 0152, TP 0154, and TP 0156, were excavated to the wrthd K_m interface at the Crescent Junction Disposal Site. Two AEPs were installed in TP 0152, one AEP in TP 0154 and two AEPs in TP 0156. Bentonite failed to seal one AEP permeameter ring in each of TP 0152 and TP 0156; thus, a total of three AEP test were performed.

Copies of field data sheets and plots of hydraulic head versus time for each test are attached to this report in the Appendix. Also included are copies of hand calculations.

Results:

Table 1 presents results of the AEP tests. Shown on the table are values for air-entry (cm), dH/dt (cm/sec) and computed K_{sat} .

Table 1. AEP Results

Location	Air-Entry (cm)	dH/dt (cm/sec)	K_{sat} (cm/sec)
TP 0152	183	7.8×10^{-4}	4.4×10^{-5}
TP 0154	140	5.8×10^{-3}	1.6×10^{-4}
TP-0156	241	1.7×10^{-2}	2.6×10^{-4}

Geometric mean of all K_{sat} values = 1.2×10^{-4} cm/sec.

Discussion:

Other methods exist to compute field saturated hydraulic conductivity in fine-grained materials based on infiltration results. A method proposed by Youngs et al. (1995) has been used to validate the saturated hydraulic conductivity of compacted clay barrier layers on UMTRA disposal cells (Vaughn et al. 1999). This method assumes that the soils are initially "wet", or close to saturation. Based on the air-entry values tested, the wrthd K_m is considered sufficiently "dry" to account for soil suction, therefore the method proposed by Youngs et al. (1995) is no longer considered.

Tests were performed during the winter of December 2005 and January 2006. Upon returning to TP 0152 after installation of permeameter rings and the required 3 days for bentonite hydration was allowed to occur, the installation was frozen as shown in Figure 8.

The ice was chipped out and the diameter of the enclosed wrthd K_m inspected. The approximate upper 1 inch of soil was frozen over an approximate 6 inch diameter forming an "ice cap" on the soil pedestal. Water does not infiltrate into soils below the ice cap. Accordingly, the area receiving flow was measured to compute the flow area. The test was run, and an effective area representing the reduced flow area was used computation of K_{sat} . This consisted of computing an equivalent area and radius, R_s in equation [1] of the soil pedestal. Errors introduced by doing this are considered to be of the same order as errors introduced by excavating the circular channel and embedding the permeameter ring, so the results are still considered applicable for use in design.



Figure 8. Frozen Hydration Water in the Non-Leaking AEP Test Performed in TP 0152

Conclusion and Recommendations:

A design saturated hydraulic conductivity value of 1.2×10^{-4} cm/sec should be used for wrthd K_m material, based on AEP test results conducted December 2005 and January 2006 at the proposed Crescent Junction, Utah, Disposal Site.

The resulting geometric mean of measured in situ saturated hydraulic conductivity values for the weathered Mancos Shale at the proposed disposal cell site, should be considered a first-order approximation, due to of the small sample size. Although the 12-inch-diameter size of the permeameter ring is large enough to measure preferential flow around shale fragments, as illustrated in Figure 4, statistical confidence in the mean is low. Increasing the number of data points will provide more confidence of the mean, however given that the range of tested values are within one-order of magnitude, the mean is not expected to vary significantly.

End of current text

Appendix A

Field Notes and Hand Computations for K_{sat} Determination

TP 0152 Field Data Sheets and Plots

Measured Parameters

152 w

R_{ws} (Radius of Water Supply Reservoir)
2.5 cm

H_f (Final water head reading when water flow valve is shut)
23.7 cm + 38.1 = 61.8

R_{sr} (Radius of Soil Ring)
9.5" ϕ / 2 cm = 42.1 cm / 10.9

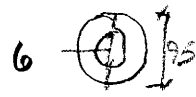

P_{min} (Gauge pressure at air entry, a negative value)
10 cm cent. bars \times 10.2 cm/cent.bar = 102 cm

G (Height of gauge above soil surface)
8.5" cm = 21.6 cm

L (Depth from soil surface to wetting front)
2" below base of ring = 26.7 cm
excess bentonite after installation

Data

$h = 15.0 \times 2.54 = 38.1$

0
0.5
1
2
4
8
15
30
45
60

Time (min)	Reservoir Reading (cm)	Head (cm)	dH (cm)	dT (s)	dH/dT (cm/s)	mean dH/dT
0	27.6					
0.5	27.4					
1	27.2					
2	27.0					
4	26.8					
8	26.5					
15	26.0					
30	25.1					
45	24.4					
60	23.7					

Soil in ring initially saturated water @ 40°C
-
test applicable

152E leaked upon removing water stayed high in hole

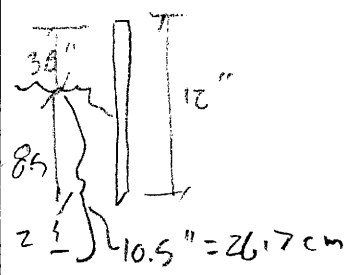

P_a (Air entry value, negative value) = $P_{min} + G + L = 102 + 21.6 + 26.7 =$

150.3 cm

$dH/dT =$ (Change in head/Change in time) for last two data points

-0.000844 cm/s

$K_{sat} = -(2 * dH/dT * L * (R_{ws}/R_{sr})^2) / (H_f + L - (0.5 * P_a))$ (cm/s) = $2.37 * 10^{-3} / 13.35$

$1.8 * 10^{-4}$ cm/s
 $= 2 * 10^{-4}$ cm/sec

$A_b = 70.88$
 $A_H = 12.57$
 $58.32 = \pi d^2 / 4$
 $d = 8.62$ in = $8.62 / 2 = 4.31$ in = 10.9 cm ✓

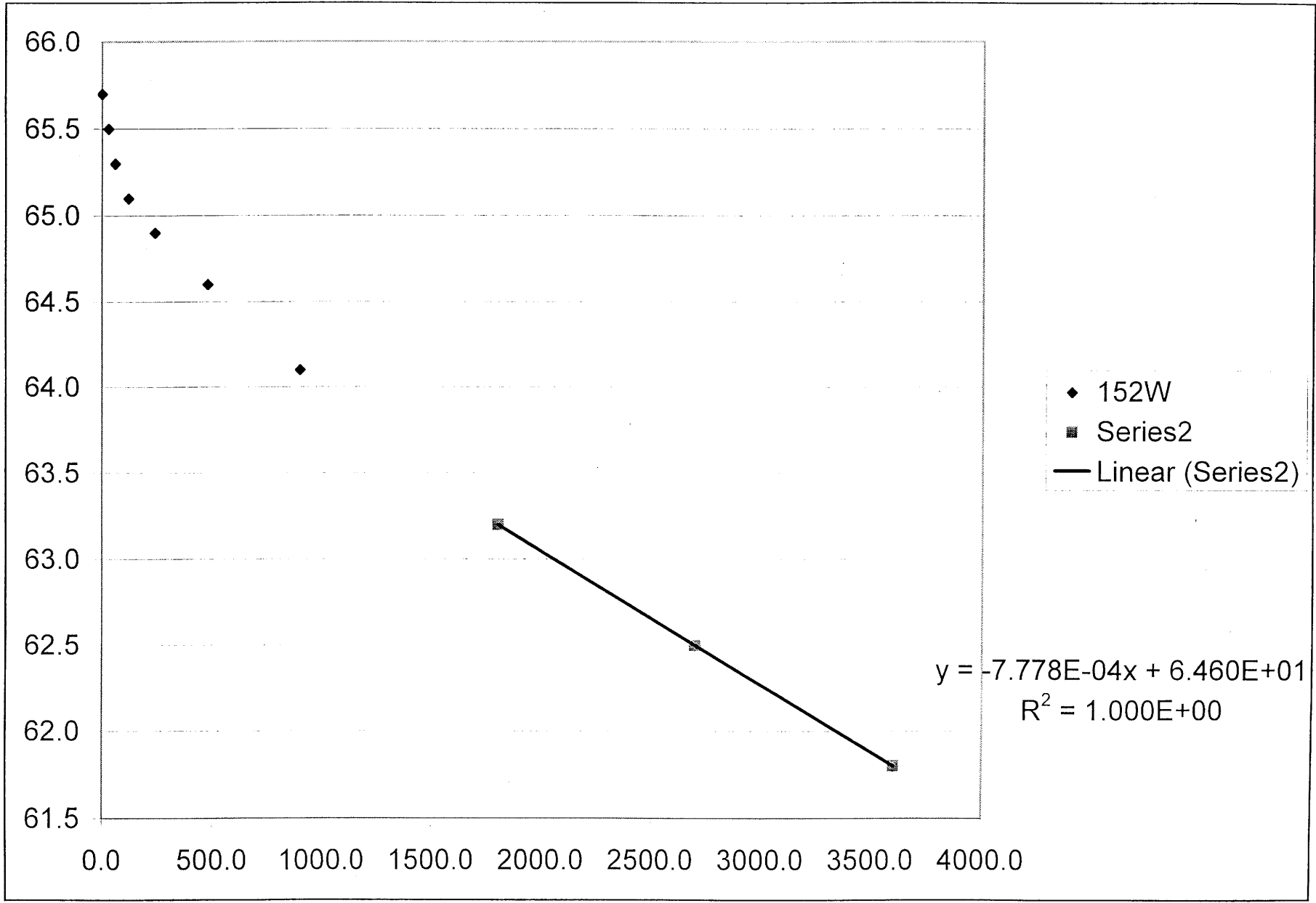

0152W

Given

$$R_{ws} = 25 \text{ mm} = \underline{2.5 \text{ cm}}$$

$$R_{sr} = 9.5''/2 (2.54) = \underline{12.1 \text{ cm}}$$

$$G = 8.5'' (2.54) = \underline{21.6 \text{ cm}}$$

$$H_f = 23.7 \text{ cm} + 15'' (2.54) = \underline{61.8 \text{ cm}}$$

$$L \Rightarrow 2'' \text{ below base of ring} = 10.5'' (2.54) = \underline{26.7 \text{ cm}}$$

$$\text{to } 10.5 - 3 (2.54) = \underline{19.1 \text{ cm}}$$

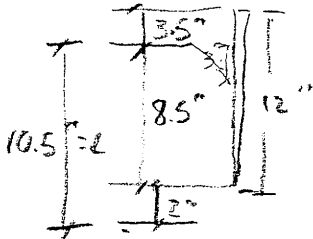

$$P_a = 10 \text{ centibar} (10.2 \text{ cm/centibar}) = \underline{102 \text{ cm}}$$

Find K_{sat}

Solution

$$K_{sat} = \frac{- (2 \frac{dH}{dt} L (R_{ws}/R_{sr})^2)}{H_f + L - P_a/2} \quad \frac{dH}{dt} = -7.778 \times 10^{-4} \text{ cm/s}$$

$$= \frac{- (2 (-7.778 \times 10^{-4} \text{ cm/s}) (26.7 \text{ cm}) (2.5/12.1)^2)}{(61.8 + 26.7 + 102)/2} = \frac{1.773 \times 10^{-3} \text{ cm}^2}{95.3 \text{ cm}}$$

$$= \frac{- (2 (-7.778 \times 10^{-4}) (19.1) (2.5/12.1)^2)}{(61.8 + 19.1 + 102)/2} = \frac{1.268 \times 10^{-3} \text{ cm}^2}{91.5} = 4.4 \times 10^{-5} \text{ cm/s}$$

consider



upper 6" ϕ of pedestal frozen:

$$A_{9.5} = 70.882 \text{ in}^2$$

$$A_6 = 28.274 \text{ in}^2$$

$$\left(\frac{42.608 \text{ in}^2 \times 4}{\pi} \right)^{1/2} = \text{equivalent } \phi = 7.37 \text{ in} = R'_{sr}$$

0152W

$$k_{sat} = \frac{-2(17.778 \times 10^{-4} \text{ cm/s})(19.1) \left(\frac{2.5}{7.37}\right)^2}{(61.8 + 19.1 + 102)/2}$$

$$= \frac{3.42 \times 10^{-3} \text{ cm}^2/\text{s}}{95.3 \text{ cm}} = 3.6 \times 10^{-5} \text{ cm/s}$$

$$k_{sat} = \frac{-2(17.778 \times 10^{-4} \text{ cm/s})(26.7) \left(\frac{2.5}{7.37}\right)^2}{(61.8 + 26.7 + 102)/2}$$

$$= \frac{4.78 \times 10^{-3} \text{ cm}^2/\text{s}}{91.5 \text{ cm}} = 5.2 \times 10^{-5} \text{ cm/s}$$

k_{sat} (cm/s)

R_{gr}	12.1	7.37
L		
26.7	1.9×10^{-5}	3.6×10^{-5}
19.1	1.4×10^{-5}	5.2×10^{-5}

Discussion

k_{sat} is not sensitive to L, is sensitive to R_{gr}

Since upper portion of pedestal was frozen, used approximated frozen diameter to compute k_{sat} ;

i.e. $k_{sat} = \underline{4.4 \times 10^{-5} \text{ cm/s}}$

TP 0154 Field Data Sheets and Plots

Measured Parameters 154

R_{ws} (Radius of Water Supply Reservoir)
5 cm / 2 cm = 2.5 cm

H_f (Final water head reading when water flow valve is shut)
3.8 + h cm = 35.6

R_{sr} (Radius of Soil Ring)
9.5 in ϕ cm = 24/2 = 12.1 cm

P_{min} (Gauge pressure at air entry, a negative value)
8 cm centibars $\times 10.2$ cm/centibar = 81.6 cm

G (Height of gauge above soil surface)
6.375 cm = 16.2 cm

L (Depth from soil surface to wetting front)
9 in cm = 22.9 cm

Data $h_0 = 0.0$ cm = 12.5 in

Time (MST) (min)	Reservoir Reading (cm)	Head (cm)	dH (cm)	dT (s)	dH/dT (cm/s)	mean dH/dT
0	11:31:00	27.7		0		
0.5	:36	23.4				
1	:32:00	21.6				
2	:33:00	17.5				
4	:35:00	10.7				
6	:37:00	5.5				
0	11:39:00	28.8				
0.5	:30	24.9				
1	:40:00	23.7				
2	:41:00	21.8				
4	:43:00	18.5				
8	:47:00	13.8				
15	:54:00	9.0				
30	12:09:00	3.8				

ambient temp
 = 12°C

P_a (Air entry value, negative value) = $P_{min} + G + L = 81.6 + 16.2 + 22.9 = \underline{120.7 \text{ cm}}$

dH/dT = (Change in head/Change in time) for last two data points = -0.0073 cm/s

$K_{sat} = -(2 * dH/dT * L * (R_{ws}/R_{sr})^2) / (H_f + L - (0.5 * P_a))$ (cm/s) = 0.0144 / -1.85 = 7.7×10^{-3} cm/s
 $\approx 8 \times 10^{-3}$ cm/s
 $= 77 \times 10^{-4}$ cm/sec

0154

Given

$$\text{Radius of reservoir} = 50 \text{ mm} / 2 = 25 \text{ mm} = \underline{2.5 \text{ cm}} = R_{ws}$$

$$\begin{aligned} \text{Radius of soil ring (pedestal)} &\sim 9.5 \text{ " dia} \\ &= 4.75 \text{ " radius} \left(\frac{2.54 \text{ cm}}{\text{in}} \right) \\ &= \underline{12.1 \text{ cm}} = R_{sr} \end{aligned}$$

$$\text{Gage height} = 6 \frac{3}{8} \text{ " } = 6.375 \left(\frac{2.54 \text{ cm}}{\text{in}} \right) = \underline{16.2 \text{ cm}}$$

$$H_f = 3.8 \text{ cm} + 12.5 \text{ " } \left(\frac{2.54 \text{ cm}}{\text{in}} \right) = \underline{35.6 \text{ cm}}$$

$$P_{min} = 8 \text{ centibars} \left(\frac{10.2 \text{ cm}}{\text{centibar}} \right) = \underline{81.6 \text{ cm}}$$

$$L \approx 9 \text{ in} \left(\frac{2.54}{\text{cm}} \right) = \underline{22.9 \text{ cm}}$$

Find

K_{sat}

Solution

$$K_{sat} = - \left(2 \frac{dH}{dt} L \left(\frac{R_{ws}}{R_{sr}} \right)^2 / (H_f + L - \frac{1}{2} P_a) \right)$$

$$\frac{dH}{dt} = -5.778 \times 10^{-3} \text{ cm/sec (see attached graph)}$$

$$K_{sat} = - \frac{ \left(2 (-5.778 \times 10^{-3} \text{ cm/sec}) (22.9 \text{ cm}) \left(\frac{2.5}{12.1} \right)^2 \right) }{ (35.6 + 22.9 + 81.6) / 2 }$$

$$= \frac{ 1.130 \times 10^{-2} \text{ cm}^2/\text{s} }{ 70 \text{ cm} } = \underline{1.6 \times 10^{-4} \text{ cm/sec}}$$

AEP tests TP 0154

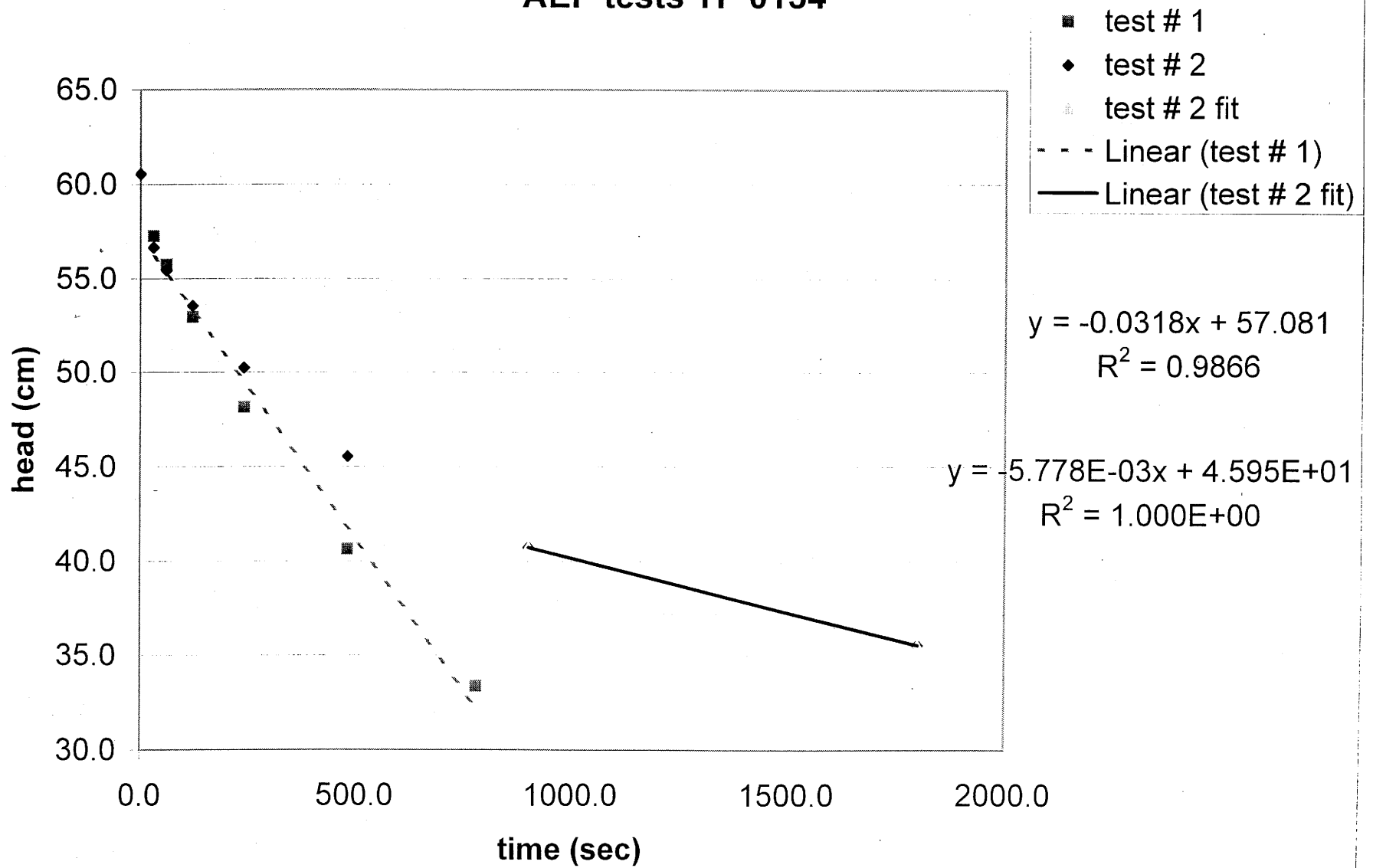

TP 0156 Field Data Sheets and Plots

Air-Entry Permeameter Tests

0156 W

Date: 12-02-05

Staff: Greg Swift

Ralph Rupp

Measured Parameters

R_{ws} (Radius of Water Supply Reservoir)

50/2 = 25 cm

H_f (Final water head reading when water flow valve is shut)

37.1 cm

R_{sr} (Radius of Soil Ring)

11.11 cm (8" + 1 1/2")

P_{min} (Gauge pressure at air entry, a negative value)

203.9 cm

G (Height of gauge above soil surface)

7.75" cm 19.7

L (Depth from soil surface to wetting front)

17.8 cm

Data

$H_{air} = r_{soil} + 1' 1.5" = 34.3$

12:12
12:16
12:20
12:27
2:38
12:41
12:43
12:45
12:49
12:56
1:01
1:06

Time (min)	Reservoir Reading (cm)	Head (cm)	dH (cm)	dT (s)	dH/dT (cm/s)	mean dH/dT
0	27.3	27.3				
0.5	23.9	23				
1.0	23.1					
1.5	22.5					
2.0	22.0					
4.0	19.8					
8.0	15.6					
15.0	9.2					
25.6	4.75	0.2				
0	29.9					
0.5	27.5					
1.0	27.0					
2.0	25.7					
4.0	23.1					
8.0	18.5					
15.0	11.3					
20.0	6.6					
25.0	2.5					

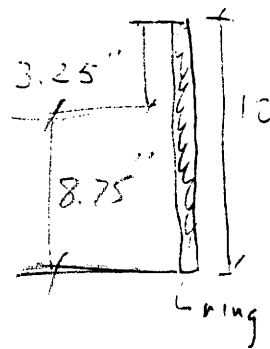

1' 1.5"

P_a (Air entry value, negative value) = $P_{min} + G + L = 203.9 + 19.7 + 17.8$

-166.40

dH/dT = (Change in head/Change in time) for last two data points

-0.0187
-1.1227

cm/s
(2.3×10^{-4} cm/s)

$K_{sat} = -2 * dH/dT * L * (R_{ws}/R_{sr})^2 / (H_f + L - (0.5 * P_a))$ (cm/s)

$$= -(-3.48 \times 10^{-2}) / (37.1 + 17.8 - (0.5 * 203.9))$$

$$= 3.48 \times 10^{-2} / 138.1 =$$

2.5×10^{-4} cm/s

6.3×10^{-4} w/o P_a

Air-Entry Permeameter Tests

Date:

0156W cont

Staff:

Measured Parameters

R_{ws} (Radius of Water Supply Reservoir)

cm

H_f (Final water head reading when water flow valve is shut)

28.4 cm

R_{sr} (Radius of Soil Ring)

cm

P_{min} (Gauge pressure at air entry, a negative value)

20 cent / $P_{min} = 203.94$ cm

G (Height of gauge above soil surface)

cm

L (Depth from soil surface to wetting front)

7" cm - 17.8

Data

Actual
1:10
1:11
1:12
1:14
1:18
1:25
1:30
1:35

Time (min)	Reservoir Reading (cm)	Head (cm)	dH (cm)	dT (s)	dH/dT (cm/s)	mean dH/dT
0	32.7					
0.5	31.1					
1.0	29.4					
2.0	28.1					
4.0	25.5					
8.0	20.5					
15.0	12.8					
20.0	7.6					
25.0	2.8					

P_a (Air entry value, negative value) = $P_{min} + G + L$

dH/dT = (Change in head/Change in time) for last two data points cm/s

$K_{sat} = -(2 * dH/dT * L * (R_{ws}/R_{sr})^2) / (H_f + L - (0.5 * P_a))$ (cm/s) cm/s

AEP tests TP 0156

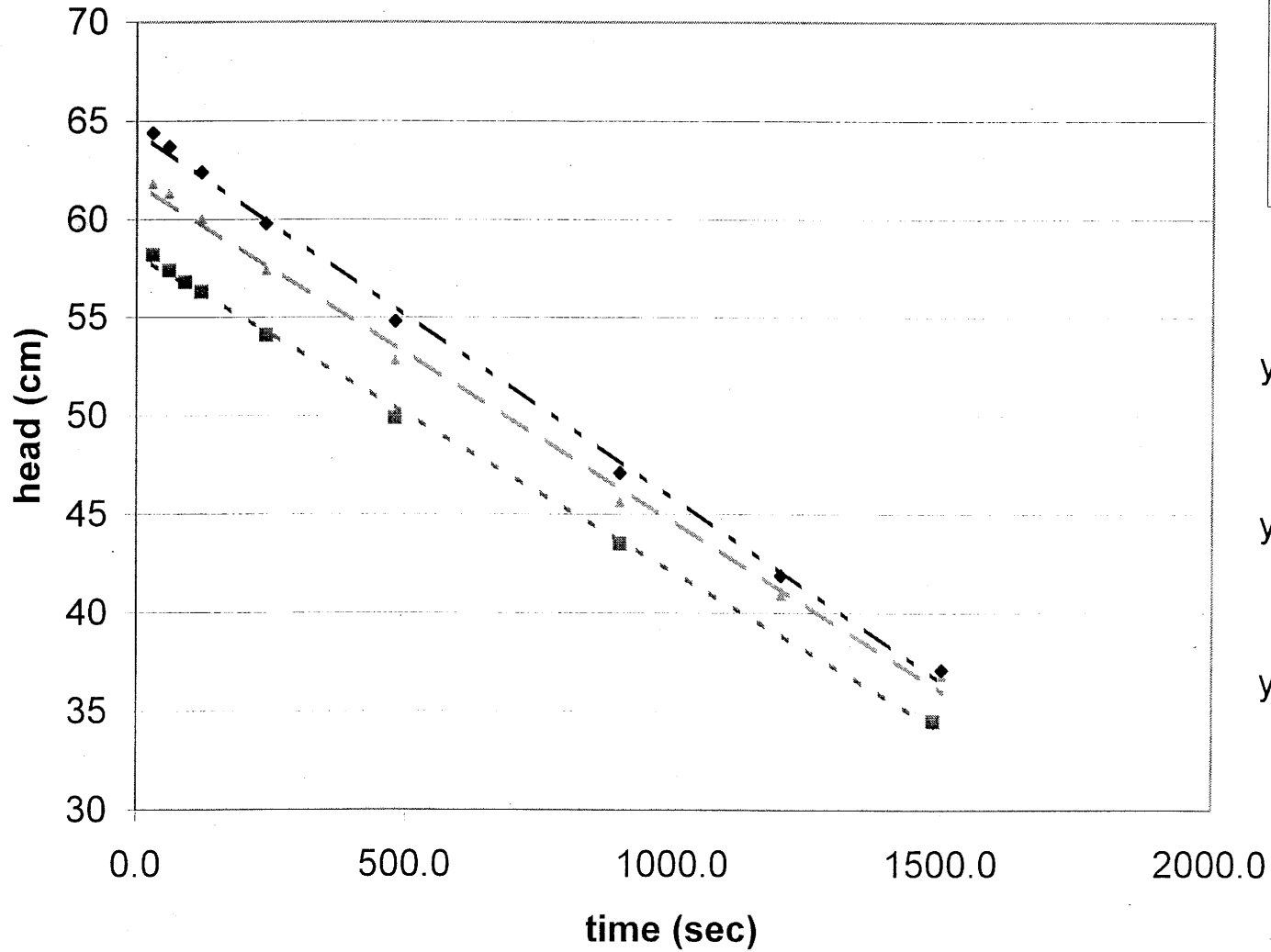

- test # 1
- ▲ test # 2
- ◆ test # 3
- Linear (test # 2)
- - - Linear (test # 1)
- · - Linear (test # 3)

$$y = -0.0162x + 58.223$$
$$R^2 = 0.9985$$

$$y = -0.0173x + 61.857$$
$$R^2 = 0.9963$$

$$y = -0.0187x + 64.496$$
$$R^2 = 0.9979$$

0156W

G_w $R_{ws} = 25 \text{ mm} = \underline{2.5 \text{ cm}}$

$$R_{sr} = \frac{\left(\frac{8+9.5}{2}\right) 2.54}{2} = \underline{11.1 \text{ cm}}$$

$$G = 7\frac{3}{4}'' (2.54) = \underline{19.7 \text{ cm}}$$

$$H_f = 13\frac{1}{2}'' (2.54) + 2.8 \text{ cm} = \underline{37.1 \text{ cm}}$$

$$P_{min} = (20 \text{ cent. bars} \left(\frac{10.2 \text{ cm}}{\text{cent. bar}} \right)) = \underline{204 \text{ cm}}$$

$$L = 7'' (2.54) = \underline{17.8 \text{ cm}}$$

Find

k_{sat}

Solution

$$k_{sat} = \frac{-\left(2 \frac{dH}{dL} L \left(\frac{R_{ws}}{R_{sr}}\right)^2\right)}{H_f + L - \frac{P}{2}}$$

$$P_a = P_{min} + G + L = 204 + 19.7 + 17.8 = 241.5$$

$\frac{dH}{dL}$ = -avg. of all three slopes shown on attached plots

$$\frac{0.0162 + 0.0173 + 0.0187}{3} = 0.0174 \text{ cm/sec}$$

$$k_{sat} = \frac{0.0314 \text{ cm}^2/\text{sec}}{120.75 \text{ cm}} = \underline{2.6 \times 10^{-4} \text{ cm/sec}}$$

U.S. Department of Energy—Grand Junction, Colorado

Calculation Cover Sheet

Calc. No.: MOA-02-03-2006-2-10-00 Discipline: Hydrologic Properties
Doc. No.: X0147300

No. of Sheets: 6

Location: Attachment 3, Appendix B

Project: Moab UMTRA Project

Site: Crescent Junction Disposal Site

Feature: Field Permeability "Bail" Testing

Sources of Data:

Bail testing records were obtained electronically from pressure transducers installed in coreholes at the Crescent Junction Site during the field characterization project, November 2005 through January 2006.

Sources of Formulae and References:

Freeze, R. Allen, and J.A. Cherry, 1979. *Groundwater*, Prentice-Hall, Inc., Englewood Cliffs, New Jersey.

Hvorselv, M.J., 1951. *Time Lag and Soil Permeability in Ground-Water Observations*, Bulletin No. 36
U.S. Waterways Experiment Station, U.S. Army Corps of Engineers, Vicksburg, Mississippi.

Preliminary Calc.

Final Calc.

Supersedes Calc. No.

Author:

Mark Kautley 5-31-07
Name Date

Checked
by:

G. Gray 5/30/07
Name Date

Approved
by:

Mark Kautley 5/31/07
Name Date

Dave Peterson 5/31/07
Name Date

R. Metzger 31 May 07
Name Date

D Metzger MAY 31 07
Name Date

No text for this page

Problem Statement:

Preliminary site selection performed jointly by the U.S. Department of Energy (DOE) and the Contractor has identified a 2,300-acre withdrawal area in the Crescent Flat area just northeast of Crescent Junction, Utah, as a possible site for a final disposal cell for the Moab uranium mill tailings. The proposed disposal cell would cover approximately 250 acres. Based on the preliminary site-selection process, the suitability of the Crescent Junction Disposal Site is being evaluated from several technical aspects, including geomorphic, geologic, hydrologic, seismic, geochemical, and geotechnical. The objective of this calculation is to impart the field permeability "bail test" results obtained from the Mancos Shale during the investigation of subsurface conditions at the Crescent Junction Disposal Site.

This calculation will be incorporated into Attachment 3 (Hydrology) of the Remedial Action Plan and Site Design for Stabilization of Moab Title I Uranium Mill Tailings at the Crescent Junction, Utah, Disposal Site (RAP), and summarized in the appropriate sections of the Remedial Action Selection (RAS) report for the Moab Site.

Obtaining the hydraulic parameters of the host rock in which a disposal site will be situated is one of the fundamental measurements required to evaluate the suitability of the site. Because the bedrock is a shale aquitard containing only sparse saline groundwater, the number and type of measurements that might be made are rather limited. In addition, the types of measurements that are available, packer tests and piezometer tests, reveal different characteristics about the rock mass. Packer tests, which reveal spatially discrete estimates of hydraulic conductivity, were carried out on this project and are documented in the "Field Permeability 'Packer' Testing" calculation (Attachment 3, Appendix C) and in the "Saturated Hydraulic Conductivity Determination of Weathered Mancos Shale" calculation (Attachment 3, Appendix A).

Piezometer tests, which are described in Freeze and Cherry (1979), will yield vertically averaged hydraulic conductivities that do not represent the full vertical variability in hydraulic conductivity. These averaged hydraulic conductivity determinations were done to evaluate hydraulic properties representative of the entire rock mass. The tests are performed by causing an instantaneous change in the water level in a piezometer through a sudden introduction (or removal) of a known volume of water. When the water is removed, the tests are often called *bail tests*. For this project the hydraulic properties of the Mancos Shale are important for the purpose of developing the water resources protection strategy. The tests were performed in coreholes 201, 202, 203, 204, and 208 (see Table 1).

Method of Solution:

Instantaneous removal of ground water from each corehole was accomplished using dedicated submersible pumps. Water levels were measured using submersible electronic pressure transducers that were programmed to read either at 5- or 15-minute intervals. The water-level recovery data were downloaded into a portable laptop computer and then copied onto the data analyst's computer. The test results were analyzed using equation 8.34 in Freeze and Cherry (1979).

For a piezometer intake of length $(L/R) > 8$, Hvorslev (1951) has evaluated the so-called *shape factor* F of the piezometer and presented the following equation for calculating the hydraulic conductivity:

$$K = [r^2 \ln (L/R)] / (2LT_0), \quad [1]$$

where:

K = hydraulic conductivity [length/time]

r = radius of corehole [length]

L = length of ground water intake zone [length]

R = radius of ground water intake zone [length]

T_0 = basic time lag [time]

To interpret a set of field recovery data, the data are plotted graphically in the form of dimensionless drawdown $[(H-h)/(H-H_0)]$ versus elapsed time. The basic time lag value is read off the graph at the point where the dimensionless drawdown equals 0.37.

Assumptions:

- Pumping ground water from a corehole tapping a low-permeability formation causes a valid, essentially instantaneous change in the water level.
- Bail tests in bedrock systems such as the Mancos Shale yield estimated values of average hydraulic conductivity for the entire test interval.
- The absence of a piezometer tube does not invalidate the recovery test data.

Calculation:

To interpret a set of field recovery data, the data are plotted graphically in the form of dimensionless drawdown $[(H-h)/(H-H_0)]$ versus elapsed time. Appendix A presents plots of each test that was conducted during this study. Each plot displays dimensionless drawdown versus the elapsed time since the bail test began. Using the Microsoft Excel program, the raw drawdown data were converted to dimensionless drawdowns, and the dimensionless drawdowns were plotted versus elapsed time. The basic time lag value was read off the graph at the point where the dimensionless drawdown equals 0.37. The basic time lag value is posted on each plot. Equation 1 was then used to solve for hydraulic conductivity.

Inputs to the equation are:

r = radius of corehole [length] = 0.16 ft

L = length of ground-water intake zone [length] = depth of static water in corehole

$L_{\text{corehole 201}}$ = 95 ft

$L_{\text{corehole 202}}$ = 188 ft

$L_{\text{corehole 203}}$ = 203 ft

$L_{\text{corehole 204}}$ = 75 ft

$L_{\text{corehole 208}}$ = 120 ft

R = radius of ground-water intake zone [length] = 0.16 ft

T_0 = basic time lag [time] = 0.37

Results from these calculations are tabularized below:

Table 1. Bail Test Results

Corehole	Hydraulic Conductivity (cm/sec)				
	Test 1	Test 2	Test 3	Test 4	Geometric Mean
201	1.4×10^{-6}	1.4×10^{-6}	1.9×10^{-6}	ND	1.6×10^{-6}
202	4.3×10^{-7}	3.9×10^{-7}	4.3×10^{-7}	ND	4.2×10^{-7}
203	2.4×10^{-6}	2.6×10^{-6}	2.6×10^{-6}	2.3×10^{-6}	2.5×10^{-6}
204	Indeterminable	Indeterminable	3.1×10^{-7}	ND	3.1×10^{-7}
208	3.1×10^{-7}	3.3×10^{-7}	3.1×10^{-7}	ND	3.2×10^{-7}

ND – No data were gathered for this test.

Discussion:

Results obtained from this calculation represent average hydraulic conductivities for the Mancos Shale. These results were obtained from the unweathered zones of the Mancos Shale that underlie the Crescent Junction Disposal Site. Sources of the ground water appear to be micro to mini fractures and/or bedding planes within the rock formation. The hydraulic conductivities of discrete zones contributing the water were not measured with this method. This method yields average hydraulic conductivities of the portions of the coreholes that are below the fluid level in that borehole.

Conclusion and Recommendations:

Overall, the hydraulic conductivity of the Mancos Shale was determined to be very low at the Crescent Junction Site. Based on results of bail testing, and in conjunction with findings of field investigations, the Crescent Junction Site appears to be suitable for disposal of the Moab uranium mill tailings and contaminated material. Based on this information, and in conjunction with findings of field investigations, this site is deemed suitable for the intended use.

Computer Source:

Microsoft Excel

End of current text

Appendix A

Copies of Packer Testing Raw-Data Sheets and Analysis Sheets

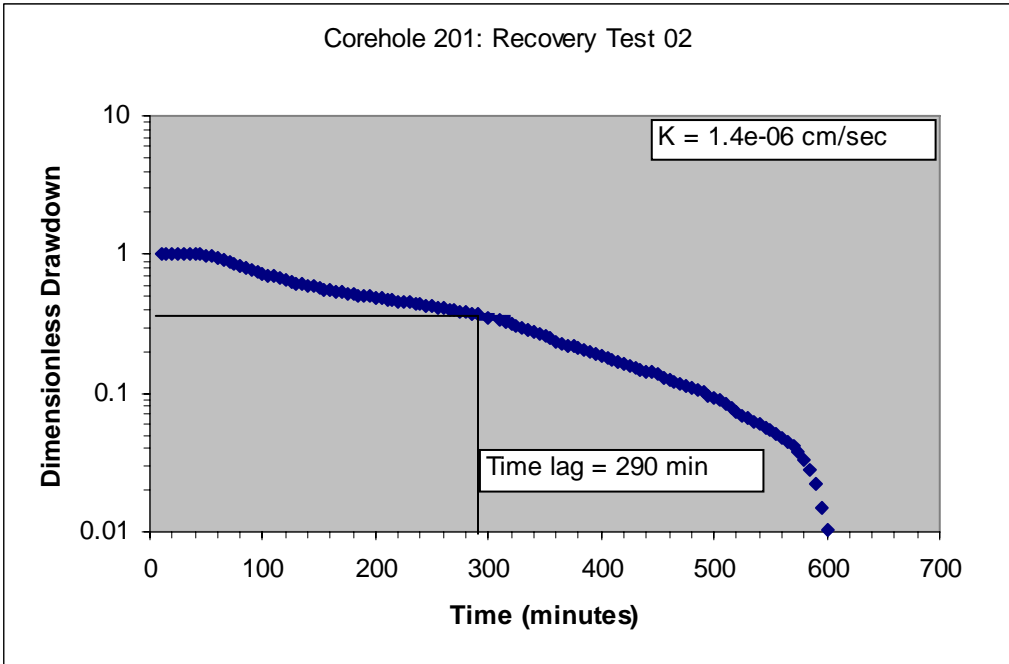
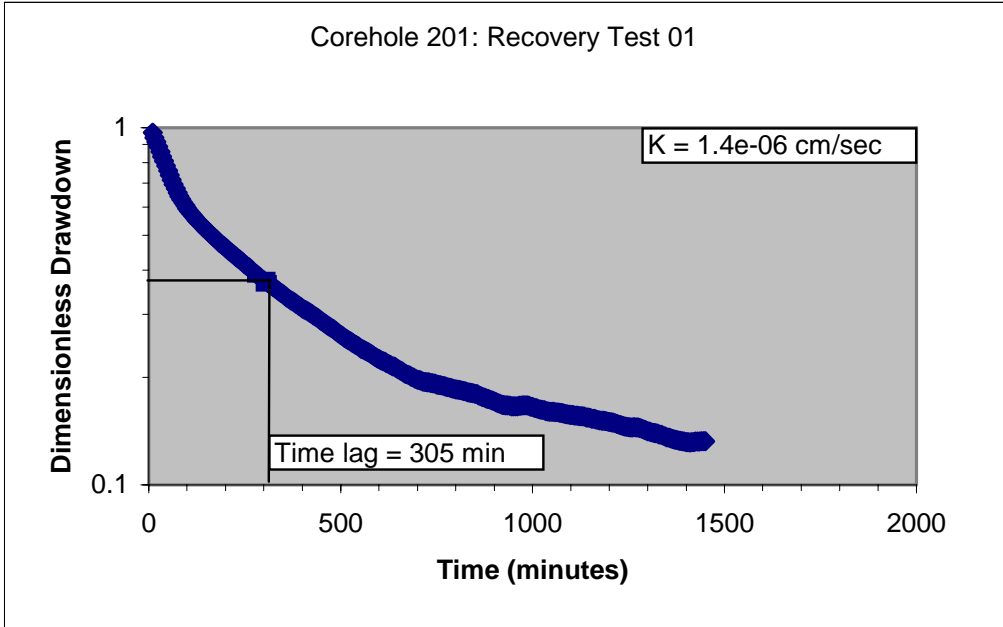

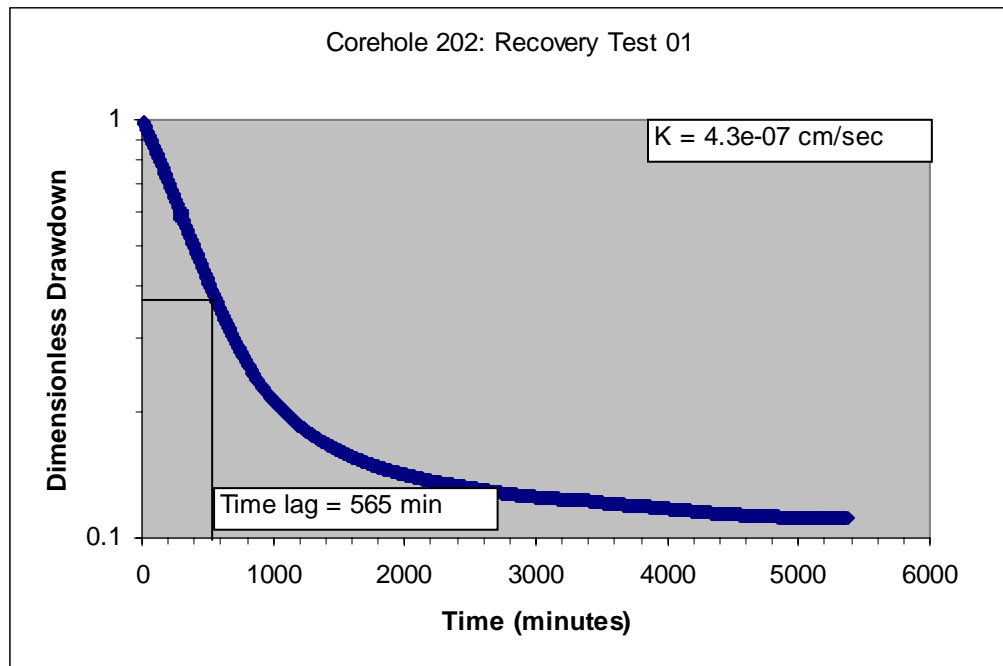
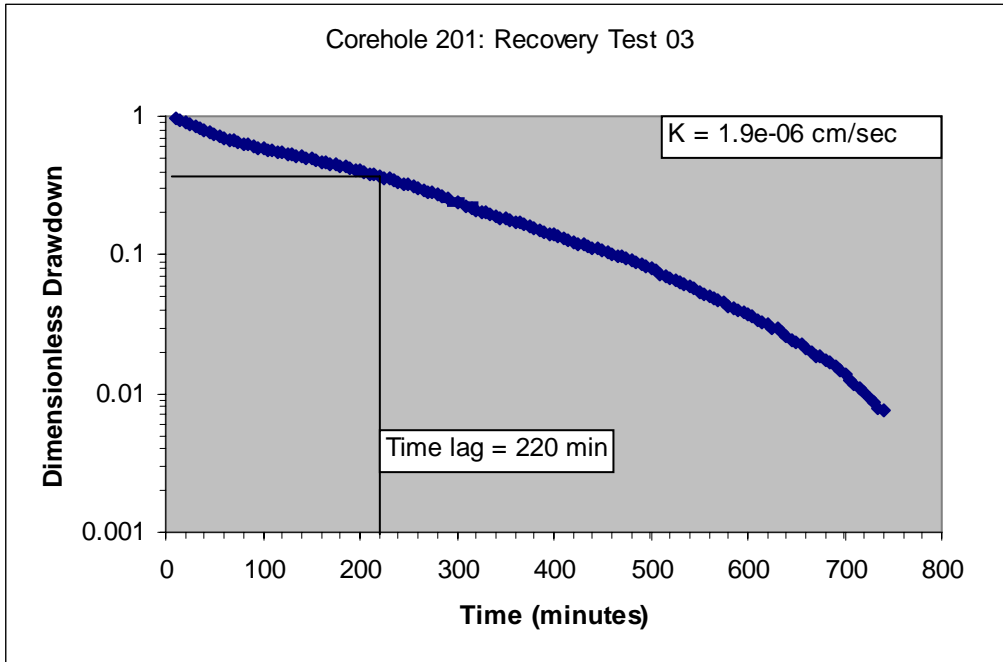

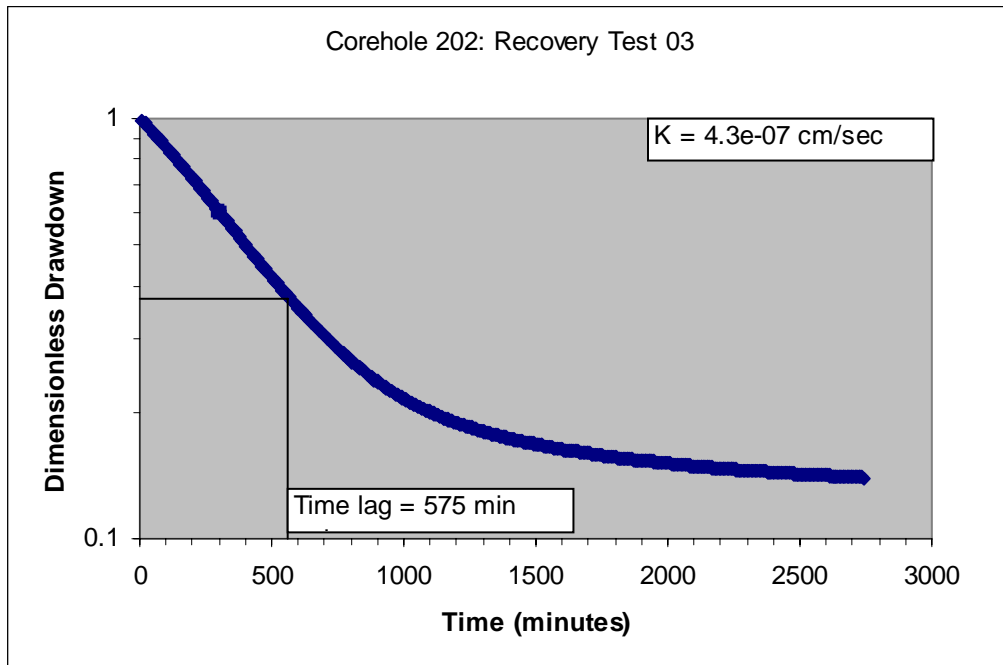
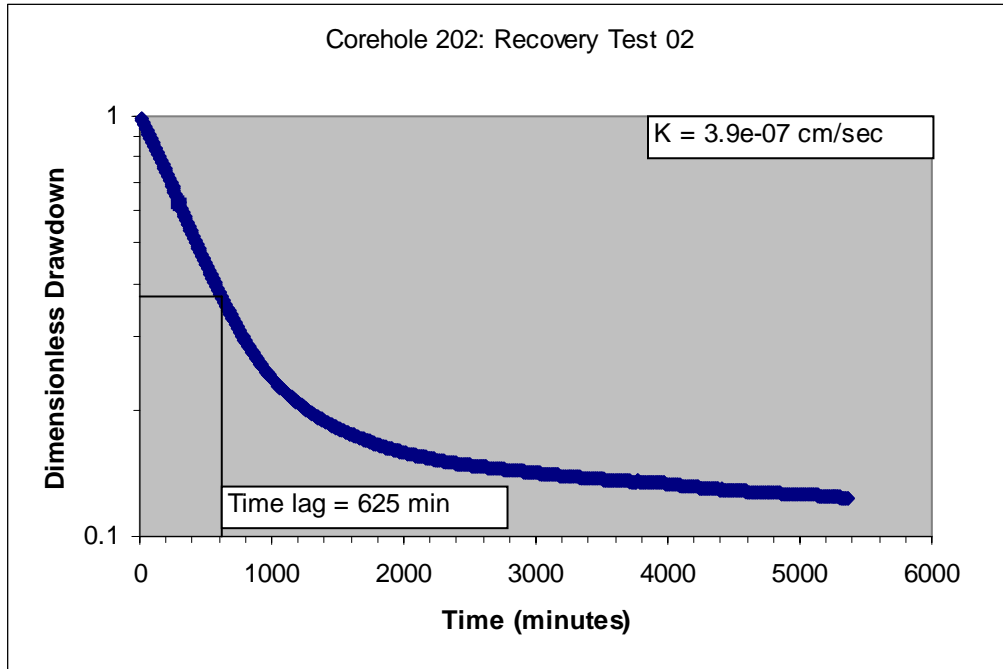

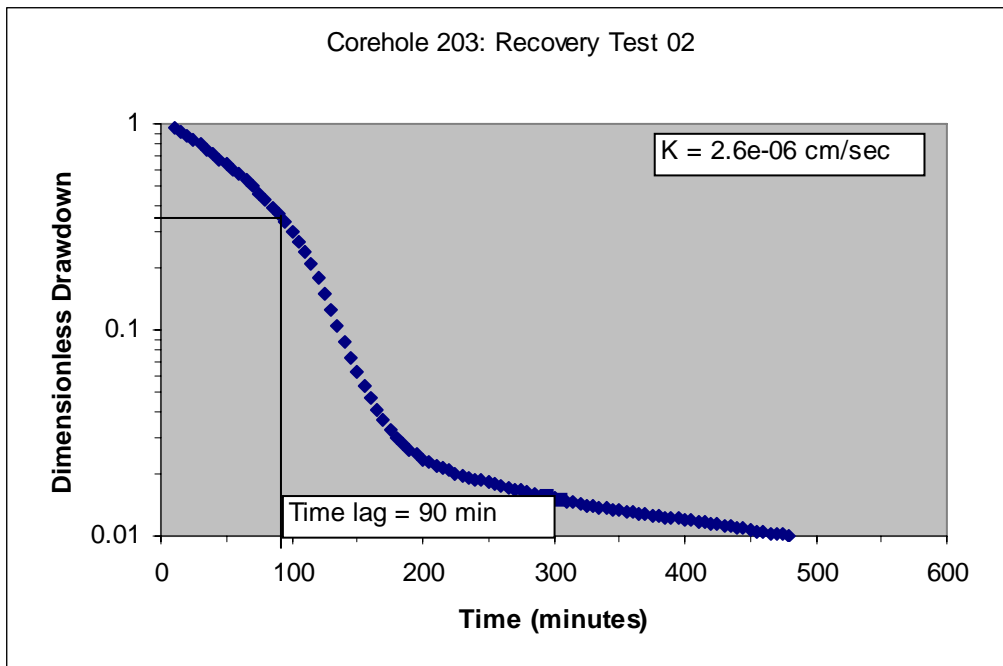
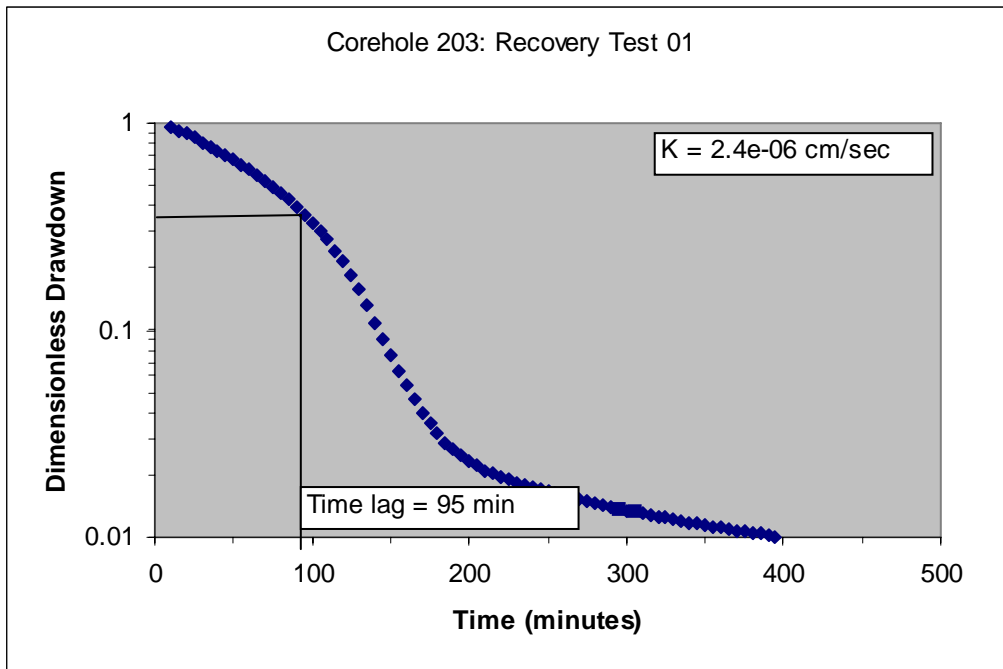

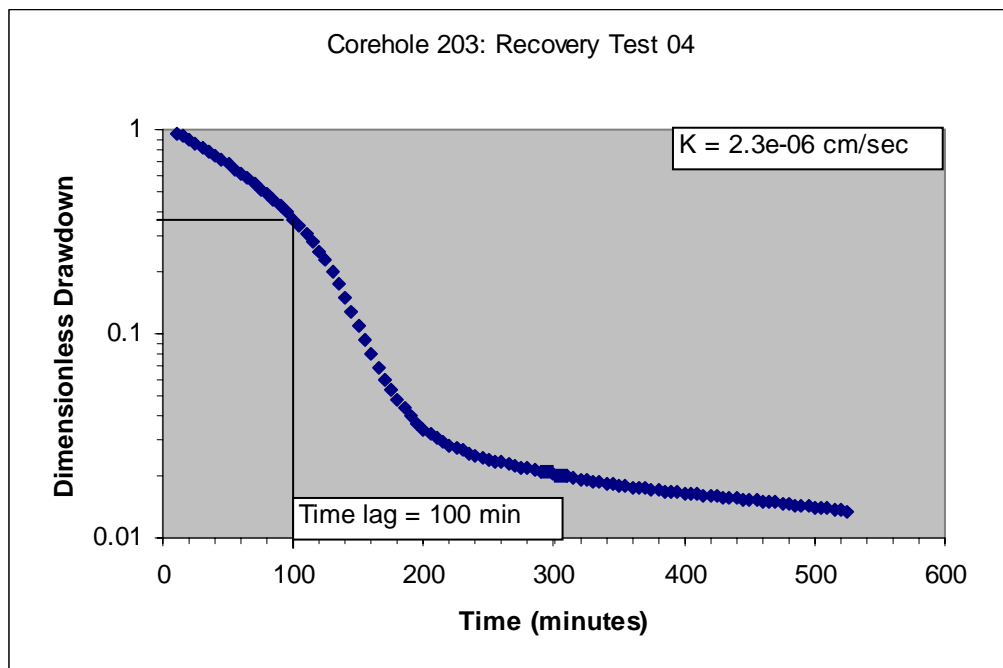
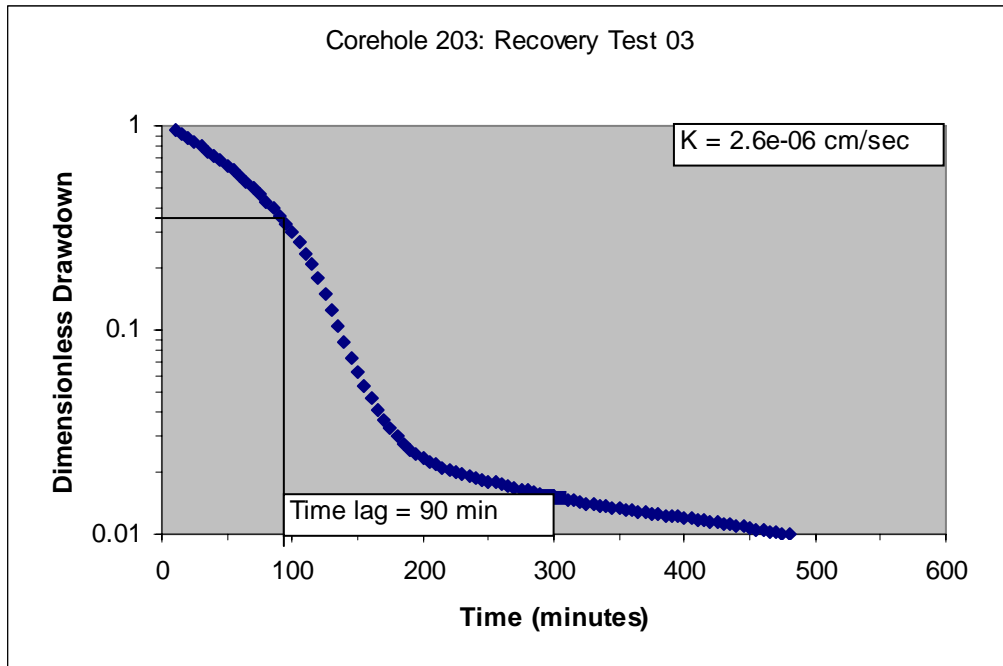

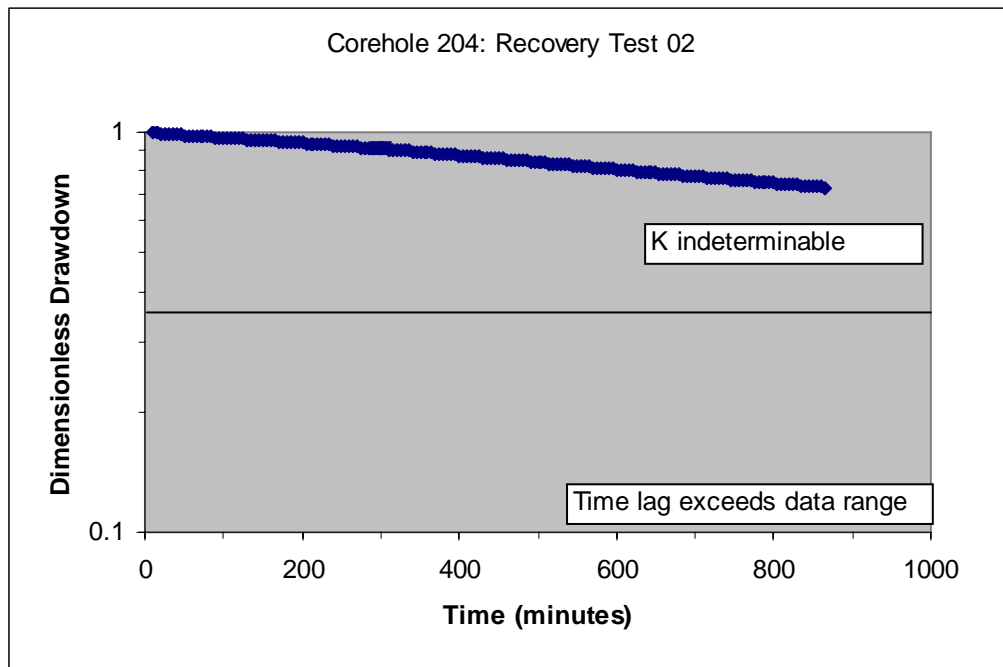
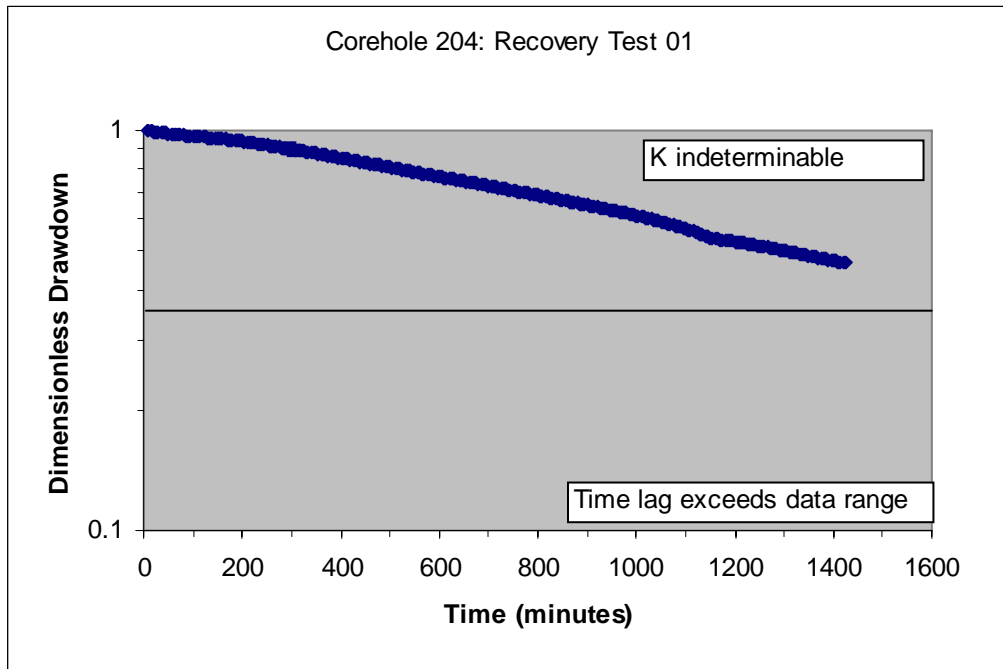

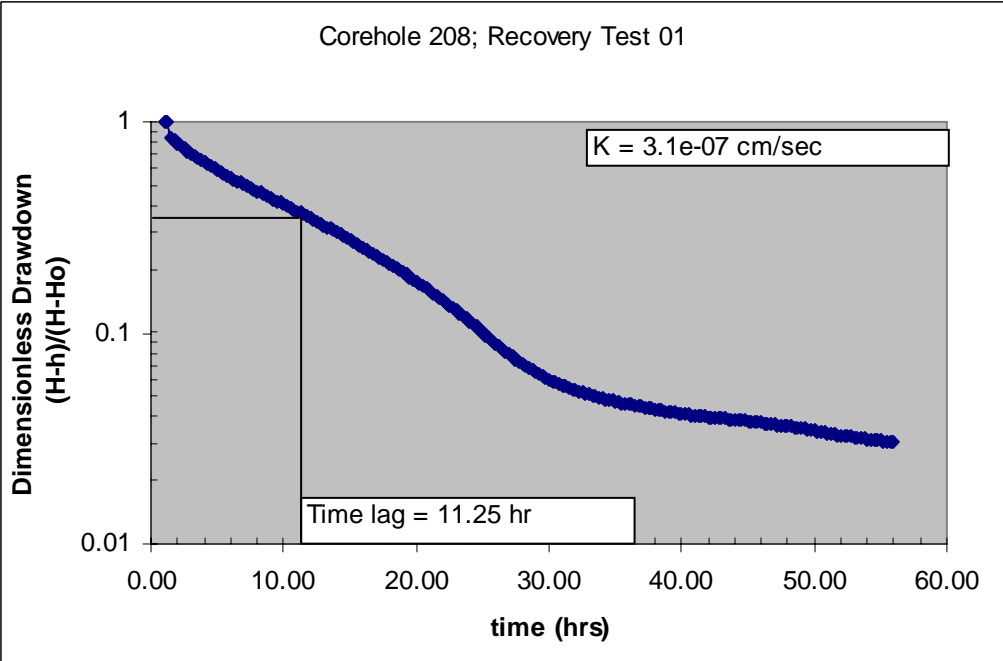
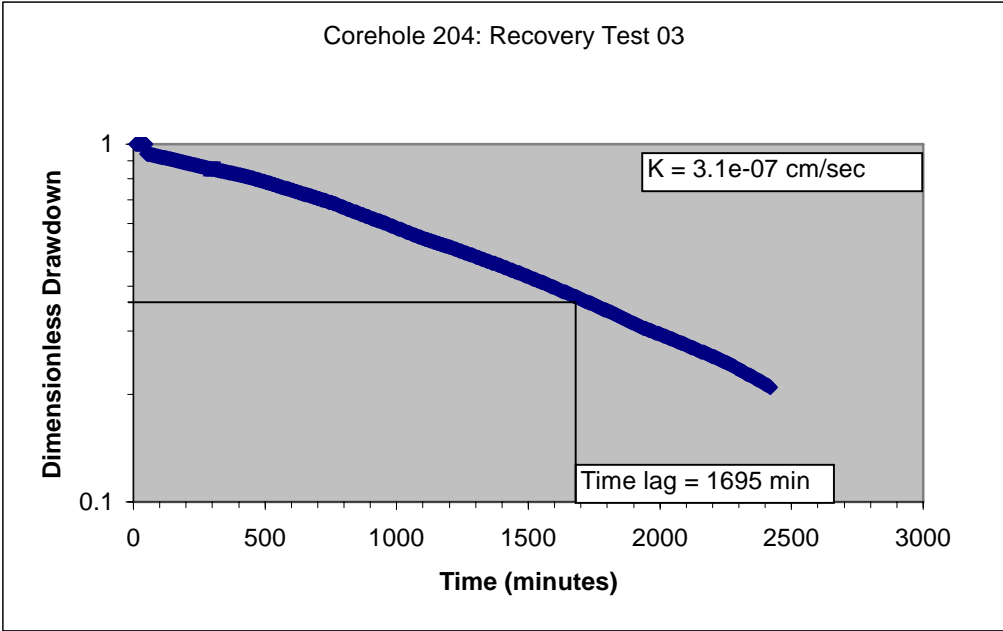

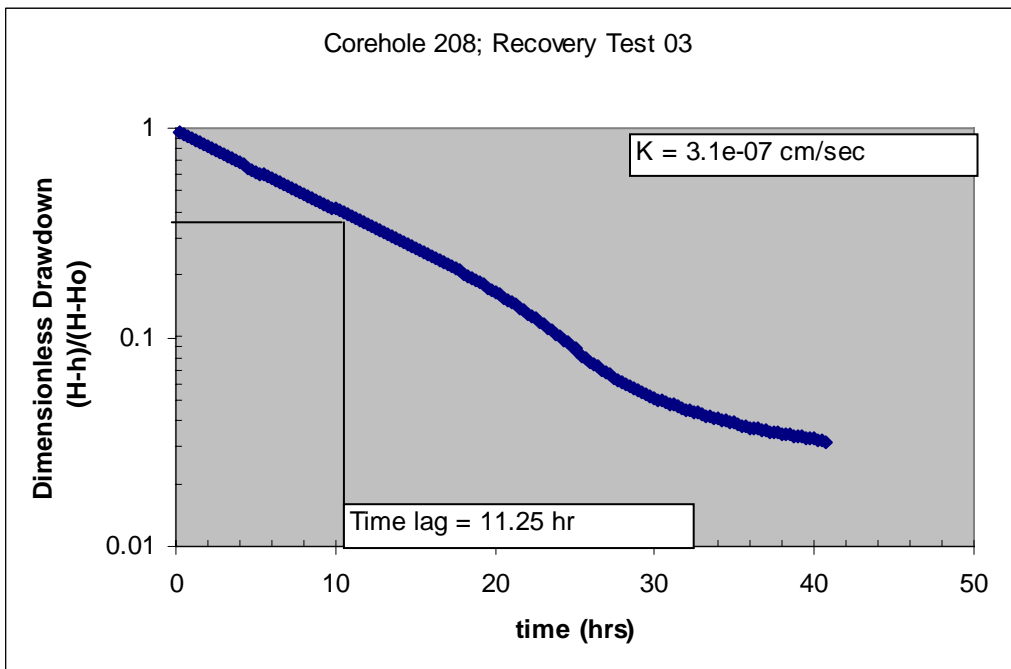
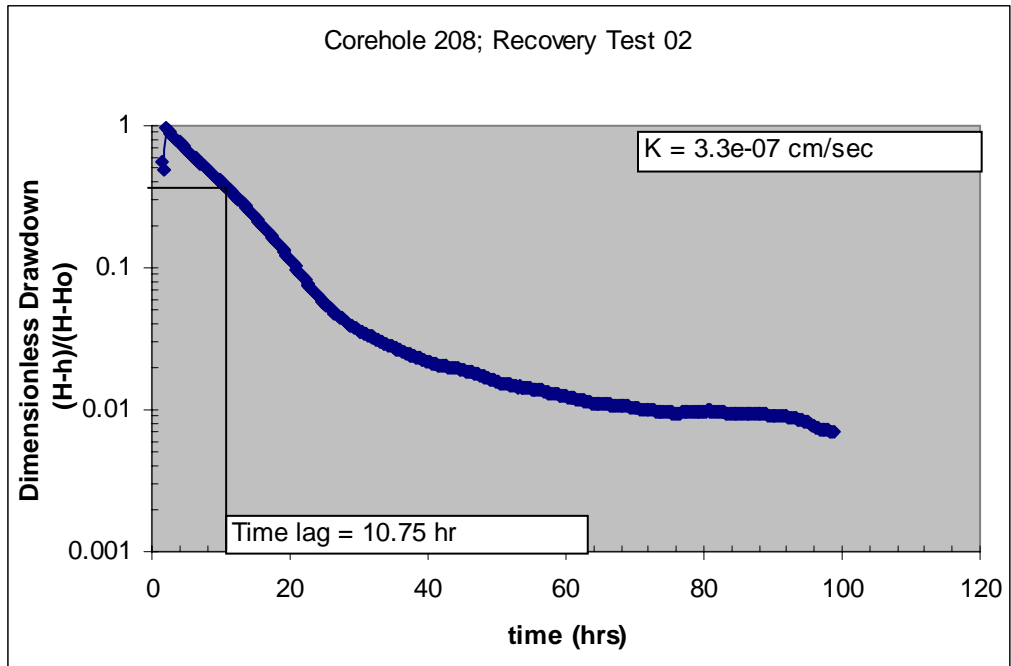

U.S. Department of Energy—Grand Junction, Colorado

Calculation Cover Sheet

Calc. No.: MOA-02-03-2006-2-06-00 Discipline: Hydrologic Properties No. of Sheets: 8
Doc. No.: X0140400

Location: Attachment 3, Appendix C

Project: Moab UMTRA Project

Site: Crescent Junction Disposal Site

Feature: Field Permeability "Packer" Testing

Sources of Data:

Packer testing records obtained at the Crescent Junction Site during the field characterization project November 2005 through January 2006.

Sources of Formulae and References:

U.S. Bureau of Reclamation (USBR), 1998. *Engineering Geology Field Manual*, Second Edition, U.S. Department of the Interior, Washington D.C., (Chapter 17 "Water Testing for Permeability," available online at: www.usbr.gov/pmts/geology/geolman2/Chapter17.pdf).

Preliminary Calc. Final Calc. Supersedes Calc. No.

Author: Mark Kauder 5-31-07 Checked by: Colby Lee 5/30/07
Name Date Name Date

Approved by: Frank Kump 5/31/07
Name Date

Steve Peterson 5/31/07
Name Date
John 31 May 07
Name Date
D. White 5/31/07
Name Date

No text for this page

Problem Statement:

During November 2005 through January 2006, the U.S. Department of Energy (DOE) contractor S.M. Stoller Corporation completed field permeability “packer” tests at the Crescent Junction Disposal Site. The objectives of these tests were to:

- Estimate the horizontal hydraulic conductivity of the weathered and unweathered sections of the Mancos Shale that underlie the disposal site.
- Evaluate the hydrogeologic suitability of the proposed disposal site.
- Establish design parameters for the proposed disposal site.
- Help formulate a water resources protection strategy for the proposed disposal site.

Method of Solution:

Packer tests are conducted in a corehole after the hole is cored and flushed with clear water. The method consists of lowering the testing apparatus into the corehole, inflating the packers so that they fit snugly against the wall of the corehole, and then injecting water under pressure into the test interval. The flow of water into the test interval is measured with a flow meter. The flow rate of water into the test interval is measured as a function of the injection pressure. This provides a measure of the hydraulic conductivity of the rock formation.

HQ-wire line core drilling was used to advance three shallow coreholes into the weathered Mancos Shale to a depth of 40 feet (ft) below the ground surface, and ten coreholes into the relatively unweathered Mancos Shale to a depth of 300 ft below the land surface. Corehole logs that describe the lithologic materials encountered during drilling are presented in the “Corehole Logs” calculation (Attachment 5, Appendix A).

Packer test methods are described in the U.S. Bureau of Reclamation Engineering Geology Field Manual (USBR 1998). Several methods are potentially applicable, depending on the zone that is being tested. The zone determinations and packer configurations are defined in Figure 1. According to Figure 1, there are three potential zones in the subsurface and two potential packer configurations. The packer tests for this project were done in all three zones, and both packer configurations were used. A single-packer system was used in the shallow coreholes (0211, 0212, and 0213) and each of the single-packer tests was performed above the water level in zone 1. Dual-packer tests were completed in the deep coreholes (0204 and 0208) in zones 1, 2, and 3, above and below the water table. Figure 2 presents the locations where the packer tests were undertaken. A *Moyno* pump was used to deliver steady, even pressure to the test interval. Totalized flows were read from a mechanical, inline flow meter until they stabilized.

In coreholes 0211, 0212, and 0213, the tests were done in the shallow, weathered-bedrock intervals while the hole was being advanced. Water for coring and washing the selected test interval was obtained from the Thompson Springs municipal water supply system. The single-packer assembly was lowered through the drill rod into the shallow test interval using a wire line packer system (Figure 3). A 10-ft-long test interval was used for each injection test. The packer was inflated to 100 pounds per square inch (lb/in^2) to isolate each test interval.

Test intervals 20–30 ft and 30–40 ft below ground surface were selected to evaluate the hydraulic properties of the weathered Mancos Shale. Guidance provided in the Manual (USBR 1998, p.127) recommends that relatively homogeneous but fractured rock (such as the weathered Mancos Shale) can be tested at 1 lb/in^2 per ft of test-interval depth. Consequently, water was injected at 5-lb/in^2 , 10-lb/in^2 , and again at 5-lb/in^2 gage pressure at the surface. When combined with the hydrostatic pressure between the pressure gage and the test interval, the total head was less than the critical pressures that could have damaged the formation.

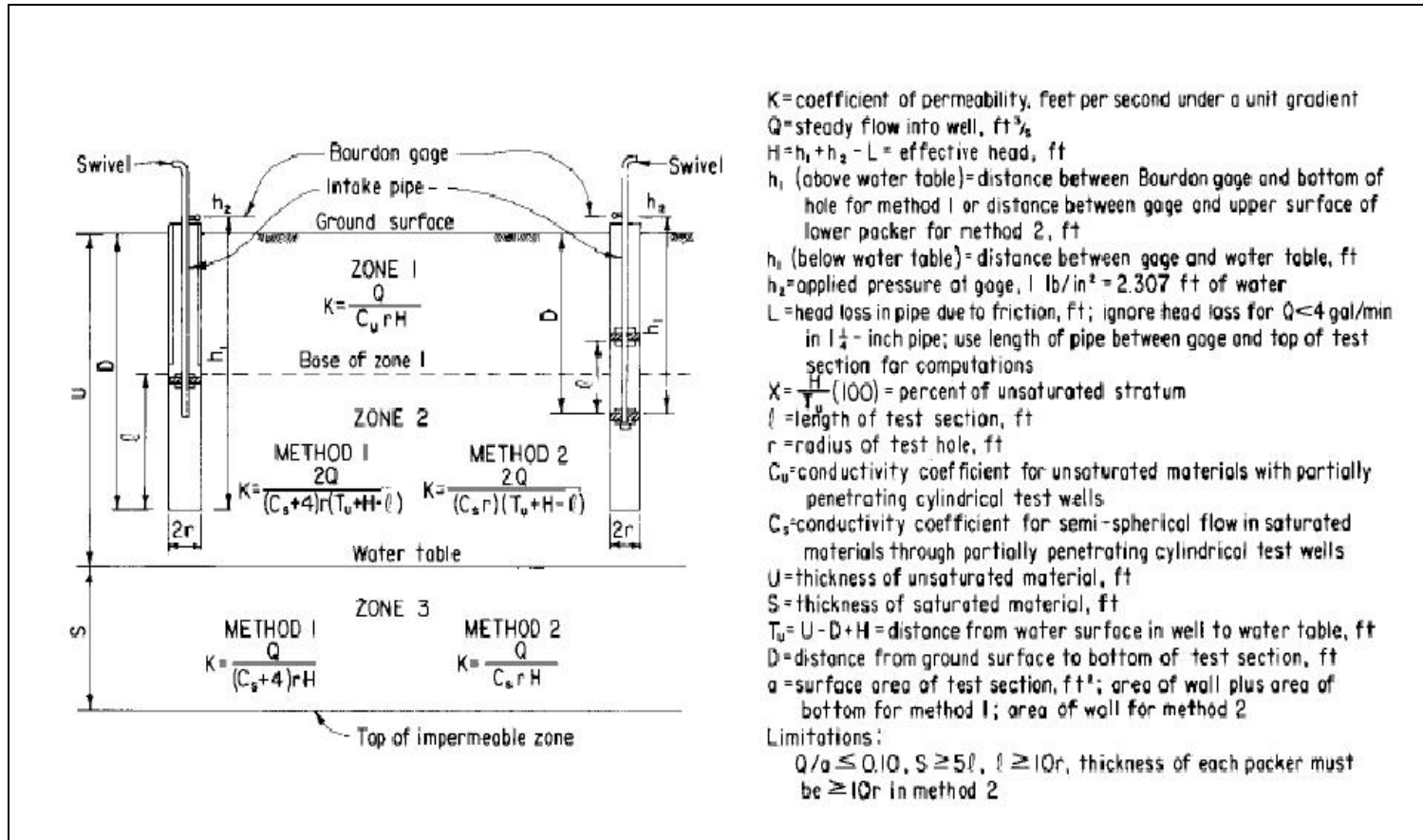

Figure 1. Illustration of Potential Packer Test Configurations, Solution Methods, and Explanation of Mathematical Symbols (modified after Bureau of Reclamation 1998, Figure 17-5)

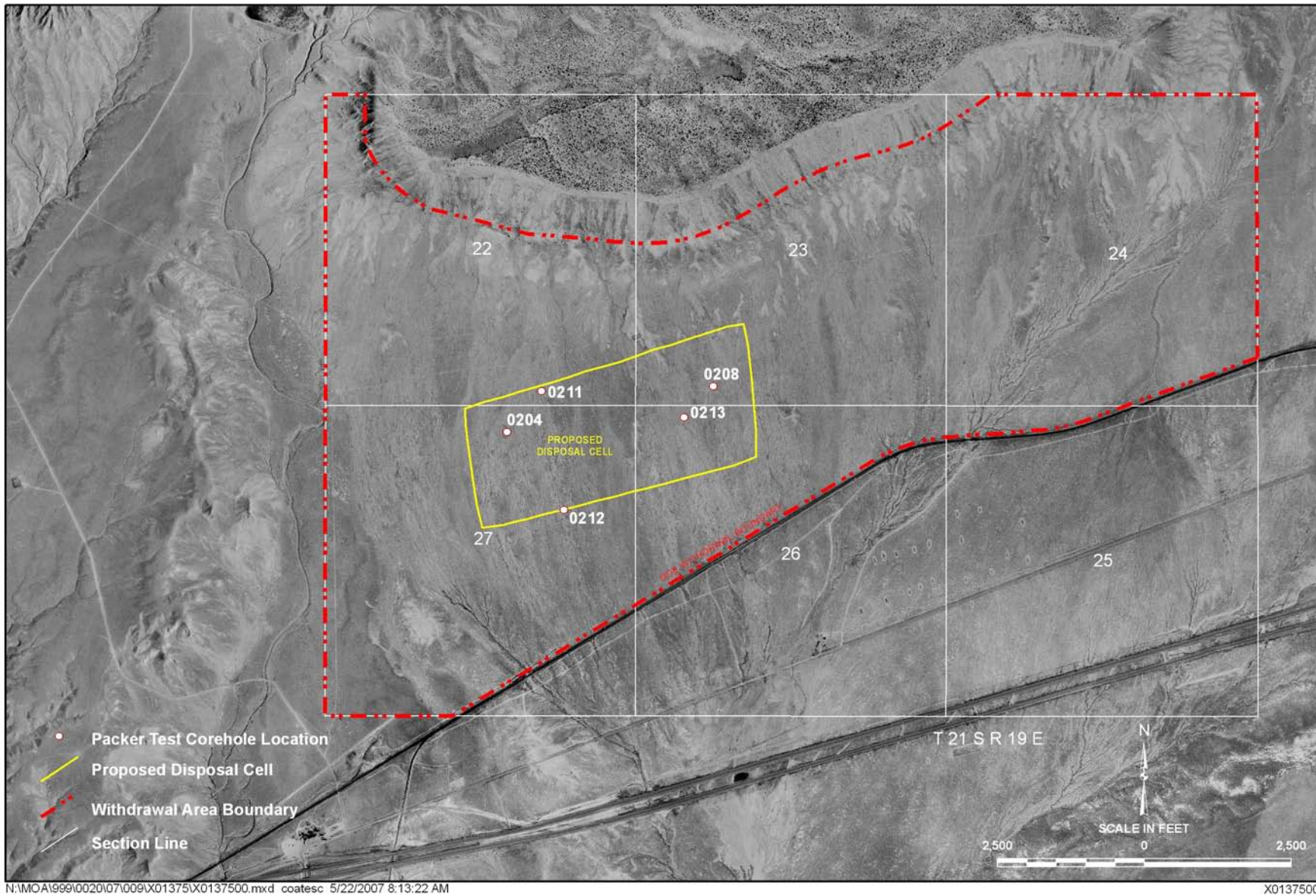

Figure 2. Packer Test Corehole Locations

Wireline Packer

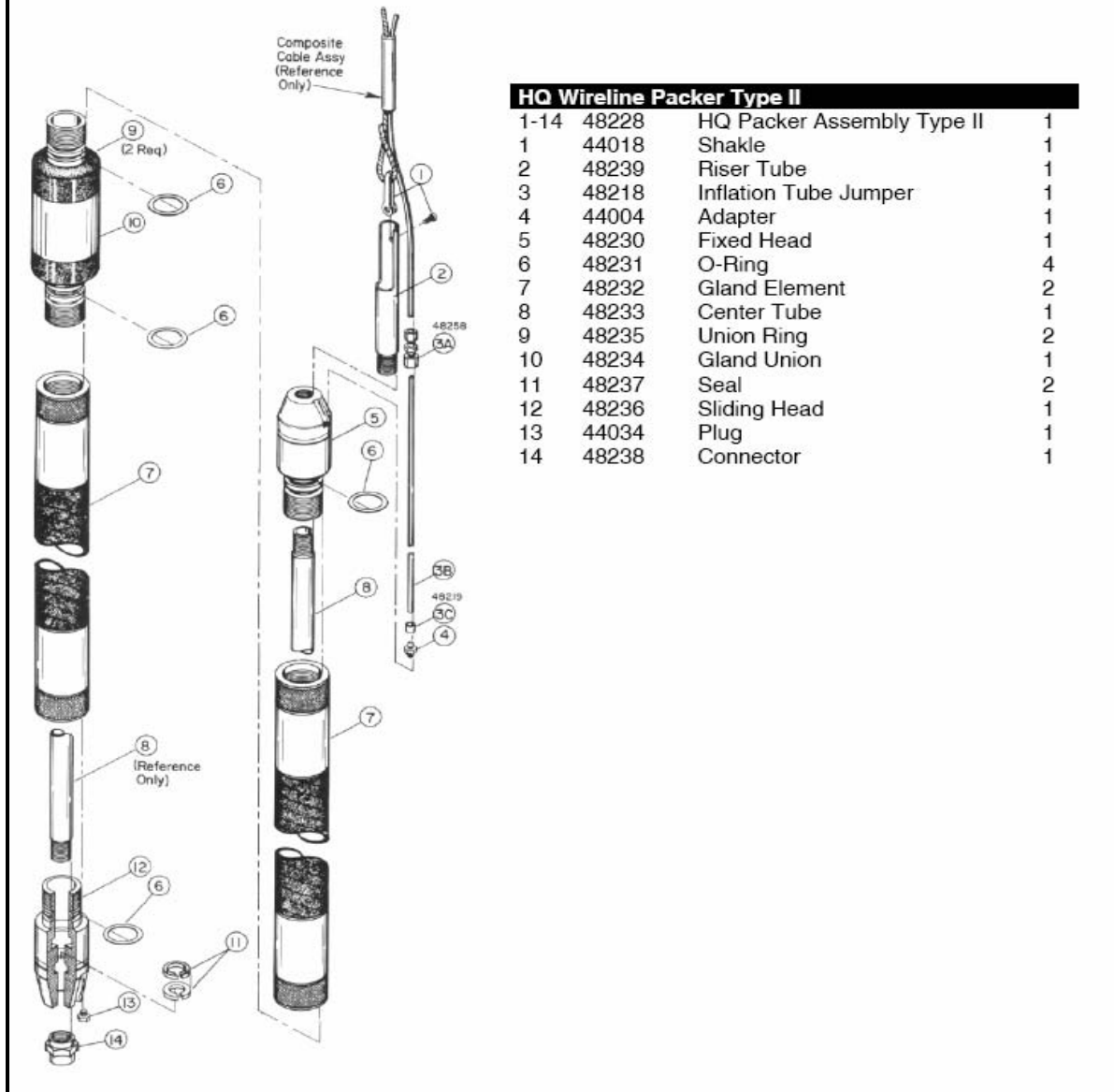

Figure 3. Schematic Diagram of Single Wire Line Packer System Used on the Crescent Junction Project

The dual packer tests were done in the deep coreholes and were intended to test representative sections of the competent Mancos Shale. The tests began in the deepest part of the corehole and proceeded upward until three depth intervals were tested. The test intervals were selected on the basis of visual observations of the rock core retrieved from the corehole, which indicated a stratigraphic contact probably exists between the Prairie Canyon and Blue Gate Members of the Mancos Shale at a depth of approximately 100 ft in corehole 0204 and 110 ft in corehole 0208.

Each test interval was 12 ft in length. Test intervals were chosen to straddle that contact and ascertain if any observable differences exist in the hydraulic conductivity of those units. A test interval was also chosen near the bottom of each corehole. The diameter of each corehole was nominally 3.9 inches. Water for coring and washing the selected test interval was obtained either from the Thompson Springs or the

Moab municipal water supply system. Each interval was tested at multiple gauge pressures ranging from 5 to 30 lb/in². Because the flows were very low or nonexistent, a test duration of up to 30 minutes was used whenever practicable. The dual-packer system was inflated to pressures ranging from 230 to 300 lb/in² prior to testing each interval.

Assumptions:

- Injected water flows directly into the test interval without short-circuiting through the packer seal.
- For flows exceeding 4 gallons per minute (gpm), friction losses through the drill pipe follow the Pressure Loss Curve provided by the subcontractor, Layne Geoconstruction.
- Solutions provided in the Manual (USBR 1998) are applicable to the field conditions at the Crescent Junction Disposal Site.
- The analysis methods presented in the Manual (USBR 1998) are equally valid both above and below the water table.

Calculations:

Calculations are attached in Appendix A. Table 1 provides a summary of the test results for this project.

Discussion:

Table 1 presents a summary of the packer test results. The horizontal hydraulic conductivity values range from 10⁻³ centimeters per second (cm/s) to less than 10⁻⁷ cm/s. The hydraulic conductivity of the weathered bedrock is approximately 4 orders of magnitude higher than the unweathered bedrock. Based on the packer tests, the relatively high hydraulic conductivity in the weathered Mancos Shale extends to a depth of at least 40 ft below ground surface. At a depth of 80 to 130 ft below land surface, the hydraulic conductivities are less than 10⁻⁷ cm/s. The transition between weathered and unweathered bedrock probably correlates to the fracture intensity. Optical televiewer logs prepared for this project suggest that the transition between weathered and unweathered bedrock occurs at a depth of approximately 50 to 60 ft below the surface.

Table 1. Summary of Field-Permeability "Packer" Test Results for the Crescent Junction Site

Test Interval: Hole ID @ Depth (ft)	Calculated Permeability (cm/s) @ Injection Pressure (lb/in ²)				
	Test 1	Test 2	Test 3	Test 4	Test 5
Dual-Packer Tests: Unweathered Mancos Shale[†]					
0204 @ 80 to 92	J 1.3 × 10 ⁻⁸ @ 10	3.9 × 10 ⁻⁷ @ 20	J 9.6 × 10 ⁻⁹ @ 30	6.6 × 10 ⁻⁷ @ 20	J 1.3 × 10 ⁻⁸ @ 10
0204 @ 110 to 122	J 7.5 × 10 ⁻⁹ @ 10	9.1 × 10 ⁻⁸ @ 20	4.2 × 10 ⁻⁷ @ 30	J 9.1 × 10 ⁻⁸ @ 20	J 7.5 × 10 ⁻⁹ @ 10
0204 @ 283 to 295	J 8.9 × 10 ⁻⁹ @ 5	1.2 × 10 ⁻⁶ @ 10	2.6 × 10 ⁻⁶ @ 20	J 1.1 × 10 ⁻⁸ @ 10	J 1.2 × 10 ⁻⁸ @ 5
0208 @ 90 to 102	J 6.0 × 10 ⁻⁹ @ 10	J 7.7 × 10 ⁻⁹ @ 20	J 2.2 × 10 ⁻⁹ @ 30	J 7.7 × 10 ⁻⁹ @ 20	J 6.0 × 10 ⁻⁹ @ 10
0208 @ 121 to 133	J 8.0 × 10 ⁻⁹ @ 10	J 1.4 × 10 ⁻⁸ @ 20	7.5 × 10 ⁻⁷ @ 30	J 1.4 × 10 ⁻⁸ @ 20	J 8.0 × 10 ⁻⁹ @ 10
0208 @ 282 to 294	6.3 × 10 ⁻⁷ @ 5	6.0 × 10 ⁻⁷ @ 10	J 6.0 × 10 ⁻⁹ @ 20	J 5.7 × 10 ⁻⁹ @ 10	2.1 × 10 ⁻⁷ @ 5
Single-Packer Tests: Weathered Mancos Shale[‡]					
0211 @ 20 to 30	1.4 × 10 ⁻³ @ 5	1.3 × 10 ⁻³ @ 5	1.7 × 10 ⁻³ @ 5		
0211 @ 30 to 40	1.4 × 10 ⁻³ @ 5				
0212 @ 20 to 30	1.6 × 10 ⁻³ @ 5	1.8 × 10 ⁻³ @ 10	2.0 × 10 ⁻³ @ 5		
0212 @ 30 to 40	2.5 × 10 ⁻³ @ 5	2.3 × 10 ⁻³ @ 10	2.5 × 10 ⁻³ @ 5		
0213 @ 20 to 30	2.4 × 10 ⁻³ @ 5	2.2 × 10 ⁻³ @ 10	2.2 × 10 ⁻³ @ 5		
0213 @ 30 to 40	2.3 × 10 ⁻³ @ 5	2.6 × 10 ⁻³ @ 10	2.5 × 10 ⁻³ @ 5		

Notes:

Gray fields indicate no additional data collected at that test interval.

J flag represents the quantitation limit for a no-flow test.

[†] Geometric mean of unweathered Mancos Shale: 3.5 × 10⁻⁸ cm/s

[‡] Geometric mean of weathered Mancos Shale: 2.0 × 10⁻³ cm/s

Conclusion and Recommendations:

Results from the packer tests illustrate that the hydraulic conductivity of the Mancos Shale at the Crescent Junction Disposal Site is much lower in the competent bedrock underlying the weathered interval that extends to at least 40 ft beneath the land surface. Below the weathered zone, the hydraulic conductivity of the Mancos Shale decreases by approximately 4 orders of magnitude.

Computer Source:

Not applicable

Appendix A

Copies of Packer Testing Raw-Data Sheets and Analysis Sheets

Packer-Test Record

Page 1 of 3

Project Name: Crescent Junction Characterization Date: 11/21/05

Field Representative: M. Kautsky Borehole No. 211 Total Depth: 30ft.

Depth to Water (TOC): ± 120 ft. Borehole Cleaned? Yes No Date: 11-21-05

Test Interval (BGL): from 20 to 30 ft. Swivel/Elbow Height (AGL) 5'

Conductor Pipe, Type and Size: HQ

Time	Gauge Pressure	Flow Meter Reading
12:17 ^{mm} 12:17	5 psi mm	34356
12:19	5 psi	34376
12:21	5 psi	34400 > 12 gpm
12:23	5 psi	34425 > 12½ gpm
12:24	5 psi	34440 > 15 gpm
12:25	5 psi	34456 > 16 gpm
12:28	5 psi	34504.5 > 16.2 gpm
12:29	5 psi	34527 > 22.5 "
12:30	5 psi	34546.5 > 19.5 "
^{mm} 12:32 12:31	5 psi	34568.5 > 22 "
12: 32 33	5 psi	34613 > 22.2
12:35	5 psi	34658.5 > 22.7

Packer-Test Record

Project Name: Crescent Junction Characterization Date: 11-21-05

Field Representative: M. Kautsky Borehole No. 211 Total Depth: 30 ft

Depth to Water (TOC): 12'± Borehole Cleaned? Yes No Date: _____

Test Interval (BGL): from 20 to 30 ft. Swivel/Elbow Height (AGL) 5 ft.

Conductor Pipe, Type and Size: HQ

Time	Gauge Pressure	Flow Meter Reading
<u>12:40</u>	<u>10 psi</u>	<u>34723</u>
<u>12:42</u>	<u>10 psi</u>	<u>34764</u> } 20 gpm
<u>12:43</u>	<u>10 psi</u>	<u>34790</u> } 26 gpm
<u>12:44</u>	<u>10 psi</u>	<u>448 34816</u> } 26 gpm
<u>12:45</u>	<u>10 psi</u>	<u>34842</u> } 26 gpm
<u>12:46</u>	<u>10 psi</u>	<u>34870</u> } 28 gpm
<u>12:48</u>	<u>10 psi</u>	<u>34923</u> } 26.5 gpm
<u>Ran out of water @ 12:48</u>		
<u>14:08</u>	<u>10 psi</u>	<u>35000</u> } 23.5 gpm
<u>14:09</u>	<u>10 psi</u>	<u>35023.5</u> } 22 gpm
<u>14:10</u>	<u>10 psi</u>	<u>35045.5</u> } 20.5 gpm
<u>14:11</u>	<u>10 psi</u>	<u>35066</u> } 21.5 gpm
<u>14:12</u>	<u>10 psi</u>	<u>35087.5</u> } 20.5 gpm
<u>14:13</u>	<u>10 psi</u>	<u>35108</u> } 22 gpm
<u>14:14</u>	<u>10 psi</u>	<u>35130</u> } 22 gpm
<u>14:15</u>	<u>10 psi</u>	<u>35152</u> } 22 gpm
<u>14:16</u>	<u>10 psi</u>	<u>35174</u> } 22 gpm

end of 10 psi test

Packer-Test Record

Page 3 of 3

Project Name: Crescent Junction Characterization Date: 11-21-05

Field Representative: M. Kautsky Borehole No. 211 Total Depth: 30

Depth to Water (TOC): 120 ± Borehole Cleaned? Yes No Date: 11-21-05

Test Interval (BGL): from 20 to 30 ft. Swivel/Elbow Height (AGL) 5 ft

Conductor Pipe, Type and Size: HQ / HX

Time	Gauge Pressure	Flow Meter Reading	Flow (gpm)
<u>14:19</u>	<u>5 psi</u>	<u>35235</u>	
<u>14:20</u>	<u>5 psi</u>	<u>35256</u>	> 21 gpm
<u>14:21</u>	<u>5 psi</u>	<u>35278</u>	> 22 "
<u>14:22</u>	<u>5 psi</u>	<u>35299</u>	> 21 gpm
<u>14:24</u>	<u>5 psi</u>	<u>35342</u>	> 21.5 gpm
<u>14:25</u>	<u>5 psi</u>	<u>35362.5</u>	> 20.5 gpm
<u>14:26</u>	<u>5 psi</u>	<u>35384</u>	> 21.5 gpm
<u>14:27</u>	<u>5 psi</u>	<u>35406</u>	> 22 gpm
<u>14:28</u>	<u>5 psi</u>	<u>35425</u>	> 19 gpm
<u>14:29</u>	<u>5 psi</u>	<u>35446</u>	> 21 gpm
		<u>35468</u>	> 22

Stoller

DATE: 1-23-06

JOB NAME: Crescent Junction

PREPARED: M. Kautsky

REVIEWED:

SHEET NO.: OF

PACKER TEST ANALYSES

BOREHOLE: 211

Depth: 20-30 ft

Pressure (h_2): 5psi (11.6 ft)

Unsaturated Zone Calculation:

Definitions:

 l = length of test section

$$T_u = U - D + H$$

 U = Thickness of Unsaturated Material D = distance from ground surface to bottom of test section

$$H = h_1 + h_2 - L$$

 L = head loss; ignore if $Q < 4$ gpm

$$X = \frac{H}{T_u} (100); \text{ percent unsaturated material}$$

Reference Figure 17-6 U.S. Bureau of Rec. Earth Manual

$$l = 10 \text{ ft}$$

$$T_u = U - D + H = 120 \text{ ft} - 30 \text{ ft} + 44.5 \text{ ft} = 134.5 \text{ ft}$$

$$\frac{T_u}{l} = \frac{134.5 \text{ ft}}{10 \text{ ft}} = \boxed{13.4}$$

$$H = h_1 + h_2 - L = 35 \text{ ft} + 11.6 \text{ ft} - 2.1 \text{ ft} = 44.5 \text{ ft}$$

$$X = \frac{H}{T_u} (100) = \frac{44.5 \text{ ft}}{134.5 \text{ ft}} (100) = \boxed{33}$$

WATER TESTING FOR PERMEABILITY

- Effective head, the difference in feet (m) between the elevation of the free water surface in the pipe and the elevation of the gauge plus the applied pressure. If a pressure transducer is used, the effective head in the test section is the difference in pressure before water is pumped into the test section and the pressure readings made during the test.

The following examples show some typical calculations using Methods 1 and 2 in the different zones shown in figure 17-5. Figure 17-6 shows the location of the zone 1 lower boundary for use in unsaturated materials.

Pressure permeability tests examples using Methods 1 and 2:

1-30-06

Borehole : 211
 Depth : 20-30 ft
 Pressure (h_2) : 11.6 ft
 (5 psi)

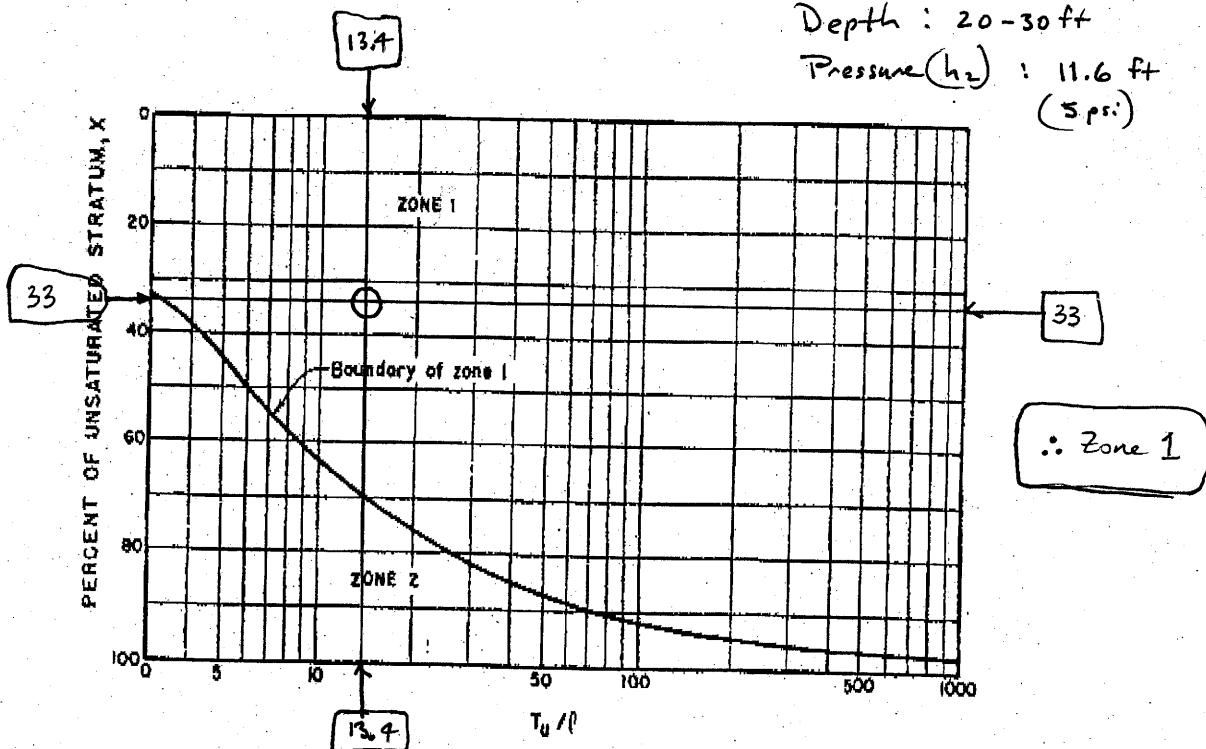

Figure 17-6.—Location of zone 1 lower boundary for use in unsaturated materials.

$$\frac{T_u}{e} = 13.4$$

$$X = 33$$

PRESSURE LOSS CURVE

Jul-25-05 04:21pm From-LAYNE CHRISTENSEN 9-V 8019741018 T-115 P.29/32 F-001

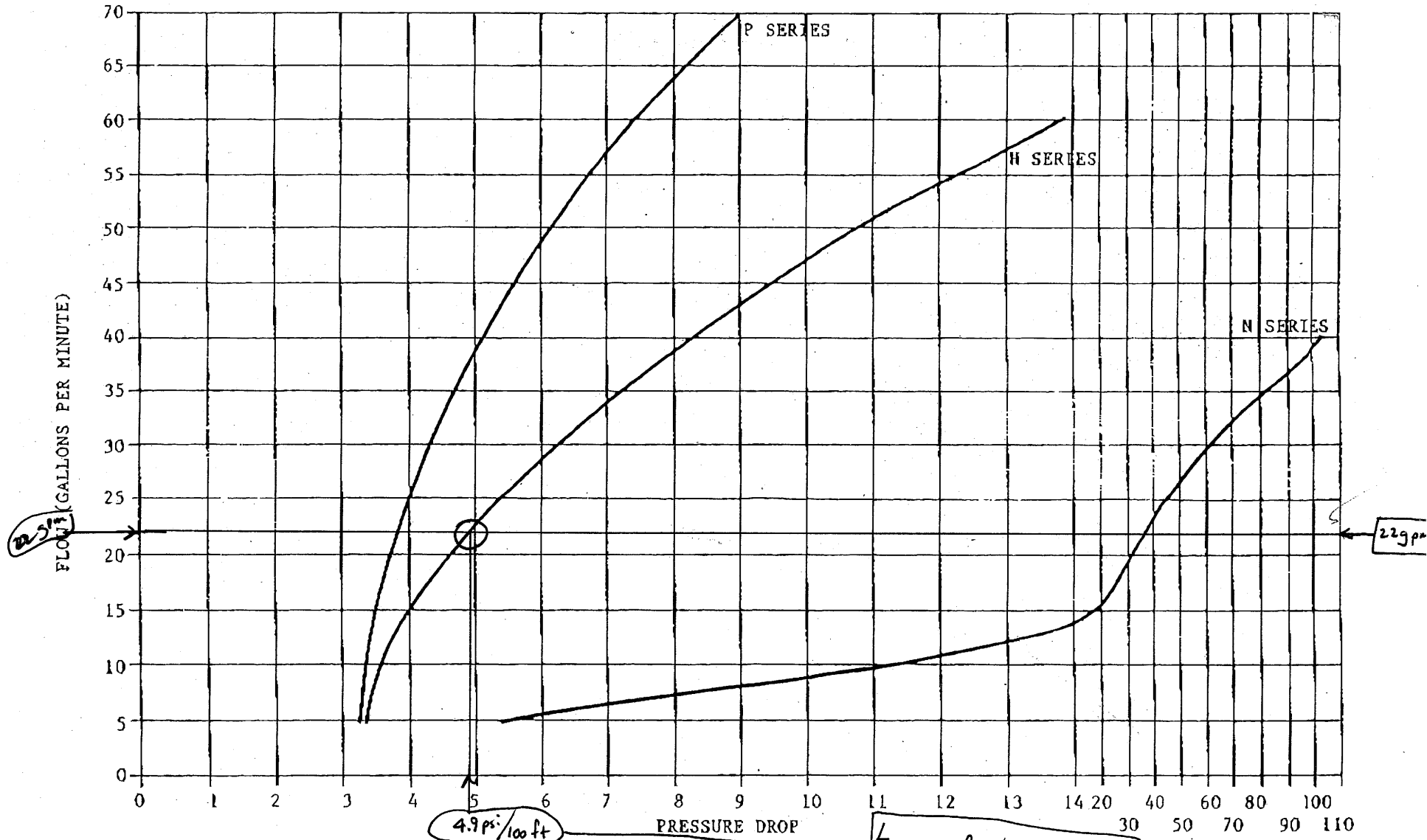

* TEST PERFORMED IN WATER TEMPERATURE OF 60°F (15.5°C)

* THIS CHART IS MEANT TO BE USED HAS A GUIDE ONLY. THE MEASUREMENTS WERE OBTAINED UNDER CONTROLLED LAB CONDITIONS AND ACTUAL FIELD CONDITIONS MAY VARY.

From: WIRELINE TYPE II service manual, Beart Longyear.

Borehole: 211
 Depth: 20-30 ft
 Pressure: 11.6 ft.
 (5 psi)

Stoller

PACKER TEST SET-UP SHEET

Zone 1

JOB NO: _____ DATE: 1-30-06

JOB NAME: Crescent Junction Site

PREPARED: Mark Kautsky REVIEWED: _____

Borehole 211

SHEET NO: 1 OF _____

Depth 20-30 ft
pressure (h₂) = 5 psi

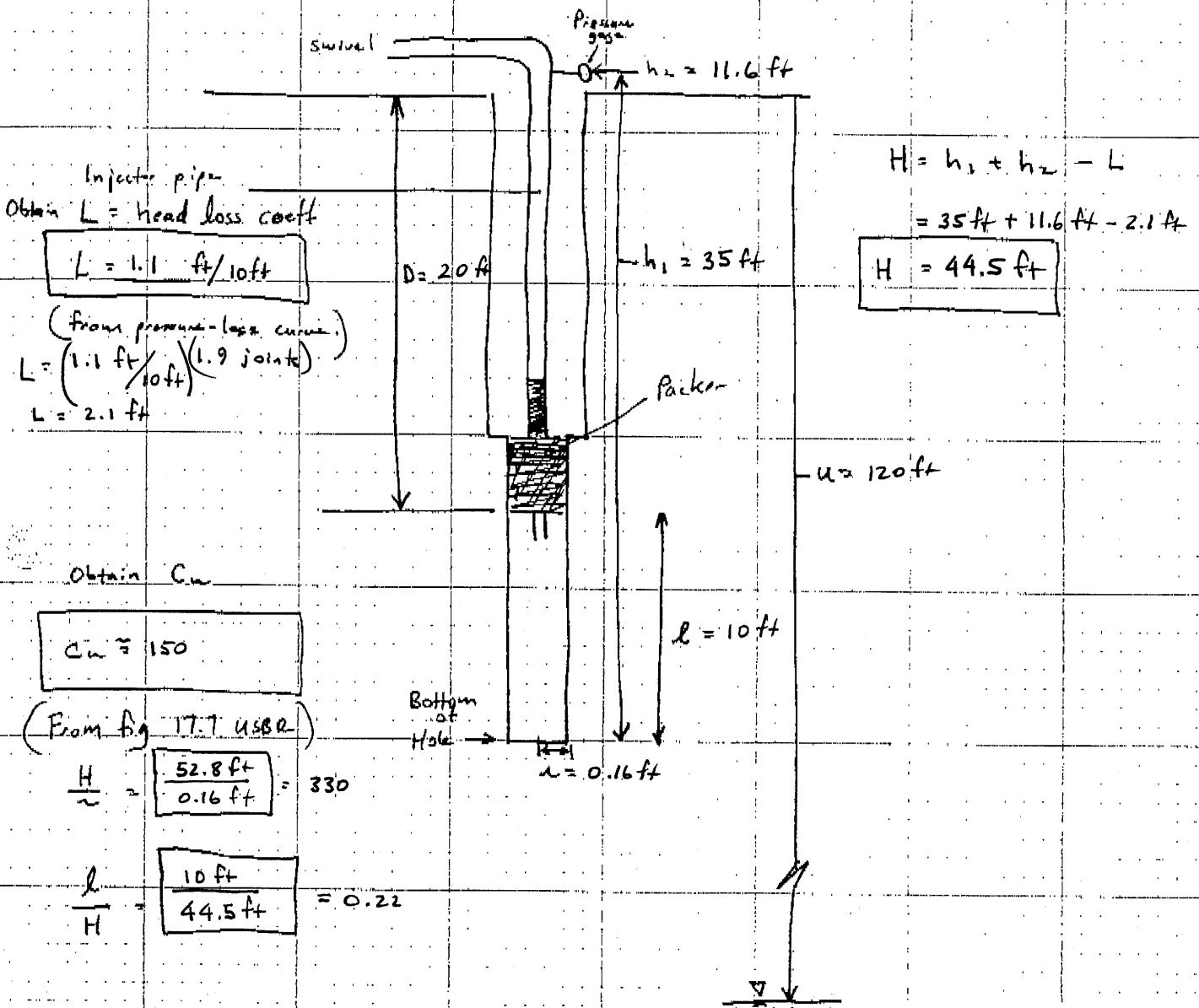

Injector pipe
Obtain L = head loss coeff
 $L = 1.1 \text{ ft}/10\text{ft}$
(from pressure-loss curve)
 $L = (1.1 \text{ ft}/10\text{ft})(1.9 \text{ joints})$
 $L = 2.1 \text{ ft}$

$$H = h_1 + h_2 - L$$

$$= 35 \text{ ft} + 11.6 \text{ ft} - 2.1 \text{ ft}$$

$$H = 44.5 \text{ ft}$$

Obtain C_w
 $C_w = 150$
(From Fig. 17.7 USBR)
 $\frac{H}{r} = \frac{52.8 \text{ ft}}{0.16 \text{ ft}} = 330$

$$\frac{l}{H} = \frac{10 \text{ ft}}{44.5 \text{ ft}} = 0.22$$

Calculate K:
Method 1,
Zone 1,
USBR

$$K = \frac{Q}{C_w r H} = \frac{\left(\frac{22 \text{ gal}}{\text{min}}\right) \left(\frac{1440 \text{ min}}{\text{d}}\right) \left(\frac{\text{ft}^3}{7.48 \text{ gal}}\right)}{(150) (0.16 \text{ ft}) (44.5 \text{ ft})}$$

$$K = 4.0 \text{ ft/day}$$

$$K = 1.4 \times 10^{-3} \text{ cm/sec}$$

WATER TESTING FOR PERMEABILITY

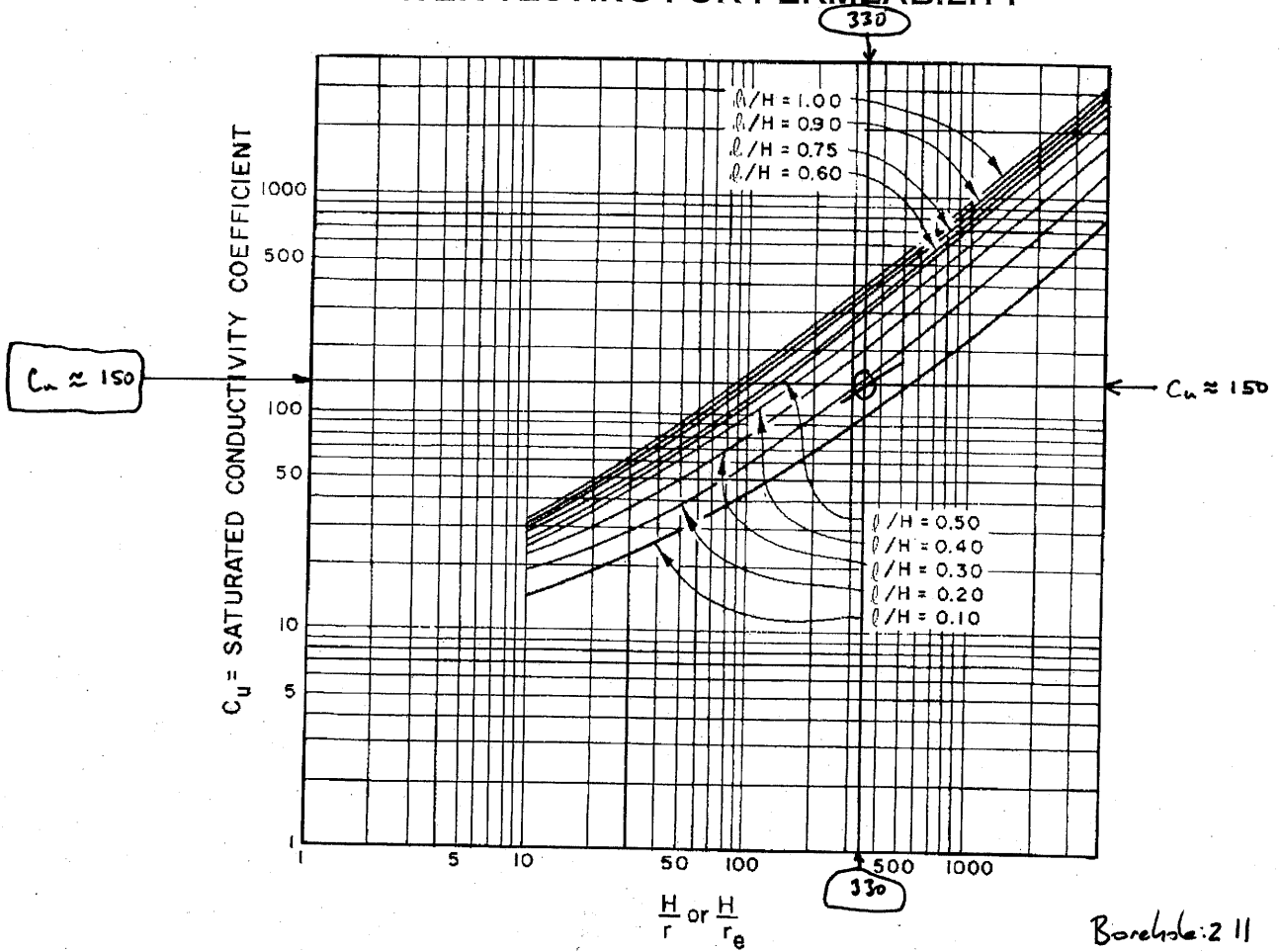

Figure 17-7.—Conductivity coefficients for permeability determination in unsaturated materials with partially penetrating cylindrical test wells.

Borehole: 2 1/2
 Depth: 20-30 ft
 Pressure: 11.6 ft

Zone 2

Given: U , ℓ , r , h_2 , Q , and L are as given in example 1, $D = 65$ feet, and $h_1 = 72$ feet

If the distance from the gauge to the bottom of the intake pipe is 62 feet, the total L is $(6.2)(0.76) = 4.7$ feet.

$$H = 72 + 57.8 - 4.7 = 125.1 \text{ feet}$$

Stoller

LOCATION: Crescent Junction

PREPARED: M. Kautsky

REVIEWED:

SHEET NO. OF

PACKER TEST ANALYSES

BOREHOLE : 211

Depth : 20-30 ft

 Pressure (h_2) : 23.1 ft (10 psi)

Unsaturated Zone Calculation:

 Definitions: l = length of test section

$$T_u = U - D + H$$

 U = Thickness of Unsaturated Material

 D = distance from ground surface to bottom of test section

$$H = h_1 + h_2 - L$$

 L = head loss ; ignore if $Q < 4 \text{ gpm}$
 $X = \frac{H}{T_u} (100)$; percent unsaturated material

Reference Figure 17-6 U.S. Bureau of Rec. Earth Manual

$$l = 10 \text{ ft}$$

$$T_u = U - D + H = 120 \text{ ft} - 30 \text{ ft} + 55.3 \text{ ft} = \boxed{145.3}$$

$$\frac{T_u}{l} = \frac{145.3 \text{ ft}}{10 \text{ ft}} = \boxed{14.5}$$

$$H = h_1 + h_2 - L = \boxed{54.9 \text{ ft}}$$

$$X = \frac{H}{T_u} (100) = \frac{54.9 \text{ ft}}{145.3 \text{ ft}} (100) = \boxed{38}$$

WATER TESTING FOR PERMEABILITY

- Effective head, the difference in feet (m) between the elevation of the free water surface in the pipe and the elevation of the gauge plus the applied pressure. If a pressure transducer is used, the effective head in the test section is the difference in pressure before water is pumped into the test section and the pressure readings made during the test.

The following examples show some typical calculations using Methods 1 and 2 in the different zones shown in figure 17-5. Figure 17-6 shows the location of the zone 1 lower boundary for use in unsaturated materials.

Pressure permeability tests examples using Methods 1 and 2:

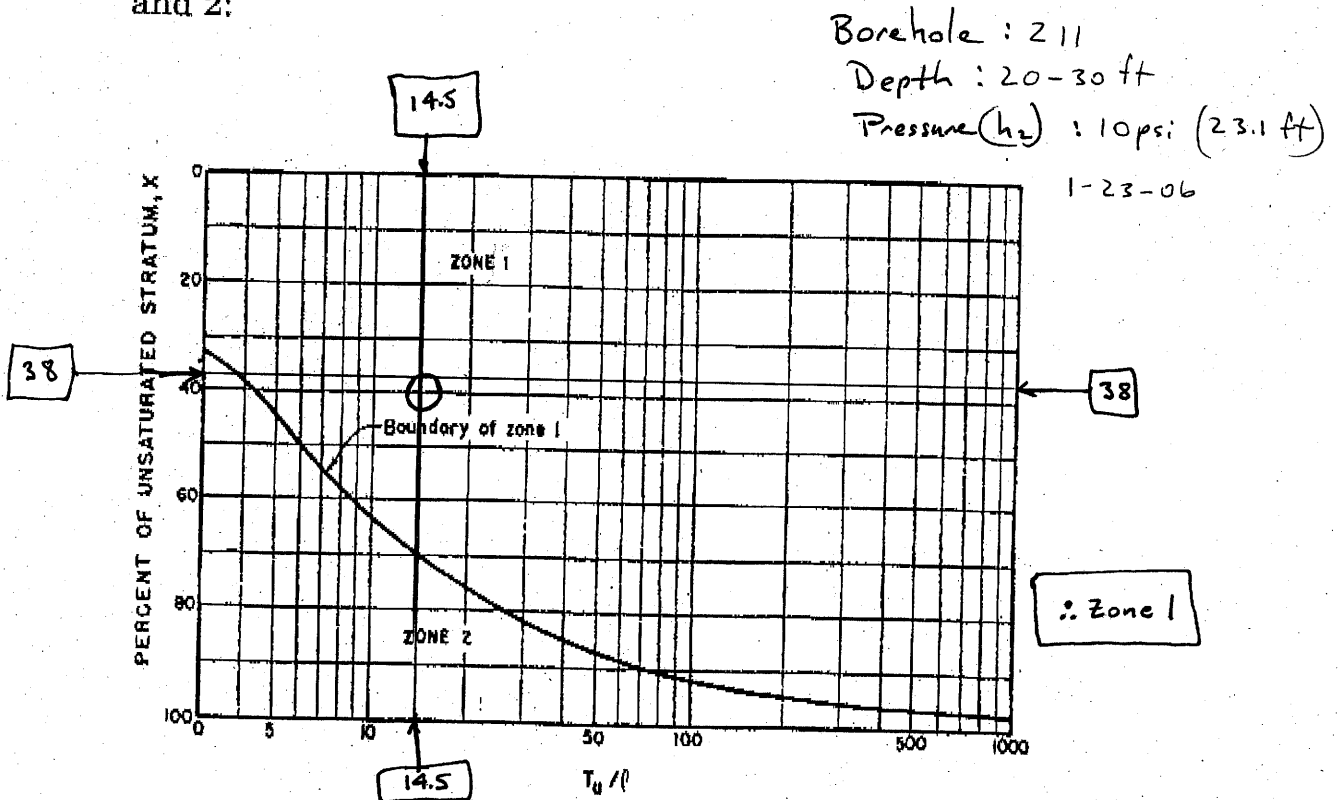

Figure 17-6.—Location of zone 1 lower boundary for use in unsaturated materials.

$$\frac{T_u}{l} = 14.5$$

$$X = 38$$

Stoller

PACKER TEST SET-UP SHEET

Zone 1

JOB NO: _____ DATE: 1-30-06
 JOB NAME: Crescent Junction Site
 PREPARED: Mark Kautsky REVIEWED: _____
 SHEET NO: 1 OF 1
 Borehole 211
 Depth 20-30 ft
 Pressure 10 psi

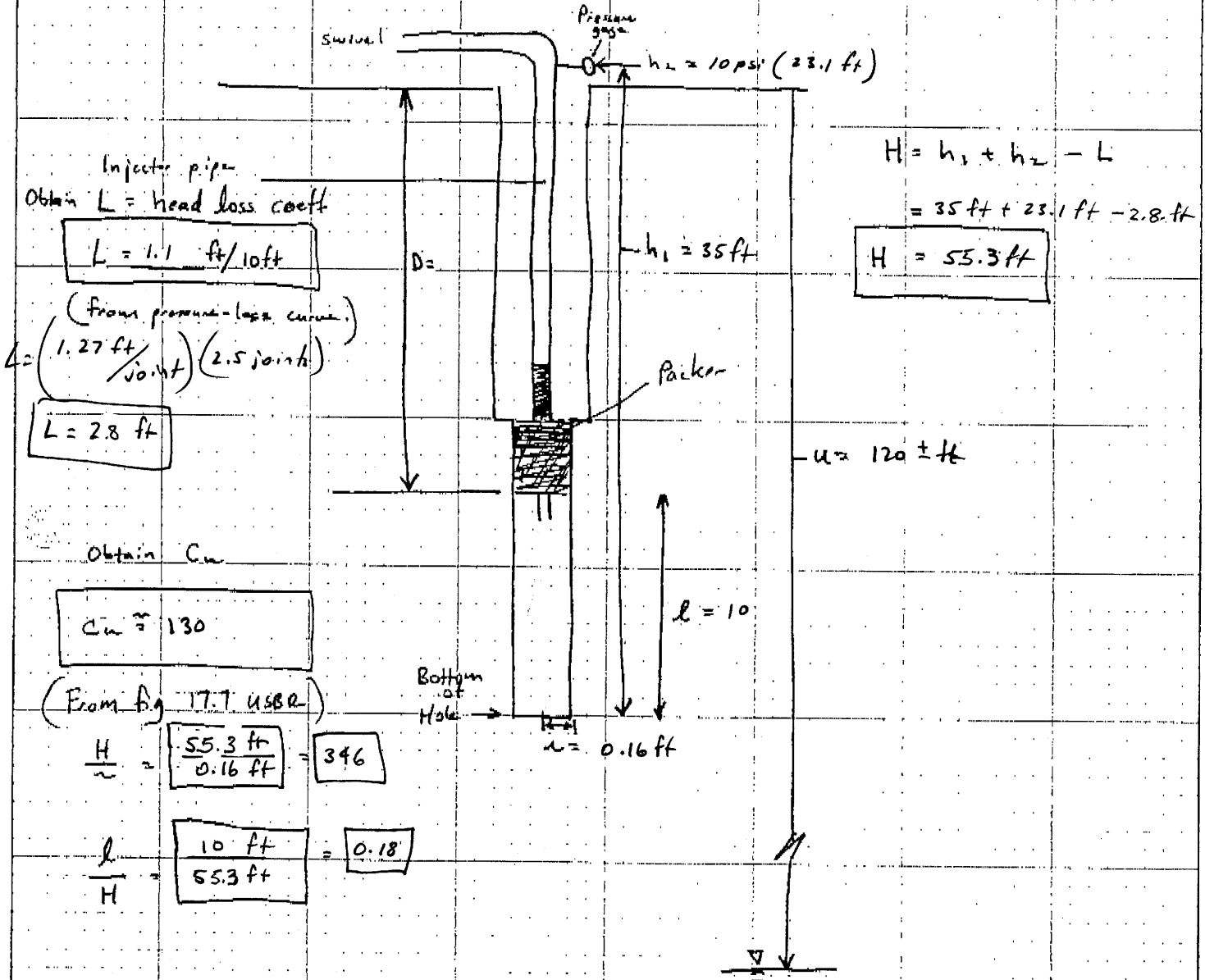

Injector pipe
 Obtain L = head loss coeff
 $L = 1.1 \text{ ft/10ft}$
 (from pressure-loss curve)
 $L = (1.27 \text{ ft/joint}) (2.5 \text{ joints})$
 $L = 2.8 \text{ ft}$

$$H = h_1 + h_2 - L$$

$$= 35 \text{ ft} + 23.1 \text{ ft} - 2.8 \text{ ft}$$

$$H = 55.3 \text{ ft}$$

Obtain C_w
 $C_w \approx 130$

(From Eq 17.7 USBR)

$$\frac{H}{l} = \frac{55.3 \text{ ft}}{0.16 \text{ ft}} = 346$$

$$\frac{l}{H} = \frac{10 \text{ ft}}{55.3 \text{ ft}} = 0.18$$

Calculate K :
 Method 1,
 Zone 1,
 USBR

$$K = \frac{Q}{C_w l H} = \frac{(22 \text{ gal/min}) (1440 \text{ min/d}) (1 \text{ ft}^3 / 7.48 \text{ gal})}{(130) (0.16 \text{ ft}) (55.3 \text{ ft})}$$

$$K = 3.7 \text{ ft/day}$$

$$K = 1.3 \times 10^{-3} \text{ cm/sec}$$

PRESSURE LOSS CURVE

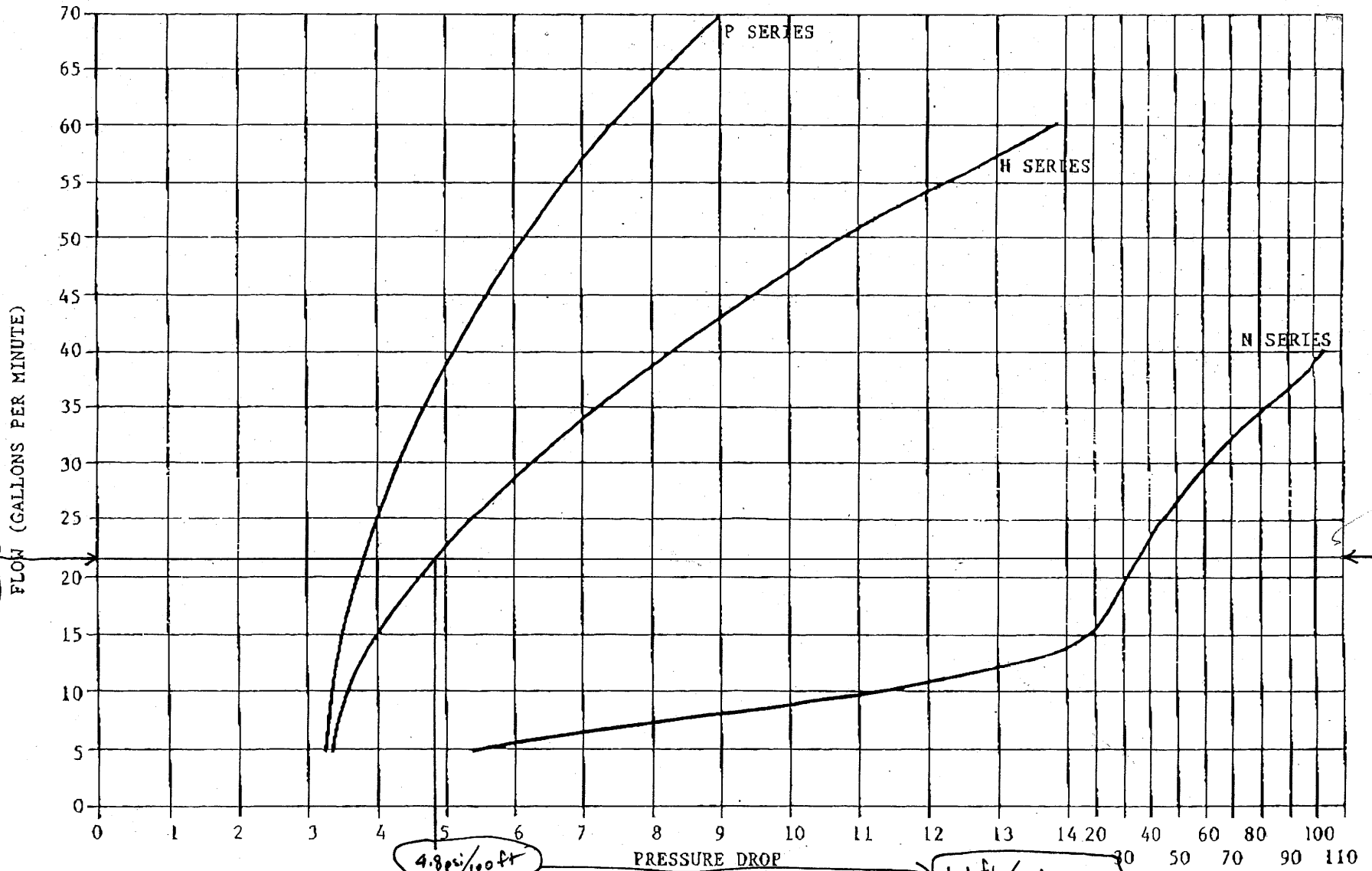

* TEST PERFORMED IN WATER TEMPERATURE OF 60°F (15.5°C)

* THIS CHART IS MEANT TO BE USED AS A GUIDE ONLY. THE MEASUREMENTS WERE OBTAINED UNDER CONTROLLED LAB CONDITIONS AND ACTUAL FIELD CONDITIONS MAY VARY.

From: WIRELINE TYPE II service manual, Boat Longyear.

Boat Longyear 211
Depth 20-30 ft
Pressure 10 psi
1-30-06

WATER TESTING FOR PERMEABILITY

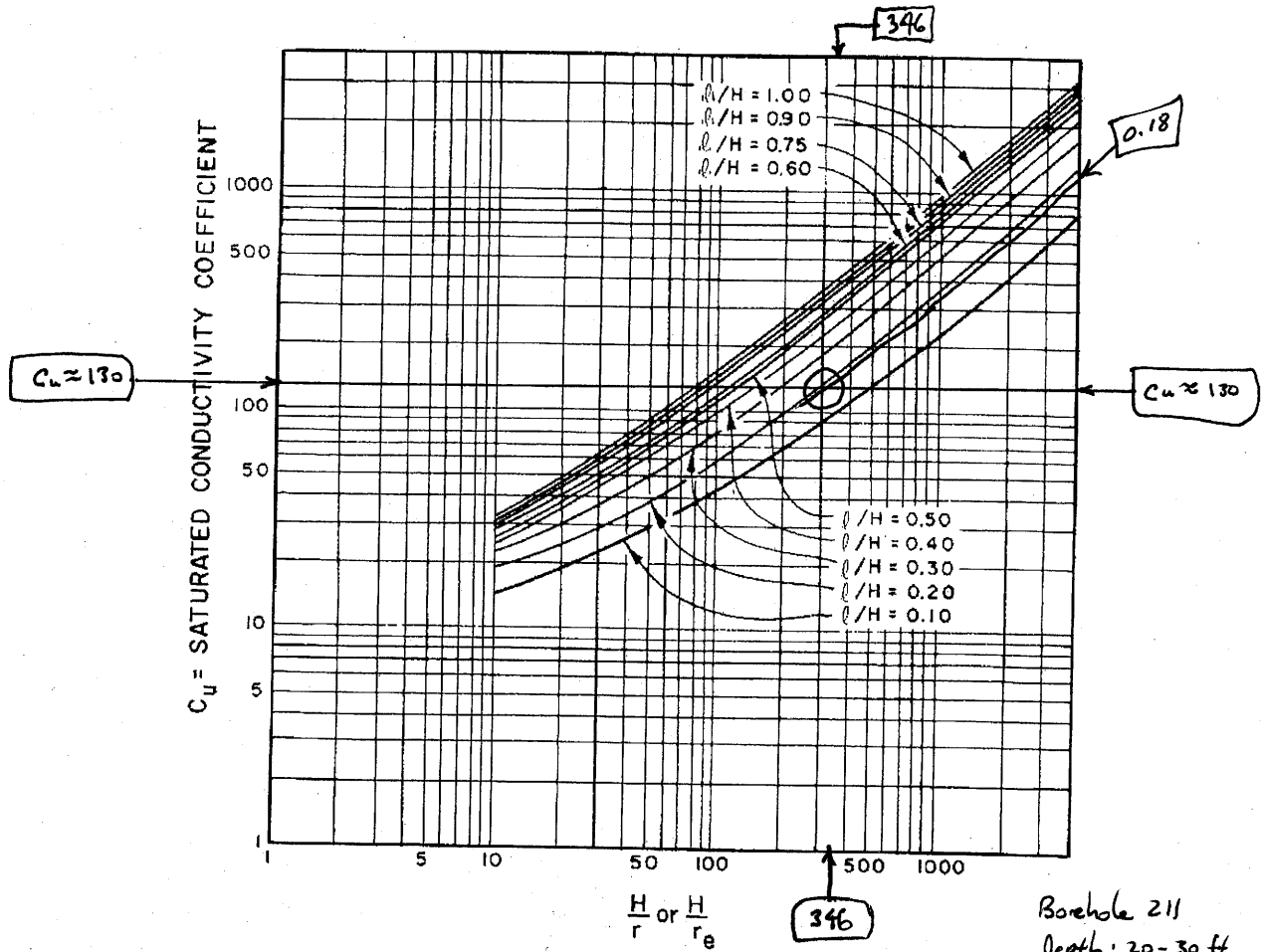

Figure 17-7.—Conductivity coefficients for permeability determination in unsaturated materials with partially penetrating cylindrical test wells.

Borehole 211
 Depth: 20-30 ft
 pressure: 10 psi
 1-30-06

Zone 2

Given: U , l , r , h_2 , Q , and L are as given in example 1, $D = 65$ feet, and $h_1 = 72$ feet

If the distance from the gauge to the bottom of the intake pipe is 62 feet, the total L is $(6.2)(0.76) = 4.7$ feet.

$$H = 72 + 57.8 - 4.7 = 125.1 \text{ feet}$$

Stoller

PROJECT

DATE 1-23-06

JOB NAME Crescent Junction

PREPARED: M. Kautsky

REVIEWED:

SHEET NO. OF

PACKER TEST ANALYSES

BOREHOLE: 211

Depth: 20-30 ft

Pressure (h_2): 5 psi (retest)

Unsaturated Zone Calculation:

Definitions:

 L = length of test section $T_u = U - D + H$ U = Thickness of Unsaturated Material D = distance from ground surface to bottom of test section $H = h_1 + h_2 - L$ L = head loss; ignore if $Q < 4$ gpm $X = \frac{H}{T_u} (100)$; percent unsaturated material

Reference Figure 17-6 U.S. Bureau of Rec. Earth Manual

$$L = 10$$

$$T_u = U - D + H = (120 - 30 + 43.8) \text{ ft} = 134 \text{ ft}$$

$$\frac{T_u}{L} = \frac{134 \text{ ft}}{10 \text{ ft}} = \boxed{13.4}$$

$$H = h_1 + h_2 - L = 43.8 \text{ ft}$$

$$X = \frac{H}{T_u} (100) = \frac{43.8 \text{ ft}}{134 \text{ ft}} = \boxed{0.33} = \boxed{33\%}$$

PRESSURE LOSS CURVE

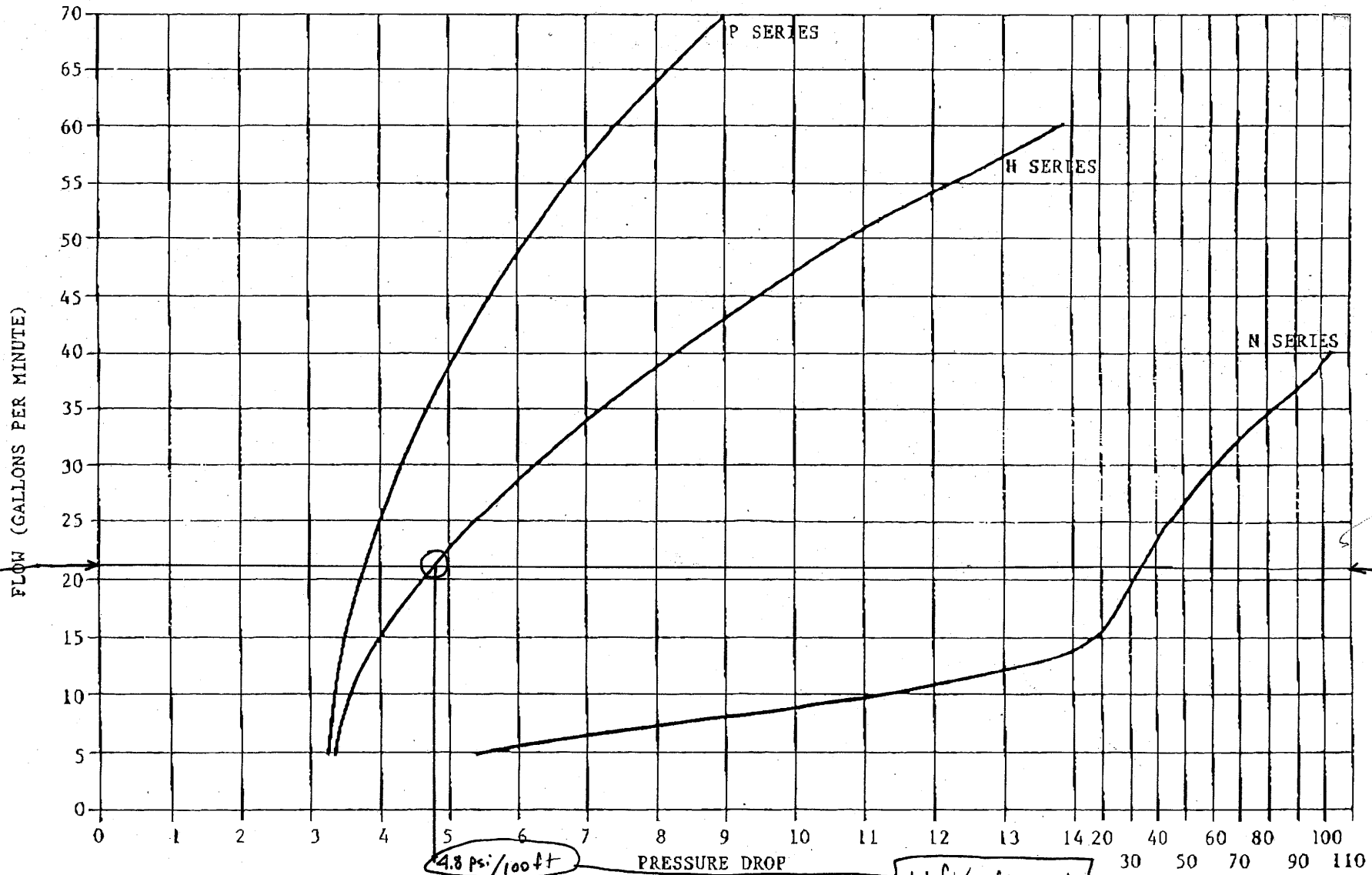

* TEST PERFORMED IN WATER TEMPERATURE OF 60°F (15.5°C)

* THIS CHART IS MEANT TO BE USED HAS A GUIDE ONLY. THE MEASUREMENTS WERE OBTAINED UNDER CONTROLLED LAB CONDITIONS AND ACTUAL FIELD CONDITIONS MAY VARY.

From: WIRELINE TYPE II service manual, Bost Longyear

Boston 211
 April 20-30-74
 pressure 5 psi (retest)
 1-30-06

WATER TESTING FOR PERMEABILITY

Borehole 211
Depth 20-30 ft
Pressure: 5 psi (retes A)
1-30-06

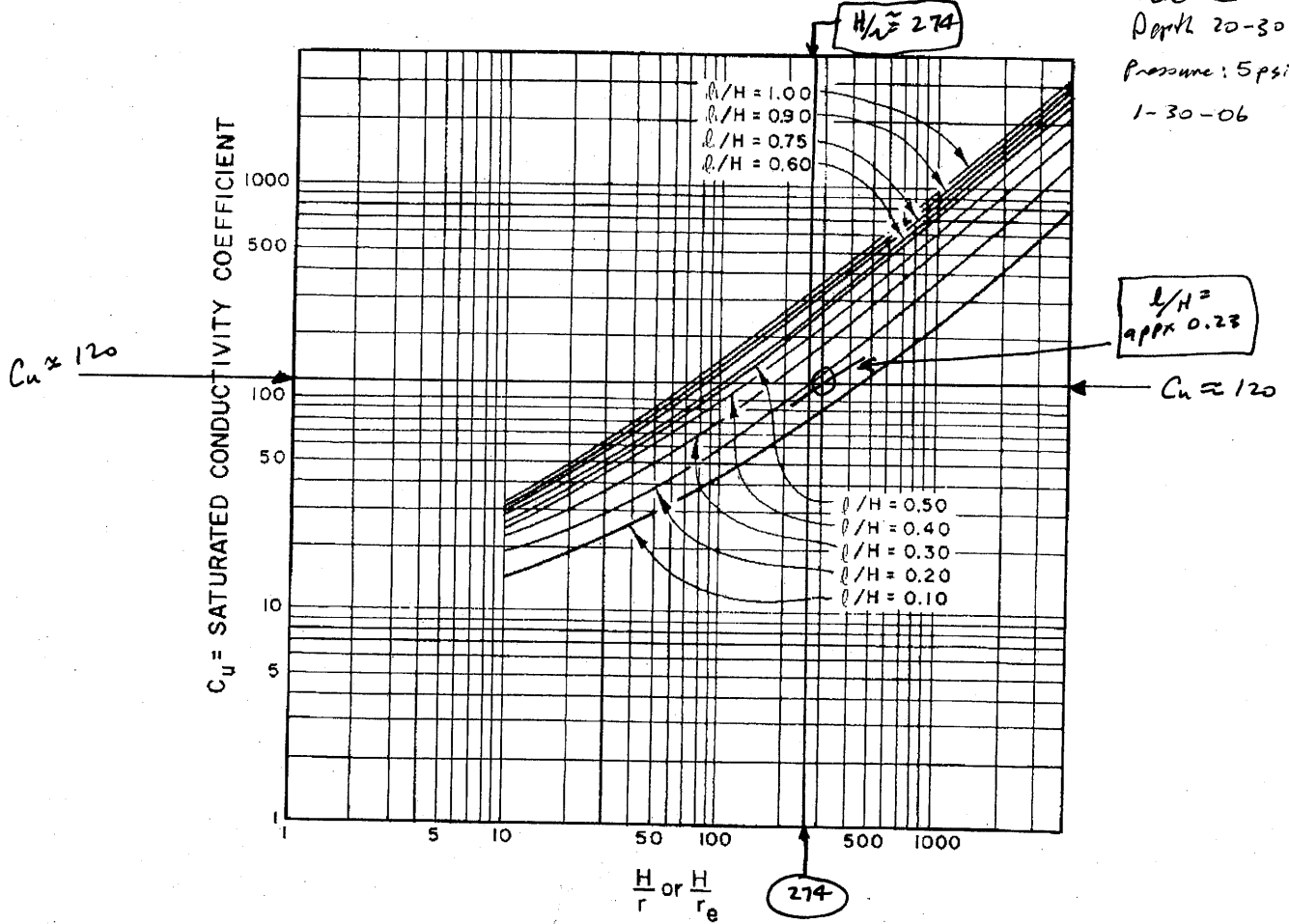

Figure 17-7.—Conductivity coefficients for permeability determination in unsaturated materials with partially penetrating cylindrical test wells.

Zone 2

Given: U , l , r , h_2 , Q , and L are as given in example 1, $D = 65$ feet, and $h_1 = 72$ feet

If the distance from the gauge to the bottom of the intake pipe is 62 feet, the total L is $(6.2)(0.76) = 4.7$ feet.

$$H = 72 + 57.8 - 4.7 = 125.1 \text{ feet}$$

WATER TESTING FOR PERMEABILITY

- Effective head, the difference in feet (m) between the elevation of the free water surface in the pipe and the elevation of the gauge plus the applied pressure. If a pressure transducer is used, the effective head in the test section is the difference in pressure before water is pumped into the test section and the pressure readings made during the test.

The following examples show some typical calculations using Methods 1 and 2 in the different zones shown in figure 17-5. Figure 17-6 shows the location of the zone 1 lower boundary for use in unsaturated materials.

Pressure permeability tests examples using Methods 1 and 2:

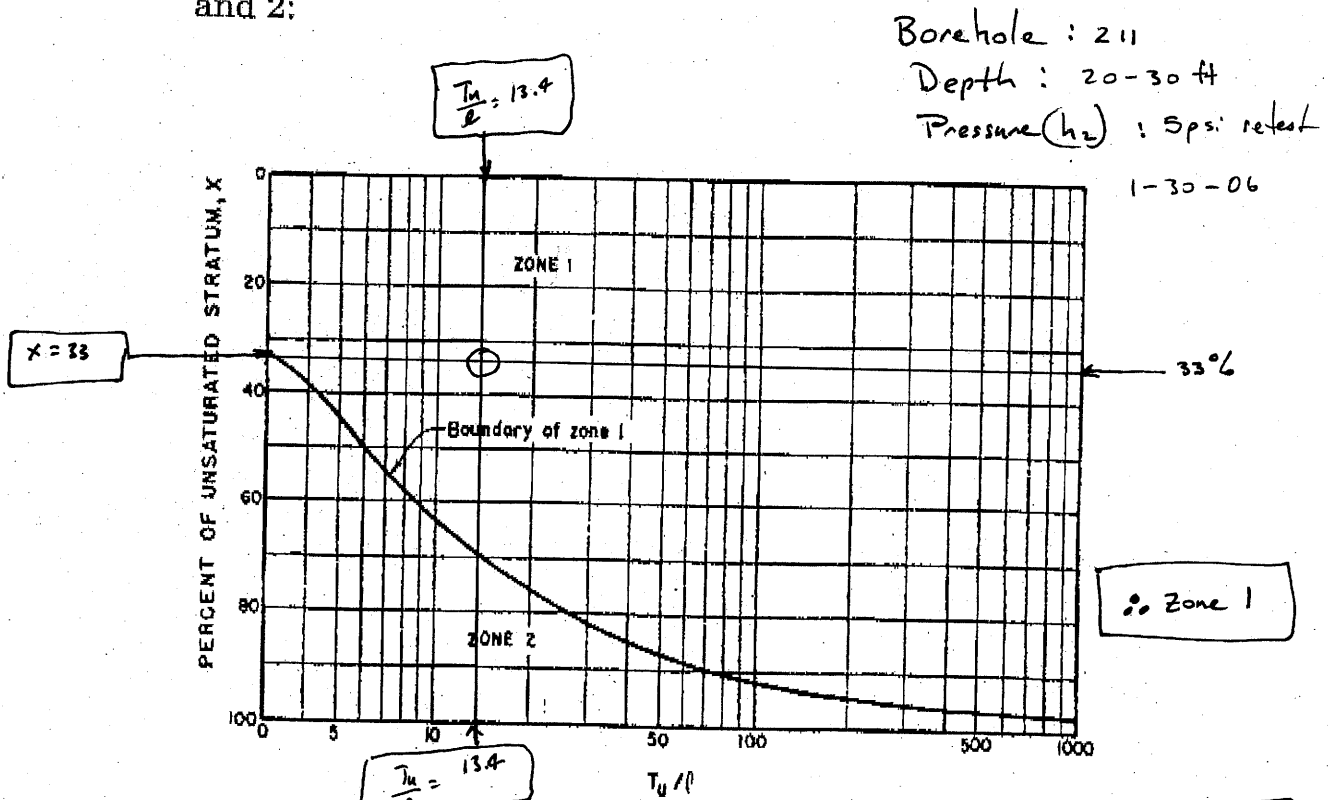

Figure 17-6.—Location of zone 1 lower boundary for use in unsaturated materials.

$$\frac{T_u}{l} = 13.4$$

$$X = 33$$

Stoller

PACKER TEST SET-UP SHEET Zone 1

JOB NO: _____ DATE: 1-30-06
 JOB NAME: Crescent Junction Site
 PREPARED: Mark Kautsky REVIEWED: _____
 SHEET NO: 1 OF _____

Borehole: 211
 Depth: 20-30 ft
 Pressure: 5 psi (retent)

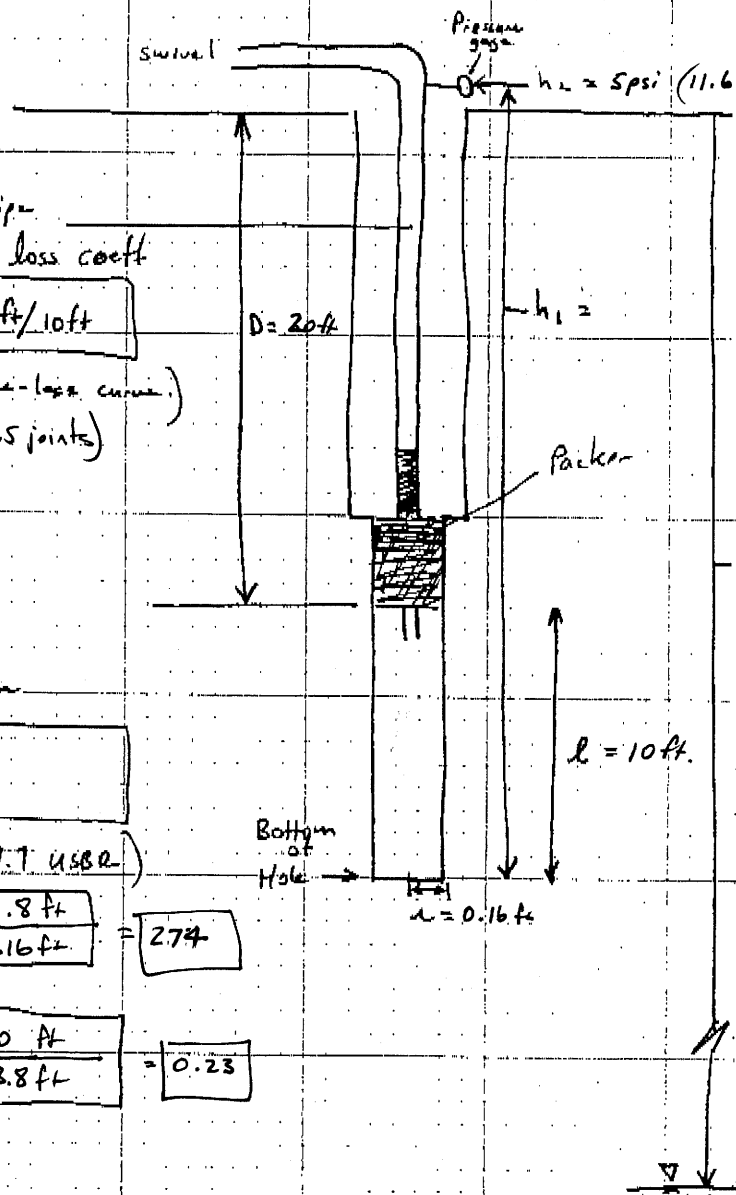

Injector pipe
 Obtain L = head loss coeff
 $L = 1.1 \text{ ft}/10\text{ft}$

(From pressure-loss curve)
 $L = \left(\frac{1.1 \text{ ft}}{\text{joint}}\right) (2.5 \text{ joints})$
 $L = 2.8 \text{ ft}$

$$H = h_1 + h_2 - L$$

$$= (35 + 11.6 - 2.8) \text{ ft}$$

$$H = 43.8 \text{ ft}$$

Obtain C_u

$$C_u \cong 120$$

(From Fig. 17.7 USBR)

$$\frac{H}{r} = \frac{43.8 \text{ ft}}{0.16 \text{ ft}} = 274$$

$$\frac{l}{H} = \frac{10 \text{ ft}}{43.8 \text{ ft}} = 0.23$$

Calculate K :

Method 1,
 Zone 1,
 USBR

$$K = \frac{Q}{C_u r H} = \frac{\left(\frac{21 \text{ gal}}{\text{min}}\right) \left(\frac{1440 \text{ min}}{\text{day}}\right) \left(\frac{1 \text{ ft}^3}{7.48 \text{ gal}}\right)}{(120) (0.16 \text{ ft}) (43.8 \text{ ft})}$$

$$K = 4.8 \text{ ft/d}$$

$$K = 1.7 \times 10^{-3} \text{ cm/s}$$

Packer-Test Record

Page 1 of 1

Project Name: Crescent Junction Characterization Date: 11-22-05

Field Representative: Mark Kautsky Borehole No. 211 Total Depth: 40 ft

Depth to Water (TOC): 120 ± Borehole Cleaned? Yes No Date: 11-22-05

Test Interval (BGL): from 30 to 40 ft. Swivel/Elbow Height (AGL) 5 ft

Conductor Pipe, Type and Size: HX pipe / Aack Board Packers in AGL to 100 psi
wireline Type II

Time	Gauge Pressure	Flow Meter Reading	Flow (gpm)
09:05	5 PSF	35515	
09:06	5 PSF	35527.5	> 12.5 gpm
09:07	5 PSF	35543.5	> 16
09:08	5 PSF	35560.5	> 17
09:09	5 PSF	35581.5	> 21
09:10	5 PSF	35605.5	> 24
09:11	5 PSF	35630.5	> 25
09:12	5 PSF	35656	> 25.5
09:13	5 PSF	35680.5	> 24.5
09:14	5 PSF	35707	> 26.5
09:15	5 PSF	35733	> 26
09:16	5 PSF	35759	> 26
09:17	5 PSF	35785	> 26

Stoller

DATE 1-23-06

JOB NO. 145 Crescent Junction

PREPARED BY M. Kaetzky

REVIEWED:

SHEET NO. OF

PACKER TEST ANALYSES

BOREHOLE : 211

Depth : 30-40 ft

Pressure (h_2) : 5 psi 11.6 ft

Unsaturated Zone Calculation:

Definitions : l = length of test section

$$T_u = U - D + H$$

 U = Thickness of Unsaturated Material D = distance from ground surface to bottom of test section

$$H = h_1 + h_2 - L$$

 L = head loss ; ignore if $Q < 4 \text{ gpm}$

$$X = \frac{H}{T_u} (100) ; \text{ percent unsaturated material}$$

Reference Figure 17-6 U.S. Bureau of Rec. Earth Manual

$$l = 10 \text{ ft}$$

$$T_u = U - D + H = 120 - 30 + 52.1 = 142.1 \text{ ft}$$

$$\frac{T_u}{l} = \frac{142.1 \text{ ft}}{10 \text{ ft}} = \boxed{14.2}$$

$$H = h_1 + h_2 - L = 52.1 \text{ ft}$$

$$X = \frac{H}{T_u} (100) = \frac{52.1 \text{ ft}}{142.1 \text{ ft}} (100) = \boxed{37 \%}$$

WATER TESTING FOR PERMEABILITY

- Effective head, the difference in feet (m) between the elevation of the free water surface in the pipe and the elevation of the gauge plus the applied pressure. If a pressure transducer is used, the effective head in the test section is the difference in pressure before water is pumped into the test section and the pressure readings made during the test.

The following examples show some typical calculations using Methods 1 and 2 in the different zones shown in figure 17-5. Figure 17-6 shows the location of the zone 1 lower boundary for use in unsaturated materials.

Pressure permeability tests examples using Methods 1 and 2:

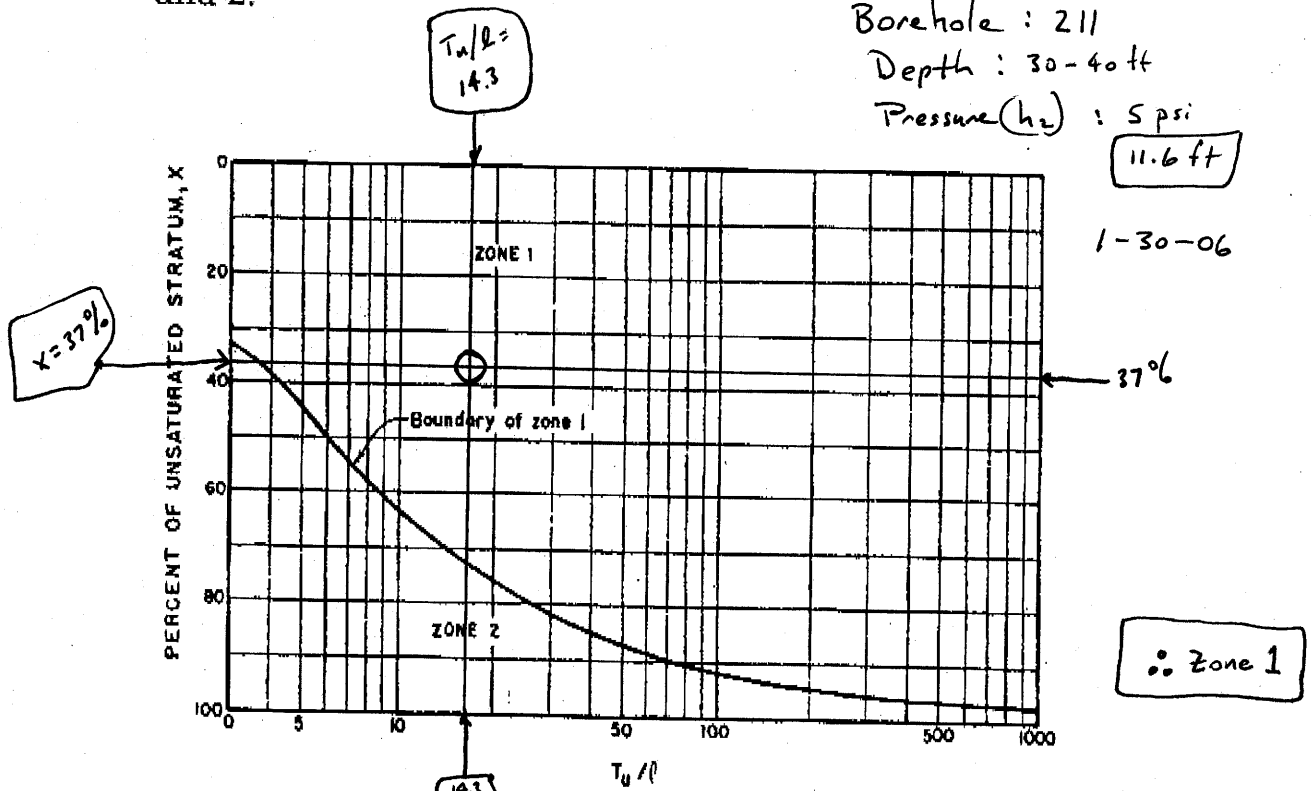

Figure 17-6.—Location of zone 1 lower boundary for use in unsaturated materials.

$$\frac{T_u}{l} = \boxed{14.3}$$

$$X = \boxed{37\%}$$

PRESSURE LOSS CURVE

Borehole 211
 Depth 30-40 ft
 P = 5 psi

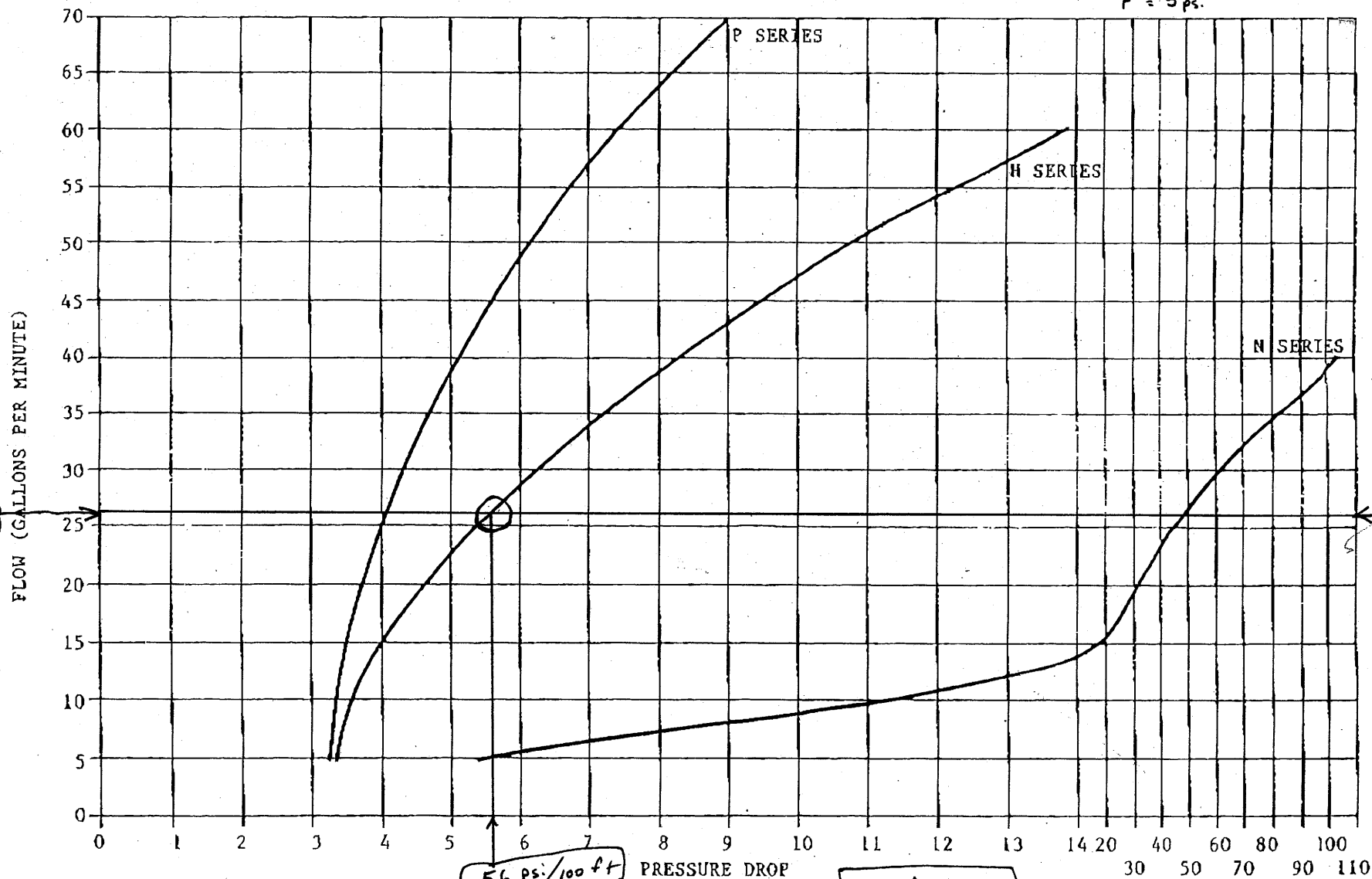

* TEST PERFORMED IN WATER TEMPERATURE OF 60°F (15.5°C)

* THIS CHART IS MEANT TO BE USED HAS A GUIDE ONLY. THE MEASUREMENTS WERE OBTAINED UNDER CONTROLLED LAB CONDITIONS AND ACTUAL FIELD CONDITIONS MAY VARY.

From: WIRELINE TYPE II service manual, Boat Longyear.

Borehole 211
 Depth: 30-40 ft.
 Pressure: 5 psi
 1-30-06

cc-v
 8019741018
 T-115 P.28/32 F-001
 From-LAYNE CHRISTENSEN
 Jul-25-05 04:21pm

26

26

5.6 psi/100 ft PRESSURE DROP = 1.29 ft/joint

Stoller

PACKER TEST SET-UP SHEET Zone 1

JOB NO.: _____ DATE: 1-30-06
 JOB NAME: Crescent Junction Site
 PREPARED: Mark Kautsky REVIEWED: _____
 SHEET NO.: 1 OF _____
 Corehole 211
 Depth 30-40 ft
 pressure: 5 psi

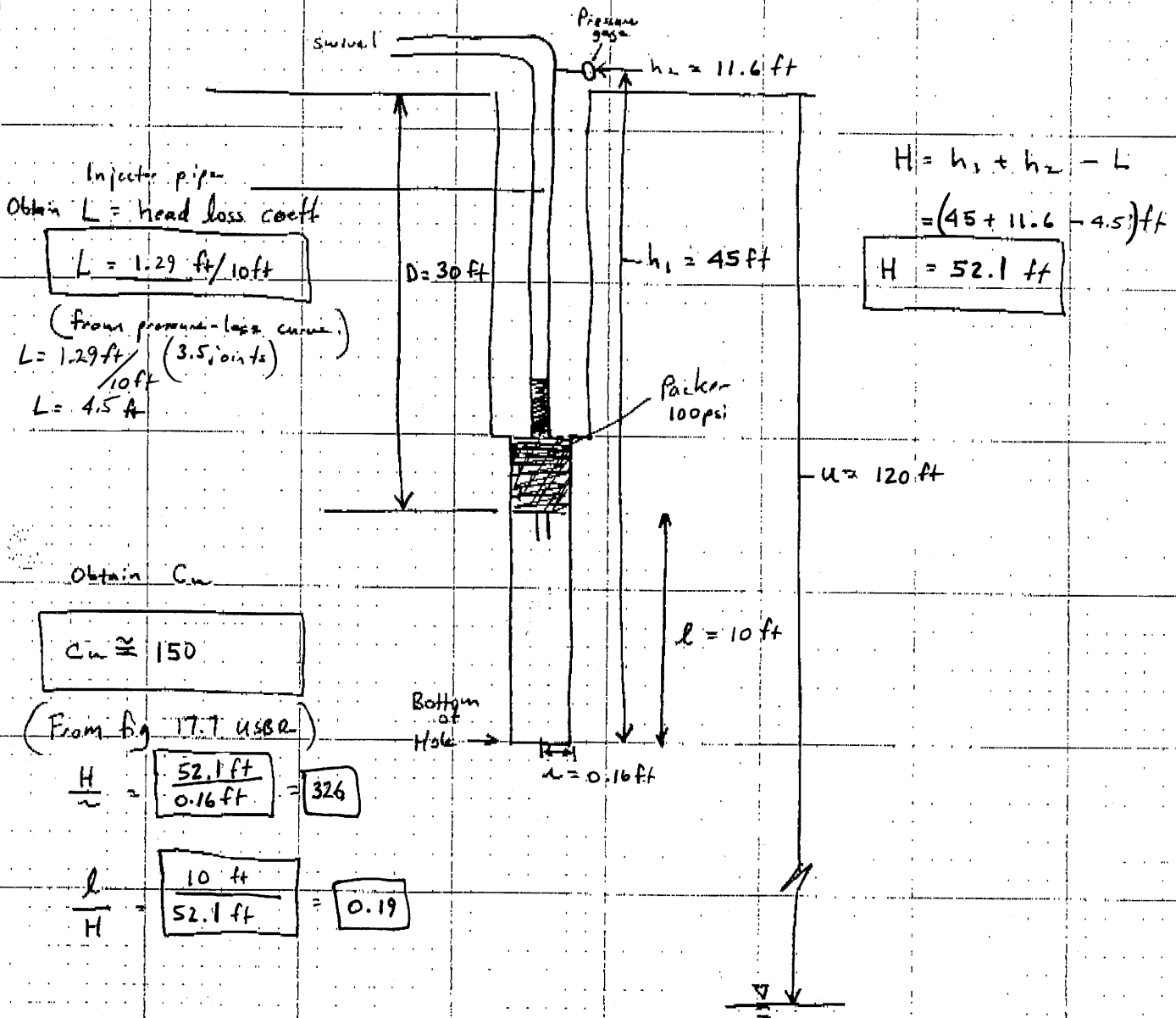

Injector pipe -
 Obtain L = head loss coeff

$$L = 1.29 \text{ ft}/10\text{ft}$$

(From pressure-loss curve.)
 $L = 1.29 \text{ ft}/10\text{ft}$ (3.5 joints)
 $L = 4.5 \text{ ft}$

$$H = h_1 + h_2 - L$$

$$= (45 + 11.6 - 4.5) \text{ ft}$$

$$H = 52.1 \text{ ft}$$

Obtain C_w

$$C_w \approx 150$$

(From Fig 17.7 USBR)

$$\frac{H}{r} = \frac{52.1 \text{ ft}}{0.16 \text{ ft}} = 326$$

$$\frac{l}{H} = \frac{10 \text{ ft}}{52.1 \text{ ft}} = 0.19$$

Calculate K :

Method 1,
 Zone 1,
 USBR

$$K = \frac{Q}{C_w r H} = \frac{\left(\frac{26 \text{ gal}}{\text{min}}\right) \left(\frac{1440 \text{ min}}{d}\right) \left(\frac{1 \text{ ft}^3}{7.48 \text{ gal}}\right)}{(150) (0.16 \text{ ft}) (52.1 \text{ ft})}$$

$$K = 4.0 \text{ ft/d}$$

$$K = 1.4 \times 10^{-3} \text{ cm/sec}$$

WATER TESTING FOR PERMEABILITY

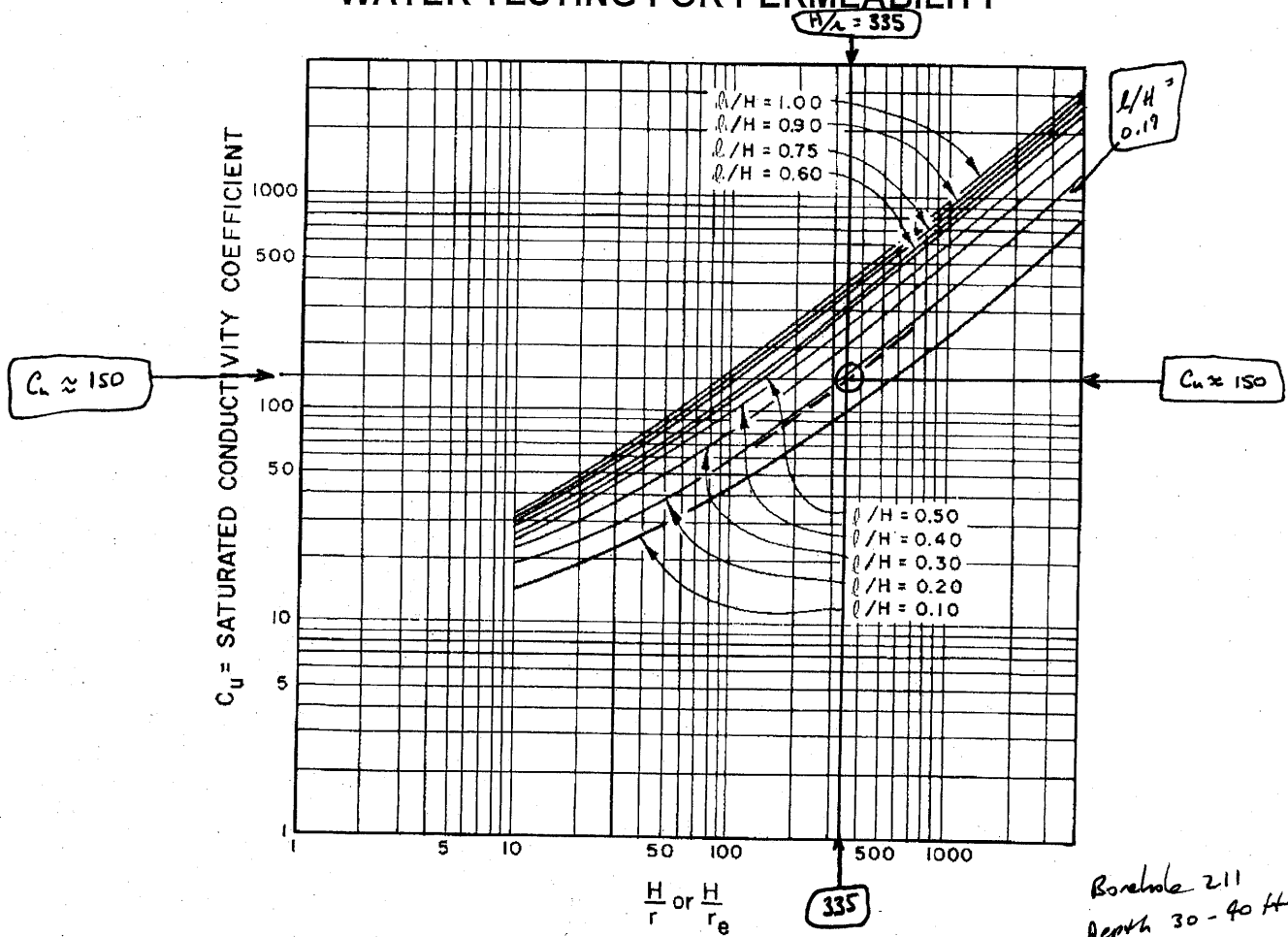

Figure 17-7.—Conductivity coefficients for permeability determination in unsaturated materials with partially penetrating cylindrical test wells.

Borehole 211
Depth 30-40 ft
Pressure 11.6 ft
1-30-06

Zone 2

Given: U , l , r , h_2 , Q , and L are as given in example 1, $D = 65$ feet, and $h_1 = 72$ feet

If the distance from the gauge to the bottom of the intake pipe is 62 feet, the total L is $(6.2)(0.76) = 4.7$ feet.

$$H = 72 + 57.8 - 4.7 = 125.1 \text{ feet}$$

Stoller

RECORD COPY

established 1959

Packer-Test Record

Page 1 of 3

Project Name: Crescent Junction Characterizat. Date: 11-23-05

Field Representative: M. Kautsky Borehole No. 212 Total Depth: 30 ft

Depth to Water (TOC): 120± Borehole Cleaned? Yes No Date: 11-23-05

Test Interval (BGL): from 20 to 30 ft. Swivel/Elbow Height (AGL) 5

Conductor Pipe, Type and Size: Hx

Time	Gauge Pressure	Flow Meter Reading	<i>flow (gpm)</i>
<u>08:25</u>	<u>5 PSF</u>	<u>35864</u>	
<u>08:26</u>	<u>5 PSF</u>	<u>35884</u>	→ 20
<u>08:27</u>	<u>5 PSF</u>	<u>35904</u>	→ 20
<u>08:28</u>	<u>5 PSF</u>	<u>35924</u>	→ 20
<u>08:29</u>	<u>5 PSF</u>	<u>35945</u>	→ 21
<u>08:30</u>	<u>5 PSF</u>	<u>35966</u>	→ 21
<u>08:31</u>	<u>5 PSF</u>	<u>35986</u>	→ 20
<u>08:32</u>	<u>5 PSF</u>	<u>36007</u>	→ 21
<u>08:33</u>	<u>5 PSF</u>	<u>36029</u>	→ 22
<u>08:34</u>	<u>5 PSF</u>	<u>36051</u>	→ 22
<u>08:35</u>	<u>5 PSF</u>	<u>36073</u>	→ 22
<u>08:36</u>	<u>5 PSF</u>	<u>36096</u>	→ 23
<u>08:37</u>	<u>5 PSF</u>	<u>36118</u>	→ 22
<u>08:38</u>	<u>10 PSF 5 PSF</u>	<u>36140</u>	→ 22

final Avg Q = 22 gpm

Packer-Test Record

Page 2 of 3

Project Name: Crescent Junction Characterisation Date: 11-23-05

Field Representative: M. Kautsky Borehole No. 212 Total Depth: 30 ft

Depth to Water (TOC): 120[±] Borehole Cleaned? Yes No Date: 11-23-05

Test Interval (BGL): from 20 to 30 ft. Swivel/Elbow Height (AGL) 5 ft.

Conductor Pipe, Type and Size: HX

Time	Gauge Pressure	Flow Meter Reading
<u>0845</u>	<u>10PSI</u>	<u>36170</u> > 25
<u>0846</u>	<u>10PSI</u>	<u>36195</u> > 26
<u>0847</u>	<u>10PSI</u>	<u>36221</u> > 28
<u>0848</u>	<u>10PSI</u>	<u>36249</u> > 28
<u>0849</u>	<u>10PSI</u>	<u>36277</u> > 28
<u>0850</u>	<u>10PSI</u>	<u>36305</u> > 27
<u>0851</u>	<u>10PSI</u>	<u>36332</u> > 28
<u>0852</u>	<u>10PSI</u>	<u>36360</u> > 28
<u>0853</u>	<u>10PSI</u>	<u>36388</u>
		<u>Final Avg Q = 28 gpm</u>

RECORD COPY

Stoller

established 1959

Packer-Test Record

Page 3 of 3

Project Name: Crescent Junction Characterization Date: 11-23-05

Field Representative: M. Kantsky Borehole No. 212 Total Depth: 30

Depth to Water (TOC): 120± Borehole Cleaned? Yes No Date: 11-23-05

Test Interval (BGL): from 20 to 30 ft. Swivel/Elbow Height (AGL) 5 ft.

Conductor Pipe, Type and Size: 1 1/2"

Time	Gauge Pressure	Flow Meter Reading
<u>09:00</u>	<u>SPSI</u>	<u>36409</u> > 20
<u>09:01</u>	<u>SPSI</u>	<u>36429</u> > 20
<u>09:02</u>	<u>SPSI</u>	<u>36449</u> > 21
<u>09:03</u>	<u>SPSI</u>	<u>36470</u> > 23
<u>09:04</u>	<u>5</u>	<u>36493</u> > 24
<u>09:05</u>	<u>5</u>	<u>36517</u> > 26
<u>09:06</u>	<u>5</u>	<u>36543</u> > 27
<u>09:07</u>	<u>5</u>	<u>36570</u> > 27
<u>09:08</u>	<u>5</u>	<u>36597</u>
		<u>Final Avg Q = 27</u>
		<u>(Re-test @ 5psi)</u>

Stoller

JOB NAME: Crescent Junction

PREPARED: M. Kautecky

REVIEWED:

SHEET NO: OF

PACKER TEST ANALYSES

BOREHOLE: 212

Depth: 20-30 ft

Pressure (h_2): 5 ps.

Unsaturated Zone Calculation:

Definitions: l = length of test section

$$T_u = u - D + H$$

u = Thickness of Unsaturated Material

D = distance from ground surface to bottom of test section

$$H = h_1 + h_2 - L$$

L = head loss; ignore if $Q < 4$ gpm

$$X = \frac{H}{T_u} (100); \text{ percent unsaturated material}$$

Reference Figure 17-6 U.S. Bureau of Rec. Earth Manual

$$l = 10 \text{ ft}$$

$$T_u = u - D + H = 120 \text{ ft} - 20 \text{ ft} + 43.8 \text{ ft} = 143.8 \text{ ft}$$

$$\frac{T_u}{l} = \frac{143.8 \text{ ft}}{10 \text{ ft}} = \boxed{14.4}$$

$$H = h_1 + h_2 - L = 43.8 \text{ ft}$$

$$X = \frac{H}{T_u} (100) = \frac{43.8 \text{ ft}}{143.8 \text{ ft}} (100) = \boxed{30}$$

WATER TESTING FOR PERMEABILITY

- Effective head, the difference in feet (m) between the elevation of the free water surface in the pipe and the elevation of the gauge plus the applied pressure. If a pressure transducer is used, the effective head in the test section is the difference in pressure before water is pumped into the test section and the pressure readings made during the test.

The following examples show some typical calculations using Methods 1 and 2 in the different zones shown in figure 17-5. Figure 17-6 shows the location of the zone 1 lower boundary for use in unsaturated materials.

Pressure permeability tests examples using Methods 1 and 2:

Borehole : 212
Depth : 20-30ft.
Pressure (h_w) : 5 psi

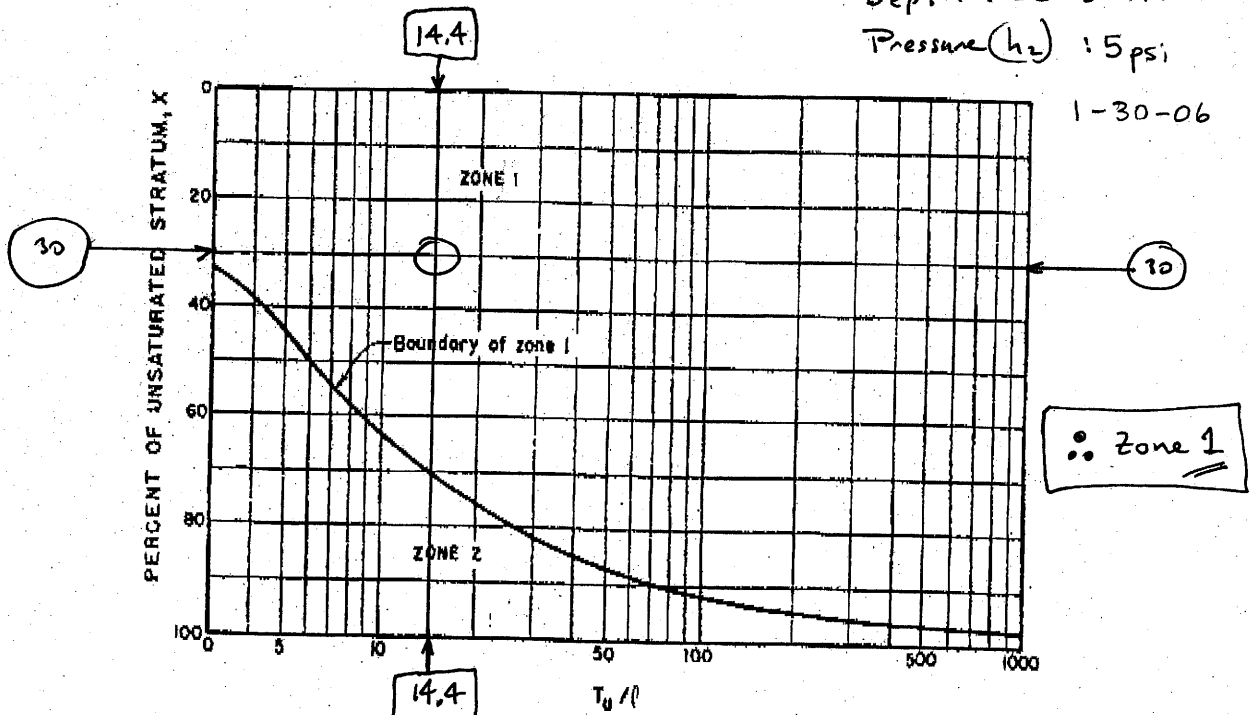

Figure 17-6.—Location of zone 1 lower boundary for use in unsaturated materials.

$$\frac{T_u}{l} = 14.4$$

$$X = 30$$

PRESSURE LOSS CURVE

1-30-06
Borehole 212
Depth 20-30 ft. (5 psi)

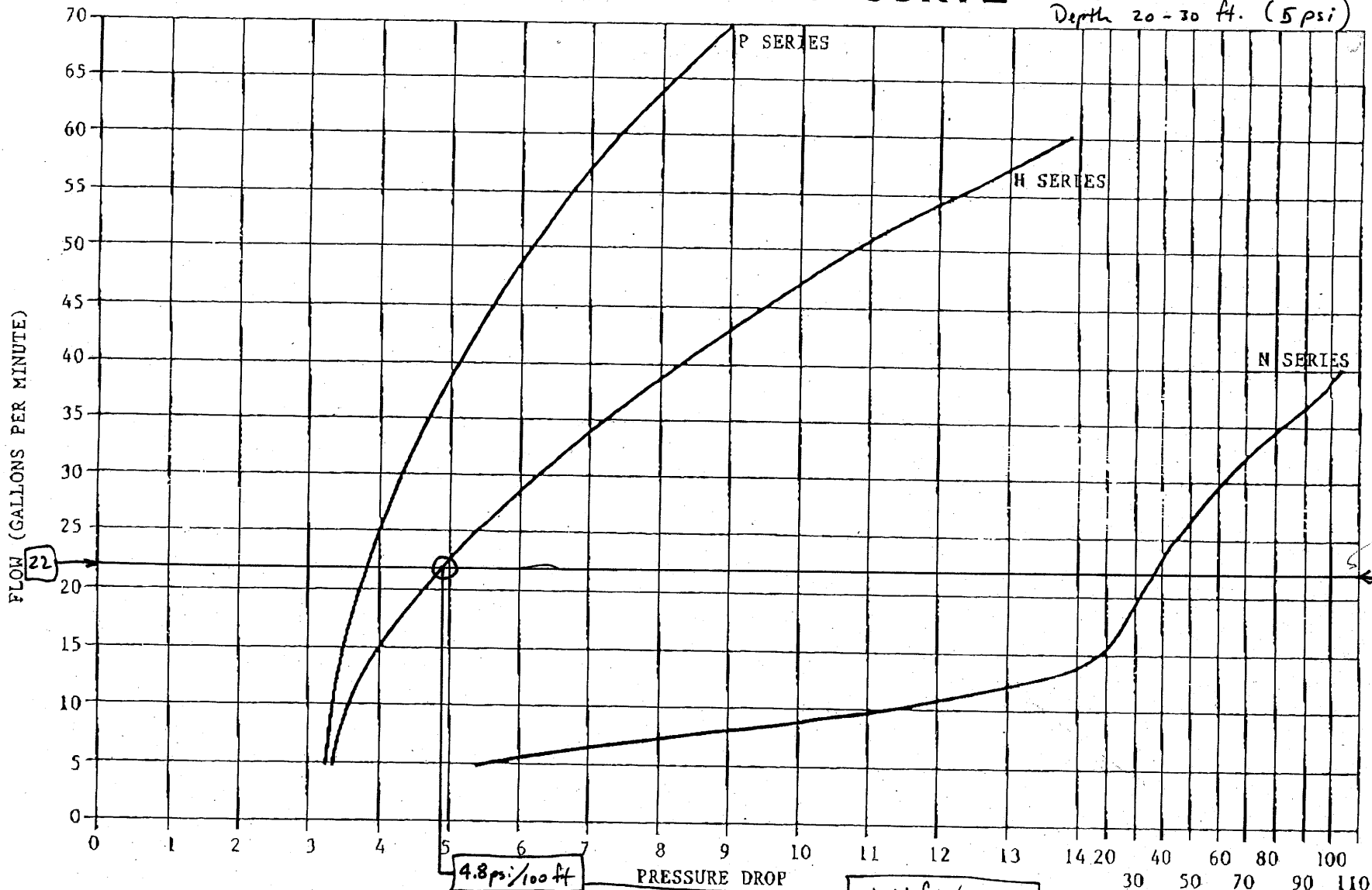

A-30

- * TEST PERFORMED IN WATER TEMPERATURE OF 60°F (15.5°C)
- * THIS CHART IS MEANT TO BE USED HAS A GUIDE ONLY. THE MEASUREMENTS WERE OBTAINED UNDER CONTROLLED LAB CONDITIONS AND ACTUAL FIELD CONDITIONS MAY VARY.

From: WIRELINE TYPE II service manual, Borehole Loggear.

WATER TESTING FOR PERMEABILITY

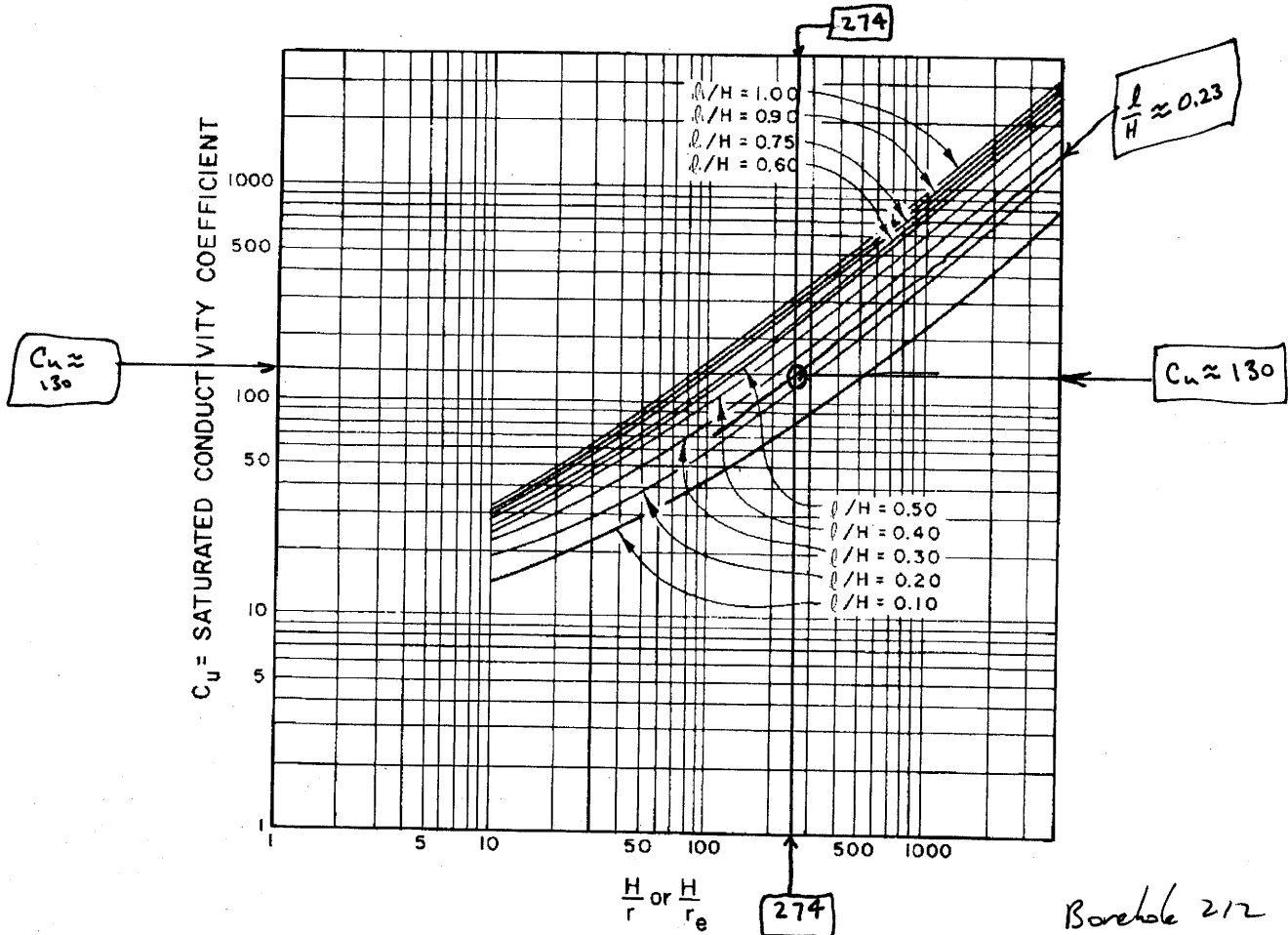

Figure 17-7.—Conductivity coefficients for permeability determination in unsaturated materials with partially penetrating cylindrical test wells.

Zone 2

Given: U , l , r , h_2 , Q , and L are as given in example 1, $D = 65$ feet, and $h_1 = 72$ feet

If the distance from the gauge to the bottom of the intake pipe is 62 feet, the total L is $(6.2)(0.76) = 4.7$ feet.

$$H = 72 + 57.8 - 4.7 = 125.1 \text{ feet}$$

Stoller

PACKER TEST SET-UP SHEET

Zone 1

JOB NO: _____ DATE: 1-30-06
 JOB NAME: Crescent Junction Site
 PREPARED: Mark Kautsky REVIEWED: _____
 SHEET NO: 1 OF 1 Borehole 212
 depth: 20-30 ft pressure: 5 psi

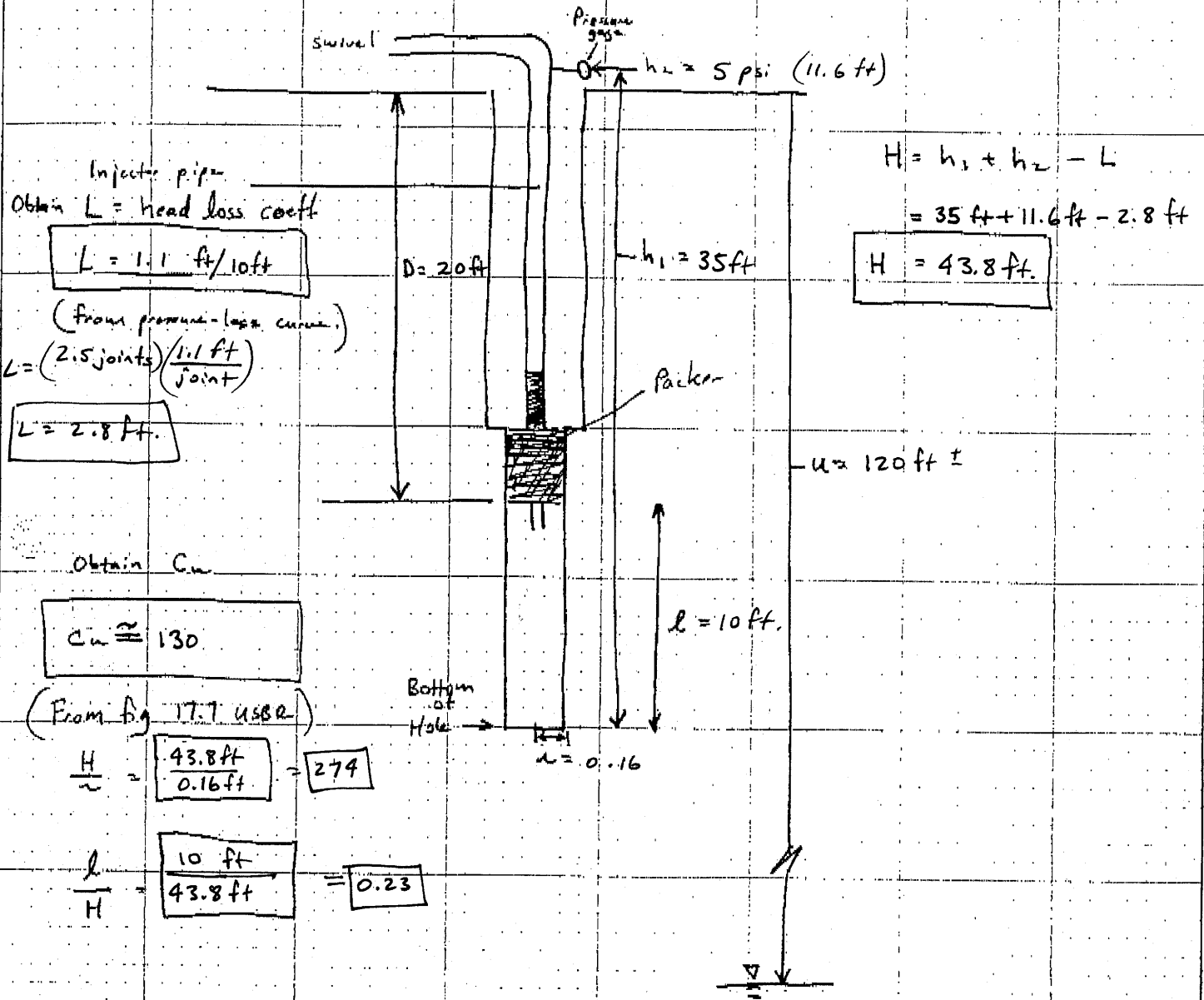

Injector pipe
 Obtain $L =$ head loss coeff

$$L = 1.1 \text{ ft/10ft}$$

(From pressure-loss curve.)

$$L = (2.5 \text{ joints}) / (1.1 \text{ ft/joint})$$

$$L = 2.8 \text{ ft.}$$

$$H = h_1 + h_2 - L$$

$$= 35 \text{ ft} + 11.6 \text{ ft} - 2.8 \text{ ft}$$

$$H = 43.8 \text{ ft.}$$

Obtain C_u

$$C_u \approx 130$$

(From fig. 17.7 USBR)

$$\frac{H}{l} = \frac{43.8 \text{ ft}}{0.16 \text{ ft}} = 274$$

$$\frac{l}{H} = \frac{10 \text{ ft}}{43.8 \text{ ft}} = 0.23$$

Calculate K :

Method 1,
 Zone 1,
 USBR

$$K = \frac{Q}{C_u \cdot l \cdot H} = \frac{(22 \text{ gal/min}) (1440 \text{ min/day}) (\frac{\text{ft}^3}{7.48 \text{ gal}})}{(130)(0.16 \text{ ft})(43.8 \text{ ft})}$$

$$K = 4.6 \text{ ft/day}$$

$$K = 1.6 \times 10^{-3} \text{ cm/s}$$

Stoller

CASE 1-23-06

JOB NAME Crescent Junction

PREPARED: M. Kautsky

REVIEWED:

SHEET NO: OF

PACKER TEST ANALYSES

BOREHOLE : 212

Depth : 20-30 ft.

Pressure (h_2) : 10 psi

Unsaturated Zone Calculation:

Definitions:

 l = length of test section $T_u = U + D + H$ U = Thickness of Unsaturated Material D = distance from ground surface to bottom of test section $H = h_1 + h_2 - L$ L = head loss ; ignore if $Q < 4 \text{ gpm}$ $X = \frac{H}{T_u} (100)$; percent unsaturated material

Reference Figure 17-6 U.S. Bureau of Rec. Earth Manual

$$l = 10 \text{ ft}$$

$$T_u = U + D + H = (120 + 20 + 54.7) \text{ ft} = 154.7 \text{ ft}$$

$$\frac{T_u}{l} = \frac{154.7 \text{ ft}}{10 \text{ ft}} = \boxed{15.5}$$

$$H = h_1 + h_2 - L = 54.7 \text{ ft} + 23.1 \text{ ft} - 3.4 \text{ ft} = 54.7 \text{ ft}$$

$$X = \frac{H}{T_u} (100) = \frac{54.7 \text{ ft}}{154.7 \text{ ft}} (100) = \boxed{35}$$

WATER TESTING FOR PERMEABILITY

- Effective head, the difference in feet (m) between the elevation of the free water surface in the pipe and the elevation of the gauge plus the applied pressure. If a pressure transducer is used, the effective head in the test section is the difference in pressure before water is pumped into the test section and the pressure readings made during the test.

The following examples show some typical calculations using Methods 1 and 2 in the different zones shown in figure 17-5. Figure 17-6 shows the location of the zone 1 lower boundary for use in unsaturated materials.

Pressure permeability tests examples using Methods 1 and 2:

Borehole : 212
 Depth : 20-30 ft
 Pressure (h_2) : 10 psi
 1-30-06

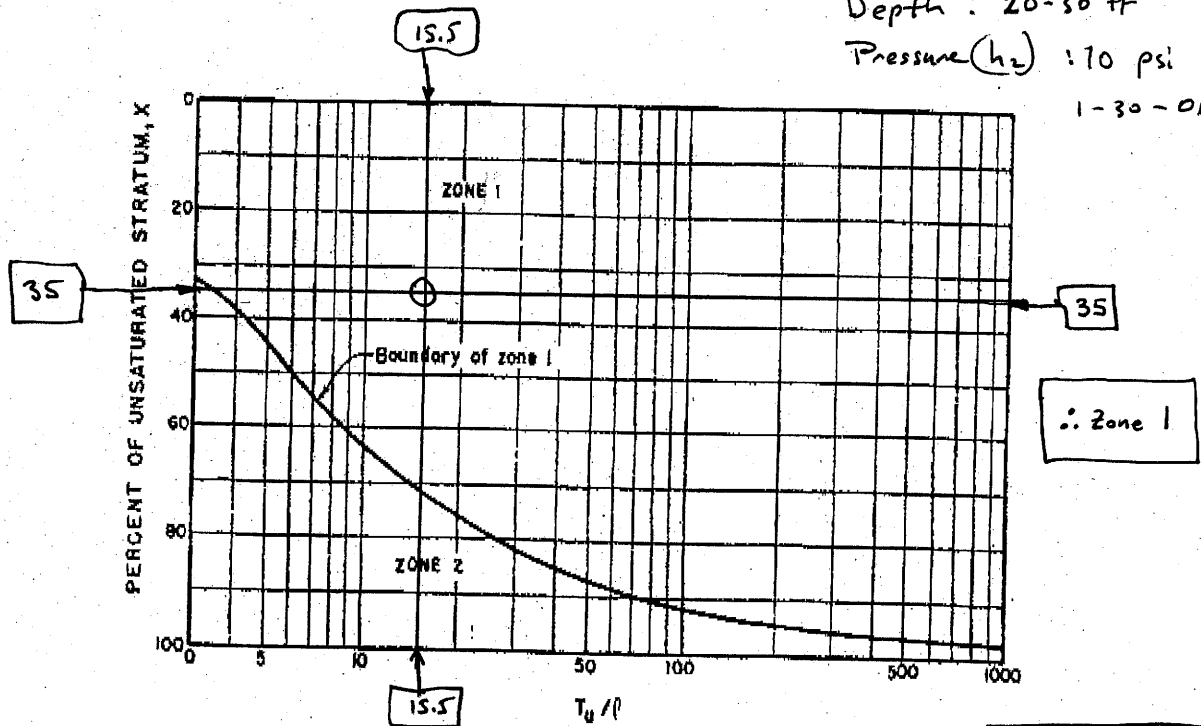

Figure 17-6.—Location of zone 1 lower boundary for use in unsaturated materials.

$$\frac{T_u}{l} = 15.5$$

$$X = 35$$

Borehole 212
 Depth 20-30 ft.
 Pressure: 10 psi (23.1 ft)

PRESSURE LOSS CURVE

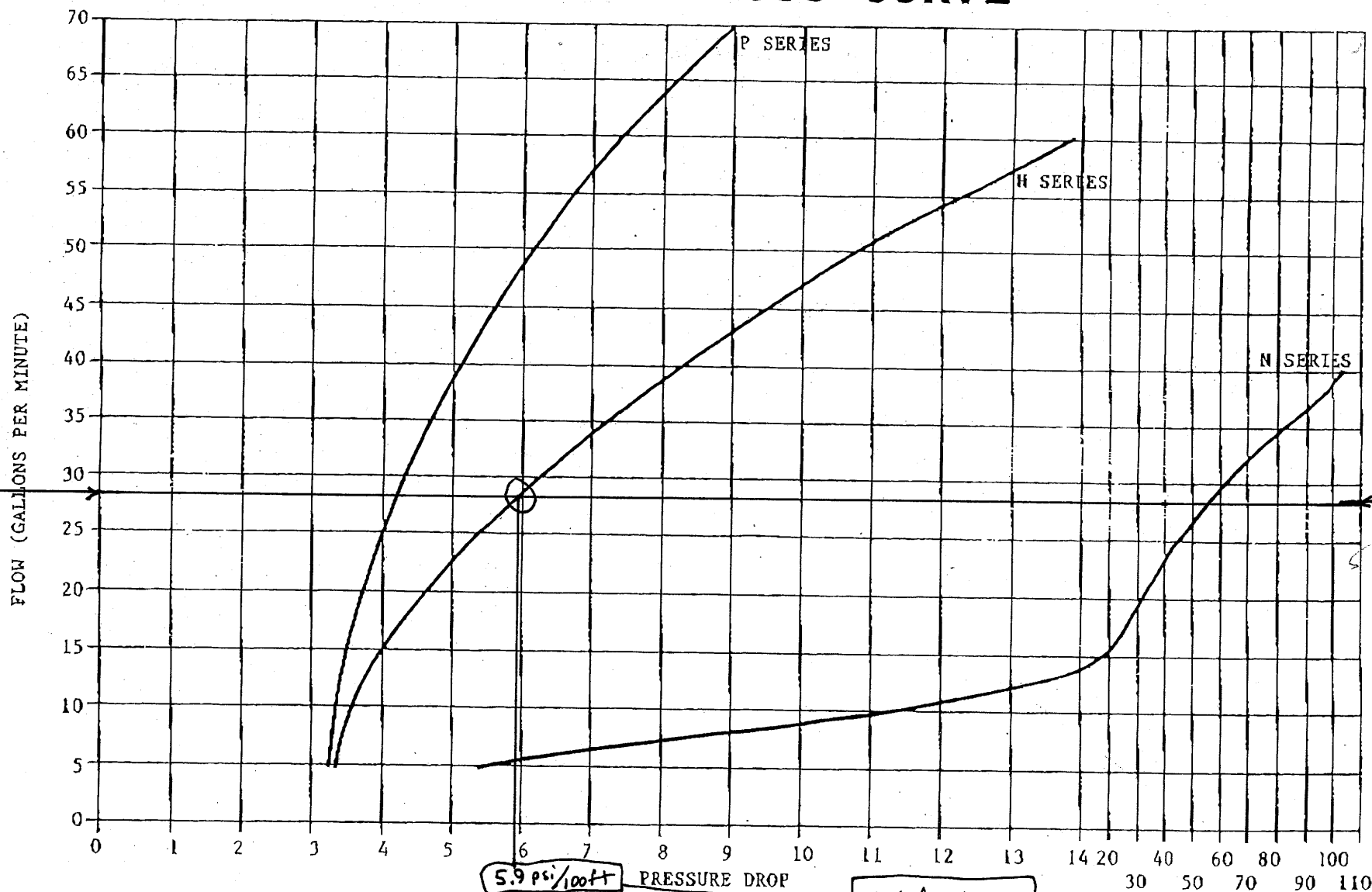

* TEST PERFORMED IN WATER TEMPERATURE OF 60°F (15.5°C)
 * THIS CHART IS MEANT TO BE USED HAS A GUIDE ONLY. THE MEASUREMENTS WERE OBTAINED UNDER CONTROLLED LAB CONDITIONS AND ACTUAL FIELD CONDITIONS MAY VARY.

From: WIRELINE TYPE II service manual, Bost Longyear.

A-35
 8018741018
 T-115 P. 29/32 F-001
 From-LAYNE CHRISTENSEN
 Jul-25-05 04:21pm

WATER TESTING FOR PERMEABILITY

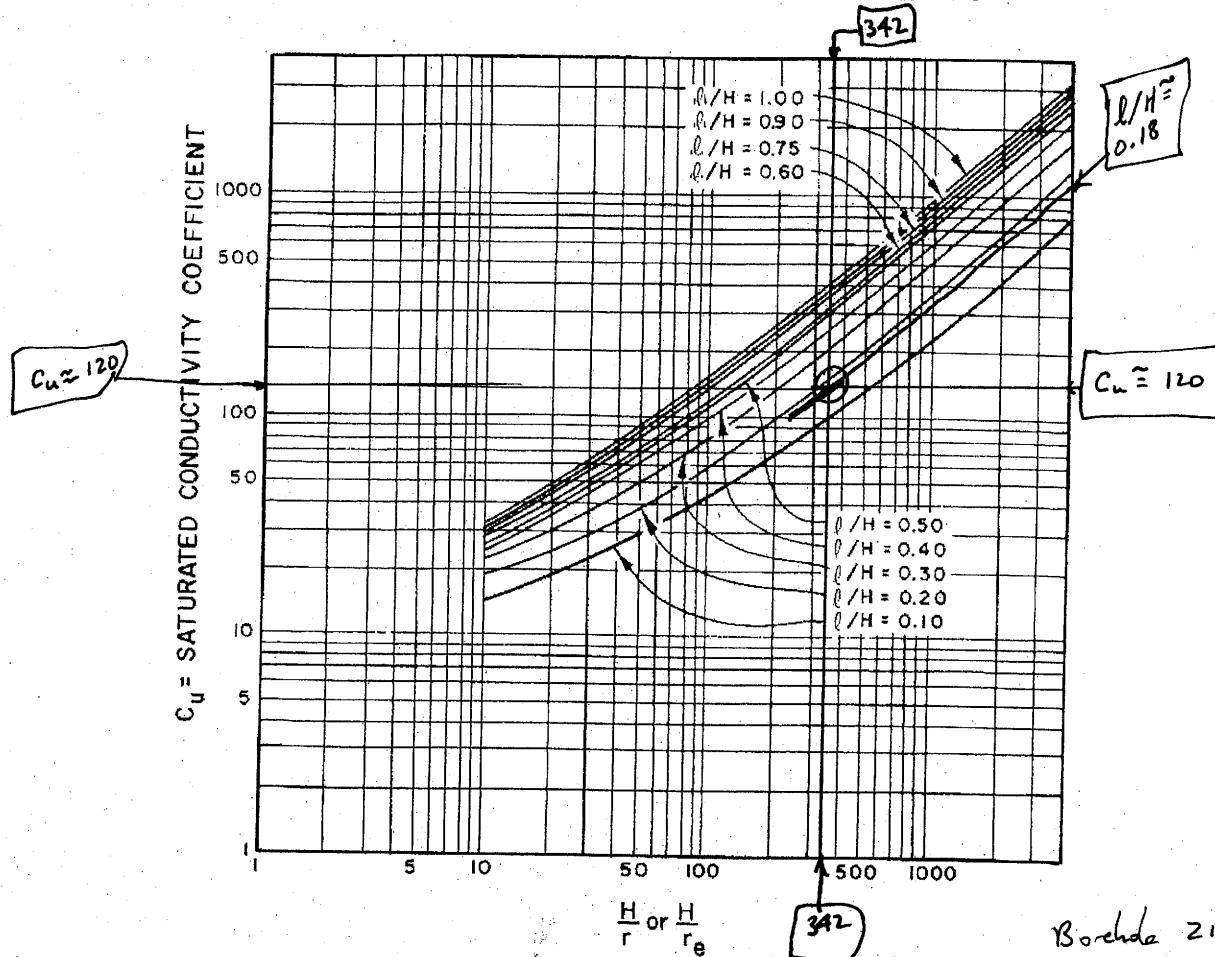

Figure 17-7.—Conductivity coefficients for permeability determination in unsaturated materials with partially penetrating cylindrical test wells.

Borchda 212
Depth 20-30 ft.
pressure 10 psi
1-30-06

Zone 2

Given: U , l , r , h_2 , Q , and L are as given in example 1, $D = 65$ feet, and $h_1 = 72$ feet

If the distance from the gauge to the bottom of the intake pipe is 62 feet, the total L is $(6.2)(0.76) = 4.7$ feet.

$$H = 72 + 57.8 - 4.7 = 125.1 \text{ feet}$$

Stoller

PACKER TEST SET-UP SHEET

JOB NO: _____ DATE: 1-30-06
 JOB NAME: Crescent Junction Site
 PREPARED: Mark Kautsky REVIEWED: _____
 SHEET NO: 1 OF _____
 Borehole: 212
 Depth: 20-30 ft.
 Pressure: 10 psi

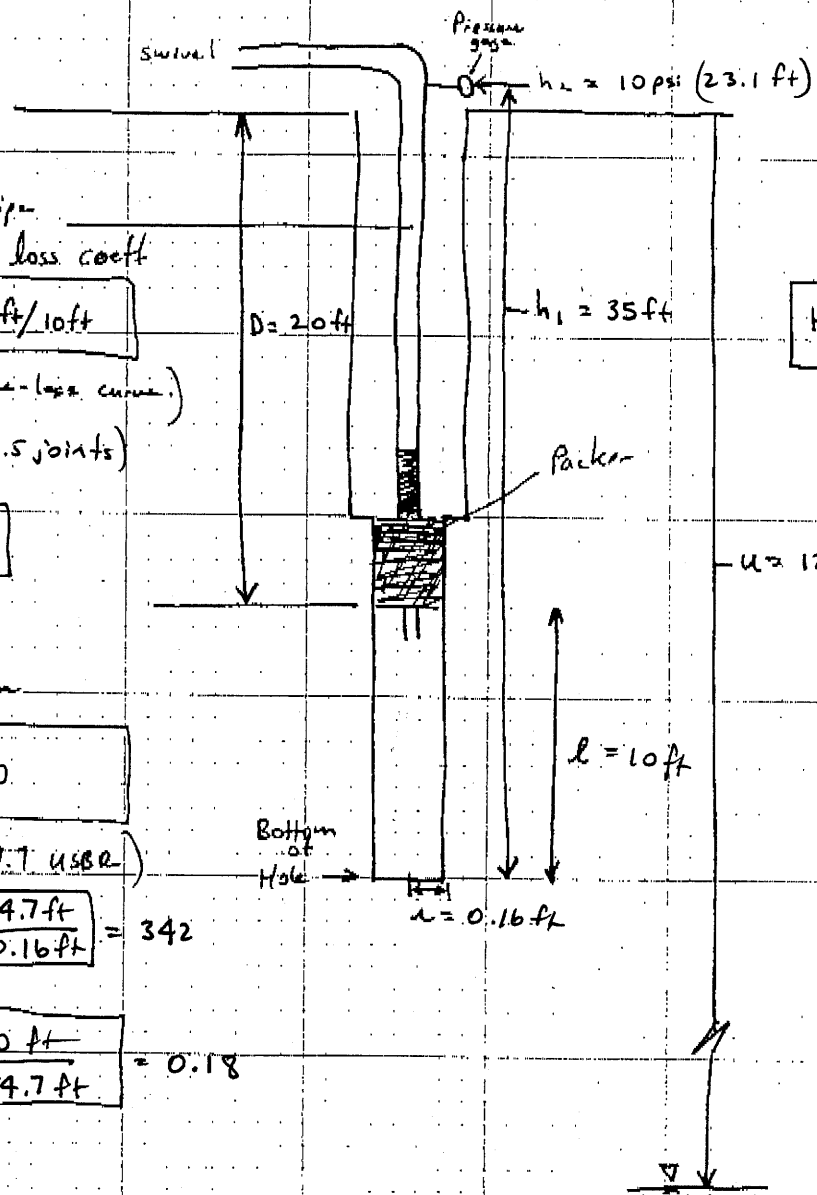

Injector pipe
 Obtain $L =$ head loss coeff
 $L = 1.4 \text{ ft}/10\text{ft}$
 (from pressure-loss curve)
 $L = \frac{1.4 \text{ ft}}{\text{joint}} (2.5 \text{ joints})$
 $L = 3.4 \text{ ft}$

$$H = h_1 + h_2 - L$$

$$= 35 \text{ ft} + 23.1 \text{ ft} - 3.4 \text{ ft}$$

$$H = 54.7 \text{ ft}$$

Obtain C_w
 $C_w \approx 120$

(From Fig 17.7 USBR)

$$\frac{H}{r} = \frac{54.7 \text{ ft}}{0.16 \text{ ft}} = 342$$

$$\frac{l}{H} = \frac{10 \text{ ft}}{54.7 \text{ ft}} = 0.18$$

Calculate K :
 Method 1,
 Zone 1,
 USBR

$$K = \frac{Q}{C_w r H} = \frac{\left(\frac{28 \text{ gal}}{\text{min}}\right) \left(\frac{1440 \text{ min}}{\text{day}}\right) \left(\frac{1 \text{ ft}^3}{7.48 \text{ gal}}\right)}{(120) (0.16 \text{ ft}) (54.7 \text{ ft})}$$

$$K = 5.1 \text{ ft/day}$$

$$K = 1.8 \times 10^{-3} \text{ cm/sec}$$

Stoller

PACKER TEST SET-UP SHEET

JOB NO: _____ DATE: 1-30-06
 JOB NAME: Crescent Junction site
 PREPARED: Mark Kautsky REVIEWED: _____
 Borehole 212
 SHEET NO.: 1 OF 1 Test Interval 20-30ft
 pressure: 5 psi (retest)

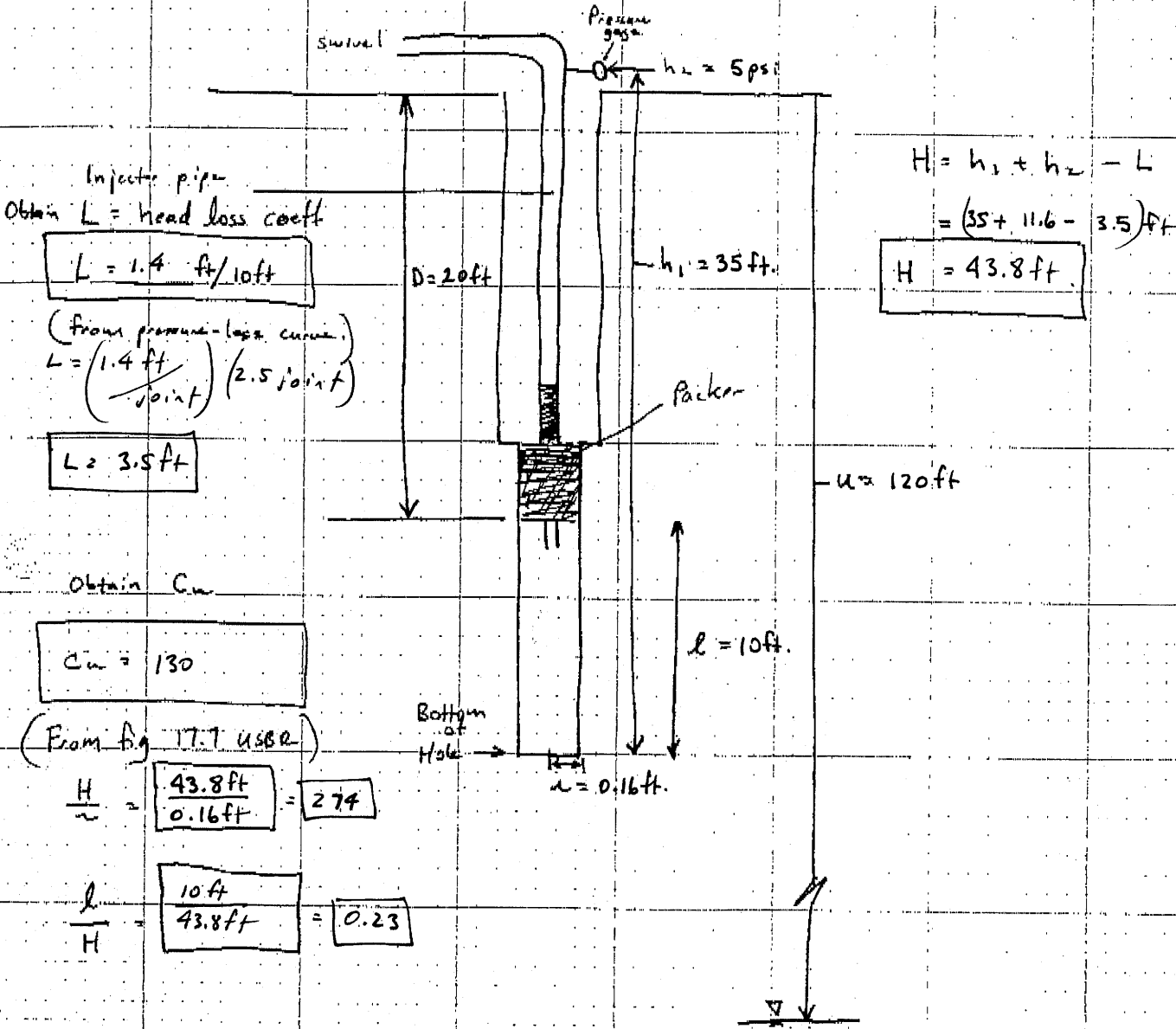

$$H = h_1 + h_2 - L$$

$$= (35 + 11.6 - 3.5) \text{ ft}$$

$$H = 43.8 \text{ ft}$$

Injector pipe
 Obtain $L = \text{head loss coeff}$
 $L = 1.4 \text{ ft/10ft}$
 (from pressure-loss curve)
 $L = (1.4 \text{ ft/joint}) (2.5 \text{ joint})$
 $L = 3.5 \text{ ft}$

Obtain C_w
 $C_w = 130$
 (From Fig. 17.7 USBR)
 $\frac{H}{\alpha} = \frac{43.8 \text{ ft}}{0.16 \text{ ft}} = 274$

$$\frac{l}{H} = \frac{10 \text{ ft}}{43.8 \text{ ft}} = 0.23$$

Calculate K :
 Method 1,
 Zone 1,
 USBR

$$K = \frac{Q}{C_w \alpha H} = \frac{(27 \text{ gal/min}) (1440 \text{ min/day}) (\frac{1 \text{ ft}^3}{7.48 \text{ gal}})}{(130) (0.16 \text{ ft}) (43.8 \text{ ft})}$$

$$K = 5.7 \text{ ft/d}$$

$$K = 2.0 \times 10^{-3} \text{ cm/sec}$$

Packer-Test Record

Page 1 of 2

Project Name: Crescent Junction Characterization Date: 11-30-05

Field Representative: M. Kantsky Borehole No.: 212 Total Depth: 40 ft

Depth to Water (TOC): 120 ± Borehole Cleaned? Yes No Date: 11-30-05

Test Interval (BGL): from 30 to 40 ft. Swivel/Elbow Height (AGL) 5 ft

Conductor Pipe, Type, and Size: H~~x~~ / ~~x~~ HQ

Reset pressure ↓

Time	Gauge Pressure	Flow Meter Reading	Flow
12:28	5 psi	36689	1
12:29	5 psi	36708	19 gpm
12:30	5 psi	36727	19 gpm
12:31	8 psi	36747	20 gpm
12:33	5 psi	36802	
12:34	5 psi	36840	38 gpm
12:35	5 psi	36878	38 gpm
12:36	5 psi	36913	35 gpm
12:37	5 psi	36947	34 gpm
12:38	5 psi	36977	30 gpm
12:39	5 psi	37004	27 gpm
12:40	5 psi 4	37023	19 gpm
12:41	5 psi 3	37035	12 gpm
12:42	5 psi ↓ 0	37043	8 gpm
	Ran out of water.		

Packer-Test Record

Page 2 of 2

Project Name: Crescent Junction Characterization Date: 11-30-05
 Field Representative: Mark Kautsky Borehole No.: 212 Total Depth: 40 ft.
 Depth to Water (TOC): 120± Borehole Cleaned? Yes No Date: 11-30-05
 Test Interval (BGL): from 30 to 40 ft. Swivel/Elbow Height (AGL) 5 ft.
 Conductor Pipe, Type, and Size: Hx/Ha

Time	Gauge Pressure	Flow Meter Reading
14:30	5 psi	37102
14:31	5 psi	37135 33 gal/min
14:32	5 psi	37171 36 gpm
14:33	5 psi	37208 37 gpm
14:34	5 psi	37244 36 gpm
14:35	5 psi	37282 38 gpm
14:36	5 psi	37320 38 gpm
14:37	5 psi	37358 38 gpm
<hr/>		
14:38	10 psi	37400
14:39	10 psi	37442 42 gpm
14:40	10 psi	37485 43 gpm
14:41	10 psi	37528 43 gpm
14:42	10 psi	37571 43 gpm
<hr/>		
14:43	5 psi	37610
14:44	5 psi	37648 38 gpm
14:45	5 psi	37686 38 gpm
14:46	5 psi	37637722 36 gpm
14:47	5 psi	37760 38 gpm

Stoller

DATE 1-23-06

JOB NAME Crescent Junction

PREPARED: M. Kautsky

REVIEWED:

SHEET NO. _____ OF _____

PACKER TEST ANALYSES

Unsaturated Zone Calculation:

BOREHOLE: 212

Depth: 30-40 ft.

Pressure (h_2): 5 psi (11.6 ft)

Definitions:

 L = length of test section $T_u = u - D + H$ u = Thickness of Unsaturated Material D = distance from ground surface to bottom of test section $H = h_1 + h_2 - L$ L = head loss; ignore if $Q < 4$ gpm $X = \frac{H}{T_u} (100)$; percent unsaturated material

Reference Figure 17-6 U.S. Bureau of Rec. Earth Manual

$$L = 10 \text{ ft}$$

$$T_u = u - D + H = 120 - 30 + 50.3 = 140.3$$

$$\frac{T_u}{L} = \frac{140.3 \text{ ft}}{10 \text{ ft}} = \boxed{14}$$

$$H = h_1 + h_2 - L = 50.3 \text{ ft}$$

$$X = \frac{H}{T_u} (100) = \frac{50.3 \text{ ft}}{140.3 \text{ ft}} (100) = \boxed{36}$$

WATER TESTING FOR PERMEABILITY

- Effective head, the difference in feet (m) between the elevation of the free water surface in the pipe and the elevation of the gauge plus the applied pressure. If a pressure transducer is used, the effective head in the test section is the difference in pressure before water is pumped into the test section and the pressure readings made during the test.

The following examples show some typical calculations using Methods 1 and 2 in the different zones shown in figure 17-5. Figure 17-6 shows the location of the zone 1 lower boundary for use in unsaturated materials.

Pressure permeability tests examples using Methods 1 and 2:

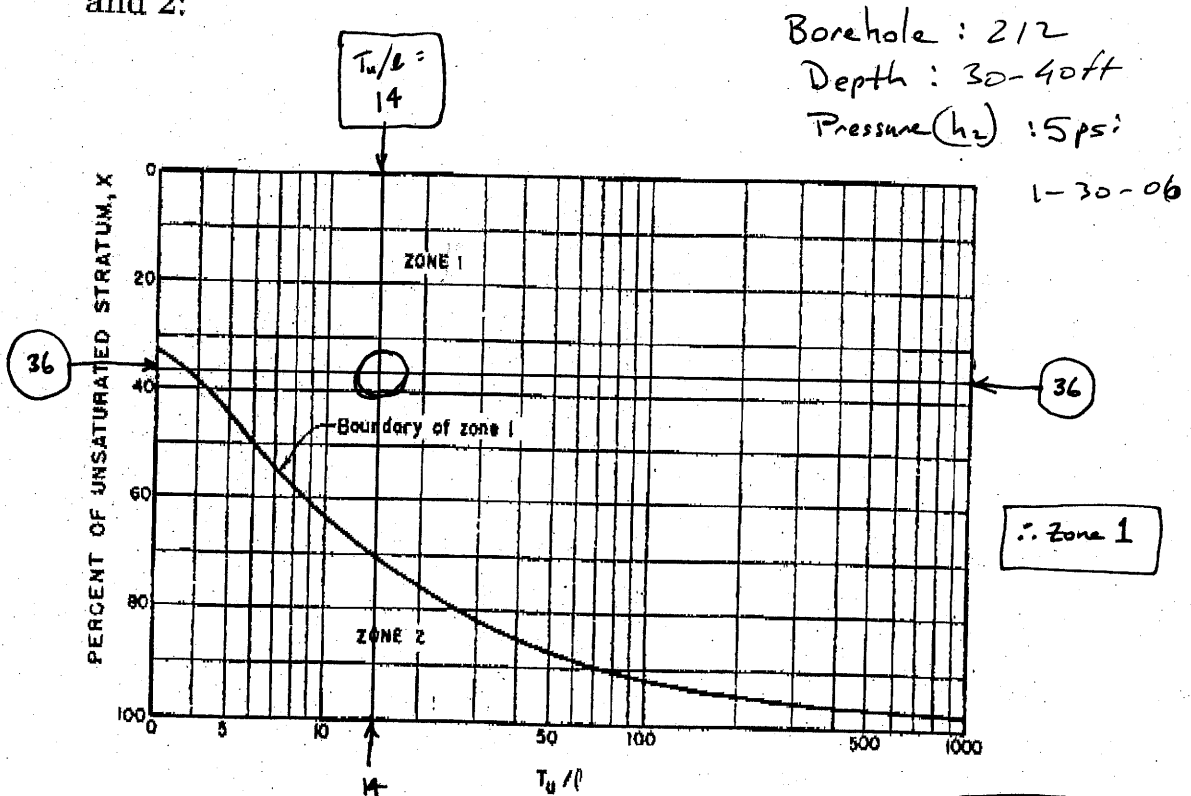

Figure 17-6.—Location of zone 1 lower boundary for use in unsaturated materials.

$$\frac{T_u}{e} = 14$$

$$X = 36$$

PRESSURE LOSS CURVE

1-30-06
 Borehole 212
 Interval 30-40 ft.
 Pressure 5 psi (4.6 ft)

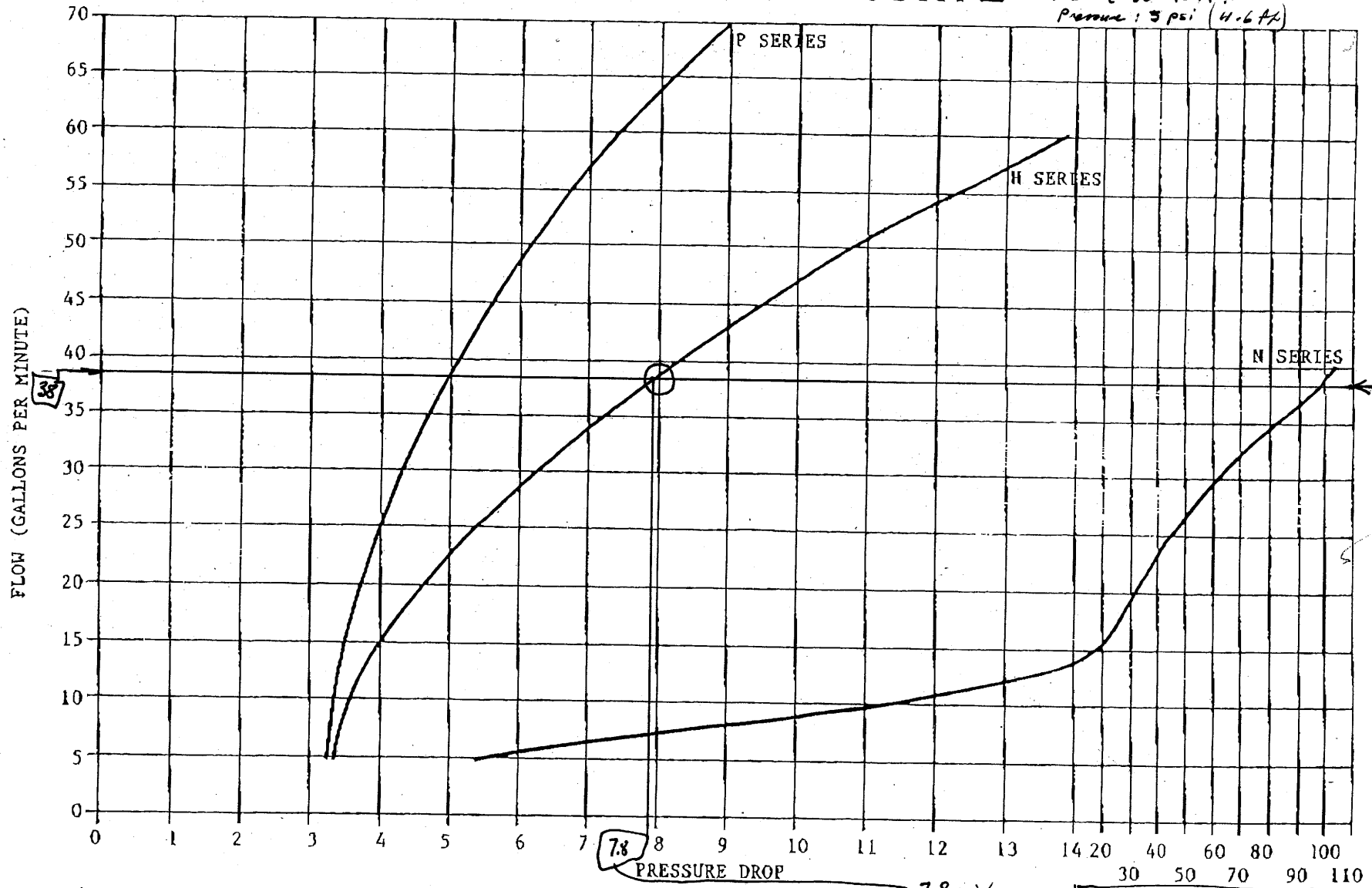

* TEST PERFORMED IN WATER TEMPERATURE OF 60°F (15.5°C)

* THIS CHART IS MEANT TO BE USED HAS A GUIDE ONLY. THE MEASUREMENTS WERE OBTAINED UNDER CONTROLLED LAB CONDITIONS AND ACTUAL FIELD CONDITIONS MAY VARY.

$7.8 \text{ psi}/100 \text{ ft} = 1.8 \text{ ft}/10\text{-ft joint}$

From: WIRELINE TYPE II service manual, Boat Longyear.

Jul-25-05 04:12 PM From-LAYNE CHRISTENSEN 8010741018 T-115 P.28/32 F-001 A-43

WATER TESTING FOR PERMEABILITY

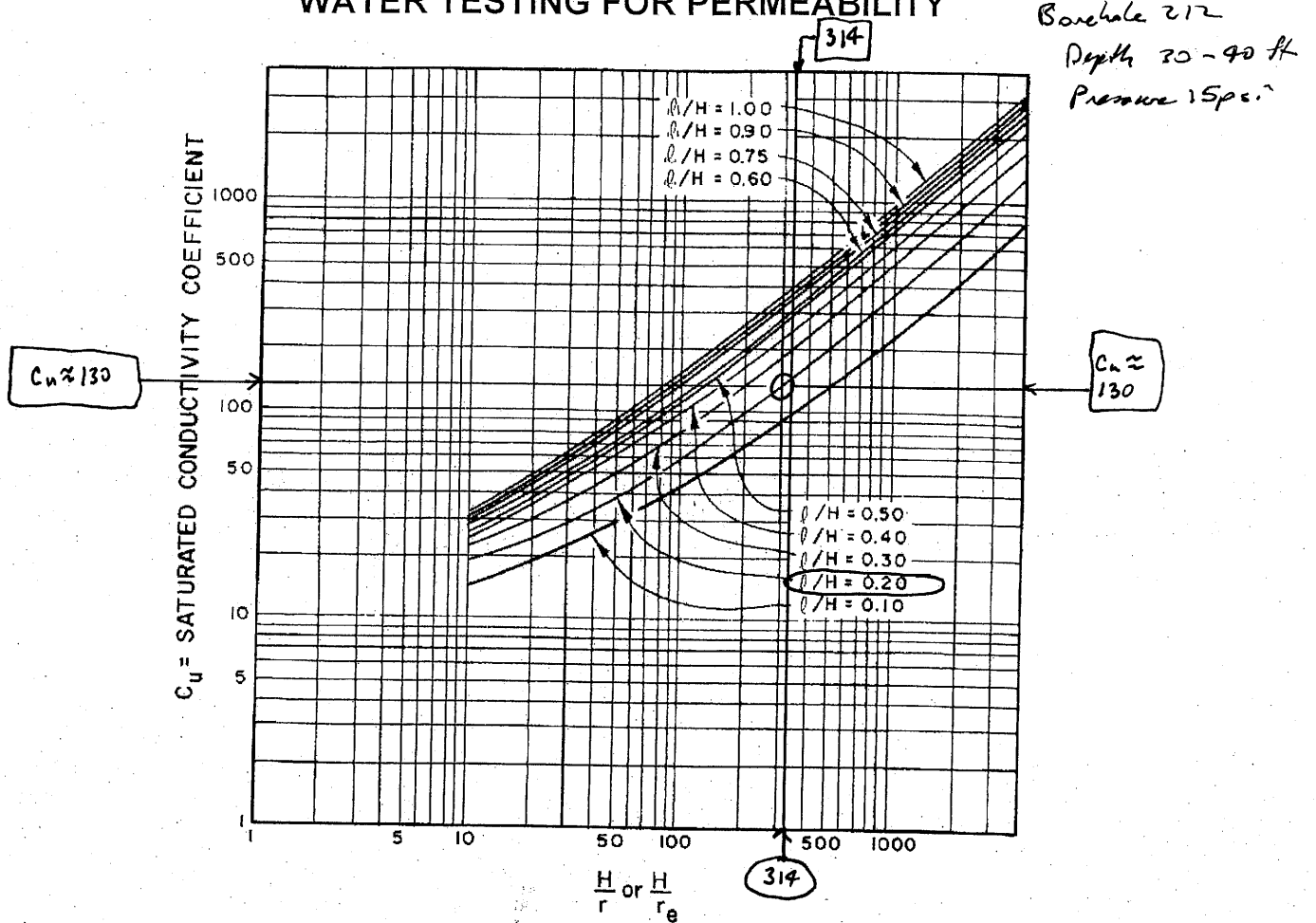

Figure 17-7.—Conductivity coefficients for permeability determination in unsaturated materials with partially penetrating cylindrical test wells.

Zone 2

Given: U , ℓ , r , h_2 , Q , and L are as given in example 1, $D = 65$ feet, and $h_1 = 72$ feet

If the distance from the gauge to the bottom of the intake pipe is 62 feet, the total L is $(6.2)(0.76) = 4.7$ feet.

$$H = 72 + 57.8 - 4.7 = 125.1 \text{ feet}$$

Stoller

PACKER TEST SET-UP SHEET

JOB NO: _____ DATE: 1-30-06

JOB NAME: Crescent Junction Site

PREPARED: Mark Kautsky REVIEWED: _____

SHEET NO: 1 OF _____
 Borehole 212
 Depth 30-40 ft.
 pressure: 5psi (11.6 ft)

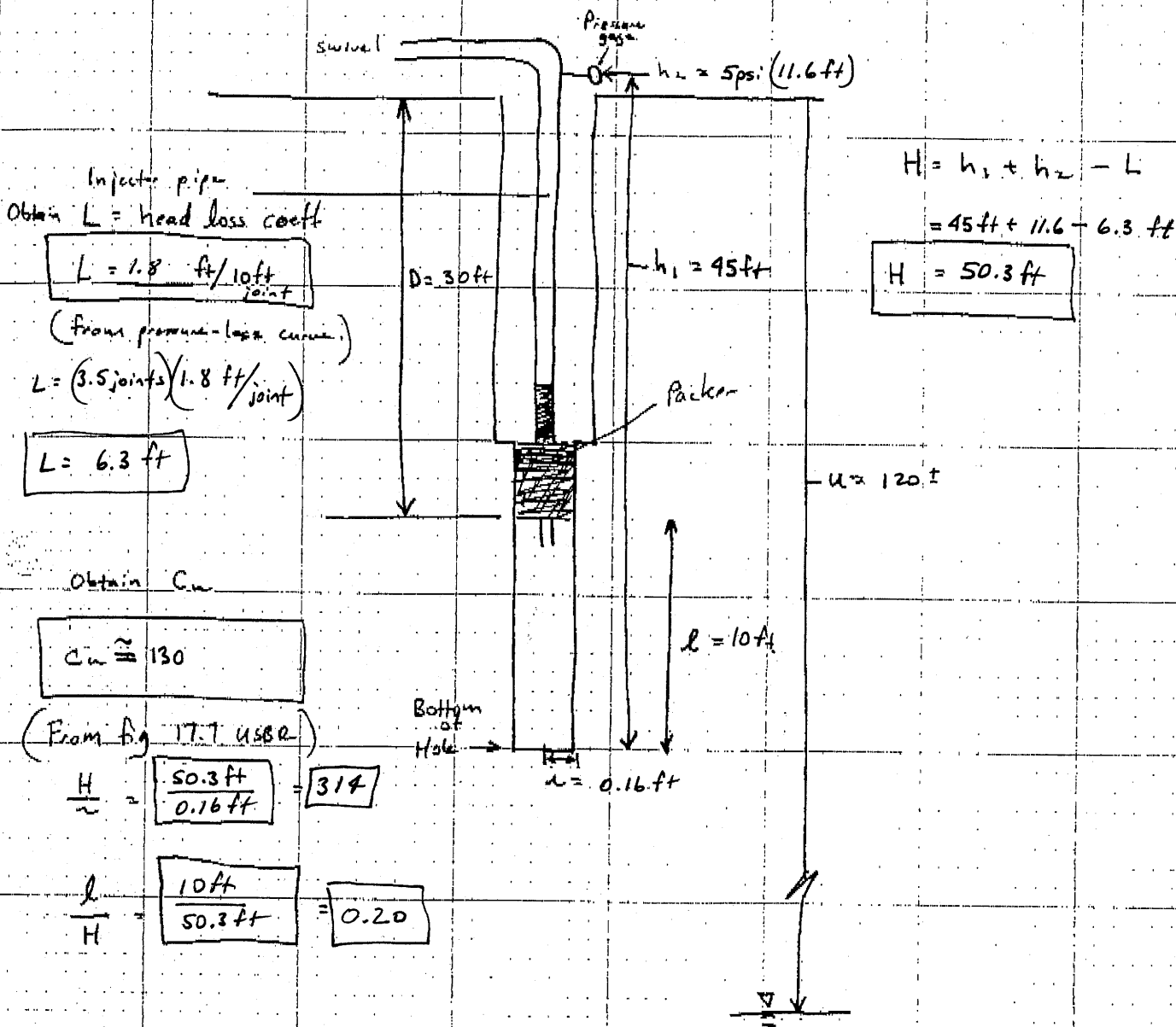

Injector pipe
 Obtain $L =$ head loss coeff
 $L = 1.8 \text{ ft/10ft joint}$
 (From pressure-loss curve)
 $L = (3.5 \text{ joints})(1.8 \text{ ft/joint})$

$$L = 6.3 \text{ ft}$$

Obtain C_w

$$C_w \approx 130$$

(From Fig. 17.7 USBR)

$$\frac{H}{u} = \frac{50.3 \text{ ft}}{120 \text{ ft}} = 0.419$$

$$\frac{l}{H} = \frac{10 \text{ ft}}{50.3 \text{ ft}} = 0.20$$

Calculate K :

Method 1,
 Zone 1,
 USBR

$$K = \frac{Q}{C_w u H} = \frac{\left(\frac{38 \text{ gal}}{\text{min}}\right) \left(\frac{1440 \text{ min}}{\text{d}}\right) \left(\frac{\text{ft}^3}{7.48 \text{ gal}}\right)}{(130) (0.16 \text{ ft}) (50.3 \text{ ft})}$$

$$K = 7 \text{ ft/day}$$

$$K = 2.5 \times 10^{-3} \text{ cm/d}$$

Stoller

DATE 1-23-06

JOB NAME Crescent Junction

PREPARED: M. Kautsky

REVIEWED:

SHEET NO. OF

PACKER TEST ANALYSES

BOREHOLE : 212

Depth : 30 - 40 ft.

Pressure (h_2) : 10 psi (23.1 ft)

Unsaturated Zone Calculation:

Definitions:

 l = length of test section

$$T_u = u - D + H$$

 u = Thickness of Unsaturated Material D = distance from ground surface to bottom of test section

$$H = h_1 + h_2 - L$$

 L = head loss ; ignore if $Q < 4$ gpm

$$X = \frac{H}{T_u} (100) ; \text{percent unsaturated material}$$

Reference Figure 17-6 U.S. Bureau of Rec. Earth Manual

$$l = 10 \text{ ft.}$$

$$T_u = u - D + H = 120 \text{ ft} - 30 \text{ ft} + 60.7 \text{ ft} = 150.7 \text{ ft}$$

$$\frac{T_u}{l} = \frac{150.7 \text{ ft}}{10 \text{ ft}} = \boxed{15.1}$$

$$H = h_1 + h_2 - L = 60.7 \text{ ft}$$

$$X = \frac{H}{T_u} (100) = \frac{60.7 \text{ ft}}{150.7 \text{ ft}} (100) = \boxed{40}$$

WATER TESTING FOR PERMEABILITY

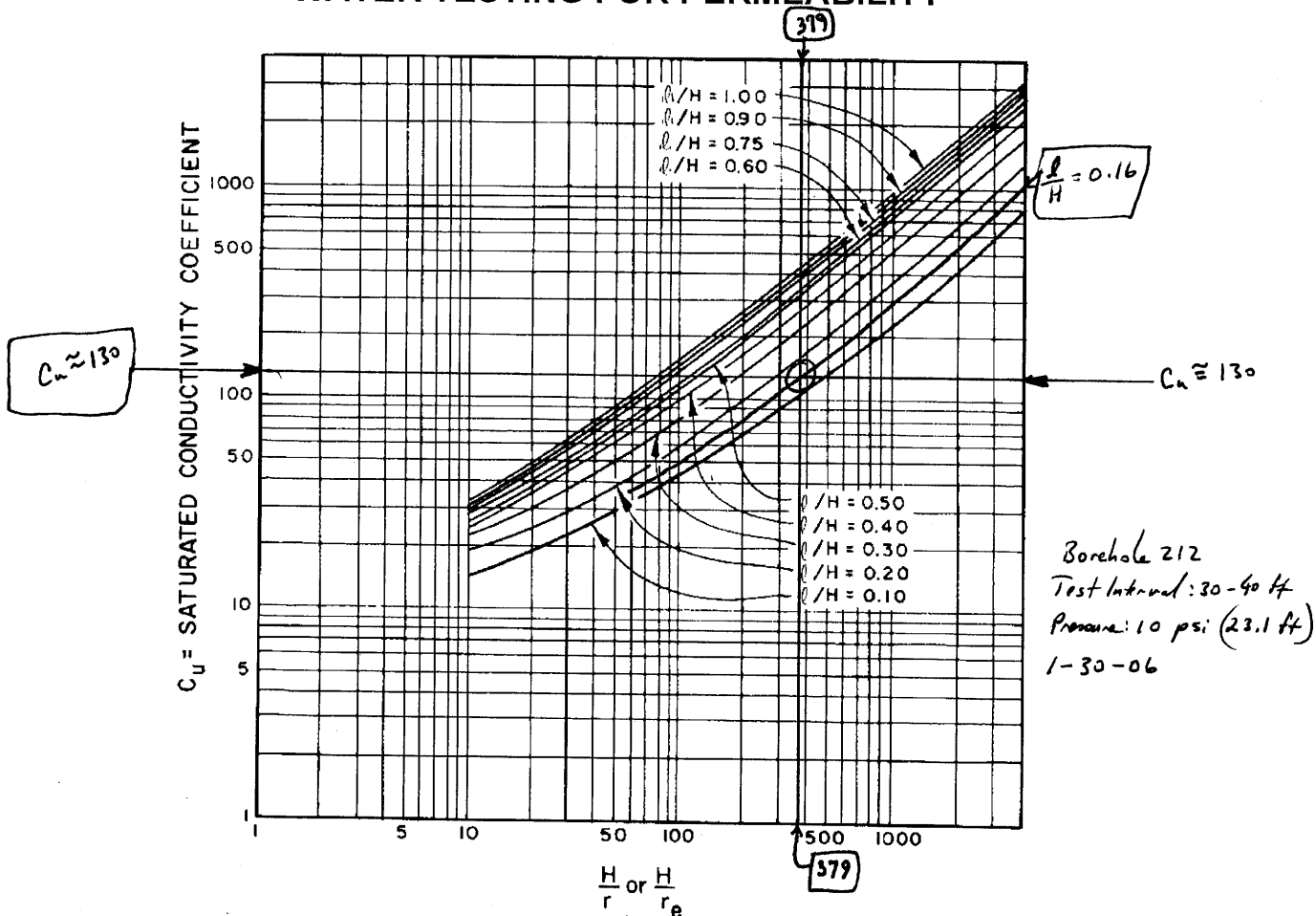

Figure 17-7.—Conductivity coefficients for permeability determination in unsaturated materials with partially penetrating cylindrical test wells.

Zone 2

Given: U , l , r , h_2 , Q , and L are as given in example 1, $D = 65$ feet, and $h_1 = 72$ feet

If the distance from the gauge to the bottom of the intake pipe is 62 feet, the total L is $(6.2)(0.76) = 4.7$ feet.

$$H = 72 + 57.8 - 4.7 = 125.1 \text{ feet}$$

PRESSURE LOSS CURVE

1-30-06
 Borehole 212
 Test Interval 30-40 ft.
 Pressure 10 psi (23.1 ft)

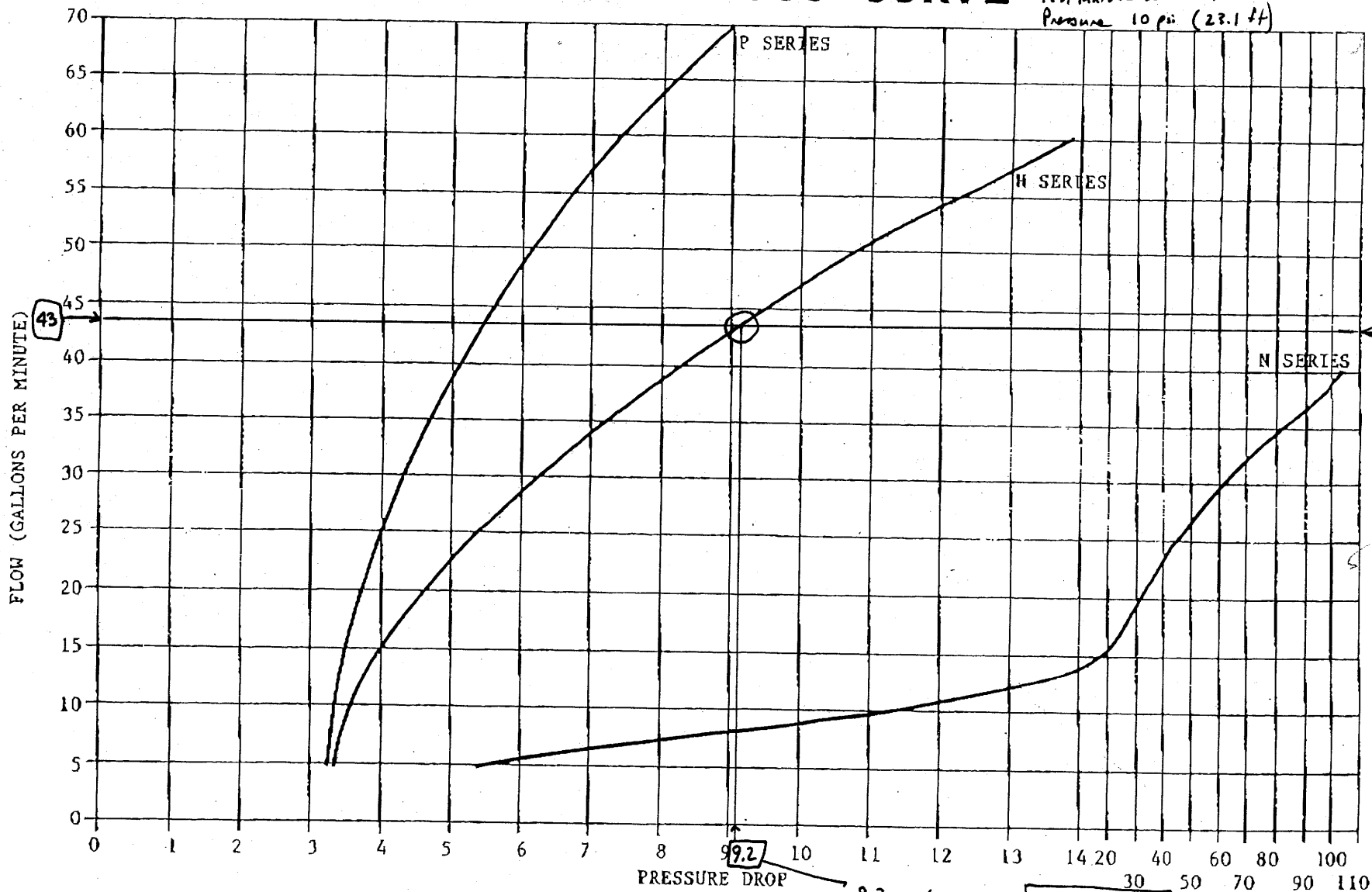

- * TEST PERFORMED IN WATER TEMPERATURE OF 60°F (15.5°C)
- * THIS CHART IS MEANT TO BE USED HAS A GUIDE ONLY. THE MEASUREMENTS WERE OBTAINED UNDER CONTROLLED LAB CONDITIONS AND ACTUAL FIELD CONDITIONS MAY VARY.

From: WIRELINE TYPE II service manual, Boat Longyear.

Jul-25-05 04:21pm From=LAYNE CHRISTENSEN 8018741018 A-48 T-115 P.28/32 F-001

WATER TESTING FOR PERMEABILITY

- Effective head, the difference in feet (m) between the elevation of the free water surface in the pipe and the elevation of the gauge plus the applied pressure. If a pressure transducer is used, the effective head in the test section is the difference in pressure before water is pumped into the test section and the pressure readings made during the test.

The following examples show some typical calculations using Methods 1 and 2 in the different zones shown in figure 17-5. Figure 17-6 shows the location of the zone 1 lower boundary for use in unsaturated materials.

Pressure permeability tests examples using Methods 1 and 2:

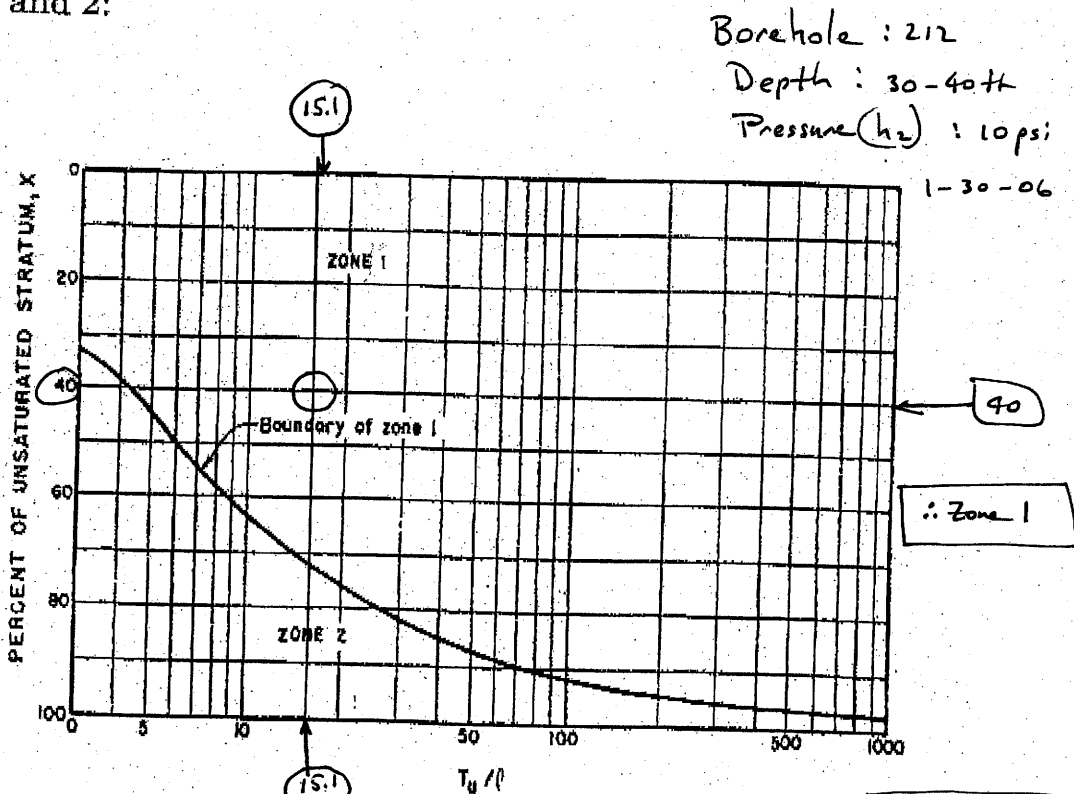

Figure 17-6.—Location of zone 1 lower boundary for use in unsaturated materials.

$$\frac{T_u}{e} = 15.1$$

$$X = 40$$

JOB NO: _____ DATE: 1-30-06
 JOB NAME: Crescent Junction Site
 PREPARED: Mark Kautsky REVIEWED: _____
 SHEET NO: 1 OF _____
 Borehole 212
 Test Interval 30-40 ft.
 Pressure: 10 psi (23.1 ft)

Stoller

PACKER TEST SET-UP SHEET

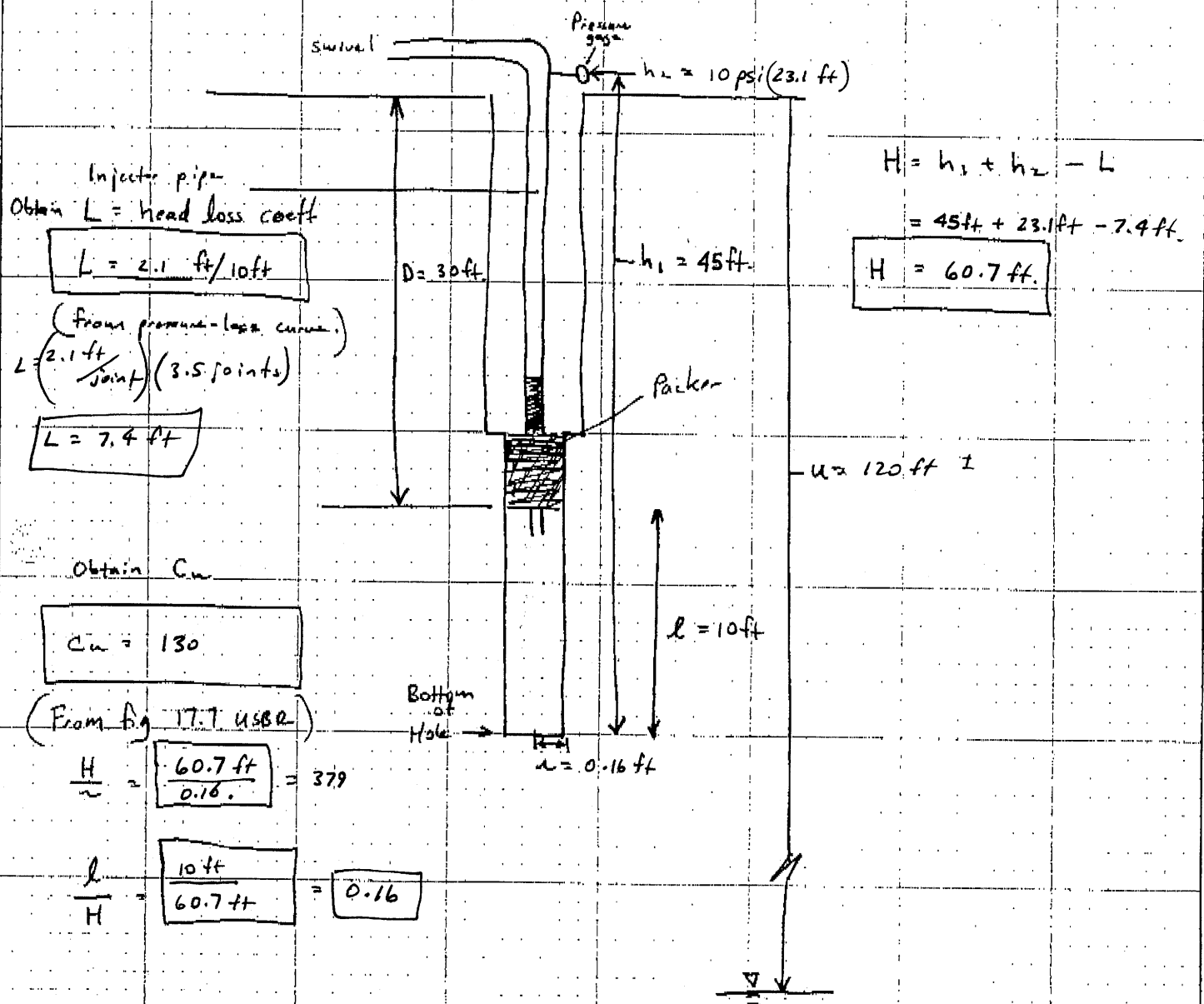

Injector pipe
 Obtain $L =$ head loss coeff
 $L = 2.1 \text{ ft}/10\text{ft}$
 (From pressure-loss curve)
 $L = (2.1 \text{ ft/joint}) (3.5 \text{ joints})$
 $L = 7.4 \text{ ft}$

$$H = h_1 + h_2 - L$$

$$= 45\text{ft} + 23.1\text{ft} - 7.4\text{ft}$$

$$H = 60.7 \text{ ft.}$$

Obtain C_u
 $C_u = 130$
 (From Fig. 17.7 USBR)
 $\frac{H}{u} = \frac{60.7 \text{ ft}}{0.16} = 379$
 $\frac{l}{H} = \frac{10 \text{ ft}}{60.7 \text{ ft}} = 0.16$

Calculate K :
 Method 1,
 Zone 1,
 USBR
 $K = \frac{Q}{C_u \cdot H} ; K = \frac{(43 \text{ gal/min}) (1490 \text{ m}^3/d)}{(130) (0.16 \text{ ft}) (60.7 \text{ ft})}$
 $K = 6.5 \text{ ft/d}$
 $K = 2.3 \times 10^{-3} \text{ cm/s}$

Stoller

PACKER TEST SET-UP SHEET

JOB NO: _____ DATE: 1-30-06
 JOB NAME: Crescent Junction Site
 PREPARED: Mark Kautsky REVIEWED: _____
 SHEET NO: 1 OF 1
 Borehole 212
 Depth 30-40 ft
 pressure: 5 psi (retest)

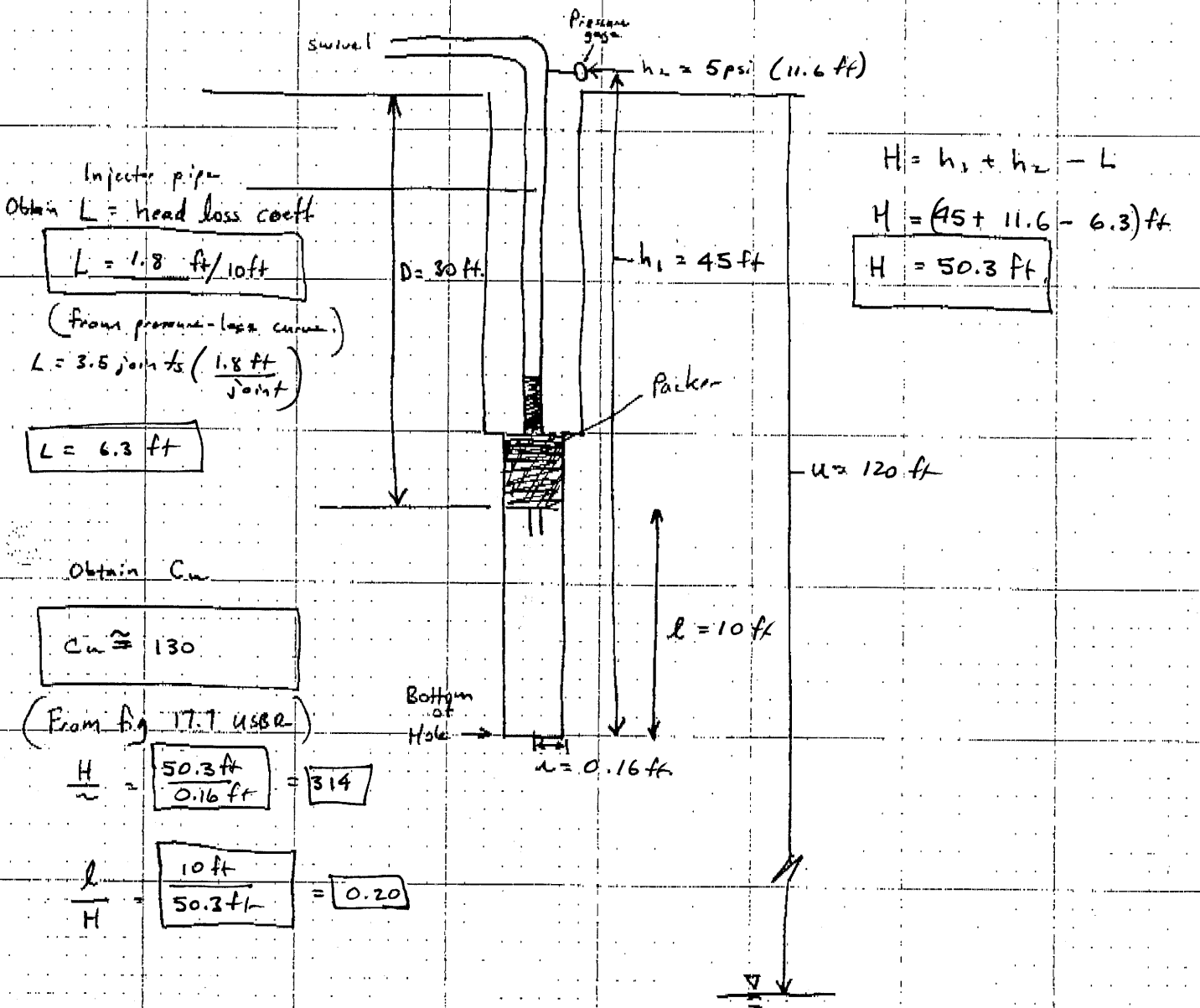

Injector pipe
 Obtain L = head loss coeff

$$L = 1.8 \text{ ft}/10 \text{ ft}$$

(From pressure-loss curve)

$$L = 3.5 \text{ joints} \left(\frac{1.8 \text{ ft}}{\text{joint}} \right)$$

$$L = 6.3 \text{ ft}$$

Obtain C_u

$$C_u \approx 130$$

(From Fig. 17.7 USBR)

$$\frac{H}{h} = \frac{50.3 \text{ ft}}{0.16 \text{ ft}} = 314$$

$$\frac{l}{H} = \frac{10 \text{ ft}}{50.3 \text{ ft}} = 0.20$$

Calculate K :

Method 1,
 Zone 1,
 USBR

$$K = \frac{Q}{C_u \cdot h} = \frac{\left(\frac{38 \text{ gal}}{\text{min}} \right) \left(\frac{1440 \text{ min}}{d} \right) \left(\frac{1 \text{ ft}^3}{7.48 \text{ gal}} \right)}{(130) (0.16 \text{ ft}) (50.3 \text{ ft})}$$

$$K = 7.0 \text{ ft/day}$$

$$K = 2.5 \times 10^{-3} \text{ cm/s}$$

Packer-Test Record

Page 1 of 2

Project Name: Crescent Junction Characterization Date: 12-1-05

Field Representative: Mark Kautsky Borehole No.: 213 Total Depth: 30 ft

Depth to Water (TOC): 120 ± ft. Borehole Cleaned? Yes No Date: 12-1-05

Test Interval (BGL): from 20 to 30 ft. ft. Swivel/Elbow Height (AGL) 6 ft.

Conductor Pipe, Type, and Size: HQ/HX

Time	Gauge Pressure	Flow Meter Reading
13:01	5 psi	37784.7
13:02	5 psi	37786.3
13:04	5 psi	37792.8
13:05	5 psi	37800.5
13:06	5 psi	37811.0
13:07	5 psi	37825.0
13:08	5 psi	37842.5
13:09	5 psi	37863.3
13:10	5 psi	37887.6
13:11	5 psi	37915.0
13:12	5 psi	37944.0
13:13	5 psi	37974.3
13:14	5 psi	38005.0
13:15	5 psi	38036.5 31.5 gpm
13:16	5 psi	38068.5 32 gpm
13:17	5 psi	38100.5 32 gpm
13:18	5 psi	38132.5 32 gpm

Packer-Test Record

Page 2 of 2

Project Name: Crescent Jet Characterization Date: 12-1-05
 Field Representative: Mark Kautsky Borehole No.: 213 Total Depth: 30
 Depth to Water (TOC): 120' Borehole Cleaned? Yes No Date: 12-1-05
 Test Interval (BGL): from 20 to 30 ft. Swivel/Elbow Height (AGL) 6 ft.
 Conductor Pipe, Type, and Size: 10"/HX

Time	Gauge Pressure	Flow Meter Reading
13:20	10 psi	38203.0
13:21	10 psi	38243.0 40 gpm
13:22	10 psi	38283.0 40 gpm
13:23	10 psi	38323.0 40 gpm
X X	X X	X X
13:24	5 psi	38 out of water.
15:09	5 psi	38409
15:10	5 psi	38439 30 gpm
15:11	5 psi	38468 29 gpm
15:12	5 psi	38497 29 gpm
15:13	5 psi	38527 30 gpm
15:14	5 psi	38557 30 gpm
15:15	5 psi	38587 30 gpm
end of test borehole 213 20-30 ft.		
ML		

Stoller

DATE 1-23-06

JOB NAME Crescent Junction

PREPARED: M. Kautsky

REVIEWED:

SHEET NO: _____ OF _____

PACKER TEST ANALYSES

BOREHOLE : 213

Depth : 20-30 ft

Pressure (h_2) : 5 psi 11.6 ft

Unsaturated Zone Calculation:

Definitions:

 l = length of test section

$$T_u = u - D + H$$

 u = Thickness of Unsaturated Material D = distance from ground surface to bottom of test section

$$H = h_1 + h_2 - L$$

 L = head loss ; ignore if $Q < 4 \text{ gpm}$

$$X = \frac{H}{T_u} (100) ; \text{percent unsaturated material}$$

Reference Figure 17-6 U.S. Bureau of Rec. Earth Manual

$$l = 10 \text{ ft}$$

$$T_u = u - D + H = 120 \text{ ft} - 20 + 43.7 \text{ ft} = 143.7 \text{ ft}$$

$$\frac{T_u}{l} = \frac{143.7 \text{ ft}}{10 \text{ ft}} = \boxed{14.4}$$

$$H = h_1 + h_2 - L = 36 \text{ ft} + 11.6 \text{ ft} - 3.9 \text{ ft} = 43.7 \text{ ft}$$

$$X = \frac{H}{T_u} (100) = \frac{43.7 \text{ ft}}{143.7 \text{ ft}} (100) = \boxed{30}$$

WATER TESTING FOR PERMEABILITY

- Effective head, the difference in feet (m) between the elevation of the free water surface in the pipe and the elevation of the gauge plus the applied pressure. If a pressure transducer is used, the effective head in the test section is the difference in pressure before water is pumped into the test section and the pressure readings made during the test.

The following examples show some typical calculations using Methods 1 and 2 in the different zones shown in figure 17-5. Figure 17-6 shows the location of the zone 1 lower boundary for use in unsaturated materials.

Pressure permeability tests examples using Methods 1 and 2:

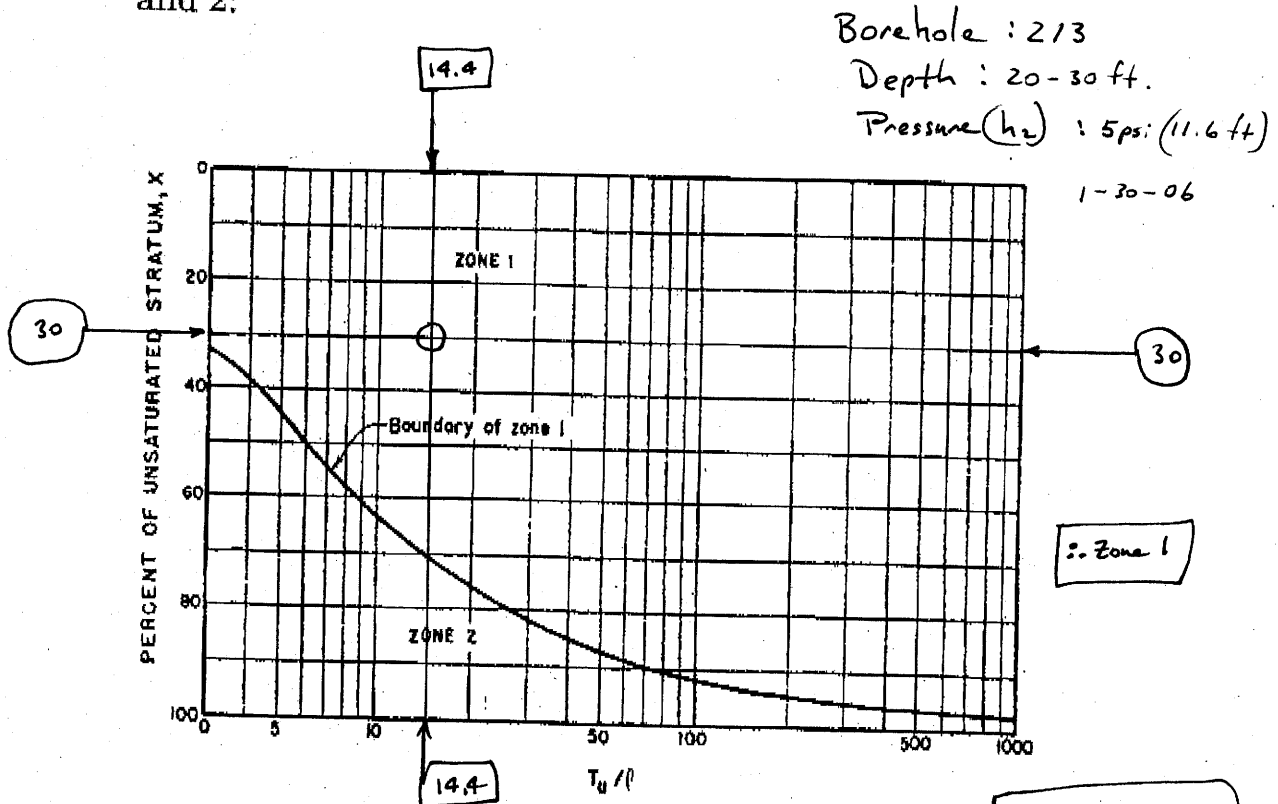

Figure 17-6.—Location of zone 1 lower boundary for use in unsaturated materials.

$$\frac{T_u}{l} = 14.4$$

$$X = 30$$

PRESSURE LOSS CURVE

Borehole 213
 Depth: 20-30 ft
 Pressure: 5 psi 1-30-06

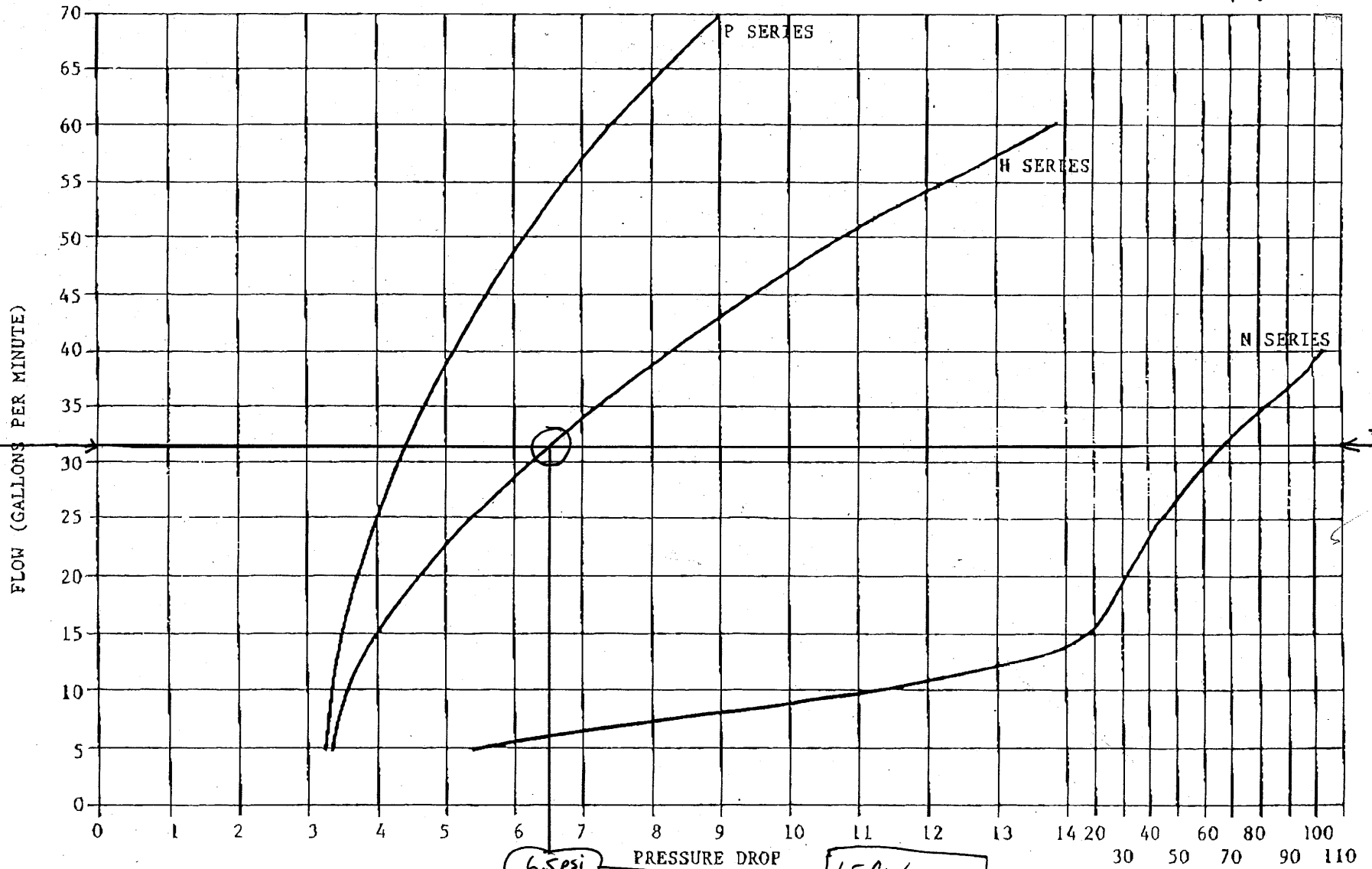

* TEST PERFORMED IN WATER TEMPERATURE OF 60°F (15.5°C)

* THIS CHART IS MEANT TO BE USED HAS A GUIDE ONLY. THE MEASUREMENTS WERE OBTAINED UNDER CONTROLLED LAB CONDITIONS AND ACTUAL FIELD CONDITIONS MAY VARY.

From: WIRELINE TYPE II service manual, Boat Langdon

T-115 P.29/32 F-001

8019741018

A-56

From-LAYNE CHRISTENSEN

Jul-25-05 04:21pm

WATER TESTING FOR PERMEABILITY

Borehole 213
Depth 20 - 30 ft.
pressure: 5 psi

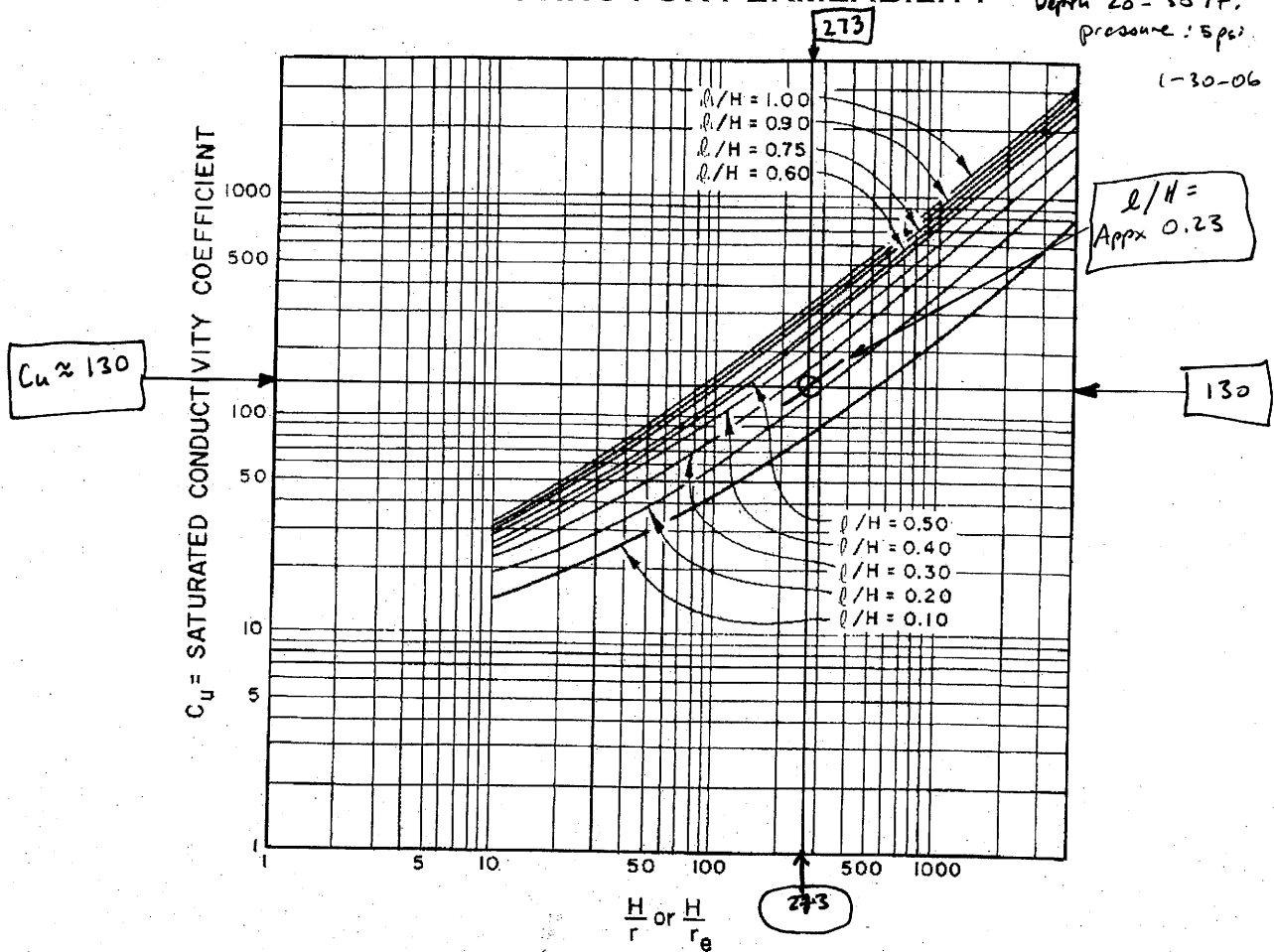

Figure 17-7.—Conductivity coefficients for permeability determination in unsaturated materials with partially penetrating cylindrical test wells.

Zone 2

Given: U , l , r , h_2 , Q , and L are as given in example 1, $D = 65$ feet, and $h_1 = 72$ feet

If the distance from the gauge to the bottom of the intake pipe is 62 feet, the total L is $(6.2)(0.76) = 4.7$ feet.

$$H = 72 + 57.8 - 4.7 = 125.1 \text{ feet}$$

Stoller

PACKER TEST SET-UP SHEET

JOB NO: _____ DATE: 1-30-06
 JOB NAME: Crescent Junction Site
 PREPARED: Mark Kautsky REVIEWED: _____
 SHEET NO: 1 OF _____
 Borehole 213
 Depth: 20-30 ft
 pressure: 11.6 ft (5psi)

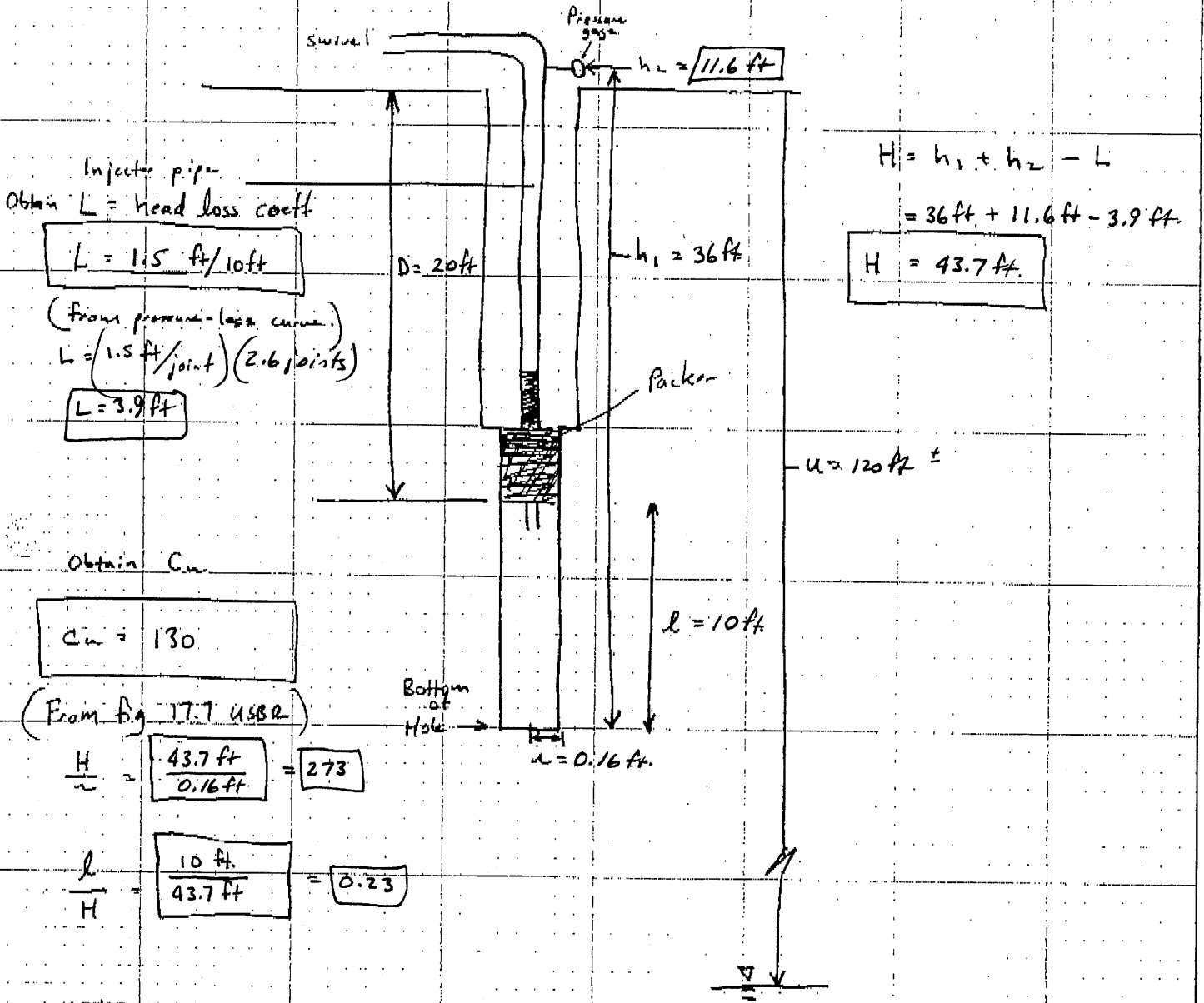

Injector pipe
 Obtain L = head loss coeff

$$L = 1.5 \text{ ft}/10 \text{ ft}$$

(From pressure-loss curve)
 $L = (1.5 \text{ ft}/\text{joint}) (2.6 \text{ joints})$

$$L = 3.9 \text{ ft}$$

$$H = h_1 + h_2 - L$$

$$= 36 \text{ ft} + 11.6 \text{ ft} - 3.9 \text{ ft}$$

$$H = 43.7 \text{ ft}$$

Obtain C_w

$$C_w = 130$$

(From Fig 17.7 USBR)

$$\frac{H}{r} = \frac{43.7 \text{ ft}}{0.16 \text{ ft}} = 273$$

$$\frac{l}{H} = \frac{10 \text{ ft}}{43.7 \text{ ft}} = 0.23$$

Calculate K :

Method 1,
 Zone 1,
 USBR

$$K = \frac{Q}{C_w r H} = \frac{(32 \text{ gal}/\text{min}) \left(\frac{1440 \text{ min}}{\text{day}} \right) \left(\frac{1 \text{ ft}^3}{7.48 \text{ gal}} \right)}{(130) (0.16 \text{ ft}) (43.7 \text{ ft})}$$

$$K = 6.8 \text{ ft}/\text{d}$$

$$K = 2.4 \times 10^{-3} \text{ cm}/\text{s}$$

Stoller

JOB NAME: Crescent Junction

PREPARED: M. Kautsky

REVIEWED:

SHEET NO: _____ OF _____

PACKER TEST ANALYSES

BOREHOLE: 213

Depth: 20-30 ft.

Pressure (h_2): 10 psi (23.1 ft)

Unsaturated Zone Calculation:

Definitions:

 l = length of test section $T_u = u - D + H$ u = Thickness of Unsaturated Material D = distance from ground surface to bottom of test section $H = h_1 + h_2 - L$ L = head loss; ignore if $Q < 4 \text{ gpm}$ $X = \frac{H}{T_u} (100)$; percent unsaturated material

Reference Figure 17-6 U.S. Bureau of Rec. Earth Manual

$$l = 10 \text{ ft}$$

$$T_u = u - D + H = 120 \text{ ft} - 20 \text{ ft} + 54.2 \text{ ft} = \boxed{154.2 \text{ ft}}$$

$$\frac{T_u}{l} = \frac{154.2 \text{ ft}}{10 \text{ ft}} = \boxed{15.4}$$

$$H = h_1 + h_2 - L = 54.2 \text{ ft}$$

$$X = \frac{H}{T_u} (100) = \frac{54.2 \text{ ft}}{154.2 \text{ ft}} \times (100) = \boxed{35}$$

PRESSURE LOSS CURVE

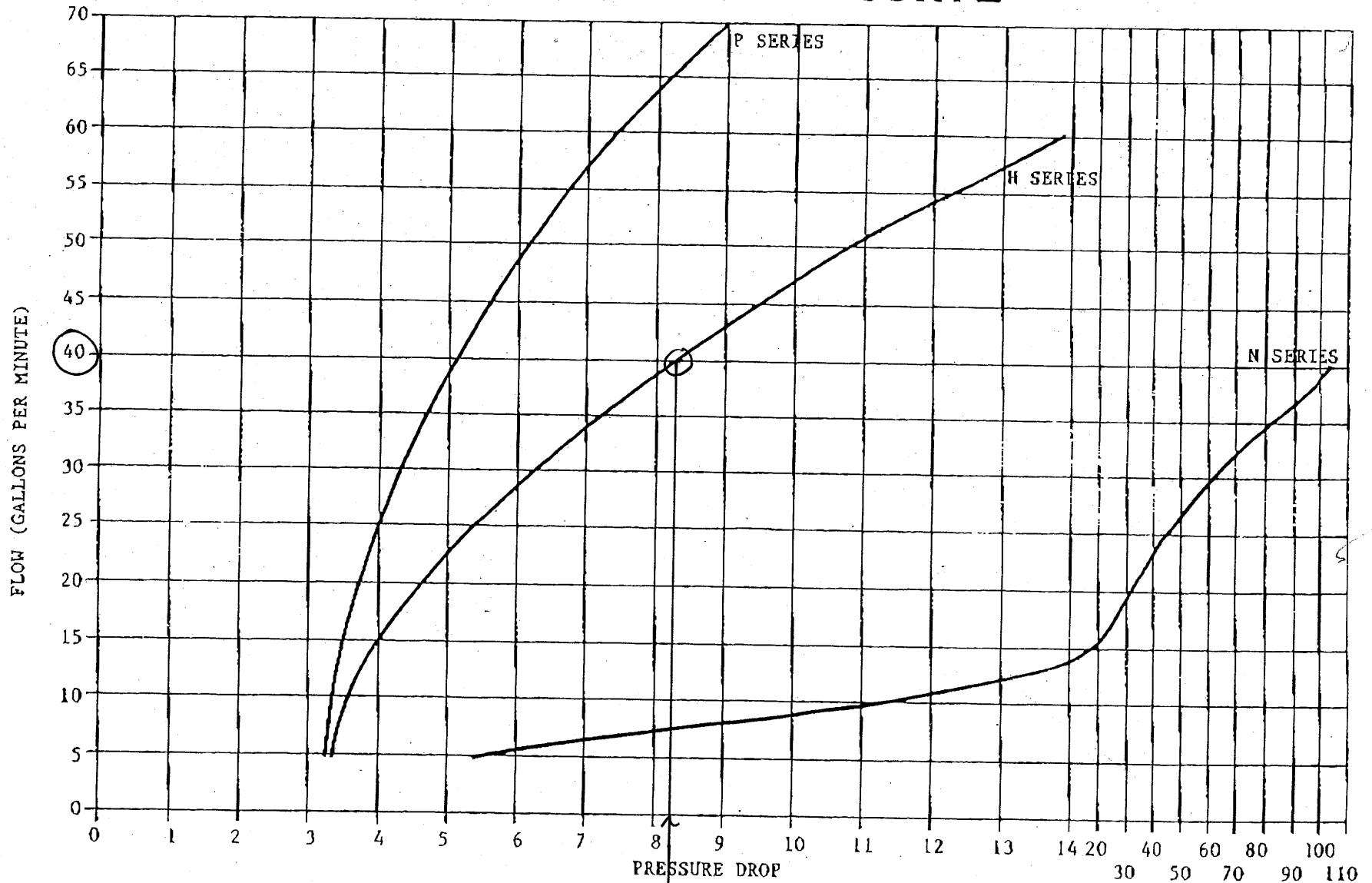

* TEST PERFORMED IN WATER TEMPERATURE OF 60°F (15.5°C)
 * THIS CHART IS MEANT TO BE USED HAS A GUIDE ONLY. THE MEASUREMENTS WERE OBTAINED UNDER CONTROLLED LAB CONDITIONS AND ACTUAL FIELD CONDITIONS MAY VARY.

From: WIRELINE TYPE II service manual, *Boart Longyear*.

$8.2 \text{ psi}/100\text{ft} = 1.9 \text{ ft}/\text{joint}$

*Booth 213
 depth: 20-30 ft
 Pressure: 10 psi
 1-30-06*

Jul-25-05 04:21pm From-LAYNE CHRISTENSEN 8010741018 T-115 P.28/32 F-001 A-60

WATER TESTING FOR PERMEABILITY

- Effective head, the difference in feet (m) between the elevation of the free water surface in the pipe and the elevation of the gauge plus the applied pressure. If a pressure transducer is used, the effective head in the test section is the difference in pressure before water is pumped into the test section and the pressure readings made during the test.

The following examples show some typical calculations using Methods 1 and 2 in the different zones shown in figure 17-5. Figure 17-6 shows the location of the zone 1 lower boundary for use in unsaturated materials.

Pressure permeability tests examples using Methods 1 and 2:

Borehole : 213
Depth : 20-30ft
Pressure (h_2) : 10 psi

1-30-06

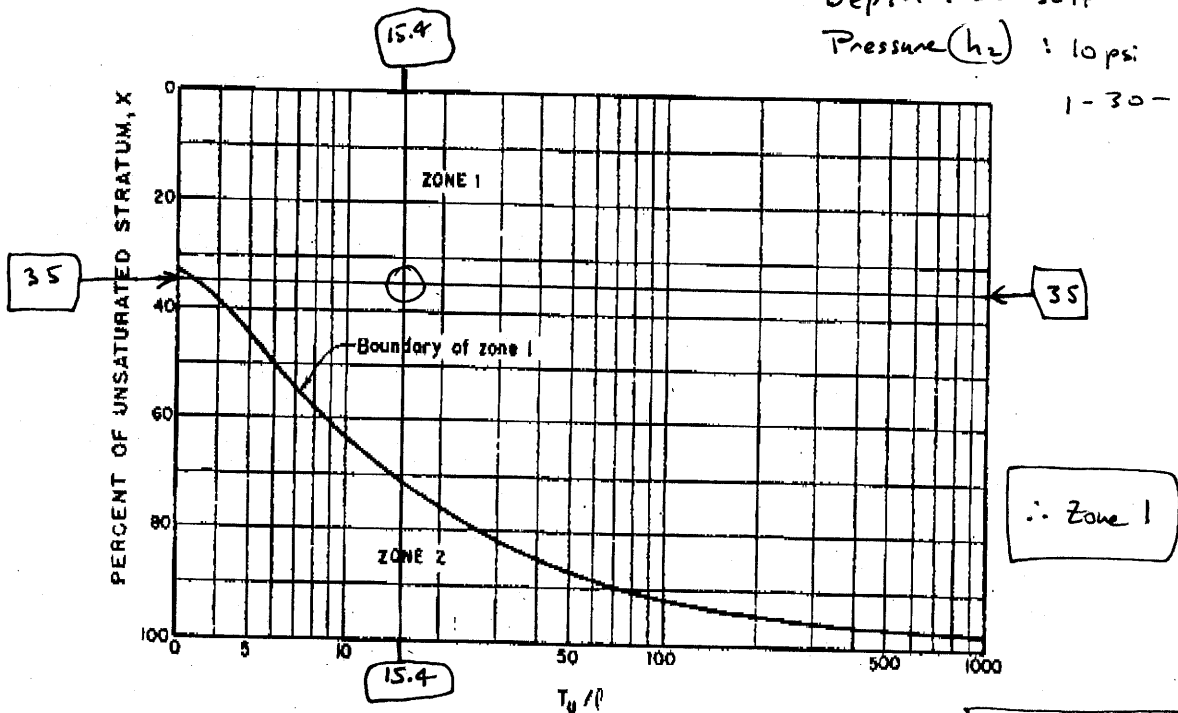

Figure 17-6.—Location of zone 1 lower boundary for use in unsaturated materials.

$$\frac{T_u}{l} = 15.4$$

$$X = 35$$

WATER TESTING FOR PERMEABILITY

Borehole 213
Depth 20-30 ft.
Pressure: 10 psi
1-30-06

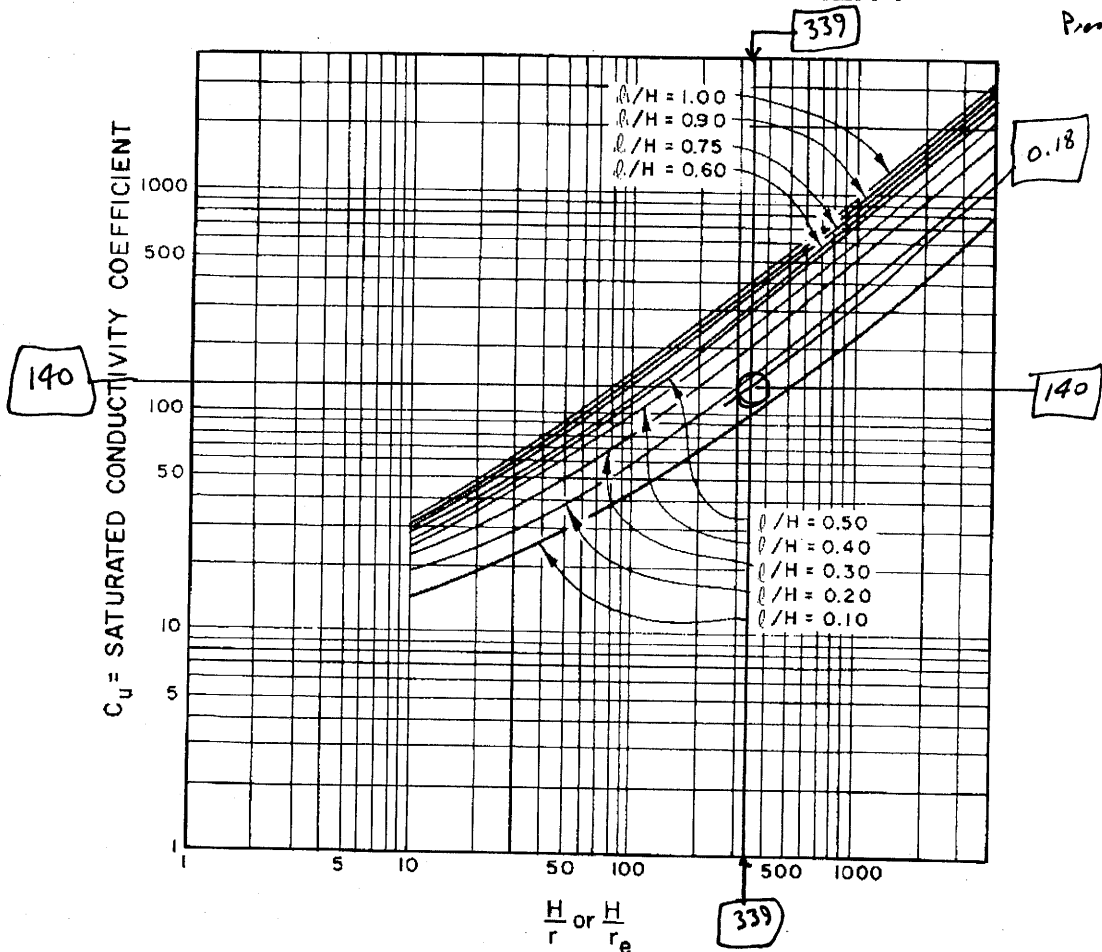

Figure 17-7.—Conductivity coefficients for permeability determination in unsaturated materials with partially penetrating cylindrical test wells.

Zone 2

Given: U , l , r , h_2 , Q , and L are as given in example 1, $D = 65$ feet, and $h_1 = 72$ feet

If the distance from the gauge to the bottom of the intake pipe is 62 feet, the total L is $(6.2)(0.76) = 4.7$ feet.

$$H = 72 + 57.8 - 4.7 = 125.1 \text{ feet}$$

Stoller

PACKER TEST SET-UP SHEET

JOB NO: _____ DATE: 1-30-06

JOB NAME: Crescent Junction Site

PREPARED: Mark Kautsky

REVIEWED: Borehole 213

SHEET NO: 1 OF _____

20-30 ft.

pressure: 10 psi

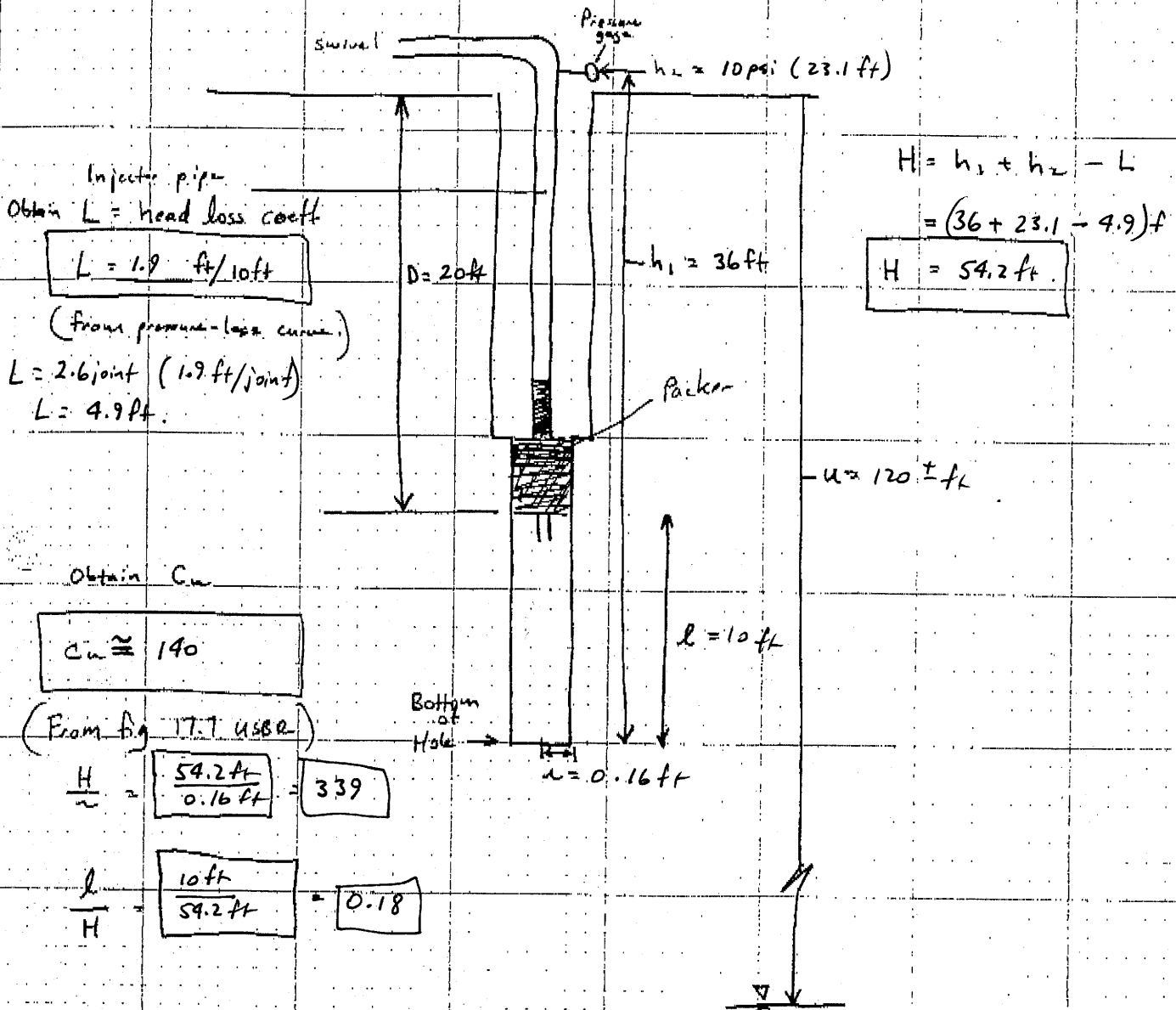

Injector pipe
Obtain $L =$ head loss coeff
 $L = 1.9 \text{ ft}/10\text{ft}$
(From pressure-loss curve)
 $L = 2.6 \text{ joint } (1.9 \text{ ft}/\text{joint})$
 $L = 4.9 \text{ ft}$

$$H = h_1 + h_2 - L$$

$$= (36 + 23.1 - 4.9) \text{ ft}$$

$$H = 54.2 \text{ ft}$$

Obtain C_w

$$C_w \approx 140$$

(From Fig 17.7 USBR)

$$\frac{H}{r} = \frac{54.2 \text{ ft}}{0.16 \text{ ft}} = 339$$

$$\frac{l}{H} = \frac{10 \text{ ft}}{54.2 \text{ ft}} = 0.18$$

Calculate K :

Method 1,
Zone 1,
USBR

$$K = \frac{Q}{C_w r H} = \frac{\left(\frac{40 \text{ gal}}{\text{min}}\right) \left(\frac{1440 \text{ min}}{\text{day}}\right) \left(\frac{1 \text{ ft}^3}{7.48 \text{ gal}}\right)}{(140) (0.16 \text{ ft}) (54.2 \text{ ft})}$$

$$K = 6.3 \text{ ft/d}$$

$$K = 2.2 \times 10^{-3} \text{ cm/s}$$

79-V

Jul-25-05 04:21pm From-LAYNE CHRISTENSEN

8019741018

T-115 P.29/32 F-001

PRESSURE LOSS CURVE

Borehole 213
Depth: 20-30 ft
Pressure 5 psi (retort)
1-30-06

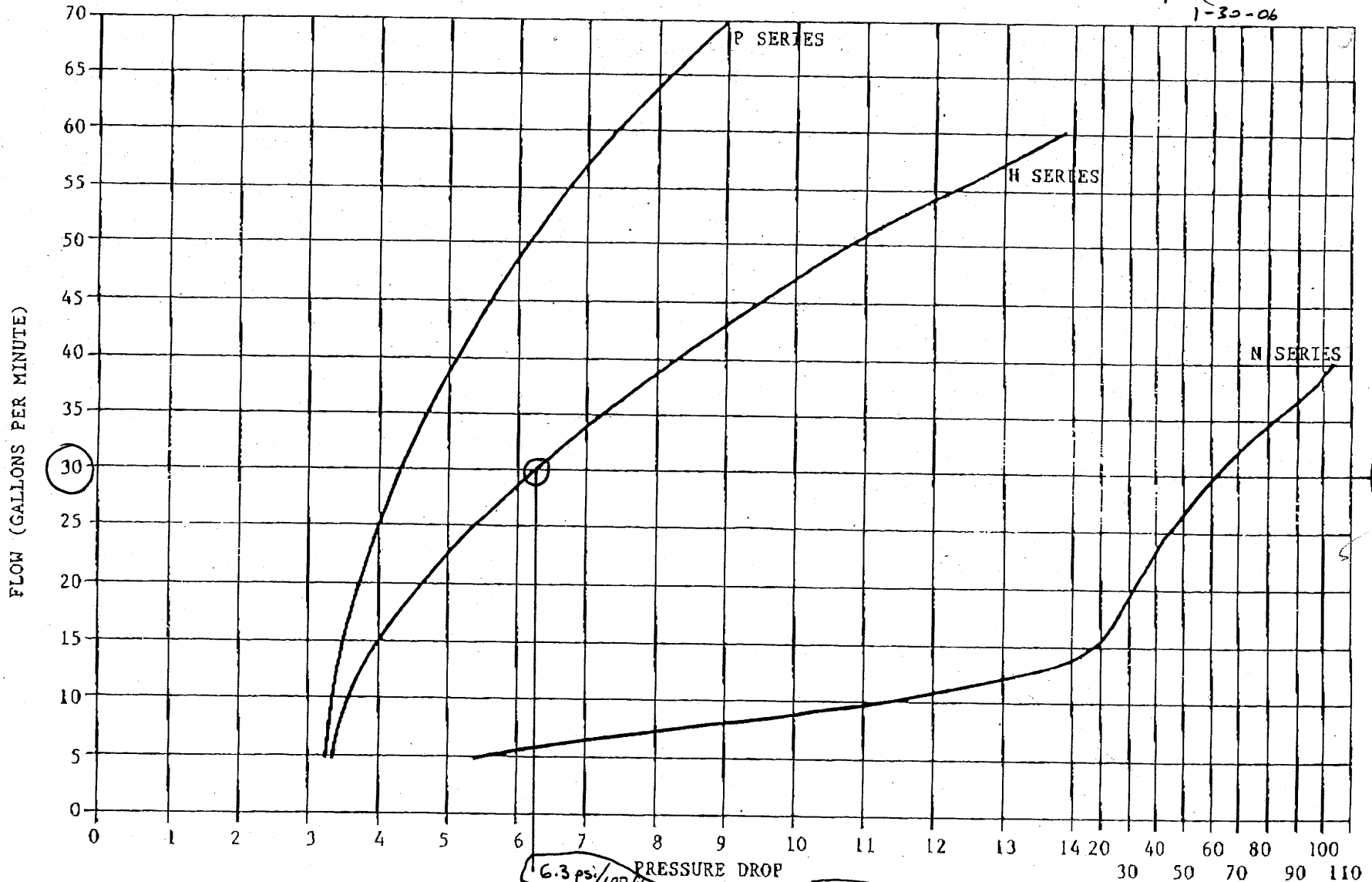

6.3 psi/100ft PRESSURE DROP
1.5 ft/10 ft joint

- * TEST PERFORMED IN WATER TEMPERATURE OF 60°F (15.5°C)
- * THIS CHART IS MEANT TO BE USED HAS A GUIDE ONLY. THE MEASUREMENTS WERE OBTAINED UNDER CONTROLLED LAB CONDITIONS AND ACTUAL FIELD CONDITIONS MAY VARY.

From: WIRELINE TYPE II service manual, Bost Longyear.

Borehole 213
Depth: 20-30
Pressure: 5 psi (retort)
1-30-06

Stoller

PACKER TEST SET-UP SHEET

JOB NO: _____ DATE: 1-30-06

JOB NAME: Crescent Junction Site

PREPARED: Mark Kautsky REVIEWED: _____

SHEET NO: 1 OF _____ Borehole 213
Depth: 20-30 ft.

pressure 5 psi (retest)

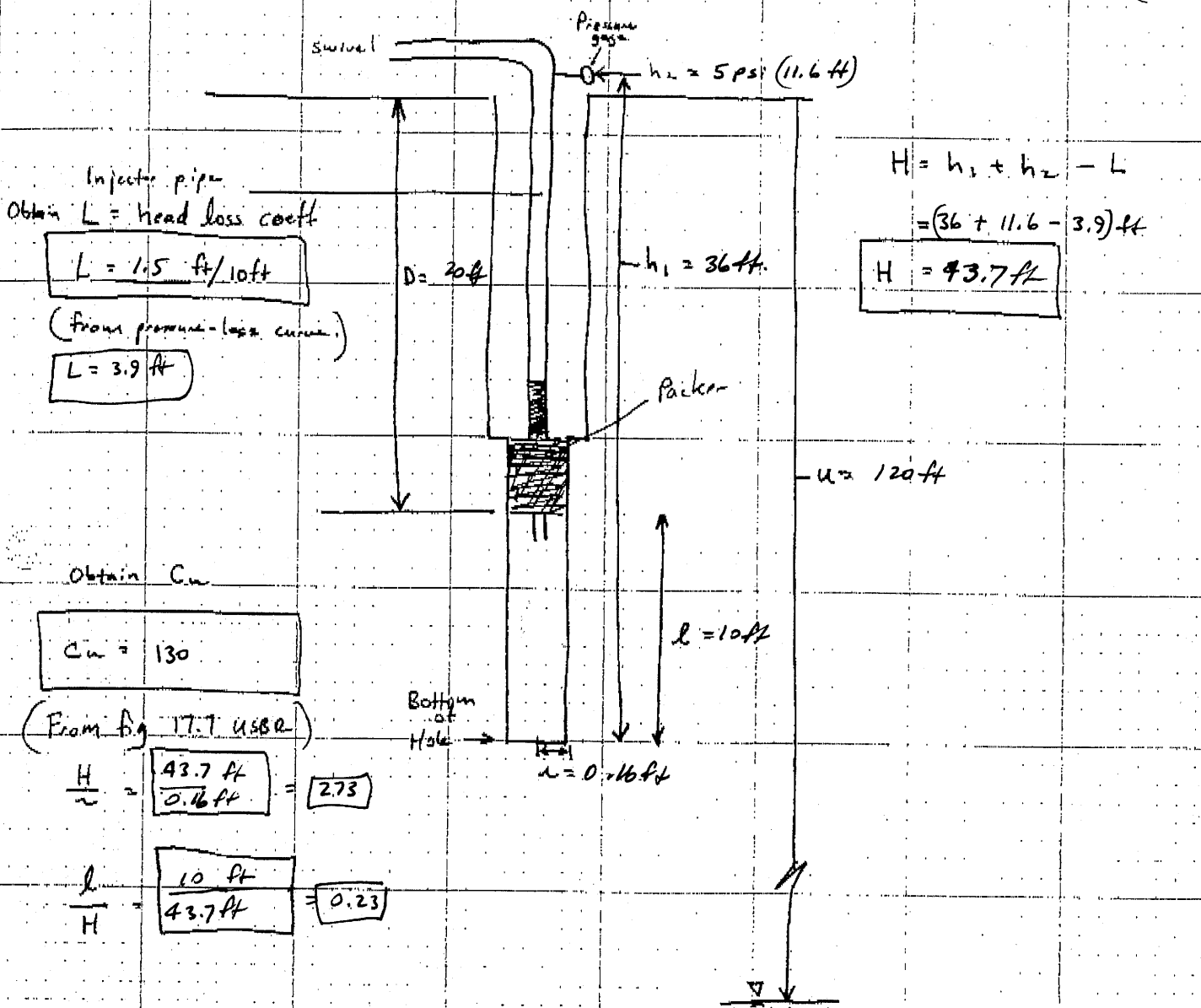

Injector pipe
Obtain $L =$ head loss coeff
 $L = 1.5 \text{ ft}/10 \text{ ft}$
 (From pressure-loss curve.)
 $L = 3.9 \text{ ft}$

$$H = h_1 + h_2 - L$$

$$= (36 + 11.6 - 3.9) \text{ ft}$$

$$H = 43.7 \text{ ft}$$

Obtain C_w

$$C_w = 130$$

(From Fig 17.7 USBR)

$$\frac{H}{r} = \frac{43.7 \text{ ft}}{0.16 \text{ ft}} = 273$$

$$\frac{l}{H} = \frac{10 \text{ ft}}{43.7 \text{ ft}} = 0.23$$

Calculate K :

Method 1,
Zone 1,
USBR

$$K = \frac{Q}{C_w r H} = \frac{(30 \text{ gal/min}) \left(\frac{1440 \text{ min}}{d}\right) \left(\frac{1 \text{ ft}^3}{7.48 \text{ gal}}\right)}{(130) (0.16 \text{ ft}) (43.7 \text{ ft})}$$

$$K = 6.4 \text{ ft/d}$$

$$K = 2.2 \times 10^{-3} \text{ cm/s}$$

Packer-Test Record

Page 1 of 1

Project Name: Crescent Junction Characterization Date: 12-02-05
 Field Representative: Mark Kautsky Borehole No.: 213 Total Depth: 40
 Depth to Water (TOC): 120 ± Borehole Cleaned? Yes No Date: 12-02-05
 Test Interval (BGL): from 30 to 40 ft. Swivel/Elbow Height (AGL) 6 ft
 Conductor Pipe, Type, and Size: HQ/HX

Time	Gauge Pressure (psi)	Flow Meter Reading
09:30	5	38660
09:31	5	38697 37 gpm
09:32	5	38736 39 gpm
09:33	5	38775 39 gpm
09:44 0934	5	38815 40 gpm
09:45 0935	5	38854 39 gpm
0936	5	38893 39 gpm
<hr/>		
0937	10	38934
0938	10	38979 45 gpm
0939	10	39023 44 gpm
0940	10	39068 45 gpm
09:41	10	390 39113 45 gpm
09:42	10	39158 45 gpm
<hr/>		
0943	5	39198
0944	5	39236 38 gpm
0945	5	39275 39 gpm
0946	5	39314 39 gpm
0947	5	end test: out of water

Stoller

PROJECT

DATE 1-23-06

JOB NAME Crescent Junction

PREPARED: M. Kautsley

REVIEWED:

SHEET NO. OF

PACKER TEST ANALYSES

BOREHOLE : 213

Depth : 30-40ft

Pressure (h_2) : 5psi (11.6 ft)

Unsaturated Zone Calculation:

Definitions:

 L = length of test section

$$T_u = U - D + H$$

 U = Thickness of Unsaturated Material D = distance from ground surface to bottom of test section

$$H = h_1 + h_2 - L$$

 L = head loss ; ignore if $Q < 4 \text{ gpm}$

$$X = \frac{H}{T_u} (100) ; \text{percent unsaturated material}$$

Reference Figure 17-6 U.S. Bureau of Rec. Earth Manual

$$L = 10 \text{ ft}$$

$$T_u = U - D + H = 120 \text{ ft} - 30 \text{ ft} + 50.8 \text{ ft} = \boxed{141 \text{ ft}}$$

$$\frac{T_u}{L} = \frac{141}{10} = \boxed{14.1}$$

$$H = h_1 + h_2 - L = (46 + 11.6 - 6.8) \text{ ft} = 50.8 \text{ ft}$$

$$X = \frac{H}{T_u} (100) = \frac{50.8 \text{ ft}}{141} (100) = \boxed{36}$$

WATER TESTING FOR PERMEABILITY

- Effective head, the difference in feet (m) between the elevation of the free water surface in the pipe and the elevation of the gauge plus the applied pressure. If a pressure transducer is used, the effective head in the test section is the difference in pressure before water is pumped into the test section and the pressure readings made during the test.

The following examples show some typical calculations using Methods 1 and 2 in the different zones shown in figure 17-5. Figure 17-6 shows the location of the zone 1 lower boundary for use in unsaturated materials.

Pressure permeability tests examples using Methods 1 and 2:

Borehole : 213
 Depth : 30-40 ft.
 Pressure (h_2) : 5psi (11.6 ft)

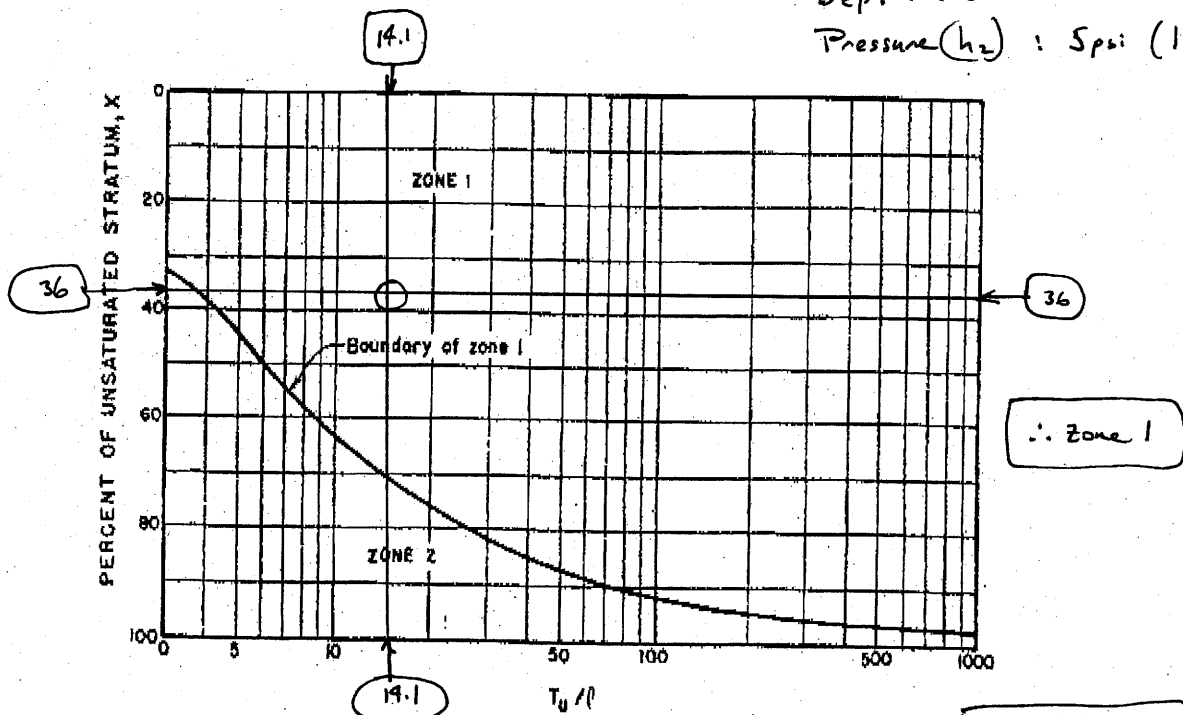
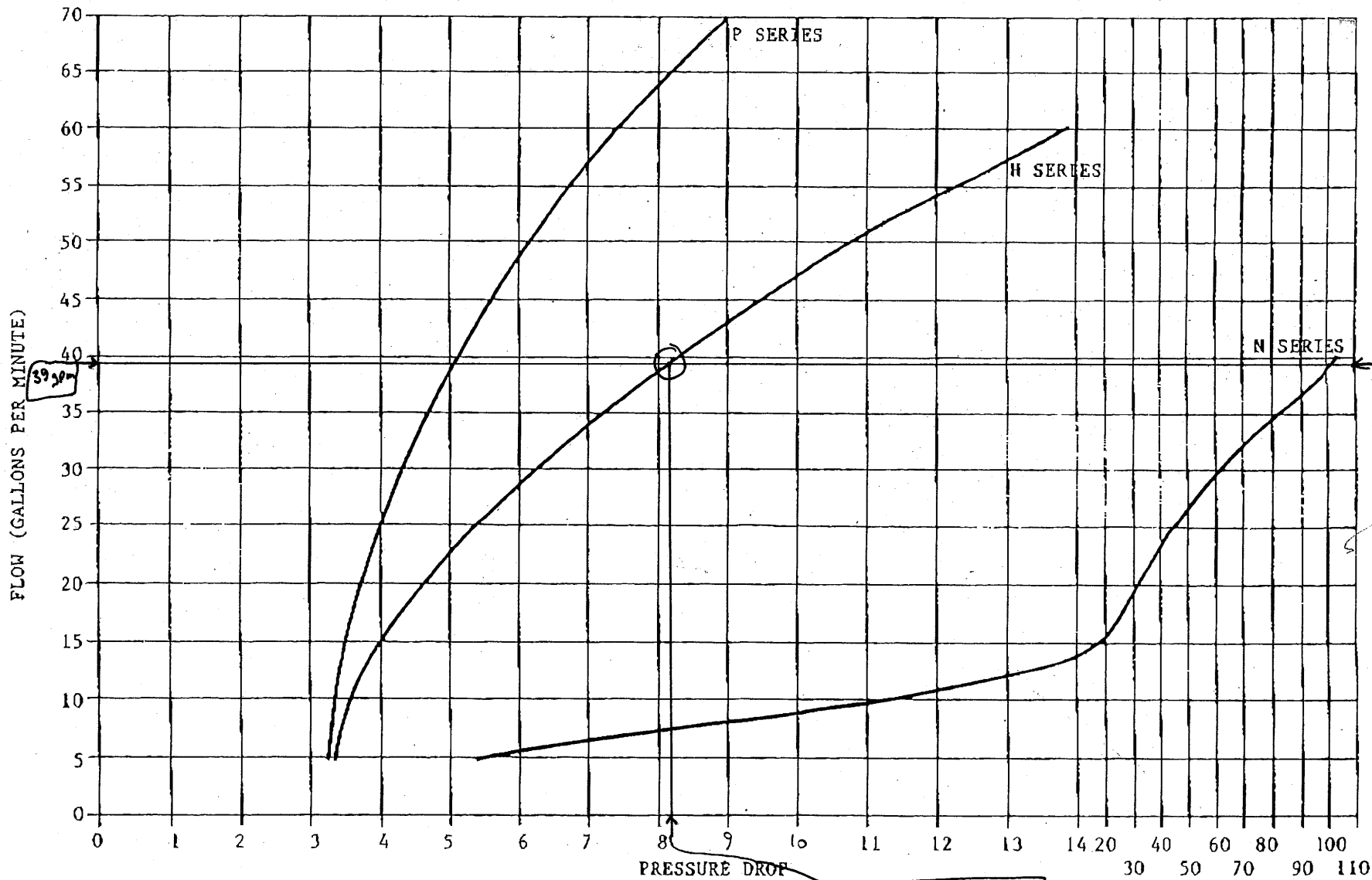

Figure 17-6.—Location of zone 1 lower boundary for use in unsaturated materials.

$$\frac{T_u}{l} = 14.1$$

$$X = 36$$

PRESSURE LOSS CURVE



* TEST PERFORMED IN WATER TEMPERATURE OF 60°F (15.5°C)

* THIS CHART IS MEANT TO BE USED HAS A GUIDE ONLY. THE MEASUREMENTS WERE OBTAINED UNDER CONTROLLED LAB CONDITIONS AND ACTUAL FIELD CONDITIONS MAY VARY.

8.2 psi/100 ft

1.9 ft/10-ft joint

From: WIRELINE TYPE II service manual, Boat Longyear

Handhole 213
Depth: 30-40 ft
Pressure: 5 psi
1-30-06

F-001

P. 28/32

8018741018

A-69

From-LAYNE CHRISTENSEN

Jul-25-05 04:21pm

WATER TESTING FOR PERMEABILITY

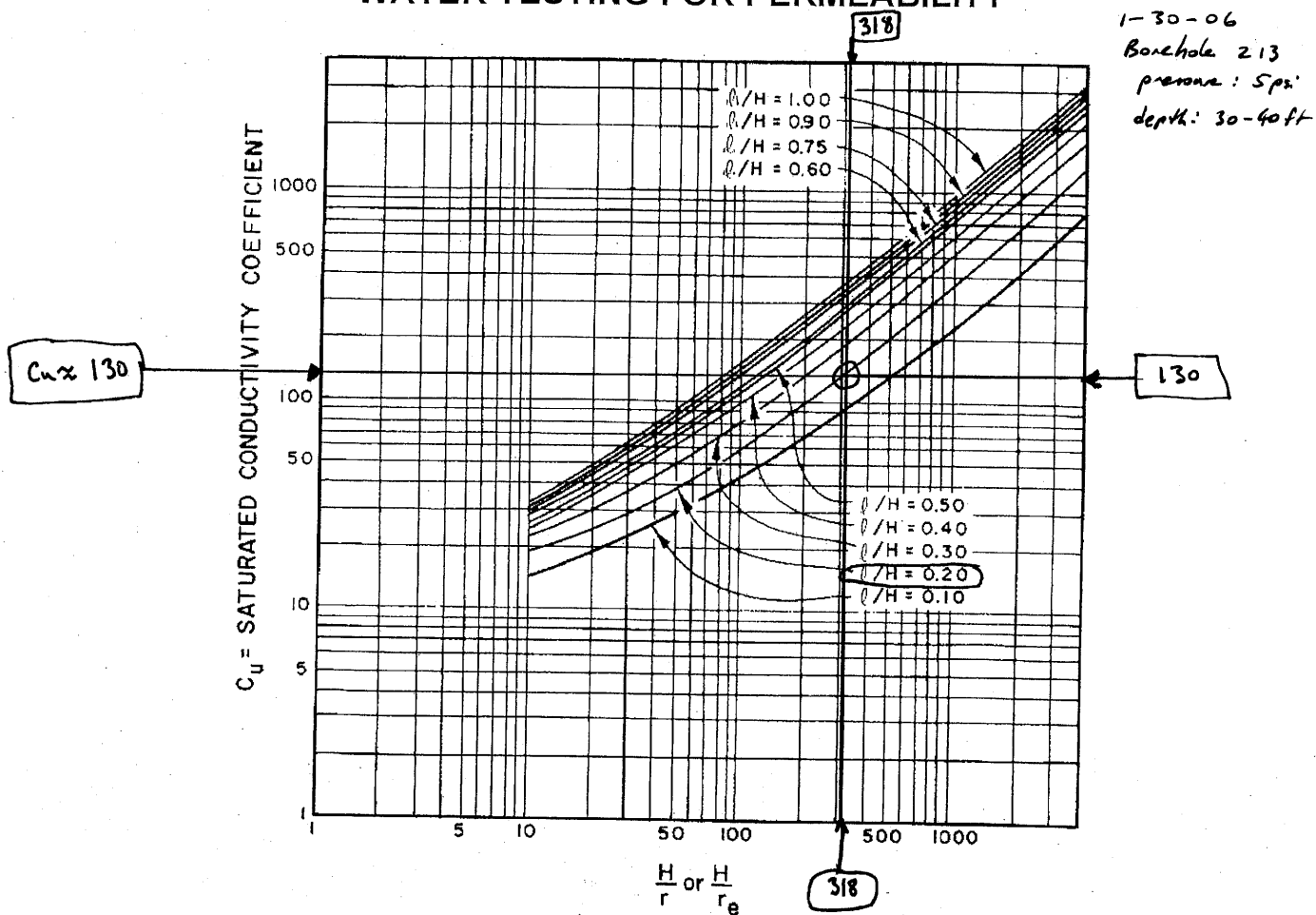

Figure 17-7.—Conductivity coefficients for permeability determination in unsaturated materials with partially penetrating cylindrical test wells.

Zone 2

Given: U , l , r , h_2 , Q , and L are as given in example 1, $D = 65$ feet, and $h_1 = 72$ feet

If the distance from the gauge to the bottom of the intake pipe is 62 feet, the total L is $(6.2)(0.76) = 4.7$ feet.

$$H = 72 + 57.8 - 4.7 = 125.1 \text{ feet}$$

Stoller

PACKER TEST SET-UP SHEET

JOB NO.: _____ DATE: 1-30-06
 JOB NAME: Crescent Junction Site
 PREPARED: Mark Kantsky REVIEWED: _____
 SHEET NO.: 1 OF 1
 Borehole 213
 Depth: 30 - 40 ft.
 Pressure: 11.6 ft (5 psi)

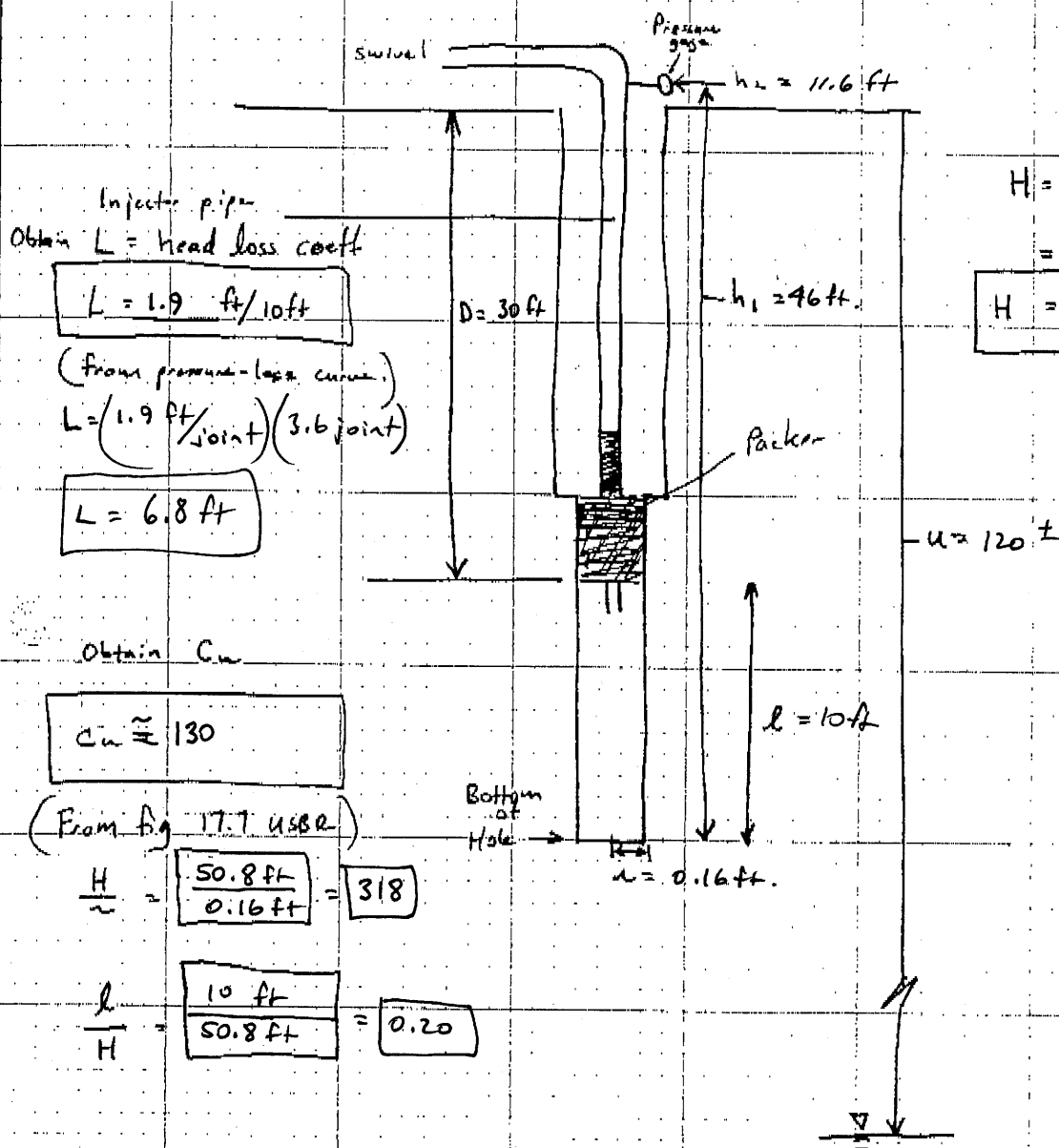

$$H = h_1 + h_2 - L$$

$$= (46 + 11.6 - 6.8) \text{ ft}$$

$$H = 50.8 \text{ ft}$$

Injector pipe
 Obtain L = head loss coeff

$$L = 1.9 \text{ ft/10ft}$$

(From pressure-loss curve)

$$L = (1.9 \text{ ft/joint}) (3.6 \text{ joint})$$

$$L = 6.8 \text{ ft}$$

Obtain C_u

$$C_u \approx 130$$

(From Fig. 17.7 USBR)

$$\frac{H}{u} = \frac{50.8 \text{ ft}}{120 \text{ ft}} = 0.423$$

$$\frac{l}{H} = \frac{10 \text{ ft}}{50.8 \text{ ft}} = 0.20$$

Calculate K :

Method 1,
 Zone 1,
 USBR

$$K = \frac{Q}{C_u u H} = \frac{\left(\frac{39 \text{ gal}}{\text{min}}\right) \left(\frac{1440 \text{ min}}{d}\right) \left(\frac{1 \text{ ft}^3}{7.48 \text{ gal}}\right)}{(130) (0.16 \text{ ft}) (50.8 \text{ ft})}$$

$$K = 7.1 \text{ ft/d}$$

$$K = 2.5 \times 10^{-3} \text{ cm/s}$$

Stoller

DATE: 1-23-06

JOB NAME: Crescent Junction

PREPARED: M. Kautsky

REVIEWED:

SHEET NO: 01 OF

PACKER TEST ANALYSES

BOREHOLE: 213

Depth: 30 - 40 ft

Pressure (h_2): 10 psi (23.1 ft)

Unsaturated Zone Calculation:

Definitions:

 l = length of test section

$$T_u = U - D + H$$

 U = Thickness of Unsaturated Material D = distance from ground surface to bottom of test section

$$H = h_1 + h_2 - L$$

 L = head loss; ignore if $Q < 4$ gpm

$$X = \frac{H}{T_u} (100); \text{ percent unsaturated material}$$

Reference Figure 17-6 U.S. Bureau of Rec. Earth Manual

$$l = 10$$

$$T_u = U - D + H = (120 - 30 + 61.3) \text{ ft} = 151$$

$$\frac{T_u}{l} = \left(\frac{151 \text{ ft}}{10 \text{ ft}} \right) = \boxed{15.1}$$

$$H = h_1 + h_2 - L = \boxed{61.3 \text{ ft}}$$

$$X = \frac{H}{T_u} (100) = \frac{61.3 \text{ ft}}{151 \text{ ft}} \times 100\% \approx \boxed{41}$$

WATER TESTING FOR PERMEABILITY

- Effective head, the difference in feet (m) between the elevation of the free water surface in the pipe and the elevation of the gauge plus the applied pressure. If a pressure transducer is used, the effective head in the test section is the difference in pressure before water is pumped into the test section and the pressure readings made during the test.

The following examples show some typical calculations using Methods 1 and 2 in the different zones shown in figure 17-5. Figure 17-6 shows the location of the zone 1 lower boundary for use in unsaturated materials.

Pressure permeability tests examples using Methods 1 and 2:

Borehole : 213
 Depth : 30-40 ft.
 Pressure (h_2) : 10 psi (23.1 ft)

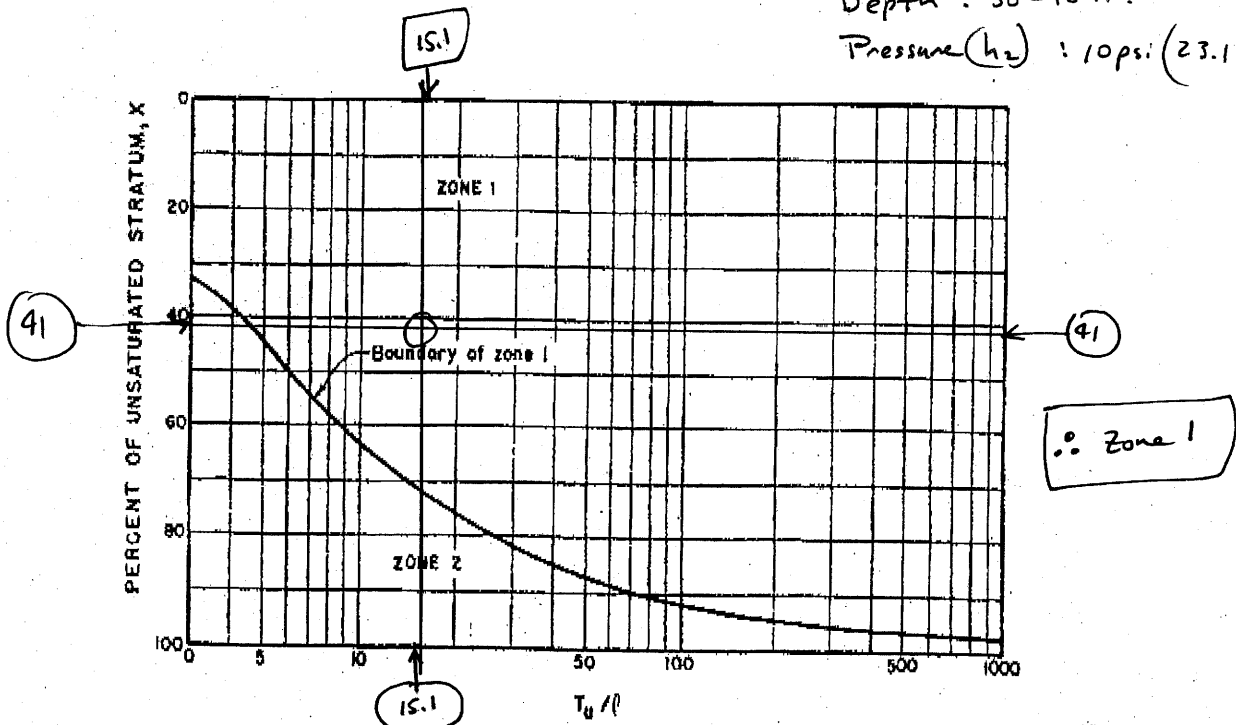
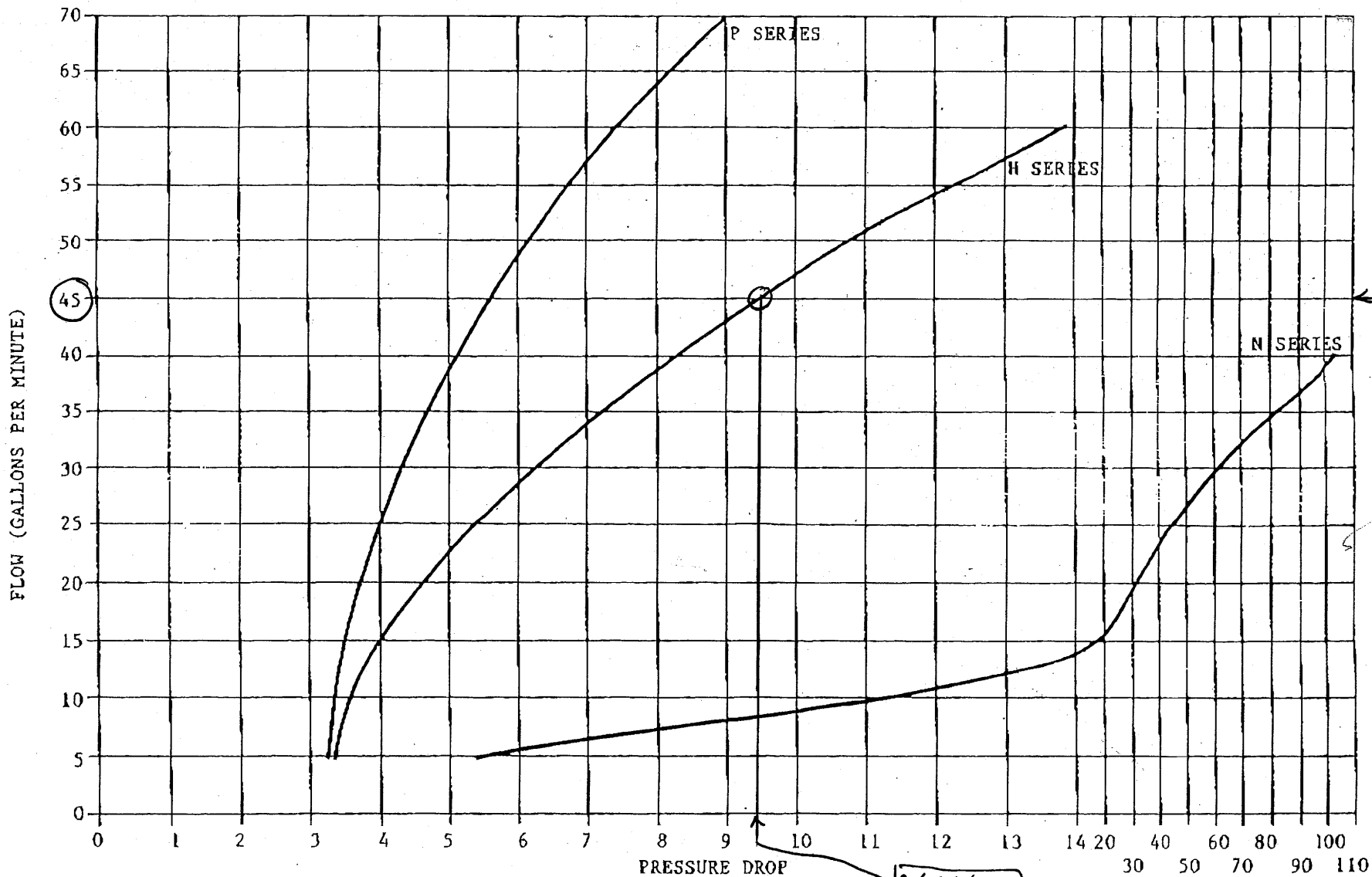

Figure 17-6.—Location of zone 1 lower boundary for use in unsaturated materials.

$$\frac{T_u}{l} = 15.1$$

$$X = 41$$

PRESSURE LOSS CURVE



* TEST PERFORMED IN WATER TEMPERATURE OF 60°F (15.5°C)

* THIS CHART IS MEANT TO BE USED HAS A GUIDE ONLY. THE MEASUREMENTS WERE OBTAINED UNDER CONTROLLED LAB CONDITIONS AND ACTUAL FIELD CONDITIONS MAY VARY.

9.4 psi/100 ft

2.2 ft/joint

From: WIRELINE TYPE II service manual, Boat Longyear.

Boreshole 213
Depth 30-90 ft
Pressure 10 psi
1-30-06

HL-V

From-LAYNE CHRISTENSEN

Jul-25-05 04:21pm

8019741018

T-115 P.28/32

F-001

WATER TESTING FOR PERMEABILITY

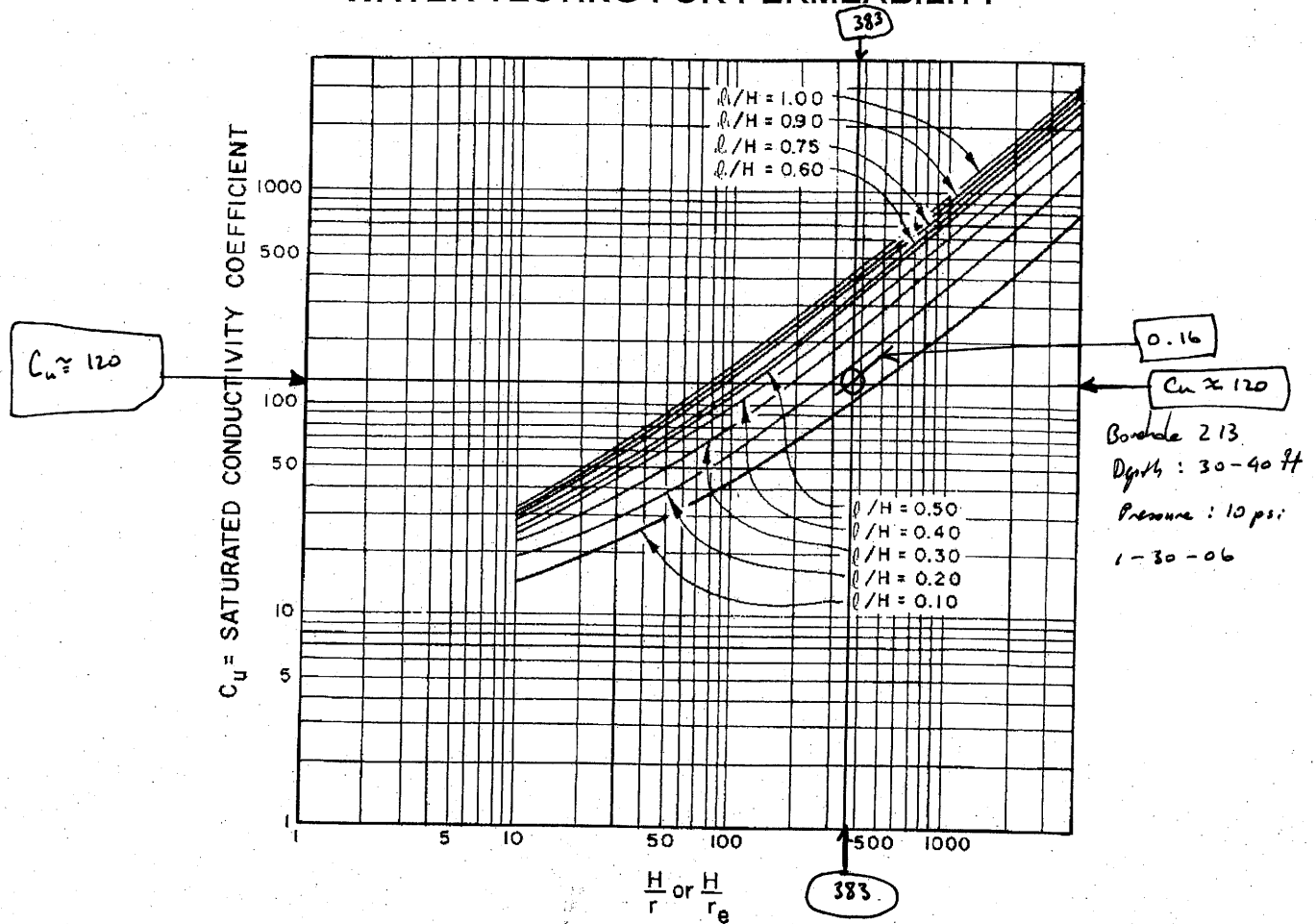

Figure 17-7.—Conductivity coefficients for permeability determination in unsaturated materials with partially penetrating cylindrical test wells.

Zone 2

Given: U , l , r , h_2 , Q , and L are as given in example 1, $D = 65$ feet, and $h_1 = 72$ feet

If the distance from the gauge to the bottom of the intake pipe is 62 feet, the total L is $(6.2)(0.76) = 4.7$ feet.

$$H = 72 + 57.8 - 4.7 = 125.1 \text{ feet}$$

Stoller

PACKER TEST SET-UP SHEET

Zone 1

JOB NO: _____ DATE: 1-30-06
 JOB NAME: Crescent Junction Site
 PREPARED: Mark Kautsky REVIEWED: _____
 SHEET NO: 1 OF _____
 Batch # 213
 Depth 30-40 ft.
 Pressure: (10. psi)

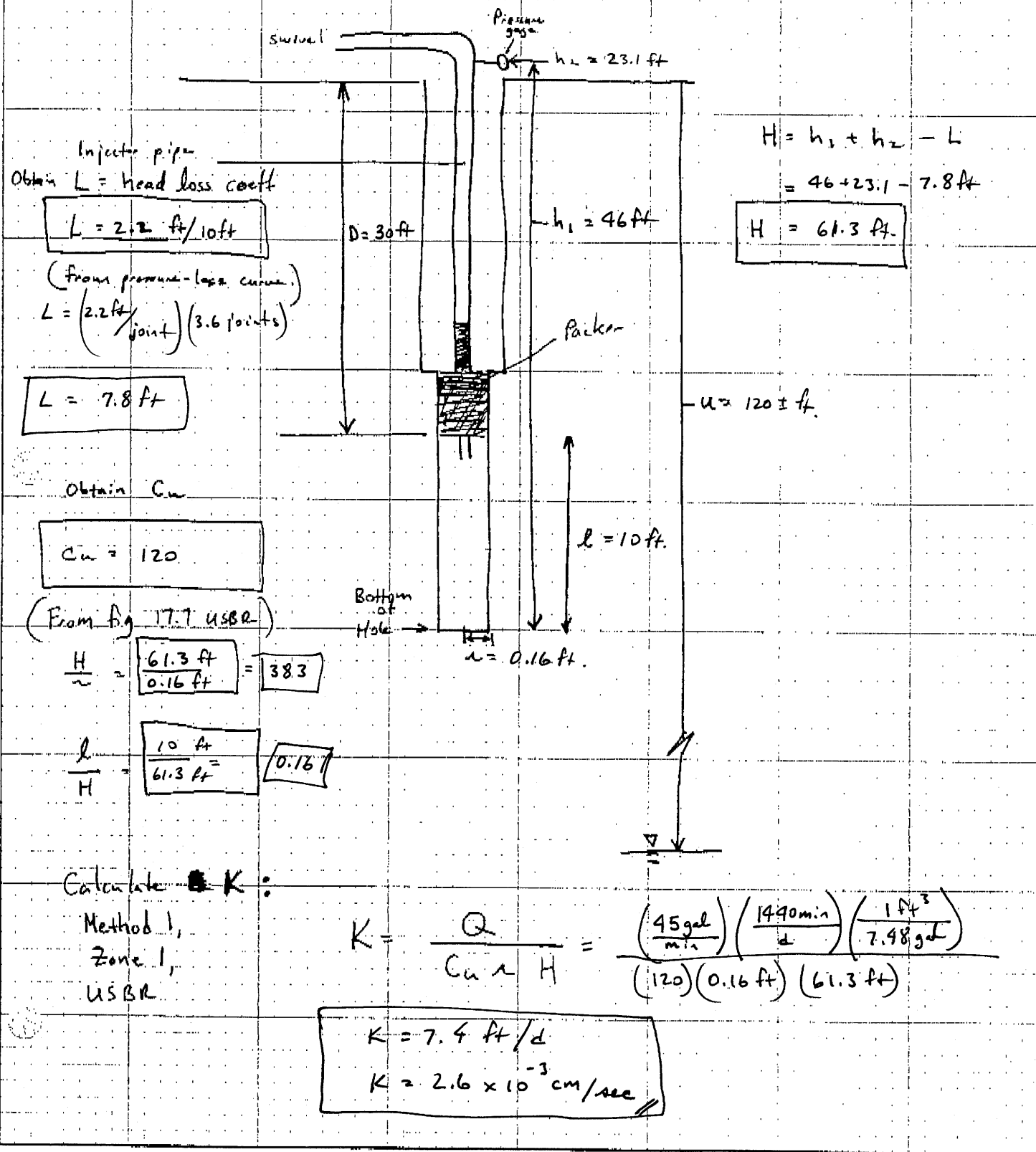

Injector pipe
 Obtain L = head loss coeff
 $L = 2.2 \text{ ft}/10 \text{ ft}$
 (From pressure-loss curve)
 $L = (2.2 \text{ ft}/\text{joint}) (3.6 \text{ joints})$
 $L = 7.8 \text{ ft}$

$$H = h_1 + h_2 - L$$

$$= 46 + 23.1 - 7.8 \text{ ft}$$

$$H = 61.3 \text{ ft}$$

Obtain C_w
 $C_w = 120$

(From Fig. 17.7 USBR)

$$\frac{H}{r} = \frac{61.3 \text{ ft}}{0.16 \text{ ft}} = 383$$

$$\frac{l}{H} = \frac{10 \text{ ft}}{61.3 \text{ ft}} = 0.16$$

Calculate K :
 Method 1,
 Zone 1,
 USBR

$$K = \frac{Q}{C_w r H} = \frac{\left(\frac{45 \text{ gal}}{\text{min}}\right) \left(\frac{1490 \text{ min}}{d}\right) \left(\frac{1 \text{ ft}^3}{7.48 \text{ gal}}\right)}{(120)(0.16 \text{ ft})(61.3 \text{ ft})}$$

$$K = 7.4 \text{ ft}/d$$

$$K = 2.6 \times 10^{-3} \text{ cm}/\text{sec}$$

Stoller

PACKER TEST SET-UP SHEET

JOB NO.: _____ DATE: 1-30-06
 JOB NAME: Crescent Junction Site
 PREPARED: Mark Kautsky REVIEWED: _____
 SHEET NO.: 1 OF _____
 Borehole 213
 Depth: 30-40 ft
 Pressure: 5 psi (retest)

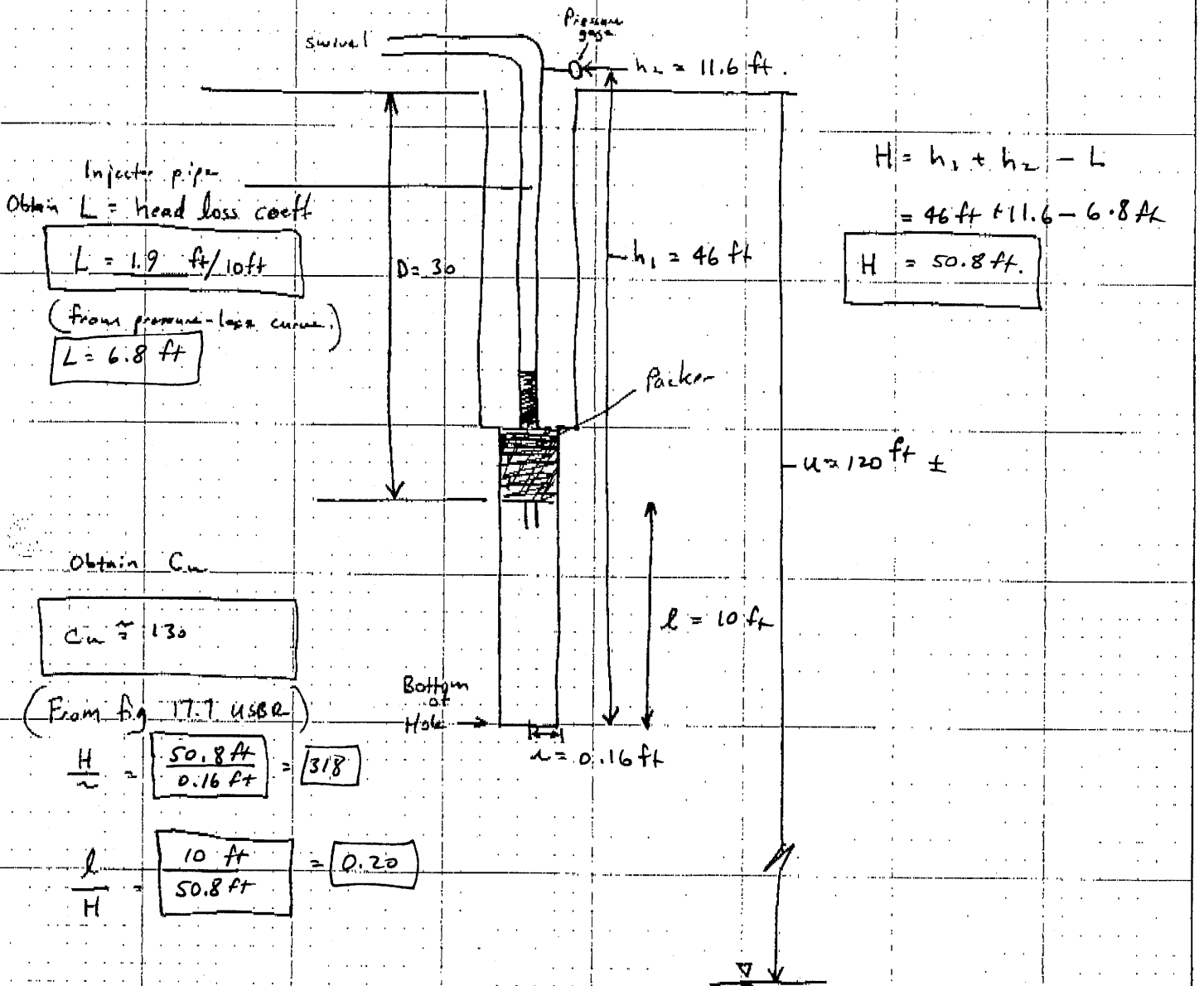

Injector pipe
 Obtain $L =$ head loss coeff
 $L = 1.9 \text{ ft}/10\text{ft}$
 (from pressure-loss curve)
 $L = 6.8 \text{ ft}$

$$H = h_1 + h_2 - L$$

$$= 46 \text{ ft} + 11.6 - 6.8 \text{ ft}$$

$$H = 50.8 \text{ ft}$$

Obtain C_u
 $C_u \approx 130$
 (From Fig. 17.7 USBR)

$$\frac{H}{r} = \frac{50.8 \text{ ft}}{0.16 \text{ ft}} = 318$$

$$\frac{l}{H} = \frac{10 \text{ ft}}{50.8 \text{ ft}} = 0.20$$

Calculate K :
 Method 1,
 Zone 1,
 USBR

$$K = \frac{Q}{C_u r H} = \frac{\left(\frac{39 \text{ gal}}{\text{min}}\right) \left(\frac{1440 \text{ min}}{\text{day}}\right) \left(\frac{1 \text{ ft}^3}{7.48 \text{ gal}}\right)}{(130) (0.16 \text{ ft}) (50.8 \text{ ft})}$$

$$K = 7.1 \text{ ft/d}$$

$$K = 2.5 \times 10^3 \text{ cm/d}$$

Stoller

established 1959

Packer-Test Record

Page 1 of 2

Project Name: Mock-Crescent Jet Characterization Date: 01/14/06

Field Representative: R. Rupp Borehole No. 0204 Total Depth: 300'

Depth to Water (TOC): 225 ft. Borehole Cleaned? Yes No Date: 01/12/06

Test Interval (BGL): from 80 to 92 ft. Swivel/Elbow Height (AGL) 4.0 ft.

Conductor Pipe, Type and Size: 1-inch ID Thin Wall STEEL TUBING

Time	Gauge Pressure	Flow Meter Reading	Flow Rate
<u>1035</u>	<u>10 psi</u>	<u>39387.75</u>	
<u>1040</u>	<u>10</u>	<u>39387.8</u>	<u>0.01 gpm</u>
<u>1045</u>	<u>10</u>	<u>39387.8</u>	<u>0</u>
<u>1050</u>	<u>10</u>	<u>39387.8</u>	<u>0</u>
<u>1055</u>	<u>10</u>	<u>39387.8</u>	<u>0</u>
<u>1100</u>	<u>20 psi</u>	<u>39388.0</u>	<u>0.04 gpm</u>
<u>1105</u>	<u>20</u>	<u>39388.15</u>	<u>0.03</u>
<u>1110</u>	<u>20</u>	<u>39388.25</u>	<u>0.02</u>
<u>1115</u>	<u>20</u>	<u>39388.4</u>	<u>0.03</u>
<u>1120</u>	<u>20</u>	<u>39388.55</u>	<u>0.03</u>
<u>1125</u>	<u>20</u>	<u>39388.7</u>	<u>0.03</u>
<u>1130</u>	<u>30 psi</u>	<u>39389.0</u>	<u>0.06</u>
<u>1135</u>	<u>30</u>	<u>39389.25</u>	<u>0.05</u>
<u>1140</u>	<u>30</u>	<u>39389.35</u>	<u>0.02</u>
<u>1145</u>	<u>30</u>	<u>39389.35</u>	<u>0</u>
<u>1150</u>	<u>30</u>	<u>39389.35</u>	<u>0</u>
<u>1155</u>	<u>30</u>	<u>39389.35</u>	<u>0</u>

A-78

Stoller

established 1959

Packer-Test Record

Page 2 of 2

Project Name: Moulton-Crocut Jct. Characterization Date: 01/14/06

Field Representative: R. Rupp Borehole No. 0204 Total Depth: 300'

Depth to Water (TOC): 225' Borehole Cleaned? Yes No Date: 01/12/06

Test Interval (BGL): from 80 to 92 ft. Swivel/Elbow Height (AGL) 4.0 ft.

Conductor Pipe, Type and Size: 1-inch ID thin wall steel tubing

Time	Gauge Pressure	Flow Meter Reading	Flow Rate
<u>1200</u>	<u>20 psi</u>	<u>39389.45</u>	<u>0.02 gpm</u>
<u>1205</u>	<u>20</u>	<u>39389.7</u>	<u>0.05</u>
<u>1210</u>	<u>20</u>	<u>39389.95</u>	<u>0.05</u>
<u>1215</u>	<u>20</u>	<u>39390.15</u>	<u>0.04</u>
<u>1220</u>	<u>20</u>	<u>39390.35</u>	<u>0.04</u>
<u>1225</u>	<u>20</u>	<u>39390.55</u>	<u>0.04</u>
<u>1230</u>	<u>10 psi</u>	<u>39390.55</u>	<u>0</u>
<u>1235</u>	<u>10</u>	<u>39390.6</u>	<u>0.01</u>
<u>1240</u>	<u>10</u>	<u>39390.65</u>	<u>0.01</u>
<u>1245</u>	<u>10</u>	<u>39390.65</u>	<u>0</u>
<u>1250</u>	<u>10</u>	<u>39390.65</u>	<u>0</u>
<u>1255</u>	<u>10</u>	<u>39390.65</u>	<u>0</u>

A-79

Stoller

DATE 1-25-06

JOB NAME Crescent Junction

PREPARED: M. Kautsky

REVIEWED:

SHEET NO. OF

PACKER TEST ANALYSES

BOREHOLE : 204

Depth : 80 - 92 ft

Pressure (h_2) : 10 psi (23.1 ft)

Unsaturated Zone Calculation:

Definitions:

 l = length of test section

$$T_u = u - D + H$$

 u = Thickness of Unsaturated Material D = distance from ground surface to bottom of test section

$$H = h_1 + h_2 - L$$

 L = head loss ; ignore if $Q < 4 \text{ gpm}$

$$X = \frac{H}{T_u} (100) ; \text{percent unsaturated material}$$

Reference Figure 17-6 U.S. Bureau of Rec. Earth Manual

$$l = 12 \text{ ft}$$

$$T_u = u - D + H = (225 \text{ ft}) - (92 \text{ ft}) + (119.1 \text{ ft}) = 252.1 \text{ ft}$$

$$\frac{T_u}{l} = \frac{252.1 \text{ ft}}{12 \text{ ft}} = \boxed{21}$$

$$H = h_1 + h_2 - L = (96 \text{ ft}) + (23.1 \text{ ft}) - \emptyset = 119.1 \text{ ft}$$

$$X = \frac{H}{T_u} (100) = \frac{119.1 \text{ ft}}{252.1 \text{ ft}} (100) = \boxed{47}$$

$$h_1 = (D) + (\text{stick up height}) = (92 \text{ ft}) + (4 \text{ ft}) = 96 \text{ ft}$$

WATER TESTING FOR PERMEABILITY

- Effective head, the difference in feet (m) between the elevation of the free water surface in the pipe and the elevation of the gauge plus the applied pressure. If a pressure transducer is used, the effective head in the test section is the difference in pressure before water is pumped into the test section and the pressure readings made during the test.

The following examples show some typical calculations using Methods 1 and 2 in the different zones shown in figure 17-5. Figure 17-6 shows the location of the zone 1 lower boundary for use in unsaturated materials.

Pressure permeability tests examples using Methods 1 and 2:

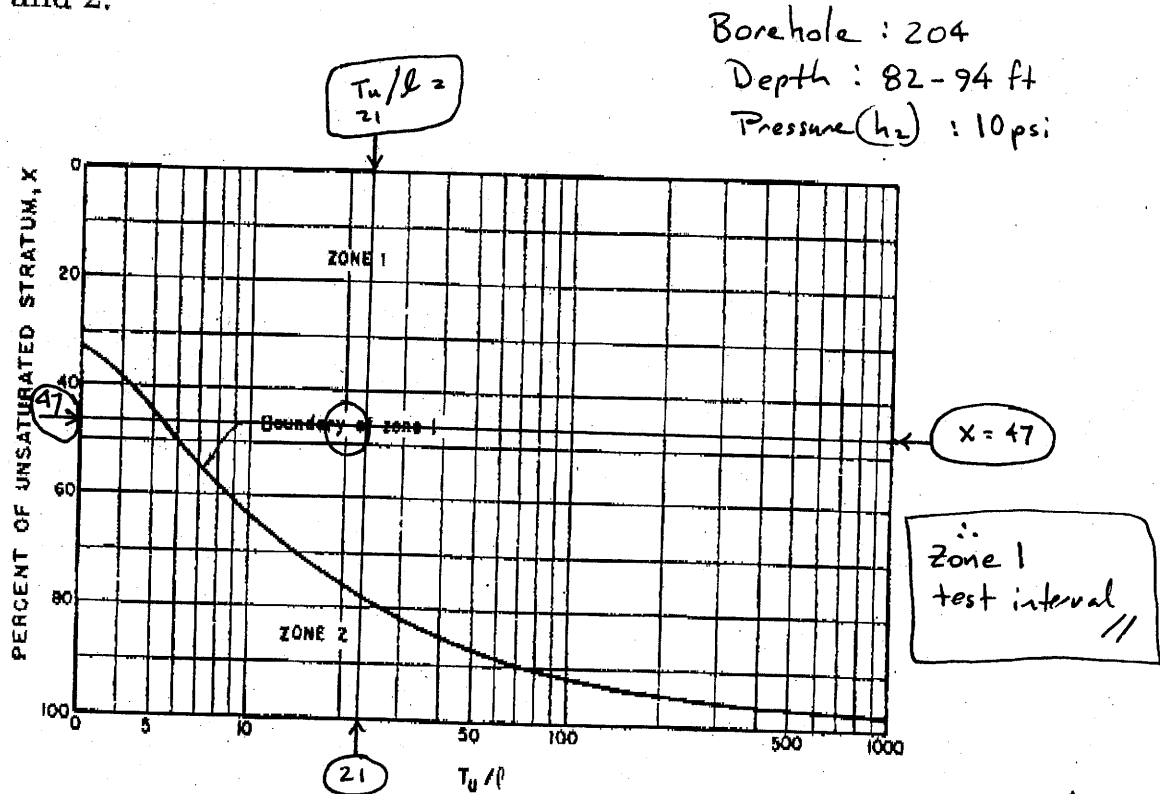

Figure 17-6.—Location of zone 1 lower boundary for use in unsaturated materials.

$$\frac{T_u}{l} = 21$$

$$X = 47$$

WATER TESTING FOR PERMEABILITY

1-25-06

Borehole : 204

Depth : 80 - 92 ft.

Pressure : 10 psi

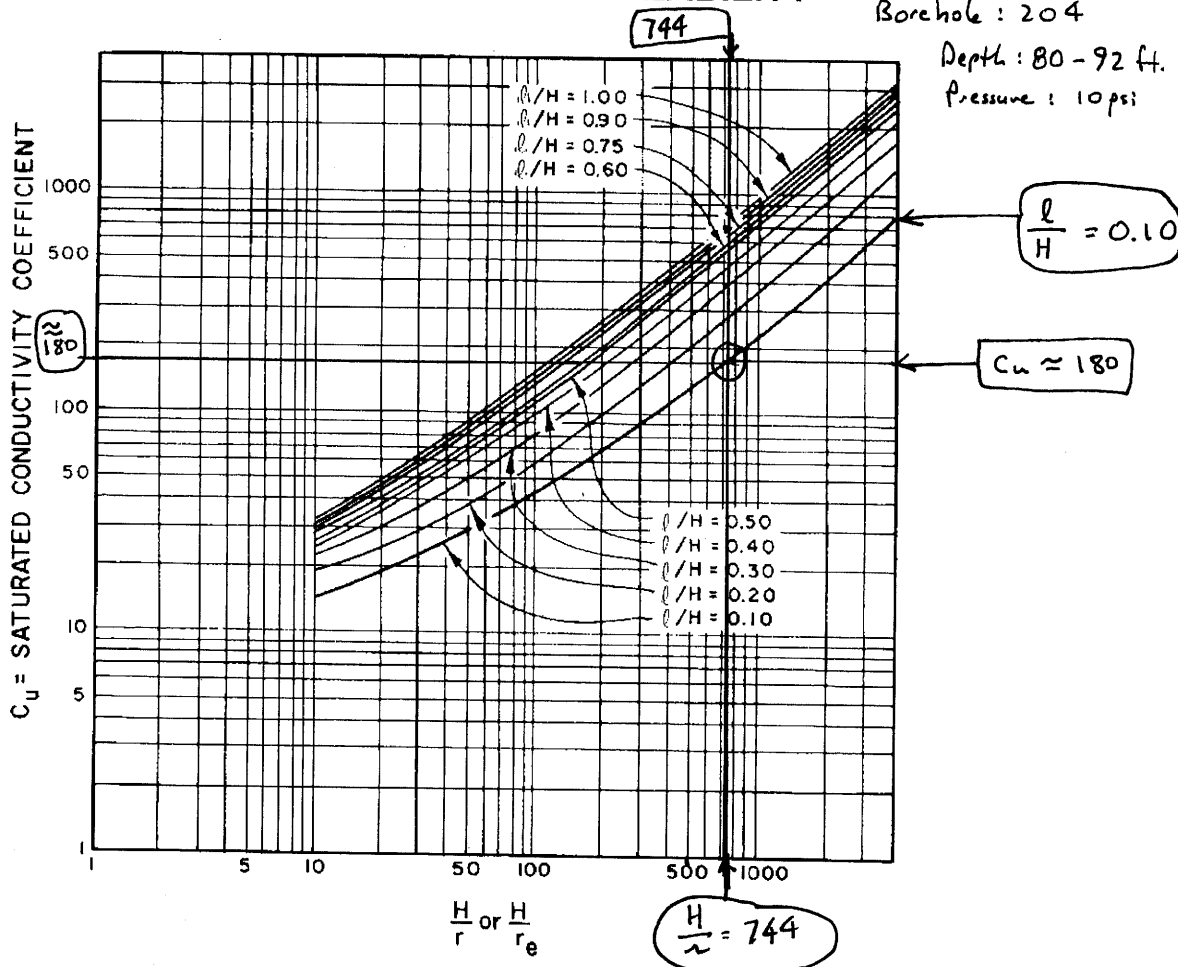

**Figure 17-7.—Conductivity coefficients
for permeability determination in
unsaturated materials with partially
penetrating cylindrical test wells.**

Zone 2

Given: U , l , r , h_2 , Q , and L are as given in example 1, $D = 65$ feet, and $h_1 = 72$ feet

If the distance from the gauge to the bottom of the intake pipe is 62 feet, the total L is $(6.2)(0.76) = 4.7$ feet.

$$H = 72 + 57.8 - 4.7 = 125.1 \text{ feet}$$

Stoller

Packer Test Set-up Sheet

For straddle packer tests in Zone 1
- Above water Table -

JOB NO. _____ DATE: 1-25-06

JOB NAME: Crescent Junction Site

PREPARED: _____

REVIEWED:
Borehole 204
Depth: 80-92ft
Pressure: 10 psi (23.1ft)

SHEET NO. _____ OF _____

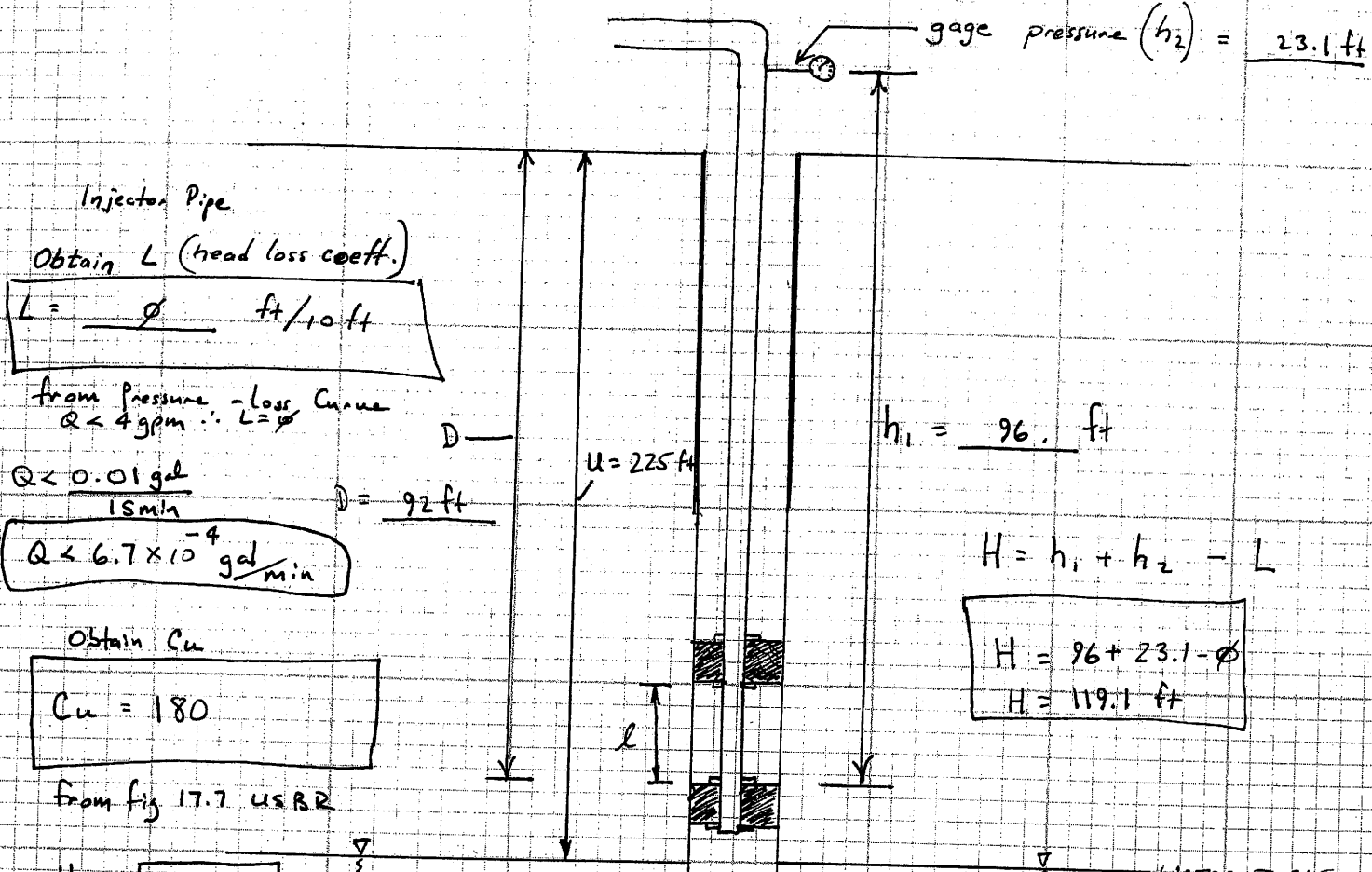

Injector Pipe
Obtain L (head loss coeff.)
 $L = \varnothing$ ft/10 ft

from Pressure - Loss Curve
 $Q < 4$ gpm $\therefore L = \varnothing$

$Q < 0.01$ gal
15 min $D = 92$ ft

$Q < 6.7 \times 10^{-4}$ gal/min

Obtain C_u
 $C_u = 180$

from fig 17.7 USBR

$$\frac{H}{u} = \frac{119.1 \text{ ft}}{225 \text{ ft}} = 0.53$$

$$\frac{l}{H} = \frac{12 \text{ ft}}{119.1 \text{ ft}} = 0.10$$

$$K < \frac{(6.7 \times 10^{-4} \text{ gal/min}) \left(\frac{1440 \text{ min}}{d}\right) \left(\frac{1 \text{ ft}^3}{7.48 \text{ gal}}\right)}{(180)(0.16 \text{ ft})(119.1 \text{ ft})}$$

$$K < 3.7 \times 10^{-5} \text{ ft/d}$$

$$K < 1.3 \times 10^{-8} \text{ ft/d}$$

gage pressure (h_2) = 23.1 ft

$h_1 = 96$ ft

$$H = h_1 + h_2 - L$$

$$H = 96 + 23.1 - \varnothing$$

$$H = 119.1 \text{ ft}$$

Calculate K : Zone 1

$$K = \frac{Q}{C_u u H}$$

$2u$
 $u = 0.16 \text{ ft}$

Stoller

DATE: 1-25-06

JOB NAME: Crescent Junction

PREPARED: M. Kautsky

REVIEWED:

SHEET NO: OF

PACKER TEST ANALYSES

BOREHOLE: 204

Depth: 80-92 ft.

Pressure (h_2): 20 psi (46.2 ft)

Unsaturated Zone Calculation:

Definitions:

 l = length of test section $T_u = U - D + H$ U = Thickness of Unsaturated Material D = distance from ground surface to bottom of test section $H = h_1 + h_2 - L$ L = head loss; ignore if $Q < 4 \text{ gpm}$ $X = \frac{H}{T_u} (100)$; percent unsaturated material

Reference Figure 17-6 U.S. Bureau of Rec. Earth Manual

$$l = 12 \text{ ft}$$

$$T_u = U - D + H = (225 \text{ ft}) - (92 \text{ ft}) + (142.2 \text{ ft}) = 275.2 \text{ ft}$$

$$\frac{T_u}{l} = \frac{275.2 \text{ ft}}{12 \text{ ft}} \approx 23$$

$$H = h_1 + h_2 - L = 96 \text{ ft} + 46.2 \text{ ft} - \cancel{\phi} = 142.2 \text{ ft}$$

$$X = \frac{H}{T_u} (100) = \frac{142.2 \text{ ft}}{275.2 \text{ ft}} (100) \approx 52$$

$$h_1 = D + \text{stickup height} = 92 \text{ ft} + 4 \text{ ft} = 96 \text{ ft}$$

WATER TESTING FOR PERMEABILITY

- Effective head, the difference in feet (m) between the elevation of the free water surface in the pipe and the elevation of the gauge plus the applied pressure. If a pressure transducer is used, the effective head in the test section is the difference in pressure before water is pumped into the test section and the pressure readings made during the test.

The following examples show some typical calculations using Methods 1 and 2 in the different zones shown in figure 17-5. Figure 17-6 shows the location of the zone 1 lower boundary for use in unsaturated materials.

Pressure permeability tests examples using Methods 1 and 2:

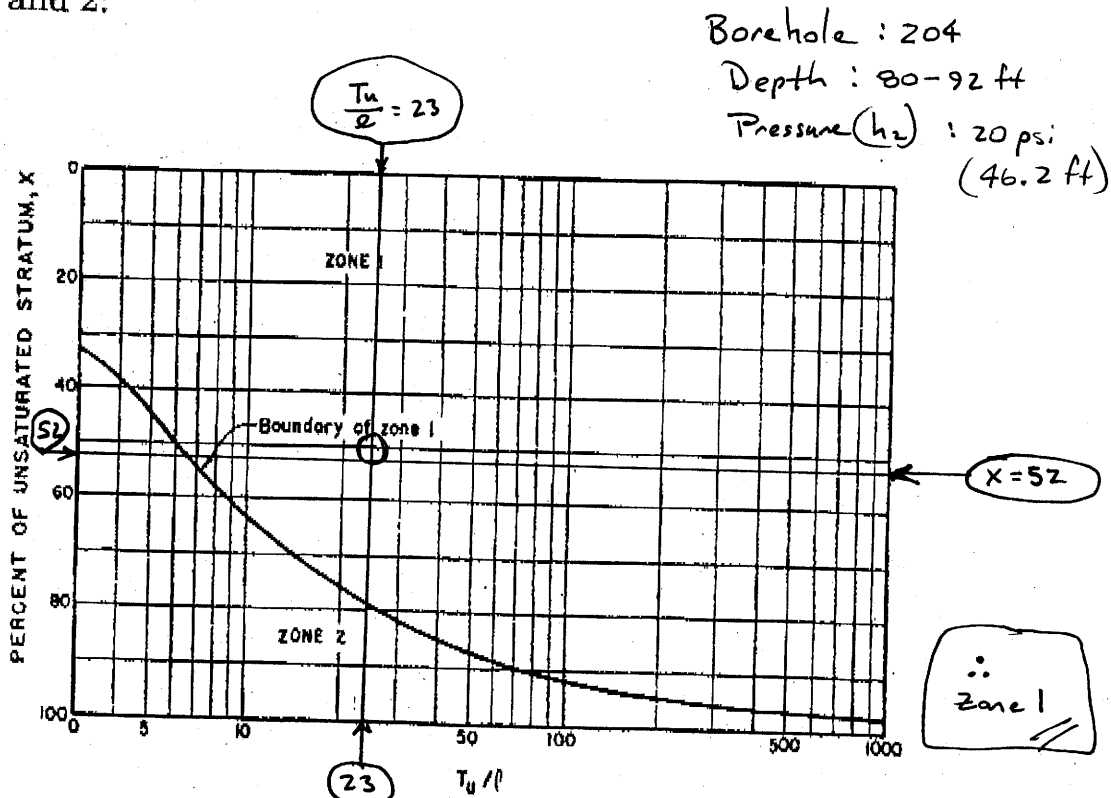

Figure 17-6.—Location of zone 1 lower boundary for use in unsaturated materials.

$$\frac{T_u}{l} = 23$$

$$X = 52$$

Borehole 204
 Depth: 80-92 ft
 Pressure: 20 psi

WATER TESTING FOR PERMEABILITY

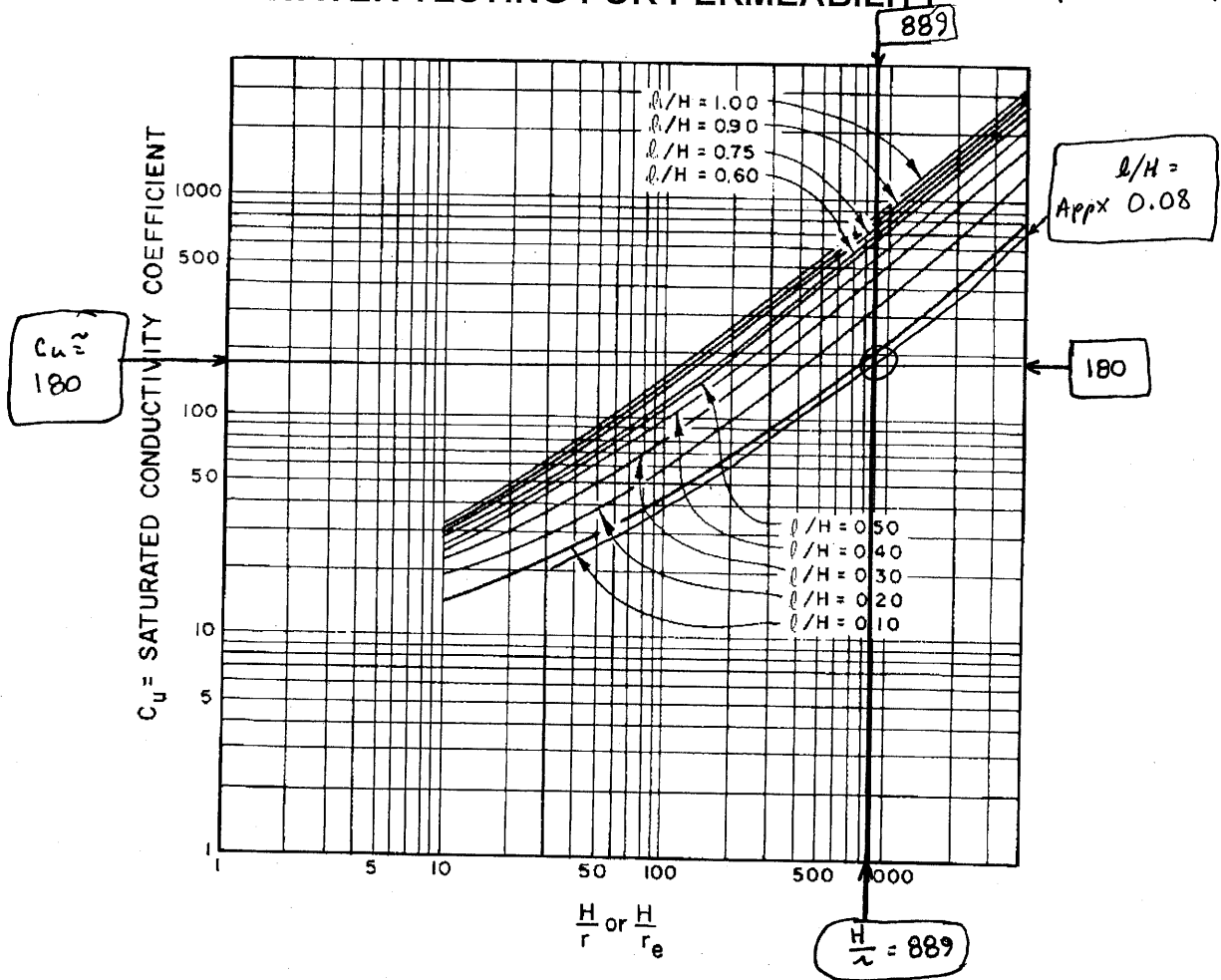

Figure 17-7.—Conductivity coefficients for permeability determination in unsaturated materials with partially penetrating cylindrical test wells.

Zone 2

Given: U , l , r , h_2 , Q , and L are as given in example 1, $D = 65$ feet, and $h_1 = 72$ feet

If the distance from the gauge to the bottom of the intake pipe is 62 feet, the total L is $(6.2)(0.76) = 4.7$ feet.

$$H = 72 + 57.8 - 4.7 = 125.1 \text{ feet}$$

S

Packer Test Set-up Sheet

For straddle packer tests in Zone I
- Above water Table -

JOB NO. _____ DATE: _____
 JOB NAME: Crescent Junction site
 PREPARED: M. Kantsky
 REVIEWED: _____
 SHEET NO. _____ OF _____
 Borehole: 204
 Depth: 80-92
 Pressure: 20 psi

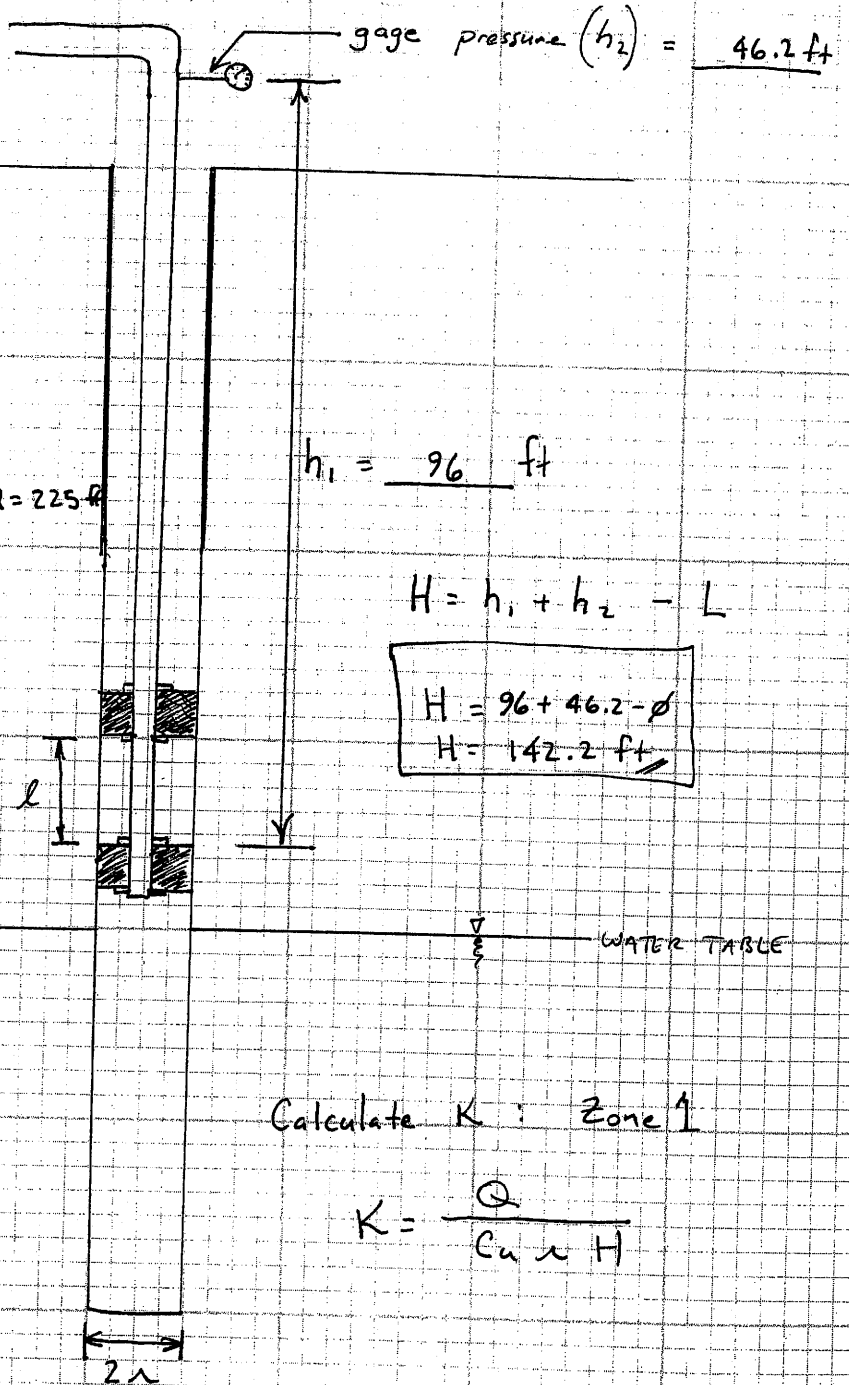

Injector Pipe

Obtain L (head loss coeff.)

$$L = \frac{\phi}{(Q < 4 \text{ gpm})} \text{ ft}/10 \text{ ft}$$

from Pressure - Loss Curve

$$Q = 0.03 \frac{\text{gal}}{\text{min}}$$

from Packer - Test Record

D =

$$D = 92 \text{ ft}$$

$$u = 225 \text{ ft}$$

$$h_1 = 96 \text{ ft}$$

$$H = h_1 + h_2 - L$$

$$H = 96 + 46.2 - \phi$$

$$H = 142.2 \text{ ft}$$

Obtain Cu

$$C_u = 180$$

from fig 17.7 USBR

$$\frac{H}{r} = \frac{142.2 \text{ ft}}{0.16 \text{ ft}} = 889$$

$$\frac{l}{H} = \frac{12 \text{ ft}}{142.2 \text{ ft}} = 0.08$$

Calculate K : Zone I

$$K = \frac{Q}{C_u r H}$$

$$K = \frac{(0.03 \frac{\text{gal}}{\text{min}}) \left(\frac{1440 \text{ min}}{d} \right) \left(\frac{\text{ft}^3}{7.48 \text{ gal}} \right)}{(180) (0.16 \text{ ft}) (142.2 \text{ ft})}$$

$$r = 0.16 \text{ ft}$$

$$K = 1.1 \times 10^{-3} \text{ ft}/d$$

$$K = 3.9 \times 10^{-7} \text{ cm}/A$$

Stoller

DATE: 1-23-06

JOB NAME: Crescent Junction

PREPARED: M. Kautsky

REVIEWED:

SHEET NO. OF

PACKER TEST ANALYSES

BOREHOLE: 204

Depth: 80-92

Pressure (h_2): 30psi (69.3 ft)

Unsaturated Zone Calculation:

Definitions:

 l = length of test section

$$T_u = U - D + H$$

 U = Thickness of Unsaturated Material D = distance from ground surface to bottom of test section

$$H = h_1 + h_2 - L$$

 L = head loss; ignore if $Q < 4$ gpm

$$X = \frac{H}{T_u} (100); \text{ percent unsaturated material}$$

Reference Figure 17-6 U.S. Bureau of Rec. Earth Manual

$$l = 12 \text{ ft}$$

$$T_u = U - D + H = 225 \text{ ft} - 92 \text{ ft} + 165.3 \text{ ft} = 298.3 \text{ ft}$$

$$\frac{T_u}{l} = \frac{298.3 \text{ ft}}{12 \text{ ft}} = \boxed{24.9}$$

$$H = h_1 + h_2 - L = 96 \text{ ft} + 69.3 \text{ ft} = 165.3 \text{ ft}$$

$$X = \frac{H}{T_u} (100) = \frac{165.3 \text{ ft}}{298.3 \text{ ft}} (100) = \boxed{55}$$

$$h_1 = D + \text{stick-up height} = 92 \text{ ft} + 4 \text{ ft} = 96 \text{ ft}$$

WATER TESTING FOR PERMEABILITY

- Effective head, the difference in feet (m) between the elevation of the free water surface in the pipe and the elevation of the gauge plus the applied pressure. If a pressure transducer is used, the effective head in the test section is the difference in pressure before water is pumped into the test section and the pressure readings made during the test.

The following examples show some typical calculations using Methods 1 and 2 in the different zones shown in figure 17-5. Figure 17-6 shows the location of the zone 1 lower boundary for use in unsaturated materials.

Pressure permeability tests examples using Methods 1 and 2:

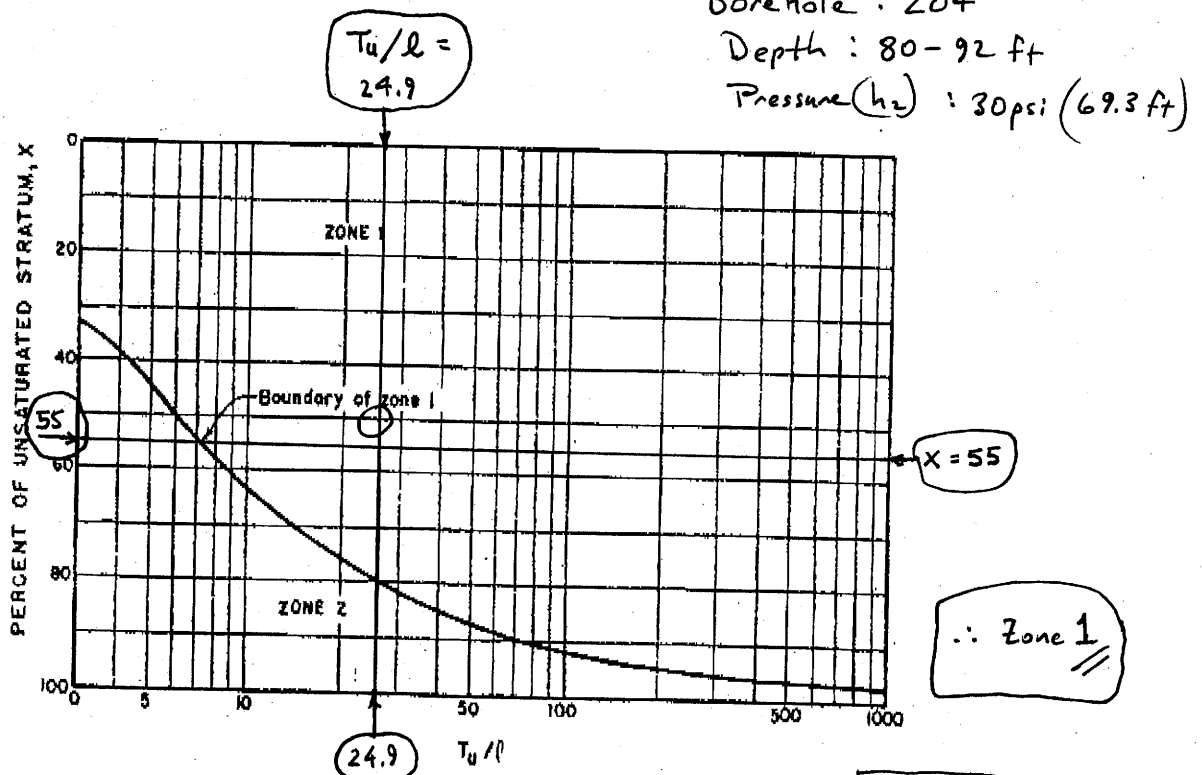

Figure 17-6.—Location of zone 1 lower boundary for use in unsaturated materials.

$$\frac{T_u}{l} = 24.9$$

$$X = 55$$

WATER TESTING FOR PERMEABILITY

Borehole : 204
 Depth : 80-92 ft
 Pressure : 30 psi
 1-23-06

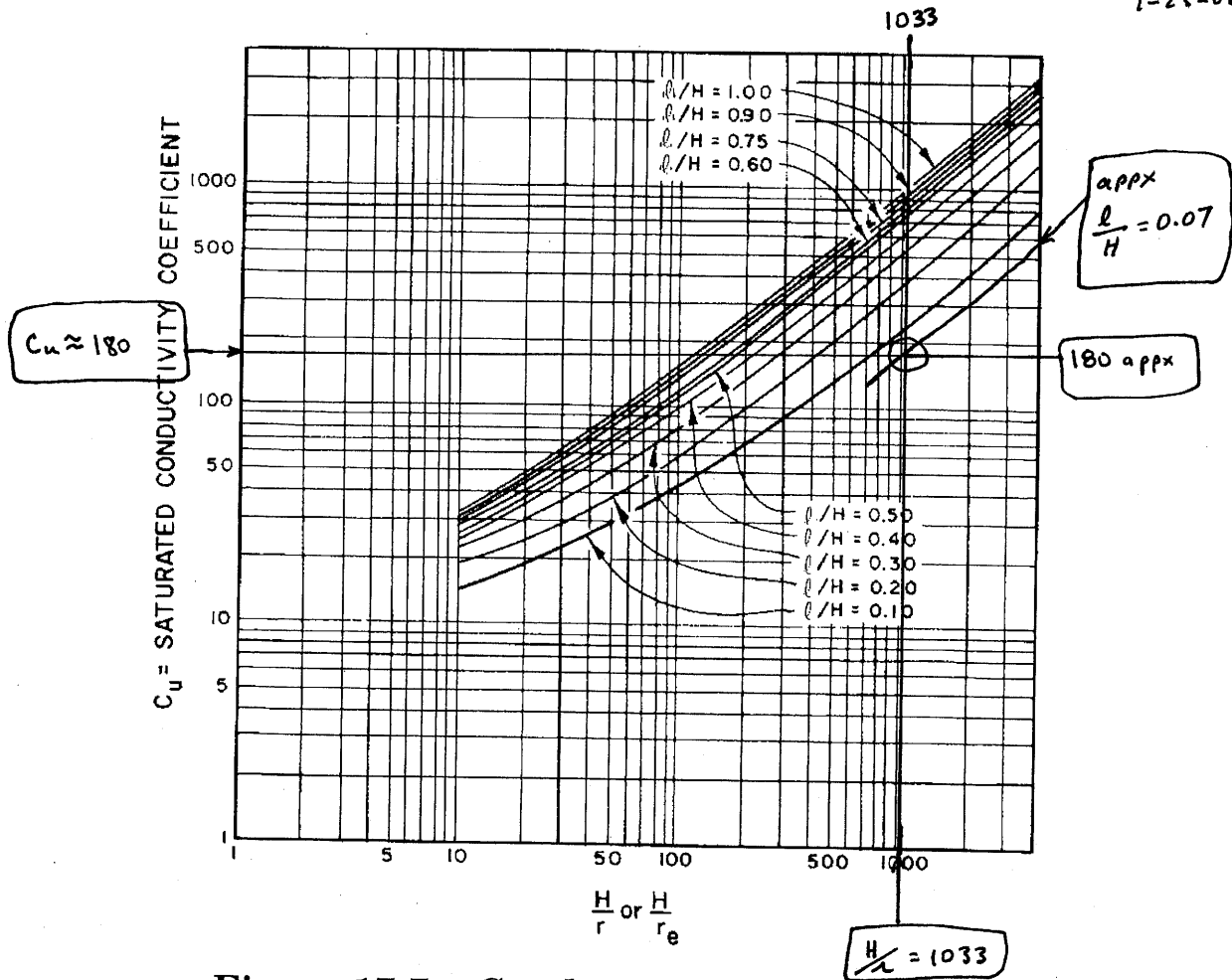

Figure 17-7.—Conductivity coefficients for permeability determination in unsaturated materials with partially penetrating cylindrical test wells.

Zone 2

Given: U , l , r , h_2 , Q , and L are as given in example 1, $D = 65$ feet, and $h_1 = 72$ feet

If the distance from the gauge to the bottom of the intake pipe is 62 feet, the total L is $(6.2)(0.76) = 4.7$ feet.

$$H = 72 + 57.8 - 4.7 = 125.1 \text{ feet}$$

Stoller

Packer Test Set-up Sheet

For straddle packer tests in Zone 1
- Above water Table -

JOB NO. _____ DATE: 1-23-06

JOB NAME: Crescent Junction site

PREPARED: M. Kautsky

REVIEWED:

Borchola: 204

Depth: 80-92

Pressure: 30 psi

SHEET NO. _____ OF _____

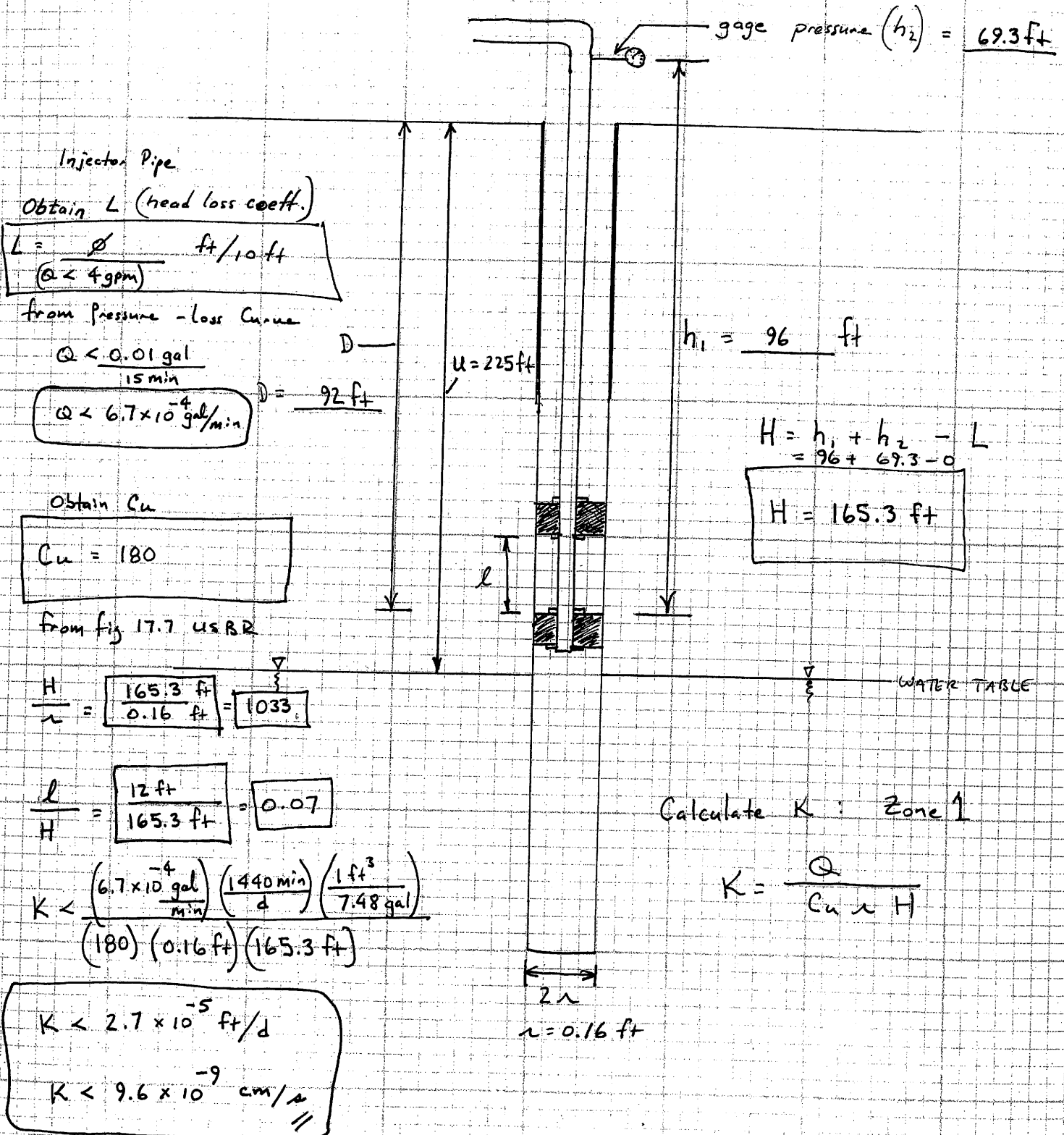

Stallor

Packer Test Set-up Sheet

For straddle packer tests in Zone I
- Above water table -

JOB NO. _____ DATE: 1-25-06

JOB NAME: Crescent Junction Site

PREPARED: Mark Kantaky

REVIEWED: _____

SHEET NO. _____

OF _____

Borehole 204
Depth: 80-92 ft

Pressure: 20 psi (retest)

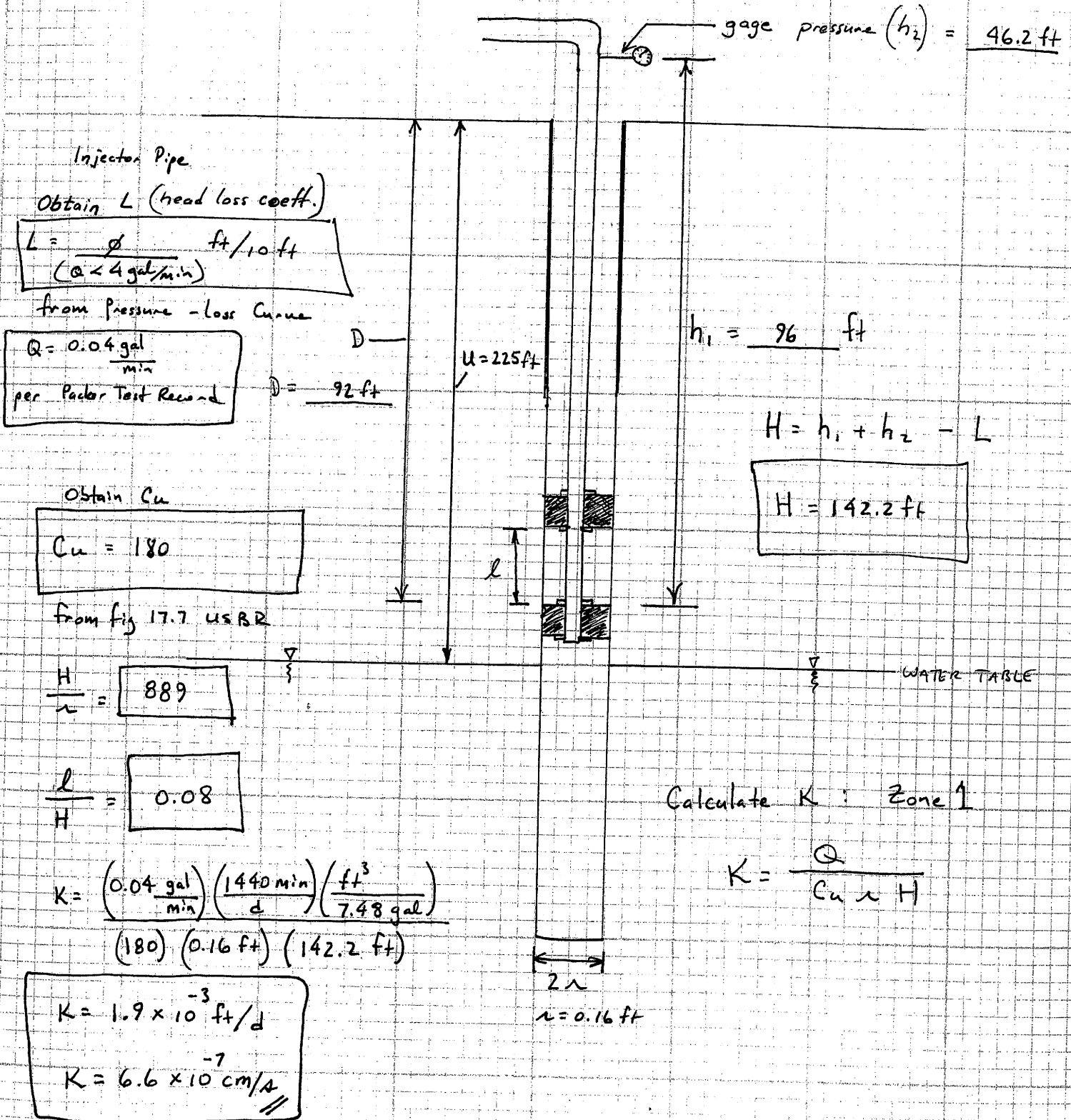

Stoller

Packer Test Set-up Sheet

For straddle packer tests in Zone 1
- Above water Table -

JOB NO.: DATE: 1-25-06

JOB NAME: Crescent Junction site

PREPARED: M. Kautsky

REVIEWED:

Borehole: 204

Depth: 80-92 ft

pressure: 10 psi (retent)

SHEET NO. OF

gage pressure (h_2) = 23.1 ft

Injector Pipe

Obtain L (head loss coeff.)

$$L = \frac{\phi}{Q} \text{ ft}/10 \text{ ft}$$

($Q < 4 \text{ gal/min}$)

from pressure-loss Curve

$$Q < \frac{0.01 \text{ gal}}{15 \text{ min}}$$

$D =$

$$U = 225 \text{ ft}$$

$$h_1 = 96 \text{ ft}$$

$$D = 92 \text{ ft}$$

$$Q < 6.7 \times 10^{-4} \frac{\text{gal}}{\text{min}}$$

per Packer Test Record

Obtain C_u

$$C_u = 180$$

from fig 17.7 USBR

$$\frac{H}{r} = \frac{119.1 \text{ ft}}{0.16 \text{ ft}} = 744$$

$$\frac{d}{H} = 0.10$$

$$K < \frac{(6.7 \times 10^{-4} \text{ gal/min}) \left(\frac{1440 \text{ min}}{d} \right) \left(\frac{1 \text{ ft}^3}{7.48 \text{ gal}} \right)}{(180) (0.16 \text{ ft}) (119.1 \text{ ft})}$$

$$K < 3.7 \times 10^{-5} \text{ ft/d}$$

$$K < 1.3 \times 10^{-8} \text{ cm/s}$$

$$H = h_1 + h_2 - L$$

$$H = 119.1 \text{ ft}$$

Calculate K : Zone 1

$$K = \frac{Q}{C_u r H}$$

Stoller

established 1959

Packer-Test Record

Page 1 of 2

Project Name: Moab-Crescent Jet Characterization Date: 01/13/06- 01/14/06

Field Representative: R. Rupp Borehole No. 0204 Total Depth: 300 ft.

Depth to Water (TOC): 225 ft Borehole Cleaned? Yes No Date: 01/12/06

Test Interval (BGL): from 110 to 122 ft. Swivel/Elbow Height (AGL) 4.0 ft.

Conductor Pipe, Type and Size: 1-inch ID thin wall steel tubing

Time	Gauge Pressure	Flow Meter Reading	Flow Rate
<u>1610</u>	<u>10 psi</u>	<u>39377.1</u>	
<u>1615</u>	<u>10</u>	<u>39377.2</u>	<u>0.02 gpm</u>
<u>1620</u>	<u>10</u>	<u>39377.35</u>	<u>0.03</u>
<u>1625</u>	<u>10</u>	<u>39377.35</u>	<u>0</u>
<u>1630</u>	<u>10</u>	<u>39377.35</u>	<u>0</u>
<u>1635</u>	<u>10</u>	<u>39377.35</u>	<u>0</u>
<u>1640</u>	<u>10</u>	<u>39377.35</u>	<u>0</u>
<u>1641</u>	<u>20 psi</u>	<u>39378.05</u>	
<u>1645</u>	<u>20</u>	<u>39378.4</u>	<u>0.09 gpm</u>
<u>1650</u>	<u>20</u>	<u>39378.55</u>	<u>0.03</u>
<u>1655</u>	<u>20</u>	<u>39378.85</u>	<u>0.06</u>
<u>1700</u>	<u>20</u>	<u>39378.05 pm</u>	<u>0.04</u>
<u>1705</u>	<u>20</u>	<u>39379.25</u>	<u>0.04</u>
<u>1710</u>	<u>20</u>	<u>39379.3</u>	<u>0.01</u>
<u>1715</u>	<u>20</u>	<u>39379.35</u>	<u>0.01</u>
<u>1720</u>	<u>20</u>	<u>39379.4</u>	<u>0.01</u>
<u>0800</u>	<u>30 psi</u>	<u>39379.05</u>	
<u>0805</u>	<u>30</u>	<u>39379.15</u>	<u>0.02 gpm</u>

A-94

Stoller

established 1959

Packer-Test Record

Page 2 of 2

Project Name: Moab - Crescent Jct Characterization Date: 01/14/06

Field Representative: R. Rupp Borehole No. 0204 Total Depth: 300 ft

Depth to Water (TOC): 225 ft Borehole Cleaned? Yes No Date: 01/12/06

Test Interval (BGL): from 110 to 122 ft. Swivel/Elbow Height (AGL) 4.0 ft

Conductor Pipe, Type and Size: 1-inch ID thin wall tubing

Time	Gauge Pressure	Flow Meter Reading	Flow Rate
<u>0810</u>	<u>30 psi</u>	<u>39379.5</u>	<u>0.07 gpm</u>
<u>0815</u>	<u>30</u>	<u>39379.8</u>	<u>0.06</u>
<u>0820</u>	<u>30</u>	<u>39380.1</u>	<u>0.06</u>
<u>0825</u>	<u>30</u>	<u>39380.3</u>	<u>0.04</u>
<u>0830</u>	<u>30</u>	<u>39380.5</u>	<u>0.04</u>
<u>0835</u>	<u>30</u>	<u>39380.7</u>	<u>0.04</u>
<u>0840</u>	<u>20 psi</u>	<u>39380.4</u>	<u>-0.06</u>
<u>0845</u>	<u>20</u>	<u>39380.3</u>	<u>0 -0.02</u>
<u>0850</u>	<u>20</u>	<u>39380.3</u>	<u>0</u>
<u>0855</u>	<u>20</u>	<u>39380.3</u>	<u>0</u>
<u>0900</u>	<u>10 psi</u>	<u>39379.75</u>	<u>-0.11</u>
<u>0905</u>	<u>10</u>	<u>39378.75</u>	<u>-0.20</u>
<u>0910</u>	<u>10</u>	<u>39378.85</u>	<u>0.02</u>
<u>0915</u>	<u>10</u>	<u>39378.5</u>	<u>-0.07</u>
<u>0920</u>	<u>10</u>	<u>39378.4</u>	<u>-0.02</u>
<u>0925</u>	<u>10</u>	<u>39378.15</u>	<u>-0.05</u>
<u>0930</u>	<u>10</u>	<u>39378.0</u>	<u>-0.03</u>
<u>0935</u>	<u>10</u>	<u>39377.95</u>	<u>-0.01</u>
<u>0940</u>	<u>10</u>	<u>39377.85</u>	<u>-0.02</u>
<u>0945</u>	<u>10</u>	<u>39377.85</u>	<u>0</u>
<u>0950</u>	<u>10</u>	<u>39377.85</u>	<u>0</u>

A-95

Stoller

DATE: 1-26-06

JOB NAME: Crescent Junction

PREPARED: M. Kautsky

REVIEWED:

SHEET NO.: OF

PACKER TEST ANALYSES

BOREHOLE: 204

Depth: 110-122 ft

Pressure (h_2): 10 psi (23.1 ft)

Unsaturated Zone Calculation:

Definitions:

 L = length of test section $T_u = u - D + H$ u = Thickness of Unsaturated Material D = distance from ground surface to bottom of test section $H = h_1 + h_2 - L$ L = head loss; ignore if $Q < 4$ gpm $X = \frac{H}{T_u} (100)$; percent unsaturated material

Reference Figure 17-6 U.S. Bureau of Rec. Earth Manual

$$L = 12 \text{ ft}$$

$$T_u = u - D + H = (225 \text{ ft}) - (122 \text{ ft}) + (149.1 \text{ ft}) = 252.1 \text{ ft}$$

$$\frac{T_u}{L} = \frac{252.1 \text{ ft}}{12 \text{ ft}} = \boxed{21}$$

$$H = h_1 + h_2 - L = 126 \text{ ft} + 23.1 \text{ ft} - 0 = 149.1 \text{ ft}$$

$$X = \frac{H}{T_u} (100) = \frac{149.1 \text{ ft}}{252.1 \text{ ft}} (100) = \boxed{59}$$

$$h_1 = 122 \text{ ft} + 4 \text{ ft} = 126 \text{ ft}$$

WATER TESTING FOR PERMEABILITY

1-26-06

- Effective head, the difference in feet (m) between the elevation of the free water surface in the pipe and the elevation of the gauge plus the applied pressure. If a pressure transducer is used, the effective head in the test section is the difference in pressure before water is pumped into the test section and the pressure readings made during the test.

The following examples show some typical calculations using Methods 1 and 2 in the different zones shown in figure 17-5. Figure 17-6 shows the location of the zone 1 lower boundary for use in unsaturated materials.

Pressure permeability tests examples using Methods 1 and 2:

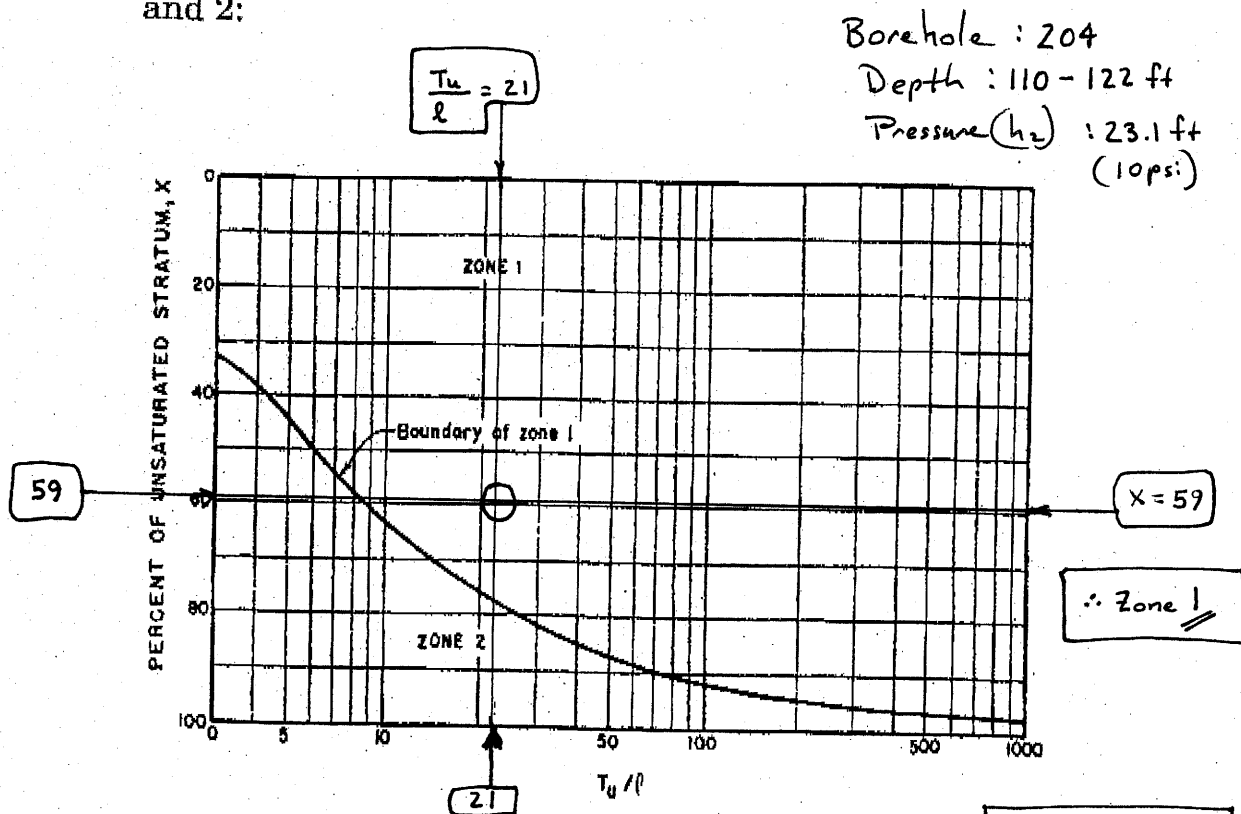

Figure 17-6.—Location of zone 1 lower boundary for use in unsaturated materials.

$$\frac{T_u}{l} = 21$$

$$X = 59$$

WATER TESTING FOR PERMEABILITY

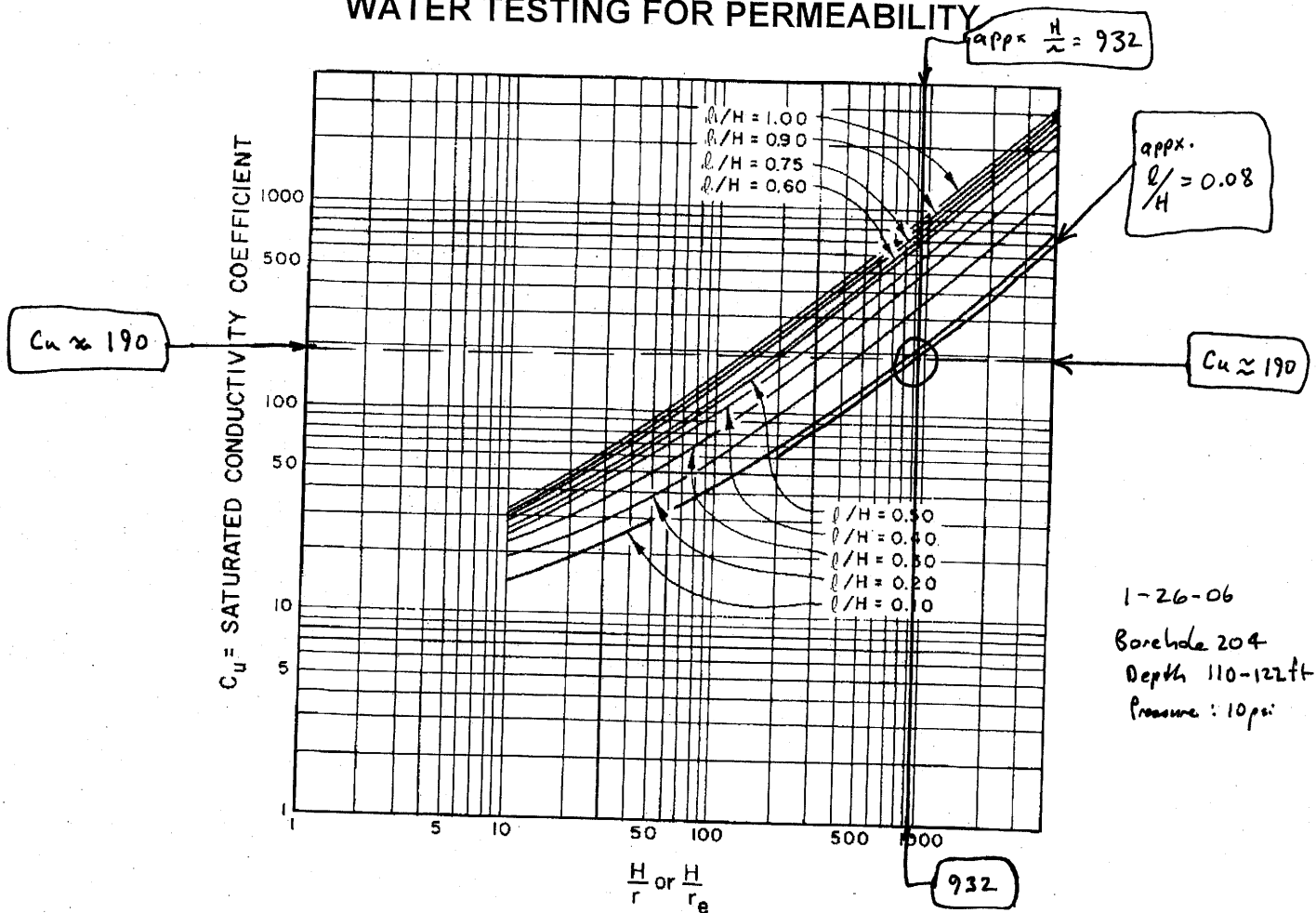

Figure 17-7.—Conductivity coefficients for permeability determination in unsaturated materials with partially penetrating cylindrical test wells.

Zone 2

Given: U , l , r , h_2 , Q , and L are as given in example 1, $D = 65$ feet, and $h_1 = 72$ feet

If the distance from the gauge to the bottom of the intake pipe is 62 feet, the total L is $(6.2)(0.76) = 4.7$ feet.

$$H = 72 + 57.8 - 4.7 = 125.1 \text{ feet}$$

Straddle Packer Test Set-up Sheet

For straddle packer tests in Zone I
- Above water Table -

JOB NO.: _____ DATE: 1-26-06
 JOB NAME: Crescent Junction site
 PREPARED: M. Kantsky
 SHEET NO.: _____ OF _____
 REVIEWED: Borehole 204
 Depth: 110-122 ft.
 Pressure: 10 psi

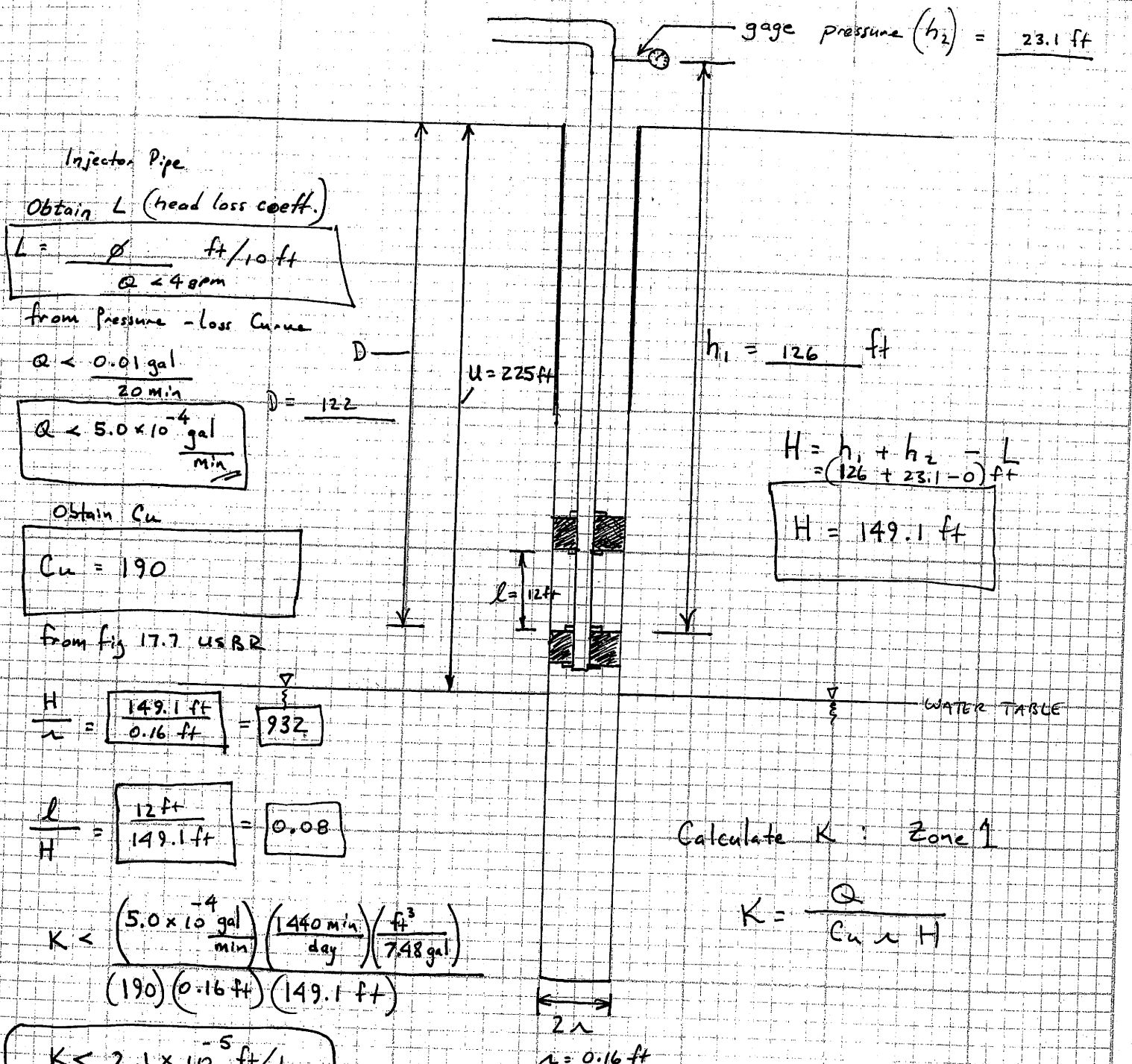

Injector Pipe
 Obtain L (head loss coeff.)
 $L = \frac{D}{Q} \text{ ft}/10 \text{ ft}$
 $Q < 2.48 \text{ cm}$

from Pressure - Loss Curve
 $Q < 0.01 \text{ gal}/20 \text{ min}$
 $D = 122$
 $Q < 5.0 \times 10^{-4} \text{ gal}/\text{min}$

Obtain C_u
 $C_u = 190$

from fig 17.7 USBR

$$\frac{H}{r} = \frac{149.1 \text{ ft}}{0.16 \text{ ft}} = 932$$

$$\frac{l}{H} = \frac{12 \text{ ft}}{149.1 \text{ ft}} = 0.08$$

$$K < \frac{(5.0 \times 10^{-4} \text{ gal}/\text{min}) (1440 \text{ min}/\text{day}) (ft^3 / 7.48 \text{ gal})}{(190) (0.16 \text{ ft}) (149.1 \text{ ft})}$$

$K < 2.1 \times 10^{-5} \text{ ft}/\text{day}$
 $K < 7.5 \times 10^{-9} \text{ cm}/\text{sec}$

gage pressure (h_2) = 23.1 ft

$h_1 = 126 \text{ ft}$

$$H = h_1 + h_2 - L = (126 + 23.1 - 0) \text{ ft}$$

$H = 149.1 \text{ ft}$

Calculate K : Zone 1

$$K = \frac{Q}{C_u r H}$$

Stoller

DATE: 1-26-06

JOB NAME: Crescent Junction

PREPARED: M. Kautsky

REVIEWED:

SHEET NO. OF

PACKER TEST ANALYSES

Unsaturated Zone Calculation:

BOREHOLE: 204

Depth: 110 - 122 ft

Pressure (h_2): 20 psi (46.2 ft)

Definitions:

 l = length of test section $T_u = u - D + H$ u = Thickness of Unsaturated Material D = distance from ground surface to bottom of test section $H = h_1 + h_2 - L$ L = head loss; ignore if $Q < 4$ gpm $X = \frac{H}{T_u} (100)$; percent unsaturated material

Reference Figure 17-6 U.S. Bureau of Rec. Earth Manual

$$l = 12 \text{ ft}$$

$$T_u = u - D + H = (225 \text{ ft}) - (122 \text{ ft}) + (172.2 \text{ ft}) = 275.2 \text{ ft}$$

$$\frac{T_u}{l} = \frac{275.2 \text{ ft}}{12 \text{ ft}} = \boxed{23}$$

$$H = h_1 + h_2 - L = (126 \text{ ft}) + (46.2 \text{ ft}) - 0 = 172.2 \text{ ft}$$

$$X = \frac{H}{T_u} (100) = \frac{172.2 \text{ ft}}{275.2 \text{ ft}} (100) = \boxed{63}$$

$$h_1 = 122 \text{ ft} + 4 \text{ ft} = 126 \text{ ft}$$

WATER TESTING FOR PERMEABILITY

- Effective head, the difference in feet (m) between the elevation of the free water surface in the pipe and the elevation of the gauge plus the applied pressure. If a pressure transducer is used, the effective head in the test section is the difference in pressure before water is pumped into the test section and the pressure readings made during the test.

The following examples show some typical calculations using Methods 1 and 2 in the different zones shown in figure 17-5. Figure 17-6 shows the location of the zone 1 lower boundary for use in unsaturated materials.

Pressure permeability tests examples using Methods 1 and 2: 1-26-06

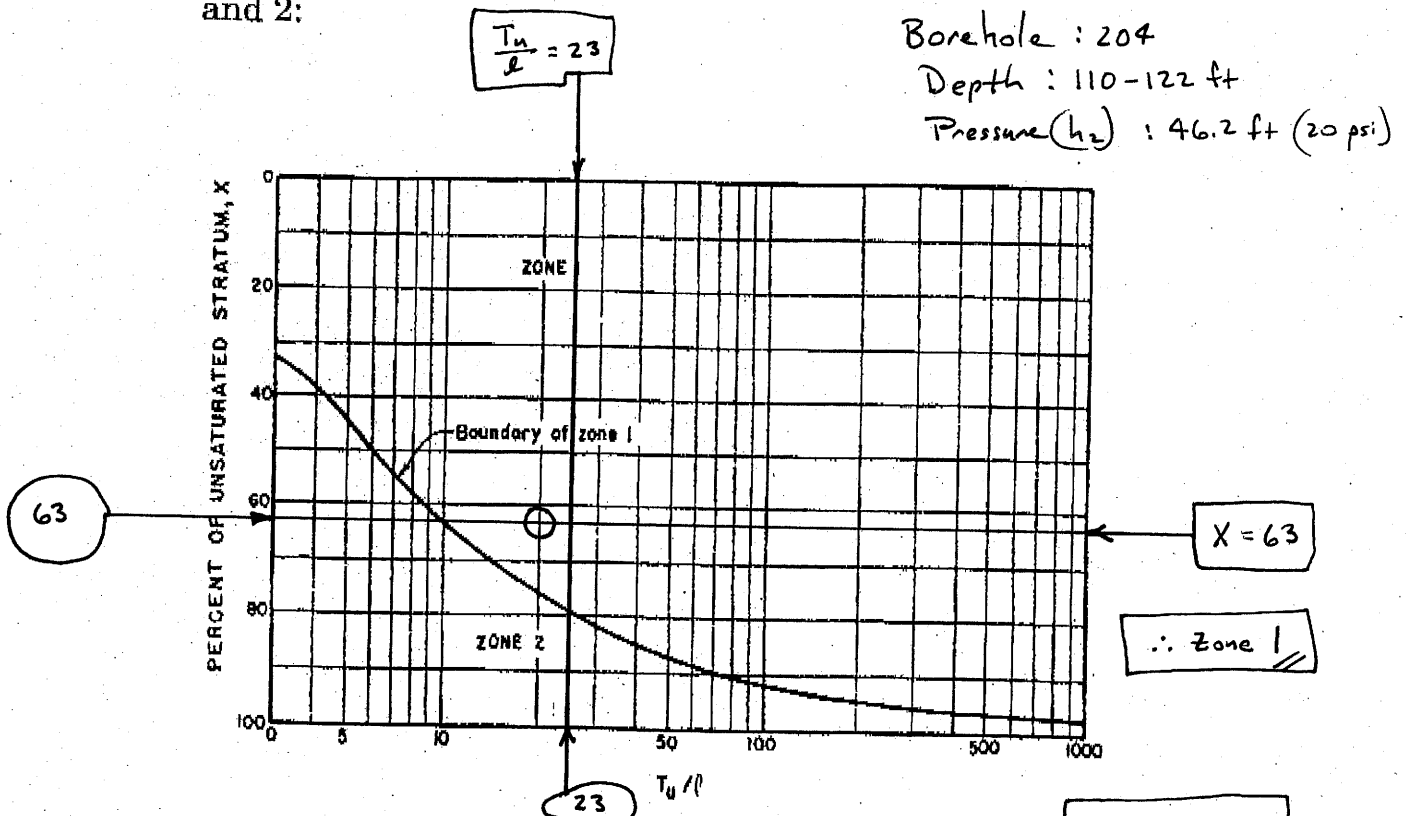

Figure 17-6.—Location of zone 1 lower boundary for use in unsaturated materials.

$$\frac{T_u}{l} = 23$$

$$X = 63$$

1-26-06
 Barhole 204
 Depth 110-122
 pressure: 20 psi

WATER TESTING FOR PERMEABILITY

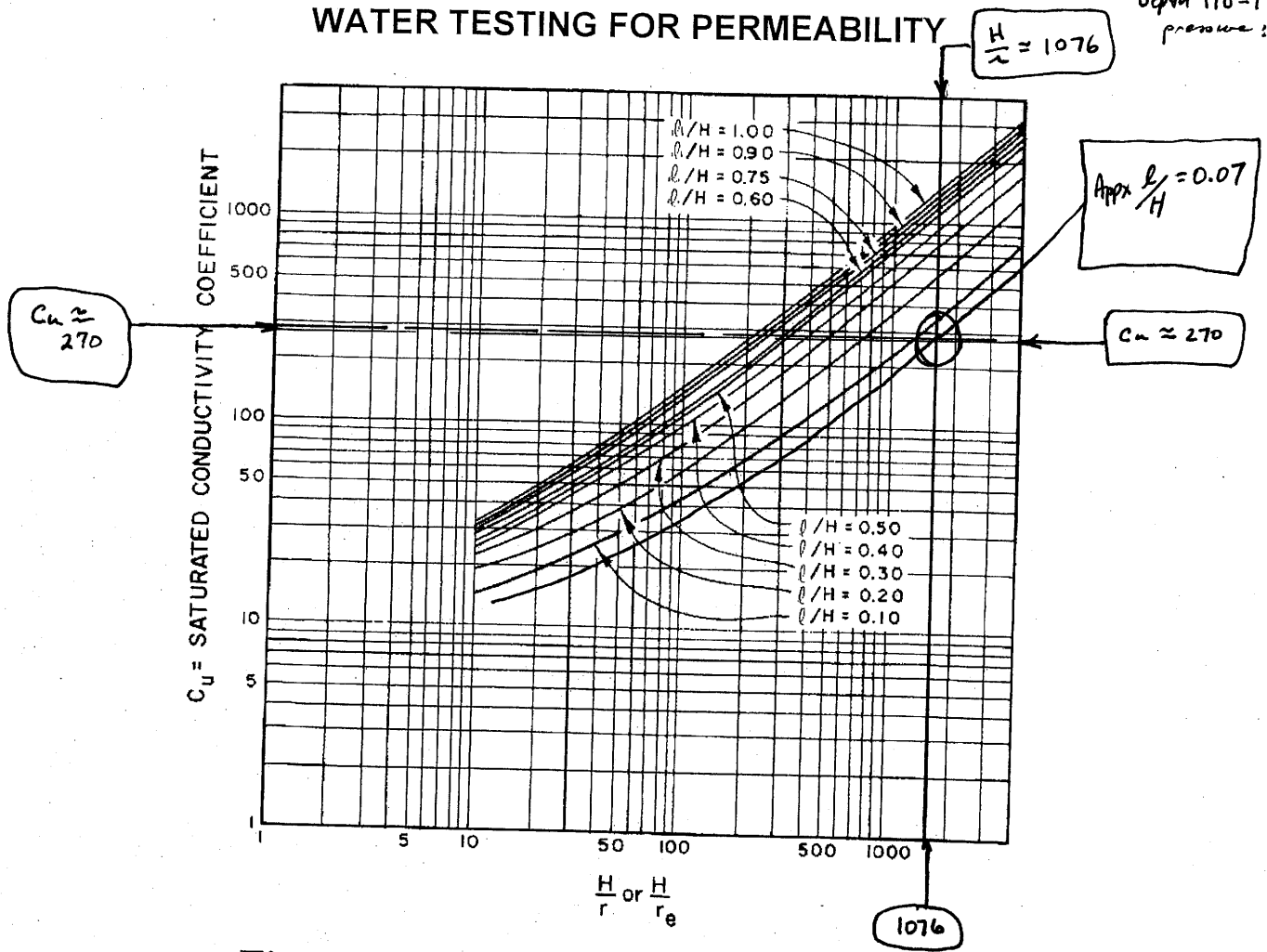

Figure 17-7.—Conductivity coefficients for permeability determination in unsaturated materials with partially penetrating cylindrical test wells.

Zone 2

Given: U , l , r , h_2 , Q , and L are as given in example 1, $D = 65$ feet, and $h_1 = 72$ feet.

If the distance from the gauge to the bottom of the intake pipe is 62 feet, the total L is $(6.2)(0.76) = 4.7$ feet.

$$H = 72 + 57.8 - 4.7 = 125.1 \text{ feet}$$

S

Packer Test Set-up Sheet

For straddle packer tests in Zone 1
- Above water Table -

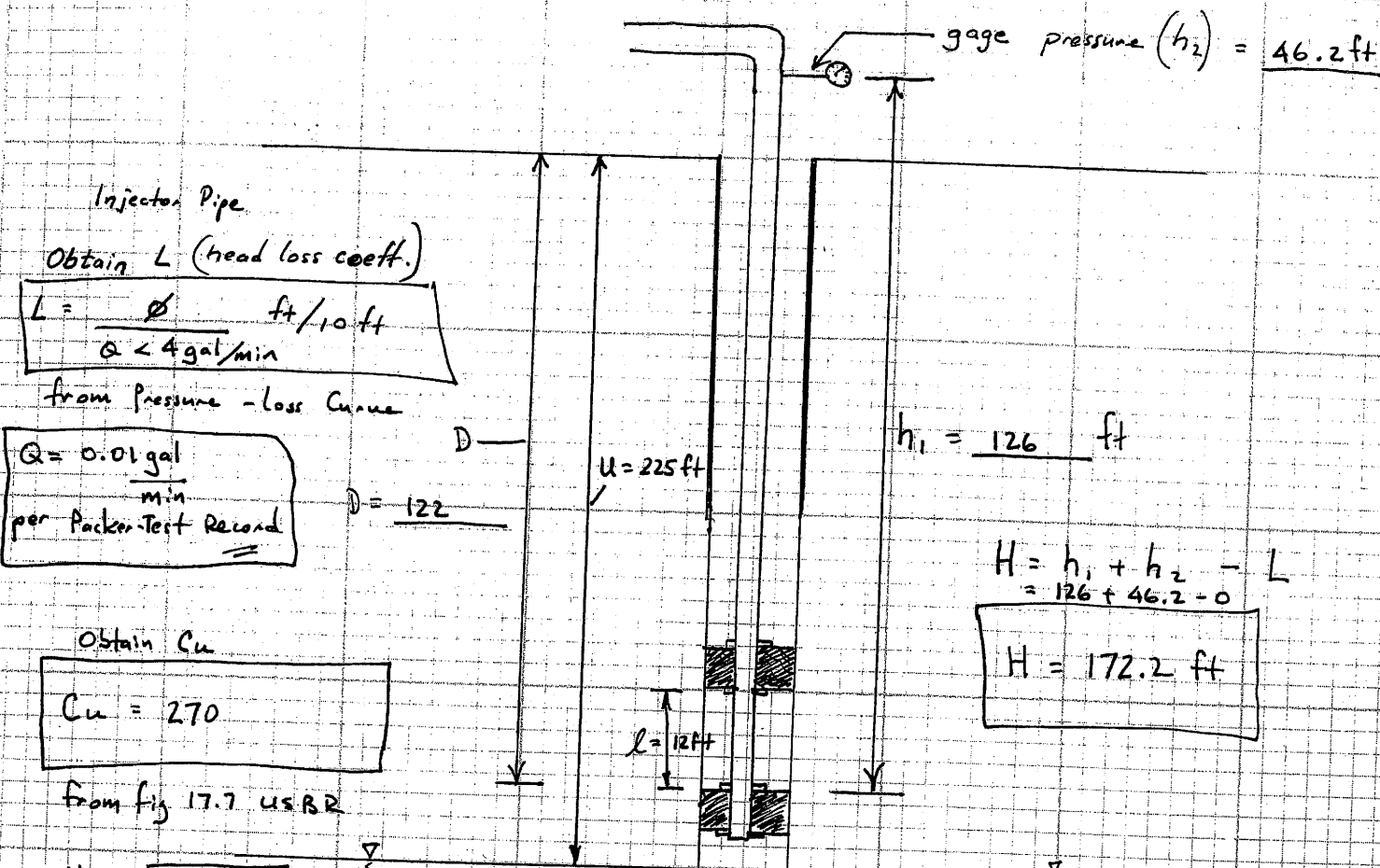

Injector Pipe
Obtain L (head loss coeff.)
 $L = \frac{\phi}{Q < 4 \text{ gal/min}}$ ft/10 ft
from Pressure - Loss Curve

$Q = 0.01 \frac{\text{gal}}{\text{min}}$
per Packer Test Record

$D = 122$

Obtain C_u
 $C_u = 270$

from fig 17.7 USBR

$\frac{H}{r} = \frac{172.2 \text{ ft}}{0.16 \text{ ft}} = 1076$

$\frac{l}{H} = \frac{12 \text{ ft}}{172.2 \text{ ft}} = 0.07$

$H = h_1 + h_2 - L$
 $= 126 + 46.2 - 0$
 $H = 172.2 \text{ ft}$

$K = \frac{(0.01 \text{ gal/min}) \left(\frac{1440 \text{ min}}{\text{day}} \right) \left(\frac{\text{ft}^3}{7.48 \text{ gal}} \right)}{(270)(0.16 \text{ ft})(172.2 \text{ ft})}$

Calculate K: Zone 1

$K = \frac{Q}{C_u r H}$

$K = 2.6 \times 10^{-4} \text{ ft/d}$
 $K = 9.1 \times 10^{-8} \text{ cm/sec}$

$2r$
 $r = 0.16 \text{ ft}$

Stoller

DATE

1-26-06

JOB NAME: Crescent Junction

PREPARED: M. Kautsky

REVIEWED:

SHEET NO. OF

PACKER TEST ANALYSES

BOREHOLE : 204

Depth : 110-122 ft

Pressure (h_2) : 30 psi 69.3 ft

Unsaturated Zone Calculation:

Definitions:

 l = length of test section $T_u = u - D + H$ u = Thickness of Unsaturated Material D = distance from ground surface to bottom of test section $H = h_1 + h_2 - L$ L = head loss ; ignore if $Q < 4$ gpm $X = \frac{H}{T_u} (100)$; percent unsaturated material

Reference Figure 17-6 U.S. Bureau of Rec. Earth Manual

$$l = 12 \text{ ft}$$

$$T_u = u - D + H = 225 \text{ ft} - 122 \text{ ft} + 195.3 \text{ ft} = 298 \text{ ft}$$

$$\frac{T_u}{l} = \frac{298 \text{ ft}}{12 \text{ ft}} = \boxed{25}$$

$$H = h_1 + h_2 - L = 126 \text{ ft} + 69.3 \text{ ft} - 0 = 195.3 \text{ ft}$$

$$X = \frac{H}{T_u} (100) = \frac{195.3 \text{ ft}}{298 \text{ ft}} (100) = \boxed{65}$$

$$h_1 = 122 \text{ ft} + 4 \text{ ft} = 126 \text{ ft}$$

WATER TESTING FOR PERMEABILITY

- Effective head, the difference in feet (m) between the elevation of the free water surface in the pipe and the elevation of the gauge plus the applied pressure. If a pressure transducer is used, the effective head in the test section is the difference in pressure before water is pumped into the test section and the pressure readings made during the test.

The following examples show some typical calculations using Methods 1 and 2 in the different zones shown in figure 17-5. Figure 17-6 shows the location of the zone 1 lower boundary for use in unsaturated materials.

Pressure permeability tests examples using Methods 1 and 2:

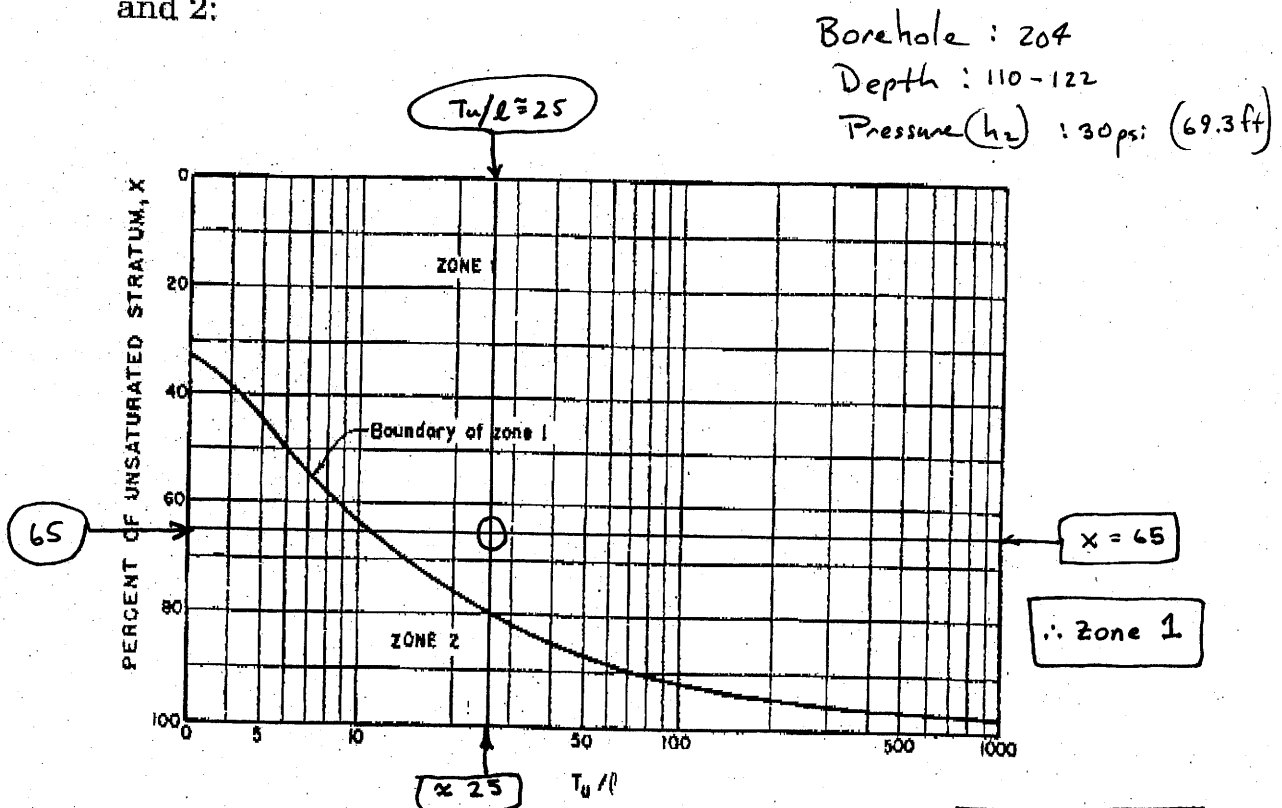

Figure 17-6.—Location of zone 1 lower boundary for use in unsaturated materials.

$$\frac{T_u}{l} = 25$$

$$X = 65$$

WATER TESTING FOR PERMEABILITY

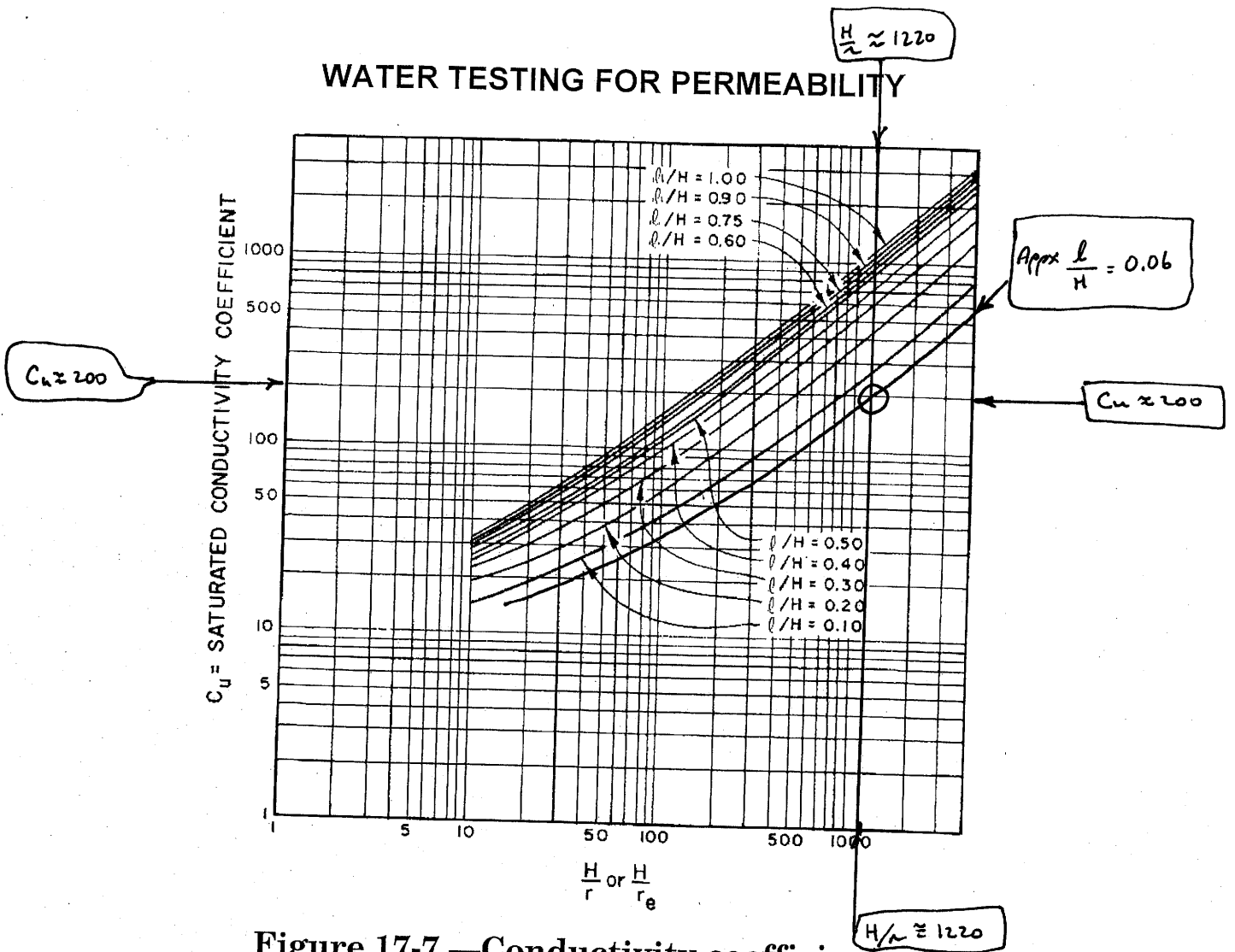

Figure 17-7.—Conductivity coefficients for permeability determination in unsaturated materials with partially penetrating cylindrical test wells.

Zone 2

Given: U , l , r , h_2 , Q , and L are as given in example 1, $D = 65$ feet, and $h_1 = 72$ feet

If the distance from the gauge to the bottom of the intake pipe is 62 feet, the total L is $(6.2)(0.76) = 4.7$ feet.

$$H = 72 + 57.8 - 4.7 = 125.1 \text{ feet}$$

S

Packer Test Set-up Sheet

For straddle packer tests in Zone 1
 - Above water Table -

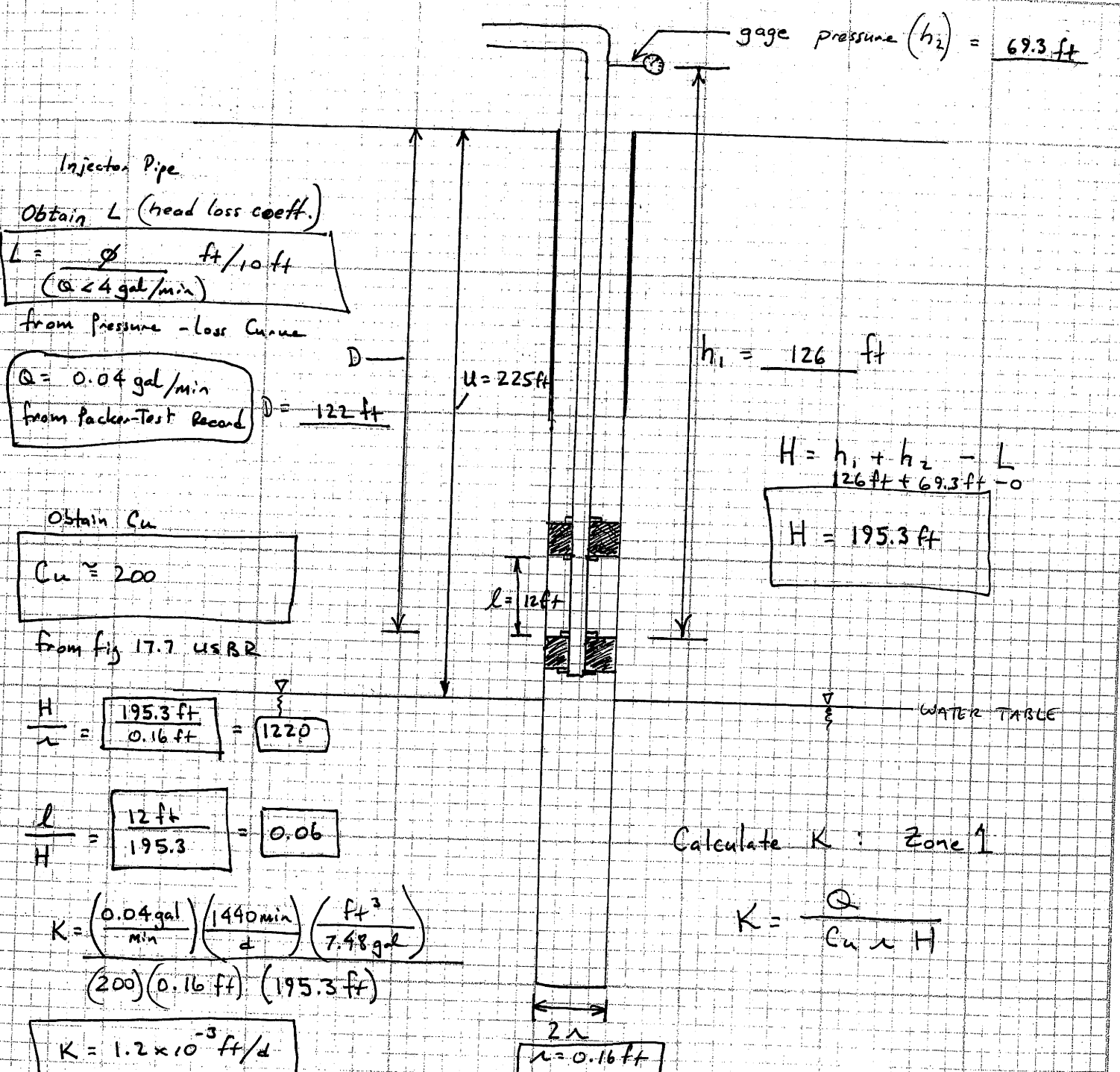

Injector Pipe
 Obtain L (head loss coeff.)
 $L = \phi$ ft/10 ft
 ($Q < 4$ gal/min)
 from Pressure - Loss Curve

$Q = 0.04$ gal/min
 from Packer-Test Record
 $D = 122$ ft

Obtain C_u
 $C_u \approx 200$

from fig 17.7 USBR

$$\frac{H}{L} = \frac{195.3 \text{ ft}}{0.16 \text{ ft}} = 1220$$

$$\frac{l}{H} = \frac{12 \text{ ft}}{195.3} = 0.06$$

$$H = h_1 + h_2 - L$$

$$126 \text{ ft} + 69.3 \text{ ft} - 0$$

$$H = 195.3 \text{ ft}$$

Calculate K : Zone 1

$$K = \frac{(0.04 \text{ gal/min}) (1440 \text{ min}) (ft^3)}{(200) (0.16 \text{ ft}) (195.3 \text{ ft}) (7.48 \text{ gal})}$$

$$K = \frac{Q}{C_u \cdot L \cdot H}$$

$K = 1.2 \times 10^{-3} \text{ ft/d}$
 $K = 4.2 \times 10^{-7} \text{ cm/s}$

$2r$
 $r = 0.16 \text{ ft}$

S

Packer Test Set-up Sheet

For straddle packer tests in Zone 1
 - Above water Table -

Injector Pipe
 Obtain L (head loss coeff.)
 $L = \frac{\phi}{Q} \text{ ft}/10 \text{ ft}$
 $Q < 4 \text{ gpm}$

from Pressure - Loss Curve
 $Q < 0.1 \text{ gal}/10 \text{ min}$
 per packer test Record
 $Q < 0.01 \text{ gal}/\text{min}$

Obtain C_u
 $C_u = 270$

from fig 17.7 USBR

$$\frac{H}{r} = \frac{172.2 \text{ ft}}{0.16 \text{ ft}} = 1076$$

$$\frac{l}{H} = \frac{12 \text{ ft}}{172.2 \text{ ft}} = 0.07$$

$$K < \frac{(0.01 \text{ gal}/\text{min}) \left(\frac{1440 \text{ min}}{\text{day}} \right) \left(\frac{\text{ft}^3}{7.48 \text{ gal}} \right)}{270 (0.16 \text{ ft}) (172.2 \text{ ft})}$$

$$K < 2.6 \times 10^{-4} \text{ ft}/\text{d}$$

$$K < 9.1 \times 10^{-8} \text{ cm}/\text{s}$$

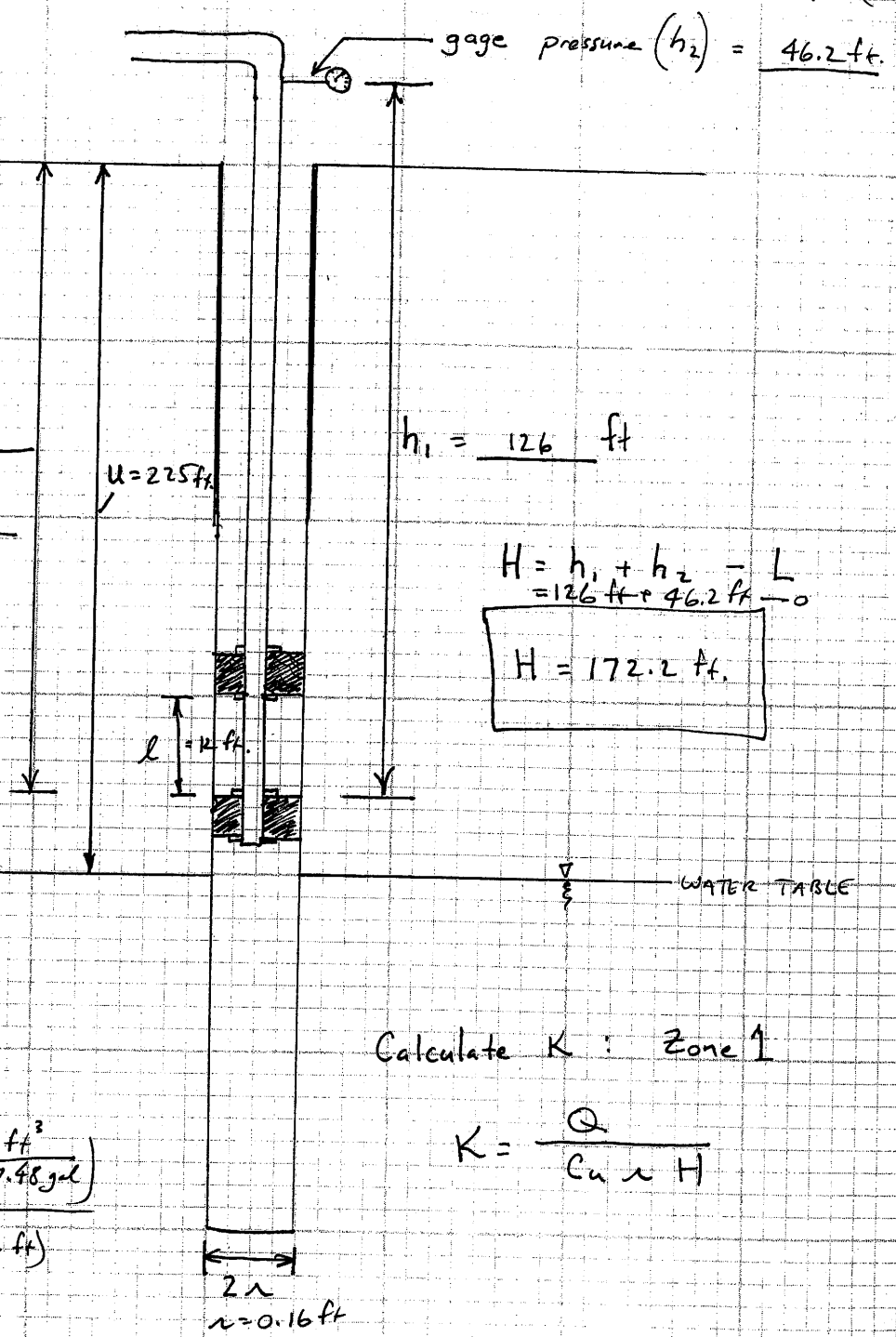

Calculate K: Zone 1

$$K = \frac{Q}{C_u r H}$$

Stoller

Packer Test Set-up Sheet

For straddle packer tests in Zone I
- Above water Table -

JOB NO. _____ DATE: 1-26-06

JOB NAME: Crescent Junction site

PREPARED: M. Kautsky

REVIEWED:

Borehole 204
Depth: 110-122 ft.

SHEET NO. _____ OF _____

Pressure: 10 psi (retest)

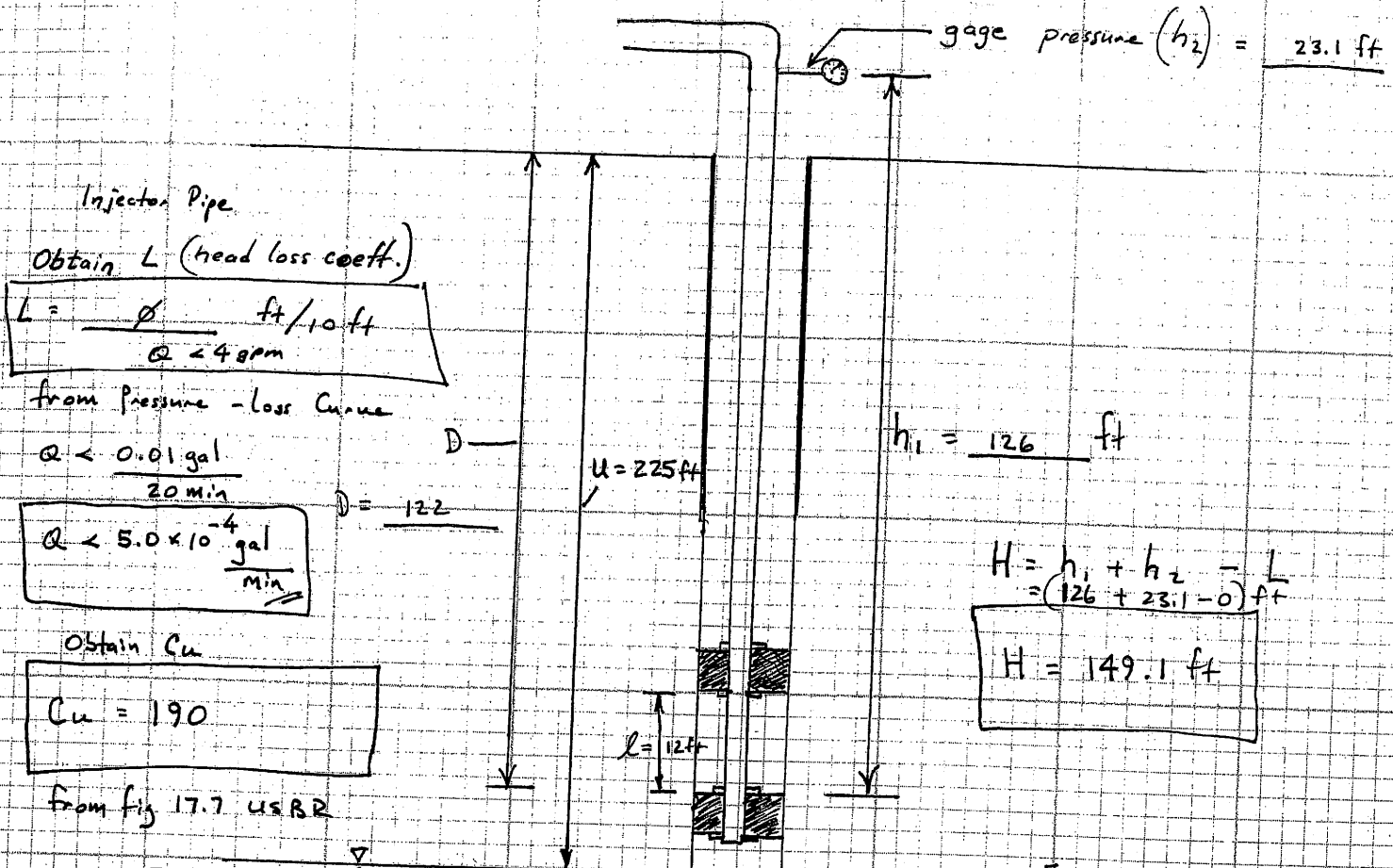

Injector Pipe

Obtain L (head loss coeff.)

$$L = \frac{\phi}{Q} \text{ ft}/10 \text{ ft}$$

$Q < 4 \text{ gpm}$

from Pressure - Loss Curve

$$Q < \frac{0.01 \text{ gal}}{20 \text{ min}}$$

$$Q < 5.0 \times 10^{-4} \frac{\text{gal}}{\text{min}}$$

$$D = 122$$

$$u = 225 \text{ ft}$$

$$h_1 = 126 \text{ ft}$$

$$H = h_1 + h_2 - L = (126 + 23.1 - 0) \text{ ft}$$

$$H = 149.1 \text{ ft}$$

Obtain C_u

$$C_u = 190$$

from fig 17.7 USBR

$$\frac{H}{r} = \frac{149.1 \text{ ft}}{0.16 \text{ ft}} = 932$$

$$\frac{l}{H} = \frac{12 \text{ ft}}{149.1 \text{ ft}} = 0.08$$

Calculate K: Zone 1

$$K = \frac{Q}{C_u r H}$$

$$K < \frac{(5.0 \times 10^{-4} \frac{\text{gal}}{\text{min}}) (\frac{1440 \text{ min}}{\text{day}}) (\frac{\text{ft}^3}{7.48 \text{ gal}})}{(190) (0.16 \text{ ft}) (149.1 \text{ ft})}$$

$$K < 2.1 \times 10^{-5} \text{ ft/day}$$

$$K < 7.5 \times 10^{-9} \frac{\text{cm}}{\text{sec}}$$

$$2r = \dots$$

$$r = 0.16 \text{ ft}$$

Stoller

established 1959

Packer-Test Record

Page 1 of 3

Project Name: Moab-Crescent Jet Manure System Date: 01/13/06

Field Representative: R. Rupp Borehole No. 0204 Total Depth: 300 ft

Depth to Water (TOC): 225 ft Borehole Cleaned? Yes No Date: 01/12/06

Test Interval (BGL): from 283 to 295 ft. Swivel/Elbow Height (AGL) 2.0 ft.

Conductor Pipe, Type and Size: 1-inch ID thin wall steel tubing

Time	Gauge Pressure	Flow Meter Reading	Flow Rate
<u>0953</u>	<u>5 psi</u>	<u>39344.4</u>	
<u>0958</u>	<u>5</u>	<u>39344.4</u>	<u>0</u>
<u>1003</u>	<u>5</u>	<u>39344.4</u>	<u>0</u>
<u>1008</u>	<u>5</u>	<u>39344.4</u>	<u>0</u>
<u>1013</u>	<u>5</u>	<u>39344.4</u>	<u>0</u>
<u>1015</u>	<u>10 psi</u>	<u>39345.2</u>	
<u>1020</u>	<u>10</u>	<u>39345.2</u>	<u>0</u>
<u>1025</u>	<u>10</u>	<u>39345.25</u>	<u>0.01 gpm</u>
<u>1030</u>	<u>10</u>	<u>39345.45</u>	<u>0.04</u>
<u>1035</u>	<u>10</u>	<u>39345.7</u>	<u>0.05</u>
<u>1040</u>	<u>10</u>	<u>39346.05</u>	<u>0.07</u>
<u>1045</u>	<u>10</u>	<u>39346.30</u>	<u>0.05</u>
<u>1050</u>	<u>10</u>	<u>39346.6</u>	<u>0.06</u>
<u>1055</u>	<u>10</u>	<u>39346.85</u>	<u>0.05</u>
<u>1100</u>	<u>10</u>	<u>39347.2</u>	<u>0.07</u>
<u>1105</u>	<u>10</u>	<u>39347.4</u>	<u>0.04</u>
<u>1110</u>	<u>10</u>	<u>39347.7</u>	<u>0.06</u>
<u>1115</u>	<u>10</u>	<u>39348.05</u>	<u>0.07</u>
<u>1120</u>	<u>10</u>	<u>39348.45</u>	<u>0.08</u>
<u>1125</u>	<u>10</u>	<u>39348.8</u>	<u>0.07</u>
<u>1130</u>	<u>10</u>	<u>39349.1</u>	<u>0.06</u>

A-110

Stoller

established 1959

Packer-Test Record

Page 2 of 3

Project Name: MOCK-CONCRETE SET CHAMBER Date: 01/13/06

Field Representative: R. RUPP Borehole No. 0204 Total Depth: 300'

Depth to Water (TOC): 225' Borehole Cleaned? Yes No Date: 01/12/06

Test Interval (BGL): from 283 to 295 ft. Swivel/Elbow Height (AGL) 2.0 ft.

Conductor Pipe, Type and Size: 1-INCH ID THIN WALL STEEL TUBING

Time	Gauge Pressure	Flow Meter Reading	Flow Rate
<u>1140</u>	<u>20 psi</u>	<u>39349.85</u>	<u>0.08 gpm</u>
<u>1145</u>	<u>20</u>	<u>39349.85</u>	<u>0</u>
<u>1150</u>	<u>20</u>	<u>39349.85</u>	<u>0</u>
<u>1155</u>	<u>20</u>	<u>39349.85</u>	<u>0</u>
<u>ADJUST VALVES</u> <u>1200</u>	<u>20</u>	<u>39350.04</u>	
<u>ADJUST VALVES</u> <u>1205</u>	<u>20</u>	<u>39351.2</u>	
<u>1210</u>	<u>20</u>	<u>39351.75</u>	<u>0.11 gpm</u>
<u>1215</u>	<u>20</u>	<u>39352.35</u>	<u>0.12</u>
<u>1220</u>	<u>20</u>	<u>39353.0</u>	<u>0.13</u>
<u>10 min →</u> <u>1230</u>	<u>20</u>	<u>39354.4</u>	<u>0.14</u>
<u>1235</u>	<u>20</u>	<u>39355.1</u>	<u>0.14</u>
<u>1240</u>	<u>20</u>	<u>39355.95</u>	<u>0.17</u>
<u>1245</u>	<u>20</u>	<u>39356.70</u>	<u>0.15</u>
<u>1250</u>	<u>20</u>	<u>39357.60</u>	<u>0.18</u>
<u>1255</u>	<u>20</u>	<u>39358.40</u>	<u>0.16</u>
<u>1300</u>	<u>20</u>	<u>39359.1</u>	<u>0.14</u>
<u>1305</u>	<u>20</u>	<u>39360.0</u>	<u>0.18</u>
<u>1310</u>	<u>20</u>	<u>39360.8</u>	<u>0.16</u>
<u>1315</u>	<u>20</u>	<u>39361.55</u>	<u>0.15</u>
<u>1320</u>	<u>20</u>	<u>39362.4</u>	<u>0.17</u>
<u>1325</u>	<u>20</u>	<u>39363.25</u>	<u>0.17</u>

A-111

Stoller

established 1959

Packer-Test Record

Page 3 of 3

Project Name: Mud-Cement Jet Grouting Date: 01/13/86

Field Representative: R. ROPP Borehole No. 0204 Total Depth: 300'

Depth to Water (TOC): 225' Borehole Cleaned? Yes No Date: 01/12/86

Test Interval (BGL): from 283 to 295 ft. Swivel/Elbow Height (AGL) 2.0'

Conductor Pipe, Type and Size: 1" ID thin wall steel tubing

	Time	Gauge Pressure	Flow Meter Reading	Flow Rate
Adjust Valves	<u>1335</u>	<u>10 psi</u>	<u>39364.0</u>	
	<u>1340</u>	<u>10</u>	<u>39364.0</u>	<u>0</u>
Adjust Valves	<u>1345</u>	<u>10</u>	<u>39364.1</u>	<u>0.02 gpm</u>
	<u>1350</u>	<u>10</u>	<u>39364.1</u>	<u>0</u>
	<u>1355</u>	<u>10</u>	<u>39364.1</u>	<u>0</u>
	<u>1400</u>	<u>10</u>	<u>39364.1</u>	<u>0</u>
	<u>1405</u>	<u>5</u>	<u>39364.0</u>	<u>0</u>
	<u>1410</u>	<u>5</u>	<u>39364.0</u>	<u>0</u>
	<u>1415</u>	<u>5</u>	<u>39364.0</u>	<u>0</u>
	<u>1420</u>	<u>5</u>	<u>39364.0</u>	<u>0</u>

FIELD MANUAL

1-27-06
 Crescent Junction Site.
 Borehole 204
 Depth 283-295
 All pressures

$$T_u = 75 - 65 + 125.1 = 135.1 \text{ feet}$$

$$X = \frac{125.1}{135.1} (100) = 92.6\% \quad \text{also} \quad \frac{T_u}{l} = \frac{135.1}{10} = 13.5$$

The test section is located in zone 2 (figure 17-6). To determine the saturated conductivity coefficient, C_s , from figure 17-8:

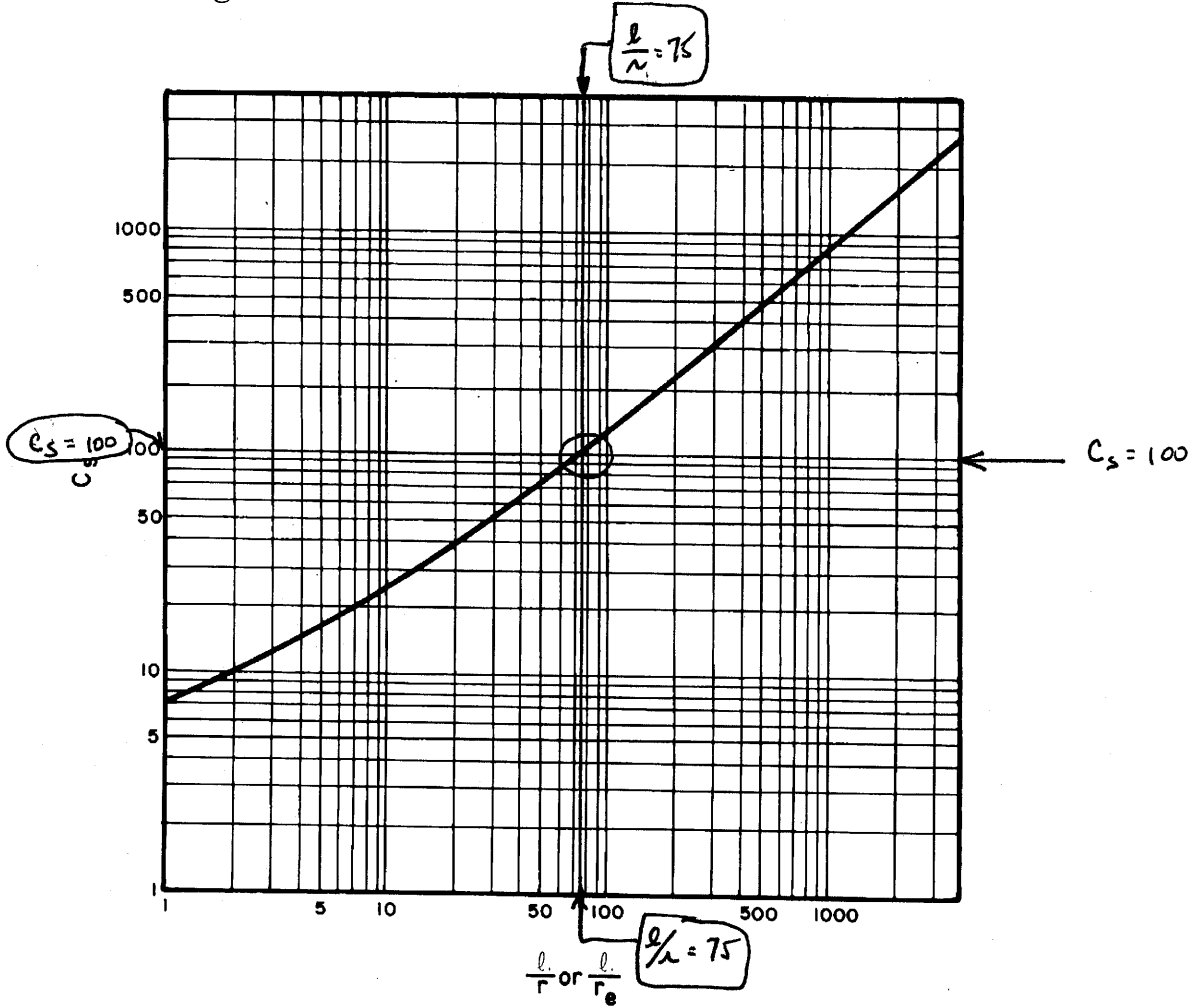

Figure 17-8.—Conductivity coefficients for semispherical flow in saturated materials through partially penetrating cylindrical test wells.

Stoller

For Straddle Pecker Tests below water table
Zone 3; Method 2 USBR

JOB NO.: _____ DATE: 1-27-06

JOB NAME: Crescent Junction site

PREPARED: M. Kautsky

REVIEWED:

Borehole 204
Depth 283-295

SHEET NO.: _____ OF _____

Pressure: 5 psi

Obtain L from
pressure-loss curve
if $Q > 4 \text{ gpm}$

$$L = \begin{cases} \text{ } & Q > 4 \text{ gpm} \\ \text{ } & Q < 4 \text{ gpm} \end{cases}$$

$$Q < \frac{0.01 \text{ gal}}{20 \text{ min}}$$

$$Q < 5 \times 10^{-4} \text{ gal/min}$$

$$D = 295 \text{ ft}$$

$$H = h_1 + h_2 - L$$

$$H = 227 + 11.6 - \text{ } \approx$$

$$H = 238.6 \text{ ft}$$

$$h_1 = 227 \text{ ft}$$

C_s from Figure 17-8

$$\frac{h}{r} = \frac{12 \text{ ft}}{0.16 \text{ ft}} = 75$$

$$C_s = 100$$

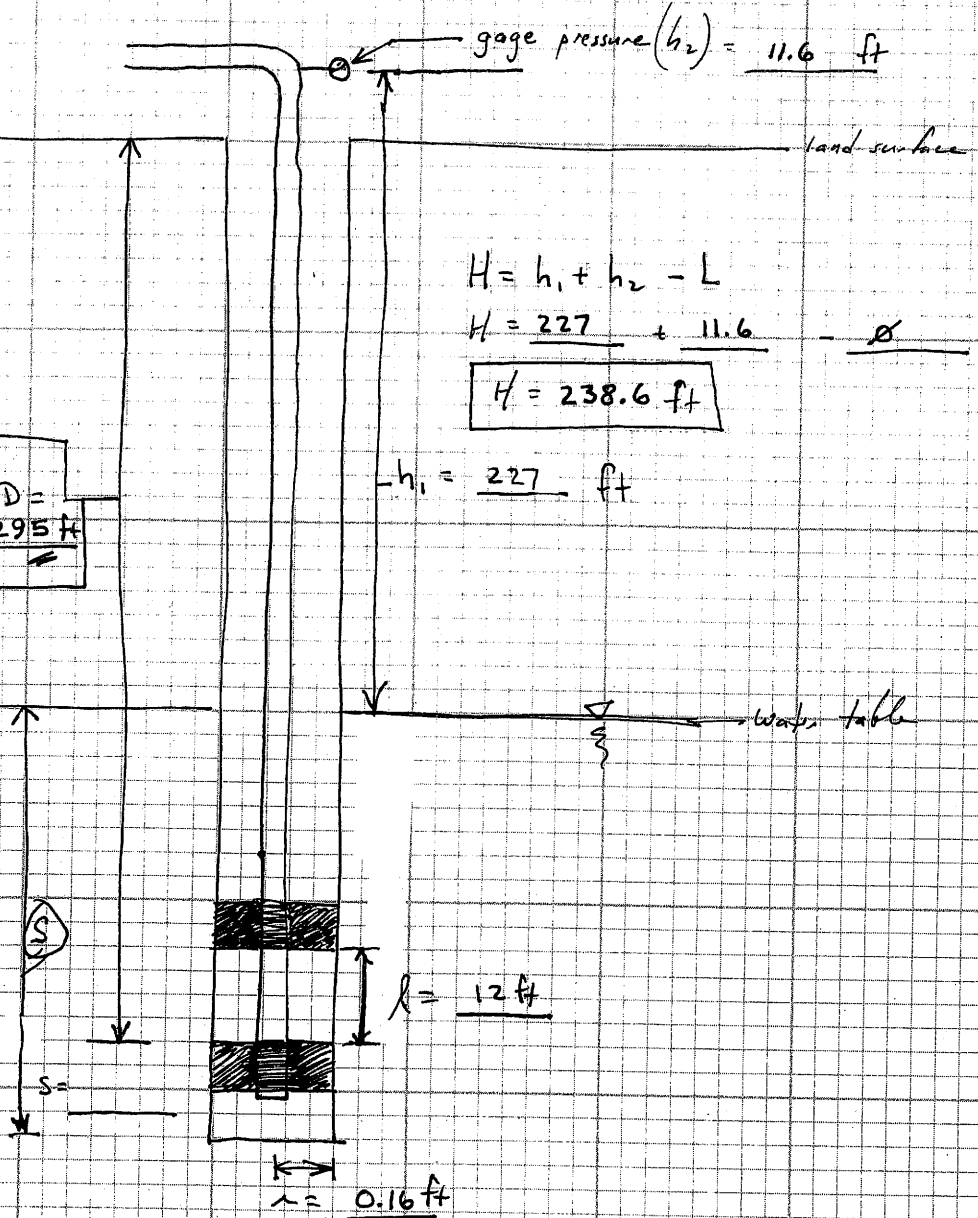

$$K < \frac{Q}{C_s \lambda H}$$

$$K < \frac{(5 \times 10^{-4} \frac{\text{gal}}{\text{min}}) (\frac{1440 \text{ min}}{d}) (\frac{\text{ft}^3}{7.48 \text{ gal}})}{(100) (0.16 \text{ ft}) (238.6 \text{ ft})}$$

$$K < 2.5 \times 10^{-5} \text{ ft/d}$$

$$K < 8.9 \times 10^{-9} \text{ cm/s}$$

Stoller

For Straddle Packer Tests below water table
Zone 3; Method 2 USBR

JOB NO.: _____ DATE: 1-27-06

JOB NAME: Crescent Junction Site

PREPARED: M. Kautsky

REVIEWED:
Borehole 204

SHEET NO.: _____ OF _____

Depth: 283-295
Pressure: 10 psi

Obtain L from
pressure-loss curve
if $Q > 4 \text{ gpm}$

$$L = \begin{cases} \phi & (Q < 4 \text{ gpm}) \end{cases}$$

$$Q = 0.07 \text{ gal/min}$$

$$D = 295$$

$$\text{gage pressure } (h_2) = 23.1 \text{ ft}$$

land surface

$$H = h_1 + h_2 - L$$

$$H = 227 \text{ ft} + 23.1 \text{ ft} - \phi$$

$$H = 250.1 \text{ ft}$$

$$h_1 = 227 \text{ ft}$$

water table

C_s from figure 17-8

$$\frac{l}{r} = \frac{12 \text{ ft}}{0.16 \text{ ft}} = 75$$

$$C_s = 100$$

$$l = 12 \text{ ft}$$

$$r = 0.16 \text{ ft}$$

$$K = \frac{Q}{C_s \cdot l \cdot H}$$

$$K = \frac{(0.07 \text{ gal/min}) \left(\frac{1440 \text{ min}}{d} \right) \left(\frac{1 \text{ ft}^3}{7.48 \text{ gal}} \right)}{(100) (0.16 \text{ ft}) (250.1 \text{ ft})} = 3.4 \times 10^{-3} \text{ ft/d}$$

$$K = 3.4 \times 10^{-3} \text{ ft/d} ; K = 1.2 \times 10^{-6} \text{ cm/s}$$

Stoller

For Straddle Pecker Tests below water table
Zone 3; Method 2 USBR

JOB NO.: _____ DATE: 1-27-06

JOB NAME: Crescent Junction site

PREPARED: M. Kautsky REVIEWED: _____

SHEET NO.: _____ OF _____
Borehole 204
Depth: 283-295 ft
pressure: 20 psi

Obtain L from
pressure-loss curve
if $Q > 4 \text{ gpm}$

$$L = \boxed{\emptyset}$$

($Q < 4 \text{ gal/min}$)

$$Q = 0.17 \text{ gal/min}$$

$$D = 295 \text{ ft}$$

$$\text{gage pressure } (h_2) = 46.2 \text{ ft}$$

land surface

$$H = h_1 + h_2 - L$$

$$H = 227 + 46.2 - \emptyset$$

$$H = 273.2 \text{ ft}$$

$$h_1 = 227 \text{ ft}$$

water table

C_s from figure 17-8

$$\frac{l}{r} = \frac{12 \text{ ft}}{0.16 \text{ ft}} = 75$$

$$C_s = 100$$

$$l = 12 \text{ ft}$$

$$r = 0.16 \text{ ft}$$

$$K = \frac{Q}{C_s \cdot l \cdot H}$$

$$K = \frac{(0.17 \text{ gal/min}) \left(\frac{1440 \text{ min}}{d} \right) \left(\frac{1 \text{ ft}^3}{7.48 \text{ gal}} \right)}{(100) (0.16 \text{ ft}) (273.2 \text{ ft})}$$

$$K = 7.5 \times 10^{-3} \text{ ft/d}$$

$$K = 2.6 \times 10^{-6} \text{ cm/s}$$

Stoller

For Straddle Pecker Tests below water table
Zone 3; Method 2 USBR

JOB NO.: _____ DATE: 1-27-06

JOB NAME: Crescent Junction site

PREPARED: Mark Kautsky REVIEWED: _____

SHEET NO.: _____ OF _____
Borehole: 204
Depth: 283-295 ft.
pressure: 10 psi (retest)

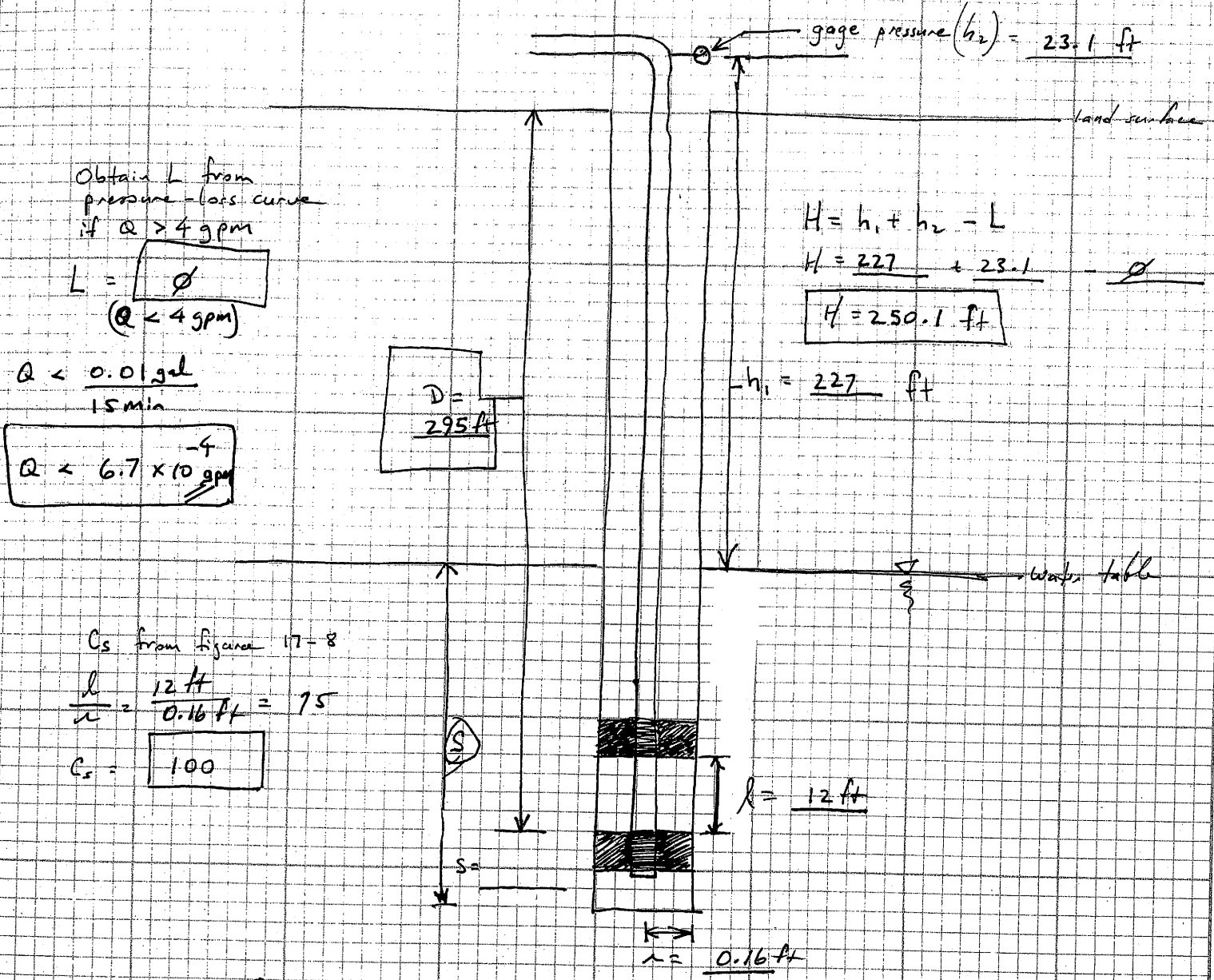

Obtain L from
pressure-loss curve
if $Q > 4 \text{ gpm}$

$$L = \begin{cases} \phi & (Q < 4 \text{ gpm}) \end{cases}$$

$$Q < \frac{0.01 \text{ gal}}{15 \text{ min}}$$

$$Q < 6.7 \times 10^{-4} \text{ gpm}$$

$$D = 295 \text{ ft}$$

$$H = h_1 + h_2 - L$$

$$H = 227 + 23.1 - \phi$$

$$H = 250.1 \text{ ft}$$

$$h_1 = 227 \text{ ft}$$

C_s from figure 17-8

$$\frac{l}{r} = \frac{12 \text{ ft}}{0.16 \text{ ft}} = 75$$

$$C_s = 100$$

$$K = \frac{Q}{C_s \cdot l \cdot H}$$

$$K < \frac{(6.7 \times 10^{-4} \frac{\text{gal}}{\text{min}}) (1440 \frac{\text{min}}{\text{d}}) (\frac{\text{ft}^3}{7.48 \text{ gal}})}{(100) (0.16 \text{ ft}) (250.1 \text{ ft})}$$

$$K < 3.2 \times 10^{-5} \text{ ft/d}$$

$$K < 1.1 \times 10^{-8} \text{ cm/s}$$

Stoller

For Straddle Pecker Tests below water table
Zone 3; Method 2 USBR

JOB NO.: _____ DATE: 1-27-06

JOB NAME: Crescent Junction site

PREPARED: Mark Rautsky REVIEWED: _____
Borehole 204
Depth: 283-295 ft
pressure: 5 psi (retest)

SHEET NO.: _____ OF _____

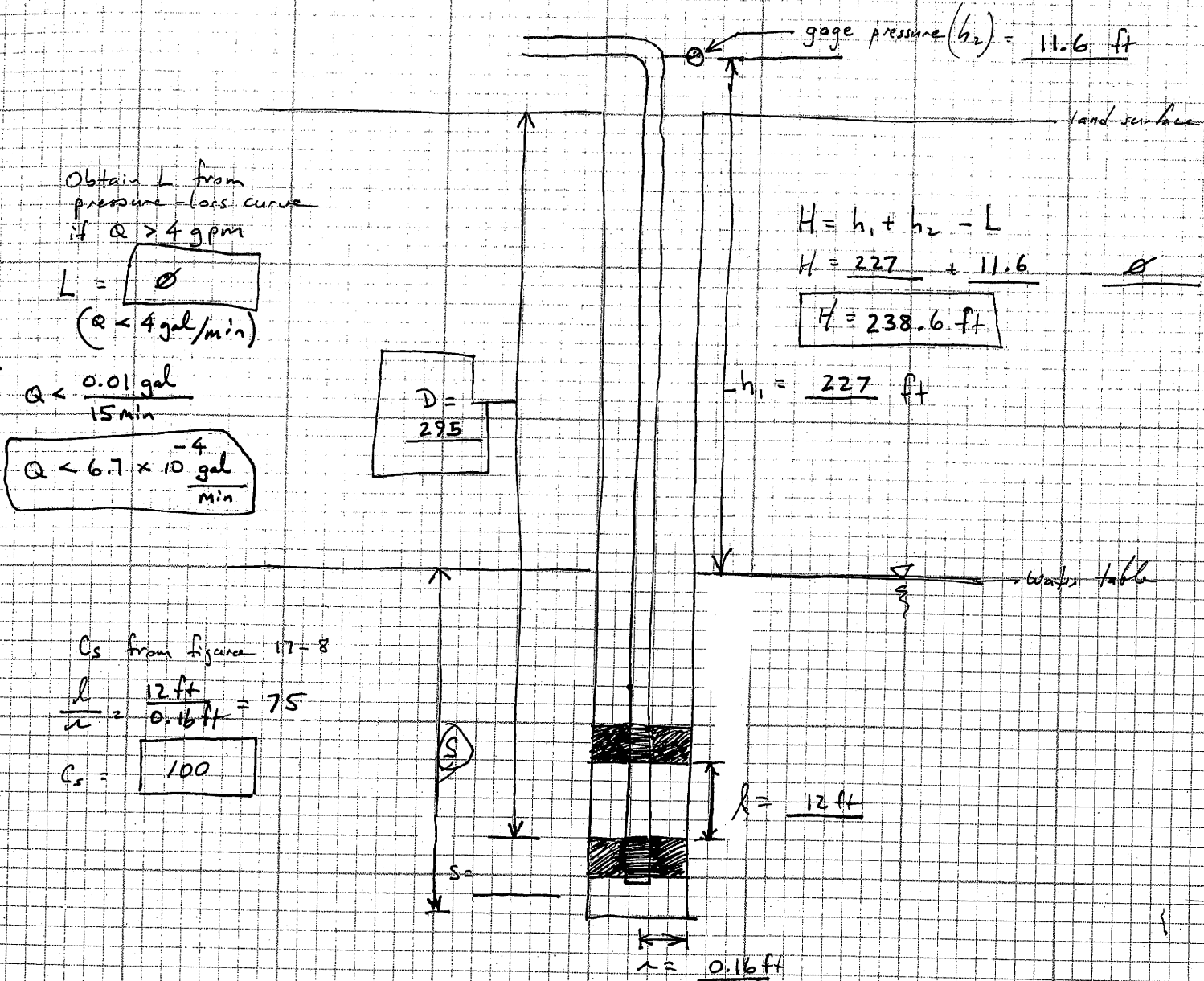

Obtain L from pressure-loss curve if $Q > 4$ gpm

$$L = \boxed{\emptyset}$$

($Q < 4$ gal/min)

$$Q < \frac{0.01 \text{ gal}}{15 \text{ min}}$$

$$Q < 6.7 \times 10^{-4} \frac{\text{gal}}{\text{min}}$$

$$D = \boxed{295}$$

$$H = h_1 + h_2 - L$$

$$H = 227 + 11.6 - \emptyset$$

$$H = \boxed{238.6 \text{ ft}}$$

$$h_1 = \boxed{227 \text{ ft}}$$

C_s from figure 17-8

$$\frac{d}{r} = \frac{12 \text{ ft}}{0.16 \text{ ft}} = 75$$

$$C_s = \boxed{100}$$

$$r = \boxed{12 \text{ ft}}$$

$$s = \boxed{0.16 \text{ ft}}$$

$$K = \frac{Q}{C_s \cdot r \cdot H}$$

$$K < \frac{(6.7 \times 10^{-4} \frac{\text{gal}}{\text{min}}) (1440 \text{ min}) (1 \text{ ft}^3)}{(100) (0.16 \text{ ft}) (238.6 \text{ ft}) (7.48 \text{ gal})}$$

$$K < 3.4 \times 10^{-5} \text{ ft/d}$$

$$K < 1.2 \times 10^{-8} \text{ cm/a}$$

Stoller

established 1959

Packer-Test Record

Page 1 of 2

Project Name: Mead - Crescent Jet Characterization Date: 01/16/66

Field Representative: R. Rupp Borehole No. 0208 Total Depth: 300 ft

Depth to Water (TOC): 187.5 ft Borehole Cleaned? Yes No Date: 01/15/66

Test Interval (BGL): from 90 to 102 ft. Swivel/Elbow Height (AGL) 4.5 ft.

Conductor Pipe, Type and Size: 1-inch ID thin wall steel tubing

Time	Gauge Pressure	Flow Meter Reading	Flow Rate
<u>0800</u>	<u>10 psi</u>	<u>39421.70</u>	
<u>0805</u>	<u>10</u>	<u>39421.70</u>	<u>0</u>
<u>0810</u>	<u>10</u>	<u>39421.70</u>	<u>0</u>
<u>0815</u>	<u>10</u>	<u>39421.70</u>	<u>0</u>
<u>0820</u>	<u>10</u>	<u>39421.70</u>	<u>0</u>
<u>0825</u>	<u>10</u>	<u>39421.70</u>	<u>0</u>
<u>0830</u>	<u>10</u>	<u>39421.70</u>	<u>0 gpm</u>
<u>0835</u>	<u>20 psi</u>	<u>39422.40</u>	<u>0.14</u>
<u>0840</u>	<u>20</u>	<u>39422.40</u>	<u>0</u>
<u>0845</u>	<u>20</u>	<u>39422.35</u>	<u>-0.01</u>
<u>0850</u>	<u>20</u>	<u>39422.35</u>	<u>0</u>
<u>0855</u>	<u>20</u>	<u>39422.35</u>	<u>0</u>
<u>0900</u>	<u>20</u>	<u>39422.35</u>	<u>0</u>
<u>0905</u>	<u>20</u>	<u>39422.35</u>	<u>0 gpm</u>
<u>0910</u>	<u>30 psi</u>	<u>39422.75</u>	<u>0.08</u>
<u>0915</u>	<u>30</u>	<u>39422.75</u>	<u>0</u>
<u>0920</u>	<u>30</u>	<u>39422.75</u>	<u>0</u>
<u>0925</u>	<u>30</u>	<u>39422.75</u>	<u>0</u>

Stoller

established 1959

Packer-Test Record

Page 2 of 2

Project Name: Moab - Crescent Jct. Chem. Station Date: 01/16/06

Field Representative: R. Rupp Borehole No. 0208 Total Depth: 300 ft.

Depth to Water (TOC): 187.5 ft. Borehole Cleaned? Yes No Date: 01/15/06

Test Interval (BGL): from 90 to 102 ft. Swivel/Elbow Height (AGL) 4.5 ft.

Conductor Pipe, Type and Size: 1-inch ID Thin Wall steel Tubing

Time	Gauge Pressure	Flow Meter Reading	Flow Rate
<u>0930</u>	<u>30 psi</u>	<u>39422.75</u>	<u>0</u>
<u>0935</u>	<u>30</u>	<u>39422.75</u>	<u>0</u>
<u>0940</u>	<u>30</u>	<u>39422.75</u>	<u>0 gpm</u>
<u>0945</u>	<u>20 psi</u>	<u>39422.70</u>	<u>-0.01</u>
<u>0950</u>	<u>20</u>	<u>39422.70</u>	<u>0</u>
<u>0955</u>	<u>20</u>	<u>39422.70</u>	<u>0</u>
<u>1000</u>	<u>20</u>	<u>39422.70</u>	<u>0</u>
<u>1005</u>	<u>20</u>	<u>39422.70</u>	<u>0</u>
<u>1010</u>	<u>20</u>	<u>39422.70</u>	<u>0</u>
<u>1015</u>	<u>20</u>	<u>39422.70</u>	<u>0</u>
<u>1020</u>	<u>10 psi</u>	<u>39422.70</u>	<u>0</u>
<u>1025</u>	<u>10</u>	<u>39422.70</u>	<u>0</u>
<u>1030</u>	<u>10</u>	<u>39422.70</u>	<u>0</u>
<u>1035</u>	<u>10</u>	<u>39422.70</u>	<u>0</u>
<u>1040</u>	<u>10</u>	<u>39422.70</u>	<u>0</u>
<u>1045</u>	<u>10</u>	<u>39422.70</u>	<u>0</u>
<u>1050</u>	<u>10</u>	<u>39422.70</u>	<u>0</u>

Stoller

1-23-06

PROJECT: Crescent Junction

PREPARED: M. Kautsley

REVIEWED:

SHEET NO. OF

PACKER TEST ANALYSES

BOREHOLE: 208

Depth: 90-102 ft

Unsaturated Zone Calculation:

Pressure (h_2): 10 psi ($h_2 = 23.1$ ft)

Definitions: L = length of test section

$$T_u = U - D + H$$

U = Thickness of Unsaturated Material

D = distance from ground surface to bottom of test section

$$H = h_1 + h_2 - L$$

L = head loss; ignore if $Q < 4$ gpm

$X = \frac{H}{T_u} (100)$; percent unsaturated material

Reference Figure 17-6 U.S. Bureau of Rec. Earth Manual

$$L = 12 \text{ ft}$$

$$T_u = U - D + H = 187.5 \text{ ft} - 102 \text{ ft} + 129.6 \text{ ft} = 215.1 \text{ ft}$$

$$\frac{T_u}{L} = \frac{215 \text{ ft}}{12 \text{ ft}} = \boxed{17.9}$$

$$H = h_1 + h_2 - \underbrace{L}_{Q < 4 \text{ gpm}} = 106.5 \text{ ft} + 23.1 \text{ ft} - 0 = 129.6 \text{ ft}$$

$$X = \frac{H}{T_u} (100) = \frac{129.6 \text{ ft}}{215.1 \text{ ft}} (100) = \boxed{60.2}$$

$$h_1 = (102 + 4.5) \text{ ft} = 106.5 \text{ ft}$$

WATER TESTING FOR PERMEABILITY

- Effective head, the difference in feet (m) between the elevation of the free water surface in the pipe and the elevation of the gauge plus the applied pressure. If a pressure transducer is used, the effective head in the test section is the difference in pressure before water is pumped into the test section and the pressure readings made during the test.

The following examples show some typical calculations using Methods 1 and 2 in the different zones shown in figure 17-5. Figure 17-6 shows the location of the zone 1 lower boundary for use in unsaturated materials.

Pressure permeability tests examples using Methods 1 and 2:

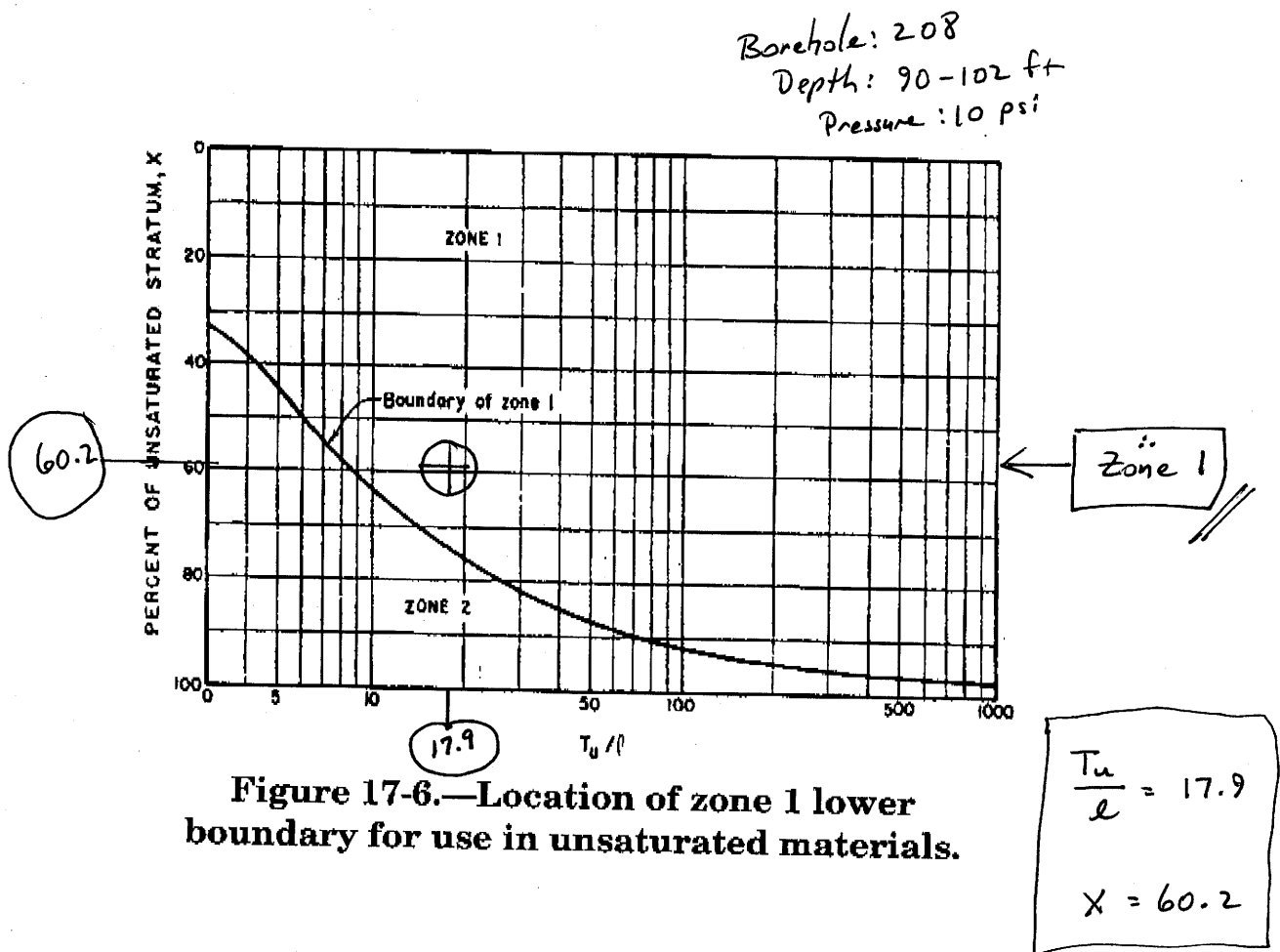

WATER TESTING FOR PERMEABILITY

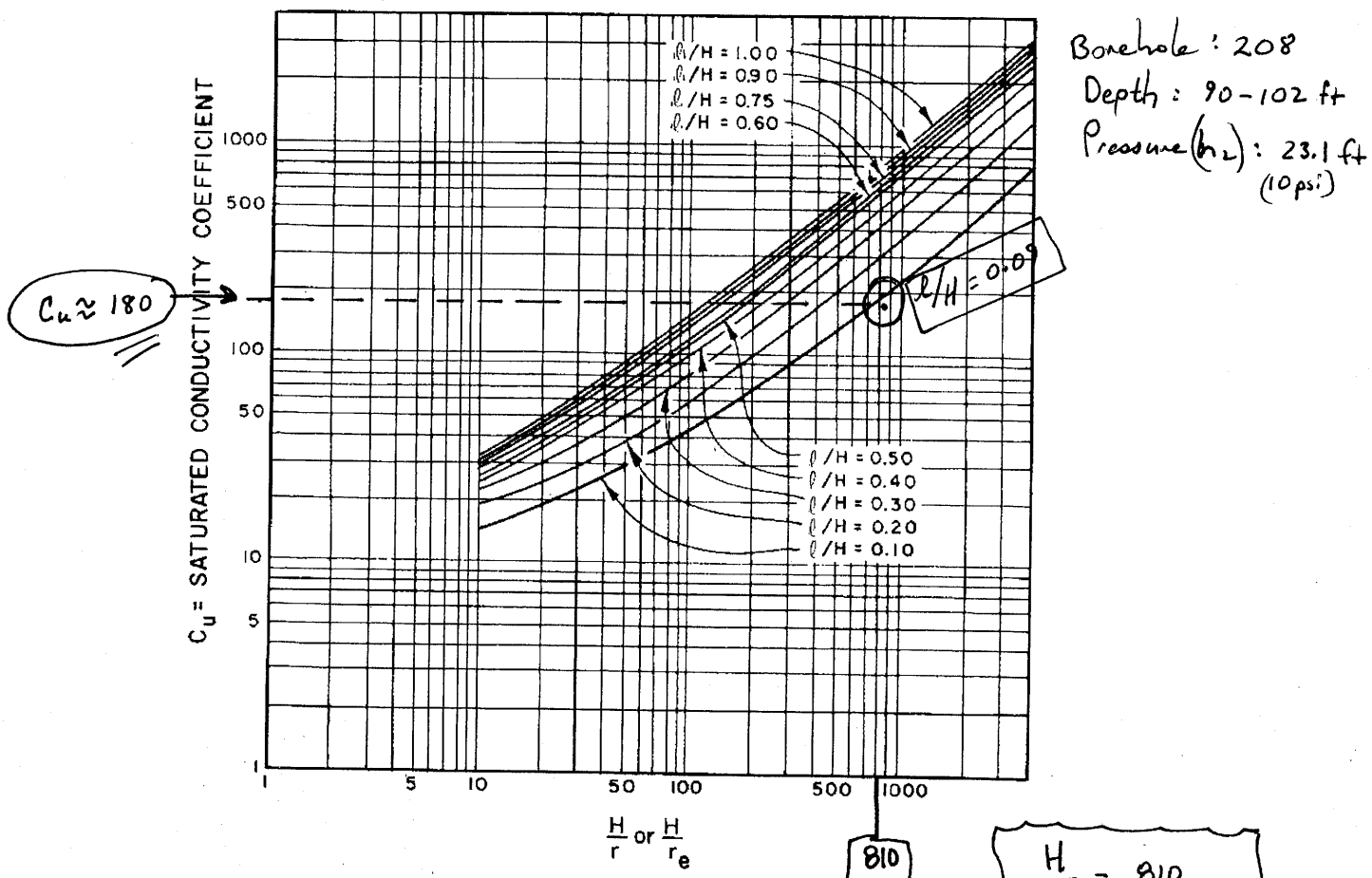

Figure 17-7.—Conductivity coefficients for permeability determination in unsaturated materials with partially penetrating cylindrical test wells.

$$\frac{H}{l} = 810$$

$$\frac{l}{H} = 0.09$$

Zone 2

Given: U , l , r , h_2 , Q , and L are as given in example 1, $D = 65$ feet, and $h_1 = 72$ feet

If the distance from the gauge to the bottom of the intake pipe is 62 feet, the total L is $(6.2)(0.76) = 4.7$ feet.

$$H = 72 + 57.8 - 4.7 = 125.1 \text{ feet}$$

S

Packer Test Set-up Sheet

For straddle packer tests in Zone 1
- Above water Table -

JOB NO: Borehole: 208 DATE: _____
 JOB NAME: Depth: 90-102 ft
 PREPARED: Pressure (h_2): 23.1 ft REVIEWED: _____
 SHEET NO: Crescent Junction Side

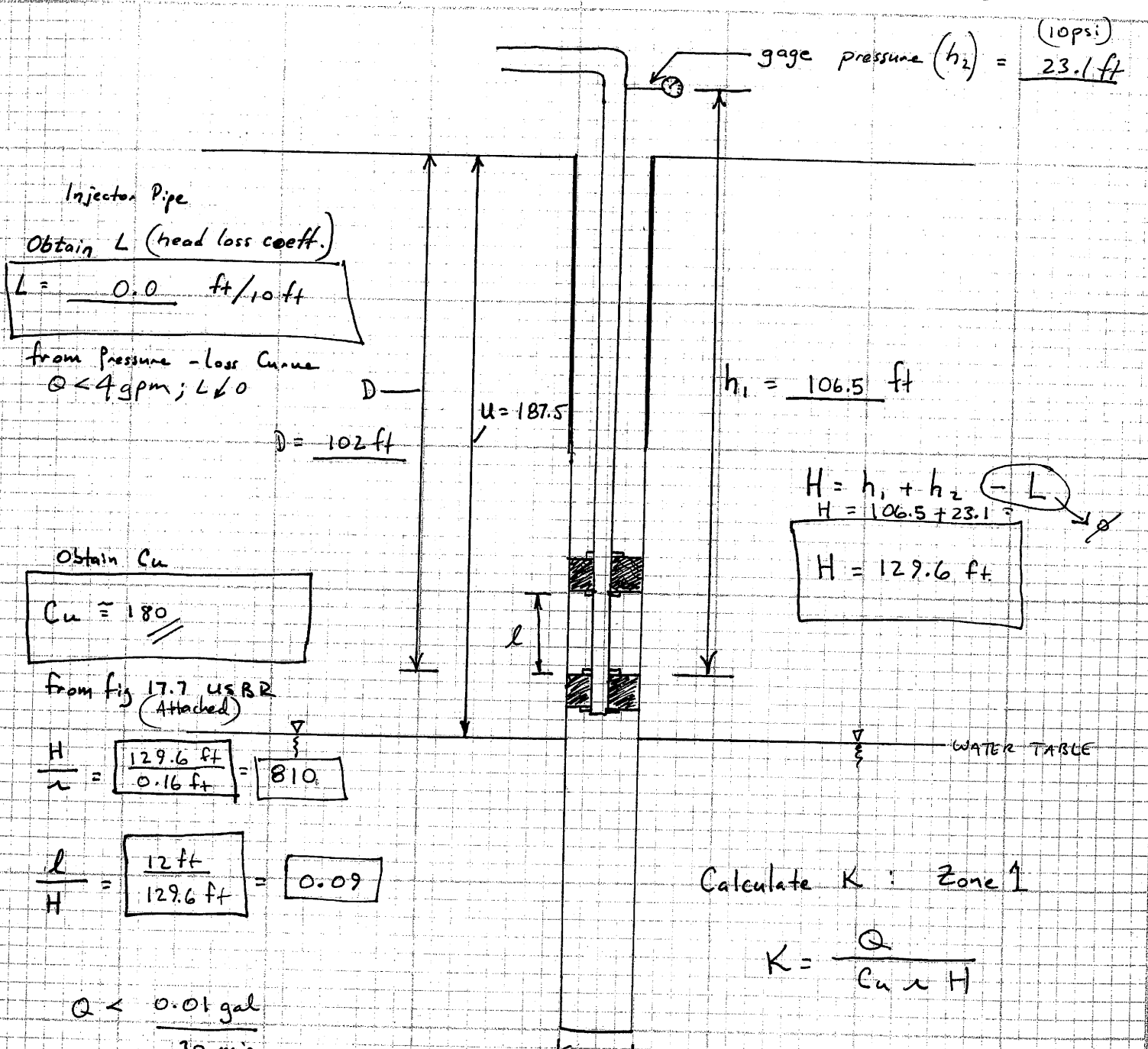

Injector Pipe
Obtain L (head loss coeff.)
 $L = 0.0$ ft/10 ft
 from Pressure - Loss Curve
 $Q < 4$ gpm; $L < 0$

Obtain C_u
 $C_u \approx 180$
 from fig 17.7 USBR
 (Attached)

$$\frac{H}{r} = \frac{129.6 \text{ ft}}{0.16 \text{ ft}} = 810$$

$$\frac{l}{H} = \frac{12 \text{ ft}}{129.6 \text{ ft}} = 0.09$$

$$Q < \frac{0.01 \text{ gal}}{30 \text{ min}}$$

$$Q < 3.33 \times 10^{-4} \text{ gpm}$$

$$K < \frac{3.33 \times 10^{-4} \text{ gal/min} \left(\frac{1440 \text{ min}}{d} \right) \left(\frac{1 \text{ ft}^3}{7.48 \text{ gal}} \right)}{(180)(0.16 \text{ ft})(129.6 \text{ ft})}$$

$$K < 1.7 \times 10^{-5} \text{ ft/d}$$

$$K < 6 \times 10^{-9} \text{ cm/s}$$

$$H = h_1 + h_2 - L$$

$$H = 106.5 + 23.1 = 129.6 \text{ ft}$$

Calculate K : Zone 1

$$K = \frac{Q}{C_u \cdot H}$$

$$K < \frac{3.33 \times 10^{-4} \text{ gal/min} \cdot 7.48 \text{ ft}^3}{(180)(0.16 \text{ ft})(129.6 \text{ ft})(7.48 \text{ gal})}$$

S 10107

PROJECT: Crescent Junction

PREPARED: M. Kautsky

REVIEWED:

SHEET NO. OF

PACKER TEST ANALYSES

BOREHOLE: 208

Depth: 90-102

Pressure (h_2): 20psi ($h_2 = 46.2$ ft)

Unsaturated Zone Calculation:

Definitions:

 l = length of test section $T_u = u - D + H$ u = Thickness of Unsaturated Material D = distance from ground surface to bottom of test section $H = h_1 + h_2 - L$ L = head loss; ignore if $Q < 4$ gpm $X = \frac{H}{T_u} (100)$; percent unsaturated material

Reference Figure 17-6 U.S. Bureau of Rec. Earth Manual

$$l = 12 \text{ ft}$$

$$T_u = u - D + H = 187.5 \text{ ft} - 102 \text{ ft} + 152.7 \text{ ft} = 238.2 \text{ ft}$$

$$\frac{T_u}{l} = \frac{238.2 \text{ ft}}{12. \text{ ft}} = \boxed{19.8}$$

$$H = h_1 + h_2 \underset{\substack{\text{0} \\ (Q < 4 \text{ gpm})}}{\text{- } L} = 106.5 + 46.2 = 152.7 \text{ ft}$$

$$X = \frac{H}{T_u} (100) = \frac{152.7 \text{ ft}}{238.2 \text{ ft}} = 0.64 (100) = \boxed{64}$$

$$h_1 = (102 + 4.5) \text{ ft} = 106.5 \text{ ft}$$

WATER TESTING FOR PERMEABILITY

- Effective head, the difference in feet (m) between the elevation of the free water surface in the pipe and the elevation of the gauge plus the applied pressure. If a pressure transducer is used, the effective head in the test section is the difference in pressure before water is pumped into the test section and the pressure readings made during the test.

The following examples show some typical calculations using Methods 1 and 2 in the different zones shown in figure 17-5. Figure 17-6 shows the location of the zone 1 lower boundary for use in unsaturated materials.

Pressure permeability tests examples using Methods 1 and 2:

Borehole : 208
Depth : 90-102
Pressure (h_2) : 20 psi

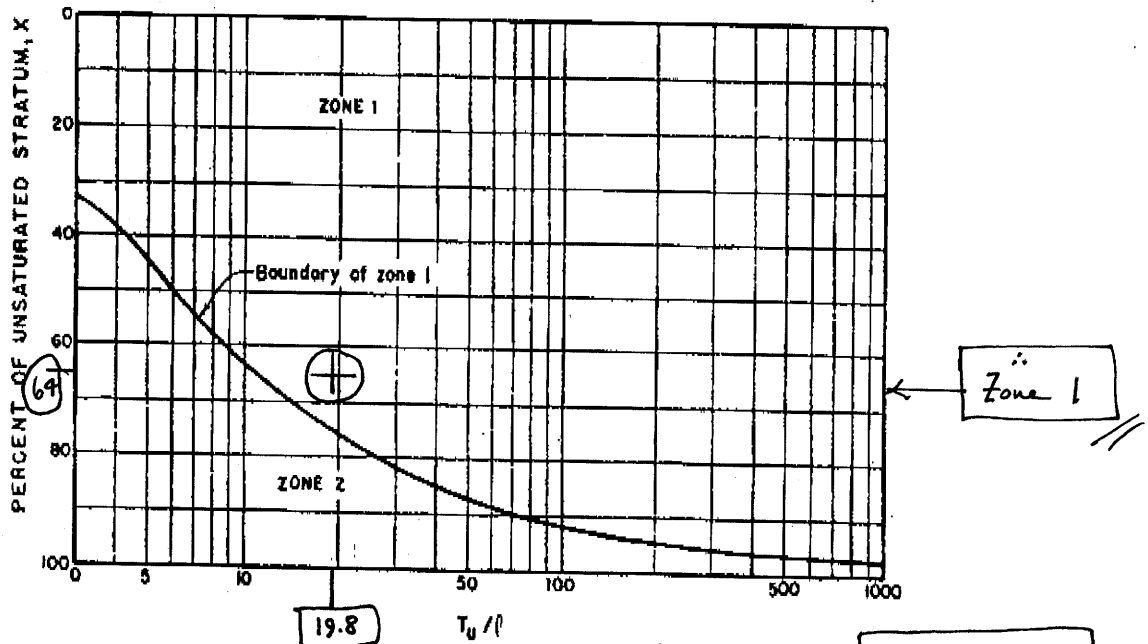

Figure 17-6.—Location of zone 1 lower boundary for use in unsaturated materials.

$$\frac{T_u}{l} = 19.8$$

$$X = 64$$

WATER TESTING FOR PERMEABILITY

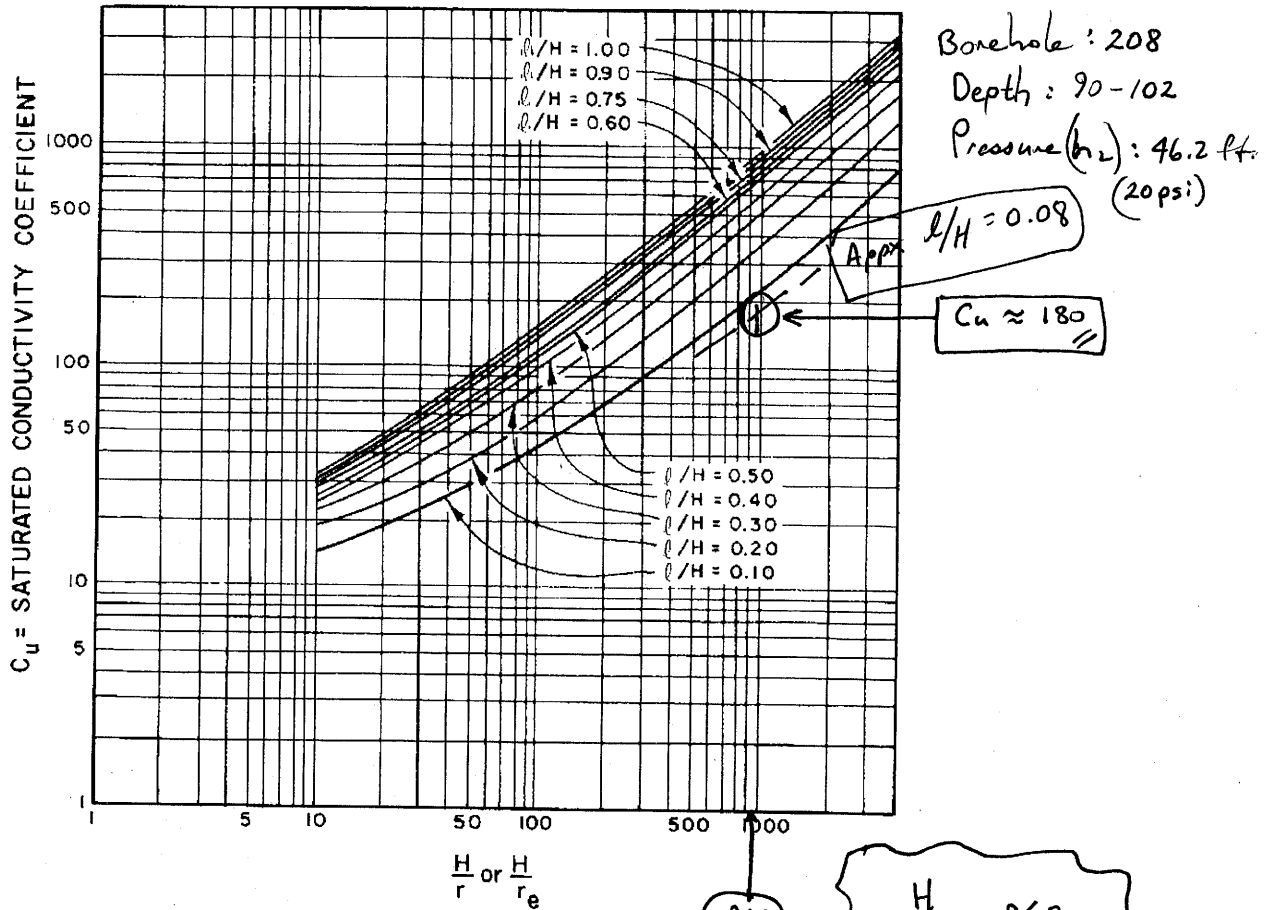

Figure 17-7.—Conductivity coefficients for permeability determination in unsaturated materials with partially penetrating cylindrical test wells.

$$\frac{H}{r} = 968.2$$

$$\frac{l}{H} = 0.08$$

Zone 2

Given: U , l , r , h_2 , Q , and L are as given in example 1, $D = 65$ feet, and $h_1 = 72$ feet

If the distance from the gauge to the bottom of the intake pipe is 62 feet, the total L is $(6.2)(0.76) = 4.7$ feet.

$$H = 72 + 57.8 - 4.7 = 125.1 \text{ feet}$$

S

Packer Test Set-up Sheet

For straddle packer tests in Zone 1
- Above water Table -

JOB NO: Borehole 208

DATE: _____

JOB NAME: Depth 90-102 ft.

PREPARED: Pressure (h_2) = 46.2 ft (20psi) REVIEWED: _____

SHEET NO. _____ OF _____

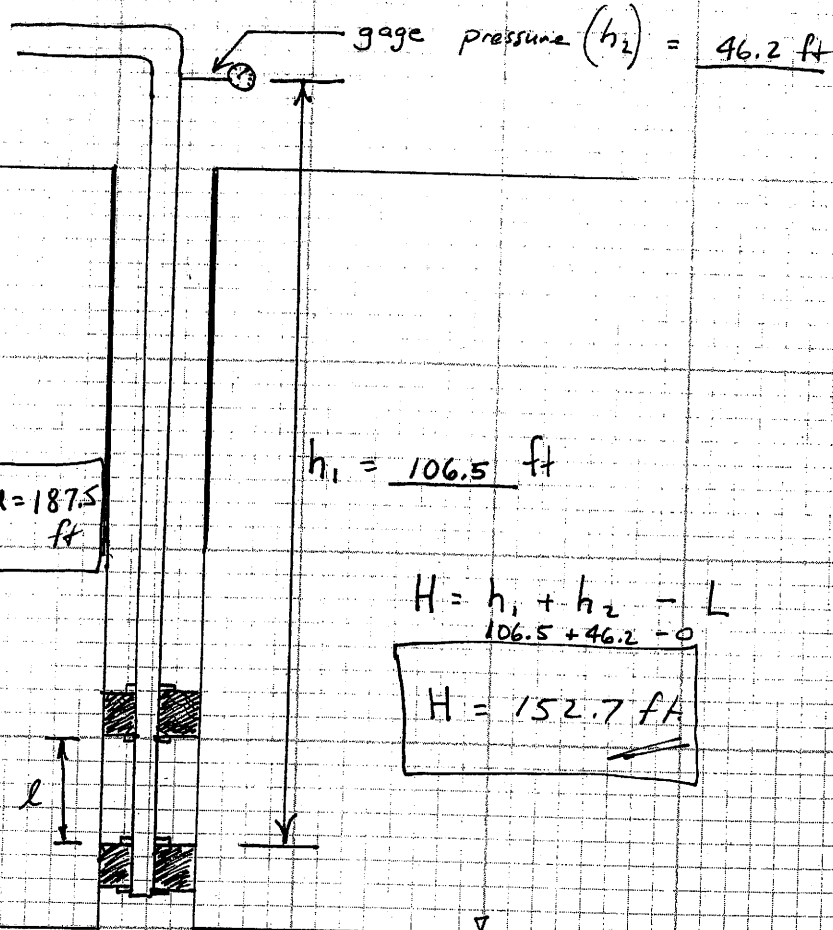

Injector Pipe
Obtain L (head loss coeff.)
 $L = \frac{\phi}{Q} \text{ ft}/10 \text{ ft}$
($Q < 4.9 \text{ gpm}$)
from Pressure - Loss Curve

Obtain C_u
 $C_u \approx 180$

from fig 17.7 USBR (Attached)

$$\frac{H}{L} = \frac{152.7 \text{ ft}}{0.16 \text{ ft}} = 968.2$$

$$\frac{l}{H} = \frac{12 \text{ ft}}{152.7 \text{ ft}} = 0.08$$

$$Q < 0.01 \text{ gal}/20 \text{ min}$$

$$Q < 5.0 \times 10^{-4} \text{ gal}/\text{min}$$

$$K < \frac{(5.0 \times 10^{-4} \text{ gal}/\text{min}) \left(\frac{1440 \text{ min}}{d} \right) \left(\frac{1 \text{ ft}^3}{7.48 \text{ gal}} \right)}{(180)(0.16 \text{ ft})(152.7 \text{ ft})}$$

Calculate K : Zone 1

$$K = \frac{Q}{C_u \cdot L \cdot H}$$

$$2r = 3.785''$$

$$r = 0.16 \text{ ft.}$$

$$K < 2.2 \times 10^{-5} \text{ ft}/\text{d}$$

$$K < 7.7 \times 10^{-9} \text{ cm}/\text{s}$$

SLOTT

JOB TITLE: Crescent Junction

PREPARED: M. Kautsky

REVIEWED:

SHEET NO. OF

PACKER TEST ANALYSES

BOREHOLE : 208

Depth : 90-102 ft

Pressure (h_2) : 30psi $h_2 = 69.3$ ft

Unsaturated Zone Calculation:

Definitions:

 L = length of test section $T_u = u - D + H$ u = Thickness of Unsaturated Material D = distance from ground surface to bottom of test section $H = h_1 + h_2 - L$ L = head loss ; ignore if $Q < 4$ gpm $X = \frac{H}{T_u} (100)$; percent unsaturated material

Reference Figure 17-6 U.S. Bureau of Rec. Earth Manual

$$L = 12 \text{ ft}$$

$$T_u = u - D + H = 187.5 \text{ ft} - 102 \text{ ft} + 175.8 \text{ ft} = 261.3 \text{ ft}$$

$$\frac{T_u}{L} = \frac{261.3 \text{ ft}}{12 \text{ ft}} = 21.8$$

$$H = h_1 + h_2 \begin{matrix} \text{Q} < 4 \text{ gpm} \\ \swarrow \\ \downarrow \\ \searrow \\ 0 \end{matrix} = h_1 + h_2 = 106.5 \text{ ft} + 69.3 \text{ ft} = 175.8 \text{ ft}$$

$$X = \frac{H}{T_u} (100) = \frac{175.8 \text{ ft}}{261.3 \text{ ft}} (100) = 67.3$$

$$h_1 = (102 + 4.5) \text{ ft} = 106.5 \text{ ft}$$

WATER TESTING FOR PERMEABILITY

- Effective head, the difference in feet (m) between the elevation of the free water surface in the pipe and the elevation of the gauge plus the applied pressure. If a pressure transducer is used, the effective head in the test section is the difference in pressure before water is pumped into the test section and the pressure readings made during the test.

The following examples show some typical calculations using Methods 1 and 2 in the different zones shown in figure 17-5. Figure 17-6 shows the location of the zone 1 lower boundary for use in unsaturated materials.

Pressure permeability tests examples using Methods 1 and 2:

Borehole : 208
 Depth : 90-102 ft
 Pressure (h_2) : 30psi (69.3ft)
 (= h_2)

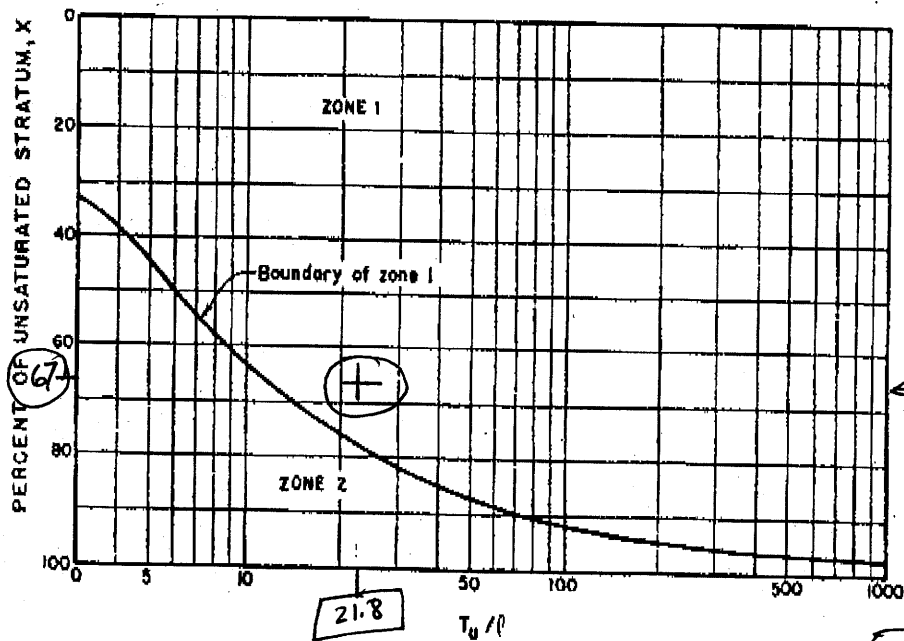

Figure 17-6.—Location of zone 1 lower boundary for use in unsaturated materials.

$$\frac{T_u}{l} = 21.8$$

$$X = 67.3$$

WATER TESTING FOR PERMEABILITY

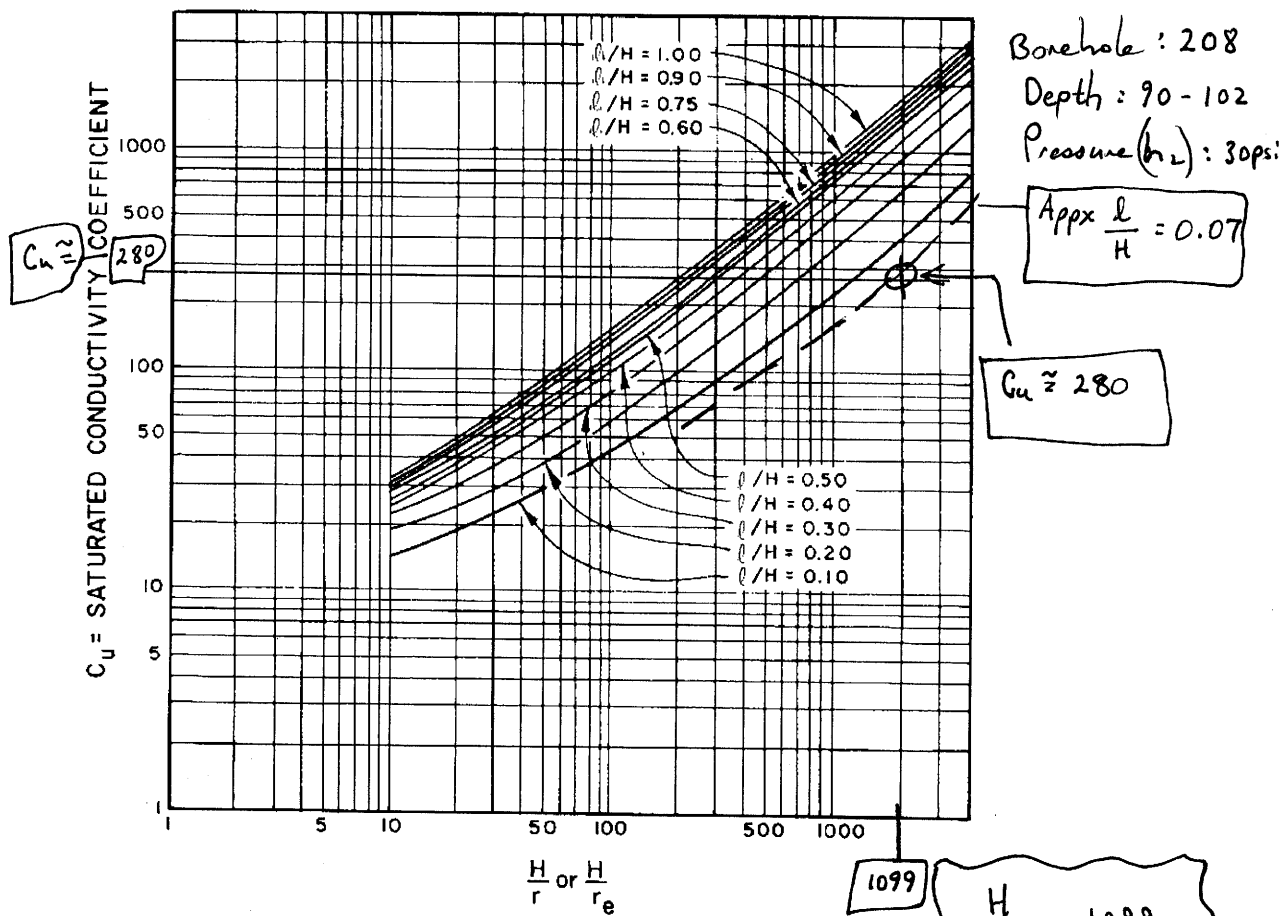

Figure 17-7.—Conductivity coefficients for permeability determination in unsaturated materials with partially penetrating cylindrical test wells.

$$\frac{H}{r} = 1099$$

$$\frac{l}{H} = 0.07$$

Zone 2

Given: U , l , r , h_2 , Q , and L are as given in example 1, $D = 65$ feet, and $h_1 = 72$ feet

If the distance from the gauge to the bottom of the intake pipe is 62 feet, the total L is $(6.2)(0.76) = 4.7$ feet.

$$H = 72 + 57.8 - 4.7 = 125.1 \text{ feet}$$

S

Packer Test Set-up Sheet

For straddle packer tests in Zone I
- Above water table -

JOB NO. Borehole 208

DATE:

JOB NAME: Depth 90-102 ft.

PREPARED: Pressure (h_2) = 30 psi (69.3 ft)

SHEET NO. OF

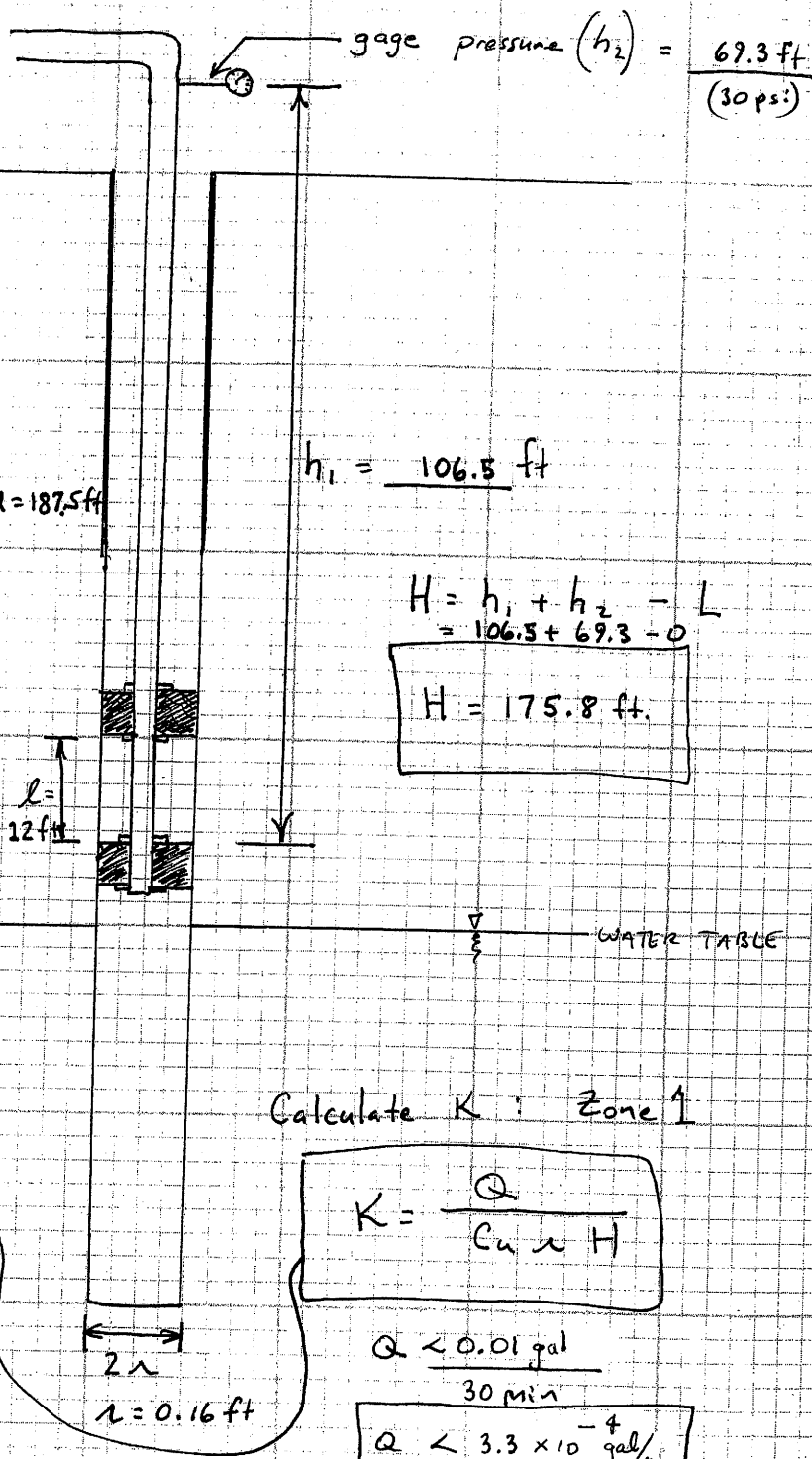

Injector Pipe
Obtain L (head loss coeff.)
 $L = \frac{0.0 \text{ ft/10 ft}}{(\dot{Q} < 4 \text{ gpm})}$
from Pressure - Loss Curve

Obtain C_u
 $C_u \approx 280$
from fig 17.7 USBR

$$\frac{H}{r} = \frac{175.8 \text{ ft}}{0.16 \text{ ft}} = 1099$$

$$\frac{l}{H} = \frac{12 \text{ ft}}{175.8 \text{ ft}} = 0.07$$

$$K = \frac{Q}{C_u r H}$$

$$K < \frac{(3.3 \times 10^{-4} \text{ gal/min})(1440 \text{ min})}{(280)(0.16 \text{ ft})(175.8 \text{ ft})} \left(\frac{\text{ft}^2}{7.48 \text{ gal}} \right)$$

$$K < 8.2 \times 10^{-6} \text{ ft/d}$$

$$K < 2.9 \times 10^{-9} \text{ cm/s}$$

$$H = h_1 + h_2 - L$$

$$= 106.5 + 69.3 - 0$$

$$H = 175.8 \text{ ft.}$$

Calculate K : Zone I

$$K = \frac{Q}{C_u r H}$$

$$Q < \frac{0.01 \text{ gal}}{30 \text{ min}}$$

$$Q < 3.3 \times 10^{-4} \text{ gal/min}$$

S

Packer Test Set-up Sheet

For straddle packer tests in Zone 1
- Above water Table -

JOB NO: Borehole 208

DATE:

JOB NAME: Depth 90-102 ft.

PREPARED: Pressure (h_2) = 46.2 ft (20psi)
REVIEWED: (retest)

SHEET NO. OF

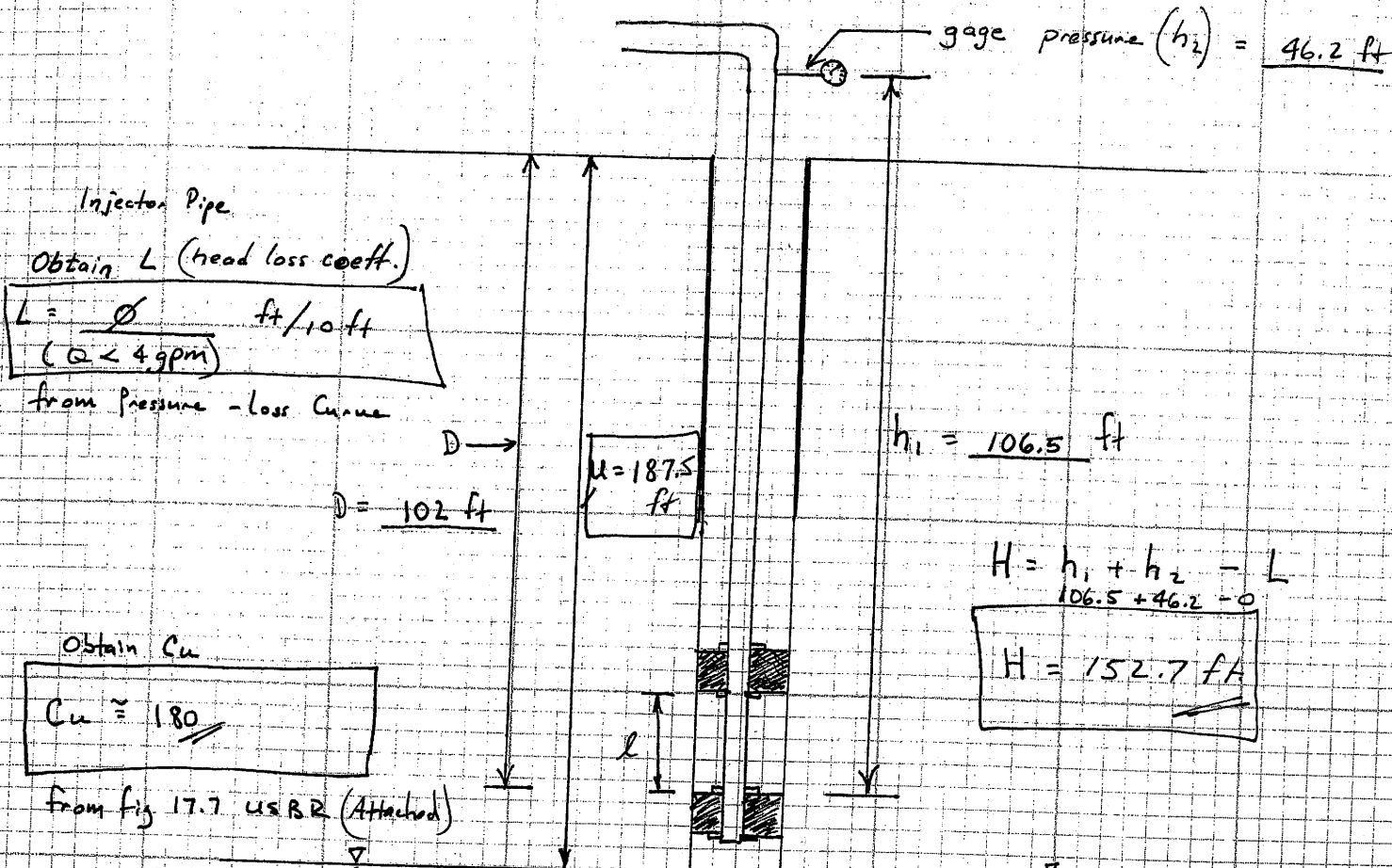

Injector Pipe
Obtain L (head loss coeff.)
 $L = \frac{\phi}{Q} \text{ ft}/10 \text{ ft}$
($Q < 4 \text{ gpm}$)
from Pressure - Loss Curve

$D = 102 \text{ ft}$

$Q = 187.5 \text{ ft}^3/\text{min}$

$h_1 = 106.5 \text{ ft}$

$H = h_1 + h_2 - L$
 $106.5 + 46.2 - 0$
 $H = 152.7 \text{ ft}$

Obtain C_u
 $C_u \approx 180$

from fig 17.7 USBR (Attached)

$\frac{H}{r} = \frac{152.7 \text{ ft}}{0.16 \text{ ft}} = 968.2$

$\frac{l}{H} = \frac{12 \text{ ft}}{152.7 \text{ ft}} = 0.08$

$Q < 0.01 \text{ gal}/20 \text{ min}$
 $Q < 5.0 \times 10^{-4} \text{ gal}/\text{min}$

$K < \frac{(5.0 \times 10^{-4} \text{ gal}/\text{min}) (1440 \text{ min}) (1 \text{ ft}^3)}{(180) (0.16 \text{ ft}) (152.7 \text{ ft})} \left(\frac{1 \text{ ft}^3}{7.48 \text{ gal}} \right)$

Calculate K : Zone 1

$K = \frac{Q}{C_u r H}$

$2r = 3.785''$
 $r = 0.16 \text{ ft}$

$K < 2.2 \times 10^{-5} \text{ ft}/d$
 $K < 7.7 \times 10^{-9} \text{ cm}/s$

S

Packer Test Set-up Sheet

For straddle packer tests in Zone I
- Above water Table -

JOB NO: Borehole: 208 DATE: _____
 JOB NAME: Depth: 90-102 ft
 PREPARED: Pressure (h_2): 23.1 ft REVIEWED: _____
 SHEET NO: Crescent Junction Side

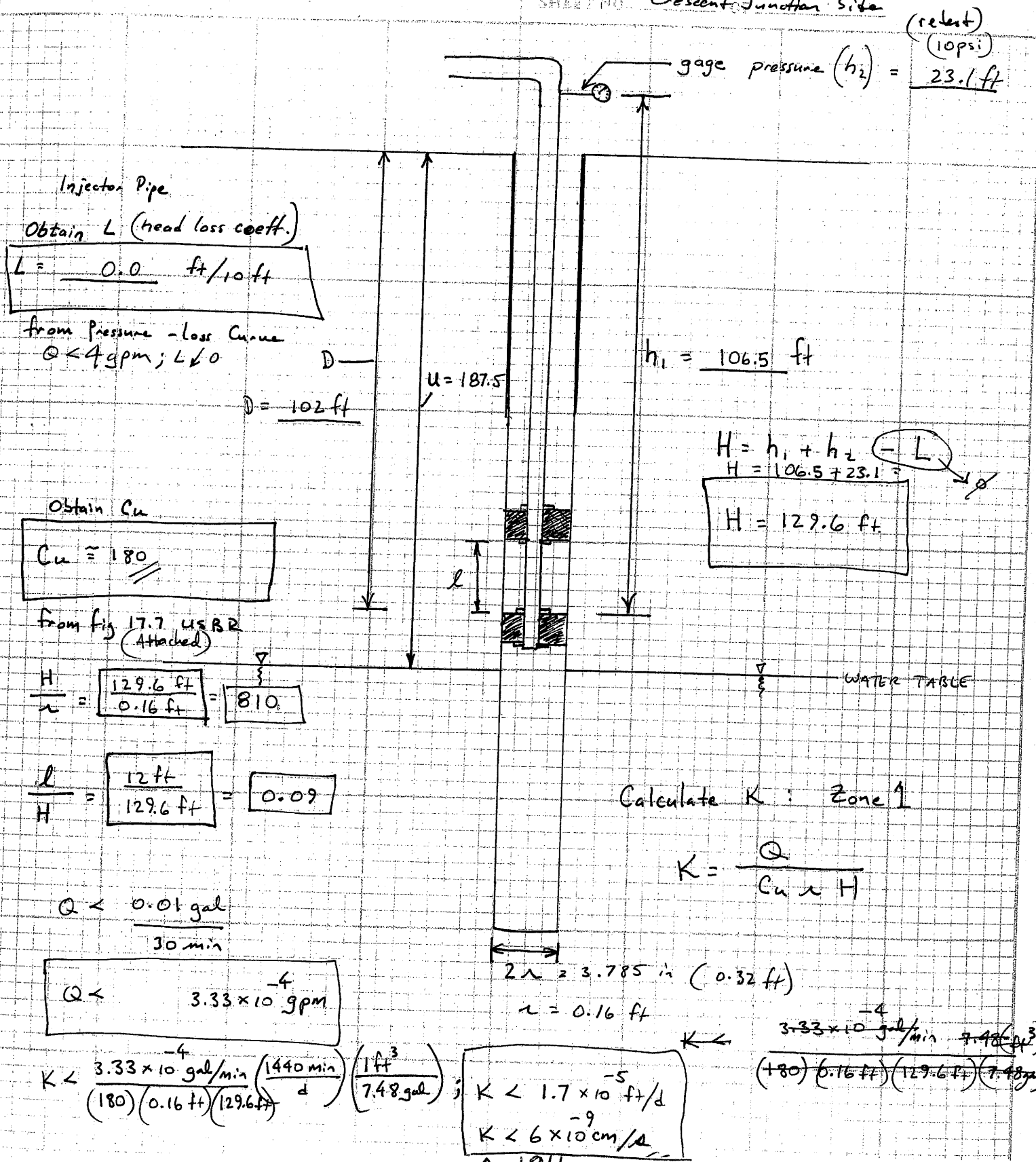

(relect)
(10psi)
23.1 ft

Injector Pipe
Obtain L (head loss coeff.)
L = 0.0 ft/10 ft

from Pressure - Loss Curve
 $Q < 4 \text{ gpm}; L < 0$
D = 102 ft
u = 187.5

gage pressure (h_2) = 23.1 ft

$h_1 = 106.5 \text{ ft}$

$H = h_1 + h_2 - L$
 $H = 106.5 + 23.1$
 $H = 129.6 \text{ ft}$

Obtain C_u
 $C_u \approx 180$

from fig 17.7 USBR (Attached)
 $\frac{H}{r} = \frac{129.6 \text{ ft}}{0.16 \text{ ft}} = 810$

$\frac{l}{H} = \frac{12 \text{ ft}}{129.6 \text{ ft}} = 0.09$

Calculate K: Zone I

$$K = \frac{Q}{C_u r H}$$

$Q < \frac{0.01 \text{ gal}}{30 \text{ min}}$
 $Q < 3.33 \times 10^{-4} \text{ gpm}$

$2r = 3.785 \text{ in (0.32 ft)}$
 $r = 0.16 \text{ ft}$

$K < \frac{3.33 \times 10^{-4} \text{ gal/min} \left(\frac{1440 \text{ min}}{d} \right) \left(\frac{1 \text{ ft}^3}{7.48 \text{ gal}} \right)}{(180)(0.16 \text{ ft})(129.6 \text{ ft})}$
 $K < 1.7 \times 10^{-5} \text{ ft/d}$
 $K < 6 \times 10^{-9} \text{ cm/d}$

$\frac{3.33 \times 10^{-4} \text{ gal/min} \cdot 7.48 \text{ ft}^3}{(180)(0.16 \text{ ft})(129.6 \text{ ft})(7.48 \text{ gal})}$

Stoller

established 1959

Packer-Test Record

Page 1 of 2

Project Name: Mod. Concent Jet characterization Date: 01/15/06

Field Representative: E. Rupp Borehole No. 0208 Total Depth: 300 ft.

Depth to Water (TOC): 187.5 ft. Borehole Cleaned? Yes No Date: 1/15/06

Test Interval (BGL): from 121' to 133' ft. Swivel/Elbow Height (AGL) 4.0 ft.

Conductor Pipe, Type and Size: 1-inch ID Thin Wall Steel Tubing

Time	Gauge Pressure	Flow Meter Reading	Flow Rate
<u>1335</u>	<u>10 psi</u>	<u>39418.85</u>	<u> </u>
<u>1340</u>	<u>10</u>	<u>39418.80</u>	<u>-0.01 gpm</u>
<u>1345</u>	<u>10</u>	<u>39418.80</u>	<u>0</u>
<u>1350</u>	<u>10</u>	<u>39418.80</u>	<u>0</u>
<u>1355</u>	<u>10</u>	<u>39418.80</u>	<u>0</u>
<u>1400</u>	<u>10</u>	<u>39418.80</u>	<u>0</u>
<u>1405</u>	<u>10</u>	<u>39418.80</u>	<u>0</u>
<u>1410</u>	<u>10</u>	<u>39418.80</u>	<u>0</u>
<u>1415</u>	<u>20 psi</u>	<u>39420.05</u>	<u>0.25 gpm</u>
<u>1420</u>	<u>20</u>	<u>39420.10</u>	<u>0.01</u>
<u>1425</u>	<u>20</u>	<u>39420.10</u>	<u>0</u>
<u>1430</u>	<u>20</u>	<u>39420.15</u>	<u>0.01</u>
<u>1435</u>	<u>20</u>	<u>39420.15</u>	<u>0</u>
<u>1440</u>	<u>20</u>	<u>39420.15</u>	<u>0</u>
<u>1445</u>	<u>20</u>	<u>39420.20</u>	<u>0.01 gpm</u>
<u>1450</u>	<u>20</u>	<u>39420.25</u>	<u>0.01</u>
<u>1455</u>	<u>20</u>	<u>39420.25</u>	<u>0</u>
<u>1500</u>	<u>20</u>	<u>39420.25</u>	<u>0</u>
<u>1505</u>	<u>20</u>	<u>39420.25</u>	<u>0 gpm</u>

Stoller

established 1959

Packer-Test Record

Page 2 of 2

Project Name: Moab-Crescent Jet Characterization Date: 01/15/06

Field Representative: R. Rupp Borehole No. 0208 Total Depth: 300'

Depth to Water (TOC): 187.5 ft. Borehole Cleaned? Yes No Date: 01/15/06

Test Interval (BGL): from 121' to 133' ft. Swivel/Elbow Height (AGL) 4.0 ft.

Conductor Pipe, Type and Size: 1-inch ID Thin Wall STEEL Tubing

Time	Gauge Pressure	Flow Meter Reading	Flow Rate
<u>1510</u>	<u>30 psi</u>	<u>39421.20</u>	<u>0.19 gpm</u>
<u>1515</u>	<u>30</u>	<u>39421.40</u>	<u>0.04</u>
<u>1520</u>	<u>30</u>	<u>39421.60</u>	<u>0.04</u>
<u>1525</u>	<u>30</u>	<u>39421.80</u>	<u>0.04</u>
<u>1530</u>	<u>30</u>	<u>39422.00</u>	<u>0.04</u>
<u>1535</u>	<u>30</u>	<u>39422.20</u>	<u>0.04</u>
<u>1540</u>	<u>20 psi</u>	<u>39422.15</u>	<u>-0.01 gpm</u>
<u>1545</u>	<u>20</u>	<u>39422.15</u>	<u>0</u>
<u>1550</u>	<u>20</u>	<u>39422.15</u>	<u>0</u>
<u>1555</u>	<u>20</u>	<u>39422.15</u>	<u>0</u>
<u>1600</u>	<u>20</u>	<u>39422.15</u>	<u>0</u>
<u>1605</u>	<u>20</u>	<u>39422.15</u>	<u>0 gpm</u>
<u>1610</u>	<u>10 psi</u>	<u>39422.00</u>	<u>-0.03 gpm</u>
<u>1615</u>	<u>10</u>	<u>39422.00</u>	<u>0</u>
<u>1620</u>	<u>10</u>	<u>39422.00</u>	<u>0</u>
<u>1625</u>	<u>10</u>	<u>39422.00</u>	<u>0</u>
<u>1630</u>	<u>10</u>	<u>39422.00</u>	<u>0</u>
<u>1635</u>	<u>10</u>	<u>39422.00</u>	<u>0</u>

Stoller

DATE 1-23-06

JOB TITLE Crescent Junction

PREPARED: M. Kautsky

REVIEWED:

SHEET NO. OF

PACKER TEST ANALYSES

BOREHOLE : 208

Depth : 121-133 ft.

Pressure (h_2) : 10 psi (23.1 ft)

Unsaturated Zone Calculation:

Definitions: l = length of test section

$$T_u = U - D + H$$

 U = Thickness of Unsaturated Material D = distance from ground surface to bottom of test section

$$H = h_1 + h_2 - L$$

 L = head loss ; ignore if $Q < 4$ gpm

$$X = \frac{H}{T_u} (100) ; \text{percent unsaturated material}$$

Reference Figure 17-6 U.S. Bureau of Rec. Earth Manual

$$l = 12 \text{ ft}$$

$$T_u = U - D + H = 187.5 \text{ ft} - 133 \text{ ft} + 160.1 \text{ ft} = 205.6 \text{ ft}$$

$$\frac{T_u}{l} = \frac{205.6 \text{ ft}}{12 \text{ ft}} = \boxed{17.1}$$

$$H = h_1 + h_2 - L = 137 \text{ ft} + 23.1 \text{ ft} - 0 = 160.1 \text{ ft}$$

$$X = \frac{H}{T_u} (100) = \frac{160.1 \text{ ft}}{205.6 \text{ ft}} (100) = \boxed{78}$$

$$h_1 = 133 \text{ ft} + 4 \text{ ft} = 137 \text{ ft.}$$

WATER TESTING FOR PERMEABILITY

- Effective head, the difference in feet (m) between the elevation of the free water surface in the pipe and the elevation of the gauge plus the applied pressure. If a pressure transducer is used, the effective head in the test section is the difference in pressure before water is pumped into the test section and the pressure readings made during the test.

The following examples show some typical calculations using Methods 1 and 2 in the different zones shown in figure 17-5. Figure 17-6 shows the location of the zone 1 lower boundary for use in unsaturated materials.

Pressure permeability tests examples using Methods 1 and 2:

Borehole : 208
 Depth : 121-133 ft.
 Pressure (h_2) : 10 psi

23.1 ft

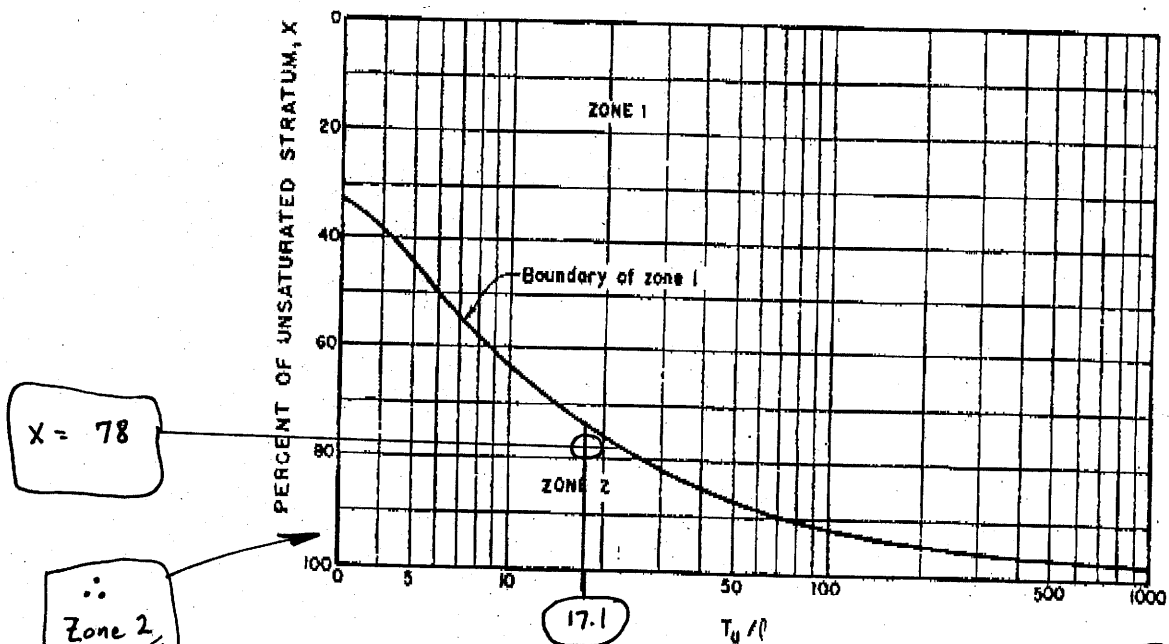

Figure 17-6.—Location of zone 1 lower boundary for use in unsaturated materials.

$\frac{T_u}{l} = 17.1$

 $X = 78$

FIELD MANUAL

$$T_u = 75 - 65 + 125.1 = 135.1 \text{ feet}$$

$$X = \frac{125.1}{135.1} (100) = 92.6\% \quad \text{also} \quad \frac{T_u}{l} = \frac{135.1}{10} = 13.5$$

The test section is located in zone 2 (figure 17-6). To determine the saturated conductivity coefficient, C_s , from figure 17-8:

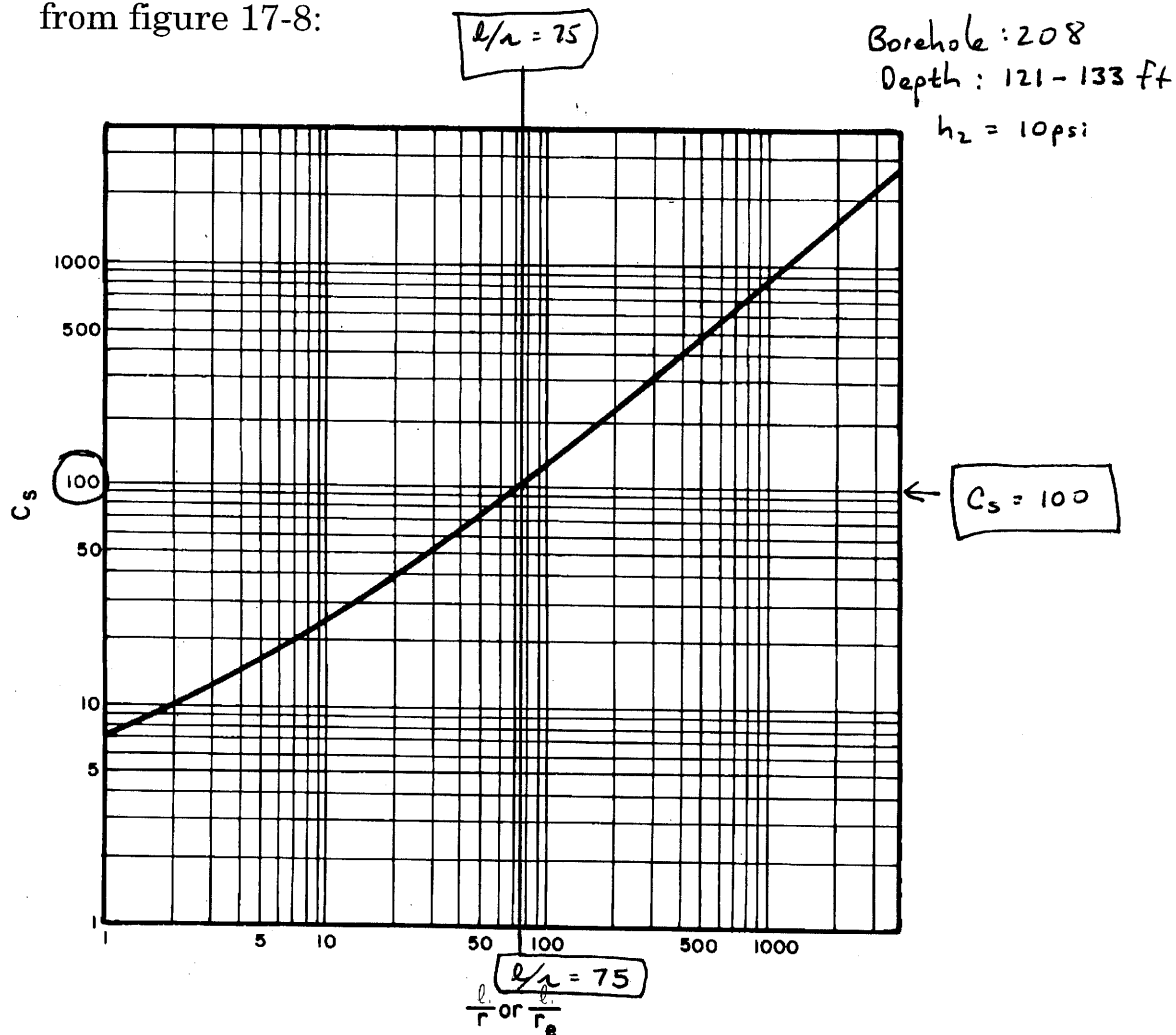

Figure 17-8.—Conductivity coefficients for semispherical flow in saturated materials through partially penetrating cylindrical test wells.

Stoller

PACKER TEST SET-UP SHEET
ZONE 2 / METHOD 2

JOB NO.: _____ DATE: 1-24-06

JOB NAME: Crescent Junction Site

PREPARED: M. Kautsky

REVIEWED: _____

SHEET NO.: _____ OF _____

Borehole 208
Depth 121-133 ft
Pressure (h_2) 110 psi (23.1 ft)

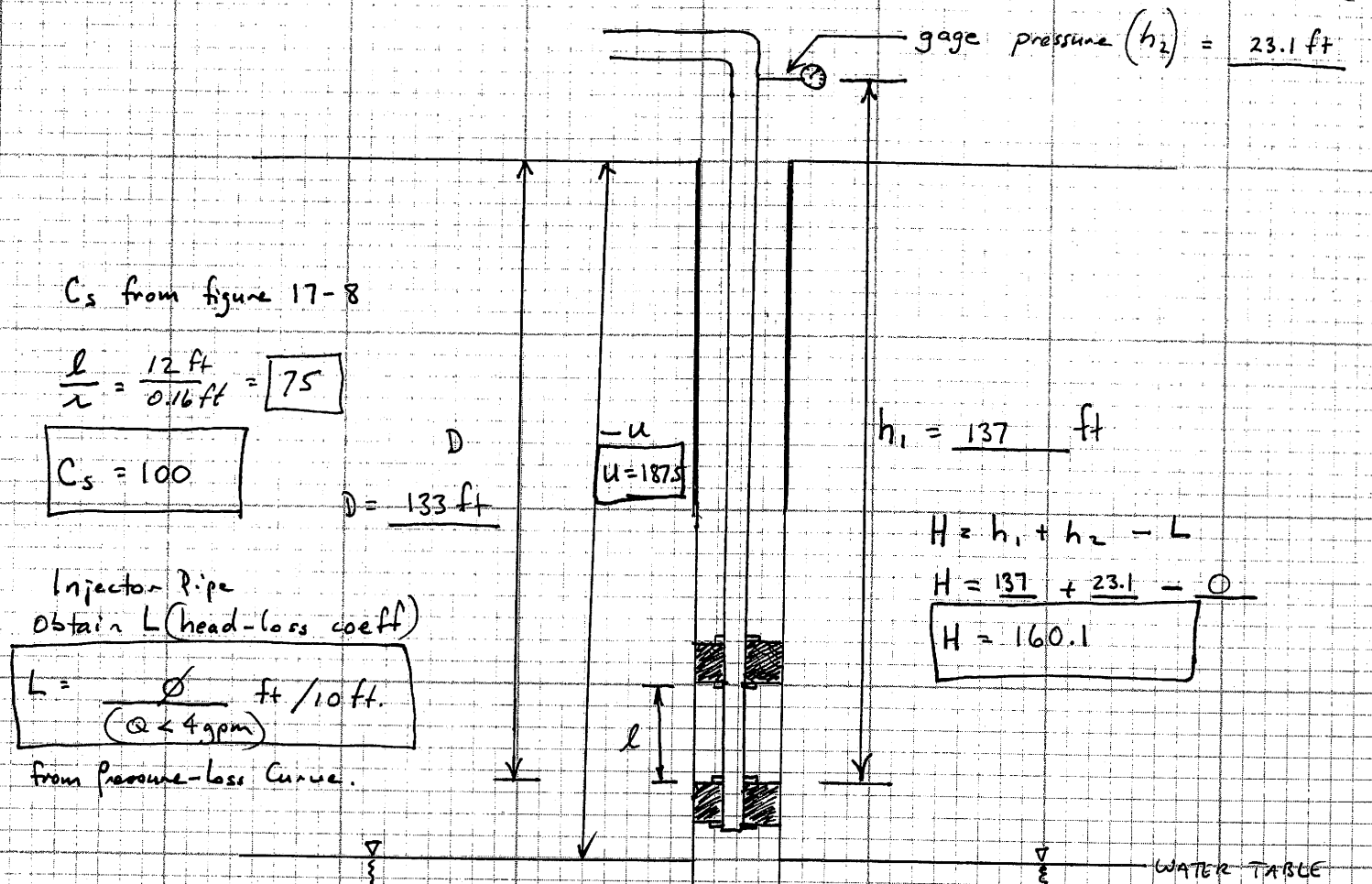

C_s from figure 17-8

$$\frac{l}{r} = \frac{12 \text{ ft}}{0.16 \text{ ft}} = 75$$

$$C_s = 100$$

$$D = 133 \text{ ft}$$

$$u = 187.5$$

$$h_1 = 137 \text{ ft}$$

$$H = h_1 + h_2 - L$$

$$H = 137 + 23.1 - 0$$

$$H = 160.1$$

Injector Pipe
Obtain L (head-loss coeff)

$$L = \frac{\phi}{Q} \text{ ft/10 ft.}$$

($Q < 4 \text{ gpm}$)

from Pressure-loss Curve.

Obtain T_u :

$$T_u = u - D + H$$

$$T_u = 187.5 - 133.0 + 160.1$$

$$T_u = 205.6 \text{ ft}$$

$$Q < \frac{0.01 \text{ gal}}{30 \text{ min}}$$

$$Q < 3.3 \times 10^{-4} \text{ gal/min}$$

CALCULATE K : ZONE 2

$$K = \frac{2Q}{(C_s r)(T_u + H - l)}$$

$$K < \frac{2(3.3 \times 10^{-4} \text{ gal/min})}{100(0.16)(205.6 + 160.1 - 12)}$$

$$K < 1.2 \times 10^{-7} \text{ gal/min/ft}^2$$

$$K < \left(\frac{1.2 \times 10^{-7} \text{ gal}}{\text{min} \cdot \text{ft}^2} \right) \left(\frac{1 \text{ ft}^3}{7.48 \text{ gal}} \right) \left(\frac{1440 \text{ min}}{\text{d}} \right) = 2.27 \times 10^{-5} \text{ ft/d}$$

$$K < 8.0 \times 10^{-9} \text{ cm/a}$$

Stoller

DATE: 1-23-06

JOB NAME: Crescent Junction

PREPARED: M. Kautsky

REVIEWED:

SHEET NO. OF

PACKER TEST ANALYSES

BOREHOLE: 208

Depth: 121-133

Unsaturated Zone Calculation:

Pressure (h_2): 20 psi (46.2 ft)

Definitions:

 L = length of test section $T_u = U - D + H$ U = Thickness of Unsaturated Material D = distance from ground surface to bottom of test section $H = h_1 + h_2 - L$ L = head loss; ignore if $Q < 4$ gpm $X = \frac{H}{T_u} (100)$; percent unsaturated material

Reference Figure 17-6 U.S. Bureau of Rec. Earth Manual

$$L = 12 \text{ ft}$$

$$T_u = U - D + H = 187.5 \text{ ft} - 133 \text{ ft} + 183.2 \text{ ft} = 237.7 \text{ ft}$$

$$\frac{T_u}{L} = \frac{237.7 \text{ ft}}{12 \text{ ft}} = \boxed{19.8}$$

$$H = h_1 + h_2 - L = 137 \text{ ft} + 46.2 \text{ ft} - 0 = 183.2 \text{ ft}$$

$$X = \frac{H}{T_u} (100) = \frac{183.2 \text{ ft}}{237.7 \text{ ft}} = 0.77 (100) = \boxed{77}$$

$$h_1 = 133 \text{ ft} + 4 \text{ ft} = 137 \text{ ft}$$

WATER TESTING FOR PERMEABILITY

- Effective head, the difference in feet (m) between the elevation of the free water surface in the pipe and the elevation of the gauge plus the applied pressure. If a pressure transducer is used, the effective head in the test section is the difference in pressure before water is pumped into the test section and the pressure readings made during the test.

The following examples show some typical calculations using Methods 1 and 2 in the different zones shown in figure 17-5. Figure 17-6 shows the location of the zone 1 lower boundary for use in unsaturated materials.

Pressure permeability tests examples using Methods 1 and 2:

Borehole : 208
 Depth : 121-133
 Pressure (h_2) : 46.2 ft
 (20 psi)

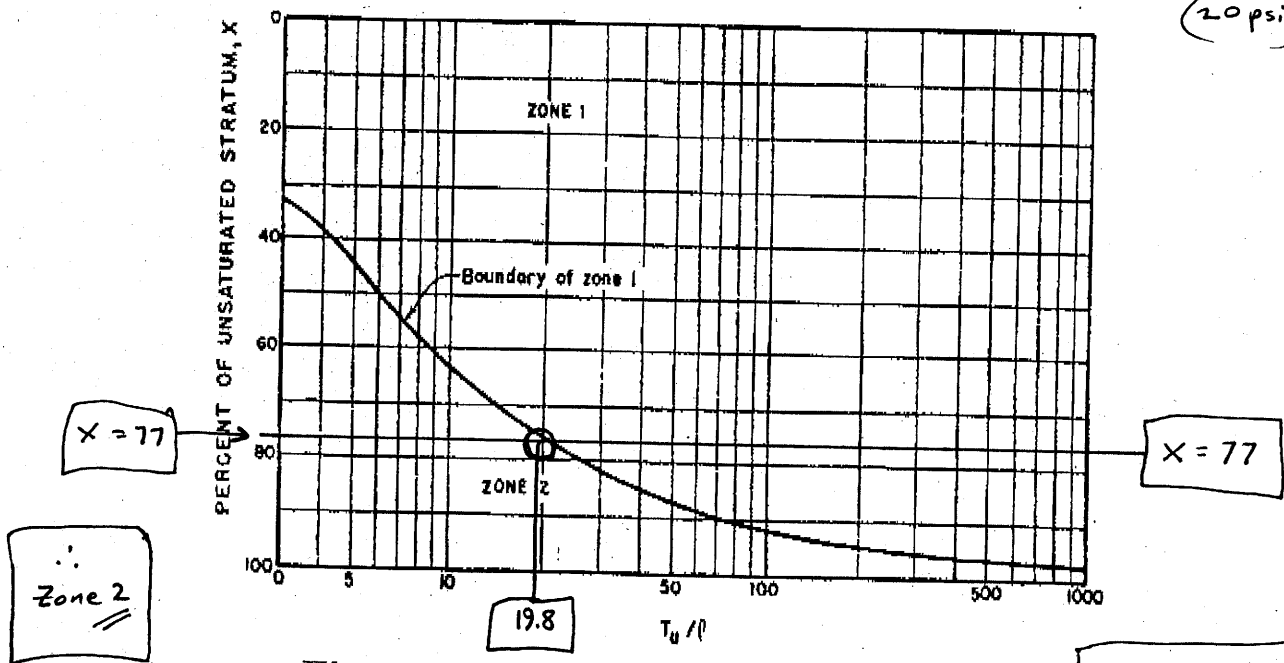

Figure 17-6.—Location of zone 1 lower boundary for use in unsaturated materials.

$$\frac{T_u}{l} = 19.8$$

$$X = 77$$

Stoller

PACKER TEST SET-UP SHEET

ZONE 2 / METHOD 2

JOB NO.: _____ DATE: 1-24-06

JOB NAME: Crescent Junction site

PREPARED: M. Kautsky

REVIEWED:

SHEET NO.: _____ OF _____

Borehole 208
Depth 121-133
pressure: 20 psi

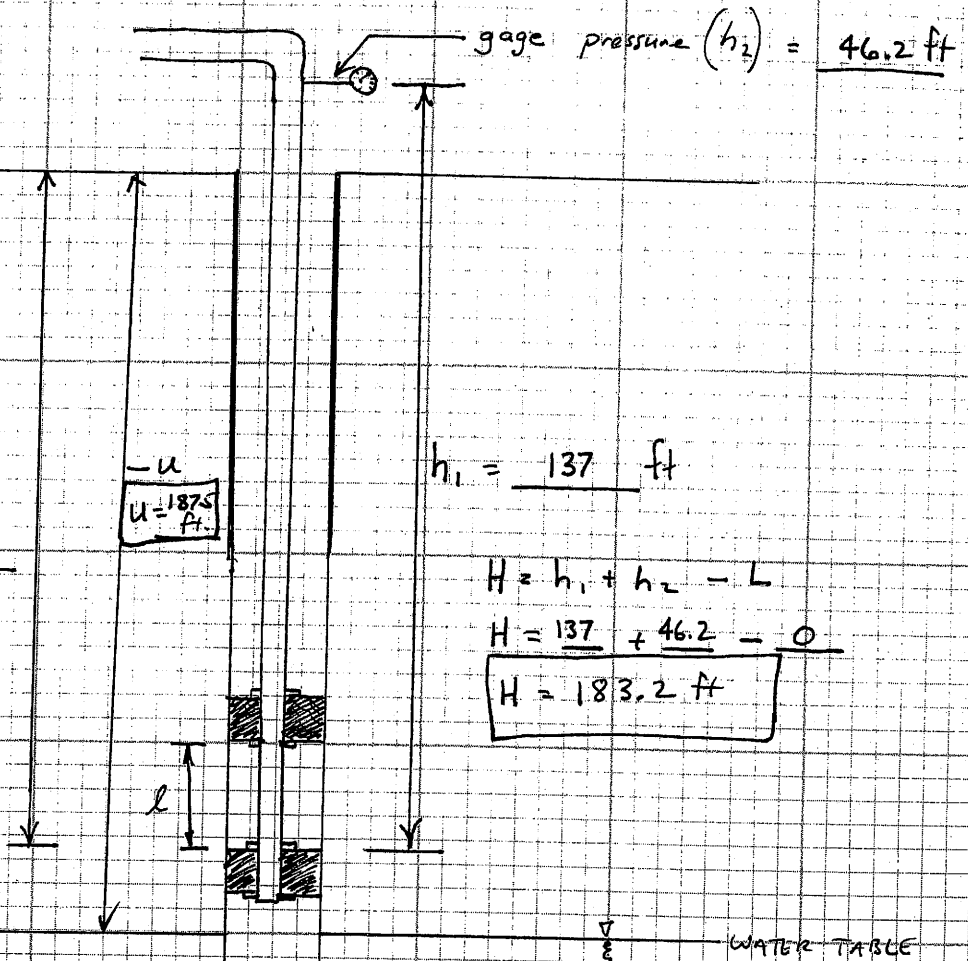

C_s from figure 17-8

$$\frac{l}{r} = \frac{12 \text{ ft}}{0.16 \text{ ft}} = 75$$

$$C_s = 100$$

$$D = 133 \text{ ft}$$

$$h_1 = 137 \text{ ft}$$

$$H = h_1 + h_2 - L$$

$$H = 137 + 46.2 - 0$$

$$H = 183.2 \text{ ft}$$

Injector Pipe
Obtain L (head-loss coeff)

$$L = \frac{0.0 \text{ ft}}{10 \text{ ft}} \quad (Q < 4 \text{ gpm})$$

from Pressure-loss Curve.

Obtain T_u :

$$T_u = U - D + H$$

$$T_u = 187.5 - 133 + 183.2$$

$$T_u = 237.7$$

$$Q < \frac{0.01 \text{ gal}}{15 \text{ min}}$$

$$Q < 6.7 \times 10^{-4} \text{ gal/min}$$

CALCULATE K : ZONE 2

$$K = \frac{2Q}{(C_s L)(T_u + H - l)}$$

$$K < \frac{2(6.7 \times 10^{-4} \text{ gal/min})}{(100)(0.16 \text{ ft})(237.7 \text{ ft} + 183.2 \text{ ft} - 12 \text{ ft})} \left(\frac{1 \text{ ft}^3}{7.48 \text{ gal}} \right) \left(\frac{1440 \text{ min}}{d} \right)$$

$$K < 3.9 \times 10^{-5} \text{ ft/d}$$

$$K < 1.4 \times 10^{-8} \text{ cm/s}$$

Stoller

DATE 1-23-06

JOB NAME Crescent Junction

PREPARED BY M. Kautsky

REVIEWED:

SHEET NO. OF

PACKER TEST ANALYSES

BOREHOLE : 208

Depth : 121-133 ft

Pressure (h_2) : 30 psi (69.3 ft)

Unsaturated Zone Calculation:

Definitions:

 l = length of test section

$$T_u = u - D + H$$

 u = Thickness of Unsaturated Material D = distance from ground surface to bottom of test section

$$H = h_1 + h_2 - L$$

 L = head loss ; ignore if $Q < 4 \text{ gpm}$

$$X = \frac{H}{T_u} (100) ; \text{percent unsaturated material}$$

Reference Figure 17-6 U.S. Bureau of Rec. Earth Manual

$$l = 12 \text{ ft}$$

$$T_u = u - D + H = 187.5 \text{ ft} - 133 \text{ ft} + 206.3 \text{ ft} = 260.8 \text{ ft}$$

$$\frac{T_u}{l} = \frac{260.8 \text{ ft}}{12 \text{ ft}} = \boxed{21.7}$$

$$H = h_1 + h_2 - L = 137 \text{ ft} + 69.3 \text{ ft} - 0 \text{ ft} = 206.3 \text{ ft}$$

$$X = \frac{H}{T_u} (100) = \frac{206.3 \text{ ft}}{260.8 \text{ ft}} (100) = \boxed{79}$$

$$h_1 = 133 \text{ ft} + 4 \text{ ft} = 137 \text{ ft}$$

WATER TESTING FOR PERMEABILITY

- Effective head, the difference in feet (m) between the elevation of the free water surface in the pipe and the elevation of the gauge plus the applied pressure. If a pressure transducer is used, the effective head in the test section is the difference in pressure before water is pumped into the test section and the pressure readings made during the test.

The following examples show some typical calculations using Methods 1 and 2 in the different zones shown in figure 17-5. Figure 17-6 shows the location of the zone 1 lower boundary for use in unsaturated materials.

Pressure permeability tests examples using Methods 1 and 2:

Borehole : 208
 Depth : 121-133 ft
 Pressure (h_2) : 30 psi (69.3 ft)

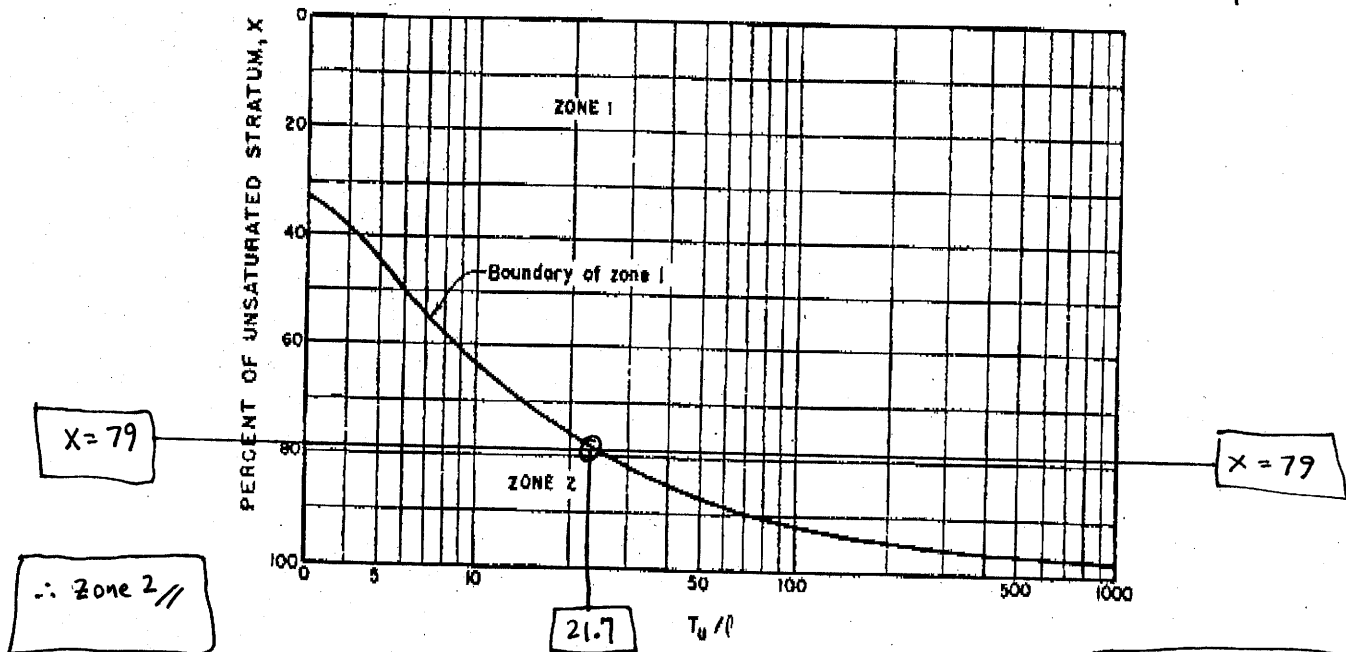

Figure 17-6.—Location of zone 1 lower boundary for use in unsaturated materials.

$$\frac{T_u}{l} = 21.7$$

$$X = 79$$

Stoller

PACKER TEST SET-UP SHEET

ZONE 2 / METHOD 2

JOB NO.: _____ DATE: 1-24-06

JOB NAME: Crescent Junction Site

PREPARED: M. Kautsky

REVIEWED:

Borehole: 208

Depth: 121-133

pressure: 30 psi

SHEET NO.: _____ OF _____

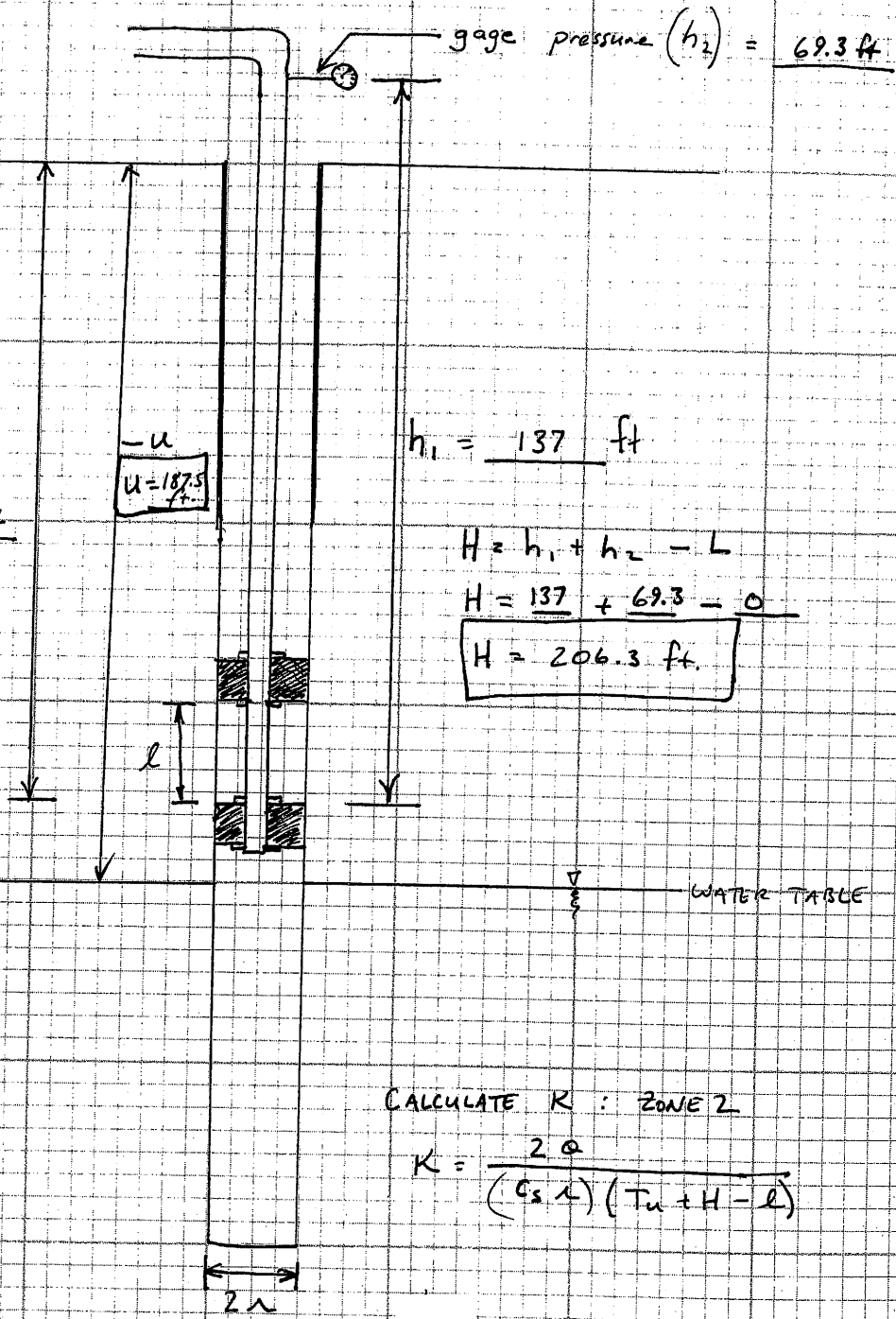

C_s from figure 17-8

$$\frac{l}{r} = \frac{12 \text{ ft}}{0.16 \text{ ft}} = 75$$

$$C_s = 100$$

$$D = 133 \text{ ft}$$

$$h_1 = 137 \text{ ft}$$

$$H = h_1 + h_2 - L$$

$$H = 137 + 69.3 - 0$$

$$H = 206.3 \text{ ft}$$

Injector Pipe
Obtain L (head-loss coeff)

$$L = \frac{0}{Q < 4 \text{ gpm}} \text{ ft/10 ft}$$

from Pressure-loss Curve.

Obtain T_u :

$$T_u = u - D + H$$

$$T_u = 187.5 - 133 + 206.3$$

$$T_u = 260.8 \text{ ft}$$

CALCULATE K : ZONE 2

$$K = \frac{2Q}{(C_s L)(T_u + H - L)}$$

$$Q = 0.04 \text{ gpm}$$

(from data sheet)

$$K = \frac{2(0.04 \text{ gal/min})}{(100)(0.16 \text{ ft})(260.8 \text{ ft} + 206.3 \text{ ft} - 12 \text{ ft})} \left(\frac{1 \text{ ft}^3}{7.48 \text{ gal}} \right) \left(\frac{1440 \text{ min}}{d} \right)$$

$$K = 2.1 \times 10^{-3} \text{ ft/d}$$

$$K = 7.5 \times 10^{-7} \text{ cm/a}$$

Stoller

PACKER TEST SET-UP SHEET
ZONE 2 / METHOD 2

JOB NO.: _____ DATE: 1-24-06

JOB NAME: Crescent Junction site

PREPARED: M. Kautsky

REVIEWED: _____

SHEET NO.: _____ OF _____

Borehole 208
Depth 121-133
pressure: 20 psi
(Ratex)

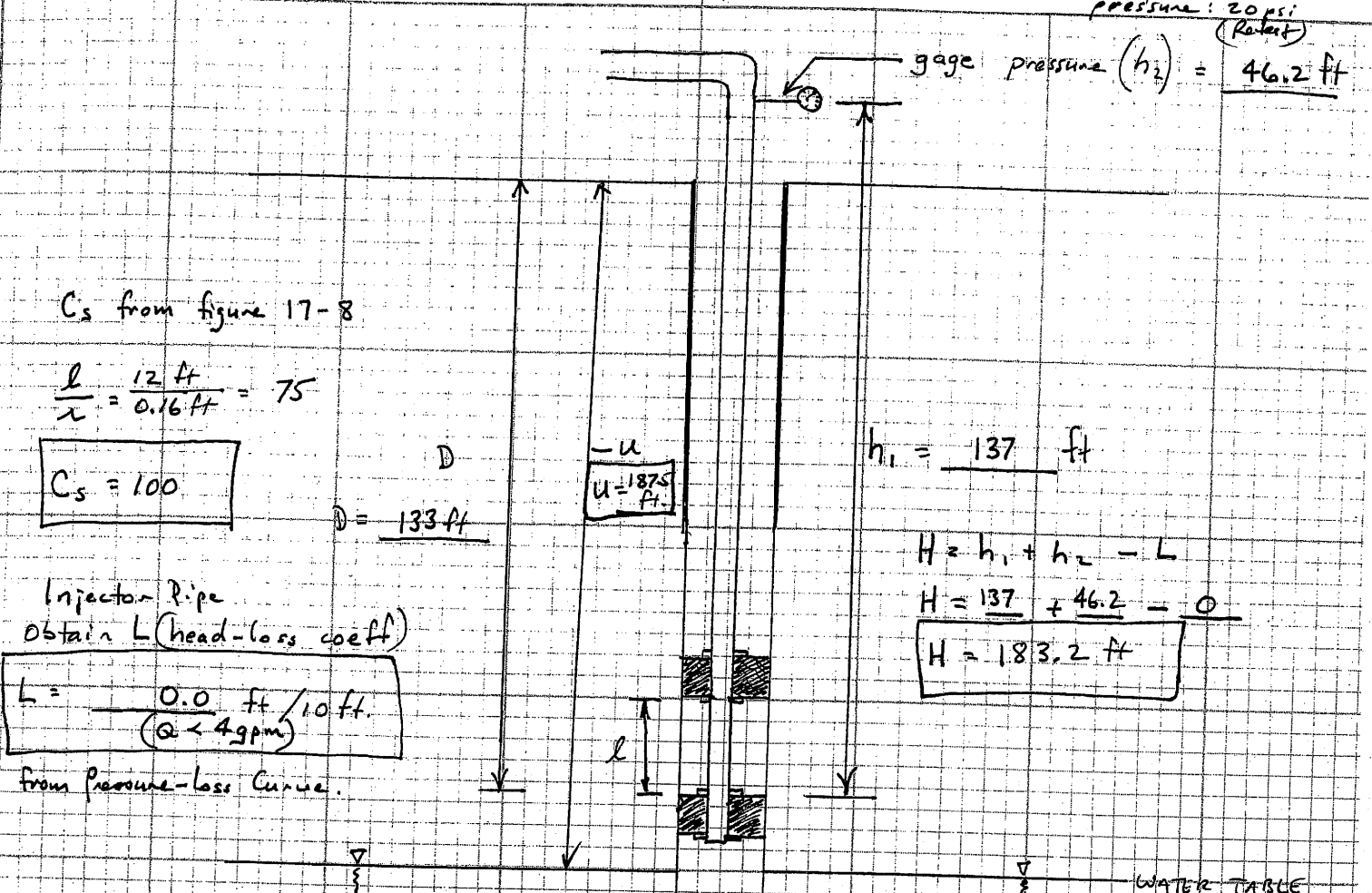

C_s from figure 17-8

$$\frac{l}{r} = \frac{12 \text{ ft}}{0.16 \text{ ft}} = 75$$

$$C_s = 100$$

$$D = 133 \text{ ft}$$

$$u = 187.5 \text{ ft}$$

$$h_1 = 137 \text{ ft}$$

$$H = h_1 + h_2 - L$$

$$H = 137 + 46.2 - 0$$

$$H = 183.2 \text{ ft}$$

Injector Pipe
Obtain L (head-loss coeff)

$$L = \frac{0.0 \text{ ft}/10 \text{ ft}}{(Q < 4 \text{ gpm})}$$

from Pressure-loss Curve.

Obtain T_u :

$$T_u = u - D + H$$

$$T_u = 187.5 - 133 + 183.2$$

$$T_u = 237.7$$

$$Q < \frac{0.01 \text{ gal}}{15 \text{ min}}$$

$$Q < 6.7 \times 10^{-4} \text{ gal/min}$$

CALCULATE K: ZONE 2

$$K = \frac{2Q}{(C_s r) (T_u + H - l)}$$

$$K < \frac{2 (6.7 \times 10^{-4} \text{ gal/min})}{(100)(0.16 \text{ ft}) (237.7 \text{ ft} + 183.2 \text{ ft} - 12 \text{ ft})} \left(\frac{1 \text{ ft}^3}{7.48 \text{ gal}} \right) \left(\frac{1.48 \text{ min}}{d} \right)$$

$$K < 3.9 \times 10^{-5} \text{ ft/d}$$

$$K < 1.4 \times 10^{-8} \text{ cm/s}$$

Stoller

PACKER TEST SET-UP SHEET

ZONE 2 / METHOD 2

JOB NO.: _____ DATE: 1-24-06

JOB NAME: Crescent Junction Site

PREPARED: M. Kautsky REVIEWED: _____

SHEET NO.: _____ OF _____
 Borehole 208
 Depth 121-133 ft
 Pressure (h_2): 10 psi (23.1 ft)
 (Re-test)

gage pressure (h_2) = 23.1 ft

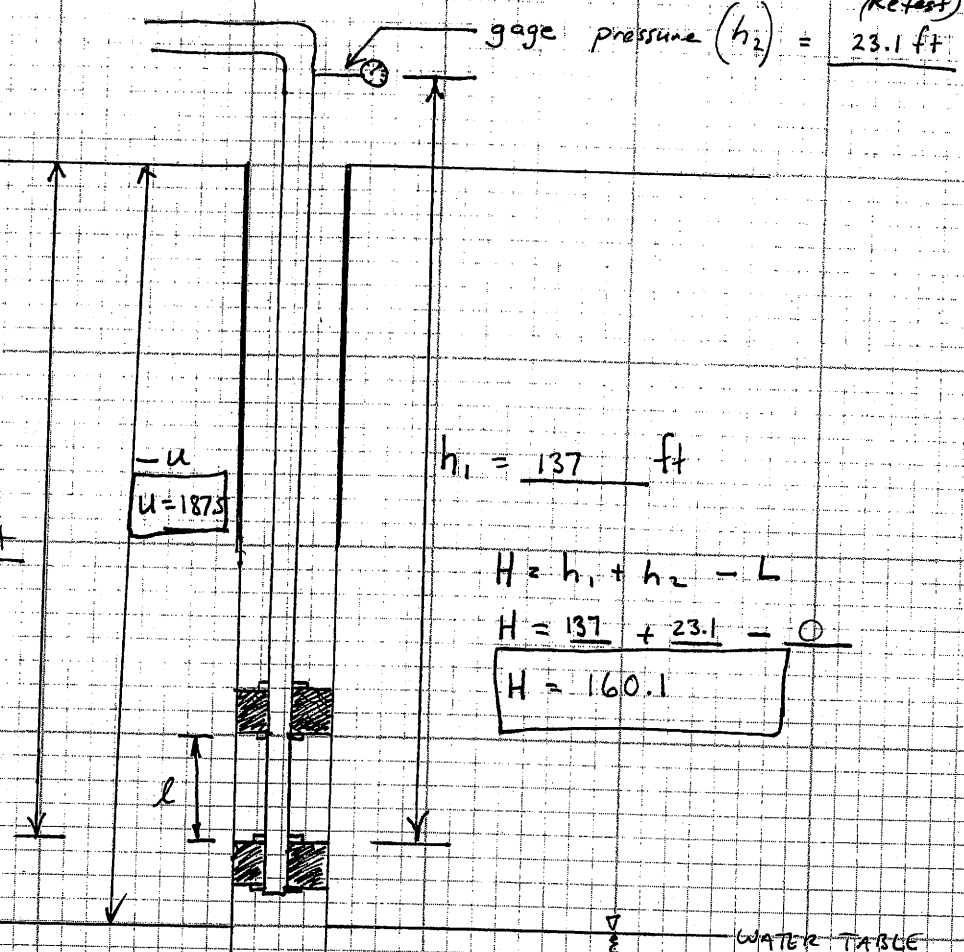

C_s from figure 17-8

$$\frac{l}{r} = \frac{12 \text{ ft}}{0.16 \text{ ft}} = 75$$

$$C_s = 100$$

$$D = 133 \text{ ft}$$

$$u = 187.5$$

$$h_1 = 137 \text{ ft}$$

$$H = h_1 + h_2 - L$$

$$H = 137 + 23.1 - 0$$

$$H = 160.1$$

Injector Pipe
 Obtain L (head-loss coeff)

$$L = \frac{\phi}{Q} \text{ ft/10 ft.}$$

(@ 4 gpm)

from Pressure-loss Curve.

Obtain T_u :

$$T_u = u - D + H$$

$$T_u = 187.5 - 133.0 + 160.1$$

$$T_u = 205.6 \text{ ft}$$

$$Q = \frac{0.01 \text{ gal}}{30 \text{ min}}$$

$$Q < 3.3 \times 10^{-4} \text{ gal/min}$$

CALCULATE K : ZONE 2

$$K = \frac{2Q}{(C_s r)(T_u + H - l)}$$

$$K < \frac{2(3.3 \times 10^{-4} \text{ gal/min})}{100(0.16)(205.6 + 160.1 - 12)}$$

$$K < 1.2 \times 10^{-7} \text{ gal/min/ft}^2$$

$$K < \left(\frac{1.2 \times 10^{-7} \text{ gal}}{\text{min} \cdot \text{ft}^2} \right) \left(\frac{1 \text{ ft}^3}{7.48 \text{ gal}} \right) \left(\frac{1440 \text{ min}}{\text{d}} \right) = 2.27 \times 10^{-5} \text{ ft/d}$$

$$K < 8.0 \times 10^{-9} \text{ cm/s}$$

Stoller

established 1959

Packer-Test Record

Page 1 of 2

Project Name: Moab - Crescent Jet characterization Date: 01/15/06

Field Representative: R. Rupp Borehole No. #0208 Total Depth: 380'

Depth to Water (TOC): 187.5 ft. Borehole Cleaned? Yes No Date: 1/15/06

Test Interval (BGL): from 282' to 294' ft. Swivel/Elbow Height (AGL) 3.0 ft.

Conductor Pipe, Type and Size: 1-inch ID Thin WALL STEEL TUBING

Time	Gauge Pressure	Flow Meter Reading	Flow Rate
<u>0935</u>	<u>5 psi</u>	<u>39405.45</u>	
<u>0940</u>	<u>5 psi</u>	<u>39405.60</u>	<u>0.03 gpm</u>
<u>0945</u>	<u>5</u>	<u>39405.75</u>	<u>0.03</u>
<u>0950</u>	<u>5</u>	<u>39405.95</u>	<u>0.04</u>
<u>0955</u>	<u>5</u>	<u>39406.20</u>	<u>0.05</u>
<u>1000</u>	<u>5</u>	<u>39406.40</u>	<u>0.04</u>
<u>1005</u>	<u>5</u>	<u>39406.60</u>	<u>0.04</u>
<u>1010</u>	<u>5</u>	<u>39406.75</u>	<u>0.03</u>
<u>1015</u>	<u>5</u>	<u>39406.90</u>	<u>0.03</u>
<u>1020</u>	<u>5</u>	<u>39407.05</u>	<u>0.03 gpm</u>
<u>1025</u>	<u>10 psi</u>	<u>39407.35</u>	<u>0.06</u>
<u>1030</u>	<u>10</u>	<u>39407.55</u>	<u>0.04</u>
<u>1035</u>	<u>10</u>	<u>39407.75</u>	<u>0.04</u>
<u>1040</u>	<u>10</u>	<u>39407.90</u>	<u>0.03</u>
<u>1045</u>	<u>10</u>	<u>39408.10</u>	<u>0.04</u>
<u>1050</u>	<u>10</u>	<u>39408.25</u>	<u>0.03</u>
<u>1055</u>	<u>10</u>	<u>39408.40</u>	<u>0.03</u>
<u>1100</u>	<u>10</u>	<u>39408.55</u>	<u>0.03 gpm</u>

Stoller

established 1959

Packer-Test Record

Page 2 of 2

Project Name: Morla - Crescent Jet Characterization Date: 01/15/06

Field Representative: R. Rupp Borehole No. #0208 Total Depth: 300 ft.

Depth to Water (TOC): 187.5 ft. Borehole Cleaned? Yes No Date: 01/15/06

Test Interval (BGL): from 282' to 294 ft. Swivel/Elbow Height (AGL) 3.0 ft.

Conductor Pipe, Type and Size: 1-inch ID thin wall steel tubing

Time	Gauge Pressure	Flow Meter Reading	Flow Rate
<u>1105</u>	<u>20 psi</u>	<u>39408.80</u>	<u>0.05 gpm</u>
<u>1110</u>	<u>20</u>	<u>39408.80</u>	<u>0</u>
<u>1115</u>	<u>20</u>	<u>39408.80</u>	<u>0</u>
<u>1120</u>	<u>20</u>	<u>39408.80</u>	<u>0</u>
<u>1125</u>	<u>20</u>	<u>39408.80</u>	<u>0</u>
<u>1130</u>	<u>20</u>	<u>39408.80</u>	<u>0</u>
<u>1135</u>	<u>20</u>	<u>39408.80</u>	<u>0</u> <u>gpm</u>
<u>1140</u>	<u>10 psi</u>	<u>39408.80</u>	<u>0</u>
<u>1145</u>	<u>10</u>	<u>39408.80</u>	<u>0</u>
<u>1150</u>	<u>10</u>	<u>39408.80</u>	<u>0</u>
<u>1155</u>	<u>10</u>	<u>39408.80</u>	<u>0</u>
<u>1200</u>	<u>10</u>	<u>39408.80</u>	<u>0</u>
<u>1205</u>	<u>10</u>	<u>39408.80</u>	<u>0</u>
<u>1210</u>	<u>10</u>	<u>39408.80</u>	<u>0</u>
<u>1215</u>	<u>10</u>	<u>39408.80</u>	<u>0</u> <u>gpm</u>
<u>1220</u>	<u>5 psi</u>	<u>39408.85</u>	<u>0.01 gpm</u>
<u>1225</u>	<u>5</u>	<u>39408.95</u>	<u>0.02</u>
<u>1230</u>	<u>5</u>	<u>39409.05</u>	<u>0.02</u>
<u>1235</u>	<u>5</u>	<u>39409.15</u>	<u>0.02</u>
<u>1240</u>	<u>5</u>	<u>39409.25</u>	<u>0.02</u>
<u>1245</u>	<u>5</u>	<u>39409.30</u>	<u>0.01</u>
<u>1250</u>	<u>5</u>	<u>39409.35</u>	<u>0.01</u>

FIELD MANUAL

1-25-06
 Borehole 208
 Depth 282-294
 All pressures (5, 10, 20 ps)

$$T_u = 75 - 65 + 125.1 = 135.1 \text{ feet}$$

$$X = \frac{125.1}{135.1} (100) = 92.6\% \text{ also } \frac{T_u}{l} = \frac{135.1}{10} = 13.5$$

The test section is located in zone 2 (figure 17-6). To determine the saturated conductivity coefficient, C_s , from figure 17-8:

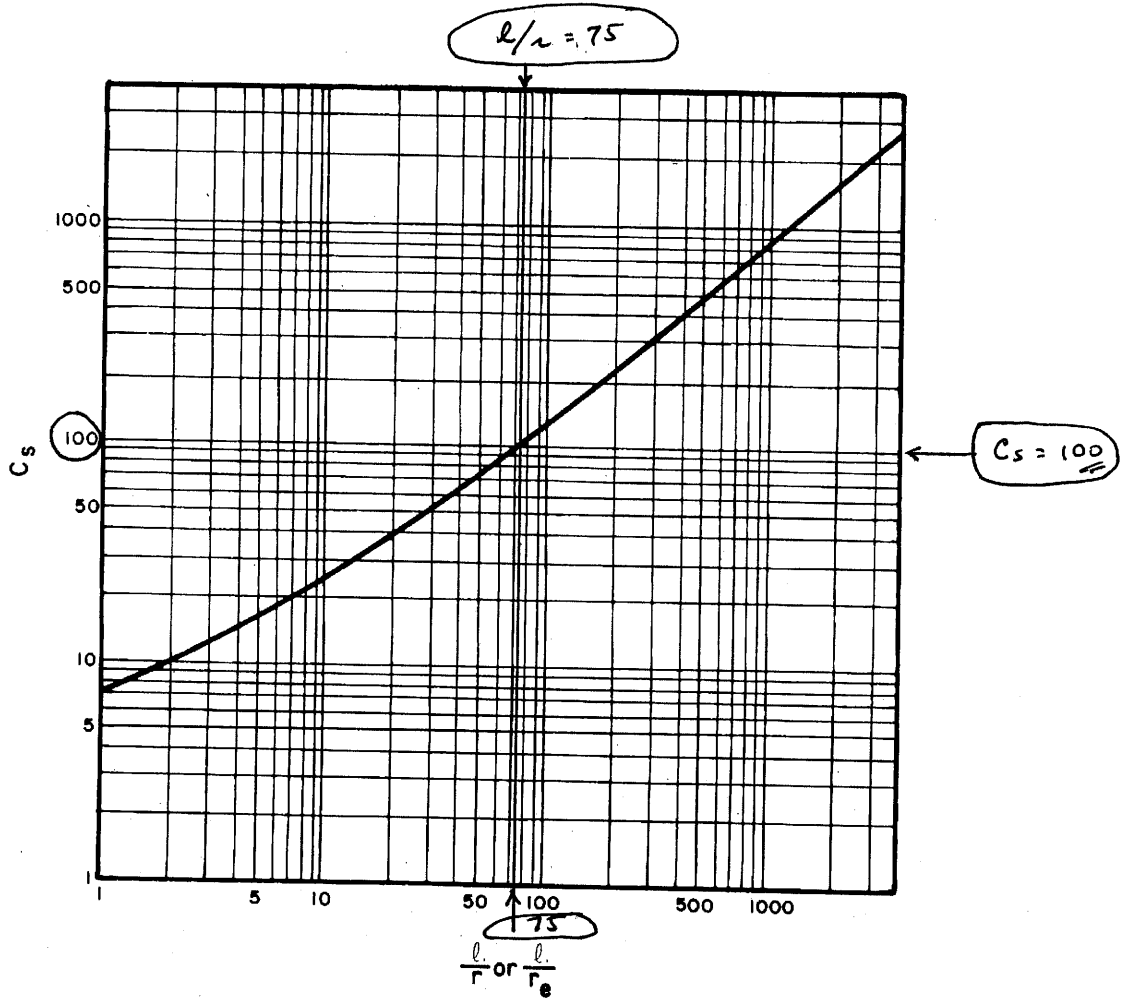

Figure 17-8.—Conductivity coefficients for semispherical flow in saturated materials through partially penetrating cylindrical test wells.

FIELD MANUAL

$$T_u = 75 - 65 + 125.1 = 135.1 \text{ feet}$$

$$X = \frac{125.1}{135.1} (100) = 92.6\% \quad \text{also} \quad \frac{T_u}{\ell} = \frac{135.1}{10} = 13.5$$

The test section is located in zone 2 (figure 17-6). To determine the saturated conductivity coefficient, C_s , from figure 17-8:

Borehole 208
Depth: 282-294 ft
Pressure: 5 psi
1-25-06

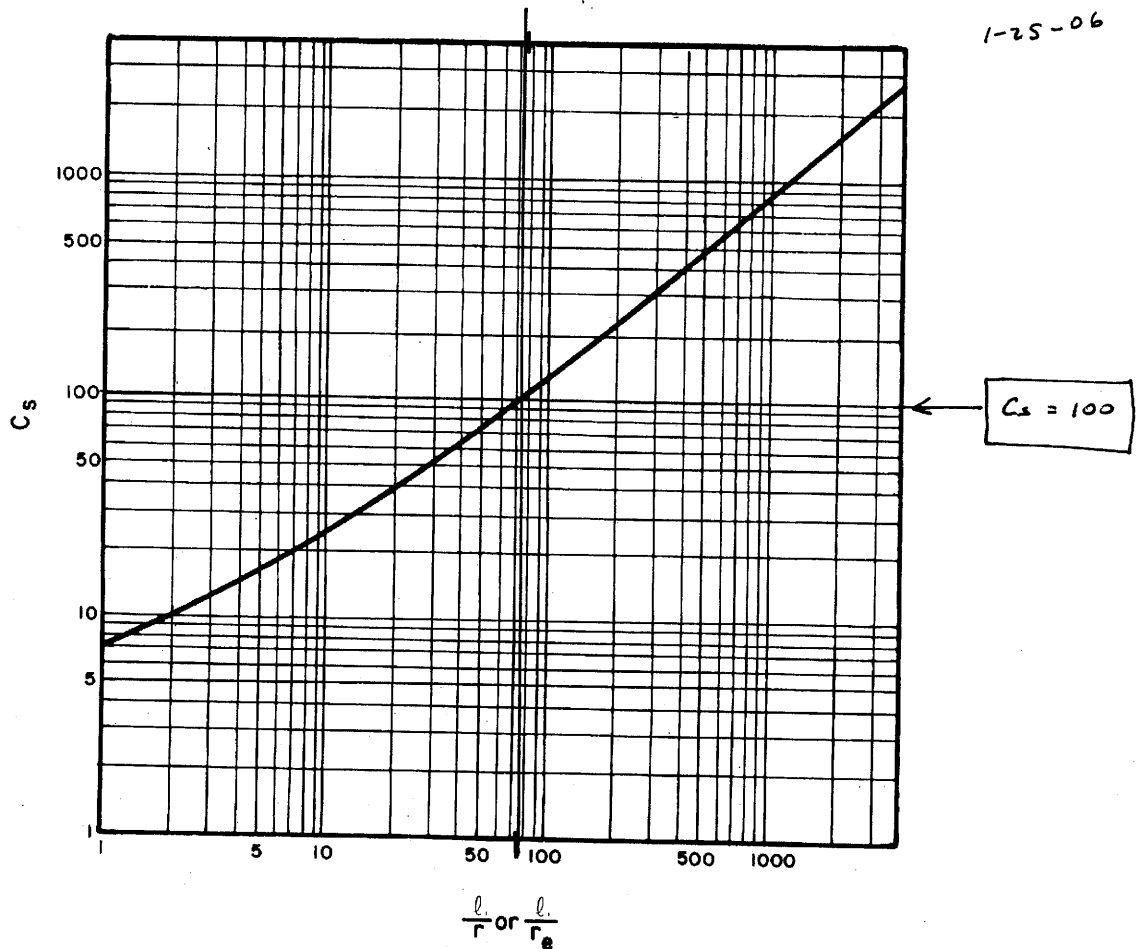

Figure 17-8.—Conductivity coefficients for semispherical flow in saturated materials through partially penetrating cylindrical test wells.

Stoller

For Straddle Pecker tests below water table
Zone 3; Method 2 USBR

JOB NO.: _____ DATE: 1-25-06

JOB NAME: Crescent Junction Site

PREPARED: M. Kautsky

REVIEWED: _____

SHEET NO.: _____ OF _____

Borehole 208

Depth 282-294

Pressure: 5 psi

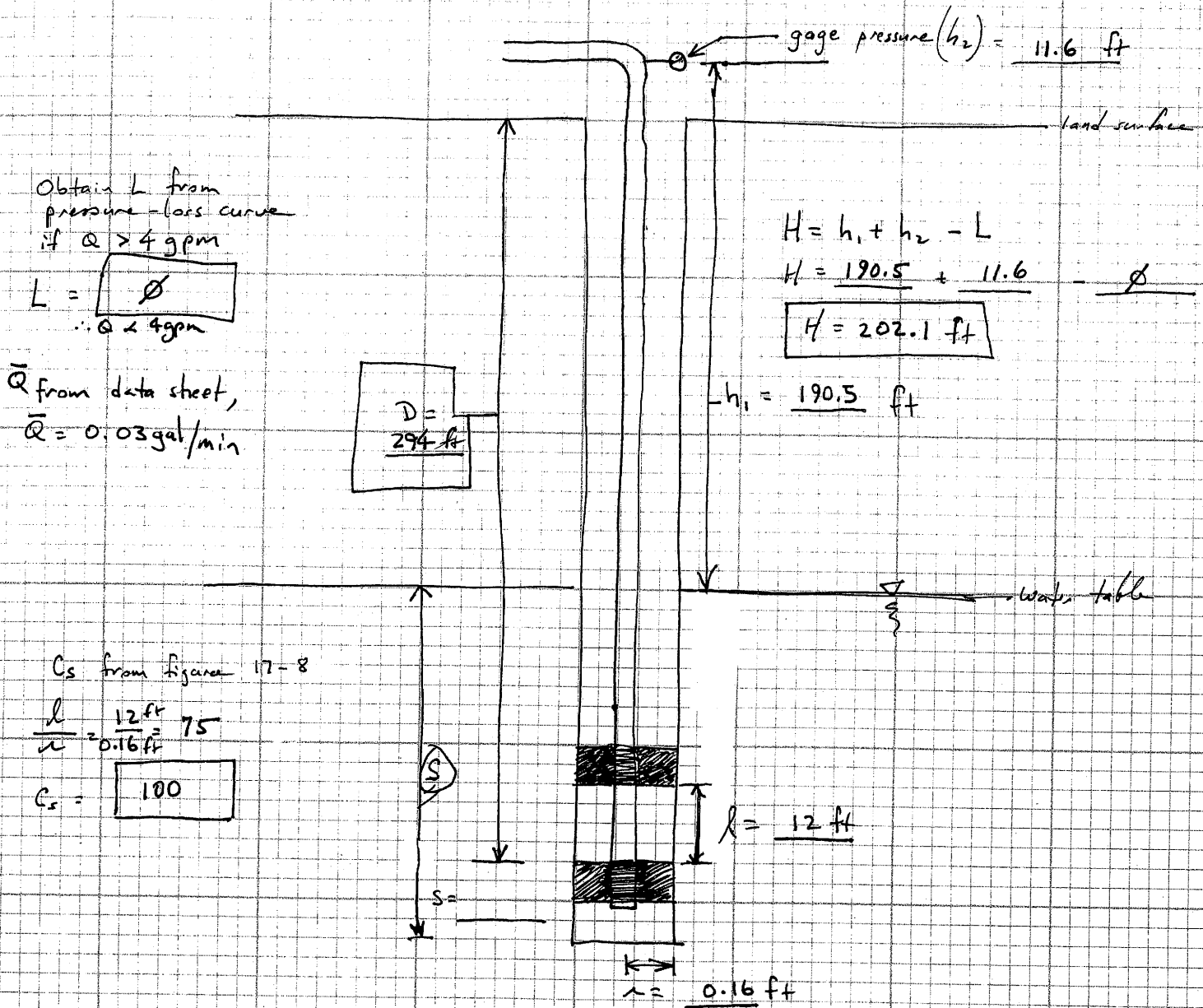

Obtain L from
pressure-loss curve
if $Q > 4 \text{ gpm}$

$$L = \boxed{\emptyset}$$

$\therefore Q < 4 \text{ gpm}$

\bar{Q} from data sheet,
 $\bar{Q} = 0.03 \text{ gal/min}$

$$D = \boxed{294 \text{ ft}}$$

$$H = h_1 + h_2 - L$$

$$H = 190.5 + 11.6 - \emptyset$$

$$H = \boxed{202.1 \text{ ft}}$$

$$h_1 = 190.5 \text{ ft}$$

C_s from figure 17-8

$$\frac{d}{a} = \frac{12 \text{ ft}}{0.16 \text{ ft}} = 75$$

$$C_s = \boxed{100}$$

$$R = 12 \text{ ft}$$

$$a = 0.16 \text{ ft}$$

$$K = \frac{Q}{C_s a H}$$

$$K = \frac{\left(\frac{0.03 \text{ gal}}{\text{min}} \right) \left(\frac{1440 \text{ min}}{d} \right) \left(\frac{1 \text{ ft}^3}{7.48 \text{ gal}} \right)}{100 (0.16 \text{ ft}) (202.1 \text{ ft})}$$

$$K = 1.8 \times 10^{-3} \text{ ft/d}$$

$$K = 6.3 \times 10^{-7} \text{ cm/d}$$

Stoller

For Straddle Packer Tests below water table
Zone 3; Method 2 USBR

JOB NO: _____ DATE: 1-25-06

JOB NAME: Crescent Junction site

PREPARED: M. Kautsky

REVIEWED: _____

SHEET NO.: _____ OF _____

Borehole 208

Depth 282-294 ft

Pressure: 10 psi

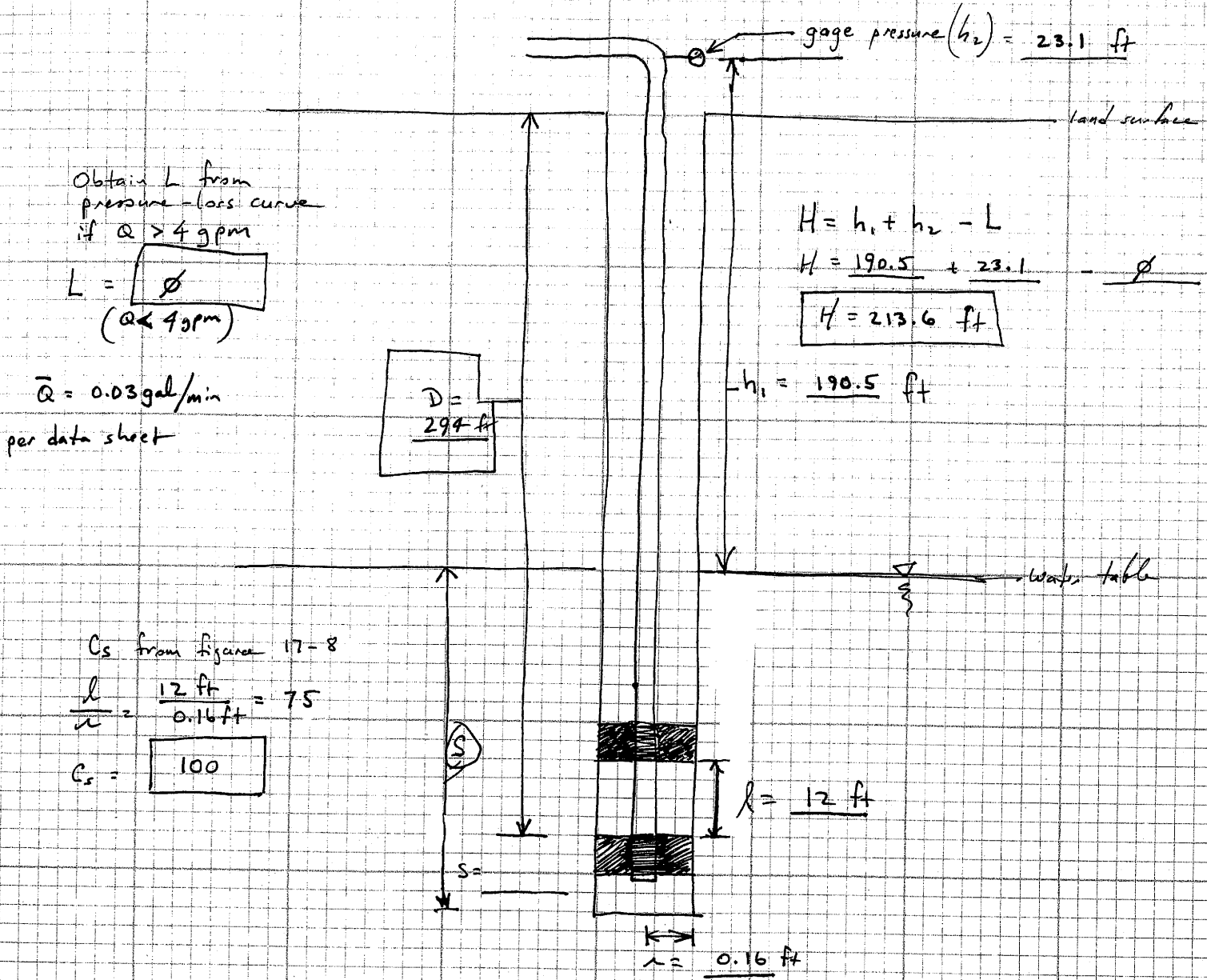

Obtain L from
pressure-loss curve
if $Q > 4$ gpm

$$L = \boxed{\phi}$$

($Q < 4$ gpm)

$\bar{Q} = 0.03$ gal/min
per data sheet

$$D = \boxed{294 \text{ ft}}$$

$$H = h_1 + h_2 - L$$

$$H = 190.5 + 23.1 - \phi$$

$$H = \boxed{213.6 \text{ ft}}$$

$$h_1 = 190.5 \text{ ft}$$

C_s from figures 17-8

$$\frac{l}{r} = \frac{12 \text{ ft}}{0.16 \text{ ft}} = 75$$

$$C_s = \boxed{100}$$

$$K = \frac{Q}{C_s \cdot l \cdot H}$$

$$K = \frac{0.03 \frac{\text{gal}}{\text{min}} \left(\frac{1440 \text{ min}}{d} \right) \left(\frac{\text{ft}^3}{7.48 \text{ gal}} \right)}{(100) (0.16 \text{ ft}) (213.6 \text{ ft})} =$$

$$1.7 \times 10^{-3} \text{ ft/d}$$

$$6.0 \times 10^{-7} \text{ cm/r}$$

Stoller

For Straddle Pecker Tests below water table
Zone 3; Method 2 USBR

JOB NO.: _____ DATE: 1-25-06

JOB NAME: Crescent Junction site

PREPARED: M. Kautsley

REVIEWED:

Borehole: 208

SHEET NO.: _____ OF _____

Depth: 282-294

Pressure: 20 psi

Obtain L from
pressure-loss curve
if $Q > 4$ gpm

$$L = \boxed{\phi}$$

($Q < 4$ gpm)

$Q < 0.01$ gal/30min

-4

$Q < 3.33 \times 10^{-4}$ gal/min
per data sheet

$$D = \boxed{294 \text{ ft}}$$

$$H = h_1 + h_2 - L$$

$$H = 190.5 + 46.2 - \phi$$

$$H = \boxed{236.7 \text{ ft}}$$

$$-h_1 = 190.5 \text{ ft}$$

$$l = 12 \text{ ft}$$

$$r = 0.16 \text{ ft}$$

C_s from figures 17-8

$$\frac{l}{r} = \frac{12 \text{ ft}}{0.16 \text{ ft}} = 75$$

$$C_s = \boxed{100}$$

$$K = \frac{Q}{C_s \cdot r \cdot H}$$

$$K < \frac{(3.33 \times 10^{-4} \text{ gal/min}) \left(\frac{1440 \text{ min}}{d}\right) \left(\frac{\text{ft}^3}{7.48 \text{ gal}}\right)}{(100) (0.16 \text{ ft}) (236.7 \text{ ft})} = 1.7 \times 10^{-5} \text{ ft/d}$$

$$K < 1.7 \times 10^{-5} \text{ ft/d} ; K < 6.0 \times 10^{-9} \text{ cm/s}$$

Stoller

For Straddle Packer Tests below water table
Zone 3; Method 2 USBR

JOB NO.: _____ DATE: 1-25-06

JOB NAME: Crescent Junction site

PREPARED: M. Kautsky

REVIEWED: _____

SHEET NO.: _____ OF _____

Borehole 208

Depth: 282-294

pressure: 10 psi
re test

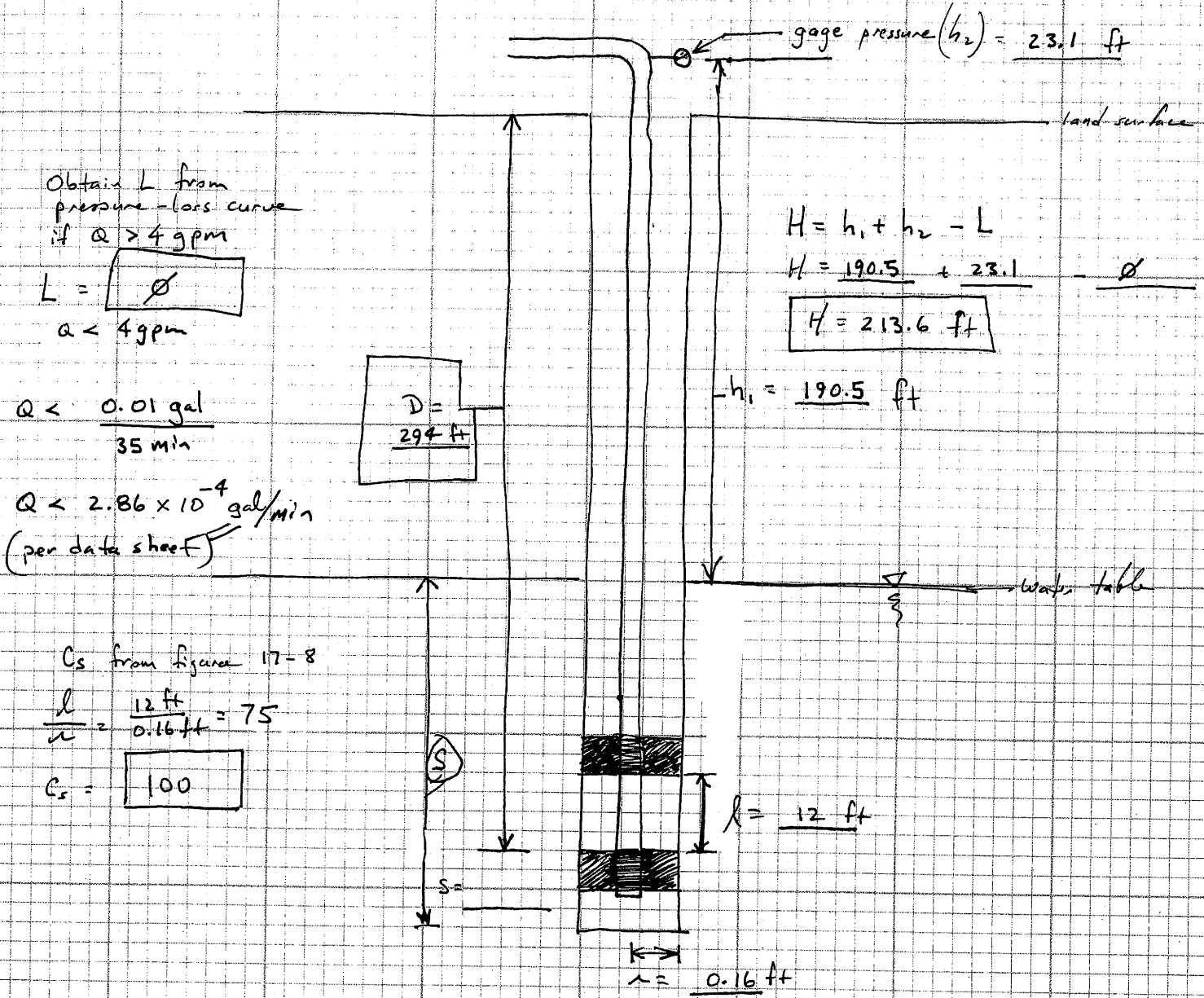

Obtain L from
pressure-loss curve
if $Q > 4 \text{ gpm}$

$$L = \boxed{\emptyset}$$

$Q < 4 \text{ gpm}$

$$Q < \frac{0.01 \text{ gal}}{35 \text{ min}}$$

$$Q < 2.86 \times 10^{-4} \text{ gal/min}$$

(per data sheet)

$$D = \boxed{294 \text{ ft}}$$

$$H = h_1 + h_2 - L$$

$$H = 190.5 + 23.1 - \emptyset$$

$$H = \boxed{213.6 \text{ ft}}$$

$$h_1 = 190.5 \text{ ft}$$

C_s from figure 17-8

$$\frac{l}{u} = \frac{12 \text{ ft}}{0.16 \text{ ft}} = 75$$

$$C_s = \boxed{100}$$

$$l = 12 \text{ ft}$$

$$d = 0.16 \text{ ft}$$

$$K = \frac{Q}{C_s \cdot H}$$

$$K < \frac{(2.86 \times 10^{-4} \text{ gal/min}) \left(\frac{1440 \text{ min}}{d} \right) \left(\frac{1 \text{ ft}^3}{7.48 \text{ gal}} \right)}{(100) (0.16 \text{ ft}) (213.6 \text{ ft})}$$

$$K < 1.6 \times 10^{-5} \text{ ft/d} ; K < 5.7 \times 10^{-9} \text{ cm/a}$$

Stoller

For Straddle Pecker Tests below water table
Zone 3; Method 2 USBR

JOB NO.: _____ DATE: 1-25-06

JOB NAME: Crescent Junction site

PREPARED: M. Kautsky REVIEWED: _____

SHEET NO.: _____ OF _____

Borehole 208
Depth: 282-294
pressure: 5psi reflect

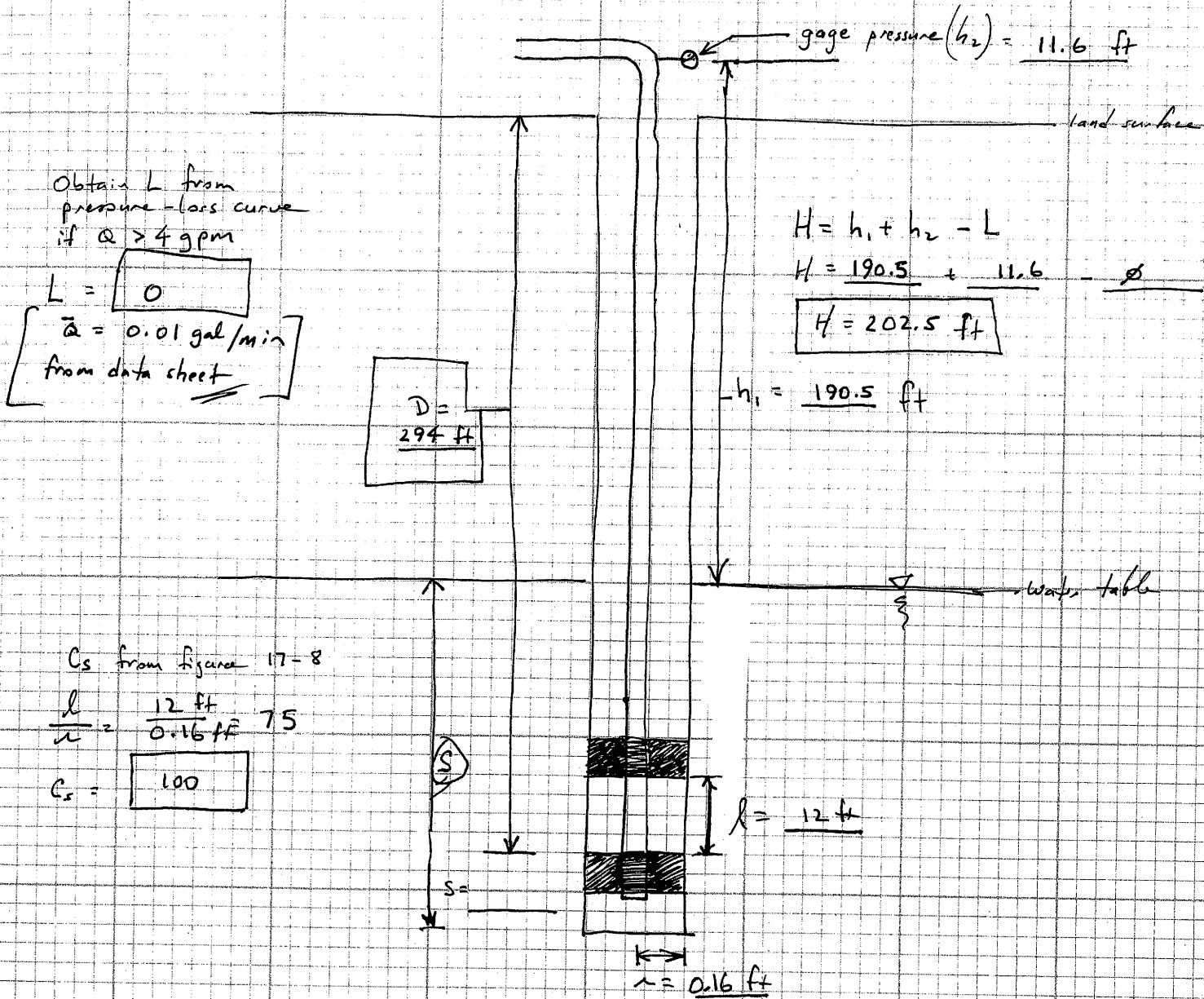

Obtain L from pressure-loss curve if $Q > 4 \text{ gpm}$

$L = 0$

$\bar{a} = 0.01 \text{ gal/min}$
from data sheet

$D = 294 \text{ ft}$

$H = h_1 + h_2 - L$
 $H = 190.5 + 11.6 - 0$

$H = 202.5 \text{ ft}$

$h_1 = 190.5 \text{ ft}$

C_s from Figure 17-8

$\frac{l}{r} = \frac{12 \text{ ft}}{0.16 \text{ ft}} = 75$

$C_s = 100$

$l = 12 \text{ ft}$

$r = 0.16 \text{ ft}$

$K = \frac{Q}{C_s r H}$

$K = \frac{(0.01 \frac{\text{gal}}{\text{min}}) (\frac{1440 \text{ min}}{d}) (\frac{\text{ft}^3}{7.48 \text{ gal}})}{(100) (0.16 \text{ ft}) (202.5 \text{ ft})}$

$K = 6.0 \times 10^{-4} \text{ ft/d} ; K = 2.1 \times 10^{-7} \text{ cm/s}$

U.S. Department of Energy—Grand Junction, Colorado

Calculation Cover Sheet

Calc. No.: MOA-02-04-2006-2-03-00 Discipline: Hydrologic Properties No. of Sheets: 8
Doc. No.: X0149600

Location: Attachment 3, Appendix D

Project: Moab UMTRA Project

Site: Crescent Junction Disposal Site, Utah

Feature: Hydrologic Characterization – Ground Water Pumping Records

Sources of Data:

Field records of ground water pumping (copies furnished in Appendix A)

Sources of Formulae and References:

DOE (U.S. Department of Energy) 2005. *Work Plan for Characterization of the Crescent Junction, Utah, Disposal Site*, DOE-EM/GJ912-2005.

Preliminary Calc. Final Calc. Supersedes Calc. No.

Author:

Mark Kautz 5-31-07
Name Date

Checked by:

Dave Peterson 5/31/07
Name Date

Approved by:

Mark Kautz 5/31/07
Name Date

[Signature] 31 May 07
Name Date

Craig Goodright 31 May 07
Name Date
[Signature] 5/31/07
Name Date

No text for this page

Problem Statement:

Preliminary site selection performed jointly by the U.S. Department of Energy (DOE) and the Contractor has identified a 2,300-acre withdrawal area in the Crescent Flat area just northeast of Crescent Junction, Utah, as a possible site for a final disposal cell for the Moab uranium mill tailings. The proposed disposal cell would cover approximately 250 acres. Based on the preliminary site-selection process, the suitability of the Crescent Junction disposal site is being evaluated from several technical aspects, including geomorphic, geologic, hydrologic, seismic, geochemical, and geotechnical. The objective of this calculation is to impart the volume of ground water pumped from the Mancos Shale during the investigation of subsurface conditions at the Crescent Junction Disposal Site.

This calculation will be incorporated into Attachment 3 (Hydrology) of the Remedial Action Plan and Site Design for Stabilization of Moab Title I Uranium Mill Tailings at the Crescent Junction, Utah, Disposal Site, and summarized in the appropriate sections of the Remedial Action Selection report for the Moab Site.

DOE (2005; p. 3–1) stated, “There are likely discontinuous saturated units within the Mancos Shale, but they are not anticipated to have significant lateral extent or interconnection, or contain usable ground water.” During site characterization, a total of ten coreholes were drilled to a depth of 300 feet at the locations shown in Figure 1, and ground water was encountered in seven of them. In five of the coreholes (0201, 0202, 0203, 0204, 0208) the ground water was found to be highly saline, possibly exceeding the salinity levels found in seawater (total dissolved solids [TDS] approximately 34,500 milligrams per liter [mg/L]). Based on its occurrence and composition, the water intersected by these coreholes appears to be *connate water*, or in other words, water that has been trapped in the pores of the rock since the rock (Mancos Shale) was formed.

In the two other coreholes containing ground water at the site (0205 and 0210), water-level recovery rates are very slow; consequently, ground water has not been pumped systematically from either location. One water sample collected from corehole 0210 was found to be very saline (TDS = 37,000 mg/L). Ground water from corehole 0205 has not been sampled but is also expected to be saline.

Pumping began in October 2005 at corehole 0208 and was followed shortly thereafter with pumping from the remaining coreholes. This calculation documents the volume of ground water extracted between October 31, 2005 and March 15, 2006.

Method of Solution:

Submersible pumps, which were powered with a portable generator, were installed in coreholes 0201, 0202, 0203, 0204, and 0208 shortly after the coreholes were drilled. Locations of the coreholes are shown in Figure 1. Discharge from each corehole was piped through a flow meter prior to being released at the land surface. Flow-meter readings were taken each time a corehole was evacuated. The incremental flow-meter readings were entered into an Excel spreadsheet, and the cumulative flows were determined by summation.

Assumptions:

- Per the assumption stated in the work plan (DOE 2005; p. 3–1), ground water at the site was anticipated to occur in discontinuous water-bearing conduits within the Mancos Shale.
- If the submersible pump is set at a fixed elevation in a formation with discontinuous water-bearing conduits, systematic pumping through time will gradually yield lesser volumes of ground water.

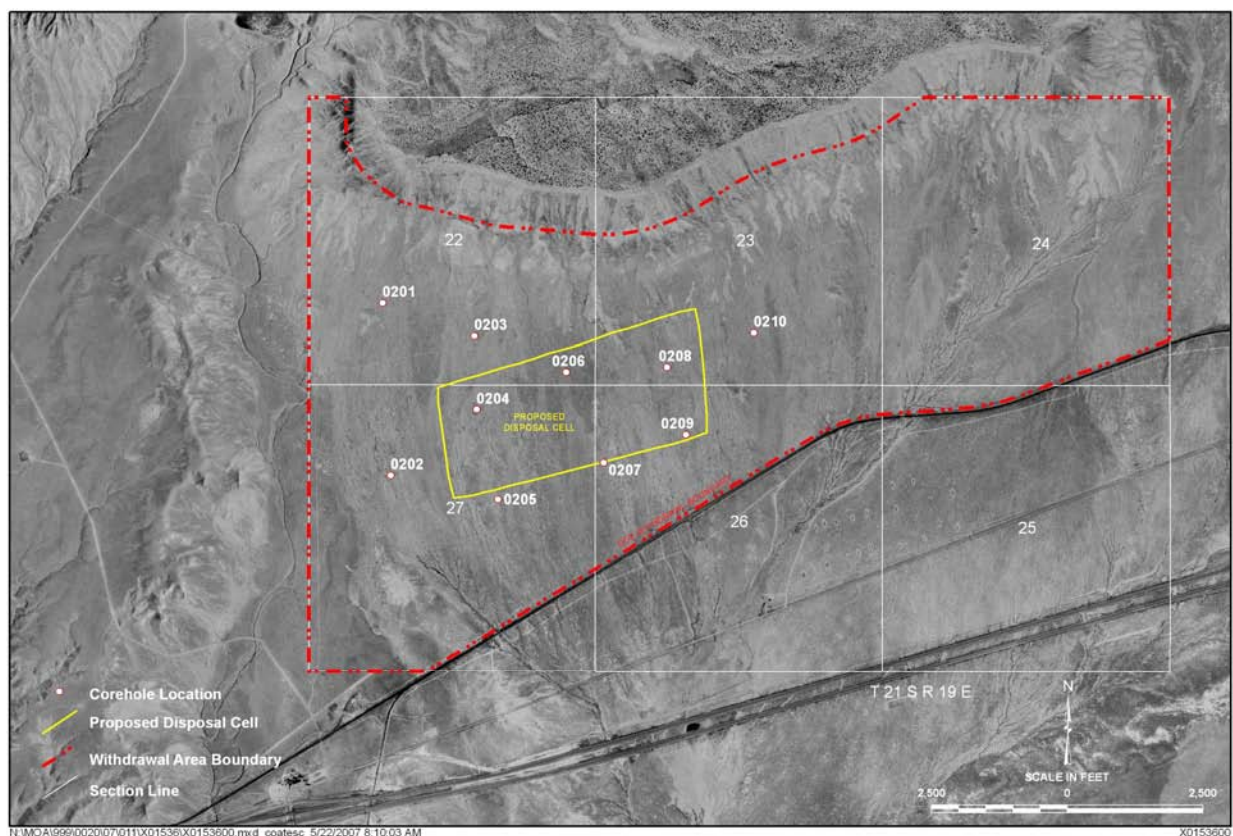

Figure 1. Map of Corehole Locations at the Crescent Junction Site

Calculation:

The objective of ground water pumping at the Crescent Junction Site has been to test the hypothesis that the ground water occurs in discontinuous water-bearing conduits within the Mancos Shale. It was reasoned that systematic pumping of the ground water would gradually deplete the source of connate water entering the coreholes if the ground water occurs in discontinuous water-bearing conduits.

Figures 2 through 6 present the incremental and cumulative pumping results to date for each corehole. As of March 17, 2006, a total of approximately 8,270 gallons had been removed from the five coreholes that contain connate water. The extracted amounts range from approximately 569 gallons from corehole 0204 to approximately 3,395 gallons from corehole 0203.

Analysis of the pumping curves in Figures 2 through 6 and the pumping data in Appendix A show that pumping first began in corehole 0208 and was followed with pumping from corehole 0203. A hiatus occurred from December 2, 2005, to mid-January 2006, during which time no pumping occurred. During the second week of January 2006, pumps were installed in coreholes 0201, 0202, and 0204, and regular systematic pumping began at all five coreholes.

A qualitative analysis presented in Figures 2 through 6 shows that the incremental pumping volumes remained steady and the slope of the cumulative pumping curves remained unchanged at coreholes 0201, 0203, 0204, and 0208. This observation contrasts with an apparent decrease in incremental pumping volumes at corehole 0202 and a reduction in the slope of the cumulative pumping curve, which began at the end of January 2006. The qualitative results may indicate that the source of connate water to corehole 0202 is being depleted; however, the same cannot be said for coreholes 0201, 0203, 0204, and 0208.

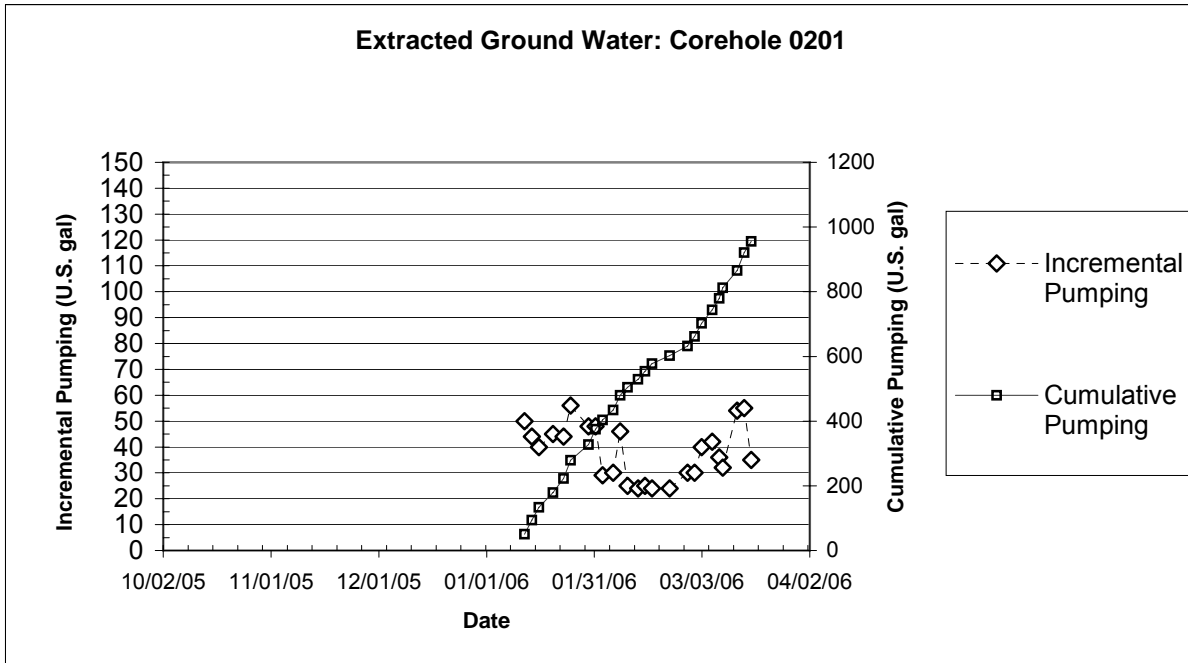

Figure 2. Ground Water Withdrawal from Corehole 0201, Crescent Junction, Utah, Disposal Site

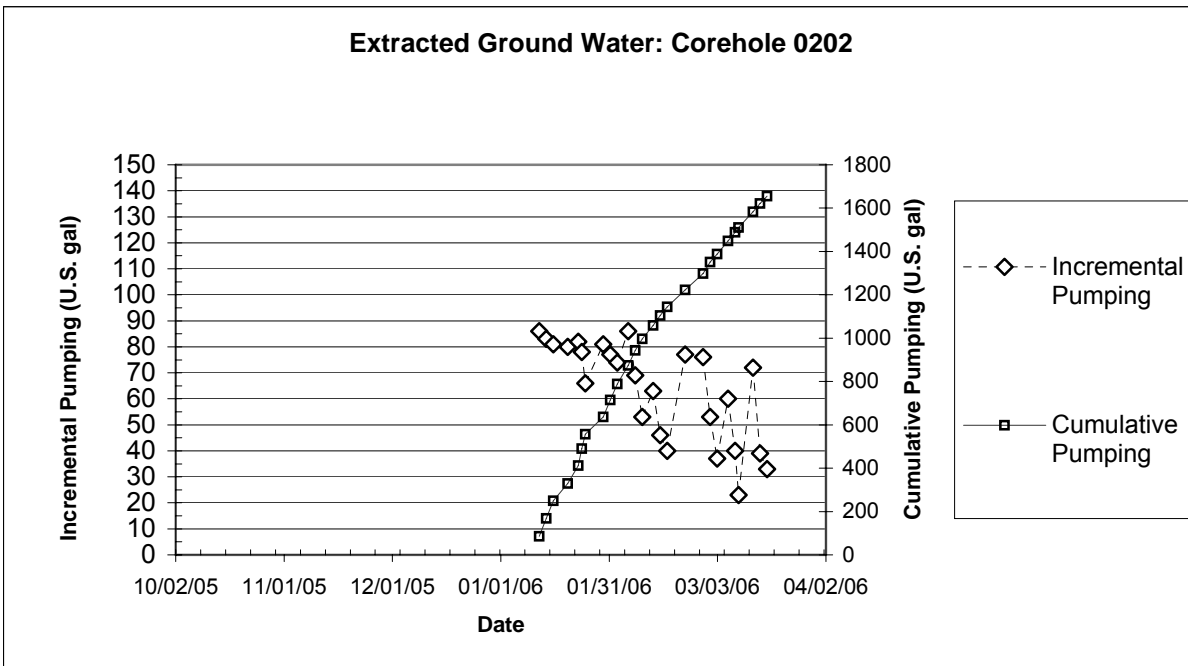

Figure 3. Ground Water Withdrawal from Corehole 0202, Crescent Junction, Utah, Disposal Site

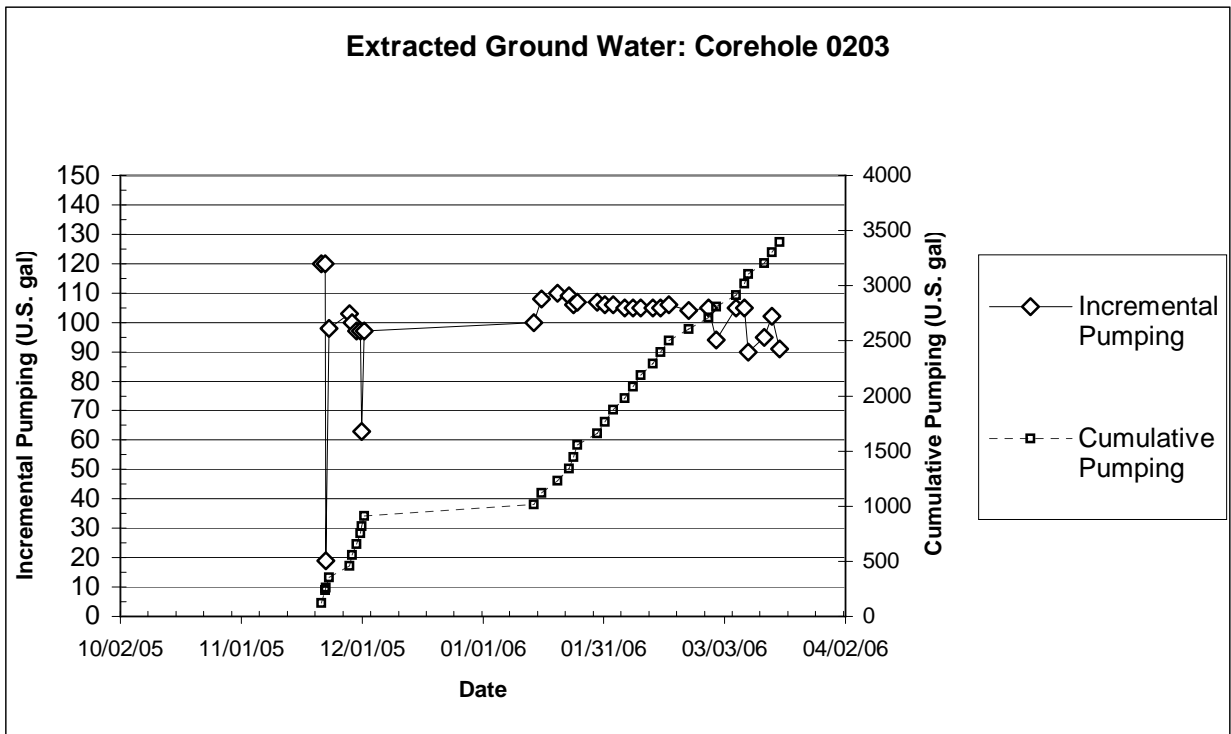

Figure 4. Ground Water Withdrawal from Corehole 0203, Crescent Junction, Utah, Disposal Site

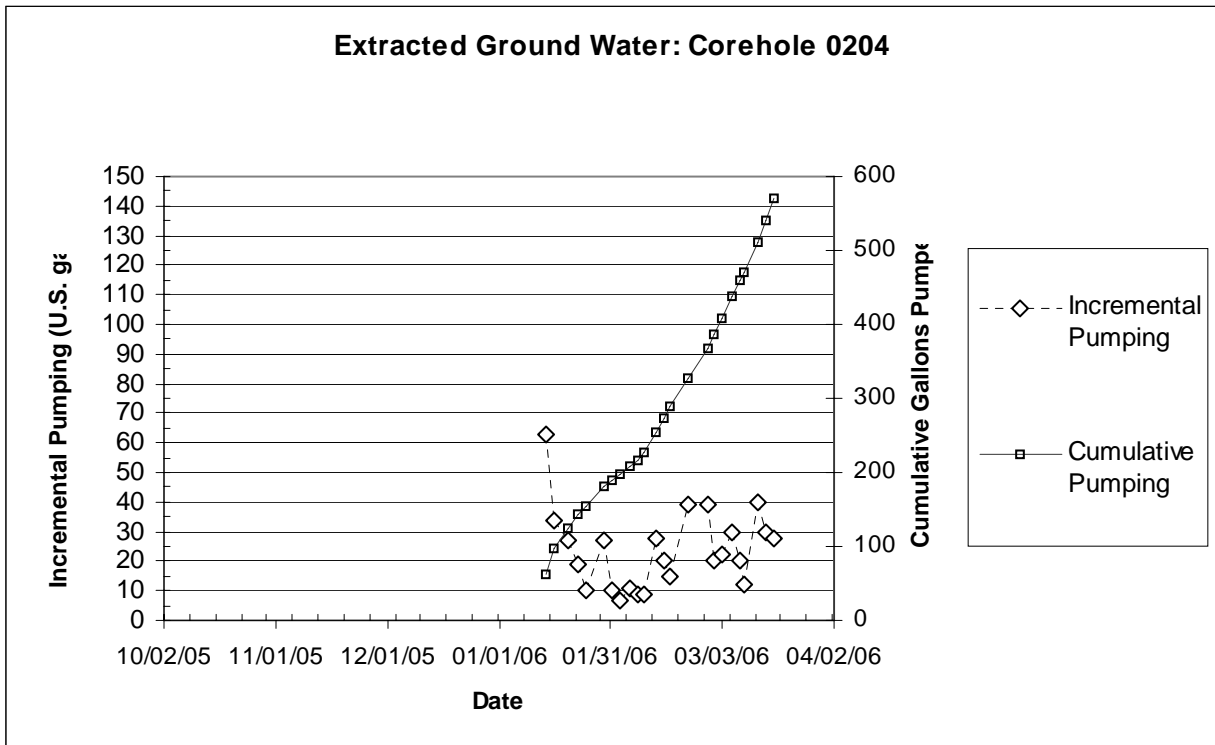

Figure 5. Ground Water Withdrawal from Corehole 0204, Crescent Junction, Utah, Disposal Site

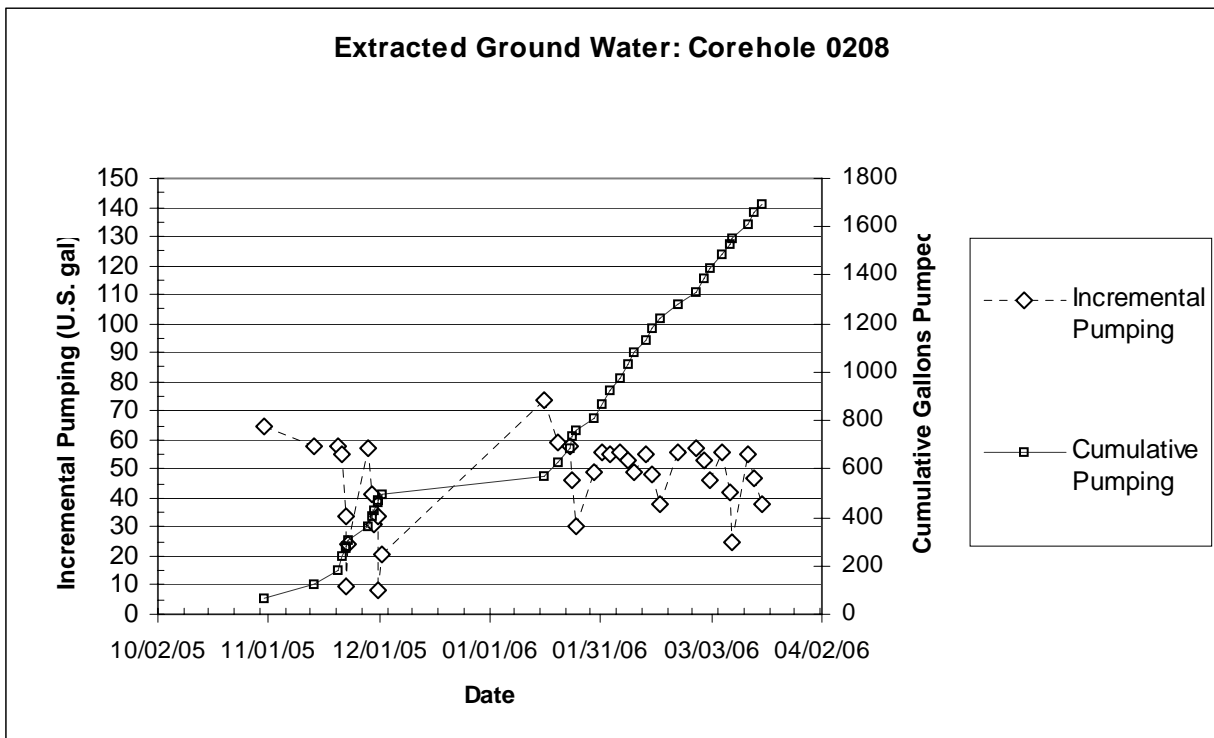

Figure 6. Ground Water Withdrawal from Corehole 0208, Crescent Junction, Utah, Disposal Site

Discussion:

N/A

Conclusion and Recommendations:

The purpose of pumping connate water from the coreholes at the Crescent Junction Disposal Site has been to test the concept that the water occurs in discontinuous and isolated zones or porous compartments. Persistent pumping from zones containing limited volumes of trapped water should eventually yield decreased volumes of produced water and a flattening of the cumulative recovery curve. Such behavior would typify incipient source depletion.

As of March 17, 2006, the pumping data have shown that the incremental pumping volumes have declined, and the cumulative recovery curve has begun to flatten at corehole 0202. Coreholes 0201, 0203, 0204, and 0208 have continued to yield water at relatively constant rates, signifying that the connate water intercepted by these coreholes is stored in larger compartments, which will require more pumping to deplete. The continued pumping from these larger compartments is deemed unnecessary because the concept that the connate water is trapped in porous zones with limited volume was already demonstrated at corehole 0202. In addition, coreholes 0206, 0207, and 0209 have never contained any water since the holes were drilled, which further supports the position that the connate water is present in discontinuous pockets.

Other important aspects of the ground water hydrology that should be considered are the static water levels, the ground water chemistry, and the effect that repeated pumping has had on them. Therefore, we recommend that systematic pumping from the coreholes should be permanently discontinued to allow static water levels to recover and to collect additional baseline water samples.

Computer Source:

Microsoft Excel

End of current text

Appendix A

Field Records of Ground Water Pumping

Well #	Date	Gallons Purged	Cumulative Purged
201	01/12/06	50	50
	01/14/06	44	94
	01/16/06	40	134
	01/20/06	45	179
	01/23/06	44	223
	01/25/06	56	279
	01/30/06	48	327
	02/01/06	48	375
	02/03/06	29	404
	02/06/06	30	434
	02/08/06	46	480
	02/10/06	25	505
	02/13/06	24	529
	02/15/06	25	554
	02/17/06	24	578
	02/22/06	24	602
	02/27/06	30	632
	03/01/06	30	662
	03/03/06	40	702
	03/06/06	42	744
	03/08/06	36	780
	03/09/06	32	812
	03/13/06	54	866
	03/15/06	55	921
	03/17/06	35	956

Well #	Date	Gallons Purged	Cumulative Purged
202	01/12/06	86	86
	01/14/06	83	169
	01/16/06	81	250
	01/20/06	80	330
	01/23/06	82	412
	01/24/06	78	490
	01/25/06	66	556
	01/30/06	81	637
	02/01/06	77	714
	02/03/06	74	788
	02/06/06	86	874
	02/08/06	69	943
	02/10/06	53	996
	02/13/06	63	1059
	02/15/06	46	1105
	02/17/06	40	1145
	02/22/06	77	1222
	02/27/06	76	1298
	03/01/06	53	1351
	03/03/06	37	1388
	03/06/06	60	1448
	03/08/06	40	1488
	03/09/06	23	1511
	03/13/06	72	1583
	03/15/06	39	1622
	03/17/06	33	1655

Well #	Date	Gallons Purged	Cumulative Purged
203	11/21/05	120	120
	11/22/05	120	240
	11/22/05	19	259
	11/23/05	98	357
	11/28/05	103	460
	11/29/05	100	560
	11/30/05	97	657
	12/01/05	97	754
	12/01/05	63	817
	12/02/05	97	914
	01/14/06	100	1014
	01/16/06	108	1122
	01/20/06	110	1232
	01/23/06	109	1341
	01/24/06	106	1447
	01/25/06	107	1554
	01/30/06	107	1661
	02/01/06	106	1767
	02/03/06	106	1873
	02/06/06	105	1978
	02/08/06	105	2083
	02/10/06	105	2188
	02/13/06	105	2293
	02/15/06	105	2398
	02/17/06	106	2504
	02/22/06	104	2608
	02/27/06	105	2713
	03/01/06	94	2807
	03/06/06	105	2912
	03/08/06	105	3017
	03/09/06	90	3107
	03/13/06	95	3202
	03/15/06	102	3304
	03/17/06	91	3395

Well #	Date	Gallons Purged	Cumulative Purged
204	01/14/06	63	63
	01/16/06	34	97
	01/20/06	27	124
	01/23/06	19	143
	01/25/06	10	153
	01/30/06	27	180
	02/01/06	10	190
	02/03/06	7	197
	02/06/06	11	208
	02/08/06	9	217
	02/10/06	9	226
	02/13/06	28	254
	02/15/06	20	274
	02/17/06	15	289
	02/22/06	39	328
	02/27/06	39	367
	03/01/06	20	387
	03/03/06	22	409
	03/06/06	30	439
	03/08/06	20	459
	03/09/06	12	471
	03/13/06	40	511
	03/15/06	30	541
	03/17/06	28	569

Well #	Date	Gallons Purged	Cumulative Purged
208	10/31/05	65	65
	11/14/05	58	123
	11/20/05	57.5	180.5
	11/21/05	54.9	235.4
	11/22/05	33.4	268.8
	11/22/05	9.5	278.3
	11/23/05	24	302.3
	11/28/05	57.3	359.6
	11/29/05	41	400.6
	11/30/05	31.1	431.7
	12/01/05	33.6	465.3
	12/01/05	8.3	473.6
	12/02/05	20.8	494.4
	01/16/06	73.6	568
	01/20/06	59	627
	01/23/06	58	685
	01/24/06	46	731
	01/25/06	30	761
	01/30/06	49	810
	02/01/06	56	866
	02/03/06	55	921
	02/06/06	56	977
	02/08/06	53	1030
	02/10/06	49	1079
	02/13/06	55	1134
	02/15/06	48	1182
	02/17/06	38	1220
	02/22/06	56	1276
	02/27/06	57	1333
	03/01/06	53	1386
	03/03/06	46	1432
	03/06/06	56	1488
	03/08/06	42	1530
	03/09/06	25	1555
	03/13/06	55	1610
	03/15/06	47	1657
	03/17/06	38	1695

End of current text

U.S. Department of Energy—Grand Junction, Colorado

Calculation Cover Sheet

Calc. No.: MOA-02-05-2006-2-13-00
Doc. No.: X0173300

Discipline: Hydrology

No. of Sheets: 10

Location: Attachment 3, Appendix E

Project: Moab UMTRA Project

Site: Crescent Junction Disposal Site

Feature: Hydrologic Characterization – Vertical Travel Time to Uppermost (Dakota) Aquifer

Sources of Data:

Published literature and maps within 30-mile radius of the Crescent Junction Disposal Site (see below).
Water level elevation data for Mancos Shale from SEEPPro database.
Remedial Action Plan (RAP) calculations as referenced in the text.

Sources of Formulae and References:

See "References" section.

Preliminary Calc. Final Calc. Supersedes Calc. No.

Author: Mark Kautsky 5-31-07 Checked by: J. Cummings 5/31/07
Name Date Name Date

Approved by: Kend Hupp 5/31/07
Name Date

D. White 5/31/07
Name Date

No text for this page

Problem Statement:

Preliminary site selection performed jointly by the U.S. Department of Energy (DOE) and the Contractor has identified a 2,300-acre withdrawal area in the Crescent Flat area just northeast of Crescent Junction, Utah, as a possible site for a final disposal cell for the Moab uranium mill tailings. The proposed disposal cell would cover approximately 250 acres. Based on the preliminary site-selection process, the suitability of the Crescent Junction Disposal Site is being evaluated from several technical aspects including geomorphic, geologic, hydrologic, seismic, geochemical, and geotechnical. The objective of this calculation set is to estimate the vertical travel time for ground water migrating from the Crescent Junction Disposal Site through the Mancos Shale confining unit to the Dakota aquifer.

Conclusions from these data will be incorporated into the Remedial Action Selection Report of the Remedial Action Plan (RAP) and Site Design for Stabilization of Moab Title I Uranium Mill Tailings at the Crescent Junction, Utah, Disposal Site.

Method of Solution:

The time required for ground water to migrate from the disposal site through the Mancos Shale to the Dakota aquifer is estimated in this calculation. Figure 1 presents a cross-sectional diagram showing the geologic profile that underlies the proposed Crescent Junction disposal cell. Each of the variables required to analytically assess vertical flow are shown in Figure 1. The average linear velocity, which stems from Darcy's Law, is used to estimate the downward rate of ground water movement. Key elements of the average linear velocity calculation are presented below:

$$V = q/n_e = (-K \, dh/dz)/n_e$$

where

V = average linear velocity (L/T)

q = specific discharge (L^3/L^2T), or simply (L/T)

K = hydraulic conductivity (L/T)

dh/dz = vertical hydraulic gradient (L/L), or simply (dimensionless)

n_e = effective porosity (L^3/L^3), or simply (dimensionless)

where L = length units and T = time units

Ground water levels were measured in coreholes 0201, 0202, 0203, 0204, 0205, 0208, and 0210 at the Crescent Junction Disposal Site. After the water level data were gathered, they were entered into the SEEPro database and used to plot the ground water elevations presented in Figure 2. The measured ground water levels in the Mancos Shale, which are given the symbol h_1 in Figure 1, range in elevation from 4,650 to 4,920 feet (ft) above mean sea level. The hydraulic head value of 4,920 ft is used in the calculation because it yields the shortest travel time to the Dakota aquifer.

Ground water levels from the Dakota aquifer are presented in Figure 3, which was modified after Freethey and Cordy (1991). Potentiometric surface contours were extrapolated into the area of the site, which occupies the area 38.96° north by 109.80° west. As shown on Figure 3 the elevation of the potentiometric surface of the Dakota aquifer is approximately 4,700 ft above mean sea level. In Figure 1 the potentiometric surface of the Dakota aquifer is designated with the symbol h_2 .

Geological data presented in the "Surficial and Bedrock Geology of the Crescent Junction Disposal Site" calculation (RAP Attachment 2, Appendix B) shows that the vertical distance from the land surface to the top of the Dakota aquifer is approximately 2,400 ft. Because the minimum depth to water in the coreholes at the site is approximately 100 ft, the vertical flow path, which is designated by the letter ℓ , extends from the measured water surface in coreholes to the Dakota aquifer: a distance of approximately 2,300 ft. The time required for drainage to migrate from the bottom of the disposal cell to the first occurrence of ground water is neglected in this calculation.

Stoller

JOB NO.: _____ DATE: _____
JOB NAME: _____
PREPARED: _____ REVIEWED: _____
SHEET NO.: _____ OF _____

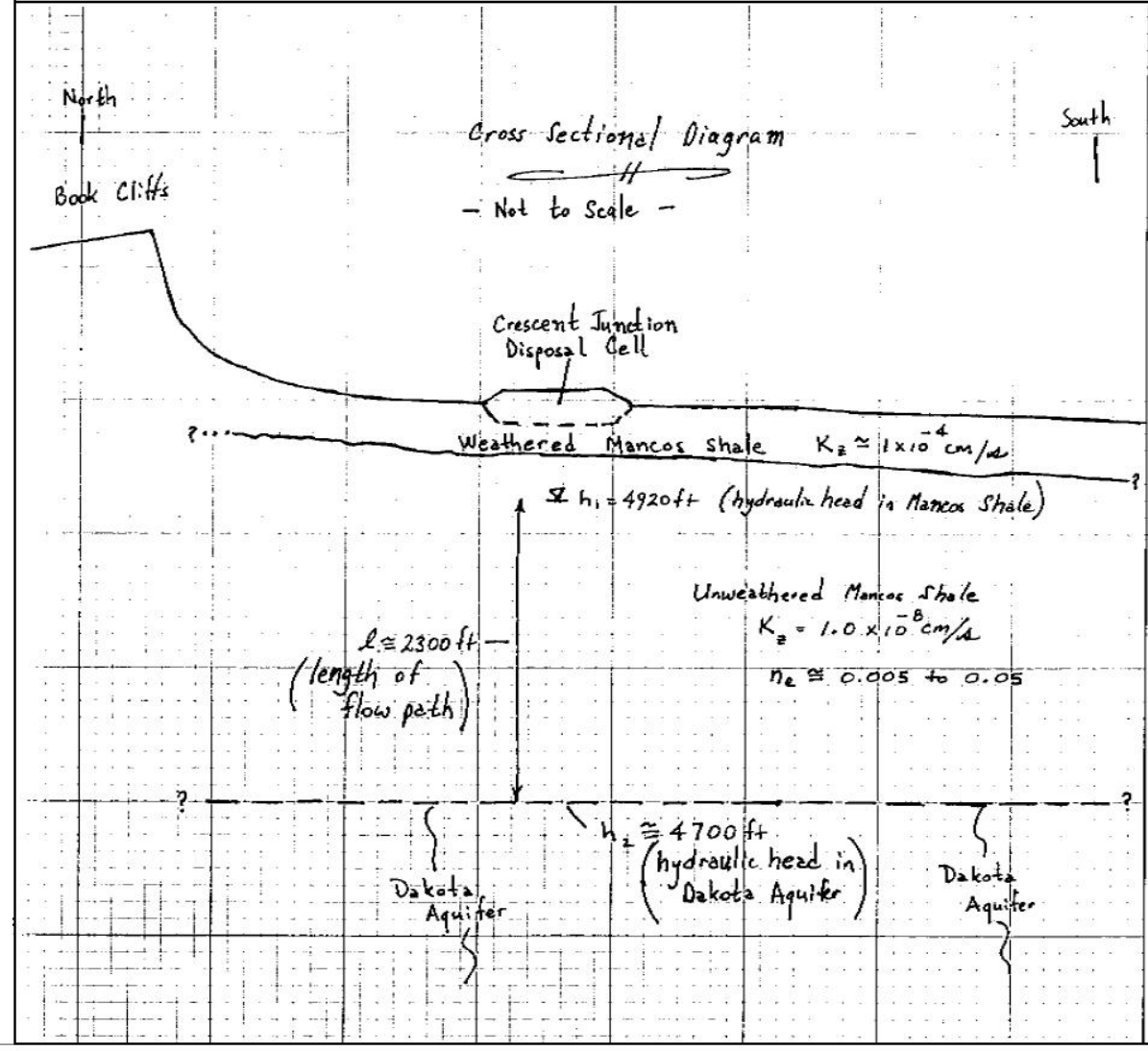

Figure 1. Schematic Cross Section through Crescent Junction, Utah, Disposal Cell

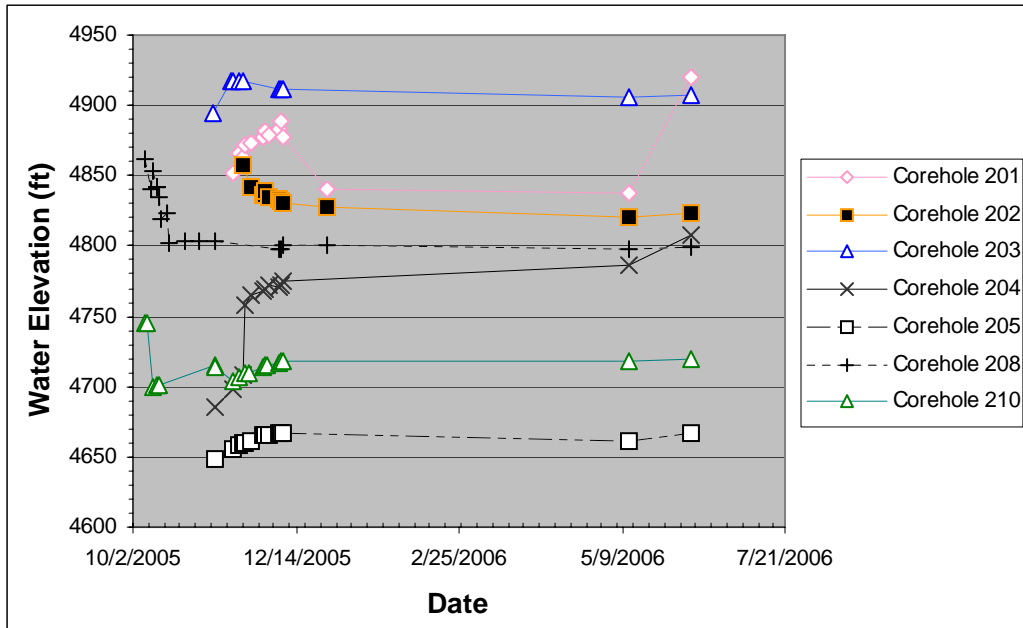

Figure 2. Ground Water Elevations Measured at Crescent Junction Disposal Site, Utah

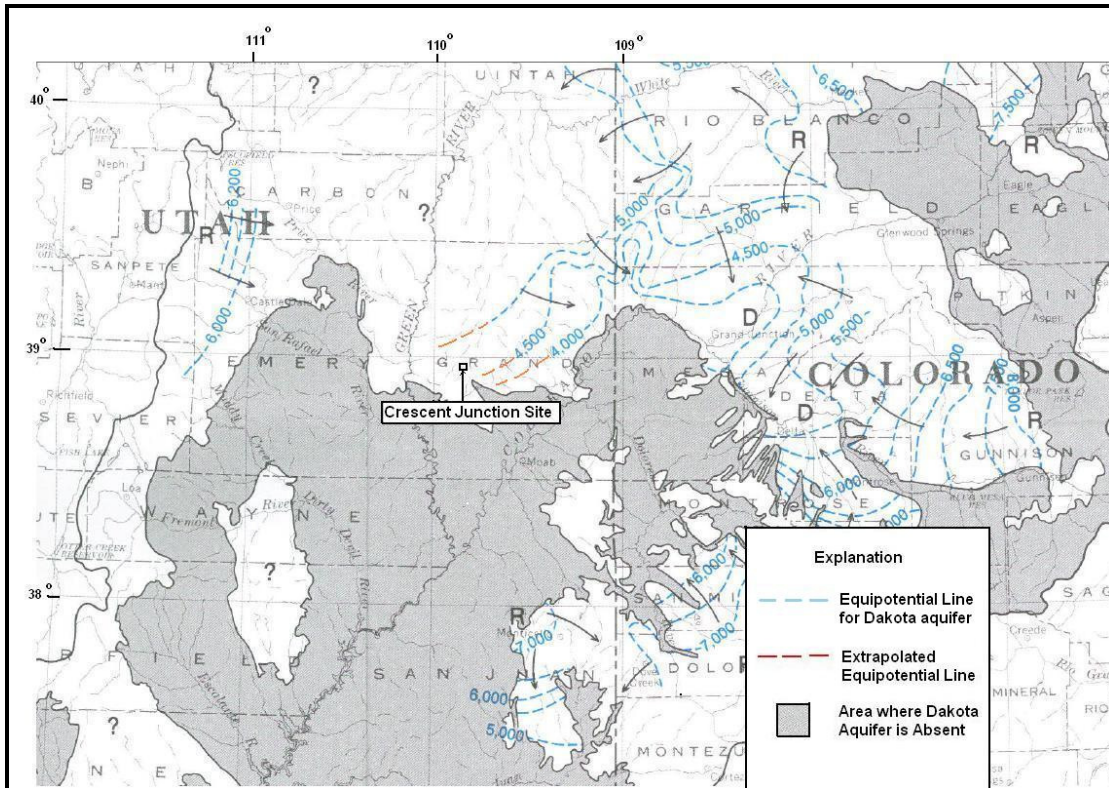

Figure 3. Map showing Generalized Potentiometric Surface and Extrapolated Potentiometric Surface into Crescent Junction Disposal Site (after Freethy and Cordy, 1991, Plate 5)

Effective porosity of the Mancos Shale was not measured at the site during the investigation; consequently, it was estimated from literature values. The Nuclear Regulatory Commission suggests “an effective porosity of 10 percent is assumed conservative (represents the largest flow velocity), unless measured grain size and compaction information support a different value” (NRC 1993, p. 46). Effective porosity values for shale are reported to range from 0.5 to 5 percent (Domenico and Schwartz 1990, p. 26). Because these latter values are more conservative than the 10 percent values suggested by NRC, the effective porosity in this calculation is given the range 0.5 to 5 percent.

Hydraulic conductivity measurements of discrete intervals in the unweathered Mancos Shale were made using dual-packer tests. Results from these tests are presented in Table 1. The hydraulic conductivity data set is insufficient to ascertain its frequency distribution; however, the results are assumed to lie within a log normal distribution because randomly sampled hydraulic conductivity values typically fit a log normal distribution (Domenico and Schwartz 1990, p. 26). Also according to Domenico and Schwartz (1990, p. 66), the “average” value of hydraulic conductivity is represented by the geometric mean. The calculated geometric mean of the hydraulic conductivity data in Table 1 is 3.5×10^{-8} centimeters per second (cm/s).

Table 1. Summary of Field-Permeability “Packer” Test Results for the Crescent Junction Site

Hole ID @ Depth Interval (ft)	Calculated Permeability ¹ (cm/s)				
	Test 1	Test 2	Test 3	Test 4	Test 5
Dual-Packer Tests:					
0204 @ 80 to 92	J 1.3×10^{-8}	3.9×10^{-7}	J 9.6×10^{-9}	6.6×10^{-7}	J 1.3×10^{-8}
0204 @ 110 to 122	J 7.5×10^{-9}	9.1×10^{-8}	4.2×10^{-7}	J 9.1×10^{-8}	J 7.5×10^{-9}
0204 @ 283 to 295	J 8.9×10^{-9}	1.2×10^{-6}	2.6×10^{-6}	J 1.1×10^{-8}	J 1.2×10^{-8}
0208 @ 90 to 102	J 6.0×10^{-9}	J 7.7×10^{-9}	J 2.2×10^{-9}	J 7.7×10^{-9}	J 6.0×10^{-9}
0208 @ 121 to 133	J 8.0×10^{-9}	J 1.4×10^{-8}	7.5×10^{-7}	J 1.4×10^{-8}	J 8.0×10^{-9}
0208 @ 282 to 294	6.3×10^{-7}	6.0×10^{-7}	J 6.0×10^{-9}	J 5.7×10^{-9}	2.1×10^{-7}

¹J flag indicates a *no-flow* packer test in which a maximum hydraulic conductivity is calculated, based on duration of test (see “Field Permeability ‘Packer’ Test” calculation, RAP Attachment 3, Appendix C, for details).

Assumptions:

- Literature sources are reliable and representative of consensus of opinion.
- Hydraulic conductivity is a log normally distributed function.
- The actual value of effective porosity is within the range 0.005 to 0.05.
- Extrapolated value of hydraulic head for Dakota aquifer is accurate.
- Hydraulic head measurements obtained from the Mancos Shale represent perched, connate ground water without any connection to the Dakota aquifer.

Calculation:

Calculate specific discharge using Darcy's Law and the input values described above.

Specific Discharge Calculation

Calculate specific discharge using hydraulic-head value of 4,920 ft in Mancos Shale:

$$q = -K \, dh/dz = -(3.5 \times 10^{-8} \text{ cm/sec}) \times (4,920 \text{ ft} - 4,700 \text{ ft}) / (2,300 \text{ ft})$$

$$q = -3.35 \times 10^{-9} \text{ cm/sec (downward flow)}$$

Average Linear Velocity Calculation

Calculate average linear velocity using the downward specific discharge value and the values 0.005 and 0.05 for effective porosity:

Using $n_e = 0.005$:

$$V = q/n_e = (-3.35 \times 10^{-9} \text{ cm/sec}) / (0.005) = 6.70 \times 10^{-7} \text{ cm/sec}$$

Using $n_e = 0.05$:

$$V = q/n_e = (-3.35 \times 10^{-9} \text{ cm/sec}) / (0.05) = 6.70 \times 10^{-8} \text{ cm/sec}$$

Travel Time Calculation

Calculate travel time using the above-calculated velocities:

$$\text{Distance} = \text{rate} \times \text{time}; \text{ therefore, Time (t)} = (\text{distance}) / (\text{rate})$$

Travel time calculated based on velocity from $n_e = 0.005$:

$$\text{Time} = (2,300 \text{ ft}) / (6.70 \times 10^{-7} \text{ cm/sec}) \left(\frac{1.03 \times 10^6 \text{ ft/yr}}{\text{cm/sec}} \right) = 3,330 \text{ yr}$$

Travel time calculated based on velocity from $n_e = 0.05$:

$$\text{Time} = (2,300 \text{ ft}) / (4.59 \times 10^{-8} \text{ cm/sec}) \left(\frac{1.03 \times 10^6 \text{ ft/yr}}{\text{cm/sec}} \right) = 33,300 \text{ yr}$$

Discussion:

The travel time developed in this calculation for ground water to migrate from the disposal site through the Mancos Shale to the Dakota aquifer ranges from 3,330 to 33,300 years. An order-of-magnitude estimate seems appropriate for this calculation because uncertainties associated with three variables could have a strong effect on the outcome, namely: (1) the hydraulic gradient between the Mancos Shale and the Dakota aquifer, (2) the geometric mean hydraulic conductivity, and (3) the effective porosity. These variables are discussed briefly below.

(1) Hydraulic gradient between Mancos Shale and Dakota aquifer

Ground water levels from the Dakota aquifer are presented in Figure 3, which was modified after Freethey and Cordy (1991). Potentiometric surface contours were extrapolated into the area of the site. As shown on Figure 3 the elevation of the potentiometric surface of the Dakota aquifer is approximately 4,700 ft above mean sea level. The maximum hydraulic head of 4920 ft was measured at corehole 0201 (Figure 2) and the minimum hydraulic head of 4648 ft was measured at corehole 0205. Because the elevation of the extrapolated potentiometric surface of the Dakota aquifer is within the range of the measured heads in the Mancos Shale, there is some basis to suspect that the Mancos heads are expressing the potentiometric surface of the underlying Dakota aquifer. If this were the case, then the vertical hydraulic gradient across the Mancos Shale would be effectively zero and no potential would exist for vertical flow between the unstressed Mancos Shale system and the Dakota aquifer. Therefore, the estimated vertical travel times of 3,330 to 33,300 years are conservative.

(2) Geometric mean hydraulic conductivity

Site-specific packer tests in selected coreholes were used to arrive at a population of measured hydraulic conductivity values for the Mancos Shale. The sample population was then used to develop an estimate of the geometric-mean hydraulic conductivity for the layers comprising the Mancos Shale. Measured values of hydraulic conductivity in the Mancos Shale at the Crescent Junction Disposal Site are similar to the measured values of hydraulic conductivity in the Mancos Shale at the Grand Junction Disposal Site (DOE 1991, Calculations GRJ-08-89-14-01, Sheet 9; GRJ-12-89-12-06-00b, Sheet 52/58) and to those reported for the Mancos Shale near the Green River, Utah, Landfill site (Infill Companies, 2003, p. 17).

Vertical hydraulic conductivity values presented in Table 1 are strongly biased toward the high end of the potential range because 20 of the packer tests resulted in no-flow conditions. If more precise measurements were made of the hydraulic conductivity the true hydraulic conductivity values would lower the calculated geometric mean hydraulic conductivity. In more precise studies made by the U.S. Geological Survey of the Mancos Shale and its equivalent the Pierre Shale, the vertical hydraulic conductivity ranged from 1.0×10^{-8} to 1.9×10^{-12} cm/s (Frenzel and Lyford, 1982, p. 17 and pp. 30–31; Bredehoeft et al., 1983, pp. 28–29). Based on these literature results, the true geometric mean hydraulic conductivity at the Crescent Junction Site could be 0.5 to 2 orders of magnitude lower than the one used in this calculation. Recomputing the travel time calculation with the lower mean hydraulic conductivities would yield a travel time ranging from 23,500 to 11,750,000 years. Therefore, a hydraulic conductivity value of 2.3×10^{-8} cm/sec yields a conservative (minimum) range of travel times.

(3) Effective porosity

Using the conservatively low literature-derived values of 0.005 to 0.05 for effective porosity also leads to a conservative approximation of travel time. Effective porosity values vary over a relatively limited range and consequently have less effect on potential error propagation. The minimum literature value for effective porosity value of 0.005 would embody a reasonable measure of conservatism.

Conclusion and Recommendations:

Hydraulic head measurements obtained from the Mancos Shale represent perched, connate ground water without any connection to the Dakota aquifer. The absolute age of the connate ground water has not been determined for the Crescent Junction Site; however, Briant Kimball (personal communication, April 11, 2006) states, “any brine in Mancos would be older than the ages that could be determined by carbon-14”. This would signify that the minimum age of the brine is late Pleistocene, which provides a credible basis to the notion that the vertical travel times calculated herein are a conservative estimate.

With the vertical travel time between the Mancos Shale and the Dakota aquifer estimated to range from 3,330 to 33,300 years, the construction of the Crescent Junction Disposal Cell would pose no adverse impact on ground water resources in the area.

Computer Source:

Not applicable.

References:

Bredehoeft, J.D., C.E. Neuzil, and P.C.D. Milly, 1983. *Regional Flow in the Dakota Aquifer: A Study of the Role of Confining Layers*, U.S. Geological Survey Water-Supply Paper 2237.

DOE (U.S. Department of Energy), 1991. *Remedial Action Plan and Site Design for Stabilization of the Inactive Uranium Mill Tailings Site at Grand Junction, Colorado*, Appendix A to Attachment 3, Vols. 1 and 2, UMTRA-DOE/AL-050505.000.

Domenico, P.A., and F.W. Schwartz, 1990. *Physical and Chemical Hydrogeology*, John Wiley and Sons, New York.

Freethey, G.W., and G.E. Cordy, 1991. *Geohydrology of Mesozoic Rocks in the Upper Colorado River Basin in Arizona, Colorado, New Mexico, Utah, and Wyoming, Excluding the San Juan Basin*, U.S. Geological Survey Professional Paper 1411-C, 6 Plates.

Frenzel, P.F., and F.P. Lyford, 1982. *Estimates of Vertical Hydraulic Conductivity and Regional Ground Water Flow Rates in Rocks of Jurassic and Cretaceous Age, San Juan Basin, New Mexico and Colorado*, U.S. Geological Survey Water-Resources Investigations Report 82-4015.

Infill Companies, 2003. *Class V Landfill Application*, prepared for Green River Landfill, LLC, April.

Kimball, Briant, A., April 11, 2006. Personal Communication, U. S. Geological Survey, Salt Lake City, Utah, office.

Nuclear Regulatory Commission (NRC), 1993. *Final Standard Review Plan for the Review and Remedial Action of Inactive Mill Tailings Sites under Title I of the Uranium Mill Tailings Radiation Control Act, Revision 1*.

End of current text

U.S. Department of Energy—Grand Junction, Colorado

Calculation Cover Sheet

Calc. No.: MOA-02-02-2007-3-01-00
Doc. No.: X0203900

Discipline: Geochemical
Properties

No. of Sheets: 6

Location: Attachment 3, Appendix F

Project: Moab UMTRA Project

Site: Crescent Junction Disposal Site

Feature: Geochemical Characterization – Radiocarbon Age Determinations for Ground Water Samples
Obtained From Wells 0203 and 0208

Sources of Data:

Radiocarbon age determinations for ground water samples obtained from wells 0203 and 0208.

Sources of Formulae and References:

Clark, I.D., and P. Fritz, 1997. *Environmental Isotopes in Hydrogeology*, CRC Press, Boca Raton, Florida.

Preliminary Calc.

Final Calc.

Supersedes Calc. No.

Author:

Name

Mal Kenney

Date

5-31-07

Checked by:

Name

J. Cummins

Date

5/31/07

Approved by:

Name

Kend Kerp

Date

5/31/07

Name

Chloe

Date

31 May 07

Name

Barry Godlight

Date

31 May 07

Name

Dufetz

Date

MAY 31, 07

No text for this page

Problem Statement:

Preliminary site selection performed jointly by the U.S. Department of Energy (DOE) and the Contractor, S.M. Stoller Corporation, has identified a 2,300-acre withdrawal area in the Crescent Flat area just northeast of Crescent Junction, Utah, as a possible site for final disposal of the Moab uranium mill tailings. The proposed disposal cell would cover approximately 250 acres. Based on the preliminary site-selection process, the suitability of the Crescent Junction Disposal Site is being evaluated from several technical aspects, including geomorphic, geologic, hydrologic, seismic, geochemical, and geotechnical. The objective of this calculation is to present the radiocarbon-estimated age of the ground water, found in two of the 300-foot (ft) coreholes (wells) underlying the Crescent Junction Disposal Site.

Ground water beneath the Crescent Junction Disposal Site occurs in several, but not all, of the 10 coreholes that were advanced to a depth of 300 ft. The ground water is briny in composition and, because of its limited spatial extent, is hypothesized to be very old water and effectively "trapped" in the Mancos Shale. The radiocarbon age dating was performed in order to test this hypothesis.

These data will be incorporated into Attachment 3 of the *Remedial Action Plan and Site Design for Stabilization of Moab Title I Uranium Mill Tailings at Crescent Junction, Utah, Site* (RAP) and summarized in the *Remedial Action Selection* (RAS) report for the Moab Site.

Method of Solution:

General procedures for sample collection and sample preparation were obtained from Clark and Fritz (1997). According to these procedures, a sufficient sample volume is collected to yield a minimum of 3 grams (g) of pure carbon from each sample. Wells 0203 and 0208 at the Crescent Junction Disposal Site were selected for radiocarbon age determination primarily because ground water from these wells was known to contain the highest alkalinity concentrations measured at the site, and secondarily because they could readily yield the volume of water required for a radiocarbon sample. Highly elevated alkalinity concentrations are important to radiocarbon sampling because the carbon required for the analysis is contained in the dissolved carbonate and bicarbonate species in the water sample.

Prior to sample collection, the required sample volume was estimated from the measured alkalinity of the ground water and the laboratory requirement of a minimum of 3 g of pure carbon for the analysis. The volume of ground water required for an adequate sample is obtained by dividing the 3 g pure carbon required by the laboratory by the carbon concentration in the water sample. In wells 0203 and 0208, the total alkalinity (expressed as CaCO_3) is known to be 1,400 milligrams per liter (mg/L) and 1,700 mg/L, respectively. Therefore, the sample-volume calculation indicates that a minimum volume of 17.9 liters (L) and 14.7 L would be required from wells 0203 and 0208, respectively. Details of the sample volume calculations for samples from wells 0203 and 0208 are presented in Appendix A of this calculation.

Ground water at the Crescent Junction Site was assumed to be very old and, consequently, isolated from atmospheric sources of so-called *modern carbon*. To control the introduction of modern carbon into the ground water sample, all sample collection, sample transfer, and sample handling operations were done under a blanket of nitrogen gas. The nitrogen gas was introduced above the water column to completely displace all atmospheric gas from the well bore. Reintroduction of atmospheric gas into the headspace of the well was prevented during the traditional ground water purging step by continuously passing nitrogen gas into the well bore. The nitrogen gas was slowly injected in a "bottom-up" direction through a hose that extended almost to the static water level.

Boyle's Law was used to calculate the volume of nitrogen gas required to displace all the atmospheric gas from the headspace in the well. Boyle's Law describes the change in gas volume in response to pressure. Measurements taken at the pressure regulator were used to ensure that a sufficient volume of nitrogen gas was injected into the headspace of the well. Following the purge, when the water level began to recover, the flow of nitrogen gas was shut off because the recovering water level, acting as a piston, would force the nitrogen gas out from the borehole and prevent atmospheric gas from reentering the borehole.

An example of the Boyle's Law calculation used to estimate the volume of gas required to displace atmospheric gas from the corehole is shown next:

$$P_1V_1 = P_2V_2$$

Where

P_1 = pressure of nitrogen in cylinder (pounds per square inch [psi])

V_1 = volume of cylinder (2.5 cubic feet [ft³])

P_2 = atmospheric pressure (14.7 psi)

V_2 = volume of air-filled portion of borehole (ft³)

$$P_1 = (P_2V_2) / V_1$$

$$P_1 = (14.7 \text{ psi} \times 15 \text{ ft}^3) / 2.5 \text{ ft}^3$$

$$P_1 = 88 \text{ psi}$$

The quantity P_1 indicates that a pressure of 88 psi is required to evacuate atmospheric gas from the corehole when the water level in corehole 0208 is 185 ft below ground surface. Therefore, 200 psi was injected into the corehole to evacuate a minimum of 2 corehole volumes. Similar computations are used to show that approximately 110 psi is injected to evacuate 2 borehole volumes when the water level in corehole 0203 is 110 ft below the surface. The nitrogen hose was lowered to just above the water level, and the nitrogen gas was injected using a regulator setting of 20 psi to slowly displace the atmospheric gas from the well prior to the purge.

Nitrogen was also injected during the traditional ground water purge step. The injection rate of nitrogen gas into the borehole was designed to exceed the displacement of the water level in the well and prevent the "pulling" of atmospheric gas into the corehole. Each well was equipped with a dedicated 5-gallon-per-minute (gpm)-capacity pump. A pumping rate of 5 gpm is equivalent to 0.67 ft³ per minute. Thus, according to Boyle's Law,

$$P_1 = (P_2V_2) / V_1$$

$$P_1 = (14.7 \text{ psi} \times 0.67 \text{ ft}^3) / 2.5 \text{ ft}^3$$

$$P_1 = 3.9 \text{ psi}$$

The quantity P_1 signifies that 3.9 psi per minute is required to eliminate the pulling of atmospheric gas into the corehole during the traditional ground water purge. During the radiocarbon ground water sampling at the Crescent Junction Disposal Site, the injection rate of nitrogen gas during sampling was maintained at 20 psi.

Nitrogen gas was also used to purge atmospheric gas from the sample containers. After the sample containers were filled with the required sample volume they were transported to the Environmental Sciences Laboratory to precipitate the available carbonate in the sample to BaCO₃. This was accomplished by adding approximately 30 milliliters of carbonate-free NaOH to the sample in order to raise the pH above 11. The amount of Ba⁺², added as BaCl₂•2H₂O, required to precipitate all of the carbonate must be sufficient to also precipitate all SO₄. As presented in Appendix A of this calculation, the amounts of BaCl₂•2H₂O required for wells 0203 and 0208 were 401 g and 421 g, respectively. After the chemicals were added, the sample containers were left in the laboratory for the precipitated carbonate to settle to the bottom.

The supernatant was then drained off of the precipitate using the bottom spigot on the sample container. To avoid introducing atmospheric carbon into the sample container, a rubber bung equipped with an Ascarite (CO₂-absorbing compound) and Drierite (moisture-absorbing compound) trap was inserted into the top of the sample container. The remaining sludge was transferred into nitrogen-filled, 1-L Nalgene narrow-mouth containers and packaged for sample shipment.

All samples were analyzed at GEOCHRON Laboratories, Cambridge, MA. Analytical results from the laboratory are presented in Appendix B of this calculation.

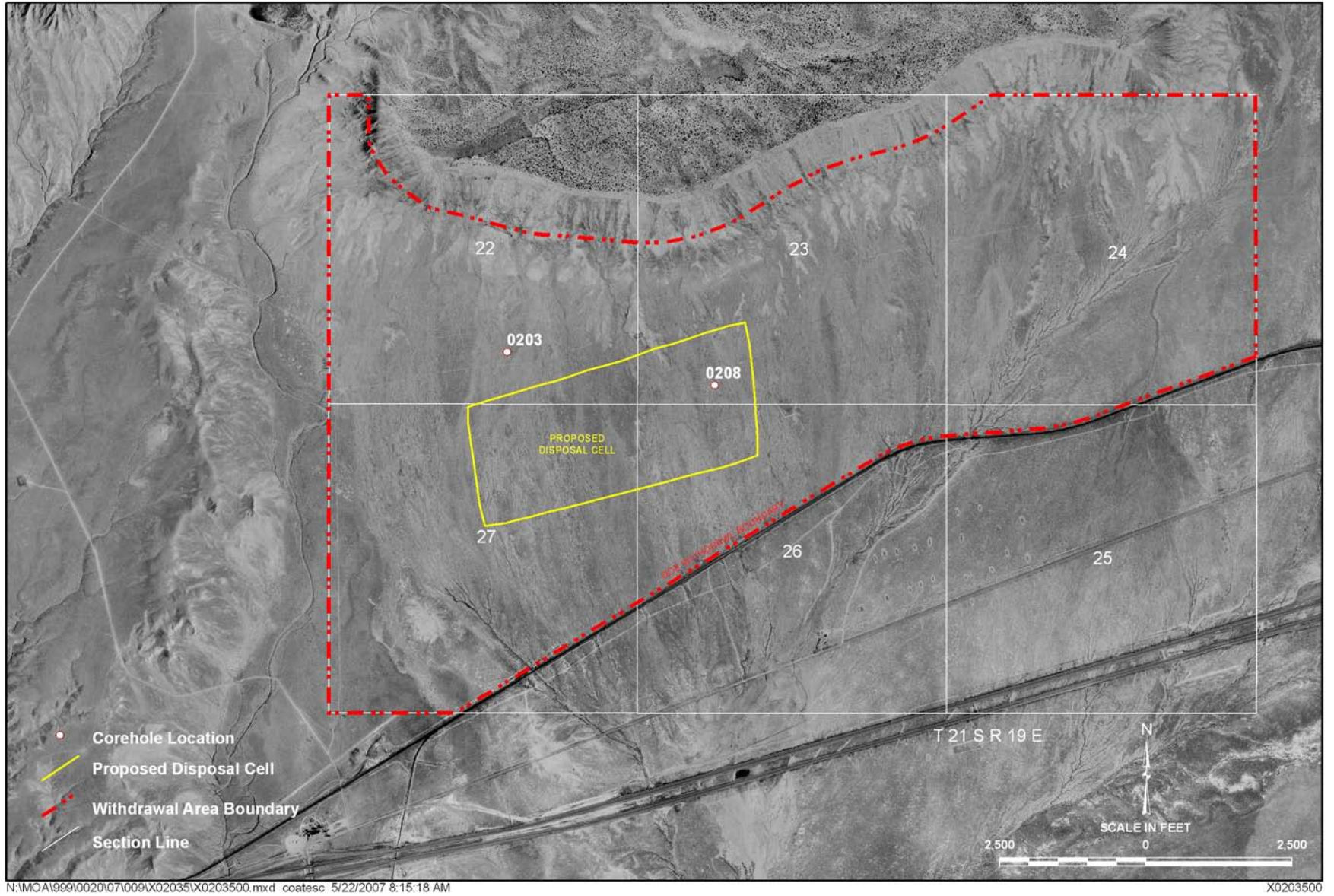

Figure 1. Location of Wells 0203 and 0208 at the Crescent Junction Disposal Site

Assumptions:

- Ground water at the Crescent Junction Site is isolated from atmospheric sources of so-called modern carbon.
- Samples drawn from wells 0203 and 0208 are representative of site conditions. Water samples from other wells at the site will yield similar radiocarbon ages to those obtained at 0203 and 0208.
- Applying a blanket of nitrogen gas on the ground water sample effectively excludes all modern-carbon contamination.

Calculation:

Laboratory results are presented in Appendix B. Table 1 presents a summary of the age dates.

Table 1. Summary of Radiocarbon Age Determination

Corehole	Sample Name	¹⁴ C Years (Before Present ¹)
0203	NFA256	≥41,090
	NFA257	38,650 ⁺⁷⁴⁵⁰ -3800
	NFA258	≥44,560
0208	NFA259	≥40,180
	NFA260	≥40,180
	NFA261	≥38,540

¹The age before present is referenced to the year 1950.

Discussion:

Radiocarbon sampling methods appear to have been successful in excluding modern carbon from the ground water samples; however, minor contamination with modern carbon may be the cause of the error bands assigned to the result for sample NFA257. Based on the preponderance of sample results, the age of the ground water beneath the site appears to be at least 40,000 years before present.

Conclusion and Recommendations:

Ground water age determination at the Crescent Junction Disposal Site indicates that the briny ground water beneath the site is at least as old as late Pleistocene. This determination provides supporting evidence that travel times for vertical (and horizontal) ground water movement would be very long, as predicted in the "Hydrologic Characterization-Vertical Travel Time to Uppermost (Dakota) Aquifer" calculation (RAP Attachment 3, Appendix E). Based on these radiocarbon ages, the shallow ground water at the site would pose no adverse risk to deeper water resources.

Computer Source: Not Applicable

Appendix A
Calculation Sheets

Stoller

7-13-06

JOB NAME: Crescent Jct. ¹⁴C determination

PREPARED: M. Kautsky REVIEWED: _____

SHEET NO.: 1 OF _____

1.0
 Prepare Carbon-free NaOH solution
 15N NaOH solution - 5mg/liter inj. to prep. all CO₂.

2.0
 Sample wells: 202, 203, & 208

well	SO ₄ (mg/l)	Total Alkalinity HCO₃⁻ CaCO ₃ (mg/L)
202	425	430
203	4500	1400
208	5900	1700

3.0
 Need 3g C.

Well Groundwater sample size required to yield 3g C is...

202 $\text{mg C/liter} = \left(\frac{12 \text{ mg C}}{100 \text{ mg CaCO}_3} \right) \left(\frac{430 \text{ mg CaCO}_3}{L} \right) = 51.6 \text{ mg C/liter}$

$$\frac{3 \text{ g C}}{0.0516 \text{ g C/liter}} = 58 \text{ liters from well 202}$$

Because 58L won't fit in 25L sample container, don't sample well 202

Well 203 $\text{mg C/l} = \left(\frac{12 \text{ mg C}}{100 \text{ mg CaCO}_3} \right) \left(\frac{1400 \text{ mg CaCO}_3}{L} \right) = 168 \text{ mg C/liter}$

$$\frac{3 \text{ g C}}{0.168 \text{ g C/l}} = 17.9 \text{ liters from well 203}$$

Well 204 & 208 $\frac{\text{mg C}}{L} = \left(\frac{12 \text{ mg C}}{100 \text{ mg CaCO}_3} \right) \left(\frac{1700 \text{ mg CaCO}_3}{L} \right) = 204 \text{ mg C/l}$

$$\therefore \frac{(3 \text{ g C})}{(0.204 \text{ g C/L})} = 14.7 \text{ L from well 204 & 208}$$

Calculation Sheet 1 showing how sample volumes are estimated from alkalinity for coreholes 0202, 0203, and 0208.

Stoller

7-13-06

JOB NAME: Crescent Jet ¹⁴C determination

PREPARED: M. Koutsky REVIEWED:

SHEET NO.: 2 OF

Well 203

Amount of $BaCl_2$ required to precipitate all dissolved carbon
Assume all carbon species are in the form CO_3^{2-}

Amount of $BaCl_2$ should be in excess to precipitate both $BaCO_3$ and $BaSO_4$ *

Moles of CO_3^{2-} will be estimated from analytical results from previous groundwater samples.
Moles of SO_4^{2-} will be estimated from analytical results from previous groundwater samples.

Amount of SO_4^{2-} in well 203

$$17.9 \text{ L} \left(\frac{4.5 \text{ g } SO_4^{2-}}{\text{L}} \right) \left(\frac{1 \text{ mole } SO_4^{2-}}{96 \text{ g } SO_4^{2-}} \right) = 0.84 \text{ moles } SO_4^{2-}$$

Amount of $CaCO_3$ in well 203

$$17.9 \text{ L} \left(\frac{1.4 \text{ g } CaCO_3}{\text{L}} \right) \left(\frac{1 \text{ mole } CaCO_3}{100 \text{ g } CaCO_3} \right) = 0.25 \text{ moles } CaCO_3 \\ (= 0.25 \text{ moles } CO_3^{2-})$$

$$\text{Moles } SO_4^{2-} + \text{moles } CO_3^{2-} = 0.84 + 0.25 = 1.1 \text{ moles}$$

$$\text{Moles } BaCl_2 \text{ req'd} = 1.1$$

$$1.1 \text{ moles } BaCl_2 = 1.1 \text{ moles } BaCl_2 \cdot 2H_2O$$

unit	unit	extended.
gfw Ba	= 137.3	= 137.3
gfw Cl	= 35.4 g	= 70.8 g
gfw H	= 1.0 g	= 4 g
gfw O	= 16.0 g	= 32 g
Total gfw		= 243.8 g
$BaCl_2 \cdot 2H_2O$		

$$\text{Minimum mass of } BaCl_2 \cdot 2H_2O \text{ req'd} = 1.1 (243.8 \text{ g}) = 263 \text{ g}$$

$$* 1.5 \text{ excess } (263 \text{ g } BaCl_2 \cdot 2H_2O) = 401 \text{ g } BaCl_2 \cdot 2H_2O$$

Calculation Sheet 2 showing the determination of amount of $BaCl_2 \cdot 2H_2O$, required to precipitate all of the carbonate and sulfate from water in well 0203.

Stoller

7-13-06

JOB NAME: General Test ¹⁴C determination

PREPARED: M. Kautsky REVIEWED: _____

SHEET NO. 3 OF _____

²⁰⁸
Well ~~204~~Amount of BaCl₂ req'd to precip all dissolved carbon ... (cont)Amount SO₄²⁻ in well ²⁰⁸~~204~~

$$14.7 \text{ L} \left(\frac{5.9 \text{ mg SO}_4^{2-}}{\text{L}} \right) \left(\frac{1 \text{ mole SO}_4^{2-}}{96 \text{ g SO}_4^{2-}} \right) = \frac{0.903}{0.006} \text{ moles SO}_4^{2-}$$

Amount CaCO₃ in well ²⁰⁸~~204~~

$$14.7 \text{ L} \left(\frac{1.7 \text{ mg CaCO}_3}{\text{L}} \right) \left(\frac{1 \text{ mole CaCO}_3}{100 \text{ g CaCO}_3} \right) = \frac{0.25}{0.006} \text{ moles CaCO}_3$$

(= 0.0025 moles CO₃²⁻)

$$\text{moles SO}_4^{2-} + \text{moles CO}_3^{2-} = \frac{0.903}{0.006} + \frac{0.25}{0.006} = 0.129 \text{ } 1.155$$

$$\text{moles BaCl}_2 \cdot 2\text{H}_2\text{O} = 0.129 \text{ } 1.155$$

$$\text{GFW BaCl}_2 \cdot 2\text{H}_2\text{O} = 243.8 \text{ g}$$

$$\text{Minimum mass BaCl}_2 \cdot 2\text{H}_2\text{O req'd} = \left(\frac{1.155}{\text{mole}} \right) \left(\frac{243.8 \text{ g}}{\text{mole}} \right) = \frac{281 \text{ g}}{37.3 \text{ g}} \text{ BaCl}_2 \cdot 2\text{H}_2\text{O}$$

$$1.5 \text{ excess} \left(\frac{281}{37.3} \text{ g BaCl}_2 \cdot 2\text{H}_2\text{O} \right) = \frac{421}{47} \text{ g BaCl}_2 \cdot 2\text{H}_2\text{O}$$

Calculation Sheet 3 showing the determination of amount of BaCl₂•2H₂O, required to precipitate all of the carbonate and sulfate from water in well 0208.

Appendix B

Laboratory Results of Radiocarbon Sampling

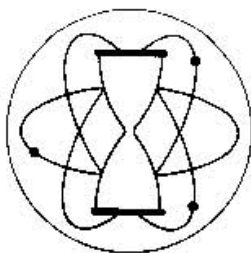

GEOCHRON LABORATORIES

a division of Krueger Enterprises, Inc.

711 Concord Avenue ♦ Cambridge, Massachusetts 02138-1002 ♦ USA
t (617) 876-3691 f (617) 661-0148 www.geochronlabs.com

RADIOCARBON AGE DETERMINATION

REPORT OF ANALYTICAL WORK

Our Sample No. **GX-32612**

Date Received: 07/31/2006

Your Reference: PO # 2989

Date Reported: 08/09/2006

Submitted by: Mark Kautsky
S.M. Stoller Corp.
2597 B ¼ Road
Grand Junction, CO 81503

Sample Name: **Crescent Junction NFA 256**

AGE = **≥ 41090 ¹⁴C years BP (¹³C corrected)**
≤ 0.50 % of the modern (1950) ¹⁴C activity

Description: Sample of ground water

Pretreatment: The barium salt precipitate was rapidly vacuum filtered and immediately hydrolyzed, under vacuum, to recover carbon dioxide from the barium carbonates for the analysis. ¹³C analysis was made from a small portion of the same evolved gas.

Comments:

$\delta^{13}\text{C}_{\text{PDB}}$ = **-1.6 ‰**

Notes: This date is based upon the Libby half life (5570 years) for ¹⁴C. The error is +/- 1 s as judged by the analytical data alone. Our modern standard is 95% of the activity of N.B.S. Oxalic Acid.

The age is referenced to the year A.D. 1950.

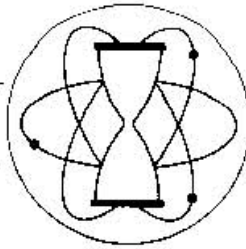

GEOCHRON LABORATORIES

a division of Krueger Enterprises, Inc.

711 Concord Avenue ♦ Cambridge, Massachusetts 02138-1002 ♦ USA
t (617) 876-3691 f (617) 661-0148 www.geochronlabs.com

RADIOCARBON AGE DETERMINATION

REPORT OF ANALYTICAL WORK

Our Sample No. **GX-32613**

Date Received: 07/31/2006

Your Reference: PO # 2989

Date Reported: 08/09/2006

Submitted by: Mark Kautsky
S.M. Stoller Corp.
2597 B ¾ Road
Grand Junction, CO 81503

Sample Name: **Crescent Junction NFA 257**

AGE = 38650^{+7450}_{-3800} ¹⁴C years BP (¹³C corrected)
0.81 ± 0.49 % of the modern (1950) ¹⁴C activity

Description: Sample of ground water

Pretreatment: The barium salt precipitate was rapidly vacuum filtered and immediately hydrolyzed, under vacuum, to recover carbon dioxide from the barium carbonates for the analysis. ¹³C analysis was made from a small portion of the same evolved gas.

Comments:

$\delta^{13}\text{C}_{\text{POB}}$ = **-3.5 ‰**

Notes: This date is based upon the Libby half life (5570 years) for ¹⁴C. The error is +/- 1 s as judged by the analytical data alone. Our modern standard is 95% of the activity of N.B.S. Oxalic Acid.

The age is referenced to the year A.D. 1950.

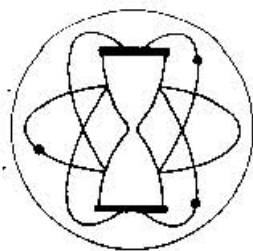

GEOCHRON LABORATORIES

a division of Krueger Enterprises, Inc.

711 Concord Avenue ♦ Cambridge, Massachusetts 02138-1002 ♦ USA
t (617) 876-3691 f (617) 661-0148 www.geochronlabs.com

RADIOCARBON AGE DETERMINATION

REPORT OF ANALYTICAL WORK

Our Sample No. **GX-32614**

Date Received: 07/31/2006

Your Reference: PO # 2989

Date Reported: 08/09/2006

Submitted by: Mark Kautsky
S.M. Stoller Corp.
2597 B ¾ Road
Grand Junction, CO 81503

Sample Name: **Crescent Junction NFA 258**

AGE = ≥ 44560 ¹⁴C years BP (¹³C corrected)
 ≤ 0.42 % of the modern (1950) ¹⁴C activity

Description: Sample of ground water

Pretreatment: The barium salt precipitate was rapidly vacuum filtered and immediately hydrolyzed, under vacuum, to recover carbon dioxide from the barium carbonates for the analysis. ¹³C analysis was made from a small portion of the same evolved gas.

Comments:

$\delta^{13}\text{C}_{\text{PDB}}$ = -1.5 ‰

Notes: This date is based upon the Libby half life (5570 years) for ¹⁴C. The error is +/- 1 s as judged by the analytical data alone. Our modern standard is 95% of the activity of N.B.S. Oxalic Acid.

The age is referenced to the year A.D. 1950.

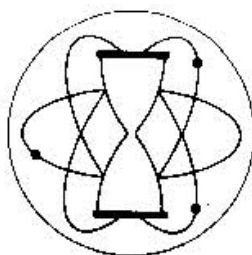

GEOCHRON LABORATORIES

a division of Krueger Enterprises, Inc.

711 Concord Avenue + Cambridge, Massachusetts 02138-1002 + USA
t (617) 876-3691 f (617) 661-0148 www.geochronlabs.com

RADIOCARBON AGE DETERMINATION

REPORT OF ANALYTICAL WORK

Our Sample No. **GX-32615**

Date Received: 07/31/2006

Your Reference: PO # 2989

Date Reported: 08/09/2006

Submitted by: Mark Kautsky
S.M. Stoller Corp.
2597 B ¾ Road
Grand Junction, CO 81503

Sample Name: **Crescent Junction NFA 259**

AGE = **≥ 40180 ¹⁴C years BP (¹³C corrected)**
≤ 0.51 % of the modern (1950) ¹⁴C activity

Description: Sample of ground water

Pretreatment: The barium salt precipitate was rapidly vacuum filtered and immediately hydrolyzed, under vacuum, to recover carbon dioxide from the barium carbonates for the analysis. ¹³C analysis was made from a small portion of the same evolved gas.

Comments:

$\delta^{13}\text{C}_{\text{PDB}} = -2.3 \text{ ‰}$

Notes: This date is based upon the Libby half life (5570 years) for ¹⁴C. The error is +/- 1 s as judged by the analytical data alone. Our modern standard is 95% of the activity of N.B.S. Oxalic Acid.

The age is referenced to the year A.D. 1950.

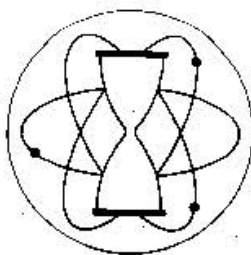

GEOCHRON LABORATORIES

a division of Krueger Enterprises, Inc.

711 Concord Avenue + Cambridge, Massachusetts 02138-1002 + USA
t (617) 876-3691 f (617) 661-0148 www.geochronlabs.com

RADIOCARBON AGE DETERMINATION

REPORT OF ANALYTICAL WORK

Our Sample No. **GX-32616**

Date Received: 07/31/2006

Your Reference: PO # 2989

Date Reported: 08/09/2006

Submitted by: Mark Kautsky
S.M. Stoller Corp.
2597 B ¼ Road
Grand Junction, CO 81503

Sample Name: **Crescent Junction NFA 260**

AGE = **≥ 40180 ¹⁴C years BP (¹³C corrected)**
≤ 0.51 % of the modern (1950) ¹⁴C activity

Description: Sample of ground water

Pretreatment: The barium salt precipitate was rapidly vacuum filtered and immediately hydrolyzed, under vacuum, to recover carbon dioxide from the barium carbonates for the analysis. ¹³C analysis was made from a small portion of the same evolved gas.

Comments:

$\delta^{13}\text{C}_{\text{PDB}}$ = **-2.7 ‰**

Notes: This date is based upon the Libby half life (5570 years) for ¹⁴C. The error is +/- 1 s as judged by the analytical data alone. Our modern standard is 95% of the activity of N.B.S. Oxalic Acid.

The age is referenced to the year A.D. 1950.

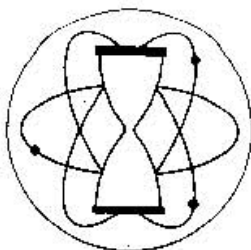

GEOCHRON LABORATORIES

a division of Krueger Enterprises, Inc.

711 Concord Avenue + Cambridge, Massachusetts 02138-1002 + USA
t (617) 876-3691 f (617) 661-0148 www.geochronlabs.com

RADIOCARBON AGE DETERMINATION

REPORT OF ANALYTICAL WORK

Our Sample No. **GX-32617**

Date Received: 07/31/2006

Your Reference: PO # 2989

Date Reported: 08/09/2006

Submitted by: Mark Kautsky
S.M. Stoller Corp.
2597 B 3/4 Road
Grand Junction, CO 81503

Sample Name: **Crescent Junction NFA 261**

AGE = ≥ 38540 ^{14}C years BP (^{13}C corrected)
 ≤ 0.53 % of the modern (1950) ^{14}C activity

Description: Sample of ground water

Pretreatment: The barium salt precipitate was rapidly vacuum filtered and immediately hydrolyzed, under vacuum, to recover carbon dioxide from the barium carbonates for the analysis. ^{13}C analysis was made from a small portion of the same evolved gas.

Comments:

$\delta^{13}\text{C}_{\text{PDB}}$ = -1.7 ‰

Notes: This date is based upon the Libby half life (5570 years) for ^{14}C . The error is ± 1 s as judged by the analytical data alone. Our modern standard is 95% of the activity of N.B.S. Oxalic Acid.

The age is referenced to the year A.D. 1950.

NFA 256

Project Crescent Junction
 Site _____ Location 0203 - Sample 1
 Date 7-28-06 Time _____ Matrix GW
 Interval 1m Sampler _____
 Comments _____

Analyte(s)	Container Type	Number Collected	Filtered	Preservative
¹⁴ C	25-L canby	2	Y	No
	1 L HDPE			

NFA 257

Project Crescent Junction

Site 8 Location 0203 - Sample 2

Date 7-26-06 Time _____ Matrix _____
AM

Interval _____ Sampler _____

Comments _____

Analyte(s)	Container Type	Number Collected	Filtered	Preservative
<i>14C</i>	<i>1 L HDPE</i>	<i>2</i>	<i>Y</i>	<i>No</i>

GJ 1854
7/2004

White copy to Project Manager; canary to laboratory; pink remains in ticket book

NFA 258

Project Crescent Junction

Site _____ Location 0203 - Sample 3

Date 7-28-06 Time _____ Matrix GW

Interval _____ Sampler _____

Comments _____

Analyte(s)	Container Type	Number Collected	Filtered	Preservative
VAC	1L HOPE	2	Y	No

GJ 1854
7/2004

White copy to Project Manager; canary to laboratory; pink remains in ticket book.

NFA 259

Project Crescent Junction

Site _____ Location 0208-Sample 1

Date 7-28-06 Time _____ Matrix GW

Interval _____ Sampler _____

Comments _____

Analyte(s)	Container Type	Number Collected	Filtered	Preservative
<u>14C</u>	<u>1L HDPE</u>	<u>2</u>	<u>y</u>	<u>No</u>

GJ 1854
7/2004
White copy to Project Manager; canary to laboratory; pink remains in ticket book

NFA 260

Project Crescent Junction

Site _____ Location 0208 Sample 2

Date 7-28-06 Time _____ Matrix GW

Interval _____ Sampler _____

Comments _____

Analyte(s)	Container Type	Number Collected	Filtered	Preservative
<u>14C</u>	<u>1L HDPE</u>	<u>2</u>	<u>Y</u>	<u>NO</u>

CJ 1854
7/2004

White copy to Project Manager; canary to laboratory; pink remains in ticket book.

NFA 261

Project Crescent Junction

Site _____ Location 0208 Sample 3

Date 7-28-06 Time _____ Matrix GW

Interval _____ Sampler _____

Comments _____

Analyte(s)	Container Type	Number Collected	Filtered	Preservative
¹⁴ C	¹² HDPE	2	Y	No

GJ 1854
7/2004

White copy to Project Manager; canary to laboratory; pink remains in ticket book

U.S. Department of Energy—Grand Junction, Colorado

Calculation Cover Sheet

Calc. No.: MOA-02-06-2007-2-14-00 Discipline: Hydrology No. of Sheets: 12
 Doc. No.: X0173700

Location: Attachment 3, Appendix G

Project: Moab UMTRA Project

Site: Crescent Junction Disposal Site

Feature: Hydrologic Characterization – Lateral Spreading of Leachate

Sources of Data:

RAP calculations as referenced in text.

Sources of Formulae and References:

Bear, J. 1979. *Hydraulics of Groundwater*, McGraw-Hill, Inc.

Carslaw, H.S., and J.C. Jaeger, 1986. *Conduction of Heat in Solids*, 2nd Edition, Clarendon Press, Oxford.

Hantush, M.S., 1967. *Growth and Decay of Groundwater Mounds in Response to Uniform Percolation*, Water Resources Research, 3(1), pp. 227–234.

Lambe, W.T., and R.V. Whitman, 1969. *Soil Mechanics*, John Wiley and Sons, New York.

NRC, 1993. *Final Standard Review Plan for the Review and Remedial Action of Inactive Mill Tailings Sites Under Title I of the Uranium Mill Tailings Remediation Control Act*, Revision 1, June 1993.

Walvoord, M.A., and B.R. Scanlon, 2004. "Hydrologic Processes in Deep Vadose Zones in Interdrainage Arid Environments," in Hogan, J.F., F.M. Phillips, and B.R. Scanlon, Editors, *Groundwater Recharge in a Desert Environment: The Southwestern United States*, American Geophysical Union Water Science Application 9.

Preliminary Calc. Final Calc. X Supersedes Calc. No.

Author:	<u>Macl Kennedy</u> 6-20-07	Checked by:	<u>Alm Strachan</u> 20 June 07
	Name Date		Name Date
Approved by:	<u>John E. Karp</u> KEN KARP		<u>Dave Peterson</u> 6-20-07
	Name Date		Name Date
			<u>DE Cunningham</u> 6-20-07
			Name Date
			<u>DR Metz</u> 6-21-2007
			Name Date

No text for this page

Problem Statement:

Preliminary site selection performed jointly by the U.S. Department of Energy (DOE) and the Contractor has identified a 2,300-acre withdrawal area in the Crescent Flat area just northeast of Crescent Junction, Utah, as a possible site for a final disposal cell for the Moab uranium mill tailings. The proposed disposal cell would cover approximately 250 acres. Based on the preliminary site-selection process, the suitability of the Crescent Junction Disposal Site is being evaluated from several technical aspects, including geomorphic, geologic, hydrologic, seismic, geochemical, and geotechnical. The objective of this calculation set is to examine potential scenarios in which tailings-derived leachate could spread laterally in the weathered Mancos Shale at the base of the disposal cell prior to infiltrating into the unweathered Mancos Shale.

Conclusions from this calculation will be incorporated into Attachment 3 (Ground Water Hydrology) of the *Remedial Action Plan and Site Design for Stabilization of Moab Title I Uranium Mill Tailings at the Crescent Junction, Utah, Disposal Site (RAP)*, and summarized in the *Remedial Action Selection Report (RAS)* for the Moab Site.

Method of Solution:

Two solution methods are presented in this calculation: a method based on conservative assumptions, which is equivalent to assuming steady-state seepage rate of 1×10^{-7} centimeters per second (cm/s) (NRC 1993) through the tailings pile; and a method based on realistic assumptions, which is based on a seepage rate of less than 3.5×10^{-8} cm/s through the tailings pile. In this calculation, the method of conservative assumptions is shown to be protective of human health and environment; therefore, the method of realistic assumptions is also protective.

Conservative Assumptions:

Under steady-state conditions, the vertical percolation rate is conservatively assumed to be 1×10^{-7} cm/s (NRC 1993). The thickness of the weathered Mancos Shale is approximately 50 feet (ft). The leachate will migrate to the base the weathered Mancos Shale, becoming perched above the unweathered Mancos Shale, whose geometric mean hydraulic conductivity is 3.5×10^{-8} cm/s. With its downward movement impeded at the base of the weathered Mancos Shale, the leachate will gradually spread laterally away from the edge of the disposal cell. As it spreads, the leachate will be consumed by slow vertical leakage into the unweathered Mancos Shale. This calculation estimates the height to which the leachate might rise, both at the center and the edges of the disposal cell; it also estimates the length of lateral spreading of leachate from the edges and corners of the disposal cell.

- It is physically reasonable to combine the transient two-dimensional solution of Hantush (1967) (to obtain hydraulic head within the footprint of the disposal cell) with the steady-state one-dimensional solution of Bear (1979) (to obtain length of lateral spreading outside the footprint of the disposal cell).
- Beneath the footprint of the disposal cell, the unweathered bedrock is assumed to be impervious. (This assumption is a requirement of the Hantush [1967] solution; however, it calculates a thicker accumulation of leachate beneath the disposal cell because the actual hydraulic conductivity of the unweathered bedrock is greater than zero and would allow some vertical seepage to enter into the unweathered Mancos Shale.)
- Leachate mounding beneath the disposal cell is assumed to be symmetrical; consequently, the calculated height of the mound along any edge is identical to the mounding at the opposite edge. Similarly, the calculated height of mounding at any corner is identical to the mounding at any other corner.
- Outside the footprint of the disposal cell, the hydraulic conductivity of the unweathered bedrock is assumed to be uniformly equal to the geometric mean value of 3.5×10^{-8} cm/s (RAP Attachment 3, Appendix C, Table 1).
- Phreatic flow conditions with leakage can be used to describe the lateral-flow conditions that would exist beyond the envelope of the disposal cell.
- Leachate will spread laterally along the contact between weathered and unweathered Mancos Shale.

- The geometric mean hydraulic conductivity of 2.0×10^{-3} cm/s (2,059 feet per year [ft/yr]) (RAP Attachment 3, Appendix C, Table 1) of the weathered Mancos Shale is used as an upper-bounding estimate in this conservative calculation.
- The geometric mean **vertical** hydraulic conductivity of 1.2×10^{-4} cm/s (124 ft/yr) (RAP Attachment 3, Appendix A) is used as lower-bounding estimate in this conservative calculation.
- The thickness of the weathered zone in the Mancos Shale is approximately 50 ft.
- The weathered Mancos Shale is assumed to be homogeneous and isotropic.
- The shape of the disposal cell can be approximated by a rectangle having the dimensions 2,200 × 5,000 ft.
- The steady-state vertical percolation rate through the cover of the disposal cell is assumed to be 1×10^{-7} cm/s (NRC 1993).
- Natural recharge of (7.3×10^{-9} cm/s) through the undisturbed desert soils is a factor of 100 less than the average annual precipitation (7.3×10^{-7} cm/s; or 9.1 inch/yr).
- Because no ground water found in the weathered Mancos Shale during the site investigation, the initial hydraulic head in the weathered shale is assumed to be zero everywhere, (RAP Attachment 5, Appendixes A, B, and D).

Conservative Calculation:

This calculation is based on the conservative assumptions and solved by coupling two analytical solutions. The Hantush (1967) solution is used to estimate the height of a leachate mound that forms entirely within the weathered zone of the Mancos Shale beneath the footprint of the disposal cell. The mound heights are calculated for the following locations:

- Center of the disposal cell, where the leachate mound attains its maximum height (h_{max}): detailed calculation in Appendix A1 of this section, pages 2 through 5.
- Center of both the northern and southern edges of the disposal cell (h_0): detailed calculation in Appendix A2 of this section, pages 2 through 7.
- Center of both the eastern and western edges of the disposal cell (h_0): detailed calculation in Appendix A3 of this section, pages 2 through 7.
- Corners of the disposal cell (h_0): detailed calculation in Appendix A4 of this section, pages 2 through 7.

The calculated height of leachate, mounded at the perimeter of the disposal cell and known as the Hydraulic head, is obtained from the Hantush (1967) solution and given the symbol h_0 . Because the accumulation of leachate above the unweathered bedrock is a transient phenomenon, the Hantush (1967) method is used to calculate the height of the mound at three times: 10 years, 200 years, and 1,000 years.

The second analytical solution (Bear 1979; pp. 181–183; Equation 5-219) describes the length of lateral spreading that will propagate away from the edges and corners of the disposal cell. This steady-state solution assumes phreatic flow with downward leakage, and is used to describe the lateral spreading of leachate that will exist in the weathered Mancos Shale beyond the footprint of the disposal cell. Natural recharge through arid region desert soils of the southwestern United States is reported to range from approximately 0.01 to 0.1 mm/yr (3.17×10^{-11} to 3.17×10^{-10} cm/s) (Walvoord and Scanlon 2004). Per the assumptions developed for this calculation, the natural recharge rate is taken to be 1/100th of the average annual precipitation in the areas outside the footprint of the disposal cell, which is reasonable based on the fact that no free ground water is encountered above the depth of weathered bedrock at the site (RAP Attachment 5, Appendixes A, B, and D). The rate of vertical leakage through the unweathered Mancos Shale is a function of its geometric-mean hydraulic conductivity and the distance between the top of the unweathered Mancos Shale and the uppermost ground water. Based on depths to the uppermost ground water at the site, the thickness of the leaky layer (unweathered Mancos Shale) is taken to be 2,400 ft.

The Bear (1979) solutions are developed in the following locations:

- Beyond the northern and southern edges of the disposal cell (h_0): detailed calculation in Appendix A2 of this section, pp. 8–13.
- Beyond the eastern and western edges of the disposal cell (h_0): detailed calculation in Appendix A3 of this section, pp. 8–13.
- Beyond the corners of the disposal cell (h_0): detailed calculation in Appendix A4 of this section, pp. 8-13.

Hantush (1967) Solution

The maximum rise of the mound beneath the disposal cell occurs directly beneath the center of the disposal cell; the solution is obtained using Hantush (1967; equation 17):

$$h_{\max}^2 - h_i^2 = (2\omega / K)vtS^* \left(\frac{l}{\sqrt{4vt}}, \frac{a}{\sqrt{4vt}} \right) \quad (1)$$

where:

h_i = height of the water table that would have existed under natural conditions in the weathered Mancos Shale. In the case of the Crescent Junction Disposal Site, this value is zero, because there is no initial water table.

h_{\max} = height [L] of the water table at its maximum level, which forms at the center of the disposal cell.

ω = constant rate of seepage through the cover [L/T].

K = hydraulic conductivity [L/T].

$\nu = \frac{K\bar{b}}{\varepsilon}$, where ε = specific yield (dimensionless) and \bar{b} = constant of linearization (unity).

t = time since infiltration began (T).

$$S^* = \text{function. } S^*(\alpha, \beta) = \int_0^1 \operatorname{erf} \left\{ \frac{\alpha}{\sqrt{\tau}} \right\} \operatorname{erf} \left(\frac{\beta}{\sqrt{\tau}} \right) d\tau$$

Values of this function are tabularized in Hantush (1967). In some cases, Carslaw and Jaeger (1986, Appendix II, Table 1) was required to obtain the head solution to the analytical expression.

The height of the leachate mound is not as high along the edges of the disposal cell as it is at the center. Along the edges, the height of the leachate mound is computed using a Cartesian coordinate system to demarcate the locations where the head value is desired. Equation (2) is used to solve for the head distribution at three critical locations along the edges of the disposal cell:

$$h^2 - h_i^2 = \left(\frac{\omega}{2K} \right) (vt) \bullet \left[S^* \left(\frac{l+x}{\sqrt{4vt}}, \frac{a+y}{\sqrt{4vt}} \right) + S^* \left(\frac{l+x}{\sqrt{4vt}}, \frac{a-y}{\sqrt{4vt}} \right) + S^* \left(\frac{l-x}{\sqrt{4vt}}, \frac{a+y}{\sqrt{4vt}} \right) + S^* \left(\frac{l-x}{\sqrt{4vt}}, \frac{a-y}{\sqrt{4vt}} \right) \right] \quad (2)$$

Where l = half-length of Crescent Junction disposal cell (2,500 ft), a = half-width of Crescent Junction Disposal Cell (1,100 ft), x and y are distances along the x and y axes [with (0,0) located at the center of the disposal cell], and the remaining terms were defined above in equation (1). The three critical locations are at the midpoints of the western and eastern perimeters, the midpoints of the southern and northern perimeters, and at the corners of the disposal cell. Solutions to equations (1) and (2) are presented in Appendix A1 through A4 of this section.

Bear (1979) Solution

After obtaining the hydraulic head of the leachate mound along the perimeter of the disposal cell, equation 5-219 (Bear 1979; pp. 181-183) is used to compute the length of lateral spreading. The h_0 term in the Bear solution is obtained from the Hantush solutions (Equation 2 of this calculation) along the perimeter of the disposal cell. The length of spreading of the leachate is obtained using the following expression (Bear 1979; pp. 181-183):

$$L = \frac{3}{A} \left[\left(\frac{2}{3} Ah_0 + B \right)^{\frac{1}{2}} - B^{\frac{1}{2}} \right] \quad (3)$$

where the constants A and B are defined as:

$$A = \frac{1}{K\sigma'}; \quad B = \frac{B' - N\sigma'}{K\sigma'}$$

and where:

K = hydraulic conductivity of the weathered Mancos Shale [L/T].

$$\sigma' = \frac{B'}{K}$$

B' = thickness of the unweathered Mancos Shale (approximately 2,400 ft from top of unweathered Mancos Shale to uppermost water).

K' = hydraulic conductivity of unweathered Mancos Shale (geometric mean value; 3.5×10^{-8} cm/s).

h_0 = hydraulic head at perimeter of disposal cell (L).

N = recharge rate (L/T).

The calculations are performed using the both the upper-bounding and lower-bounding geometric mean hydraulic conductivities. As referenced in the assumptions, these hydraulic conductivities were obtained from field tests in the weathered Mancos Shale. The calculations are presented in Appendixes A2 through A4 of this section. Table 1 contains a summary of the results of these calculations. Figures 1 and 2 present the estimated limits of the conservatively estimated leachate plume as it spreads laterally.

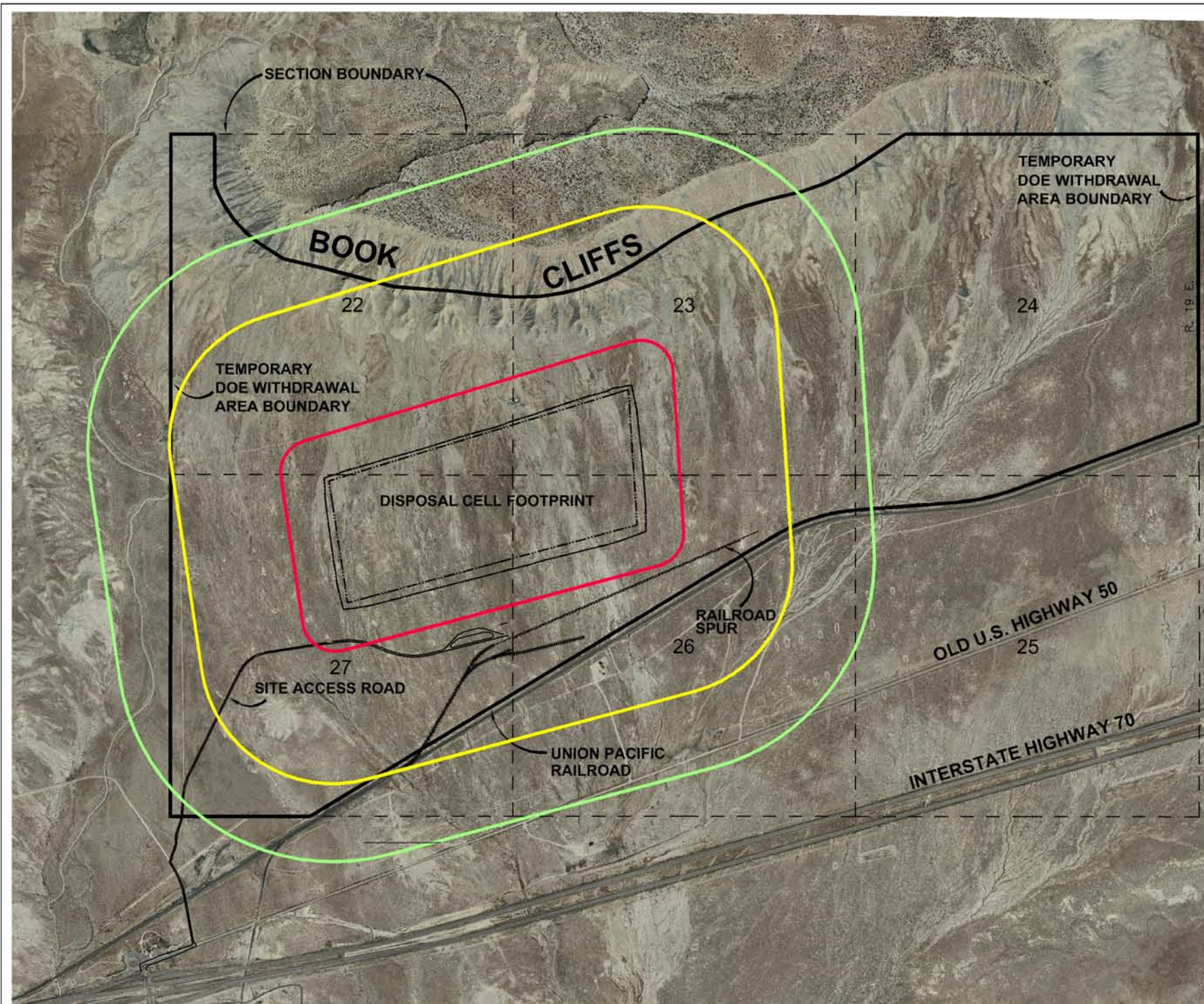

Time	hmax (ft.)	L (ft.) NS Edge	L (ft.) EW Edge	L (ft.) Corner
10 yrs	3.69	694	718	501
200yrs	11.6	2717	2364	2042
1000yrs	16.2	3932	3635	3338

hmax = MAXIMUM HEIGHT OF SATURATED ZONE UNWEATHERED MANCOS SHALE @ CENTER OF DISPOSAL CELL

L = MAXIMUM LENGTH OF LATERAL SPREADING OF LEACHATE FROM EDGE OF DISPOSAL CELL

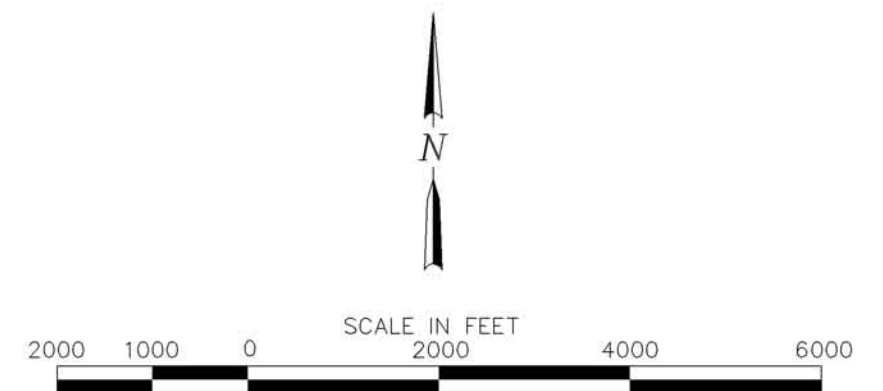

U.S. DEPARTMENT OF ENERGY GRAND JUNCTION, COLORADO	Work Performed by S.M. Stoller Corporation Under DOE Contract No. DE-AC01-02GJ79491
Figure 1	Approximate Limits of Lateral Spreading of Leachate Crescent Junction
DATE PREPARED: JUNE 20, 2007	FILENAME: X0220500

N:\MOA\999\0020\07\009\X02205\X0220500.DWG 06/20/07 12:41pm whitneyj

Figure 1. Approximate Limits of Lateral Spreading of Leachate, Crescent Junction

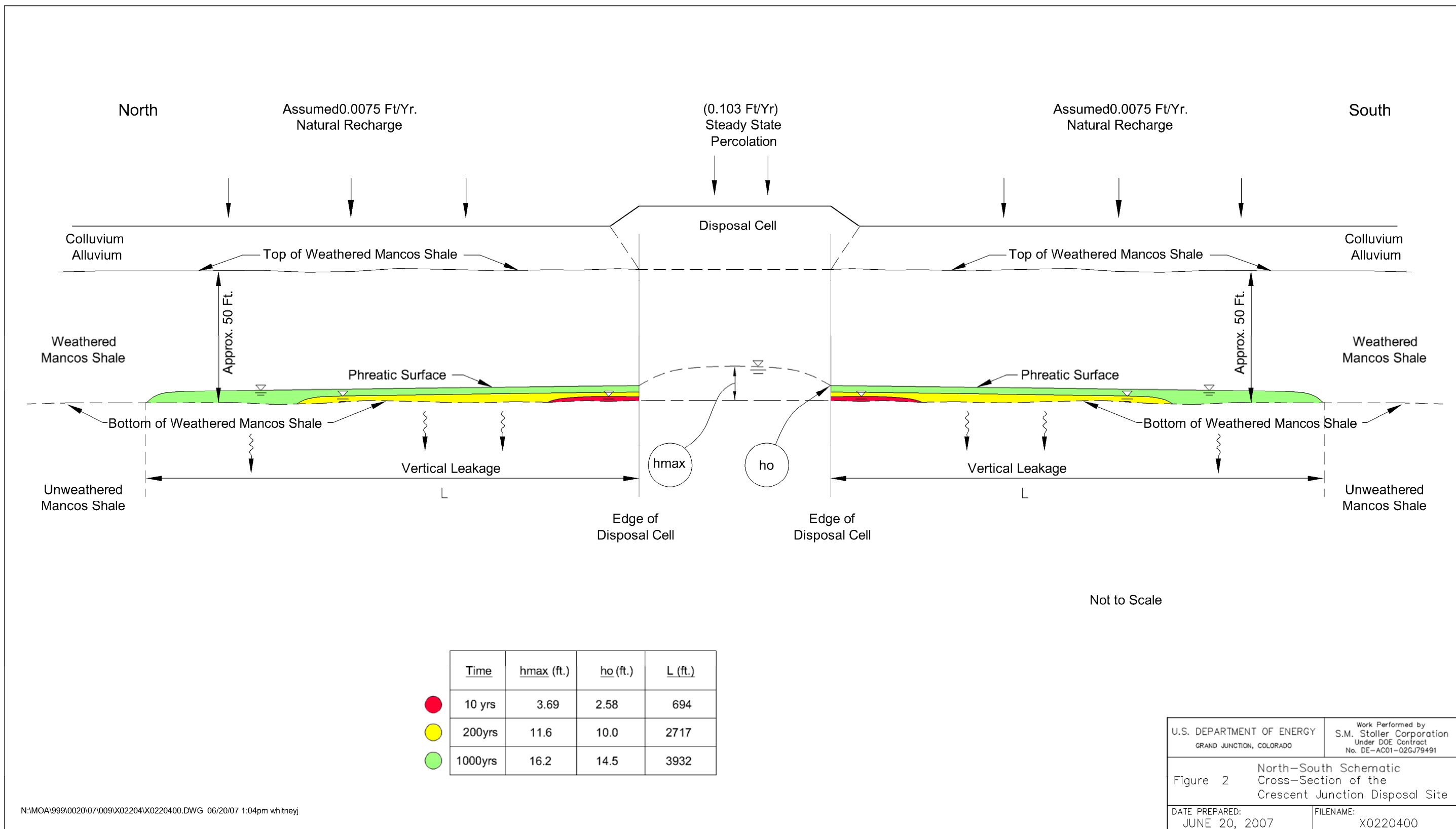

Figure 2. North-South Schematic Cross-Section of the Crescent Junction Disposal Site

Table 1. Summary of Conservatively Estimated Leachate-Mound Dimensions for 10, 200, and 1,000 Years After Onset of Steady Drainage through the Crescent Junction Disposal Cell Cover

Hydrologic Unit	Prediction Interval (yrs)	Hydraulic Conductivity (ft/yr)	h_{max}	Midpoint: (South and North Edge)		Midpoint: (East and West Edge)		Corner	
				h_0 (ft)	L (ft)	h_0 (ft)	L (ft)	h_0 (ft)	L (ft)
Weathered Mancos Shale	10	124	3.71	2.62	173	2.6	166	1.8	113
		2059	3.69	2.58	694	2.6	718	1.8	501
	200	124	16.4	11.7	774	11.6	762	8.3	543
		2,059	11.6	10.0	2,717	8.69	2,364	7.5	2,042
	1,000	124	32.8	25.7	1,693	23.3	1,535	18.2	1,198
		2,059	16.2	14.5	3,932	13.4	3,635	12.3	3,338

h_{max} and h_0 values were obtained using the solutions of Hantush (1967).

L = lateral length-of-spreading values were obtained using the solution of Bear (1979).

Discussion of Conservative Solution:

Down slope of the Crescent Junction Disposal Cell, Kendall Wash incises through Quaternary alluvial and colluvial mud deposits and exposes the contact with the top of the underlying weathered Mancos Shale. Drill-hole logs and borehole geophysical logs have shown that higher permeability zones in the Mancos Shale extend approximately 50 ft into the bedrock. Because gravity drainage will cause leachate to perch along the transition between the weathered and unweathered zones in the Mancos Shale, the conservative case predicts that lateral spreading will occur along this transition zone. Because the transition between weathered and unweathered bedrock is approximately 50 ft below the top of the Mancos Shale, leachate migrating through the weathered bedrock is projected to underflow all ephemeral surface water systems along its path. There is practically no risk of the plume reaching the surface. The leachate is projected to spread laterally until it is entirely consumed by vertical infiltration into the unweathered Mancos Shale.

Two conservative solutions are presented for each time horizon. Each solution corresponds to the upper and lower limits of the hydraulic conductivity in the weathered Mancos Shale. Comparison of the two solutions shows that the smaller hydraulic conductivity produces thicker mounding and shorter distances of lateral spreading. The larger hydraulic conductivity produces less vertical mounding and longer lateral spreading. When using the upper-bounding estimate of hydraulic conductivity of 2059 ft/yr (2.0×10^{-3} cm/s) in the conservative calculation, the maximum thickness of the leachate mound attained at the center of the disposal cell after 1000 years is 16.2 ft, which is small relative to the 50-ft thickness of the weathered bedrock zone. Lateral spreading of the leachate is projected to extend beyond the withdrawal area of the disposal cell, and beyond the surface drainage features of Kendall Wash; however, because the transported leachate would be located at the base of the weathered Mancos Shale, it is unlikely that the leachate plume would ever surface within Kendall Wash.

Realistic Assumptions

Under steady-state conditions, the vertical percolation rate is realistically assumed to be less than 3.5×10^{-8} cm/s. The thickness of the weathered Mancos Shale is approximately 50 ft. The leachate, if any, will migrate to the base the weathered Mancos Shale, continue migrating into the unweathered Mancos Shale, whose geometric mean hydraulic conductivity is 3.5×10^{-8} cm/s. With its downward movement unimpeded at the base of the weathered Mancos Shale, the leachate will migrate vertically beneath the disposal cell.

- If natural recharge at the Crescent Junction Disposal Site were greater than the geometric mean hydraulic conductivity of the unweathered Mancos Shale, there would be a perched water table in the Mancos Shale above the top of the unweathered zone.

- Because there is no perched ground water above the top of the unweathered zone of the Mancos Shale, the steady-state natural recharge must be less than 3.5×10^{-8} cm/s, which is the calculated geometric mean of the packer test data for the unweathered Mancos Shale (RAP Attachment 3, Appendix C, Table 1).
- The natural recharge conditions assumed for the Crescent Junction Site are corroborated by published recharge values, which range from 0.01 to 0.1 mm/yr (3.17×10^{-11} to 3.17×10^{-10} cm/s) for arid and semi arid regions (Walvoord and Scanlon 2004).
- If active recharge at the Crescent Junction Site were occurring, the uppermost ground water at the site would be young, relatively fresh ground water.
- RAP Attachment 3, Appendix F, shows that the uppermost ground water at the Crescent Junction Site is greater than 40,000 years in age and is highly saline; therefore, natural recharge at the Crescent Junction Site is practically zero.
- Measured saturated hydraulic conductivity of the weathered Mancos Shale radon barrier material, compacted to 92 percent of ASTM D-1557 ranges from 5.9×10^{-9} cm/s to 1.4×10^{-12} cm/s (RAP Attachment 5, Appendix K).
- The laboratory tests are an indication of the reductions in permeability that are possible when placing compacted fill; however, they are not being used as an indication of the field-scale reductions that are possible. As stated in NRC (1993), the laboratory measured values of permeability may underestimate the field-scale permeabilities by one order of magnitude or more. Nevertheless, compaction will minimize the void ratio of the engineered materials (Lambe and Whitman 1969) and the hydraulic conductivity of the material that comprises the radon barrier.
- Precipitation events at the Crescent Junction Site are infrequent.
- Fine grained desert soils at the Crescent Junction Site cause meteoric water to run off, primarily as sheet flow, and not to infiltrate. Construction of the disposal cell will cause run-on drainage to be shed laterally in perimeter channels, thereby lessening the volume of sheet flow available for infiltration. Maintaining a 2-percent grade on the top of the disposal cell will cause runoff to be shed from the top of the disposal cell, again lessening the volume of water available for infiltration.
- The steady-state vertical percolation rate through the cover of the disposal cell could be equal to or less than 7.3×10^{-9} cm/s. This rate vertical percolation is a factor of 100 less than the average annual precipitation.
- Steady-state percolation rate through the cover of the disposal cell is insufficient to form a water table above the unweathered bedrock; therefore, there will be no mounding and no lateral spreading.
- Because there is no risk of mounding or lateral spreading above the unweathered bedrock, there is no need for a calculation.

Calculation:

Not Applicable

Discussion of Realistic Assumptions:

By invoking realistic assumptions, there would be no mounding and no lateral spreading of leachate during long-term steady-state conditions. Natural recharge conditions at the site, which are also at steady state, are incapable of forming a perched water table above the unweathered bedrock. If the steady-state recharge rate were larger than it is presently, and were to exceed the geometric mean hydraulic conductivity of the unweathered bedrock, then a shallow ground water table could become perched in the weathered Mancos Shale. Drilling at the disposal site has demonstrated that there is no ground water in the weathered Mancos Shale. The ground water that was encountered at the disposal site was (1) in the unweathered Mancos Shale; (2) a minimum of 130 ft beneath the land surface; (3) very saline, indicating that it is isolated from sources of meteoric recharge; and (4) found to be in excess of 40,000 years in age, indicating that it entered the bedrock during wetter paleoclimatic conditions, possibly during Late Pleistocene time.

Average annual precipitation at the Crescent Junction Disposal Site is 9.1 inches per year (7.3×10^{-7} cm/s), most of which runs off from the land surface. Practically the entire remainder of the meteoric water is stored near the surface and evaporates shortly thereafter. Based on this information, precipitation events at the Crescent Junction Site are decidedly infrequent. Sporadic precipitation events are the primary reason that the disposal cell would seldom be exposed to wetting rains.

The Crescent Junction disposal cell will be constructed using fine-grained silts, clays, and weathered Mancos Shale to shed surface water and prevent long-term steady-state percolation. Engineered compaction of the silt, clay, and weathered Mancos Shale materials will be used to lower the hydraulic conductivity of the engineered cover. Laboratory tests of weathered Mancos Shale radon barrier material, compacted to 92 percent of ASTM D-1557, have shown that the hydraulic conductivity ranges from 5.9×10^{-9} cm/s to 1.4×10^{-12} cm/s (RAP Attachment 5, Appendix K). These test results demonstrate that the compacted weathered Mancos Shale and its residual material will be an effective barrier to steady-state infiltration.

Conclusions and Recommendations:

The conservative assumptions in this calculation are used to show how steady-state leachate could accumulate as a mound above the unweathered bedrock and migrate laterally away from the disposal cell. Figure 1 presents the area where the lateral spreading is conservatively estimated to occur. As conceptualized in this conservative calculation, the leachate becomes perched above the unweathered Mancos Shale and spreads laterally away from the disposal cell. The length of lateral spreading is equal in all directions because homogeneous and isotropic properties are assumed to exist in the weathered Mancos Shale, through which the lateral spreading occurs. Mounding of leachate beneath the footprint of the disposal cell, and lateral spreading of leachate beyond the disposal cell, are entirely contained within the 50-ft thick zone of weathered Mancos Shale.

Estimates of mounding at the center of the disposal cell, after 1,000 years of steady-state seepage, could range from approximately 16 to 33 ft, depending on the hydraulic conductivity of the weathered Mancos Shale. Mounding at the midpoint of the southern edge of the disposal cell, after 1,000 years of steady-state seepage, could range from 14 to 26 ft, depending on the hydraulic conductivity of the weathered Mancos Shale. Lateral spreading beyond the center of the southern edge of the disposal cell, after 1,000 years of steady-state seepage, could range from 1,700 to 3,900 linear ft, depending on the hydraulic conductivity of the weathered Mancos Shale. Vertical mounding of leachate and lateral spreading would occur entirely within the 50-ft-thick weathered zone of Mancos Shale, and so-called "bathtubbing" would be prevented. In addition, the risk of the leachate plume discharging to adjacent surface drainage features is unlikely.

The technical approach to this calculation is simplified yet conservative, because it does not consider several factors that could potentially affect the actual mounding and distance of lateral spreading of leachate. The factors that could limit the mounding and lateral spreading of leachate are listed below:

- Precipitation events at the Crescent Junction Site are few and far between.
- Annual precipitation at the Crescent Junction Site is 9.1 inches per year (7.3×10^{-7} cm/s).
- Most of the precipitation runs off the surface in the form of sheet flow. The small portion of the precipitation that is stored in the near surface evaporates shortly thereafter.
- Natural infiltration of meteoric water at the Crescent Junction Site is probably less than the geometric mean hydraulic conductivity of the unweathered Mancos Shale (3.5×10^{-8} cm/s).
- Steady state recharge at the site is presently insufficient to form perched ground water above the unweathered Mancos Shale.
- The design and construction of the disposal cell will be biased to forming runoff, rather than infiltration, during the infrequent precipitation events that will occur during its performance life.
- Construction of the Crescent Junction Disposal Site will reduce the steady-state recharge to less than what it is under natural conditions.
- (Walvoord and Scanlon 2004) estimate actual recharge in the desert southwestern United States to be approximately 0.01 to 0.1 mm/yr (3.17×10^{-11} to 3.17×10^{-10} cm/s).

- Assuming 1×10^{-7} cm/s to be the long-term seepage rate through the cover of the disposal cell is excessively conservative.
- After steady-state conditions are reestablished, moisture movement through the disposal cell will occur as unsaturated flow.
- Actual steady-state percolation through the disposal cell will equal, or be less than, the present steady-state percolation.
- Steady state percolation will continue to be insufficient to form perched ground water above the unweathered Mancos Shale ($<3.5 \times 10^{-8}$ cm/s).
- The contact between the weathered and unweathered Mancos Shale probably gains in elevation toward the north; consequently, the spreading of leachate, if it were to form, would be impeded as it spreads northward.
- Regardless of the direction of lateral spreading, if it were to form, the gradual consumption of leachate by vertical seepage into the underlying unweathered Mancos Shale could occur preferentially along bedding planes, which dip to the north.

These factors suggest that the realistic assumptions are more likely to influence the steady-state movement of leachate through the disposal cell. Under the influence of the realistic assumptions, and careful adherence to the quality assurance requirements mentioned here and elsewhere, steady-state leachate will percolate vertically into the Mancos Shale, without spreading laterally.

The following recommendations are proposed to assure that the disposal cell will perform as intended:

- Engineered fill should be placed to a relative compaction of 90 percent of Modified Proctor at optimum moisture ± 2 percent, and in lifts spread no thicker than 8 inches.
- Field engineers representing the DOE will be responsible for quality assurance oversight of all aspects of construction and shall have reporting responsibilities and the authority to require rework of areas where engineered fill is being placed outside the acceptable tolerances.
- Quality control will be exercised using nuclear density testing equipment, subject to calibration and third party verification.
- Up to three piezometers (standpipes) are recommended to monitor the accumulation of leachate within the footprint of the disposal cell, during the transient drainage period, to verify that bathtubbing dissipates as steady-state conditions are achieved. In addition, the piezometers may be used to monitor subsurface hydrologic conditions after steady-state drainage is achieved.

Computer Source:

Not applicable.

Appendix A

Attachment A1

Stoller

Calculation of height of mound
@ center of disposal cell (0,0)

JOB NO.: NA

DATE: 5-31-07

JOB NAME: MOAB-RAF

PREPARED: me

REVIEWED:

SHEET NO.: A1-1 OF 5

Summary Page:

CALCULATION OF h_{max} , which occurs @ (0,0)

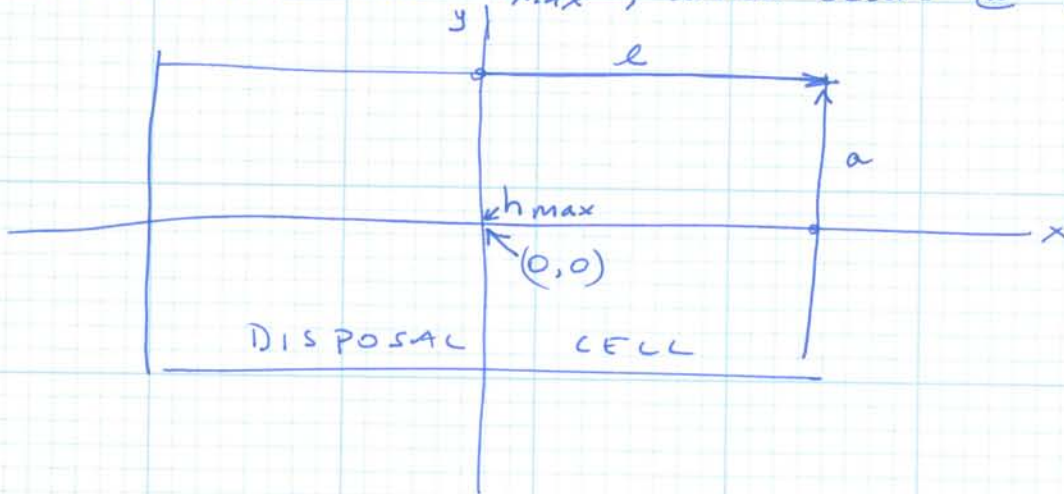

$$K = 124 \text{ ft/yr} @ 10 \text{ yrs} ; h = 3.71 \text{ ft}$$

$$K = 2059 \text{ ft/yr} @ 10 \text{ yrs} ; h = 3.69 \text{ ft}$$

$$K = 124 \text{ ft/yr} @ 200 \text{ yrs} ; h = 16.4 \text{ ft}$$

$$K = 2059 \text{ ft/yr} @ 200 \text{ yrs} ; h = 11.6 \text{ ft}$$

$$K = 124 \text{ ft/yr} @ 1000 \text{ yrs} ; h = 32.8 \text{ ft}$$

$$K = 2059 \text{ ft/yr} @ 1000 \text{ yrs} ; h = 16.2 \text{ ft}$$

Stoller

Calculate flow parameters in Hantush 1967 solution.

JOB NO.: N/A DATE:

JOB NAME: MOAB RAP

PREPARED: me REVIEWED:

SHEET NO.: A1-2 OF 5

For $K = 124 \text{ ft/yr}$ ($1.2 \times 10^{-4} \text{ cm/a}$) → geometric mean AEP Data

Parameter ν : $\nu = \frac{K \bar{b}}{E}$

$$\therefore \nu = \frac{(124 \text{ ft/yr}) \cdot (1 \text{ ft})}{0.15}$$

$$\nu = 827 \text{ ft}^2/\text{yr}$$

... And $\sqrt{4\nu t} = \sqrt{4(827 \text{ ft}^2/\text{yr}) \cdot t(\text{yrs})}$

- @ 10 yrs = 182 ft
- @ 200 yrs = 813 ft
- @ 1000 yrs = 1819 ft

For $K = 2059 \text{ ft/yr}$ ($1.99 \times 10^{-3} \text{ cm/a}$)

→ geometric mean of packer test data

$$\therefore \nu = \frac{(2059 \text{ ft/yr}) \cdot (1 \text{ ft})}{0.15}$$

$$\nu = 13,727 \text{ ft}^2/\text{yr}$$

... And $\sqrt{4\nu t} = \sqrt{4(13,727 \text{ ft}^2/\text{yr}) \cdot t(\text{yrs})}$

where $K =$ hydraulic conductivity $[L/T]$

$\bar{b} =$ constant of linearisation $[L]$

$\bar{b} \approx 1 \text{ ft}$ — assumed value

$E =$ specific yield (dim)

$E \approx 0.15$ (dim) assumed value

For conservative assumptions:

$W =$ percolation rate ($1 \times 10^{-7} \text{ cm/a}$)

$$W = 0.103 \text{ ft/yr}$$

→

- @ 10 yrs = 741 ft
- @ 200 yrs = 3314 ft
- @ 1000 yrs = 7410 ft

Stoller

Calculate height of mound @
center of disposal cell (0,0)
@ 10 yrs (Conservative Assumptions)

JOB NO: N/A

DATE: 5-31-07

JOB NAME: MOAB-RAP

PREPARED: mm

REVIEWED:

SHEET NO: A1-3

OF 5

- Calculate h & h_{max} for Quadrant 1, obtain remaining unknowns by symmetry.

$$h_{max}^{(0,0)} = \frac{2w}{K} \sqrt{Kt} S^* \left(\frac{l}{\sqrt{4Kt}}, \frac{a}{\sqrt{4Kt}} \right)$$

where $\sqrt{4Kt} = 182$ @ 10 yrs
(see sheet A1-1)

- For $K = 124$ ft/yr @ 10 yrs

$$h^2 = \frac{2(0.103 \text{ ft/yr})}{(124 \text{ ft/yr})} (827 \text{ ft}^2/\text{yr}) (10 \text{ yr}) S^* \left(\frac{2500 \text{ ft}}{182 \text{ ft}}, \frac{1100 \text{ ft}}{182 \text{ ft}} \right)$$

$$h^2 = 13.74 \text{ ft}^2 S^*(13.7, 6.04)$$

from Hantush 1967; p. 233 ... if $\alpha \geq 3$ and $\beta \geq 3$, $S^*(\alpha, \beta) \cong 1$

$$\therefore h^2 = 13.74 \text{ ft}^2$$

$$h_{max} = 3.71 \text{ ft} @ 10 \text{ yrs for } K = 124 \text{ ft/yr}$$

- For $K = 2059$ ft/yr @ 10 yrs ... $\sqrt{4Kt} = 241$ ft @ 10 yrs (see sheet A1-1)

$$h^2 = \frac{2(0.103 \text{ ft/yr})}{2059 \text{ ft/yr}} (13,727 \text{ ft}^2/\text{yr}) (10 \text{ yr}) S^* \left(\frac{2500 \text{ ft}}{241 \text{ ft}}, \frac{1100 \text{ ft}}{241 \text{ ft}} \right)$$

$$h^2 = 13.73 \text{ ft}^2 S^*(3.37, 1.48) \quad \text{per Hantush 1967,}$$
$$h^2 = 13.73 \text{ ft}^2 (0.991) \quad S^*(\alpha, \beta) \cong 1 - 4i^2 \text{erfc}(\beta) \text{ if } \alpha \geq 3$$

$$h^2 = 13.6 \text{ ft}^2$$

$$h = 3.69 \text{ ft}$$

per Carslaw & Jaeger App II, TABLE I
for $\beta = 1.48$, $1 - 4i^2 \text{erfc}(\beta) =$
 $1 - 0.009 = 0.991$

Stoller

Calculate height of mound @
center of disposal cell (0,0)
@ 200 yrs (Conservative Assumptions)

JOB NO.: N/A

DATE: 5-31-07

JOB NAME: MOAB-RAP

PREPARED: me

REVIEWED:

SHEET NO.: A1-4 OF 5

- Calculate h & h_{max} for Quadrant I, obtain remaining unknowns by symmetry.

$$h_{max}^2 = \frac{2w}{K} \sqrt{4Nt} S^* \left(\frac{l}{\sqrt{4Nt}}, \frac{a}{\sqrt{4Nt}} \right)$$

where $\sqrt{4Nt} = 813$ @ 200 yrs
(see sheet A1-1)

- For $K = 124$ ft/yr @ 200 yrs

$$h^2 = \frac{2(0.103 \text{ ft/yr})}{(124 \text{ ft/yr})} (827 \text{ ft}^2/\text{yr}) (200 \text{ yr}) S^* \left(\frac{2500 \text{ ft}}{813 \text{ ft}}, \frac{1100 \text{ ft}}{813 \text{ ft}} \right)$$

$$h^2 = 274.8 \text{ ft}^2 S^* (3.075, 1.35)$$

Per Hantush 1967; $S^*(\alpha, \beta) \approx 1 - 4i^2 \text{erfc}(\beta)$
if $\alpha \geq 3$

$$h^2 = 274.8 \text{ ft}^2 (0.985)$$

Per Carslaw & Jaeger, Appn II, Table 1
for $\beta = 1.35$, $1 - 4i^2 \text{erfc}(\beta) = 1 - 0.015$
 $= 0.985$

$$\therefore h^2 = 270 \text{ ft}^2$$

$$h_{max} = 16.4 \text{ ft @ 200 yrs for } K = 124 \text{ ft/yr}$$

- For $K = 2059$ ft/yr @ 200 yrs ... $\sqrt{4Nt} = 3314$ ft @ 200 yrs (see sheet A1-1)

$$h^2 = \frac{2(0.103 \text{ ft/yr})}{2059 \text{ ft/yr}} (13,727 \text{ ft}^2/\text{yr}) (200 \text{ yr}) S^* \left(\frac{2500 \text{ ft}}{3314 \text{ ft}}, \frac{1100 \text{ ft}}{3314 \text{ ft}} \right)$$

$$h^2 = 274.7 \text{ ft}^2 S^* (0.754, 0.332)$$

per Hantush 1967, Table (p. 230)

$$h^2 = 274.7 \text{ ft}^2 (0.49)$$

$$h^2 = 134.6 \text{ ft}^2$$

$$h = 11.6 \text{ ft}$$

Stoller

Calculate height of mound @
center of disposal cell (0,0)
@ 1000 yrs (Conservative Assumptions)

JOB NO.: N/A

DATE: 5-31-07

JOB NAME: MOAB-RAP

PREPARED: me

REVIEWED:

SHEET NO.: A1-5 OF 5

- Calculate h & h_{max} for Quadrant 1, obtain remaining unknowns by symmetry.

$$h_{max}^2 = \frac{2w}{K} \sqrt{4Nt} S^* \left(\frac{l}{\sqrt{4Nt}}, \frac{a}{\sqrt{4Nt}} \right)$$

where $\sqrt{4Nt} = 1819 \text{ ft}$
(see sheet A1-1)

- For $K = 124 \text{ ft/yr}$ @ 1000 yrs

$$h^2 = \frac{2(0.103 \text{ ft/yr})}{(124 \text{ ft/yr})} (827 \text{ ft}^2/\text{yr})(1000 \text{ yr}) S^* \left(\frac{2500 \text{ ft}}{1819 \text{ ft}}, \frac{1100 \text{ ft}}{1819 \text{ ft}} \right)$$

$$h^2 = 1374 \text{ ft}^2 S^*(1.37, 0.605)$$

from Hantush 1967; Table (p. 230)

$$\therefore h^2 = 1075 \text{ ft}^2 \quad 0.782$$

$$h_{max} = 32.8 \text{ ft @ 1000 yrs for } K = 124 \text{ ft/yr}$$

- For $K = 2059 \text{ ft/yr}$ @ 1000 yrs ... $\sqrt{4Nt} = 7410 \text{ ft @ 1000 yrs}$ (see sheet A1-1)

$$h^2 = \frac{2(0.103 \text{ ft/yr})}{2059 \text{ ft/yr}} (13,727 \text{ ft}^2/\text{yr})(1000 \text{ yr}) S^* \left(\frac{2500 \text{ ft}}{7410 \text{ ft}}, \frac{1100 \text{ ft}}{7410 \text{ ft}} \right)$$

$$h^2 = 1373 \text{ ft}^2 S^*(0.337, 0.148) \text{ per Hantush 1967, Table (p. 230)}$$

$$h^2 = 1373 \text{ ft}^2 (0.192)$$

$$h^2 = 263.6 \text{ ft}^2$$

$$h = 16.2 \text{ ft}$$

Attachment A2

Stoller

Calculate height of mound @
south & north midpoint of cell

JOB NO.: N/A DATE: 5-31-07

JOB NAME: MOAB RAP

PREPARED: mm REVIEWED: _____

SHEET NO.: A2-1 OF 13

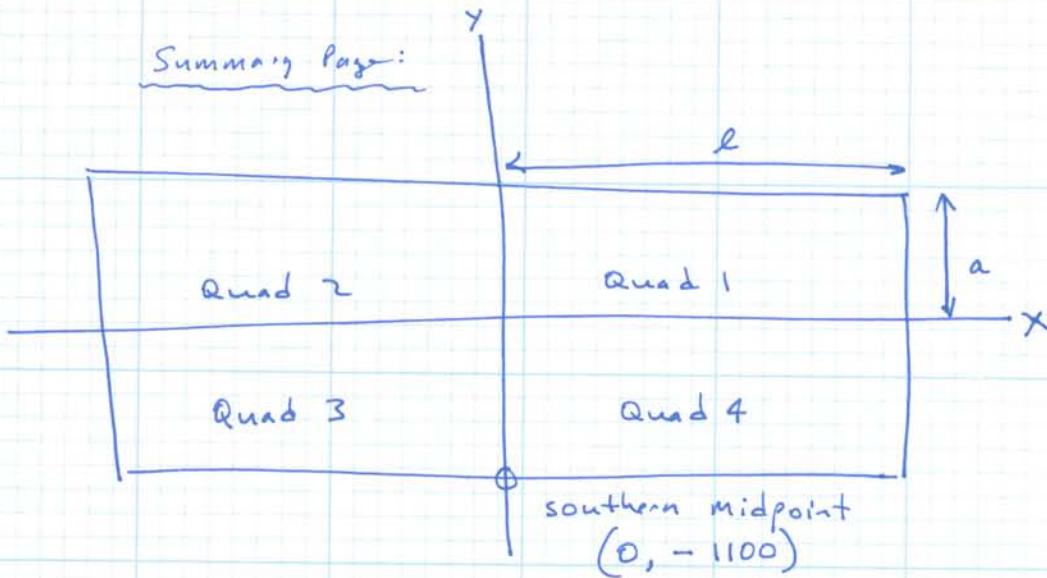

- o Calculate heads for southern midpoint
- o obtain heads for northern midpoint by symmetry.

$$K = 124 \text{ ft/yr @ 10 yrs ; } h = 2.62 \text{ ft ; } L = 173 \text{ ft}$$

$$K = 2059 \text{ ft/yr @ 10 yrs ; } h = 2.58 \text{ ft ; } L = 694 \text{ ft}$$

$$K = 124 \text{ ft/yr @ 200 yrs ; } h = 11.7 \text{ ft ; } L = 774 \text{ ft}$$

$$K = 2059 \text{ ft/yr @ 200 yrs ; } h = 10.0 \text{ ft ; } L = 2717 \text{ ft}$$

$$K = 124 \text{ ft/yr @ 1000 yrs ; } h = 25.7 \text{ ft ; } L = 1693 \text{ ft}$$

$$K = 2059 \text{ ft/yr @ 1000 yrs ; } h = 14.5 \text{ ft ; } L = 3932 \text{ ft}$$

Stoller

Mounding @ southern midpoint of cell
@ 10 yrs for $K = 124 \text{ ft/yr}$

JOB NO: N/A

DATE: 5-31-07

JOB NAME: MoAB RAP

PREPARED: mm

REVIEWED:

SHEET NO: A2-2 OF 13

$$K = 124 \text{ ft/yr}$$

Compute $h_{(x,y)}$ @ 10 yrs:

$$h^2 = \frac{\omega}{2K} vt \cdot \left\{ S^* \left(\frac{l+x}{\sqrt{4vt}}, \frac{a+y}{\sqrt{4vt}} \right) + S^* \left(\frac{l+x}{\sqrt{4vt}}, \frac{a-y}{\sqrt{4vt}} \right) + S^* \left(\frac{l-x}{\sqrt{4vt}}, \frac{a+y}{\sqrt{4vt}} \right) \right.$$

Coord location $(x,y) =$
 $(0, -1100)$

$$+ S^* \left(\frac{l-x}{\sqrt{4vt}}, \frac{a-y}{\sqrt{4vt}} \right) \left. \right\}$$

Recall from Sheet A1-2
@ 10 yrs, $\sqrt{4vt} = 182 \text{ ft}$

$$\textcircled{A} \quad S^* \left(\frac{2500+x}{\sqrt{4vt}}, \frac{1100+y}{\sqrt{4vt}} \right) = S^* \left(\frac{2500 \text{ ft}}{182 \text{ ft}}, \frac{0 \text{ ft}}{182 \text{ ft}} \right) = S^*(13.7, 0) = 0 \text{ (per Hantush)}$$

$$\textcircled{B} \quad S^* \left(\frac{2500+x}{\sqrt{4vt}}, \frac{1100-y}{\sqrt{4vt}} \right) = S^* \left(\frac{2500 \text{ ft}}{182 \text{ ft}}, \frac{2200 \text{ ft}}{182 \text{ ft}} \right) = S^*(13.7, 12.1) = 1 \text{ (per Hantush)}$$

$$\textcircled{C} \quad S^* \left(\frac{2500-x}{\sqrt{4vt}}, \frac{1100+y}{\sqrt{4vt}} \right) = S^* \left(\frac{2500 \text{ ft}}{182 \text{ ft}}, \frac{0 \text{ ft}}{182 \text{ ft}} \right) = S^*(13.7, 0) = 0 \text{ (per Hantush)}$$

$$\textcircled{D} \quad S^* \left(\frac{2500-x}{\sqrt{4vt}}, \frac{1100-y}{\sqrt{4vt}} \right) = S^* \left(\frac{2500 \text{ ft}}{182 \text{ ft}}, \frac{2200 \text{ ft}}{182 \text{ ft}} \right) = S^*(13.7, 12.1) = 1 \text{ (per Hantush)}$$

$$h^2 = \frac{0.103 \text{ ft/yr}}{2 (124 \text{ ft/yr})} (827 \text{ ft}^2/\text{yr}) (10 \text{ yr}) \left(\begin{matrix} \textcircled{A} & \textcircled{B} & \textcircled{C} & \textcircled{D} \\ 0 & + & 1 & + & 0 & + & 1 \end{matrix} \right)$$

$$h^2 = 6.87 \text{ ft}^2$$

$$h = 2.62 \text{ ft}$$

Stoller

Mounding @ southern midpoint of cell
@ 10 yrs for $K = 2059 \text{ ft/yr}$

JOB NO: N/A

DATE: 5-31-07

JOB NAME: MOAB RAP

PREPARED: MK

REVIEWED:

SHEET NO: A2-3

OF

13

$$K = 2059 \text{ ft/yr}$$

compute $h(x,y)$ @ 10 yrs:

$$h^2 = \frac{\omega}{2K} vt \cdot \left\{ S^* \left(\frac{l+x}{\sqrt{4vt}}, \frac{a+y}{\sqrt{4vt}} \right) + S^* \left(\frac{l+x}{\sqrt{4vt}}, \frac{a-y}{\sqrt{4vt}} \right) + S^* \left(\frac{l-x}{\sqrt{4vt}}, \frac{a+y}{\sqrt{4vt}} \right) + S^* \left(\frac{l-x}{\sqrt{4vt}}, \frac{a-y}{\sqrt{4vt}} \right) \right\}$$

Coord location $(x,y) = (0, -1100)$

Recall from sheet A1-2
 $\sqrt{4vt} = 741 \text{ ft}$ (if $K = 2059 \text{ ft/yr}$)

$$\textcircled{A} S^* \left(\frac{2500+x}{\sqrt{4vt}}, \frac{1100+y}{\sqrt{4vt}} \right) = S^* \left(\frac{2500 \text{ ft}}{741 \text{ ft}}, \frac{0 \text{ ft}}{741 \text{ ft}} \right) = S^*(3.37, 0) = 0 \text{ (per Hantush)}$$

$$\textcircled{B} S^* \left(\frac{2500+x}{\sqrt{4vt}}, \frac{1100-y}{\sqrt{4vt}} \right) = S^* \left(\frac{2500 \text{ ft}}{741 \text{ ft}}, \frac{2200 \text{ ft}}{741 \text{ ft}} \right) = S^*(3.37, 2.97) \approx 1 \text{ (per Hantush and Carslaw & Jaeger)}$$

$$\textcircled{C} S^* \left(\frac{2500-x}{\sqrt{4vt}}, \frac{1100+y}{\sqrt{4vt}} \right) = S^* \left(\frac{2500 \text{ ft}}{741 \text{ ft}}, \frac{0 \text{ ft}}{741 \text{ ft}} \right) = S^*(3.37, 0) = 0 \text{ (per Hantush)}$$

$$\textcircled{D} S^* \left(\frac{2500-x}{\sqrt{4vt}}, \frac{1100-y}{\sqrt{4vt}} \right) = S^* \left(\frac{2500 \text{ ft}}{741 \text{ ft}}, \frac{2200 \text{ ft}}{741 \text{ ft}} \right) = S^*(3.37, 2.97) \approx 1 \text{ (per Hantush and Carslaw & Jaeger)}$$

$$h^2 = \frac{0.103 \text{ ft/yr}}{2 (2059 \text{ ft/yr})} \left(13,727 \text{ ft}^2/\text{yr} \right) (10 \text{ yr}) \left(\begin{matrix} \textcircled{A} & \textcircled{B} & \textcircled{C} & \textcircled{D} \\ 0 & + 1 & + 0 & + 1 \end{matrix} \right)$$

$$h^2 = 6.67 \text{ ft}^2$$

$$h = 2.58 \text{ ft}$$

Stoller

Mounding @ southern midpoint of cell @ 200 yrs for $K = 124 \text{ ft/yr}$

JOB NO. N/A

DATE: 5-31-07

JOB NAME: MOAB RAP

PREPARED: *mm*

REVIEWED:

SHEET NO. A-2-4 OF 13

$$K = 124 \text{ ft/yr}$$

Compute $h(x,y)$ @ 200 yrs:

$$h^2 = \frac{w}{2K} vt \cdot \left\{ S^* \left(\frac{l+x}{\sqrt{4vt}}, \frac{a+y}{\sqrt{4vt}} \right) + S^* \left(\frac{l+x}{\sqrt{4vt}}, \frac{a-y}{\sqrt{4vt}} \right) + S^* \left(\frac{l-x}{\sqrt{4vt}}, \frac{a+y}{\sqrt{4vt}} \right) \right.$$

location coordinate
(0, -1100)

$$+ S^* \left(\frac{l-x}{\sqrt{4vt}}, \frac{a-y}{\sqrt{4vt}} \right) \left. \right\}$$

Recall from sheet A1-2,
 $\sqrt{4vt} = 813$

$$\textcircled{A} \quad S^* \left(\frac{2500+x}{\sqrt{4vt}}, \frac{1100+y}{\sqrt{4vt}} \right) = S^* \left(\frac{2500 \text{ ft}}{813 \text{ ft}}, \frac{0 \text{ ft}}{813 \text{ ft}} \right) = S^*(3.075, 0) \approx 0 \text{ (Hantush)}$$

$$\textcircled{B} \quad S^* \left(\frac{2500+x}{\sqrt{4vt}}, \frac{1100-y}{\sqrt{4vt}} \right) = S^* \left(\frac{2500}{813}, \frac{2200}{813} \right) = S^*(3.075, 2.706) \approx 1 \text{ (Hantush)}$$

$$\textcircled{C} \quad S^* \left(\frac{2500-x}{\sqrt{4vt}}, \frac{1100+y}{\sqrt{4vt}} \right) = S^* \left(\frac{2500}{813}, \frac{0}{813} \right) = S^*(3.075, 0) \approx 0 \text{ (Hantush)}$$

$$\textcircled{D} \quad S^* \left(\frac{2500-x}{\sqrt{4vt}}, \frac{1100-y}{\sqrt{4vt}} \right) = S^* \left(\frac{2500}{813}, \frac{2200}{813} \right) = S^*(3.075, 2.706) \approx 1 \text{ (Hantush)}$$

$$h^2 = \frac{0.103 \text{ ft/yr}}{2 (124 \text{ ft/yr})} \left(827 \text{ ft}^2/\text{yr} \right) (200 \text{ yr}) \left(\begin{matrix} \textcircled{A} & \textcircled{B} & \textcircled{C} & \textcircled{D} \\ 0 & + 1 & + 0 & + 1 \end{matrix} \right)$$

$$h^2 = 137 \text{ ft}^2$$

$$h = 11.7 \text{ ft}$$

Stoller

Mounding @ southern midpoint of cell @ 200 yrs for $K = 2059 \text{ ft/yr}$.

JOB NO. N/A

DATE 5-31-07

JOB NAME: MD4B RAP

PREPARED: *mm*

REVIEWED:

SHEET NO. 42-5 OF 13

$$K = 2059 \text{ ft/yr}$$

Compute $h(x,y)$ @ 200 yrs:

$$h^2 = \frac{w}{2K} vt \cdot \left\{ S^* \left(\frac{l+x}{\sqrt{4vt}}, \frac{a+y}{\sqrt{4vt}} \right) + S^* \left(\frac{l+x}{\sqrt{4vt}}, \frac{a-y}{\sqrt{4vt}} \right) + S^* \left(\frac{l-x}{\sqrt{4vt}}, \frac{a+y}{\sqrt{4vt}} \right) \right.$$

Coord. location
(0, -1100)

$$+ S^* \left(\frac{l-x}{\sqrt{4vt}}, \frac{a-y}{\sqrt{4vt}} \right) \left. \right\}$$

Recall from Sheet A1-2

$$\sqrt{4vt} = 3314 \text{ ft}$$

$$\frac{1}{2} v = 13,727 \text{ ft}^2/\text{yr}$$

$$\textcircled{A} S^* \left(\frac{2500+x}{\sqrt{4vt}}, \frac{1100+y}{\sqrt{4vt}} \right) = S^* \left(\frac{2500 \text{ ft}}{3314 \text{ ft}}, \frac{0 \text{ ft}}{3314 \text{ ft}} \right) = S^*(0.754, 0) = 0 \text{ (per Hantush)}$$

$$\textcircled{B} S^* \left(\frac{2500+x}{\sqrt{4vt}}, \frac{1100-y}{\sqrt{4vt}} \right) = S^* \left(\frac{2500 \text{ ft}}{3314 \text{ ft}}, \frac{2200 \text{ ft}}{3314 \text{ ft}} \right) = S^*(0.754, 0.664) \approx 0.73 \text{ (per Hantush)}$$

$$\textcircled{C} S^* \left(\frac{2500-x}{\sqrt{4vt}}, \frac{1100+y}{\sqrt{4vt}} \right) = S^* \left(\frac{2500 \text{ ft}}{3314 \text{ ft}}, \frac{0 \text{ ft}}{3314 \text{ ft}} \right) = S^*(0.754, 0) = 0 \text{ (per Hantush)}$$

$$\textcircled{D} S^* \left(\frac{2500-x}{\sqrt{4vt}}, \frac{1100-y}{\sqrt{4vt}} \right) = S^* \left(\frac{2500 \text{ ft}}{3314 \text{ ft}}, \frac{2200 \text{ ft}}{3314 \text{ ft}} \right) = S^*(0.754, 0.664) \approx 0.73 \text{ (per Hantush)}$$

$$h^2 = \frac{0.103 \text{ ft/yr}}{2 (2059 \text{ ft/yr})} (13,727 \text{ ft}^2/\text{yr}) (200 \text{ yr}) \left(\overset{\textcircled{A}}{0} + \overset{\textcircled{B}}{0.73} + \overset{\textcircled{C}}{0} + \overset{\textcircled{D}}{0.73} \right)$$

$$h^2 = 100.2 \text{ ft}^2$$

$$h = 10.0 \text{ ft}$$

Stoller

Mounding @ southern midpoint of cell
@ 1000 yrs for $K = 124 \text{ ft/yr}$.

JOB NO: N/A DATE: 5-31-07

JOB NAME: MOAB RAP

PREPARED: mm REVIEWED:

SHEET NO: 42-6 OF 13

$$K = 124 \text{ ft/yr}$$

Compute $h(x,y)$ @ 1000 yrs:

$$h^2 = \frac{w}{2K} vt \cdot \left\{ S^* \left(\frac{l+x}{\sqrt{4vt}}, \frac{a+y}{\sqrt{4vt}} \right) + S^* \left(\frac{l+x}{\sqrt{4vt}}, \frac{a-y}{\sqrt{4vt}} \right) + S^* \left(\frac{l-x}{\sqrt{4vt}}, \frac{a+y}{\sqrt{4vt}} \right) \right.$$

Coordinate Location
0, -1100

$$+ S^* \left(\frac{l-x}{\sqrt{4vt}}, \frac{a-y}{\sqrt{4vt}} \right) \left. \right\}$$

Recall from sheet A1-2

$$\sqrt{4vt} = 1819 \text{ ft}$$

$$\& v = 827$$

$$\textcircled{A} \quad S^* \left(\frac{2500+x}{\sqrt{4vt}}, \frac{1100+y}{\sqrt{4vt}} \right) = S^* \left(\frac{2500 \text{ ft}}{1819 \text{ ft}}, \frac{0 \text{ ft}}{1819 \text{ ft}} \right) = S^*(1.37, 0) \approx 0 \text{ (per Hantush)}$$

$$\textcircled{B} \quad S^* \left(\frac{2500+x}{\sqrt{4vt}}, \frac{1100-y}{\sqrt{4vt}} \right) = S^* \left(\frac{2500 \text{ ft}}{1819 \text{ ft}}, \frac{2200 \text{ ft}}{1819 \text{ ft}} \right) = S^*(1.37, 1.21) \approx 0.96 \text{ (per Hantush)}$$

$$\textcircled{C} \quad S^* \left(\frac{2500-x}{\sqrt{4vt}}, \frac{1100+y}{\sqrt{4vt}} \right) = S^* \left(\frac{2500 \text{ ft}}{1819 \text{ ft}}, \frac{0 \text{ ft}}{1819 \text{ ft}} \right) = S^*(1.37, 0) \approx 0 \text{ (Hantush)}$$

$$\textcircled{D} \quad S^* \left(\frac{2500-x}{\sqrt{4vt}}, \frac{1100-y}{\sqrt{4vt}} \right) = S^* \left(\frac{2500 \text{ ft}}{1819 \text{ ft}}, \frac{2200 \text{ ft}}{1819 \text{ ft}} \right) = S^*(1.37, 1.21) \approx 0.96 \text{ (Hantush)}$$

$$h^2 = \frac{0.103 \text{ ft/yr}}{2 (124 \text{ ft/yr})} (827 \text{ ft}^2/\text{yr}) (1000 \text{ yr}) \left(\overset{\textcircled{A}}{0} + \overset{\textcircled{B}}{0.96} + \overset{\textcircled{C}}{0} + \overset{\textcircled{D}}{0.96} \right)$$

$$h^2 = 659 \text{ ft}^2$$

$$h = 25.7 \text{ ft}$$

Stoller

Mounding at southern midpoint of cell
@ 1000 yrs for $K = 2059 \text{ ft/yr}$

JOB NO: N/A

DATE: 5-31-07

JOB NAME: MOARS RAP

PREPARED: mm

REVIEWED:

SHEET NO: A2-7 OF 13

$$K = 2059 \text{ ft/yr}$$

Compute $h(x,y)$ @ 1000 yrs:

$$h^2 = \frac{\omega}{2K} vt \cdot \left\{ S^* \left(\frac{l+x}{\sqrt{4vt}}, \frac{a+y}{\sqrt{4vt}} \right) + S^* \left(\frac{l+x}{\sqrt{4vt}}, \frac{a-y}{\sqrt{4vt}} \right) + S^* \left(\frac{l-x}{\sqrt{4vt}}, \frac{a+y}{\sqrt{4vt}} \right) \right.$$

Coord Loc.
(0, -1100)

$$+ S^* \left(\frac{l-x}{\sqrt{4vt}}, \frac{a-y}{\sqrt{4vt}} \right) \left. \right\}$$

Recall from sheet A1-2
 $\sqrt{4vt} = 7410 \text{ ft}$

$$\& N = 13,727 \text{ ft}^2/\text{yr}$$

$$\textcircled{A} \quad S^* \left(\frac{2500+x}{\sqrt{4vt}}, \frac{1100+y}{\sqrt{4vt}} \right) = S^* \left(\frac{2500 \text{ ft}}{7410 \text{ ft}}, \frac{0 \text{ ft}}{7410 \text{ ft}} \right) = S^*(0.337, 0) \approx 0 \text{ (Hantush)}$$

$$\textcircled{B} \quad S^* \left(\frac{2500+x}{\sqrt{4vt}}, \frac{1100-y}{\sqrt{4vt}} \right) = S^* \left(\frac{2500 \text{ ft}}{7410 \text{ ft}}, \frac{2200 \text{ ft}}{7410 \text{ ft}} \right) = S^*(0.337, 0.297) \approx 0.305 \text{ (Hantush)}$$

$$\textcircled{C} \quad S^* \left(\frac{2500-x}{\sqrt{4vt}}, \frac{1100+y}{\sqrt{4vt}} \right) = S^* \left(\frac{2500 \text{ ft}}{7410 \text{ ft}}, \frac{0 \text{ ft}}{7410 \text{ ft}} \right) = S^*(0.337, 0) \approx 0 \text{ (Hantush)}$$

$$\textcircled{D} \quad S^* \left(\frac{2500-x}{\sqrt{4vt}}, \frac{1100-y}{\sqrt{4vt}} \right) = S^* \left(\frac{2500 \text{ ft}}{7410 \text{ ft}}, \frac{2200 \text{ ft}}{7410 \text{ ft}} \right) = S^*(0.337, 0.297) \approx 0.305 \text{ (Hantush)}$$

$$h^2 = \frac{0.103 \text{ ft/yr}}{2 (2059 \text{ ft/yr})} (13,727 \text{ ft}^2/\text{yr}) (1000 \text{ yrs}) \left(\begin{matrix} \textcircled{A} & \textcircled{B} & \textcircled{C} & \textcircled{D} \\ 0 & + 0.305 & + 0 & + 0.305 \end{matrix} \right)$$

$$h^2 = 209 \text{ ft}^2$$

$$h = 14.5 \text{ ft}$$

Stoller

Length of Spreading of Leachate @ 10yrs
from edge of disposal cell
↑ southern midpoint (0, -1100)

JOB NO.: N/A

DATE: 5-31-07

JOB NAME: Moab RAP

PREPARED: *me*

REVIEWED:

SHEET NO.: A2-8 OF 13

$$L = \frac{3}{A} \left[\left(\frac{2}{3} A h_0 + B \right)^{1/2} - B^{1/2} \right] \quad \text{from Bear, (1979; p. 181-183)} \\ \text{eqn 5-219}$$

$$\text{Let } K = 124 \text{ ft/yr}$$

$$A = \frac{1}{K \sigma'} ; \sigma' = \frac{B'}{K'}$$

$$\therefore \sigma' = \frac{2400 \text{ ft}}{0.036 \text{ ft/yr}} = 6.67 \times 10^4 \text{ yr}$$

where B' = thickness of semipermeous unit (2400 ft)

K' = hydraulic conductivity of semipermeous unit

$$K' = 0.036 \text{ ft/yr}$$

h_0 = head at edge of disposal cell

$$A = \frac{1}{(124 \text{ ft/yr}) (6.67 \times 10^4 \text{ yr})}$$

$$A = 1.21 \times 10^{-7} \text{ ft}^{-1}$$

$$\text{Assume } N = (0.01) * (\text{avg. annual precip.}) = 7.5 \times 10^{-3} \text{ ft/yr} \approx N$$

$$B = \frac{B' - N \sigma'}{K \sigma'} = \frac{2400 \text{ ft} - (7.5 \times 10^{-3} \text{ ft/yr} \cdot 6.67 \times 10^4 \text{ yr})}{(124 \text{ ft/yr}) (6.67 \times 10^4 \text{ yr})}$$

$$B = 2.30 \times 10^{-4} \text{ dim}$$

$$L = \frac{3}{1.21 \times 10^{-7} \text{ ft}^{-1}} \left[\left(\frac{2}{3} (1.21 \times 10^{-7} \text{ ft}^{-1} \cdot 2.62 \text{ ft}) + 2.30 \times 10^{-4} \right)^{1/2} + (2.30 \times 10^{-4})^{1/2} \right]$$

$$L = \frac{3}{1.21 \times 10^{-7} \text{ ft}^{-1}} \left(1.5173 \times 10^{-2} - 1.5166 \times 10^{-2} \right)$$

$$L = 173 \text{ ft}$$

Stoller

Length of Spreading of Leachate @ 200 yrs
from edge of disposal cell
↑ southern midpoint (0, -1100)

JOB NO.: N/A

DATE: 5-31-07

JOB NAME: Moab RAP

PREPARED: mm

REVIEWED:

SHEET NO.: A2-9 OF 13

$$L = \frac{3}{A} \left[\left(\frac{2}{3} A h_0 + B \right)^{1/2} - B^{1/2} \right] \quad \text{from Bear, (1979; p. 181-183)} \\ \text{eqn 5-219)}$$

$$\text{Let } K = 124 \text{ ft/yr}$$

$$A = \frac{1}{K \sigma'} ; \sigma' = \frac{B'}{K'}$$

$$\therefore \sigma' = \frac{2400 \text{ ft}}{0.036 \text{ ft/yr}} = 6.67 \times 10^4 \text{ yr}$$

where B' = thickness of semipermeous unit (2400 ft)

K' = hydraulic conductivity of semipermeous unit

$$K' = 0.036 \text{ ft/yr}$$

h_0 = head at edge of disposal cell

$$A = \frac{1}{(124 \text{ ft/yr})(6.67 \times 10^4 \text{ yr})}$$

$$A = 1.21 \times 10^{-7} \text{ ft}^{-1}$$

$$\text{Assume } N = (0.01) * (\text{avg. annual pcp.}) = 7.5 \times 10^{-3} \text{ ft/yr} \approx N$$

$$B = \frac{B' - N \sigma'}{K \sigma'} = \frac{2400 \text{ ft} - (7.5 \times 10^{-3} \text{ ft/yr} \cdot 6.67 \times 10^4 \text{ yr})}{(124 \text{ ft/yr})(6.67 \times 10^4 \text{ yr})}$$

$$B = 2.30 \times 10^{-4} \text{ dim}$$

$$L = \frac{3}{1.21 \times 10^{-7} \text{ ft}^{-1}} \left[\left(\frac{2}{3} (1.21 \times 10^{-7} \text{ ft}^{-1} \cdot 11.7 \text{ ft}) + 2.30 \times 10^{-4} \right)^{1/2} + (2.30 \times 10^{-4})^{1/2} \right]$$

$$L = \frac{3}{1.21 \times 10^{-7} \text{ ft}^{-1}} \left(1.520 \times 10^{-2} - 1.5166 \times 10^{-2} \right)$$

$$L = 774 \text{ ft}$$

Stoller

Length of Spreading of Leachate @ 1000yrs
from edge of disposal cell
↑
southern midpoint (0, -1100)

JOB NO.: N/A

DATE: 5-31-07

JOB NAME: Moab RAP

PREPARED: me

REVIEWED:

SHEET NO.: A2-10 OF 13

$$L = \frac{3}{A} \left[\left(\frac{2}{3} A h_0 + B \right)^{1/2} - B^{1/2} \right] \quad \text{from Bear, (1979; p. 181-183)} \\ \text{eqn 5-219}$$

$$\text{Let } K = 124 \text{ ft/yr}$$

$$A = \frac{1}{K \sigma'} ; \sigma' = \frac{B'}{K'}$$

$$\therefore \sigma' = \frac{2400 \text{ ft}}{0.036 \text{ ft/yr}} = 6.67 \times 10^4 \text{ yr}$$

where B' = thickness of semipermeous unit (2400 ft)

K' = hydraulic conductivity of semipermeous unit

$$K' = 0.036 \text{ ft/yr}$$

h_0 = head at edge of disposal cell

$$A = \frac{1}{(124 \text{ ft/yr})(6.67 \times 10^4 \text{ yr})}$$

$$A = 1.21 \times 10^{-7} \text{ ft}^{-1}$$

$$\text{Assume } N = (0.01) * (\text{avg. annual pop.}) = 7.5 \times 10^{-3} \text{ ft/yr} \approx N$$

$$B = \frac{B' - N \sigma'}{K \sigma'} = \frac{2400 \text{ ft} - (7.5 \times 10^{-3} \text{ ft/yr} \cdot 6.67 \times 10^4 \text{ yr})}{(124 \text{ ft/yr})(6.67 \times 10^4 \text{ yr})}$$

$$B = 2.30 \times 10^{-4} \text{ dim}$$

$$L = \frac{3}{1.03 \times 10^{-7} \text{ ft}^{-1}} \left[\left(\frac{2}{3} (1.21 \times 10^{-7} \text{ ft}^{-1} \cdot 25.7 \text{ ft}) + 2.30 \times 10^{-4} \right)^{1/2} + (2.30 \times 10^{-4})^{1/2} \right]$$

$$L = \frac{3}{1.21 \times 10^{-7} \text{ ft}^{-1}} \left(1.5234 \times 10^{-2} - 1.5166 \times 10^{-2} \right)$$

$$L = 1693 \text{ ft}$$

Stoller

Length of Spreading of Leachate (@ 10 yrs)
from edge of disposal cell
↑ southern edge (0, 1100)

JOB NO.: N/A

DATE: 5-31-07

JOB NAME: Moab RAP

PREPARED: *mm*

REVIEWED:

SHEET NO.: A2-11 OF 13

$$L = \frac{3}{A} \left[\left(\frac{2}{3} A h_0 + B \right)^{\frac{1}{2}} - B^{\frac{1}{2}} \right] \quad \text{from Bear (1979; p 181-183; Equation 5-219)}$$

Let $K = 2059 \text{ ft/yr}$

$$A = \frac{1}{K \sigma'} ; \sigma' = \frac{B'}{K'}$$

where B' = thickness of semipervious unit (2400 ft)
 K' = hydraulic conductivity of semipervious unit

$$\sigma' = \frac{2400 \text{ ft}}{0.036 \text{ ft/yr}} = 6.67 \times 10^4 \text{ yr}$$

$$K' = 0.036 \text{ ft/yr}$$

h_0 = head at edge of disposal cell

$$A = \frac{1}{(2059 \text{ ft/yr})(6.67 \times 10^4 \text{ yr})} = \boxed{7.28 \times 10^{-9} \text{ ft}^{-1} = A}$$

Assume $N = 0.01 * (\text{avg. annual pcpr}) = \boxed{7.5 \times 10^{-3} \text{ ft/yr} \approx N}$

$$B = \frac{B' - N \sigma'}{K \sigma'} = \frac{2400 \text{ ft} - (7.5 \times 10^{-3} \text{ ft/yr} \cdot 6.67 \times 10^4 \text{ yr})}{(2059 \text{ ft/yr})(6.67 \times 10^4 \text{ yr})}$$

$$\boxed{B = 1.38 \times 10^{-5} \text{ dim}}$$

$$L = \frac{3}{7.28 \times 10^{-9} \text{ ft}^{-1}} \left[\left(\frac{2}{3} \left(7.28 \times 10^{-9} \text{ ft}^{-1} \cdot 2.58 \text{ ft} \right) + 1.38 \times 10^{-5} \right)^{\frac{1}{2}} - \left(1.38 \times 10^{-5} \right)^{\frac{1}{2}} \right]$$

$$L = \frac{3}{7.28 \times 10^{-9} \text{ ft}^{-1}} \left(3.716 \times 10^{-3} - 3.7148 \times 10^{-3} \right)$$

$$L = 694 \text{ ft}$$

Stoller

Length of Spreading of Leachate
from edge of disposal cell

JOB NO.: N/A DATE: 5-31-07

JOB NAME: MOAB RAP

PREPARED: mm REVIEWED:

SHEET NO.: 42-12 OF 13

$$L = \frac{3}{A} \left[\left(\frac{2}{3} A h_0 + B \right)^{\frac{1}{2}} - B^{\frac{1}{2}} \right] \quad \text{from Bear (1979; p 181-183; Equation 5-219)}$$

Let $K = 2059 \text{ ft/yr}$

$$A = \frac{1}{K \sigma'} ; \sigma' = \frac{B'}{K'}$$

where B' = thickness of semipervious unit (2400 ft)
 K' = hydraulic conductivity of semipervious unit

$$\sigma' = \frac{2400 \text{ ft}}{0.036 \text{ ft/yr}} = 6.67 \times 10^4 \text{ yr}$$

$$K' = 0.036 \text{ ft/yr}$$

h_0 = head at edge of disposal cell

$$A = \frac{1}{(2059 \text{ ft/yr})(6.67 \times 10^4 \text{ yr})} = \boxed{7.28 \times 10^{-9} \text{ ft}^{-1} = A}$$

Assume $N = 0.01 * (\text{avg. annual pcpr}) = \boxed{7.5 \times 10^{-3} \text{ ft/yr} \approx N}$

$$B = \frac{B' - N \sigma'}{K \sigma'} = \frac{2400 \text{ ft} - (7.5 \times 10^{-3} \text{ ft/yr} \cdot 6.67 \times 10^4 \text{ yr})}{(2059 \text{ ft/yr})(6.67 \times 10^4 \text{ yr})}$$

$$\boxed{B = 1.38 \times 10^{-5} \text{ dim}}$$

$$L = \frac{3}{7.28 \times 10^{-9} \text{ ft}^{-1}} \left[\left(\frac{2}{3} \left(7.28 \times 10^{-9} \text{ ft}^{-1} \cdot 10.0 \text{ ft} \right) + 1.38 \times 10^{-5} \right)^{\frac{1}{2}} - \left(1.38 \times 10^{-5} \right)^{\frac{1}{2}} \right]$$

$$L = \frac{3}{7.28 \times 10^{-9} \text{ ft}^{-1}} \left(3.7214 \times 10^{-3} - 3.7148 \times 10^{-3} \right)$$

$$L = 2717 \text{ ft}$$

Stoller

Length of Spreading of Leachate
from edge of disposal cell

JOB NO.: N/A

DATE: 5-31-07

JOB NAME: Moab RAP

PREPARED: *mm*

REVIEWED:

SHEET NO.: A2-13 OF 13

$$L = \frac{3}{A} \left[\left(\frac{2}{3} A h_0 + B \right)^{\frac{1}{2}} - B^{\frac{1}{2}} \right] \quad \text{from Bear (1979; p 181-183; Equation 5-219)}$$

$$\text{Let } K = 2059 \text{ ft/yr}$$

$$A = \frac{1}{K \sigma'} ; \sigma' = \frac{B'}{K'}$$

where B' = thickness of semipervious unit (2400 ft)
 K' = hydraulic conductivity of semipervious unit

$$\sigma' = \frac{2400 \text{ ft}}{0.036 \text{ ft/yr}} = 6.67 \times 10^4 \text{ yr}$$

$$K' = 0.036 \text{ ft/yr}$$

h_0 = head at edge of disposal cell

$$A = \frac{1}{(2059 \text{ ft/yr})(6.67 \times 10^4 \text{ yr})} = \boxed{7.28 \times 10^{-9} \text{ ft}^{-1} = A}$$

$$\text{Assume } N = 0.01 * (\text{avg. annual pcp}) = \boxed{7.5 \times 10^{-3} \text{ ft/yr} \approx N}$$

$$B = \frac{B' - N \sigma'}{K \sigma'} = \frac{2400 \text{ ft} - (7.5 \times 10^{-3} \text{ ft/yr} \cdot 6.67 \times 10^4 \text{ yr})}{(2059 \text{ ft/yr})(6.67 \times 10^4 \text{ yr})}$$

$$\boxed{B = 1.38 \times 10^{-5} \text{ dim}}$$

$$L = \frac{3}{7.28 \times 10^{-9} \text{ ft}^{-1}} \left[\left(\frac{2}{3} (7.28 \times 10^{-9} \text{ ft}^{-1} \cdot 14.5 \text{ ft}) + 1.38 \times 10^{-5} \right)^{\frac{1}{2}} - (1.38 \times 10^{-5})^{\frac{1}{2}} \right]$$

$$L = \frac{3}{7.28 \times 10^{-9} \text{ ft}^{-1}} \left(3.7243 \times 10^{-3} - 3.7148 \times 10^{-3} \right)$$

$$L = 3932 \text{ ft}$$

Attachment A3

Stoller

Calculate height of mound @
West & east midpoint of cell
Bdy

JOB NO.: N/A

DATE: 5-31-07

JOB NAME: MOAB-RAP

PREPARED: ml

REVIEWED:

SHEET NO.: A3-1 OF 13

Summary Page

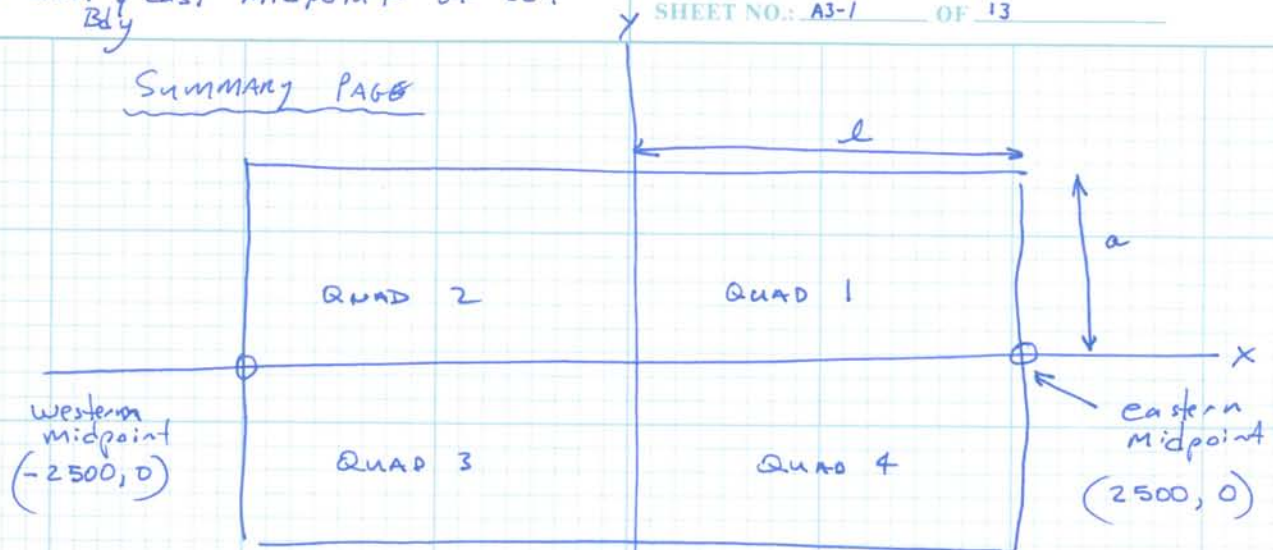

- o Calculate ^{heads} λ for eastern midpoint
- o obtain western midpoint heads by symmetry.

$$K = 124 \text{ ft/yr} @ 10 \text{ yrs} ; h = 2.6 \text{ ft} \quad L = 166 \text{ ft}$$

$$K = 2059 \text{ ft/yr} @ 10 \text{ yrs} ; h = 2.6 \text{ ft} ; L = 718 \text{ ft.}$$

$$K = 124 \text{ ft/yr} @ 200 \text{ yrs} ; h = 11.6 \text{ ft} ; L = 762 \text{ ft}$$

$$K = 2059 \text{ ft/yr} @ 200 \text{ yrs} ; h = 8.69 ; L = 2364 \text{ ft}$$

$$K = 124 \text{ ft/yr} @ 1000 \text{ yrs} ; h = 23.3 \text{ ft} ; L = 1535 \text{ ft.}$$

$$K = 2059 \text{ ft/yr} @ 1000 \text{ yrs} ; h = 13.4 \text{ ft} ; L = 3635 \text{ ft}$$

Stoller

Mounding @ east mid-point of cell
@ 10 yrs for condition; $K=124 \text{ ft/yr}$

JOB NO. N/A

DATE 5-31-07

JOB NAME MOAB RFP

PREPARED: ME

REVIEWED:

DATE NO. 43-2

OF 13

$$K = 124 \text{ ft/yr}$$

compute $h_{(x,y)}$ @ 10 yrs :

$$h^2 = \frac{w}{2K} vt \cdot \left\{ S^* \left(\frac{l+x}{\sqrt{4vt}}, \frac{a+y}{\sqrt{4vt}} \right) + S^* \left(\frac{l+x}{\sqrt{4vt}}, \frac{a-y}{\sqrt{4vt}} \right) + S^* \left(\frac{l-x}{\sqrt{4vt}}, \frac{a+y}{\sqrt{4vt}} \right) + S^* \left(\frac{l-x}{\sqrt{4vt}}, \frac{a-y}{\sqrt{4vt}} \right) \right\}$$

Location $(x, y) =$
 $(2500, 0)$

Recall from Sheet A1-2

$$\sqrt{4vt} = 182 \text{ ft}$$

$$\frac{w}{2K} = 827 \text{ ft}^2/\text{yr}$$

$$\textcircled{A} \quad S^* \left(\frac{2500+x}{\sqrt{4vt}}, \frac{1100+y}{\sqrt{4vt}} \right) = S^* \left(\frac{5000 \text{ ft}}{182 \text{ ft}}, \frac{1100 \text{ ft}}{182 \text{ ft}} \right) = S^*(27.5, 6.04) = 1 \text{ (per Hantush)}$$

$$\textcircled{B} \quad S^* \left(\frac{2500+x}{\sqrt{4vt}}, \frac{1100-y}{\sqrt{4vt}} \right) = S^* \left(\frac{5000 \text{ ft}}{182 \text{ ft}}, \frac{1100 \text{ ft}}{182 \text{ ft}} \right) = S^*(27.5, 6.04) = 1 \text{ (per Hantush)}$$

$$\textcircled{C} \quad S^* \left(\frac{2500-x}{\sqrt{4vt}}, \frac{1100+y}{\sqrt{4vt}} \right) = S^* \left(\frac{0 \text{ ft}}{182 \text{ ft}}, \frac{1100 \text{ ft}}{182 \text{ ft}} \right) = S(0, 6.04) = 0 \text{ (per Hantush)}$$

$$\textcircled{D} \quad S^* \left(\frac{2500-x}{\sqrt{4vt}}, \frac{1100-y}{\sqrt{4vt}} \right) = S^* \left(\frac{0 \text{ ft}}{182 \text{ ft}}, \frac{1100 \text{ ft}}{182 \text{ ft}} \right) = S(0, 6.04) = 0 \text{ (per Hantush)}$$

$$h^2 = \frac{0.103 \text{ ft/yr}}{2 (124 \text{ ft/yr})} (827 \text{ ft}^2/\text{yr}) (10 \text{ yr}) (1 + 1 + 0 + 0)$$

$$h^2 = 6.87 \text{ ft}^2$$

$$h = 2.6 \text{ ft}$$

Stoller

Mounding @ east midpoint of cell
 @ 10 yrs for condition $K = 2059 \text{ ft/yr}$.

$K = 2059 \text{ ft/yr}$

Compute $h_{(x,y)}$ @ 10 yrs :

coordinate $(x,y) = (2500, 0)$

$$h^2 = \frac{w}{2K} vt \cdot \left\{ S^* \left(\frac{l+x}{\sqrt{4vt}}, \frac{a+y}{\sqrt{4vt}} \right) + S^* \left(\frac{l+x}{\sqrt{4vt}}, \frac{a-y}{\sqrt{4vt}} \right) + S^* \left(\frac{l-x}{\sqrt{4vt}}, \frac{a+y}{\sqrt{4vt}} \right) + S^* \left(\frac{l-x}{\sqrt{4vt}}, \frac{a-y}{\sqrt{4vt}} \right) \right\}$$

Recall from sheet A1-2 @ 10 yrs
 $\sqrt{4vt} = 741 \text{ ft}$
 $\frac{1}{2} vt = 13,727 \text{ ft}^2/\text{yr}$

(A) $S^* \left(\frac{2500+x}{\sqrt{4vt}}, \frac{1100+y}{\sqrt{4vt}} \right) = S^* \left(\frac{5000 \text{ ft}}{741 \text{ ft}}, \frac{1100 \text{ ft}}{741 \text{ ft}} \right) = S^*(6.75, 1.48) \approx 1 \text{ (per Hantush)}$

(B) $S^* \left(\frac{2500+x}{\sqrt{4vt}}, \frac{1100-y}{\sqrt{4vt}} \right) = S^* \left(\frac{5000 \text{ ft}}{741 \text{ ft}}, \frac{1100 \text{ ft}}{741 \text{ ft}} \right) = S^*(6.75, 1.48) \approx 1 \text{ (per Hantush)}$

(C) $S^* \left(\frac{2500-x}{\sqrt{4vt}}, \frac{1100+y}{\sqrt{4vt}} \right) = S^* \left(\frac{0 \text{ ft}}{741 \text{ ft}}, \frac{1100 \text{ ft}}{741 \text{ ft}} \right) = S^*(0, 1.48) \approx 0 \text{ per Hantush}$

(D) $S^* \left(\frac{2500-x}{\sqrt{4vt}}, \frac{1100-y}{\sqrt{4vt}} \right) = S^* \left(\frac{0 \text{ ft}}{741 \text{ ft}}, \frac{1100 \text{ ft}}{741 \text{ ft}} \right) = S^*(0, 1.48) \approx 0 \text{ (per Hantush)}$

$$h^2 = \frac{0.103 \text{ ft/yr}}{2 (2059 \text{ ft/yr})} (13,727 \text{ ft}^2/\text{yr}) (10 \text{ yr}) (1 + 1 + 0 + 0)$$

$h^2 = 6.86 \text{ ft}^2$

$h = 2.6 \text{ ft}$

Stoller

Mounding @ east midpoint of cell
@ 200 yrs for condition $K = 124 \text{ ft/yr}$.

JOB NO. N/A

DATE 5-31-07

JOB NAME: MOUND R/R

PREPARED: mm

REVIEWED:

SHEET NO. A3-4

OF 13

$$K = 124 \text{ ft/yr}$$

Compute $h(x,y)$ @ 200 yrs :

$$h^2 = \frac{w}{2K} vt \cdot \left\{ S^* \left(\frac{l+x}{\sqrt{4vt}}, \frac{a+y}{\sqrt{4vt}} \right) + S^* \left(\frac{l+x}{\sqrt{4vt}}, \frac{a-y}{\sqrt{4vt}} \right) + S^* \left(\frac{l-x}{\sqrt{4vt}}, \frac{a+y}{\sqrt{4vt}} \right) \right.$$

Coord location:
 $(x,y) = (2500, 0)$

$$+ S^* \left(\frac{l-x}{\sqrt{4vt}}, \frac{a-y}{\sqrt{4vt}} \right) \left. \right\}$$

Recall from sheet A1-2 ...

$$\sqrt{4vt} = 813 \text{ ft}$$

$$v = 827 \text{ ft}^2/\text{yr}$$

$$\textcircled{A} \quad S^* \left(\frac{2500+x}{\sqrt{4vt}}, \frac{1100+y}{\sqrt{4vt}} \right) = S^* \left(\frac{5000 \text{ ft}}{813 \text{ ft}}, \frac{1100 \text{ ft}}{813 \text{ ft}} \right) = S^*(6.15, 1.35) \approx 0.986 \text{ (per Handbuch of Carslaw \& Jaeger)}$$

$$\textcircled{B} \quad S^* \left(\frac{2500+x}{\sqrt{4vt}}, \frac{1100-y}{\sqrt{4vt}} \right) = S^* \left(\frac{5000 \text{ ft}}{813 \text{ ft}}, \frac{1100 \text{ ft}}{813 \text{ ft}} \right) = S^*(6.15, 1.35) \approx 0.986 \text{ (per Handbuch of Carslaw \& Jaeger)}$$

$$\textcircled{C} \quad S^* \left(\frac{2500-x}{\sqrt{4vt}}, \frac{1100+y}{\sqrt{4vt}} \right) = S^* \left(\frac{0}{813}, \frac{1100}{813} \right) = S^*(0, 1.35) \approx 0 \text{ (per Handbuch)}$$

$$\textcircled{D} \quad S^* \left(\frac{2500-x}{\sqrt{4vt}}, \frac{1100-y}{\sqrt{4vt}} \right) = S^* \left(\frac{0}{813}, \frac{1100}{813} \right) = S^*(0, 1.35) \approx 0 \text{ (per Handbuch)}$$

$$h^2 = \frac{0.103 \text{ ft}^2/\text{yr}}{2 (124 \text{ ft/yr})} (827 \text{ ft}^2/\text{yr}) (200 \text{ yr}) (0.986 + 0.986 + 0 + 0)$$

$$h^2 = 135 \text{ ft}^2$$

$$h = 11.6 \text{ ft}$$

Stoller

Mounding @ east midpoint of cell @ 200 yrs
for condition: $K = 2059 \text{ ft/yr}$

JOB NO: N/A

DATE: 5-31-07

JOB NAME: MOAB RAP

PREPARED: mm

REVIEWED:

SHEET NO: A3-5

OF 13

$$K = 2059 \text{ ft/yr}$$

Compute $h_{(x,y)}$ @ 200 yrs:

$$h^2 = \frac{w}{2K} vt \cdot \left\{ S^* \left(\frac{l+x}{\sqrt{4vt}}, \frac{a+y}{\sqrt{4vt}} \right) + S^* \left(\frac{l+x}{\sqrt{4vt}}, \frac{a-y}{\sqrt{4vt}} \right) + S^* \left(\frac{l-x}{\sqrt{4vt}}, \frac{a+y}{\sqrt{4vt}} \right) \right.$$

(x,y)
location: (2500, 0)

$$+ S^* \left(\frac{l-x}{\sqrt{4vt}}, \frac{a-y}{\sqrt{4vt}} \right) \left. \right\}$$

Recall from Sheet A1-2

$$\sqrt{4vt} = 3314 \text{ ft}$$

$$N = 13,727 \text{ ft}^2/\text{yr}$$

$$\textcircled{A} \quad S^* \left(\frac{2500+x}{\sqrt{4vt}}, \frac{1100+y}{\sqrt{4vt}} \right) = S^* \left(\frac{5000 \text{ ft}}{3314 \text{ ft}}, \frac{1100 \text{ ft}}{3314 \text{ ft}} \right) = S^*(1.51, 0.332) \approx 0.55 \text{ (per Hantush)}$$

$$\textcircled{B} \quad S^* \left(\frac{2500+x}{\sqrt{4vt}}, \frac{1100-y}{\sqrt{4vt}} \right) = S^* \left(\frac{5000 \text{ ft}}{3314 \text{ ft}}, \frac{1100 \text{ ft}}{3314 \text{ ft}} \right) = S^*(1.51, 0.332) \approx 0.55 \text{ (per Hantush)}$$

$$\textcircled{C} \quad S^* \left(\frac{2500-x}{\sqrt{4vt}}, \frac{1100+y}{\sqrt{4vt}} \right) = S^* \left(\frac{0 \text{ ft}}{3314 \text{ ft}}, \frac{1100 \text{ ft}}{3314 \text{ ft}} \right) = S^*(0, 0.332) = 0 \text{ (per Hantush)}$$

$$\textcircled{D} \quad S^* \left(\frac{2500-x}{\sqrt{4vt}}, \frac{1100-y}{\sqrt{4vt}} \right) = S^* \left(\frac{0 \text{ ft}}{3314 \text{ ft}}, \frac{1100 \text{ ft}}{3314 \text{ ft}} \right) = S^*(0, 0.332) = 0 \text{ (per Hantush)}$$

$$h^2 = \frac{0.103 \text{ ft/yr}}{2 (2059 \text{ ft/yr})} (13,727 \text{ ft}^2/\text{yr}) (200 \text{ yr}) \left(\overset{\textcircled{A}}{0.55} + \overset{\textcircled{B}}{0.55} + \overset{\textcircled{C}}{0} + \overset{\textcircled{D}}{0} \right)$$

$$h^2 = 75.5 \text{ ft}^2$$

$$h = 8.69 \text{ ft}$$

Stoller

Mounding @ east mid point of cell
@ 1000 yrs for condition; $K = 124 \text{ ft/yr}$

JOB NO: N/A

DATE: 5-31-07

JOB NAME: MOAB RAP

PREPARED: mm

REVIEWED:

SHEET NO: A3-6

OF 13

$$K = 124 \text{ ft/yr}$$

Compute $h(x,y)$ @ 1000 yrs:

$$h^2 = \frac{w}{2K} vt \cdot \left\{ S^* \left(\frac{l+x}{\sqrt{4vt}}, \frac{a+y}{\sqrt{4vt}} \right) + S^* \left(\frac{l+x}{\sqrt{4vt}}, \frac{a-y}{\sqrt{4vt}} \right) + S^* \left(\frac{l-x}{\sqrt{4vt}}, \frac{a+y}{\sqrt{4vt}} \right) + S^* \left(\frac{l-x}{\sqrt{4vt}}, \frac{a-y}{\sqrt{4vt}} \right) \right\}$$

Recall from Sheet A1-2:

$$\sqrt{4vt} = 1819 \text{ ft}$$

$$l = 827 \text{ ft}$$

Coord Location
 $(x,y) = (2500, 0)$

$$\textcircled{A} \quad S^* \left(\frac{2500+x}{\sqrt{4vt}}, \frac{1100+y}{\sqrt{4vt}} \right) = S^* \left(\frac{5000 \text{ ft}}{1819 \text{ ft}}, \frac{1100 \text{ ft}}{1819 \text{ ft}} \right) = S^*(2.75, 0.605) \approx 0.79 \text{ (per Hantush)}$$

$$\textcircled{B} \quad S^* \left(\frac{2500+x}{\sqrt{4vt}}, \frac{1100-y}{\sqrt{4vt}} \right) = S^* \left(\frac{5000 \text{ ft}}{1819 \text{ ft}}, \frac{1100 \text{ ft}}{1819 \text{ ft}} \right) = S^*(2.75, 0.605) \approx 0.79 \text{ (per Hantush)}$$

$$\textcircled{C} \quad S^* \left(\frac{2500-x}{\sqrt{4vt}}, \frac{1100+y}{\sqrt{4vt}} \right) = S^* \left(\frac{0 \text{ ft}}{1819 \text{ ft}}, \frac{1100 \text{ ft}}{1819 \text{ ft}} \right) = S^*(0, 0.605) = 0 \text{ (per Hantush)}$$

$$\textcircled{D} \quad S^* \left(\frac{2500-x}{\sqrt{4vt}}, \frac{1100-y}{\sqrt{4vt}} \right) = S^* \left(\frac{0 \text{ ft}}{1819 \text{ ft}}, \frac{1100 \text{ ft}}{1819 \text{ ft}} \right) = S^*(0, 0.605) = 0 \text{ (per Hantush)}$$

$$h^2 = \frac{0.103 \text{ ft/yr}}{2 (124 \text{ ft/yr})} \left(827 \text{ ft}^2/\text{yr} \right) (1000 \text{ yr}) \left(\overset{\textcircled{A}}{0.79} + \overset{\textcircled{B}}{0.79} + \overset{\textcircled{C}}{0} + \overset{\textcircled{D}}{0} \right)$$

$$h^2 = 542 \text{ ft}^2$$

$$h = 23.3 \text{ ft.}$$

Stoller

Mounding @ east mid point of cell
 @ 1000 yrs for condition K = 2059 ft/yr

JOB NO N/4

DATE 5-31-07

JOB NAME: MOAB RAP

PREPARED ML

REVIEWED

SHEET NO A3-7

OF 13

$$K = 2059 \text{ ft/yr}$$

Compute $h(x,y)$ @ 1000 yrs :

$$h^2 = \frac{w}{2K} vt \cdot \left\{ S^* \left(\frac{l+x}{\sqrt{4vt}}, \frac{a+y}{\sqrt{4vt}} \right) + S^* \left(\frac{l+x}{\sqrt{4vt}}, \frac{a-y}{\sqrt{4vt}} \right) + S^* \left(\frac{l-x}{\sqrt{4vt}}, \frac{a+y}{\sqrt{4vt}} \right) \right.$$

Coord loc (x,y)
 $= (2500, 0)$

$$+ S^* \left(\frac{l-x}{\sqrt{4vt}}, \frac{a-y}{\sqrt{4vt}} \right) \}$$

Recall from sheet A1-2

$$\sqrt{4vt} = 7410 \text{ ft}$$

$$N = 13,727 \text{ ft}^2/\text{yr}$$

$$\textcircled{A} \quad S^* \left(\frac{2500+x}{\sqrt{4vt}}, \frac{1100+y}{\sqrt{4vt}} \right) = S^* \left(\frac{5000 \text{ ft}}{7410 \text{ ft}}, \frac{1100 \text{ ft}}{7410 \text{ ft}} \right) = S^*(0.675, 0.148) \approx 0.26 \text{ (per Hantush)}$$

$$\textcircled{B} \quad S^* \left(\frac{2500+x}{\sqrt{4vt}}, \frac{1100-y}{\sqrt{4vt}} \right) = S^* \left(\frac{5000 \text{ ft}}{7410 \text{ ft}}, \frac{1100 \text{ ft}}{7410 \text{ ft}} \right) = S^*(0.675, 0.148) \approx 0.26 \text{ (per Hantush)}$$

$$\textcircled{C} \quad S^* \left(\frac{2500-x}{\sqrt{4vt}}, \frac{1100+y}{\sqrt{4vt}} \right) = S^* \left(\frac{0 \text{ ft}}{7410 \text{ ft}}, \frac{1100 \text{ ft}}{7410 \text{ ft}} \right) = S^*(0, 0.148) = 0 \text{ (per Hantush)}$$

$$\textcircled{D} \quad S^* \left(\frac{2500-x}{\sqrt{4vt}}, \frac{1100-y}{\sqrt{4vt}} \right) = S^* \left(\frac{0 \text{ ft}}{7410 \text{ ft}}, \frac{1100 \text{ ft}}{7410 \text{ ft}} \right) = S^*(0, 0.148) = 0 \text{ (per Hantush)}$$

$$h^2 = \frac{0.103 \text{ ft/yr}}{2 (2059 \text{ ft/yr})} (13,727 \text{ ft}^2/\text{yr}) (1000 \text{ yr}) \left(\overset{\textcircled{A}}{0.26} + \overset{\textcircled{B}}{0.26} + \overset{\textcircled{C}}{0} + \overset{\textcircled{D}}{0} \right)$$

$$h^2 = 178 \text{ ft}^2$$

$$h = 13.4 \text{ ft}$$

Stoller

Length of Spreading of Leachate @ 10 yrs
from edge of disposal cell
leachate center (2500, 0)

JOB NO.: N/A

DATE: 5-31-07

JOB NAME: Monb RAP

PREPARED: *me*

REVIEWED: _____

SHEET NO.: A3-8 OF 13

$$L = \frac{3}{A} \left[\left(\frac{2}{3} A h_0 + B \right)^{1/2} - B^{1/2} \right] \quad \text{from Bear, (1979; p. 181-183)} \\ \text{eqn 5-219}$$

$$\text{Let } K = 124 \text{ ft/yr}$$

$$A = \frac{1}{K \sigma'} ; \sigma' = \frac{B'}{K'}$$

$$\therefore \sigma' = \frac{2400 \text{ ft}}{0.036 \text{ ft/yr}} = 6.67 \times 10^4 \text{ yr}$$

where B' = thickness of semipermeous unit (2400 ft)

K' = hydraulic conductivity of semipermeous unit

$$K' = 0.036 \text{ ft/yr}$$

h_0 = head at edge of disposal cell

$$A = \frac{1}{(124 \text{ ft/yr})(6.67 \times 10^4 \text{ yr})}$$

$$A = 1.21 \times 10^{-7} \text{ ft}^{-1}$$

$$\text{Assume } N = (0.01) * (\text{avg. annual pcp.}) = 7.5 \times 10^{-3} \text{ ft/yr} \approx N$$

$$B = \frac{B' - N \sigma'}{K \sigma'} = \frac{2400 \text{ ft} - (7.5 \times 10^{-3} \text{ ft/yr} \cdot 6.67 \times 10^4 \text{ yr})}{(124 \text{ ft/yr})(6.67 \times 10^4 \text{ yr})}$$

$$B = 2.30 \times 10^{-4} \text{ dim}$$

$$L = \frac{3}{1.21 \times 10^{-7} \text{ ft}^{-1}} \left[\left(\frac{2}{3} (1.21 \times 10^{-7} \text{ ft}^{-1} \cdot 2.6 \text{ ft}) + 2.30 \times 10^{-4} \right)^{1/2} + (2.30 \times 10^{-4})^{1/2} \right]$$

$$L = \frac{3}{1.21 \times 10^{-7} \text{ ft}^{-1}} \left(1.5173 \times 10^{-2} - 1.5166 \times 10^{-2} \right)$$

$$L = 166 \text{ ft}$$

Stoller

Length of Spreading of Leachate @ 10 yrs
from edge of disposal cell
Eastern Center (2500, 0)

JOB NO. N/A

DATE 5-31-07

JOB CODE Moab RAP

PREPARED *mm*

REVIEWED

SHEET NO. A3-9

13

$$L = \frac{3}{A} \left[\left(\frac{2}{3} A h_0 + B \right)^{1/2} - B^{1/2} \right] \quad \text{from Bear, (1979; p. 181-183)} \\ \text{eqn 5-219)}$$

$$\text{Let } K = 124 \text{ ft/yr}$$

$$A = \frac{1}{K \sigma'} ; \sigma' = \frac{B'}{K'}$$

where B' = thickness of semipervious unit (2400 ft)

K' = hydraulic conductivity of semipervious unit

$$\therefore \sigma' = \frac{2400 \text{ ft}}{0.036 \text{ ft/yr}} = 6.67 \times 10^4 \text{ yr}$$

$$K' = 0.036 \text{ ft/yr}$$

h_0 = head at edge of disposal cell

$$A = \frac{1}{(124 \text{ ft/yr})(6.67 \times 10^4 \text{ yr})}$$

$$A = 1.21 \times 10^{-7} \text{ ft}^{-1}$$

$$\text{Assume } N = (0.01) * (\text{avg. annual pcp.}) = 7.5 \times 10^{-3} \text{ ft/yr} \approx N$$

$$B = \frac{B' - N \sigma'}{K \sigma'} = \frac{2400 \text{ ft} - (7.5 \times 10^{-3} \text{ ft/yr} \cdot 6.67 \times 10^4 \text{ yr})}{(124 \text{ ft/yr})(6.67 \times 10^4 \text{ yr})}$$

$$B = 2.30 \times 10^{-4} \text{ dim}$$

$$L = \frac{3}{1.21 \times 10^{-7} \text{ ft}^{-1}} \left[\left(\frac{2}{3} (1.21 \times 10^{-7} \text{ ft}^{-1} \cdot 11.6 \text{ ft}) + 2.30 \times 10^{-4} \right)^{1/2} + (2.30 \times 10^{-4})^{1/2} \right]$$

$$L = \frac{3}{1.21 \times 10^{-7} \text{ ft}^{-1}} \left(1.5197 \times 10^{-2} - 1.5166 \times 10^{-2} \right)$$

$$L = 762 \text{ ft}$$

Stoller

Length of Spreading of Leachate @ 10yrs
from edge of disposal cell
Eastern Center (2600, 0)

JOB NO. N/A

DATE 5-31-07

JOB CASE Manab RAP

PREPARED BY me

REVIEWED

SHEET NO. AS-10

13

$$L = \frac{3}{A} \left[\left(\frac{2}{3} A h_0 + B \right)^{1/2} - B^{1/2} \right] \quad \text{from Bear, (1979; p. 181-183)} \\ \text{eqn 5-219)}$$

$$\text{Let } K = 124 \text{ ft/yr}$$

$$A = \frac{1}{K \sigma'} ; \sigma' = \frac{B'}{K'}$$

where B' = thickness of semipervious unit (2400 ft)

K' = hydraulic conductivity of semipervious unit

$$\therefore \sigma' = \frac{2400 \text{ ft}}{0.036 \text{ ft/yr}} = 6.67 \times 10^4 \text{ yr}$$

$$K' = 0.036 \text{ ft/yr}$$

h_0 = head at edge of disposal cell

$$A = \frac{1}{(124 \text{ ft/yr})(6.67 \times 10^4 \text{ yr})}$$

$$A = 1.21 \times 10^{-7} \text{ ft}^{-1}$$

$$\text{Assume } N = (0.01) * (\text{avg. annual pcp.}) = 7.5 \times 10^{-3} \text{ ft/yr} \approx N$$

$$B = \frac{B' - N \sigma'}{K \sigma'} = \frac{2400 \text{ ft} - (7.5 \times 10^{-3} \text{ ft/yr} \cdot 6.67 \times 10^4 \text{ yr})}{(124 \text{ ft/yr})(6.67 \times 10^4 \text{ yr})}$$

$$B = 2.30 \times 10^{-4} \text{ dim}$$

$$L = \frac{3}{1.21 \times 10^{-7} \text{ ft}^{-1}} \left[\left(\frac{2}{3} (1.21 \times 10^{-7} \text{ ft}^{-1} \cdot 23.3 \text{ ft}) + 2.30 \times 10^{-4} \right)^{1/2} + (2.30 \times 10^{-4})^{1/2} \right]$$

$$L = \frac{3}{1.21 \times 10^{-7} \text{ ft}^{-1}} \left(1.5228 \times 10^{-2} - 1.5166 \times 10^{-2} \right)$$

$$L = 1535 \text{ ft}$$

Stoller

Length of Spreading of Leachate @ 10 yrs
from edge of disposal cell
center of center.

JOB NO.: N/A DATE: 5-31-07

JOB NAME: MOAS RAP

PREPARED: ma REVIEWED:

SHEET NO.: A3-11 OF 13

$$L = \frac{3}{A} \left[\left(\frac{2}{3} A h_0 + B \right)^{\frac{1}{2}} - B^{\frac{1}{2}} \right] \quad \text{from Bear (1979; p 181-183; Equation 5-219)}$$

Let $K = 2059 \text{ ft/yr}$

$$A = \frac{1}{K \sigma'} ; \sigma' = \frac{B'}{K'}$$

where B' = thickness of semipervious unit (2400 ft)
 K' = hydraulic conductivity of semipervious unit

$$\sigma' = \frac{2400 \text{ ft}}{0.036 \text{ ft/yr}} = 6.67 \times 10^4 \text{ yr}$$

$$K' = 0.036 \text{ ft/yr}$$

h_0 = head at edge of disposal cell

$$A = \frac{1}{(2059 \text{ ft/yr})(6.67 \times 10^4 \text{ yr})} = \boxed{7.28 \times 10^{-9} \text{ ft}^{-1} = A}$$

Assume $N = 0.01 * (\text{avg. annual pcpr}) = \boxed{7.5 \times 10^{-3} \text{ ft/yr} \approx N}$

$$B = \frac{B' - N \sigma'}{K \sigma'} = \frac{2400 \text{ ft} - (7.5 \times 10^{-3} \text{ ft/yr} \cdot 6.67 \times 10^4 \text{ yr})}{(2059 \text{ ft/yr})(6.67 \times 10^4 \text{ yr})}$$

$$\boxed{B = 1.38 \times 10^{-5} \text{ dim}}$$

$$L = \frac{3}{7.28 \times 10^{-9} \text{ ft}^{-1}} \left[\left(\frac{2}{3} (7.28 \times 10^{-9} \text{ ft}^{-1} \cdot 2.6 \text{ ft}) + 1.38 \times 10^{-5} \right)^{\frac{1}{2}} - (1.38 \times 10^{-5})^{\frac{1}{2}} \right]$$

$$L = \frac{3}{7.28 \times 10^{-9} \text{ ft}^{-1}} (3.7165 \times 10^{-3} - 3.7148 \times 10^{-3})$$

$$L = 718 \text{ ft.}$$

Stoller

Length of Spreading of Leachate @ 10 yrs
from edge of disposal cell
center of eastern.

DATE: N/A

DATE: 5-31-07

JOB NAME: Moab RAP

PREPARED BY: mm

REVISION:

DATE: A3-12 BY: 13

$$L = \frac{3}{A} \left[\left(\frac{2}{3} A h_0 + B \right)^{\frac{1}{2}} - B^{\frac{1}{2}} \right] \quad \text{from Bear (1979; p 181-183; Equation 5-219)}$$

$$\text{Let } K = 2059 \text{ ft/yr}$$

$$A = \frac{1}{K \sigma'} ; \sigma' = \frac{B'}{K'}$$

where B' = thickness of semipervious unit (2400 ft)
 K' = hydraulic conductivity of semipervious unit

$$\sigma' = \frac{2400 \text{ ft}}{0.036 \text{ ft/yr}} = 6.67 \times 10^4 \text{ yr}$$

$$K' = 0.036 \text{ ft/yr}$$

h_0 = head at edge of disposal cell

$$A = \frac{1}{(2059 \text{ ft/yr})(6.67 \times 10^4 \text{ yr})} = \boxed{7.28 \times 10^{-9} \text{ ft}^{-1} = A}$$

$$\text{Assume } N = 0.01 * (\text{avg. annual pcpr}) = \boxed{7.5 \times 10^{-3} \text{ ft/yr} \approx N}$$

$$B = \frac{B' - N \sigma'}{K \sigma'} = \frac{2400 \text{ ft} - (7.5 \times 10^{-3} \text{ ft/yr} \cdot 6.67 \times 10^4 \text{ yr})}{(2059 \text{ ft/yr})(6.67 \times 10^4 \text{ yr})}$$

$$\boxed{B = 1.38 \times 10^{-5} \text{ dim}}$$

$$L = \frac{3}{7.28 \times 10^{-9} \text{ ft}^{-1}} \left[\left(\frac{2}{3} (7.28 \times 10^{-9} \text{ ft}^{-1} \cdot 8.69 \text{ ft}) + 1.38 \times 10^{-5} \right)^{\frac{1}{2}} - (1.38 \times 10^{-5})^{\frac{1}{2}} \right]$$

$$L = \frac{3}{7.28 \times 10^{-9} \text{ ft}^{-1}} (3.7205 \times 10^{-3} - 3.7148 \times 10^{-3})$$

$$L = 2364 \text{ ft}$$

Stoller

Length of Spreading of Leachate @ 10 yrs
from edge of disposal cell
(center of center).

JOB NO. N/A

DATE 5-31-07

JOB NAME MOAB RAP

PREPARED ma

REVIEWED

APP. NO. A3-13

13

$$L = \frac{3}{A} \left[\left(\frac{2}{3} A h_0 + B \right)^{1/2} - B^{1/2} \right] \quad \text{from Bear (1979; p 181-183; Equation 5-219)}$$

$$\text{Let } K = 2059 \text{ ft/yr}$$

$$A = \frac{1}{K \sigma'} ; \sigma' = \frac{B'}{K'}$$

where B' = thickness of semipermeous unit (2400 ft)
 K' = hydraulic conductivity of semipermeous unit

$$\sigma' = \frac{2400 \text{ ft}}{0.036 \text{ ft/yr}} = 6.67 \times 10^4 \text{ yr}$$

$$K' = 0.036 \text{ ft/yr}$$

h_0 = head at edge of disposal cell

$$A = \frac{1}{(2059 \text{ ft/yr})(6.67 \times 10^4 \text{ yr})} = 7.28 \times 10^{-9} \text{ ft}^{-1} = A$$

$$\text{Assume } N = 0.01 * (\text{avg. annual pcpr}) = 7.5 \times 10^{-3} \text{ ft/yr} \approx N$$

$$B = \frac{B' - N \sigma'}{K \sigma'} = \frac{2400 \text{ ft} - (7.5 \times 10^{-3} \text{ ft/yr} \cdot 6.67 \times 10^4 \text{ yr})}{(2059 \text{ ft/yr})(6.67 \times 10^4 \text{ yr})}$$

$$B = 1.38 \times 10^{-5} \text{ dim}$$

$$L = \frac{3}{7.28 \times 10^{-9} \text{ ft}^{-1}} \left[\left(\frac{2}{3} (7.28 \times 10^{-9} \text{ ft}^{-1} \cdot 13.4 \text{ ft}) + 1.38 \times 10^{-5} \right)^{1/2} - (1.38 \times 10^{-5})^{1/2} \right]$$

$$L = \frac{3}{7.28 \times 10^{-9} \text{ ft}^{-1}} \left(3.7236 \times 10^{-3} - 3.7148 \times 10^{-3} \right)$$

$$L = 3635 \text{ ft}$$

Attachment A4

Stoller

Calculate height of mound @
corner of Quadrant 1

JOB NO.: N/A DATE: 5-31-07

JOB NAME: MOAB-RIP

PREPARED: *mm* REVIEWED: _____

SHEET NO.: AA-1 OF 13

Summary Page

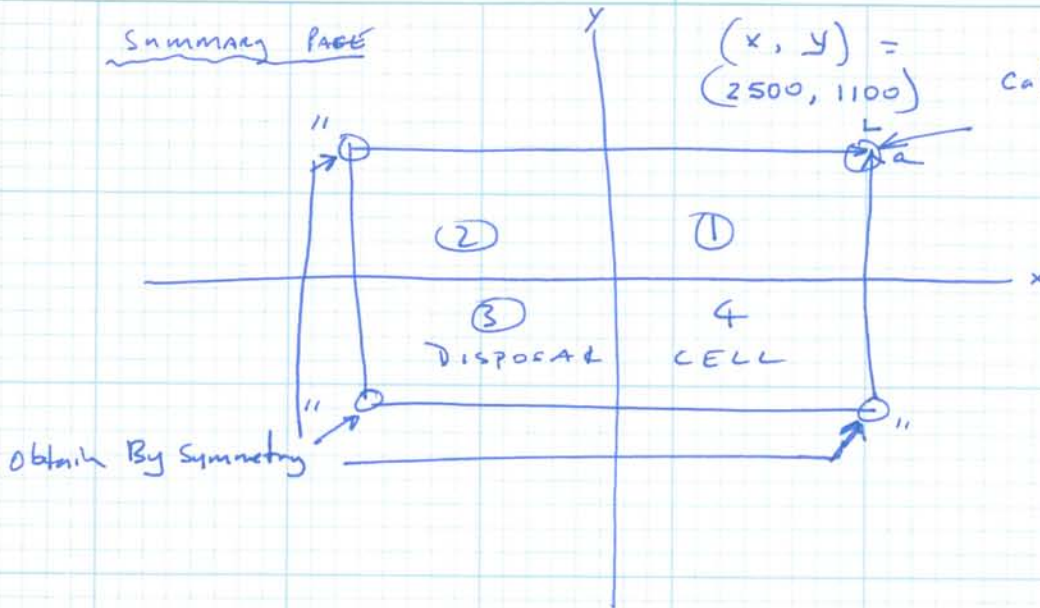

calculate h at corner
of Quadrant 1,
obtain all other h
@ corners by
symmetry

$$K = 124 \text{ ft/yr. @ } 10 \text{ yrs ; } h = 1.8 \text{ ft ; } L = 113 \text{ ft}$$

$$K = 2059 \text{ ft/yr @ } 10 \text{ yrs ; } h = 1.8 \text{ ft ; } L = 501 \text{ ft}$$

$$K = 124 \text{ ft/yr @ } 200 \text{ yrs ; } h = 8.3 \text{ ft. ; } L = 543 \text{ ft}$$

$$K = 2059 \text{ ft/yr @ } 200 \text{ yrs ; } h = 7.5 \text{ ft ; } L = 2042 \text{ ft}$$

$$K = 124 \text{ ft/yr @ } 1000 \text{ yrs ; } h = 18.2 \text{ ft ; } L = 1198 \text{ ft}$$

$$K = 2059 \text{ ft/yr @ } 1000 \text{ yrs ; } h = 12.3 \text{ ft. ; } L = 3338 \text{ ft}$$

Stoller

Calculate mound @ corner of cell @ 10%
obtain all other corner values of h by symmetry.

JOB NO.: N/A

DATE: 5-31-07

JOB NAME: MOAB RAP

PREPARED: mm

REVIEWED:

SHEET NO. AA-2

13

$$K = 124 \text{ ft/yr}$$

compute $h_{(x,y)}$ @ 10 yrs :

$$h^2 = \frac{\omega}{2K} vt \cdot \left\{ S^* \left(\frac{l+x}{\sqrt{4vt}}, \frac{a+y}{\sqrt{4vt}} \right) + S^* \left(\frac{l+x}{\sqrt{4vt}}, \frac{a-y}{\sqrt{4vt}} \right) + S^* \left(\frac{l-x}{\sqrt{4vt}}, \frac{a+y}{\sqrt{4vt}} \right) \right.$$

For $(x,y) =$
 $(2500, 1100)$

$$+ S^* \left(\frac{l-x}{\sqrt{4vt}}, \frac{a-y}{\sqrt{4vt}} \right) \}$$

Recall from Sheet A1-2

$$\sqrt{4vt} = 182 \text{ ft}$$

$$f N = 827 \text{ ft}^2/\text{yr}$$

$$\textcircled{A} S^* \left(\frac{2500+x}{\sqrt{4vt}}, \frac{1100+y}{\sqrt{4vt}} \right) = S^* \left(\frac{5000 \text{ ft}}{182 \text{ ft}}, \frac{2200 \text{ ft}}{182 \text{ ft}} \right) = S^* (27.5, 12.1) = 1 \text{ (per Handbuch)}$$

$$\textcircled{B} S^* \left(\frac{2500+x}{\sqrt{4vt}}, \frac{1100-y}{\sqrt{4vt}} \right) = S^* \left(\frac{5000 \text{ ft}}{182 \text{ ft}}, \frac{0 \text{ ft}}{182 \text{ ft}} \right) = S^* (27.5, 0) = 0 \text{ (per Handbuch)}$$

$$\textcircled{C} S^* \left(\frac{2500-x}{\sqrt{4vt}}, \frac{1100+y}{\sqrt{4vt}} \right) = S^* \left(\frac{0 \text{ ft}}{182 \text{ ft}}, \frac{2200 \text{ ft}}{182 \text{ ft}} \right) = S^* (0, 12.1) = 0 \text{ (per Handbuch)}$$

$$\textcircled{D} S^* \left(\frac{2500-x}{\sqrt{4vt}}, \frac{1100-y}{\sqrt{4vt}} \right) = S^* \left(\frac{0 \text{ ft}}{182 \text{ ft}}, \frac{0 \text{ ft}}{182 \text{ ft}} \right) = S^* (0, 0) = 0 \text{ (per Handbuch)}$$

$$h^2 = \frac{0.103 \text{ ft/yr}}{2 (124 \text{ ft/yr})} (827 \text{ ft}^2/\text{yr}) (10 \text{ yr}) \left(\begin{matrix} \textcircled{A} & \textcircled{B} & \textcircled{C} & \textcircled{D} \\ 1 & + & 0 & + & 0 & + & 0 & + & 0 \end{matrix} \right)$$

$$h^2 = 3.43 \text{ ft}^2$$

$$h = 1.8 \text{ ft}$$

Stoller

Mounding @ corner of cell @ 10 yrs
for condition: $K = 2059 \text{ ft/yr}$

JOB NO. N/A

DATE 5-31-07

JOB NAME MOAB RAT

PREPARED *mm*

REVIEWED:

SHEET NO. A4-3 OF 13

$$K = 2059 \text{ ft/yr}$$

Compute $h_{(x,y)}$ @ 10 yrs:

$$h^2 = \frac{w}{2K} vt \cdot \left\{ S^* \left(\frac{l+x}{\sqrt{4vt}}, \frac{a+y}{\sqrt{4vt}} \right) + S^* \left(\frac{l-x}{\sqrt{4vt}}, \frac{a-y}{\sqrt{4vt}} \right) + S^* \left(\frac{l-x}{\sqrt{4vt}}, \frac{a+y}{\sqrt{4vt}} \right) \right.$$

$$\textcircled{A} (x,y) = (2500, 1100)$$

$$\left. + S^* \left(\frac{l-x}{\sqrt{4vt}}, \frac{a-y}{\sqrt{4vt}} \right) \right\}$$

Recall from sheet A1-2

$$\sqrt{4vt} = 761 \text{ ft}$$

$$w = 13,727 \text{ ft}^2/\text{yr}$$

$$\textcircled{A} S^* \left(\frac{2500+x}{\sqrt{4vt}}, \frac{1100+y}{\sqrt{4vt}} \right) = S^* \left(\frac{5000 \text{ ft}}{761 \text{ ft}}, \frac{2200 \text{ ft}}{761 \text{ ft}} \right) = S^* (6.57, 2.89) \approx 1 \text{ per Hantush \& Carlson \& Jaeger}$$

$$\textcircled{B} S^* \left(\frac{2500+x}{\sqrt{4vt}}, \frac{1100-y}{\sqrt{4vt}} \right) = S^* \left(\frac{5000 \text{ ft}}{761 \text{ ft}}, \frac{0 \text{ ft}}{761 \text{ ft}} \right) = 0 \text{ per Hantush}$$

$$\textcircled{C} S^* \left(\frac{2500-x}{\sqrt{4vt}}, \frac{1100+y}{\sqrt{4vt}} \right) = S^* \left(\frac{0 \text{ ft}}{761 \text{ ft}}, \frac{2200 \text{ ft}}{761 \text{ ft}} \right) = S^* (0, 2.89) = 0 \text{ (per Hantush)}$$

$$\textcircled{D} S^* \left(\frac{2500-x}{\sqrt{4vt}}, \frac{1100-y}{\sqrt{4vt}} \right) = S^* \left(\frac{0 \text{ ft}}{761 \text{ ft}}, \frac{0 \text{ ft}}{761 \text{ ft}} \right) = S^* (0, 0) = 0 \text{ per Hantush}$$

$$h^2 = \frac{0.103 \text{ ft/yr}}{2 (2059 \text{ ft/yr})} (13,727 \text{ ft}^2/\text{yr}) (10 \text{ yr}) \left(\textcircled{A} 1 + \textcircled{B} 0 + \textcircled{C} 0 + \textcircled{D} 0 \right)$$

$$h^2 = 3.43 \text{ ft}^2$$

$$h = 1.8 \text{ ft}$$

Stoller

Mounding @ corner of cell @ 200 yrs
for condition $K = 124 \text{ ft/yr}$

JOB NO: N/A

DATE: 5-31-07

JOB NAME: MOAB RAP

PREPARED: mm

REVIEWED:

SHEET NO: A4-4 OF 13

$$K = 124 \text{ ft/yr}$$

Compute $h(x,y)$ @ 200 yrs:

$$h^2 = \frac{\omega}{2K} vt \cdot \left\{ S^* \left(\frac{l+x}{\sqrt{4vt}}, \frac{a+y}{\sqrt{4vt}} \right) + S^* \left(\frac{l+x}{\sqrt{4vt}}, \frac{a-y}{\sqrt{4vt}} \right) + S^* \left(\frac{l-x}{\sqrt{4vt}}, \frac{a+y}{\sqrt{4vt}} \right) \right.$$

Corner location @
 $C(x,y) = (2500, 1100)$

$$+ S^* \left(\frac{l-x}{\sqrt{4vt}}, \frac{a-y}{\sqrt{4vt}} \right) \}$$

Recall sheet A1-2

$$\sqrt{4vt} = 813 \text{ ft}$$

$$N = 827 \text{ ft}^2/\text{yr}$$

$$\textcircled{A} \quad S^* \left(\frac{2500+x}{\sqrt{4vt}}, \frac{1100+y}{\sqrt{4vt}} \right) = S^* \left(\frac{5000 \text{ ft}}{827 \text{ ft}}, \frac{2200 \text{ ft}}{827 \text{ ft}} \right) = S^*(6.04, 2.66) \approx 1 \text{ (per Hundtash \& Carlsaw \& Jaeger)}$$

$$\textcircled{B} \quad S^* \left(\frac{2500+x}{\sqrt{4vt}}, \frac{1100-y}{\sqrt{4vt}} \right) = S^* \left(\frac{5000 \text{ ft}}{827 \text{ ft}}, \frac{0 \text{ ft}}{827 \text{ ft}} \right) = S^*(6.04, 0) = 0 \text{ (per Hundtash)}$$

$$\textcircled{C} \quad S^* \left(\frac{2500-x}{\sqrt{4vt}}, \frac{1100+y}{\sqrt{4vt}} \right) = S^* \left(\frac{0 \text{ ft}}{827 \text{ ft}}, \frac{2200 \text{ ft}}{827 \text{ ft}} \right) = S^*(0, 2.66) = 0 \text{ (per Hundtash)}$$

$$\textcircled{D} \quad S^* \left(\frac{2500-x}{\sqrt{4vt}}, \frac{1100-y}{\sqrt{4vt}} \right) = S^* \left(\frac{0 \text{ ft}}{827 \text{ ft}}, \frac{0 \text{ ft}}{827 \text{ ft}} \right) = S^*(0, 0) = 0 \text{ (per Hundtash)}$$

$$h^2 = \frac{0.103 \text{ ft}^2/\text{yr}}{2 (124 \text{ ft/yr})} (827 \text{ ft}^2/\text{yr}) (200 \text{ yr}) \left(\textcircled{A} + \textcircled{B} + \textcircled{C} + \textcircled{D} \right)$$

$$h^2 = 68.7 \text{ ft}^2$$

$$h = 8.3 \text{ ft.}$$

Stoller

Mounding @ corner of cell @ 200 yrs
for conditions: $K = 2059 \text{ ft/yr}$

JOB NO. N/A

DATE 8-31-07

JOB NAME: MOAB RAP

PREPARED: nm

REVIEWED:

SHEET NO. A4-5 OF 13

$$K = 2059 \text{ ft/yr}$$

compute $h_{(x,y)}$ @ 200 yrs:

$$h^2 = \frac{w}{2K} vt \cdot \left\{ S^* \left(\frac{l+x}{\sqrt{4vt}}, \frac{a+y}{\sqrt{4vt}} \right) + S^* \left(\frac{l+x}{\sqrt{4vt}}, \frac{a-y}{\sqrt{4vt}} \right) + S^* \left(\frac{l-x}{\sqrt{4vt}}, \frac{a+y}{\sqrt{4vt}} \right) \right.$$

location $(x,y) =$
 $(2500, 1100)$

$$+ S^* \left(\frac{l-x}{\sqrt{4vt}}, \frac{a-y}{\sqrt{4vt}} \right) \}$$

Recall from Sheet A1-2

$$\sqrt{4vt} = 3314 \text{ ft}$$

$$\phi v = 13,727 \text{ ft}^2/\text{yr}$$

$$\textcircled{A} S^* \left(\frac{2500+x}{\sqrt{4vt}}, \frac{1100+y}{\sqrt{4vt}} \right) = S^* \left(\frac{5000 \text{ ft}}{3314 \text{ ft}}, \frac{2200 \text{ ft}}{3314 \text{ ft}} \right) = S^*(1.51, 0.664) \approx 0.82 \text{ (per Hantush)}$$

$$\textcircled{B} S^* \left(\frac{2500+x}{\sqrt{4vt}}, \frac{1100-y}{\sqrt{4vt}} \right) = S^* \left(\frac{5000 \text{ ft}}{3314 \text{ ft}}, \frac{0 \text{ ft}}{3314 \text{ ft}} \right) = S^*(1.51, 0) = 0 \text{ (per Hantush)}$$

$$\textcircled{C} S^* \left(\frac{2500-x}{\sqrt{4vt}}, \frac{1100+y}{\sqrt{4vt}} \right) = S^* \left(\frac{0 \text{ ft}}{3314 \text{ ft}}, \frac{2200 \text{ ft}}{3314 \text{ ft}} \right) = S^*(0, 0.664) = 0 \text{ (per Hantush)}$$

$$\textcircled{D} S^* \left(\frac{2500-x}{\sqrt{4vt}}, \frac{1100-y}{\sqrt{4vt}} \right) = S^* \left(\frac{0 \text{ ft}}{3314 \text{ ft}}, \frac{0 \text{ ft}}{3314 \text{ ft}} \right) = S^*(0, 0) = 0 \text{ (per Hantush)}$$

$$h^2 = \frac{0.103 \text{ ft/yr}}{2 (2059 \text{ ft/yr})} (13,727 \text{ ft}^2/\text{yr}) (200 \text{ yr}) \left(\overset{\textcircled{A}}{0.82} + \overset{\textcircled{B}}{0} + \overset{\textcircled{C}}{0} + \overset{\textcircled{D}}{0} \right)$$

$$h^2 = 56.3 \text{ ft}^2$$

$$h = 7.50 \text{ ft}$$

Stoller

Calculate mound @ corner of cell @ 1000 yrs:
for condition: $K = 124 \text{ ft/yr}$

JOB NO: N/4

DATE: 5-31-07

JOB NAME: MOAB RAR

PREPARED: mm

REVIEWED:

SHEET NO: A4-6 OF 13

$$K = 124 \text{ ft/yr}$$

compute $h_{(x,y)}$ @ 1000 yrs:

$$h^2 = \frac{w}{2K} vt \cdot \left\{ S^* \left(\frac{l+x}{\sqrt{4vt}}, \frac{a+y}{\sqrt{4vt}} \right) + S^* \left(\frac{l+x}{\sqrt{4vt}}, \frac{a-y}{\sqrt{4vt}} \right) + S^* \left(\frac{l-x}{\sqrt{4vt}}, \frac{a+y}{\sqrt{4vt}} \right) \right.$$

$$\left. \begin{aligned} \text{Location } (x,y) = \\ (2500, 1100) \end{aligned} \right\} + S^* \left(\frac{l-x}{\sqrt{4vt}}, \frac{a-y}{\sqrt{4vt}} \right)$$

Recall from sheet A1-2

$$\sqrt{4vt} = 1819 \text{ ft}$$

$$\left\{ \begin{aligned} w &= 827 \text{ ft}^2/\text{yr} \end{aligned} \right.$$

$$\textcircled{A} \quad S^* \left(\frac{2500+x}{\sqrt{4vt}}, \frac{1100+y}{\sqrt{4vt}} \right) = S^* \left(\frac{5000 \text{ ft}}{1819 \text{ ft}}, \frac{2200 \text{ ft}}{1819 \text{ ft}} \right) = S^* (2.75, 1.21) = 0.97 \text{ (per Hanfush)}$$

$$\textcircled{B} \quad S^* \left(\frac{2500+x}{\sqrt{4vt}}, \frac{1100-y}{\sqrt{4vt}} \right) = S^* \left(\frac{5000 \text{ ft}}{1819}, \frac{0}{1819 \text{ ft}} \right) = 0 \text{ (per Hanfush)}$$

$$\textcircled{C} \quad S^* \left(\frac{2500-x}{\sqrt{4vt}}, \frac{1100+y}{\sqrt{4vt}} \right) = S^* \left(\frac{0 \text{ ft}}{1819 \text{ ft}}, \frac{2200 \text{ ft}}{1819 \text{ ft}} \right) = 0 \text{ (per Hanfush)}$$

$$\textcircled{D} \quad S^* \left(\frac{2500-x}{\sqrt{4vt}}, \frac{1100-y}{\sqrt{4vt}} \right) = S^* \left(\frac{0 \text{ ft}}{1819 \text{ ft}}, \frac{0 \text{ ft}}{1819 \text{ ft}} \right) = 0 \text{ (per Hanfush)}$$

$$h^2 = \frac{0.103 \text{ ft/yr}}{2 (124 \text{ ft/yr})} (827 \text{ ft}^2/\text{yr}) (1000 \text{ yr}) \left(\begin{matrix} \textcircled{A} & \textcircled{B} & \textcircled{C} & \textcircled{D} \\ 0.97 & + 0 & + 0 & + 0 \end{matrix} \right)$$

$$h^2 = 333 \text{ ft}^2$$

$$h = 18.2 \text{ ft.}$$

Calculate leachate mound @ corner of cell
@ 1000 yrs for condition $K = 2059 \text{ ft/yr}$

Stoller

JOB NO: N/A

DATE: 5-31-07

JOB NAME: MOAB RAP

PREPARED: *mm*

REVIEWED:

SHEET NO: A4-7 OF 15

$$K = 2059 \text{ ft/yr}$$

Compute $h(x,y)$ @ 1000 yrs :

$$h^2 = \frac{w}{2K} vt \cdot \left\{ S^* \left(\frac{l+x}{\sqrt{4vt}}, \frac{a+y}{\sqrt{4vt}} \right) + S^* \left(\frac{l+x}{\sqrt{4vt}}, \frac{a-y}{\sqrt{4vt}} \right) + S^* \left(\frac{l-x}{\sqrt{4vt}}, \frac{a+y}{\sqrt{4vt}} \right) \right.$$

location:
 $(x,y) = (2500, 1100)$

$$+ S^* \left(\frac{l-x}{\sqrt{4vt}}, \frac{a-y}{\sqrt{4vt}} \right) \}$$

Recall from sheet A1-2

$$\sqrt{4vt} = 7410 \text{ ft}$$

$$N = 13,727 \text{ ft}$$

$$\textcircled{A} \quad S^* \left(\frac{2500+x}{\sqrt{4vt}}, \frac{1100+y}{\sqrt{4vt}} \right) = S^* \left(\frac{5000 \text{ ft}}{7410 \text{ ft}}, \frac{2200 \text{ ft}}{7410 \text{ ft}} \right) = S^*(0.675, 0.297) \approx 0.44 \text{ (per Hantush)}$$

$$\textcircled{B} \quad S^* \left(\frac{2500+x}{\sqrt{4vt}}, \frac{1100-y}{\sqrt{4vt}} \right) = S^* \left(\frac{5000 \text{ ft}}{7410 \text{ ft}}, \frac{0 \text{ ft}}{7410 \text{ ft}} \right) = S^*(0.675, 0) = 0 \text{ (per Hantush)}$$

$$\textcircled{C} \quad S^* \left(\frac{2500-x}{\sqrt{4vt}}, \frac{1100+y}{\sqrt{4vt}} \right) = S^* \left(\frac{0 \text{ ft}}{7410 \text{ ft}}, \frac{2200 \text{ ft}}{7410 \text{ ft}} \right) = S^*(0, 0.289) = 0 \text{ (per Hantush)}$$

$$\textcircled{D} \quad S^* \left(\frac{2500-x}{\sqrt{4vt}}, \frac{1100-y}{\sqrt{4vt}} \right) = S^* \left(\frac{0 \text{ ft}}{7410 \text{ ft}}, \frac{0 \text{ ft}}{7410 \text{ ft}} \right) = S^*(0, 0) = 0 \text{ (per Hantush)}$$

$$h^2 = \frac{0.103 \text{ ft/yr}}{2 (2059 \text{ ft/yr})} (13,727 \text{ ft}^2/\text{yr}) (1000 \text{ yr}) \left(\overset{\textcircled{A}}{0.44} + \overset{\textcircled{B}}{0} + \overset{\textcircled{C}}{0} + \overset{\textcircled{D}}{0} \right)$$

$$h^2 = 151 \text{ ft}^2$$

$$h = 12.3 \text{ ft}$$

Stoller

Length of Spreading of Leachate @ 10yrs
from ~~edge~~ of disposal cell
Corner

JOB NO. N/A

DATE 5-31-07

JOB NAME: Moab RAP

PREPARED: me

REVIEWED:

SHEET NO. A4-8 OF 13

$$L = \frac{3}{A} \left[\left(\frac{2}{3} A h_0 + B \right)^{1/2} - B^{1/2} \right] \quad \text{from Bear, (1979; p. 181-183)} \\ \text{eqn 5-219)}$$

$$\text{Let } K = 124 \text{ ft/yr}$$

$$A = \frac{1}{K \sigma'} ; \sigma' = \frac{B'}{K'}$$

where B' = thickness of semipervious unit (2400 ft)

K' = hydraulic conductivity of semipervious unit

$$\therefore \sigma' = \frac{2400 \text{ ft}}{0.036 \text{ ft/yr}} = 6.67 \times 10^4 \text{ yr}$$

$$K' = 0.036 \text{ ft/yr}$$

h_0 = head at edge of disposal cell

$$A = \frac{1}{(124 \text{ ft/yr})(6.67 \times 10^4 \text{ yr})}$$

$$A = 1.21 \times 10^{-7} \text{ ft}^{-1}$$

$$\text{Assume } N = (0.01) * (\text{avg. annual pcp.}) = 7.5 \times 10^{-3} \text{ ft/yr} \approx N$$

$$B = \frac{B' - N \sigma'}{K \sigma'} = \frac{2400 \text{ ft} - (7.5 \times 10^{-3} \text{ ft/yr} \cdot 6.67 \times 10^4 \text{ yr})}{(124 \text{ ft/yr})(6.67 \times 10^4 \text{ yr})}$$

$$B = 2.30 \times 10^{-4} \text{ dim}$$

$$L = \frac{3}{1.21 \times 10^{-7} \text{ ft}^{-1}} \left[\left(\frac{2}{3} (1.21 \times 10^{-7} \text{ ft}^{-1} \cdot 1.8 \text{ ft}) + 2.30 \times 10^{-4} \right)^{1/2} + (2.30 \times 10^{-4})^{1/2} \right]$$

$$L = \frac{3}{1.21 \times 10^{-7} \text{ ft}^{-1}} \left(1.5171 \times 10^{-2} - 1.5166 \times 10^{-2} \right)$$

$$L = 113 \text{ ft}$$

Stoller

Length of Spreading of Leachate @ 200 yrs
from corner of disposal cell

JOB NO. N/A

DATE 5-31-07

JOB NAME Moab RAP

PREPARED: me

REVIEWED:

SHEET NO. A-9

13

$$L = \frac{3}{A} \left[\left(\frac{2}{3} A h_0 + B \right)^{1/2} - B^{1/2} \right] \quad \text{from Bear, (1979; p. 181-183)} \\ \text{eqn 5-219)}$$

$$\text{Let } K = 124 \text{ ft/yr}$$

$$A = \frac{1}{K \sigma'} ; \sigma' = \frac{B'}{K'}$$

where B' = thickness of semipervious unit (2400 ft)

K' = hydraulic conductivity of semipervious unit

$$\therefore \sigma' = \frac{2400 \text{ ft}}{0.036 \text{ ft/yr}} = 6.67 \times 10^4 \text{ yr}$$

$$K' = 0.036 \text{ ft/yr}$$

h_0 = head at edge of disposal cell

$$A = \frac{1}{(124 \text{ ft/yr})(6.67 \times 10^4 \text{ yr})}$$

$$A = 1.21 \times 10^{-7} \text{ ft}^{-1}$$

$$\text{Assume } N = (0.01) * (\text{avg. annual pcp.}) = 7.5 \times 10^{-3} \text{ ft/yr} \approx N$$

$$B = \frac{B' - N \sigma'}{K \sigma'} = \frac{2400 \text{ ft} - (7.5 \times 10^{-3} \text{ ft/yr} \cdot 6.67 \times 10^4 \text{ yr})}{(124 \text{ ft/yr})(6.67 \times 10^4 \text{ yr})}$$

$$B = 2.30 \times 10^{-4} \text{ dim}$$

$$L = \frac{3}{1.21 \times 10^{-7} \text{ ft}^{-1}} \left[\left(\frac{2}{3} (1.21 \times 10^{-7} \text{ ft}^{-1} \cdot 8.3 \text{ ft}) + 2.30 \times 10^{-4} \right)^{1/2} + (2.30 \times 10^{-4})^{1/2} \right]$$

$$L = \frac{3}{1.21 \times 10^{-7} \text{ ft}^{-1}} \left(1.5188 \times 10^{-2} - 1.5166 \times 10^{-2} \right)$$

$$L = 543 \text{ ft}$$

Stoller

Length of Spreading of Leachate @ 1000yrs
from corner of disposal cell

JOB NO: N/A

DATE: 5-31-07

JOB NAME: Moab RAP

PREPARED BY: me

REVIEWED BY:

SHEET NO: A4-10

13

$$L = \frac{3}{A} \left[\left(\frac{2}{3} A h_0 + B \right)^{1/2} - B^{1/2} \right] \quad \text{from Bear, (1979; p. 181-183 egn 5-219)}$$

$$\text{Let } K = 124 \text{ ft/yr}$$

$$A = \frac{1}{K \sigma'} ; \sigma' = \frac{B'}{K'}$$

where B' = thickness of semipervious unit (2400 ft)

K' = hydraulic conductivity of semipervious unit

$$\therefore \sigma' = \frac{2400 \text{ ft}}{0.036 \text{ ft/yr}} = 6.67 \times 10^4 \text{ yr}$$

$$K' = 0.036 \text{ ft/yr}$$

h_0 = head at edge of disposal cell

$$A = \frac{1}{(124 \text{ ft/yr})(6.67 \times 10^4 \text{ yr})}$$

$$A = 1.21 \times 10^{-7} \text{ ft}^{-1}$$

$$\text{Assume } N = (0.01) * (\text{avg. annual pcp.}) = 7.5 \times 10^{-3} \text{ ft/yr} \approx N$$

$$B = \frac{B' - N \sigma'}{K \sigma'} = \frac{2400 \text{ ft} - (7.5 \times 10^{-3} \text{ ft/yr} \cdot 6.67 \times 10^4 \text{ yr})}{(124 \text{ ft/yr})(6.67 \times 10^4 \text{ yr})}$$

$$B = 2.30 \times 10^{-4} \text{ dim}$$

$$L = \frac{3}{1.21 \times 10^{-7} \text{ ft}^{-1}} \left[\left(\frac{2}{3} (1.21 \times 10^{-7} \text{ ft}^{-1} \cdot 18.2 \text{ ft}) + 2.30 \times 10^{-4} \right)^{1/2} + (2.30 \times 10^{-4})^{1/2} \right]$$

$$L = \frac{3}{1.21 \times 10^{-7} \text{ ft}^{-1}} \left(1.5214 \times 10^{-2} - 1.5166 \times 10^{-2} \right)$$

$$L = 1198 \text{ ft}$$

Stoller

Length of Spreading of Leachate @ 10 yrs
from Corner of Disposal cell

JOB NO: N/A

DATE: 5-31-07

JOB NAME: MOAB RAP

PREPARED BY: ma

REVIEWED:

DATE: 4-11 07 13

$$L = \frac{3}{A} \left[\left(\frac{2}{3} A h_0 + B \right)^{\frac{1}{2}} - B^{\frac{1}{2}} \right] \quad \text{from Bear (1979; p 181-183; Equation 5-219)}$$

$$\text{Let } K = 2059 \text{ ft/yr}$$

$$A = \frac{1}{K \sigma'} ; \sigma' = \frac{B'}{K'}$$

where B' = thickness of semipermeous unit (2400 ft)
 K' = hydraulic conductivity of semipermeous unit

$$\sigma' = \frac{2400 \text{ ft}}{0.036 \text{ ft/yr}} = 6.67 \times 10^4 \text{ yr}$$

$$K' = 0.036 \text{ ft/yr}$$

h_0 = head at edge of disposal cell

$$A = \frac{1}{(2059 \text{ ft/yr})(6.67 \times 10^4 \text{ yr})} = 7.28 \times 10^{-9} \text{ ft}^{-1} = A$$

$$\text{Assume } N = 0.01 * (\text{avg. annual pcpr}) = 7.5 \times 10^{-3} \text{ ft/yr} \approx N$$

$$B = \frac{B' - N \sigma'}{K \sigma'} = \frac{2400 \text{ ft} - (7.5 \times 10^{-3} \text{ ft/yr} \cdot 6.67 \times 10^4 \text{ yr})}{(2059 \text{ ft/yr})(6.67 \times 10^4 \text{ yr})}$$

$$B = 1.38 \times 10^{-5} \text{ dim}$$

$$L = \frac{3}{7.28 \times 10^{-9} \text{ ft}^{-1}} \left[\left(\frac{2}{3} (7.28 \times 10^{-9} \text{ ft}^{-1} \cdot 1.8 \text{ ft}) + 1.38 \times 10^{-5} \right)^{\frac{1}{2}} - (1.38 \times 10^{-5})^{\frac{1}{2}} \right]$$

$$L = \frac{3}{7.28 \times 10^{-9} \text{ ft}^{-1}} (3.7160 \times 10^{-3} - 3.7148 \times 10^{-3})$$

$$L = 501 \text{ ft}$$

Stoller

Length of Spreading of Leachate @ 2004s
from Corner of Disposal cell

ISSUED: N/A

DATE: 5-31-07

JOB NAME: MOAG RAP

PREPARED BY: ma

REVIEWED:

REVISED: A4-12 OF 13

$$L = \frac{3}{A} \left[\left(\frac{2}{3} A h_0 + B \right)^{\frac{1}{2}} - B^{\frac{1}{2}} \right] \quad \text{from Bear (1979; p 181-183; Equation 5-219)}$$

$$\text{Let } K = 2059 \text{ ft/yr}$$

$$A = \frac{1}{K \sigma'} ; \sigma' = \frac{B'}{K'}$$

where B' = thickness of semipermeous unit (2400 ft)
 K' = hydraulic conductivity of semipermeous unit

$$\sigma' = \frac{2400 \text{ ft}}{0.036 \text{ ft/yr}} = 6.67 \times 10^4 \text{ yr}$$

$$K' = 0.036 \text{ ft/yr}$$

h_0 = head at edge of disposal cell

$$A = \frac{1}{(2059 \text{ ft/yr})(6.67 \times 10^4 \text{ yr})} = 7.28 \times 10^{-9} \text{ ft}^{-1} = A$$

$$\text{Assume } N = 0.01 * (\text{avg. annual pcpr}) = 7.5 \times 10^{-3} \text{ ft/yr} \approx N$$

$$B = \frac{B' - N \sigma'}{K \sigma'} = \frac{2400 \text{ ft} - (7.5 \times 10^{-3} \text{ ft/yr} \cdot 6.67 \times 10^4 \text{ yr})}{(2059 \text{ ft/yr})(6.67 \times 10^4 \text{ yr})}$$

$$B = 1.38 \times 10^{-5} \text{ dim}$$

$$L = \frac{3}{7.28 \times 10^{-9} \text{ ft}^{-1}} \left[\left(\frac{2}{3} (7.28 \times 10^{-9} \text{ ft}^{-1} \cdot 7.5 \text{ ft}) + 1.38 \times 10^{-5} \right)^{\frac{1}{2}} - (1.38 \times 10^{-5})^{\frac{1}{2}} \right]$$

$$L = \frac{3}{7.28 \times 10^{-9} \text{ ft}^{-1}} \left(3.7198 \times 10^{-3} - 3.7148 \times 10^{-3} \right)$$

$$L = 2042 \text{ ft}$$

Stoller

Length of Spreading of Leachate 1000 yrs
from corner of disposal cell

JOB NO: N/A

DATE 5-31-07

JOB NAME: MOAB RAP

PREPARED BY: ma

REVIEWED:

DATE: 4-13 13

$$L = \frac{3}{A} \left[\left(\frac{2}{3} A h_0 + B \right)^{\frac{1}{2}} - B^{\frac{1}{2}} \right] \quad \text{from Bear (1979; p 181-183; Equation 5-219)}$$

$$\text{Let } K = 2059 \text{ ft/yr}$$

$$A = \frac{1}{K \sigma'} ; \sigma' = \frac{B'}{K'}$$

where B' = thickness of semipermeous unit (2400 ft)
 K' = hydraulic conductivity of semipermeous unit

$$\sigma' = \frac{2400 \text{ ft}}{0.036 \text{ ft/yr}} = 6.67 \times 10^4 \text{ yr}$$

$$K' = 0.036 \text{ ft/yr}$$

h_0 = head at edge of disposal cell

$$A = \frac{1}{(2059 \text{ ft/yr})(6.67 \times 10^4 \text{ yr})} = 7.28 \times 10^{-9} \text{ ft}^{-1} = A$$

$$\text{Assume } N = 0.01 * (\text{avg. annual pcpr}) = 7.5 \times 10^{-3} \text{ ft/yr} \approx N$$

$$B = \frac{B' - N \sigma'}{K \sigma'} = \frac{2400 \text{ ft} - (7.5 \times 10^{-3} \text{ ft/yr} \cdot 6.67 \times 10^4 \text{ yr})}{(2059 \text{ ft/yr})(6.67 \times 10^4 \text{ yr})}$$

$$B = 1.38 \times 10^{-5} \text{ dim}$$

$$L = \frac{3}{7.28 \times 10^{-9} \text{ ft}^{-1}} \left[\left(\frac{2}{3} (7.28 \times 10^{-9} \text{ ft}^{-1} \cdot 12.3 \text{ ft}) + 1.38 \times 10^{-5} \right)^{\frac{1}{2}} - (1.38 \times 10^{-5})^{\frac{1}{2}} \right]$$

$$L = \frac{3}{7.28 \times 10^{-9} \text{ ft}^{-1}} \left(3.7229 \times 10^{-3} - 3.7148 \times 10^{-3} \right)$$

$$L = 3338 \text{ ft}$$