



# FSEC Energy Research Center

UNIVERSITY OF CENTRAL FLORIDA

## PV-GEMS: Photovoltaic Powered, Grid Assisted Mechanical Solution

FSEC-CR-2116-21

### *Phase 1 Final Report*

December 15, 2021

#### **Submitted to**

Jonathan Cohen

US Department of Energy

#### **Authors**

Eric Martin

Bereket Nigusse

Carlos Colon

Rich Raustad

Danny Parker

Rob Vieira

1679 Clearlake Road

Cocoa, FL 32922-5703

Tel: 321-638-1450 • Fax 321-638-1010

[martin@fsec.ucf.edu](mailto:martin@fsec.ucf.edu)



# Table of Contents

- 1 Project Overview .....3
  - 1.1 Introduction.....3
  - 1.2 Project Objectives.....4
  - 1.3 Phase 1 Progress by Task .....4
  - 1.4 High Level Phase 1 Results and Achievements .....5
- 2 Energy Savings Potential .....5
  - 2.1 Summary of Laboratory Results for Central Florida.....5
  - 2.2 Summary of Simulated Results for Multiple Climates.....7
  - 2.3 Aggregate Technical Potential.....17
- 3 Technical/Engineering Design.....17
- 4 Cost Modeling and Analysis.....19
- Appendix A – Project Tasks and Milestones.....21
- Appendix B – List of Components .....22
- Appendix C – System Installation Photographs .....23
- Appendix D – Building Characteristics .....24
- Appendix E – Simulated Energy Savings by End Use .....32
- Appendix F – Aggregate Technical Potential.....39

# 1 Project Overview

## 1.1 Introduction

The FSEC Energy Research Center (FSEC), a research institute of the University of Central Florida (UCF), designed and evaluated a retrofit solution for existing homes targeting 75% reduction in energy use intensity (EUI) for space conditioning and water heating. The photovoltaic powered, grid enhanced mechanical solution (PV-GEMS) features a grid independent photovoltaic (PV) system designed to partially power a high efficiency minisplit heat pump (MSHP), acting as a supplement to a home's existing central or zonal space conditioning system, and a high efficiency heat pump water heater (HPWH). Alternating current (AC) assisted microinverters sense available power from the PV array, and regulate a steady power source to the space conditioning and water heating components with assistance from the utility grid. No energy generated by the PV array is sent to the utility grid. The PV-GEMS system incorporates a modest battery storage capacity to capture some of the energy generated by the PV array not directly utilized by the components during the day, and make that energy available to the components at night. A schematic of the PV-GEMS system is shown in Figure 1.



Figure 1 PV-GEMS Components

The PV-GEMS system has been designed as an effective retrofit for single family detached/attached homes in general, in every climate except a very cold climate. It is an especially appealing option in cases where achieving significant energy savings through enclosure based, load reduction strategies is not feasible. This includes cases where enclosure retrofits such as wall, window, and roof retrofits are not economical based on energy savings alone, such as in newer homes or in homes in warm climates, as well as cases where enclosure retrofits cannot be performed without structural improvements, such as in older manufactured housing. The team envisions a pre-packaged deployment option that minimizes disruption to occupants and the home by delivering and installing a “pod” that is largely assembled off-site. Figure 2 shows example pods featuring different options for PV array installation.

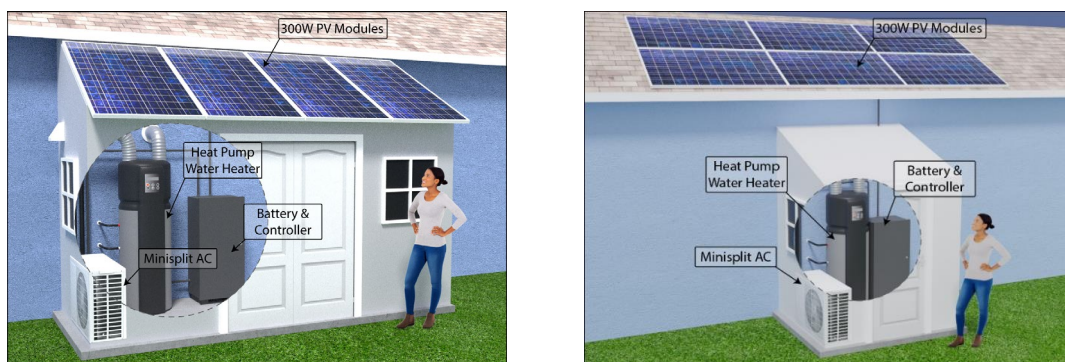

Figure 2. PV-GEMS Concept

PV-GEMS will be most effective when deployed along with economical, low-cost retrofit measures including envelope sealing and duct sealing, which enable control of airflow and pressures, improve comfort, and reduce a home’s thermal loads. With an expected lifetime of 15 years or more, the PV-GEMS system is designed to complement other retrofits that may be incorporated over the longer term including more significant enclosure retrofits and central space conditioning system replacement.

## 1.2 Project Objectives

The primary objectives for Phase 1 were to design and evaluate a PV-GEMS retrofit solution for existing homes targeting 75% reduction in energy use intensity (EUI) for space conditioning and water heating in homes. This included assembling and installing two prototype PV-GEMS systems of differing capacity in full scale, simulated occupancy laboratories, and collecting monitored data. Primary research questions were:

- What EUI reduction for heating, ventilation, air conditioning, and water heating (HVACWH) can be achieved in homes by integrating PV with high efficiency space and water heating equipment operated with their native controls?
- Is there an optimum capacity for the system’s components that balances cost, EUI reduction, and resiliency benefits?

## 1.3 Phase 1 Progress by Task

Progress on major research tasks follows. Appendix A provides a list of all tasks/milestones.

### 1.3.1 Acquire Phase 1 Prototype System Components

Major components acquired for two prototype systems are specified in Table 1. A complete list of components is included in Appendix B. The smaller capacity System A is applicable to most small-to-averaged sized homes. System C (we describe a System B under our simulation section) has larger MSHP, HPWH, PV and battery capacities and is designed for larger homes or small commercial buildings.

**Table 1. Prototype Specifications**

<b>Prototype</b>	<b>PV Array</b>	<b>MSHP</b>	<b>Inverter</b>	<b>HPWH</b>	<b>Storage</b>
System A	1.24 kW (310 W x 4)	12 kBTU	1 each, 1.2 kW	50 gallon	30 AH 48 VDC (2x), 3kWh
System C	2.40 kW (320 W x 8)	16 kBTU	2 each, 1.2 kW	80 gallon	30 AH 48 VDC (4x), 6kWh

### 1.3.2 Assembly and Installation in Laboratories

During Phase 1, the components were integrated to represent prototype PV-GEMS systems and installed and tested in two FSEC laboratories. The 1600 sq. ft. Manufactured Housing (MH) Laboratory represents typical single family housing, and was operated with the smaller System A, and the 2,000 sq. ft. Building Science Laboratory represents small commercial buildings or larger single-family residential construction, and was operated with System C. Photos of laboratories and installed system components are shown in Appendix C.

### 1.3.3 Data Collection and Concept Refinement

Data was collected during summer and fall 2021. The primary purpose for experimentation with System C was to validate and refine PV-GEMS component integration and control functionality. Once PV-GEMS operational features were finalized, they were incorporated into Pilot System A, which was installed in FSEC’s Manufactured Housing (MH) Lab, a 1600 sq. ft., fully furnished,

three-bedroom laboratory home. An initial period of data collection focused on demonstrating functionality of the prototype systems. A second period of data collection focused on documenting performance of the prototype systems. To quantify performance in different buildings in different climates, an EnergyPlus™ simulation was developed and calibrated with monitored data from the prototype systems.

## **1.4 High Level Phase 1 Results and Achievements**

System A PV-GEMS savings over the central Florida cooling season (April – October) were determined based on weather normalized regression techniques using monitored data from the MH Lab. Cooling season savings were determined as no heating data was collected as part of the Phase 1 project. Seasonal savings in grid energy used for cooling and water heating end uses considering the addition of the MSHP and HPWH only averaged 41.7%. Seasonal savings considering the entire set of PV-GEMS system components, inclusive of PV and batteries, averaged 50.1%. These savings are limited due to two factors encountered during Phase 1 testing of off-the-shelf components: 1) Lab systems used a fixed capacity battery charger that resulted in some grid energy being used to charge the battery; 2) Lab systems were only able to discharge stored battery energy at night, and not able to discharge stored battery energy during the day while simultaneously making full use of available energy generated by the PV modules.

To expand on the laboratory results and investigate impacts for PV-GEMS nationally as we envision a final specified product, FSEC simulated the performance of a PV-GEMS retrofit in six U.S. cities representing IECC Climate zones 1-5. *The reduction in EUI for HVACWH end uses from our Energy Plus models showed a range of 50% to 90% across six cities, two house efficiency vintages and three baseline heating types.* Our model included implementing house and duct sealing, and ceiling insulation improvements deployed alongside of PV-GEMS that provided targeted end use savings of 4 to 18 %. *Results from simulation suggest a larger 1.5 ton MSHP capacity optimizes energy savings primarily in colder climates with large heating loads. Simulation results also suggest that the smaller, four module PV system optimizes energy savings and cost in most climates, with increases in utilized solar energy generation only ranging from 16%-41% from doubling PV capacity.*

Using the EERE Exchange Excel tools for building energy savings technical potential calculations, the opportunity national savings are estimated at 3,572 Trillion Btu. For context, equated as a 24/7 generation impact, this would be an average ~120,000 MWe. If half of the dispatched load was electric, this would still comprise more the 100 standard sized power plants.

## **2 Energy Savings Potential**

### **2.1 Summary of Laboratory Results for Central Florida**

During Phase 1, two pilot PV-GEMS systems (Table 1) were installed in highly instrumented laboratory facilities that operated with simulated sensible loads and domestic hot water draws. Pilot System C was installed in FSEC’s Building Science Lab, a 2,000 sqft facility used to represent small commercial buildings and larger single family residential buildings. Data was collected during summer and fall 2021, and the primary purpose for experimentation with System C was to validate and refine PV-GEMS component integration and control functionality. Once PV-GEMS operational features were finalized, they were incorporated into Pilot System A, which was installed in FSEC’s Manufactured Housing (MH) Lab, a 1600 sqft, fully furnished,

three bedroom laboratory home. The existing space conditioning system in this facility enhanced by the PV-GEMS MSHP is a SEER 13 centrally ducted heat pump. Energy use data was collected during the summer and fall of 2021 to evaluate PV-GEMS energy savings potential using weather normalized regression techniques.

The newly collected data from the MH Lab with the PV-GEMS System A operating was compared to historical data from 2019, when the lab was similarly configured and operating in a baseline condition without the PV-GEMS system. The only space conditioning system operating during the baseline condition was the SEER 13 centrally ducted heat pump. The regional standard baseline water heating system that is desired to be utilized to determine PV-GEMS performance is an electric resistance tank, however no baseline water heating energy was available from this facility. Therefore, baseline water heating energy for the same imposed hot water draw profile was estimated by multiplying the monitored HPWH energy consumption by the coefficient of performance (COP) of the HPWH, calculated using monitored energy use, hot water flow, and difference in temperature between incoming mains temperature and outgoing hot water temperature. Calculated COP based on monitored data closely matched the rated COP of the equipment.

Daily total energy used for cooling and water heating was regressed against daily average outdoor temperature to develop models for the lab operating in its baseline condition, and with the addition of the PV-GEMS system. The regressions were intentionally based on outdoor temperature, rather than the difference between indoor and outdoor temperature, due to improved coefficients of determination ( $r^2$ ). Poorer temperature-difference based regressions result from the high efficiency MSHP generating energy savings in part via enabling zoning that results in intentional temperature variations between main and bedroom zones within the home. Figure 3 shows the daily average cooling and water heating energy supplied from the grid vs. the daily average outdoor temperature. Blue data points represent the baseline condition, green data points show less grid energy consumption with the addition of the PV-GEMS MSHP and HPWH, and orange data points show even less grid energy consumption when PV-GEMS PV, inverter, and battery components are considered along with the efficiency of the MSHP and HPWH.  $R^2$  values are shown for both linear and polynomial fits of each data series.

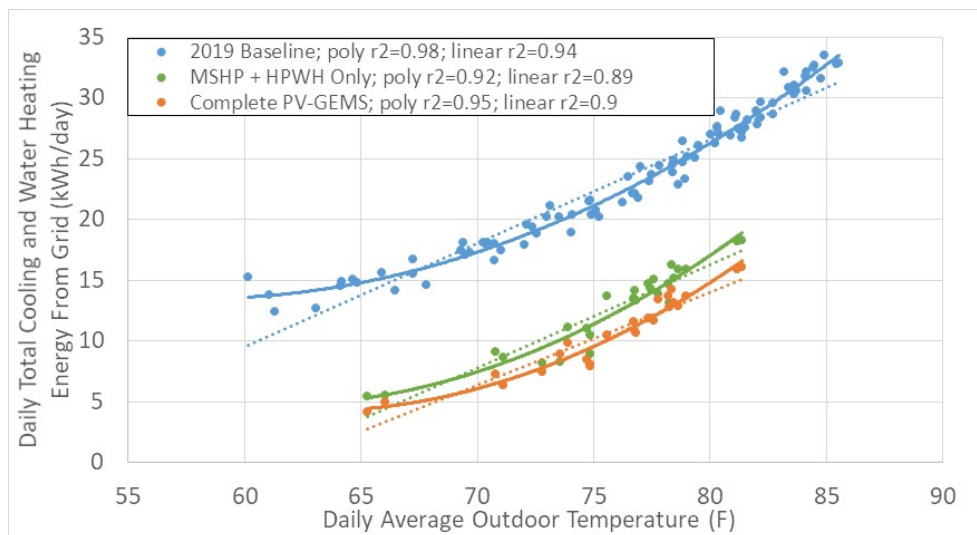

**Figure 3. MH Lab monitored, daily total grid energy utilized for space cooling and water heating with and without PV-GEMS System A components.**



PV-GEMS savings over the central Florida cooling season (April – October) were calculated utilizing monitored weather data from the lab. Cooling season savings were determined as no heating data was collected as part of the Phase 1 project. Seasonal savings in grid energy used for HVACWH end uses considering the addition of the MSHP and HPWH only averaged 38.5% and 41.7% for the linear and polynomial regressions respectively. Seasonal savings considering the entire set of PV-GEMS system components, inclusive of PV and batteries, averaged 47.8% and 50.1% for the linear and polynomial regressions respectively.

These monitored savings obtained during Phase 1 do not include any added efficiency envisioned to be obtained by deployment of shallow, cost effective retrofits alongside of PV-GEMS. These savings are further limited due to two factors encountered during Phase 1 laboratory testing: 1) Phase 1 systems used a fixed capacity battery charger that resulted in some grid energy being used to charge the battery; and 2) Phase 1 systems were only able to discharge stored battery energy at night, and not able to discharge stored battery energy during the day while simultaneously making full use of available energy generated by the PV modules. Activities to overcome these limitations have been proposed as part of Phase 2.

## **2.2 Summary of Simulated Results for Multiple Climates**

### **2.2.1 Development of Regional Prototypes for Simulation Analysis**

As the PV-GEMS concept targets applications in moderate climates, we created regional prototypes for simulation analysis representing existing single family homes in five climate zones of increasing winter severity. We used the NREL ResStock tool to establish the typical characteristics of these homes across climates. ResStock<sup>1</sup> uses census, EIA survey and regional homebuilder data sources to establish relevant characteristics that will likely impact energy consumption. We evaluated the characteristics associated both with the most typical housing size and configuration as well as the factors that appeared to be associated with reported differences in housing configuration. We undertook an analysis in each climate to determine detailed characteristics for each simulated building designed to represent the housing stock in each region, and investigated potential for low cost, non-disruptive enclosure and duct system retrofits that could be deployed alongside of PV-GEMS. Details are shown in Appendix D.

*Segmentation of Buildings by Heating System Type* - We found that at many locations there were a variety of space heating systems in typical use. We found that in all but climate zone 1 (Miami), we should evaluate PV-GEMS operating against gas furnaces, electric resistance furnaces and air source heat pumps. In climate zone 1, with almost next to no heating, we discovered the ResStock data suggested heat pumps were uncommon and could be neglected.

*Segmentation of Buildings by Vintage* - We found that the insulation, tightness and window characteristics of greatest interest to the simulation results were most correlated to the age of the building. Evaluating by decades in the data base we found the greatest differences created in two large groups were for buildings built since 1990 and those previous. These two groups were used for all locations to create two prototype buildings with the most typical characteristics. These building prototypes were the 1989 and earlier (80s) prototype and the 1990 and later (90s) prototype. For the natural gas furnace prototype, the water heater was assumed to follow the space heating system fuel choice according to the ResStock analysis.

---

<sup>1</sup> ResStock, <https://www.nrel.gov/buildings/resstock.html>

## 2.2.2 EnergyPlus Simulation

An EnergyPlus Simulation as developed that configured the PV-GEMS system generally the same as for the laboratory evaluation as described in sections 2.1 and 3.0 of this report. The simulations added enhancements to overcome limitations identified during laboratory testing as previously stated, anticipating these limitations would be easily overcome in the eventual commercialized product. manufactured for an eventual product.

EnergyPlus Version 9.5<sup>2</sup>, DOE’s whole building performance simulation program was used to predict the annual energy savings potential of PV-GEMS packaged technology solutions. For the analysis, single family house prototype models representing six U.S. climate zones and two vintages were created using ResStock<sup>3</sup>. There are two or three baseline models for each of the six site locations depending on the central HVAC system types. Each baseline model has an “improved” house model created by adding envelope sealing, duct sealing, and ceiling insulation retrofits. Each of the PV-GEMS prototype houses adds a packaged technology solution to the improved cases consisting of a variable speed MSHP running as the first priority with the existing baseline central system as a secondary system, a HPWH, a Photovoltaic Generator (PVWatts), a DC-to-AC Inverter, and electric storage battery/charger. EnergyPlus simulation was performed for the baseline, improved, and PV-GEMS prototype house models.

*Baseline Models* - The baseline buildings are single family detached houses that have ducted electric resistance furnace, natural gas furnace, or air-to-air heat pump with supplemental electric heating coil, and a storage electric resistance or natural gas water heater. The prototype houses have 1778 sqft conditioned floor area. House characteristics of the prototype model simulated for six U.S. geographic locations are provided in Table 2.

**Table 2. Simulated single family detached houses characteristics**

Site Location	Foundation Type	Construction Type	Climate Zones (ASHRAE 169-2006)
Miami, FL	Slab on Grade	CMU	1A
Phoenix, AR	Slab on Grade	CMU	2B
Atlanta, GE	Slab on Grade	Wood Frame	3A
Baltimore, MD	Basement, unheated	Wood Frame	4A
Portland, OR	Crawlspace	Wood Frame	4C
Durango, Colorado	Basement, unheated	Wood Frame	5B

All cities except Miami have prototype buildings with Electric Resistance Furnace (ER), Gas Furnace (Gas) and Heat Pump (HP) system types determined to be to representative of the housing stock. In Miami, HP is not prevalent and hence not included in the analysis. The baseline and improved use the space heating matching fuel storage water heating systems.

*Improved Models* - Within the analysis, we created an “improved” or “shallow retrofit” building upon which to install the PV-GEMS system. This was done by taking the building baseline characteristics and then improving them for both the 80s and 90s vintage. Only very low cost options were considered. Building air tightness was improved, but not improved below 6 ACH @50Pa test pressure so that mechanical ventilation would not be needed. Although the direct savings of LED lighting replacement was not taken credit for in this project’s energy savings evaluation, the large interaction with cooling energy demand was evaluated. Baseline ceiling insulation varied with location. The typical shallow retrofit options are listed in Table 3.

<sup>2</sup> <https://github.com/NREL/EnergyPlus/releases/tag/v9.5.0>



**Table 3. Typical Evaluated Shallow Retrofit Measures for PV-GEMS Analysis**

Characteristic	80s Baseline	80s Improved	90s Baseline	90s Improved
Ceiling Insulation (R)	19	38	30	30
Air Tightness (50Pa Pressure)	10	6	8	6
Duct Leakage (%)	15	10	10	5
LED lighting Percentage (%)	20	80	20	80

See Appendix D for details of the baseline and improved prototype buildings simulated.

*PV-GEMS Prototype Models* - The simulated PV-GEMS system represents a packaged technology solution *added to each of the improved prototype house models*. The packaged technology solution includes MSHP, HPWH, PV-Generator, Inverter and storage battery. Specifications of the packaged PV-GEMS technology solutions used in the simulation are provided in Table 4. System A is very close to the smaller system in the FSEC MH Laboratory. System B increases the size of the MSHP to 1.5 tons. System C is similar to the larger system in the FSEC Building Science Laboratory but differs in water heating (simulation of 60 gallons vs. lab of 80 gallons) and battery capacity (simulation of 3 kWh vs. lab 6kWh).

**Table 4. PV-GEMS Product Specification used in the simulation.**

Products	Product Specification – System A
MSHP	SEER 29 (Btu/W-h), and HSPF 14 (Btu/W-h), Capacity 1 ton
HPWH	60 Gal, Rated COP 3.0, Heating Capacity 5000.0 W (17,060 Btu/hr)
PV - Panels	4 Panels, 310 W each, Fixed Mount @ Local Latitude Angle facing south, no shade
Inverter	1.24 kW Electric Power Max Output, DC-AC Converter Eff = 0.84 – 0.93
Storage Battery	3 kWh (2 Battery each 1.5 kWh), Charging and Discharging Eff = 90%
Product Specification – System B	
MSHP	SEER 29 (Btu/W-h), and HSPF 14 (Btu/W-h), Capacity 1.5 ton
HPWH	60 Gal, Rated COP 3.0, Heating Capacity 5000.0 W
PV - Panels	4 Panels, 310 W each, Fixed Mount @ Local Latitude Angle
Inverter	2.48 kW Electric Power Max Output, DC-AC Converter Eff = 0.84 – 0.93
Storage Battery	3 kWh (2 Battery each 1.5 kWh), Charging and Discharging Eff = 90%
Product Specification – System C	
MSHP	SEER 29 (Btu/W-h), and HSPF 14 (Btu/W-h), Capacity 1.5 ton
HPWH	60 Gal, Rated COP 3.0, Heating Capacity 5000.0 W
PV - Panels	8 Panels, 310 W each, Fixed Mount @ Local Latitude Angle
Inverter	2.48 kW Electric Power Max Output, DC-AC Converter Eff = 0.84 – 0.93
Storage Battery	3 kWh (2 Battery each 1.5 kWh), Charging and Discharging Eff = 90%

In EnergyPlus the MSHP was represented by a variable speed air-to-air heat pump, object ZoneHVAC:PackagedTerminalHeatPump. The MSHP and the central system were integrated to operate sequentially with MSHP as the first priority and the central system as the second priority. For Miami, Phoenix and Atlanta, the cooling and heating load were split between MSHP and the central system at 75%/25% level, respectively, which ensures the central system runs enough to maintain bedroom comfort, especially at night. The load split assumption was determined based on previous field and simulation research conducted in Florida by FSEC<sup>3,4</sup>. We did not have previous research data for cold climates. Thus, for Baltimore, Durango and Portland, the MSHP

<sup>3</sup> Sutherland, K., D. Parker, and E. Martin. 2016. “Evaluation of Minisplit Heat Pumps as Supplemental and Full System Retrofits in a Hot Humid Climate.” *Proceedings of the 2016 Summer Study on Energy Efficiency in Buildings*, ACEEE, Washington D.C. <https://www.fsec.ucf.edu/en/publications/pdf/fsec-rr-646-16.pdf>

<sup>4</sup> Metzger et al., *Who’s Leading: The Dance between MSHP and Existing HVAC Systems*. 2020 ACEEE Summer Study on Energy Efficiency in Buildings. Date Published. 8-17-2020

was enabled to cool and heat as much load as it could. If the load exceeds the available MSHP capacity, the central system handles the remainder. The HPWH was modeled using EnergyPlus object “WaterHeater:HeatPump:PumpedCondenser”. This object has a packaged air-source electric HPWH and a 60-gallon hot water storage tank with integral supplemental electric resistance heating element. The air-source electric HPWH replaces electric resistance or natural gas domestic water heating system in the baseline building models.

The PV modules were represented by “Generator: PVWatts” EnergyPlus object and contains four or eight PV panels with 310 W rated DC power output. The PV modules were fixed mount. The PV generator rated output was 1.24 kW or 2.48 kW. The electric storage battery was represented with EnergyPlus object ElectricLoadCenter:Storage:Simple object. The storage capacity of 3.0 kWh, and charging and discharging efficiencies of 90%. The DC-AC inverter was represented by ElectricLoadCenter:Inverter:LookUpTable. The inverter rated maximum AC power output was 1.25 kW or 2.50 kW, has ancillary electric power use of 6W, and DC-AC power conversion efficiency range of 0.84 to 0.93 depending on the power output.

Generator and Battery Operation Control - In EnergyPlus, electric generator, DC-AC inverters and electric storage battery operations were managed by “ElectricLoadCenter:Distribution” object. The electric battery storage operation scheme selected for this application was “TrackMeterDemandStoreExcessOnSite”. This operating mode tracks a meter demand on the MSHP, HPWH and inverter ancillary power and tries to meet the tracked meter demand using electric energy generated by PV system. Any excess energy generated is supplied to the electric storage battery. The electric storage battery via the electric load center provides electric power to the tracked load when there is no PV power output. When the battery is fully charged and the tracked meter demand is met, then the excess power generated is reported as unused surplus. An electric load center schematic shown in Figure 7 tracks a meter demand and electric storage battery dispatch control.

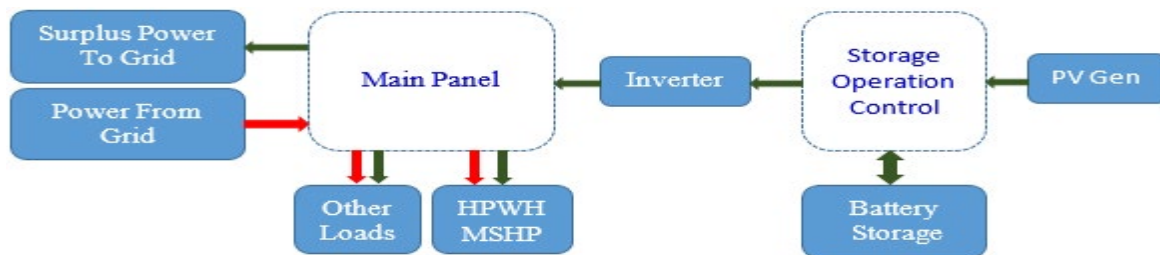

**Figure 4. Electric Load Center with EnergyPlus *TrackMeterDemandStoreExcessOnSite* Operating Mode**

Energy Savings Calculation and Simulation Results - Energy savings potential of the Improved and PV-GEMS prototype buildings were determined relative to the baseline buildings. The PV-GEMS energy savings include space heating and cooling energy, water heating energy and net PV-generated energy and utilized by the tracked load (PV-GEMS). The tracked meter includes MSHP, HPWH, and the inverter parasitic load. Any excess PV-generated energy not used by the tracked load is not included in the energy savings potential.

PV-GEMS Performance in Atlanta, Georgia - Figure 5 shows the annual energy by end-use for the electric furnace central system baseline house, the same house with the shallow retrofits (“improved”) and that improved house with the PV-GEMS. Total from grid for HVACWH is reduced to just 5343 kWh annually representing a savings of 69.4%. Details of reduction of end uses for each system for each climate are given in Appendix E.

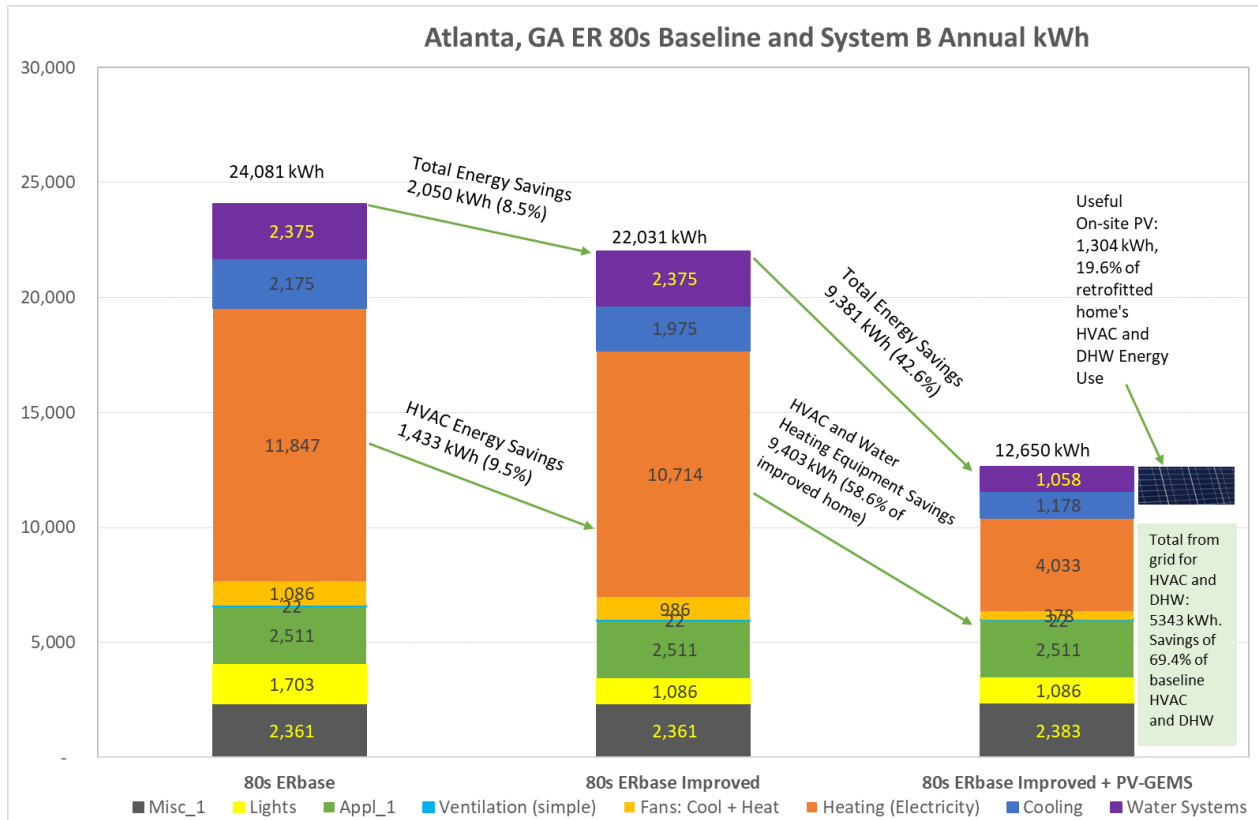

**Figure 5. Energy end use for baseline home, home with shallow retrofit improvements and with full PV-GEMS for system B (1.5 ton MSHP with 60- gallon HPWH and 1.24 KW PV system) for Atlanta**

The annual tracked electric load of the PV-GEMS System B MSHP and HPWH for Atlanta 80s vintage homes was 3061 kWh (10,444 kBtu, or 5.87 kBtu/ft<sup>2</sup>). On-site generated energy for system B was 1679 kWh (5727 kBtu, or 3.22 kBtu/ft<sup>2</sup>), and the PV-GEMS system was only able to utilize 1,304 kWh (2.50 kBtu/ft<sup>2</sup>), or 78.0%. The remaining site generated energy (0.72 kBtu/ft<sup>2</sup>) could not be utilized by PV-GEMS due to load and energy generation time mismatch.

Table 5 summarizes the baseline energy utilization intensity (EUI), and the energy savings potential for HVACWH of the improved and the three PV-GEMS technology solution types for Atlanta, Georgia. The annual site EUI of the 80s vintage electric furnace central system baseline prototype housing was 33.6 kBtu/ft<sup>2</sup>, the savings potential for the Improved was 2.8 kBtu/ft<sup>2</sup> (8.2%), and the PV-GEMS energy savings potential for systems A, B and C were 21.6 kBtu/ft<sup>2</sup> (64.3%), 23.3 kBtu/ft<sup>2</sup> (69.4%), and 23.9 kBtu/ft<sup>2</sup> (71.3%), respectively. The on-site PV generator net contribution to the energy savings potential for 80s vintage and central electric furnace system prototype house was 2.49 kBtu/ft<sup>2</sup>. The energy savings potential for Atlanta, Georgia across the two house vintages, central HVAC systems investigated and the three PV-GEMS configurations range 8.6 – 32.4 kBtu/ft<sup>2</sup> and the on-site PV generator contributions to energy savings potential range was 2.13 – 3.16 kBtu/ft<sup>2</sup>.

Figure 6 shows the Improved and PV-GEMS percent energy savings potential in HVACWH relative to the baseline for Atlanta, Georgia for each of the six baselines. The energy savings potential of the PV-GEMS technology solutions for Atlanta ranges from 60.7% to 78.7%. The baseline prototype buildings EUIs are included in the diagram.

**Table 5. Baseline HVACWH Site EUI and Energy Savings Potential for Atlanta**

	80s			90s		
	ER	Gas	HP	ER	Gas	HP
Baseline: EUI, kBtu/ft <sup>2</sup>	33.6	44.0	19.2	17.9	24.7	12.1
Improved: Savings, EUI, kBtu/ft <sup>2</sup> (%)	2.8 (8.2)	4.1 (9.3)	1.4 (7.5)	1.2 (6.9)	1.8 (7.5)	0.7 (5.5)
PV-GEMS: 1Ton MSHP 4 PV Panels, Savings, EUI, kBtu/ft <sup>2</sup> , (%)	21.6 (64.3)	29.5 (67.0)	11.6 (60.7)	13.1 (73.0)	18.9 (76.6)	8.6 (70.9)
PV-GEMS: 1.5Ton MSHP 4 PV Panels, Savings, EUI, kBtu/ft <sup>2</sup> , (%)	23.3 (69.4)	31.8 (72.3)	12.4 (64.6)	13.2 (73.5)	19.1 (77.3)	8.6 (71.3)
PV-GEMS: 1.5Ton MSHP 8 PV Panels, Savings, EUI, kBtu/ft <sup>2</sup> , (%)	23.9 (71.3)	32.4 (73.7)	13.0 (67.9)	13.5 (75.4)	19.4 (78.7)	9.0 (74.0)

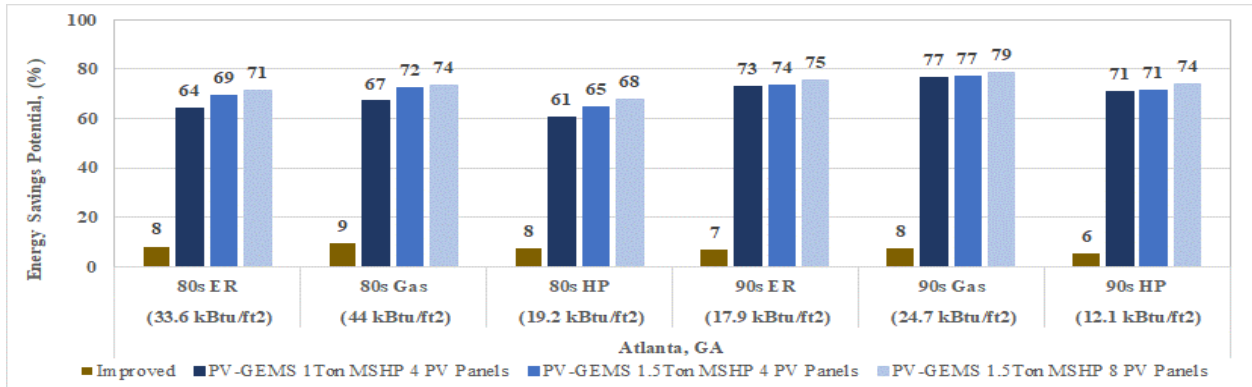

**Figure 6 Improved and PV-GEMS Scenarios Energy Savings Potential in Percent for Atlanta**

*PV-GEMS Performance in Baltimore, Maryland* - Table 6 summarizes the baseline energy utilization intensity (EUI), and the energy savings potential of the improved and the three PV-GEMS packaged technology solutions for Baltimore, Maryland. The EUI savings potential for Baltimore range 10.3 – 51.0 kBtu/ft<sup>2</sup> depending on the house vintage and the central HVAC system type. Figure 7 shows the PV-GEMS technology solutions percent energy savings potential relative to the baseline for Baltimore, Maryland. The PV-GEMS packaged solution energy savings potential of 85.2% for gas furnace HVAC system type and 90s house vintage was predicted.

**Table 6. Baseline HVACWH EUI and Energy Savings Potential for Baltimore**

	80s			90s		
	ER	Gas	HP	ER	Gas	HP
Baseline: EUI, kBtu/ft <sup>2</sup>	53.6	71.1	27.8	27.6	38.2	16.1
Improved: Savings, EUI, kBtu/ft <sup>2</sup> (%)	7.8 (14.6)	7.7 (10.8)	3.6 (12.9)	2.9 (10.4)	2.7 (7.0)	0.9 (5.4)
PV-GEMS: 1Ton MSHP 4 PV Panels, Savings, EUI, kBtu/ft <sup>2</sup> , (%)	32.1 (59.9)	42.5 (59.8)	14.8 (53.4)	20.6 (74.8)	29.0 (75.9)	10.3 (64.1)
PV-GEMS: 1.5Ton MSHP 4 PV Panels, Savings, EUI, kBtu/ft <sup>2</sup> , (%)	37.5 (69.8)	50.0 (70.3)	16.7 (60.0)	22.4 (81.0)	31.8 (83.3)	11.0 (68.4)
PV-GEMS: 1.5Ton MSHP 8 PV Panels, Savings, EUI, kBtu/ft <sup>2</sup> , (%)	38.5 (71.8)	51.0 (71.8)	17.7 (63.8)	23.0 (83.4)	32.5 (85.2)	11.7 (72.7)

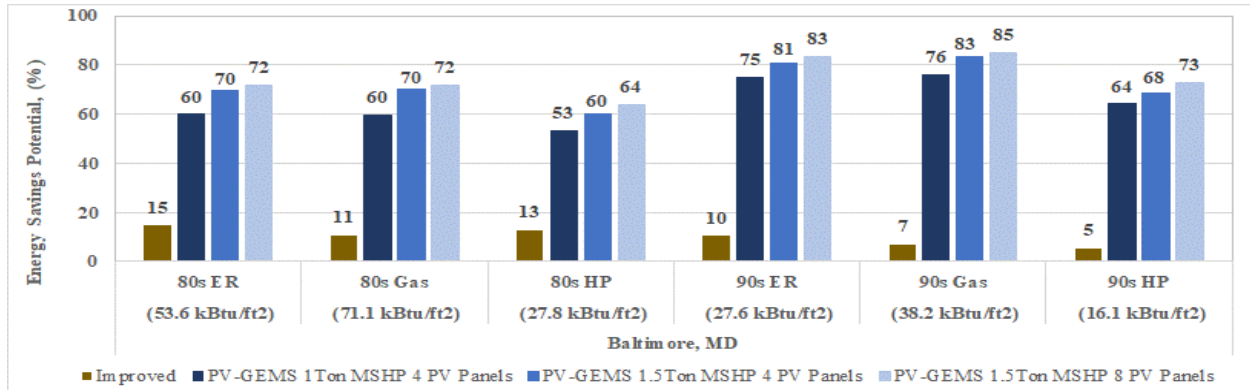

Figure 7 Improved and PV-GEMS Scenarios Energy Savings Potential in Percent for Baltimore

*PV-GEMS Performance in Miami, Florida* - Table 7 summarizes the baseline EUI, and the EUI and percent energy savings for improved and the PV-GEMS for Miami, Florida for the two housing vintages and three HVAC system types. The PV-GEMS EUI savings potential range 11.2 – 14.9 kBtu/ft<sup>2</sup> depending on the PV-GEMS technology solution and the central HVAC system type. Heat Pump is not prevalent in the Miami area housing stock due to insignificant space heating load; hence it is not included in the EnergyPlus simulation analysis. Figure 8 shows percent energy savings potentials of the improved house and the three PV-GEMS technology solutions for Miami, Florida. The percent savings potential across the two house vintages and the two central HVAC system types simulated range from 72.0% to 80.3%.

Table 7. Baseline HVACWH EUI and Energy Savings Potential for Miami

	80s			90s		
	ER	Gas	HP	ER	Gas	HP
Baseline: EUI, kBtu/ft <sup>2</sup>	15.5	18.6	-	12.9	15.8	-
Improved: Savings, EUI, kBtu/ft <sup>2</sup> (%)	1.6 (10.5)	1.8 (9.9)	-	0.8 (6.5)	0.9 (6.0)	-
PV-GEMS: 1Ton MSHP 4 PV Panels, Savings, EUI, kBtu/ft <sup>2</sup> , (%)	11.2 (72.0)	14.0 (75.5)	-	9.5 (73.5)	12.2 (77.4)	-
PV-GEMS: 1.5Ton MSHP 4 PV Panels, Savings, EUI, kBtu/ft <sup>2</sup> , (%)	11.4 (73.2)	14.3 (76.7)	-	9.5 (73.6)	12.2 (77.5)	-
PV-GEMS: 1.5Ton MSHP 8 PV Panels, Savings, EUI, kBtu/ft <sup>2</sup> , (%)	12.0 (77.1)	14.9 (80.2)	-	9.9 (76.8)	12.7 (80.3)	-

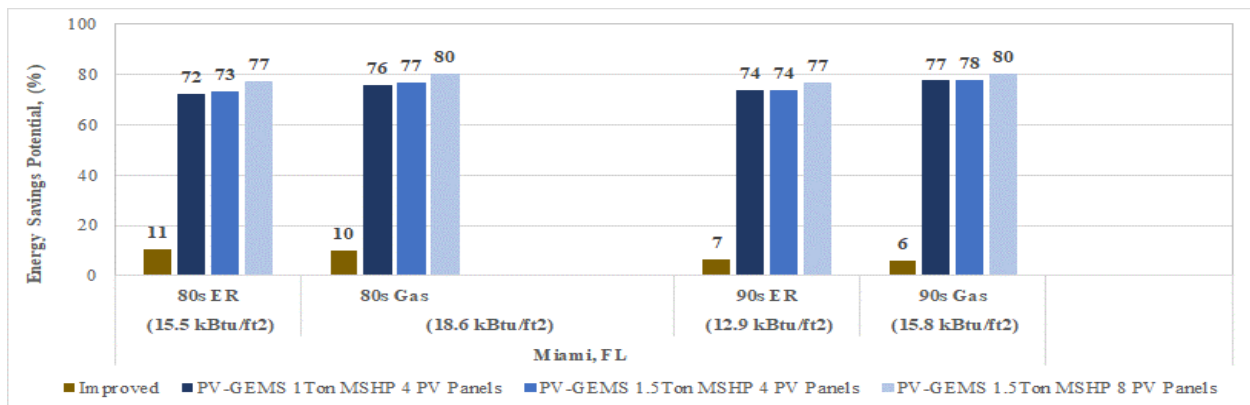

Figure 8 Improved and PV-GEMS Scenarios Energy Savings Potential in Percent for Miami



*PV-GEMS Performance in Phoenix, Arizona* - Table 8 summarizes the baseline EUI and the EUI savings potential of the improved and PV-GEMS technology solutions for Phoenix, Arizona. The annual site EUI savings potential for Phoenix across the two house vintages, the three central HVAC systems types and the three PV-GMES technology solution configurations range 10.5 – 20.7 kBtu/ft<sup>2</sup>. Figure 9 shows percent site energy savings of the improved and the PV-GEMS technology solutions for Phoenix, Arizona. The percent energy savings potential across the two house vintages, the three central HVAC system types and the three PV-GEMS packaged technology solutions configuration simulated range from 58.7% to 76.1%.

**Table 8. Baseline HVACWH EUI and Energy Savings Potential for Phoenix**

	80s			90s		
	ER	Gas	HP	ER	Gas	HP
Baseline: EUI, kBtu/ft <sup>2</sup>	24.7	28.5	22.5	16.9	20.0	16.1
Improved: Savings, EUI, kBtu/ft <sup>2</sup> (%)	3.1 (12.6)	3.6 (12.6)	2.6 (11.7)	1.2 (7.3)	1.4 (7.0)	1.1 (6.9)
PV-GEMS: 1Ton MSHP 4 PV Panels, Savings, EUI, kBtu/ft <sup>2</sup> , (%)	14.9 (60.5)	18.3 (64.3)	13.2 (58.7)	11.1 (66.0)	14.0 (69.8)	10.5 (65.3)
PV-GEMS: 1.5Ton MSHP 4 PV Panels, Savings, EUI, kBtu/ft <sup>2</sup> , (%)	16.4 (66.3)	19.8 (69.4)	14.6 (64.8)	11.8 (69.7)	14.7 (73.2)	11.1 (69.0)
PV-GEMS: 1.5Ton MSHP 8 PV Panels, Savings, EUI, kBtu/ft <sup>2</sup> , (%)	17.3 (70.0)	20.7 (72.6)	15.5 (68.8)	12.3 (72.9)	15.2 (76.1)	11.7 (72.4)

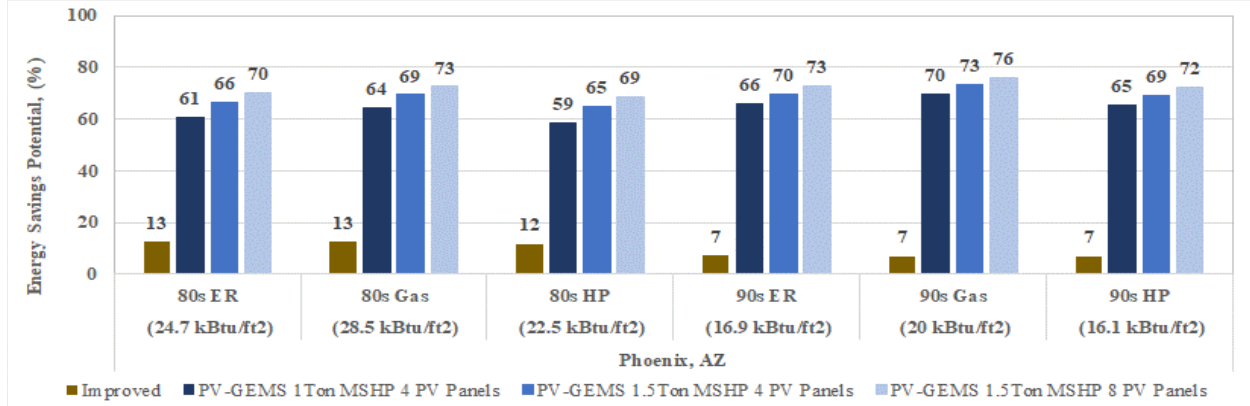

**Figure 9 Improved and PV-GEMS Scenarios Energy Savings Potential in Percent for Phoenix**

*PV-GEMS Performance in Portland, Oregon* - Table 9 summarizes the baseline EUI, and the energy savings potential of the improved and PV-GEMS packaged technology solutions for

**Table 9. Baseline HVACWH EUI and Energy Savings Potential for Portland**

	80s			90s		
	ER	Gas	HP	ER	Gas	HP
Baseline: EUI, kBtu/ft <sup>2</sup>	57.7	76.6	26.0	26.1	36.8	13.9
Improved: Savings, EUI, kBtu/ft <sup>2</sup> (%)	8.4 (14.6)	12.0 (15.7)	3.1 (11.8)	2.0 (7.6)	3.4 (9.1)	0.5 (3.9)
PV-GEMS: 1Ton MSHP 4 PV Panels, Savings, EUI, kBtu/ft <sup>2</sup> , (%)	41.1 (71.3)	55.9 (73.0)	15.5 (59.6)	21.6 (82.7)	31.5 (85.6)	9.7 (69.6)
PV-GEMS: 1.5Ton MSHP 4 PV Panels, Savings, EUI, kBtu/ft <sup>2</sup> , (%)	46.7 (81.0)	63.6 (83.0)	17.2 (66.3)	22.1 (84.6)	32.5 (88.3)	9.9 (71.3)
PV-GEMS: 1.5Ton MSHP 8 PV Panels, Savings, EUI, kBtu/ft <sup>2</sup> , (%)	47.6 (82.5)	64.4 (84.2)	18.1 (69.6)	22.6 (86.9)	33.1 (89.9)	10.5 (75.5)



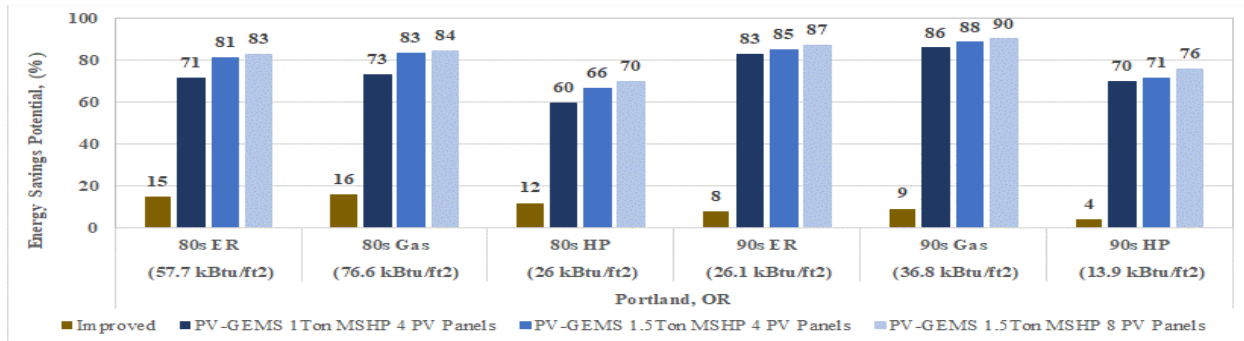

**Figure 10 Improved and PV-GEMS Scenarios Energy Savings Potential in Percent for Portland**

Portland, Oregon. The annual site EUI savings potential for Portland ranges from 9.7 to 64.4 kBtu/ft<sup>2</sup>. Figure 10 shows percent energy savings potential of the improved prototype buildings and PV-GEMS packaged technology solutions for Portland, Oregon. The percent site energy savings potential across the two house vintages, the three central HVAC system types and the three PV-GEMS packaged technology solutions configuration range from 59.6% to 89.9%.

*PV-GEMS Performance in Durango, Colorado* - Table 10 summarizes the baseline EUI, and the energy savings potential of the improved and PV-GEMS packaged technology solutions for Durango, Colorado. The annual site EUI savings potential for Durango ranges from 11.6 to 58.6 kBtu/ft<sup>2</sup>. Figure 11 shows percent energy savings potential of the improved prototype buildings and PV-GEMS packaged technology solutions for Durango, Colorado. The percent site energy savings potential across the two house vintages, the three central HVAC system types and the three PV-GEMS packaged technology solutions range from 49.8% to 78.9%.

**Table 10. Baseline HVACWH EUI and Energy Savings Potential for Durango**

	80s			90s		
	ER	Gas	HP	ER	Gas	HP
Baseline: EUI, kBtu/ft <sup>2</sup>	70.8	93.4	40.9	36.7	50.4	21.3
Improved: Savings, EUI, kBtu/ft <sup>2</sup> (%)	12 (16.9)	10.2 (10.9)	7.4 (18.0)	4.3 (11.8)	3.4 (6.7)	1.3 (5.9)
PV-GEMS: 1Ton MSHP 4 PV Panels, Savings, EUI, kBtu/ft <sup>2</sup> , (%)	37.6 (53.1)	47.9 (51.3)	20.4 (49.8)	24.5 (66.7)	33.6 (66.7)	11.6 (54.4)
PV-GEMS: 1.5Ton MSHP 4 PV Panels, Savings, EUI, kBtu/ft <sup>2</sup> , (%)	44.4 (62.7)	57.5 (61.5)	23.0 (56.2)	27.8 (75.7)	38.8 (77.1)	13.0 (61.0)
PV-GEMS: 1.5Ton MSHP 8 PV Panels, Savings, EUI, kBtu/ft <sup>2</sup> , (%)	45.5 (64.3)	58.6 (62.8)	24.1 (59.0)	28.7 (78.0)	39.7 (78.9)	13.9 (65.2)

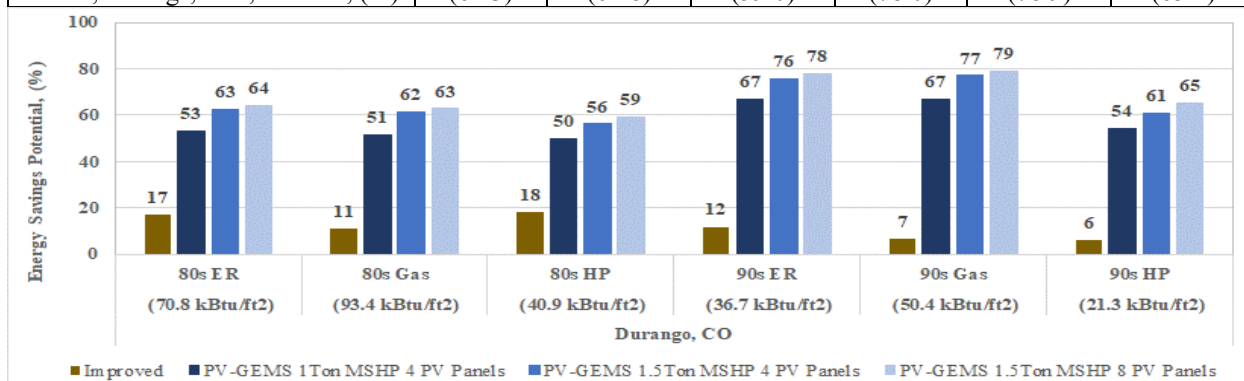

**Figure 11 Improved and PV-GEMS Scenarios Energy Savings Potential in Percent for Durango**

### 2.2.3 Simulation Results Summary

There are a number of observations made from the 150 simulations:

1. There is an opportunity for large percentage savings in all climates, building stock features and heating systems. In each of the six cities, at least one combination of PV-GEMS system type, baseline heating type and building stock resulted in a potential savings of 75% of heating, cooling and water heating energy use. The highest percent energy savings potential of 90% was predicted in Portland for 90s+ vintage gas furnace central HVAC system type.
2. It is more difficult to achieve high *percentage* savings in older homes in cold climates because walls and windows are poor. Older homes represented in the model, frequently have no wall insulation, and envelope efficiency improvements modeled do not improve walls and windows. However, *the highest site EUI savings* potential of 64.4 kBtu/ft<sup>2</sup> was predicted in Portland for the pre 1989 vintage gas furnace central HVAC system type. The lowest EUI savings potential of 9.5 kBtu/ft<sup>2</sup> was predicted in Miami for 90s vintage home.
3. Larger MSHP systems, as modeled, were more beneficial in colder climates. The difference between System A with a 1-ton supplemental MSHP and system B, with a 1.5-ton supplemental MSHP is largest in cold climates. Part of this is due to modeling the warmer climates with a maximum contribution of 75% for the supplemental MSHP heat pump whereas that limitation was not applied to Baltimore, Durango or Portland.
4. The baseline heat pump heating system homes showed smaller heating energy savings with PV-GEMS. Low efficiency of gas furnace (AFUE 80%) and electric furnace (COP=1) in the baseline model favors higher energy savings when PV-GEMS is added.
5. The annual on-site PV-generated net energy utilization by the PV-GEMS ranges from 1.75 kBtu/ft<sup>2</sup> for the 1.24 kW, four module PV-array in Portland, Oregon to 4.35 kBtu/ft<sup>2</sup> for the 2.48 kW, eight module PV-array in Durango, Colorado.
6. For cases where the PV-array was doubled from four to eight modules without changing the tracked electric load and the battery storage capacity, that change resulted in an increase of on-site PV-generated net energy utilization by about 16% – 42% depending on location.

Table 11 and Figure 12 summarizes the minimum and maximum percent site energy savings potential across the three PV-GEMS solutions and two prototype house vintages by city.

**Table 11. PV-GEMS Technology Solutions Energy Saving Potential by city**

City	Minimum	Maximum
	% (kBtu/ft <sup>2</sup> )	% (kBtu/ft <sup>2</sup> )
Atlanta, GA*	60.7 (11.6)	78.7 (19.4)
Baltimore, MD	52.4 (14.5)	85.2 (32.5)
Miami, FL*	72.0 (11.2)	80.3 (12.7)
Phoenix, AZ*	58.7 (13.2)	76.1 (15.2)
Portland, OR	59.6 (15.5)	89.9 (33.1)
Durango, CO	49.8 (20.4)	78.9 (39.7)

\* Modeled with maximum contribution from MSHP as 75% for each time step simulated.

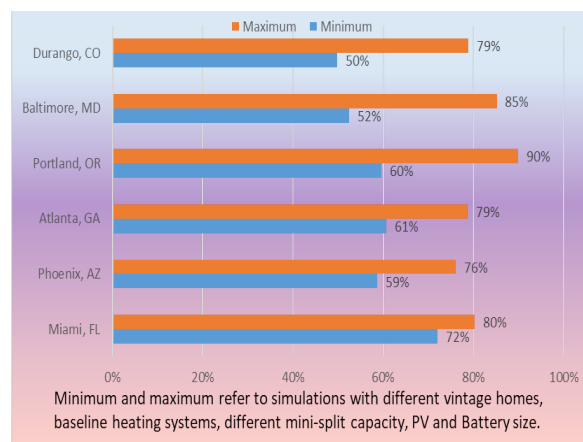

**Figure 12. Percentage Reduction of Combined Heating, Cooling and Water Heating**

### 2.3 Aggregate Technical Potential

The energy savings reported by the EnergyPlus simulations across various climate zones were used to estimate the technical potential of the PV-GEMS concept. The energy savings reported for each climate zone were summed to provide the national potential. National savings are estimated at 3,572 Trillion Btu, with additional detail shown in Appendix F.

## 3 Technical/Engineering Design

The PV-GEMS systems used for our laboratory research integrate high-efficiency HVACWH equipment connected to off-grid single phase 240VAC hybrid microinverters. Each hybrid inverter features four independent DC input ports which accept power from photovoltaic modules or from energy storage (LiFePO4 batteries). Battery charging is accomplished using a dedicated charger (240VAC, 700W) acting as a daytime load during peak sun hours in addition to the MSHP and HPWH loads. A summary of PV-GEMS components utilized for system A and C are shown in Table 12.

**Table 12. Summary of PV-GEMS pilot systems components**

PV-GEMS	PV Module Model	Module efficiency	# PV Modules	Array Size (kW <sub>pk</sub> )	Aperture Area (m <sup>2</sup> )	Off-grid Micro Inverter (kW <sub>pk</sub> )	Storage (kWh)
Pilot System A	CS6x-310P	16.16%	4	2.56	7.675	1.25	3.04
Pilot System C	CS1H 320	18.98%	8	1.24	13.491	2.5	6.08

Off-grid microinverters assisted by solar PV modules reduce the power consumption from the grid according to real-time daytime solar resources available. Although the peak power of a single inverter is stated as 1.25 kW (Table 13), a pair of CIM-1200Ya inverters in master-slave configuration supply up to 4.5kW, where the grid supplied the difference above rated wattage.

**Table 13. Specifications of a single four DC ports Cybo off-grid microinverter**

Inverter Single Phase 60 Hz	Output/Unit	AC Output (W)	Port Operating DC Voltage	Input power (watts/DC port)	Peak Efficiency
CIM-1200Ya	240 VAC (204-264VAC) 4A RMS	960W (rated) 1250W (Peak)	17-58 VDC (solar) 47-58VDC (battery)	250-380w 330W (max)	96%

Figure 13 provides a schematic of the PV-GEMS system consisting of a 240VAC hybrid microinverter and appliance loads (i.e., MSHP, HPWH and battery charger). The AC connected hybrid inverter features four DC input ports per unit. A 20A breaker provides 240VAC grid connection to the off-grid inverter. PV modules and battery are connected via individual DC input ports. Battery power was integrated by utilizing multi-contact (MC4) wire splitters on two of the DC input ports. Low voltage drop schottky diodes are utilized on the DC port positive wire to prevent battery discharge through the PV modules. Except for the relay used to disconnect power to the battery charger, the MSHP and the HPWH were connected uninterrupted at the inverter output and operated with their native controls. Appliance loads are grounded to the buildings electrical distribution panel. The battery wiring is connected to the inverter DC input ports in ungrounded mode. A manual disconnect switch was connected in series with a high current capable low power contactor (12V controlled) via current monitor shunt. Watt-hour meters with respective current sensors are show at the inverter input and to each of the powered load.

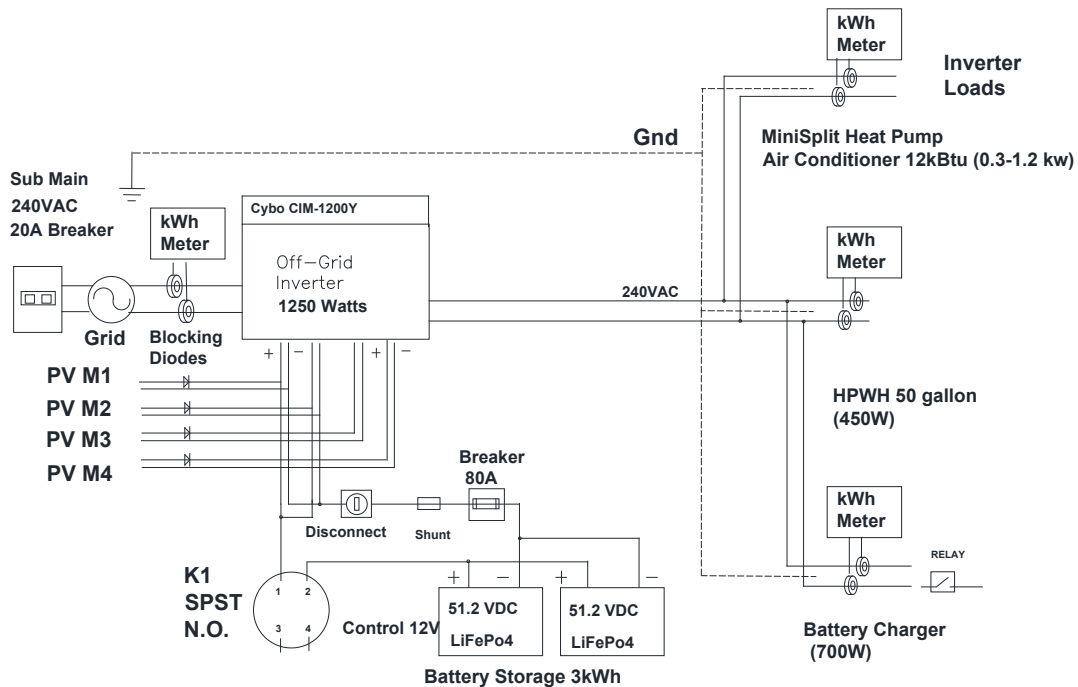

**Figure 13. Diagram of PV-GEMS Component and Wiring Connections**

An optimized system would consume all energy generation throughout the year. However, building loads are seasonal, varying highly with time of day and at times are less than the energy production potential. With the Cybo brand grid-assisted inverters, improved solar conversion is achieved when loads equal or slightly exceed the equivalent solar energy generated. When insufficient loads are present to the inverter at times of high solar capacity, the inverter limits the solar energy utilization. A strategy utilized by PV-GEMS is to enable battery charging (~700W) as an additional load to make more efficient use of available PV energy. Battery charging is enabled during daytime peak sun hours (11am-5pm,) but only when the system detects the HPWH is off due to limited available inverter capacity. Any excess solar energy that is stored in batteries can then be discharged at night, if there is load. System A (MHLab) provided battery discharge reaching as high as 75% of its storage capacity in the month of September (Figure 14). On average the battery supplied about 1.5 kwh per day or 48% of total storage capacity.

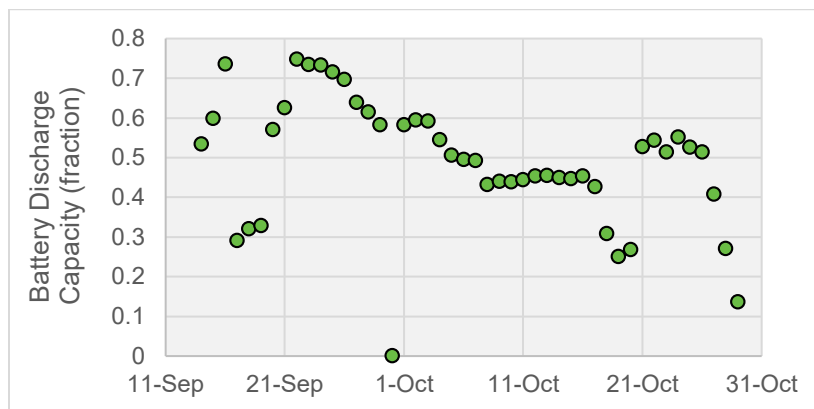

**Figure 14. Battery capacity expressed as a fraction of total capacity used for Pilot System A during September-Oct 2021**

The measured energy utilization is shown in Figure 15. Theoretical energy production by the PV modules, represented by the diagonal dashed line, exceeds the actual on-site energy consumption, due to load and energy generation time mismatch, and inverter inefficiencies. Prior to implementation of battery storage, the energy utilization was about 50% of theoretical max. When energy storage was included, the solar energy utilization increases to approximately 75%. Additional work to further increase the % energy utilization is proposed for Phase 2.

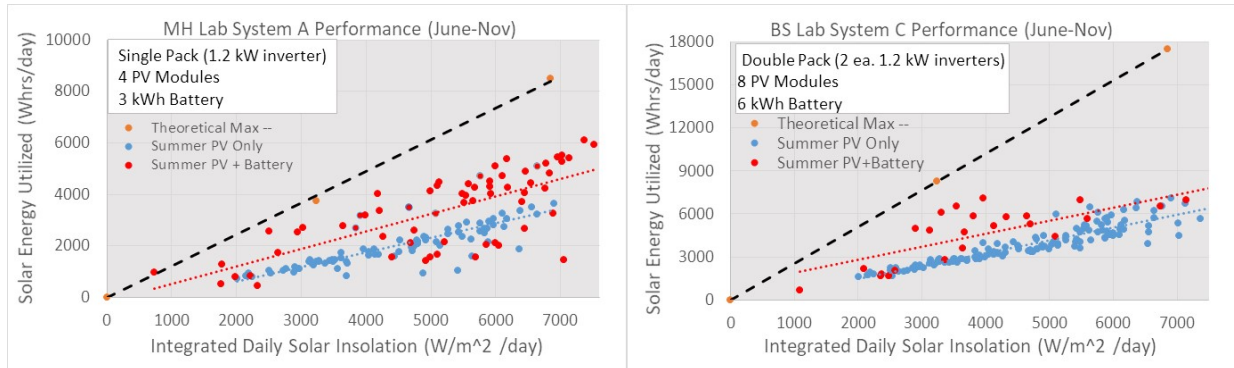

**Figure 15. Solar energy utilization by pilot systems. Excess solar energy stored in battery is utilized at night which brings performance (red data points) closer to optimization.**

## 4 Cost Modeling and Analysis

Costs of a future constructed PV-GEM system B deployed alongside of shallow retrofits are listed in Table 15. Cost reductions of 17% over retail are estimated to be available by volume pricing for the HPWH, MSHP, PV modules and balance of the system. Further cost reductions are utilized for the storage (48V LiFePo) by purchase of storage in bulk for eight (8) systems at a time (~\$20k min, \$395/kWh). Furthermore, a cost metric of \$0.24/watt, a price of available grid tied microinverters, is utilized for the inverter and assumes that the off-grid inverter produced in bulk could achieve the same price competitiveness.

**Table 15. Hardware costs of proposed typical PV-GEMS System B.**

System B component	Proposed	Cost metric	Notes
PV 1.2Kw <sub>p</sub>	\$614	\$0.49/watt	0.41/watt DC (NREL)
Inverter 1.2 KW	\$291	\$0.24/watt	APSystems \$291 = \$0.2426 / watt
Racking/_BOS	\$238	\$0.15-20/W	0.08 watt DC/0.18-0.28 wiring
HPWH (50 Gal)	\$1,257		
MSHP 18 kBtu	\$1,800		
Controller	\$825		
Battery Charger	\$332		<a href="https://evdrives.com/delta-q-ic650-on-board-48v-battery-charger-with-comm-port-940-0006/">https://evdrives.com/delta-q-ic650-on-board-48v-battery-charger-with-comm-port-940-0006/</a>
Storage 3kWh	\$1,184	\$394/kWh	NREL:\$253/kWh
<b>SubTotal</b>	<b>\$6,541</b>		
House, duct sealing and ceiling insulation retrofit	\$2414		
<b>Total</b>	<b>\$8955</b>		

Table 16 shows other costs, including a shed to act as a pre-packaged enclosure, along with installation, permits, fees, and profits (model source costs NREL<sup>5</sup>). The total installed product was estimated at \$17,215 including 6% sales tax. Ideally in Phase 2, the manufacturer achieves a design that will create an enclosure for much lower cost. In some states the product may be considered tax-free because it is for energy efficiency or because it has renewable energy. Other incentives may be possible. There are a number of proposals out for \$4000 incentives on retrofits that would achieve 35% energy savings. We have applied a \$251 solar credit and a \$4000 reduction in first cost through whatever reductions or incentives may be entailed for a net system cost of \$12,963. We used this value for conducting the cost effectiveness analysis.

**Table 16. Breakdown of non-hardware installed PV-GEMS system costs**

System Type	Supply chain (25%)	Sales	Labor + burden	Local Permit and Engineering Fees	Overhead and Profit (20%)	Shed, Dropped	SubTotal
PV-GEMS 1.2kW w/ 3kWh storage	\$300	\$456	\$1416	\$375	\$2206	\$2860	\$7285

Net present value analysis was conducted by allocating soft costs by heating and cooling, water heating, battery and PV, using a 10-year life for battery but with the cost of replacement coming down over time. The HPWH and MSHP were estimated at 15-year life and the photovoltaic system was estimated at a 30-year life. A fuel escalation rate of 3% and general inflation rate of 2.5% were used. A 15-year mortgage at 4.5% was applied.

Table 17 presents economic indicators of simple payback, net present value and savings to investment ratios based on \$12,963 in capital costs and averaging the savings provided from heat pump and electric resistance baseline older (1980s and earlier) homes for the simulated System B configuration (1.5-ton MSHP with 60-gallon HPWH, 3kWh battery and 1.2 kW solar system). As shown in Table 17, the economics for retrofitting old homes is rather good, particularly in cold climates.

**Table 17. PV-GEMS Economic Breakdown for a system with a net cost of \$12,963 after incentives or cost reductions applied to older (1980s and earlier) homes**

Average savings of HP and ER cases except Miami which is 100% ER (kWh)	EIA rate Sep-2021 \$/kWh	Annual Savings (\$)	Simple Payback (yrs)	15 year mortgage, 30 year analysis				
				Life Cycle Savings	Life Cycle Costs	Net Present Value	Savings to Investment Ratio	
Durango	17557	0.129	\$ 2,256	5.7	\$83,278	\$25,067	\$58,211	3.32
Portland	16652	0.113	\$ 1,878	6.9	\$59,908	\$25,067	\$34,841	2.39
Baltimore	14099	0.127	\$ 1,793	7.2	\$59,808	\$25,067	\$34,741	2.39
Atlanta	9295	0.126	\$ 1,172	11.1	\$33,960	\$25,067	\$8,893	1.35
Phoenix	8067	0.125	\$ 1,008	12.9	\$31,418	\$25,067	\$6,351	1.25
Miami	5925	0.119	\$ 702	18.5	\$19,180	\$25,067	-\$5,887	0.77

<sup>5</sup> <https://www.nrel.gov/docs/fy21osti/77324.pdf>



# Appendix A – Project Tasks and Milestones

**Table A1. Task and Milestone Summary Description**

<b>Task Number</b>	<b>Milestone Number</b>	<b>Milestone Description (Go/No-Go Decision Criteria)</b>
0.0		Intellectual Property Management Plan (IPMP)
	0.1	The IPMP agreed to by all relevant parties, signed and submitted to DOE for approval.
1.0		Obtain approval for research plan and finalize Phase 1 concept design
	1.1	Develop and obtain approval of research plan.
	1.2	Develop energy simulations to estimate energy savings and optimize component sizing and finalize Phase 1 concept designs
2.0		Acquire Phase 1 prototype system components
	2.1	Complete acquisition of components for two Phase 1 prototype systems.
	2.2	Complete benchtop assembly of components and controls for two Phase I prototype systems of differing capacity.
3.0		Assembly and installation in laboratories
	3.1	Complete installation of the two Phase 1 prototype systems in two separate labs.
	3.2	Complete calibration of laboratory data collection and control hardware.
4.0		Data collection and concept refinement
	4.1	Complete assessment of Phase 1 prototype system functionality.
	4.2	Complete assessment of Phase 1 prototype system performance targeting 75% reduction of energy use intensity for heating, cooling, and water heating.
5.0		ABC Collaborative Engagement
	5.1	Attend the ABC FOA Kickoff Meeting.
	5.2	Attend BTO's Peer Review in spring 2021 and participate in a possible one (1) day workshop
	5.3	Coordinate with the ABC Collaborative on identifying the elements of a whole building solution along with sites to demonstrate at
	5.4	Present project progress in a minimum of one (1) ABC Collaborative virtual meeting(s) of one hour each over the course of the award.
	5.5	Attend the 2021 Annual ABC Collaborative Summit
	5.6	Coordinate with the ABC Collaborative on commercialization activities.
6.0		Down Select Activities
6.1		Phase 2 Application Package
	6.1.1	Submit Phase 1 Technical Report
	6.1.2	Submit Phase 2 Project Proposal
	6.1.3	Submit Phase 2 Proposal Budget
	6.2.1	Present Phase 1 Progress

## Appendix B – List of Components

Components selected for prototype development are shown in the following tables. For prototype testing no external controllers were used and instead the data acquisition system was used to activate relays (e.g., battery charger activation) to achieve control of the PV-GEMS equipment as needed for proof of concept testing.

**Table B-1. List of components used for PV-GEMS systems.**

<b>Component</b>	<b>Manufacturer</b>	<b>Model Number</b>	<b>Details</b>
Micro-Inverters	Cybo	CIM 2500Y-2p	Twin Pack 2500W 240VAC Off-grid Inverter
PV Modules	Canadian Solar	CS1H-320MS HiDM- Black	Hi-density Mono PERC Module (320Wp)
Heat Pump Water Heater (HPWH)	Rheem	PROPH50 T2 RH375-30 PROPH80 T2 RH375-30	50 gallon hybrid HPWH 80 gallon Hybrid HPWH
MiniSplit Heat Pump (MSHP)	Fujitsu	Fujitsu RLS12 3Y Fujitsu RLS15 3Y	12kBtu/hr 15kBtu/hr
Battery – Storage	RELiON	48V030-GC2	LIPoF4 48V 1.5 kWhr (ea.)
Battery charger	DeltaQ	IC 650	48V Industrial battery charger
Switch Contactor	TC KILOVAC	EV200	Contactorm Form X SPST
Controller/Measurement	Campbell Scientific	CR1000X  SDM-SW8A	Measurement (24-bit) and Control Data Logger Pulse Input Peripheral (8-ch)
Power Meters	Continental Controls	WattNode WNB-240P	Watt-hour transducer/Power meter w/pulse output
Current Shunt	EMPRO	HA-10-50	10A DC ammeter

**Table B-2. Other supporting equipment.**

<b>Component</b>	<b>Manufacturer</b>	<b>Model Number</b>	<b>Description</b>
Power Supplies	Mastech	HY5020EX	Variable regulated switching power supply

## Appendix C – System Installation Photographs

The prototype systems used in Phase 1 of this program were tested in two laboratories at the FSEC Energy Center in Cocoa, FL. Components were purchased and installed in each laboratory where System A was installed in the Manufactured Housing Laboratory while System C was installed in the Building Science Laboratory. The photovoltaics modules selected were similar in size and capacity. The MSHP air conditioner and heat pump water heater were selected based on capacity chosen for each system. Other components used for the PV-GEMS hardware were identical and scaled in quantity to provide the required capacity.



**Figure C-1. Pilot System A was installed in the Manufactured Housing Lab (right) and Pilot System C was installed in the Building Science Lab (left).**



**Figure C-2. Photos of System C components installed in the Building Science Lab.**

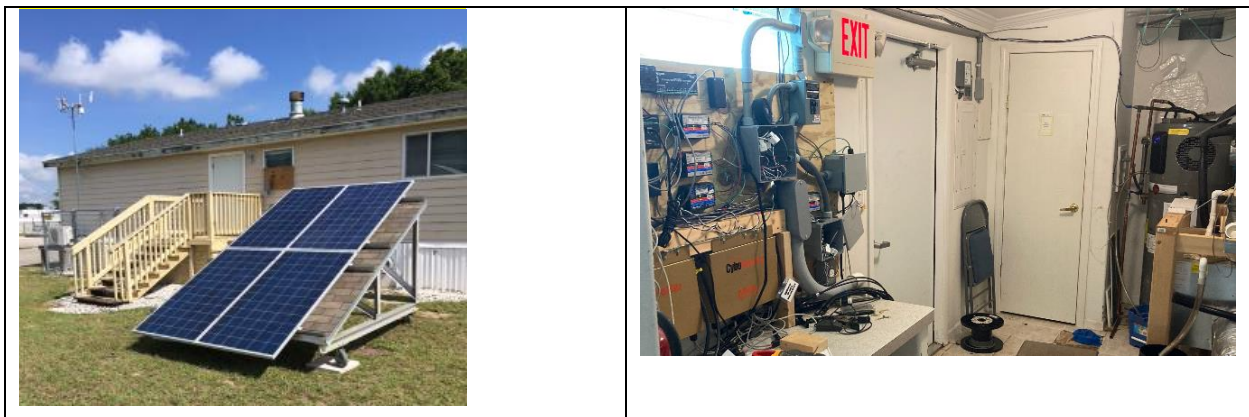

**Figure C-3. Photos of System C components installed in the Building Science Lab.**

## Appendix D – Building Characteristics

Details of the characteristics of the simulated houses are provided in this appendix. These characteristics were developed when possible from ResStock housing data.

### Example of ResStock Atlanta Characteristics

Characteristics: 2000 sqft (note that ResStock only has a 500 sqft granularity), single-story with slab on grade; garage (40% are two story) [Natural gas prototype is basement with uninsulated walls]

Vintage: 2000s [Vintage associated with insulation levels, but not correlated with fuel choices]

### **Insulation/Thermal Integrity**

Wall: R-11 (45% of stock); R-11(30%) [Uninsulated walls= 47%, but largely concentrated in buildings 1980s and earlier]

Ceiling: R-30 vented [both fuels have ~ 45% R-19 ceilings or less; highly vintage correlated.]

Foundation is uninsulated slab; Basement walls: Uninsulated (94%)

Windows: Single glazed (48%) [Electric and natural gas buildings have single glazed windows]

Infiltration: 15 ACH @50Pa (23% are better 10 ACH@50Pz)

Heating: Natural gas (54%) with AFUE 80%; Electric heat pump common (40%) [SEER 13 SEER; 7.7 HSPF]

Cooling: SEER 13 HP, HSPF 7.7 [Natural gas has older cooling systems: SEER 10, central]

Ducts: 20% leakage, uninsulated [Both fuels have poor ducts, newer homes have insulated ducts]

### **Water Heat**

Water heat: Electric resistance (58%); Gas (35%) [Natural gas heating also has natural gas water heating]

### **Other Opportunities**

Lighting 87% incandescent

Dryer: 91% electric

Washer: Energy Star (ES) Washer (66%; ES Dishwasher & Refrigerator, Cooking: Electric range (65%)

Ceilings: 46% insulated to only R-19 or less [No real difference between Gas and Electric]

**Simulation Parameters:**

The following tables describe in more detail the prototype building characteristics used in the simulations. “Improved” house characteristics shown in Tables 4-9 have the home energy improvements in orange text.

**Table D1. Appliance Assumptions for All Prototype Buildings**

<b>Appliance Characteristics</b>	<b>80s Base</b>	<b>80s Improved</b>
Refrigerator Annual Energy	1044.0	1044.0
Refrigerator Volume	25.0	25.0
Refrigerator Configuration	side-by-side freezer	side-by-side freezer
Cooking Range Fuel Type	Electric	Electric
Cooking Range Cook Top Energy Factor	0.74	0.74
Cooking Range Oven Energy Factor	0.11	0.11
Dish Washer Energy Guide Annual Energy	318.0	318.0
Dish Washer Capacity	8.0	8.0
Clothes Washer MEF	1.41	1.41
Clothes Washer Annual Energy Consumption Test	387.0	387.0
Clothes Washer Drum Volume	3.5	3.5
Clothes Dryer Fuel Type	Electric	Electric
Clothes Dryer Energy Factor	3.1	3.1
Clothes Dryer Auto Termination	Timer	Timer

**Table D2. Water Heating System Assumptions for All Baseline and “Improved” Buildings**

<b>Water Heater Characteristics</b>	<b>Electric / Heat Pump</b>	<b>Gas</b>
Water Heater Type	Tank	Tank
Water Heater Tank Size, Gallons	45	38
Water Heater Fuel Type	Electric	Gas
Water Heater Rated Energy Factor	0.92	0.59
Water Heater Setpoint, °F	125.0	125.0

**Table D3. HVAC System Assumptions for All Prototype Buildings**

<b>HVAC Characteristics</b>	<b>Electric Furnace</b>	<b>Gas Furnace</b>	<b>Heat Pump</b>
Mechanical Ventilation	None	None	None
Heating and Cooling Thermostat Setpoint <sup>ξ</sup> , °F/°F	68/75	68/75	68/75
Central Cooling System Type	Air Conditioner	Air Conditioner	Heat Pump
Central Cooling System Efficiency, SEER	13.0	13.0	13.0
Central Heating System Type	Electric Furnace	Gas Furnace	Heat Pump
Electric Furnace, AFUE	1.0	1.0	NA
Heat Pump, HSPF	NA	NA	7.7
Supplemental Heating System Type	NA	NA	Electric
Supplemental Heating System Efficiency, AFUE	NA	NA	1.0

ξ: Miami uses a thermostat heating and cooling setpoints of 71/75 °F/°F

**Table D4 Prototype Building Characteristics for Atlanta 80s and 90s Vintages**

<b>Building Characteristics</b>	<b>Base</b>	<b>80s Improved</b>	<b>90s Base</b>	<b>90s Improved</b>
House Type	Single Family House			
Total Floor Area, ft <sup>2</sup>	2198	2198	2198	2198
Total Conditioned Floor Area, ft <sup>2</sup>	1778	1778	1778	1778
Number of Bedrooms	3	3	3	3
Foundation Type	Slab-On-Grade	Slab-On-Grade	Slab-On-Grade	Slab-On-Grade
Infiltration, Living Space, ACH50	10.0	<b>6.0</b>	8.0	<b>6.0</b>
Infiltration, Garage, ACH50	10.0	<b>6.0</b>	8.0	<b>6.0</b>
Duct Leakage Total	0.15	<b>0.075</b>	0.1	<b>0.05</b>
Duct Insulation, R-Value	4.0	4.0	6.0	6.0
Lighting Fraction LED	0.20	<b>0.80</b>	0.20	<b>0.80</b>
Lighting Corridor LPD	0.50	0.50	0.50	0.50
Exterior Wall, Wood Stud Wall, with Stucco Finish (Cavity Depth, 3.5 Inch; Wall Framing Factor = 0.25; Wall stud-spacing = 16.0 Inch)	No Insulation	No Insulation	R-11	R-11
Window Wall Fraction (whole house)	0.25	0.25	0.25	0.25
Window Frame Material	Metal	Metal	Non-Metal	Non-Metal
Number of Panes	1	1	2	2
Window U-Factor	1.16	1.16	0.37	0.37
Window SHGC	0.76	0.76	0.30	0.30
Ceiling Insulation, R-Value	30.0	<b>38.0</b>	30.0	<b>38.0</b>
UA Ceiling Framing Factor	0.07	0.07	0.07	0.07
People, Living Space, People Count	2.64	2.64	2.64	2.64



**Table D5 Prototype Building Characteristics for Baltimore 80s and 90s Vintages**

<b>Building Characteristics</b>	<b>80s Base</b>	<b>80s Improved</b>	<b>90s Base</b>	<b>90s Improved</b>
House Type	Single Family House			
Total Floor Area, ft <sup>2</sup>	2198	2198	2198	2198
Total Conditioned Floor Area, ft <sup>2</sup>	1778	1778	1778	1778
Number of Bedrooms	3	3	3	3
Foundation Type	Unfinished Basement	Unfinished Basement	Unfinished Basement	Unfinished Basement
Infiltration, Living Space, ACH50	10.0	<b>6.0</b>	8.0	<b>6.0</b>
Infiltration, Garage, ACH50	10.0	<b>6.0</b>	8.0	<b>6.0</b>
Duct Leakage Total	0.15	<b>0.10</b>	0.10	<b>0.075</b>
Duct Insulation, R-Value	4.0	4.0	6.0	6.0
Lighting Fraction LED	0.20	<b>0.80</b>	0.20	<b>0.80</b>
Lighting Corridor LPD	0.50	0.50	0.50	0.50
Exterior Wall, Wood Stud Wall, with Stucco Finish (Cavity Depth, 3.5 Inch; Wall Framing Factor = 0.25; Wall stud-spacing = 16.0 Inch)	No Insulation	No Insulation	R-11	R-11
Window Wall Fraction (whole house)	0.25	0.25	0.25	0.25
Window Frame Material	Metal	Metal	Non-Metal	Non-Metal
Number of Panes	1	1	2	2
Window U-Factor	1.16	1.16	0.37	0.37
Window SHGC	0.76	0.76	0.30	0.30
Ceiling Insulation, R-Value	19.0	<b>38.0</b>	30.0	<b>38.0</b>
UA Ceiling Framing Factor	0.07	0.07	0.07	0.07
Unfinished Basement Wall Insulation	No-Insulation	No-Insulation	(R-5.0 c.i.)	(R-5.0 c.i.)
People, Living Space, People Count	2.64	2.64	2.64	2.64

**Table D6 Prototype Building Characteristics for Durango 80s and 90s Vintages**

<b>Building Characteristics</b>	<b>80s Base</b>	<b>80s Improved</b>	<b>90s Base</b>	<b>90s Improved</b>
House Type	Single Family House			
Total Floor Area, ft <sup>2</sup>	2198	2198	2198	2198
Total Conditioned Floor Area, ft <sup>2</sup>	1778	1778	1778	1778
Number of Bedrooms	3	3	3	3
Foundation Type	Unfinished Basement	Unfinished Basement	Unfinished Basement	Unfinished Basement
Infiltration, Living Space, ACH50	10.0	<b>6.0</b>	8.0	<b>6.0</b>
Infiltration, Garage, ACH50	10.0	<b>6.0</b>	8.0	<b>6.0</b>
Duct Leakage Total	0.15	<b>0.10</b>	0.10	<b>0.075</b>
Duct Insulation, R-Value	4.0	4.0	6.0	6.0
Lighting Fraction LED	0.20	<b>0.80</b>	0.20	<b>0.80</b>
Lighting Corridor LPD	0.50	0.50	0.50	0.50
Exterior Wall, Wood Stud Wall, with Stucco Finish (Cavity Depth, 3.5 Inch; Wall Framing Factor = 0.25; Wall stud-spacing = 16.0 Inch)	No Insulation	No Insulation	R-11	R-11
Window Wall Fraction (whole house)	0.25	0.25	0.25	0.25
Window Frame Material	Metal	Metal	Non-Metal	Non-Metal
Number of Panes	1	1	2	2
Window U-Factor	1.16	1.16	0.37	0.37
Window SHGC	0.76	0.76	0.30	0.30
Ceiling Insulation, R-Value	19.0	<b>38.0</b>	30.0	<b>38.0</b>
UA Ceiling Framing Factor	0.07	0.07	0.07	0.07
Unfinished Basement Wall Insulation	No-Insulation	No-Insulation	(R-5.0 c.i.)	(R-5.0 c.i.)
People, Living Space, People Count	2.64	2.64	2.64	2.64

**Table D7 Prototype Building Characteristics for Miami 80s and 90s Vintages**

<b>Building Characteristics</b>	<b>80s Base</b>	<b>80s Improved</b>	<b>90s Base</b>	<b>90s Improved</b>
House Type	Single Family House			
Total Floor Area, ft <sup>2</sup>	2198	2198	2198	2198
Total Conditioned Floor Area, ft <sup>2</sup>	1778	1778	1778	1778
Number of Bedrooms	3	3	3	3
Foundation Type	Slab-On-Grade	Slab-On-Grade	Slab-On-Grade	Slab-On-Grade
Infiltration, Living Space, ACH50	10.0	<b>6.0</b>	8.0	<b>6.0</b>
Infiltration, Garage, ACH50	10.0	<b>6.0</b>	8.0	<b>6.0</b>
Duct Leakage Total	0.15	<b>0.075</b>	0.10	<b>0.05</b>
Duct Insulation, R-Value	4.0	4.0	6.0	6.0
Lighting Fraction LED	0.20	<b>0.80</b>	0.20	<b>0.80</b>
Lighting Corridor LPD	0.50	0.50	0.50	0.50
Exterior Wall, CMU, without Interior Insulation (Thickness = 8.0; Framing Factor = 0.076; Furring Cavity Depth= 1.0; Furring Stud Spacing = 24)	Concrete Block-Hollow	Concrete Block-Hollow	Concrete Block-Hollow	Concrete Block-Hollow
Window Wall Fraction (whole house)	0.25	0.25	0.25	0.25
Window Frame Material	Metal	Metal	Non-Metal	Non-Metal
Number of Panes	1	1	2	2
Window U-Factor	1.16	1.16	0.37	0.37
Window SHGC	0.76	0.76	0.30	0.30
Ceiling Insulation, R-Value	19.0	<b>38.0</b>	30.0	<b>38.0</b>
UA Ceiling Framing Factor	0.07	0.07	0.07	0.07
People, Living Space, People Count	2.64	2.64	2.64	2.64

**Table D8 Prototype Building Characteristics for Phoenix 80s and 90s Vintages**

<b>Building Characteristics</b>	<b>80s Base</b>	<b>80s Improved</b>	<b>90s Base</b>	<b>90s Improved</b>
House Type	Single Family House			
Total Floor Area, ft <sup>2</sup>	2198	2198	2198	2198
Total Conditioned Floor Area, ft <sup>2</sup>	1778	1778	1778	1778
Number of Bedrooms	3	3	3	3
Foundation Type	Slab-On-Grade	Slab-On-Grade	Slab-On-Grade	Slab-On-Grade
Infiltration, Living Space, ACH50	10.0	<b>6.0</b>	8.0	<b>6.0</b>
Infiltration, Garage, ACH50	10.0	<b>6.0</b>	8.0	<b>6.0</b>
Duct Leakage Total	0.15	<b>0.075</b>	0.10	<b>0.05</b>
Duct Insulation, R-Value	4.0	4.0	6.0	6.0
Lighting Fraction LED	0.20	<b>0.80</b>	0.20	<b>0.80</b>
Lighting Corridor LPD	0.50	0.50	0.50	0.50
Exterior Wall, CMU, without Interior Insulation (Thickness = 8.0; Framing Factor = 0.076; Furring Cavity Depth = 1.0; Furring Stud Spacing = 24)	Concrete Block-Hollow	Concrete Block-Hollow	Concrete Block-Hollow	Concrete Block-Hollow
Window Wall Fraction (whole house)	0.25	0.25	0.25	0.25
Window Frame Material	Metal	Metal	Non-Metal	Non-Metal
Number of Panes	1	1	2	2
Window U-Factor	1.16	1.16	0.37	0.37
Window SHGC	0.76	0.76	0.30	0.30
Ceiling Insulation, R-Value	19.0	<b>38.0</b>	30.0	<b>38.0</b>
UA Ceiling Framing Factor	0.07	0.07	0.07	0.07
People, Living Space, People Count	2.64	2.64	2.64	2.64

**Table D9 Prototype Building Characteristics for Portland 80s and 90s Vintages**

<b>Building Characteristics</b>	<b>80s Base</b>	<b>80s Improved</b>	<b>90s Base</b>	<b>90s Improved</b>
House Type	Single Family House			
Total Floor Area, ft <sup>2</sup>	2198	2198	2198	2198
Total Conditioned Floor Area, ft <sup>2</sup>	1778	1778	1778	1778
Number of Bedrooms	3	3	3	3
Foundation Type	Crawlspace	Crawlspace	Crawlspace	Crawlspace
Infiltration, Living Space, ACH50	10.0	<b>6.0</b>	8.0	<b>6.0</b>
Infiltration, Garage, ACH50	10.0	<b>6.0</b>	8.0	<b>6.0</b>
Duct Leakage Total	0.15	<b>0.075</b>	0.10	<b>0.05</b>
Duct Insulation, R-Value	4.0	4.0	6.0	6.0
Lighting Fraction LED	0.20	<b>0.80</b>	0.20	<b>0.80</b>
Lighting Corridor LPD	0.50	0.50	0.50	0.50
Exterior Wall, Wood Stud Wall, with Stucco Finish (Cavity Depth, 3.5 Inch; Wall Framing Factor = 0.25; Wall stud-spacing = 16.0 Inch)	No Insulation	No Insulation	R-13	R-13
Window Wall Fraction (whole house)	0.25	0.25	0.25	0.25
Window Frame Material	Metal	Metal	Non-Metal	Non-Metal
Number of Panes	1	1	2	2
Window U-Factor	1.16	1.16	0.37	0.37
Window SHGC	0.76	0.76	0.30	0.30
Ceiling Insulation, R-Value	19.0	<b>38.0</b>	30.0	<b>38.0</b>
UA Ceiling Framing Factor	0.07	0.07	0.07	0.07
Crawl Space Ceiling Insulation (Ceiling Framing Factor = 0.13, Crawl ACH = 20.0)	No-Insulation	<b>R-13</b>	R-13	R-13
People, Living Space, People Count	2.64	2.64	2.64	2.64

## Appendix E – Simulated Energy Savings by End Use

Results are presented in kBtu/ft<sup>2</sup> for each simulated system for heating, cooling and water heating for each location, baseline and PV-GEMS system. The solar contribution modeled is also provided. A second table for each location indicates the percent savings of the end use saved is of the sum of the baseline cooling, heating and water heating site energy by use.

Abbreviations used in Tables:

**Old:** Refers to simulations run to represent homes built in 1980s and earlier (see Appendix D)

**90s:** Refers to simulations representing homes built in the 1990s (See Appendix D)

**ER** – Central Electric Resistance baseline

**HP** – Central Heat Pump baseline

**Gas** – Central Natural Gas Furnace

**A** – System A – 1-ton supplemental minisplit heat pump, 60-gallon heat pump water heater, 3kWH battery bank, 4 x310 Watt PV modules, 1.24 kW inverter

**B** – System B – 1.5-ton supplemental minisplit heat pump, 60-gallon heat pump water heater, 3kWH battery bank, 4 x310 Watt PV modules, 1.24 kW inverter

**C** – System C – 1.5-ton supplemental minisplit heat pump, 60-gallon heat pump water heater, 3kWH battery bank, 8 x310 Watt PV modules, 2.4 kW inverter



**Table E1 Simulated kBtu/ft2 Savings to Heating, Cooling and Hot Water Uses for Atlanta, GA**

Vintage + Baseline + System	Baseline Energy	Improved	Heating	Cooling	Water Heating	Subtotal	PV Contribution	Total
Old-ER-A	33.6	2.75	13.93	2.60	2.53	19.07	2.49	21.57
Old-ER-B	33.6	2.75	15.38	2.89	2.53	20.80	2.50	23.30
Old-ER-C	33.6	2.75	15.38	2.89	2.53	20.80	3.13	23.93
Old-HP-A	19.2	1.44	4.05	2.55	2.53	9.13	2.49	11.62
Old-HP-B	19.2	1.44	4.53	2.82	2.53	9.88	2.50	12.38
Old-HP-C	19.2	1.44	4.53	2.82	2.53	9.88	3.13	13.00
Old-Gas-A	44.0	4.07	18.39	2.76	5.82	26.96	2.51	29.47
Old-Gas-B	44.0	4.07	20.38	3.06	5.82	29.26	2.52	31.77
Old-Gas-C	44.0	4.07	20.38	3.06	5.82	29.26	3.16	32.42
90s-ER-A	17.9	1.24	6.53	1.90	2.53	10.96	2.13	13.09
90s-ER-B	17.9	1.24	6.61	1.91	2.53	11.03	2.14	13.18
90s-ER-C	17.9	1.24	6.61	1.91	2.53	11.03	2.48	13.51
90s-HP-A	12.1	0.67	2.06	1.85	2.53	6.44	2.13	8.57
90s-HP-B	12.1	0.67	2.09	1.85	2.53	6.47	2.14	8.62
90s-HP-C	12.1	0.67	2.09	1.85	2.53	6.47	2.48	8.95
90s-Gas-A	24.7	1.85	8.85	2.07	5.81	16.73	2.16	18.89
90s-Gas-B	24.7	1.85	9.00	2.08	5.81	16.89	2.17	19.06
90s-Gas-C	24.7	1.85	9.00	2.08	5.81	16.89	2.52	19.40

**Table E2. Percent Savings to Baseline Sum of Heating, Cooling and Hot Water Uses in Atlanta, GA**

Vintage + Baseline + System	Baseline Energy	Improved	Heating	Cooling	Water Heating	Subtotal	PV Contribution	Total
Old-ER-A		8%	42%	8%	8%	57%	7%	64%
Old-ER-B		8%	46%	9%	8%	62%	7%	69%
Old-ER-C		8%	46%	9%	8%	62%	9%	71%
Old-HP-A		8%	21%	13%	13%	48%	13%	61%
Old-HP-B		8%	24%	15%	13%	52%	13%	65%
Old-HP-C		8%	24%	15%	13%	52%	16%	68%
Old-Gas-A		9%	42%	6%	13%	61%	6%	67%
Old-Gas-B		9%	46%	7%	13%	67%	6%	72%
Old-Gas-C		9%	46%	7%	13%	67%	7%	74%
90s-ER-A		7%	36%	11%	14%	61%	12%	73%
90s-ER-B		7%	37%	11%	14%	62%	12%	74%
90s-ER-C		7%	37%	11%	14%	62%	14%	75%
90s-HP-A		6%	17%	15%	21%	53%	18%	71%
90s-HP-B		6%	17%	15%	21%	54%	18%	71%
90s-HP-C		6%	17%	15%	21%	54%	21%	74%
90s-Gas-A		8%	36%	8%	24%	68%	9%	77%
90s-Gas-B		8%	37%	8%	24%	68%	9%	77%
90s-Gas-C		8%	37%	8%	24%	68%	10%	79%

**Table E3 Simulated kBtu/ft<sup>2</sup> Savings to Heating, Cooling and Hot Water Uses for Baltimore, MD**

Vintage + Baseline + System	Baseline Energy	Improved	Heating	Cooling	Water Heating	Subtotal	PV Contribution	Total
Old-ER-A	53.6	7.82	25.94	1.44	2.25	29.63	2.51	32.15
Old-ER-B	53.6	7.82	30.93	1.72	2.25	34.91	2.55	37.46
Old-ER-C	53.6	7.82	30.93	1.72	2.25	34.91	3.59	38.50
Old-HP-A	27.8	3.58	8.67	1.39	2.26	12.32	2.51	14.83
Old-HP-B	27.8	3.58	10.19	1.67	2.25	14.11	2.55	16.66
Old-HP-C	27.8	3.58	10.19	1.67	2.25	14.11	3.59	17.70
Old-Gas-A	71.1	7.66	32.41	1.61	5.97	40.00	2.52	42.52
Old-Gas-B	71.1	7.66	39.55	1.88	5.97	47.41	2.55	49.96
Old-Gas-C	71.1	7.66	39.55	1.88	5.97	47.41	3.61	51.02
90s-ER-A	27.6	2.87	14.90	1.17	2.25	18.33	2.31	20.64
90s-ER-B	27.6	2.87	16.58	1.20	2.25	20.03	2.32	22.35
90s-ER-C	27.6	2.87	16.58	1.20	2.25	20.03	3.00	23.03
90s-HP-A	16.1	0.87	4.59	1.17	2.24	8.02	2.31	10.32
90s-HP-B	16.1	0.87	5.25	1.20	2.24	8.70	2.32	11.02
90s-HP-C	16.1	0.87	5.25	1.20	2.24	8.70	3.01	11.71
90s-Gas-A	38.2	2.69	19.45	1.28	5.92	26.65	2.33	28.97
90s-Gas-B	38.2	2.69	22.26	1.31	5.92	29.50	2.34	31.83
90s-Gas-C	38.2	2.69	22.26	1.31	5.92	29.50	3.05	32.55

**Table E4 Percent Savings to Baseline Sum of Heating, Cooling and Hot Water Uses in Baltimore, MD**

Vintage + Baseline + System	Baseline Energy	Improved	Heating	Cooling	Water Heating	Subtotal	PV Contribution	Total
Old-ER-A		15%	48%	3%	4%	55%	5%	60%
Old-ER-B		15%	58%	3%	4%	65%	5%	70%
Old-ER-C		15%	58%	3%	4%	65%	7%	72%
Old-HP-A		13%	31%	5%	8%	44%	9%	53%
Old-HP-B		13%	37%	6%	8%	51%	9%	60%
Old-HP-C		13%	37%	6%	8%	51%	13%	64%
Old-Gas-A		11%	46%	2%	8%	56%	4%	60%
Old-Gas-B		11%	56%	3%	8%	67%	4%	70%
Old-Gas-C		11%	56%	3%	8%	67%	5%	72%
90s-ER-A		10%	54%	4%	8%	66%	8%	75%
90s-ER-B		10%	60%	4%	8%	73%	8%	81%
90s-ER-C		10%	60%	4%	8%	73%	11%	83%
90s-HP-A		5%	29%	7%	14%	50%	14%	64%
90s-HP-B		5%	33%	7%	14%	54%	14%	68%
90s-HP-C		5%	33%	7%	14%	54%	19%	73%
90s-Gas-A		7%	51%	3%	15%	70%	6%	76%
90s-Gas-B		7%	58%	3%	15%	77%	6%	83%
90s-Gas-C		7%	58%	3%	15%	77%	8%	85%

**Table E5 Simulated kBtu/ft<sup>2</sup> Savings to Heating, Cooling and Hot Water Uses for Durango, CO**

Vintage + Baseline + System	Baseline Energy	Improved	Heating	Cooling	Water Heating	SubTotal	PV Contribution	Total
Old-ER-A	70.8	11.97	31.92	0.58	2.00	34.50	3.11	37.61
Old-ER-B	70.8	11.97	38.57	0.67	2.00	41.24	3.15	44.39
Old-ER-C	70.8	11.97	38.57	0.67	2.00	41.24	4.28	45.53
Old-HP-A	40.9	7.35	14.68	0.58	2.00	17.26	3.11	20.37
Old-HP-B	40.9	7.35	17.18	0.68	1.99	19.85	3.15	22.99
Old-HP-C	40.9	7.35	17.18	0.68	1.99	19.85	4.28	24.12
Old-Gas-A	93.4	10.16	37.89	0.70	6.16	44.75	3.13	47.88
Old-Gas-B	93.4	10.16	47.35	0.77	6.16	54.29	3.17	57.46
Old-Gas-C	93.4	10.16	47.35	0.77	6.16	54.29	4.35	58.64
90s-ER-A	36.7	4.32	19.56	0.28	1.99	21.83	2.66	24.49
90s-ER-B	36.7	4.32	22.84	0.27	1.99	25.11	2.68	27.79
90s-ER-C	36.7	4.32	22.84	0.27	1.99	25.11	3.55	28.65
90s-HP-A	21.3	1.26	6.62	0.32	1.98	8.92	2.68	11.60
90s-HP-B	21.3	1.26	8.02	0.31	1.98	10.32	2.70	13.02
90s-HP-C	21.3	1.26	8.02	0.31	1.98	10.32	3.59	13.91
90s-Gas-A	50.4	3.37	24.51	0.34	6.08	30.92	2.69	33.61
90s-Gas-B	50.4	3.37	29.70	0.33	6.08	36.10	2.72	38.82
90s-Gas-C	50.4	3.37	29.70	0.33	6.08	36.10	3.63	39.73

**Table E6 Percent Savings to Baseline Sum of Heating, Cooling and Hot Water Uses in Durango, CO**

Vintage + Baseline + System	Baseline Energy	Improved	Heating	Cooling	Water Heating	SubTotal	PV Contribution	Total
Old-ER-A		17%	45%	1%	3%	49%	4%	53%
Old-ER-B		17%	54%	1%	3%	58%	4%	63%
Old-ER-C		17%	54%	1%	3%	58%	6%	64%
Old-HP-A		18%	36%	1%	5%	42%	8%	50%
Old-HP-B		18%	42%	2%	5%	49%	8%	56%
Old-HP-C		18%	42%	2%	5%	49%	10%	59%
Old-Gas-A		11%	41%	1%	7%	48%	3%	51%
Old-Gas-B		11%	51%	1%	7%	58%	3%	62%
Old-Gas-C		11%	51%	1%	7%	58%	5%	63%
90s-ER-A		12%	53%	1%	5%	59%	7%	67%
90s-ER-B		12%	62%	1%	5%	68%	7%	76%
90s-ER-C		12%	62%	1%	5%	68%	10%	78%
90s-HP-A		6%	31%	1%	9%	42%	13%	54%
90s-HP-B		6%	38%	1%	9%	48%	13%	61%
90s-HP-C		6%	38%	1%	9%	48%	17%	65%
90s-Gas-A		7%	49%	1%	12%	61%	5%	67%
90s-Gas-B		7%	59%	1%	12%	72%	5%	77%
90s-Gas-C		7%	59%	1%	12%	72%	7%	79%

**Table E7 Simulated kBtu/ft<sup>2</sup> Savings to Heating, Cooling and Hot Water Uses for Miami, FL**

Vintage + Baseline + System	Baseline Energy	Improved	Heating	Cooling	Water Heating	Subtotal	PV Contribution	Total
Old-ER-A	15.5	1.63	0.17	6.27	2.03	8.46	2.72	11.18
Old-ER-B	15.5	1.63	0.17	6.45	2.03	8.65	2.72	11.37
Old-ER-C	15.5	1.63	0.17	6.45	2.03	8.65	3.33	11.98
Old-Gas-A	18.6	1.85	0.27	6.52	4.52	11.31	2.74	14.04
Old-Gas-B	18.6	1.85	0.27	6.73	4.52	11.53	2.75	14.27
Old-Gas-C	18.6	1.85	0.27	6.73	4.52	11.53	3.39	14.92
90s-ER-A	12.9	0.84	0.03	4.86	2.02	6.91	2.55	9.46
90s-ER-B	12.9	0.84	0.03	4.85	2.02	6.90	2.56	9.46
90s-ER-C	12.9	0.84	0.03	4.85	2.02	6.90	2.97	9.87
90s-Gas-A	15.8	0.94	0.06	5.06	4.52	9.63	2.57	12.21
90s-Gas-B	15.8	0.94	0.06	5.06	4.52	9.64	2.59	12.22
90s-Gas-C	15.8	0.94	0.06	5.06	4.52	9.64	3.03	12.66

**Table E8 Percent Savings to Baseline Sum of Heating, Cooling and Hot Water Uses in Miami, FL**

Vintage + Baseline + System	Baseline Energy	Improved	Heating	Cooling	Water Heating	Subtotal	PV Contribution	Total
Old-ER-A		10%	1%	40%	13%	54%	17%	72%
Old-ER-B		10%	1%	42%	13%	56%	18%	73%
Old-ER-C		10%	1%	42%	13%	56%	21%	77%
Old-Gas-A		10%	1%	35%	24%	61%	15%	75%
Old-Gas-B		10%	1%	36%	24%	62%	15%	77%
Old-Gas-C		10%	1%	36%	24%	62%	18%	80%
90s-ER-A		7%	0%	38%	16%	54%	20%	74%
90s-ER-B		7%	0%	38%	16%	54%	20%	74%
90s-ER-C		7%	0%	38%	16%	54%	23%	77%
90s-Gas-A		6%	0%	32%	29%	61%	16%	77%
90s-Gas-B		6%	0%	32%	29%	61%	16%	78%
90s-Gas-C		6%	0%	32%	29%	61%	19%	80%

**Table E9 Simulated kBtu/ft<sup>2</sup> Savings to Heating, Cooling and Hot Water Uses for Phoenix, AZ**

Vintage + Baseline + System	Baseline Energy	Improved	Heating	Cooling	Water Heating	Subtotal	PV Contribution	Total
Old-ER-A	24.7	3.11	2.01	8.24	1.76	12.01	2.94	14.95
Old-ER-B	24.7	3.11	2.01	9.64	1.76	13.41	2.96	16.38
Old-ER-C	24.7	3.11	2.01	9.64	1.76	13.41	3.87	17.28
Old-HP-A	22.5	2.64	0.17	6.99	1.76	10.28	2.94	13.21
Old-HP-B	22.5	2.64	0.20	8.31	1.76	11.62	2.96	14.59
Old-HP-C	22.5	2.64	0.20	8.31	1.76	11.62	3.87	15.49
Old-Gas-A	28.5	3.59	2.82	8.39	4.17	15.38	2.95	18.33
Old-Gas-B	28.5	3.59	2.82	9.82	4.17	16.81	2.98	19.79
Old-Gas-C	28.5	3.59	2.82	9.82	4.17	16.81	3.90	20.71
90s-ER-A	16.9	1.23	0.54	6.20	1.76	8.50	2.63	11.14
90s-ER-B	16.9	1.23	0.54	6.82	1.76	9.12	2.64	11.76
90s-ER-C	16.9	1.23	0.54	6.82	1.76	9.12	3.19	12.31
90s-HP-A	16.1	1.11	-0.13	4.90	1.76	7.88	2.63	10.51
90s-HP-B	16.1	1.11	-0.05	5.42	1.76	8.48	2.64	11.11
90s-HP-C	16.1	1.11	-0.05	5.42	1.76	8.48	3.19	11.66
90s-Gas-A	20.0	1.39	0.85	6.31	4.16	11.31	2.65	13.96
90s-Gas-B	20.0	1.39	0.85	7.00	4.16	12.00	2.66	14.66
90s-Gas-C	20.0	1.39	0.85	7.00	4.16	12.00	3.23	15.24

**Table E10 Percent Savings to Baseline Sum of Heating, Cooling and Hot Water Uses in Phoenix, AZ**

Vintage + Baseline + System	Baseline Energy	Improved	Heating	Cooling	Water Heating	Subtotal	PV Contribution	Total
Old-ER-A		13%	8%	33%	7%	49%	12%	61%
Old-ER-B		13%	8%	39%	7%	54%	12%	66%
Old-ER-C		13%	8%	39%	7%	54%	16%	70%
Old-HP-A		12%	1%	31%	8%	46%	13%	59%
Old-HP-B		12%	1%	37%	8%	52%	13%	65%
Old-HP-C		12%	1%	37%	8%	52%	17%	69%
Old-Gas-A		13%	10%	29%	15%	54%	10%	64%
Old-Gas-B		13%	10%	34%	15%	59%	10%	69%
Old-Gas-C		13%	10%	34%	15%	59%	14%	73%
90s-ER-A		7%	3%	37%	10%	50%	16%	66%
90s-ER-B		7%	3%	40%	10%	54%	16%	70%
90s-ER-C		7%	3%	40%	10%	54%	19%	73%
90s-HP-A		7%	-1%	30%	11%	49%	16%	65%
90s-HP-B		7%	0%	34%	11%	53%	16%	69%
90s-HP-C		7%	0%	34%	11%	53%	20%	72%
90s-Gas-A		7%	4%	32%	21%	57%	13%	70%
90s-Gas-B		7%	4%	35%	21%	60%	13%	73%
90s-Gas-C		7%	4%	35%	21%	60%	16%	76%

**Table E11 Simulated kBtu/ft<sup>2</sup> Savings to Heating, Cooling and Hot Water Uses for Portland, OR**

Vintage + Baseline + System	Baseline Energy	Improved	Heating	Cooling	Water Heating	Subtotal	PV Contribution	Total
Old-ER-A	57.7	8.42	35.76	0.68	2.61	39.05	2.10	41.14
Old-ER-B	57.7	8.42	41.14	0.85	2.61	44.60	2.11	46.71
Old-ER-C	57.7	8.42	41.14	0.85	2.61	44.60	2.98	47.58
Old-HP-A	26.0	3.07	10.11	0.68	2.61	13.40	2.10	15.49
Old-HP-B	26.0	3.07	11.65	0.84	2.61	15.10	2.11	17.21
Old-HP-C	26.0	3.07	11.65	0.84	2.61	15.10	2.98	18.08
Old-Gas-A	76.6	12.00	46.86	0.71	6.22	53.78	2.10	55.88
Old-Gas-B	76.6	12.00	54.35	0.88	6.22	61.44	2.11	63.55
Old-Gas-C	76.6	12.00	54.35	0.88	6.22	61.44	3.00	64.43
90s-ER-A	26.1	1.99	16.54	0.64	2.62	19.80	1.75	21.55
90s-ER-B	26.1	1.99	17.01	0.68	2.62	20.31	1.75	22.06
90s-ER-C	26.1	1.99	17.01	0.68	2.62	20.31	2.34	22.64
90s-HP-A	13.9	0.55	4.72	0.62	2.62	7.96	1.75	9.70
90s-HP-B	13.9	0.55	4.91	0.66	2.62	8.19	1.75	9.94
90s-HP-C	13.9	0.55	4.91	0.66	2.62	8.19	2.34	10.53
90s-Gas-A	36.8	3.36	22.90	0.67	6.21	29.77	1.76	31.52
90s-Gas-B	36.8	3.36	23.85	0.70	6.21	30.75	1.76	32.51
90s-Gas-C	36.8	3.36	23.85	0.70	6.21	30.75	2.37	33.12

**Table E12 Percent Savings to Baseline Sum of Heating, Cooling and Hot Water Uses in Portland, OR**

Vintage + Baseline + System	Baseline Energy	Improved	Heating	Cooling	Water Heating	Subtotal	PV Contribution	Total
Old-ER-A		15%	62%	1%	5%	68%	4%	71%
Old-ER-B		15%	71%	1%	5%	77%	4%	81%
Old-ER-C		15%	71%	1%	5%	77%	5%	82%
Old-HP-A		12%	39%	3%	10%	52%	8%	60%
Old-HP-B		12%	45%	3%	10%	58%	8%	66%
Old-HP-C		12%	45%	3%	10%	58%	11%	70%
Old-Gas-A		16%	61%	1%	8%	70%	3%	73%
Old-Gas-B		16%	71%	1%	8%	80%	3%	83%
Old-Gas-C		16%	71%	1%	8%	80%	4%	84%
90s-ER-A		8%	63%	2%	10%	76%	7%	83%
90s-ER-B		8%	65%	3%	10%	78%	7%	85%
90s-ER-C		8%	65%	3%	10%	78%	9%	87%
90s-HP-A		4%	34%	4%	19%	57%	13%	70%
90s-HP-B		4%	35%	5%	19%	59%	13%	71%
90s-HP-C		4%	35%	5%	19%	59%	17%	76%
90s-Gas-A		9%	62%	2%	17%	81%	5%	86%
90s-Gas-B		9%	65%	2%	17%	83%	5%	88%
90s-Gas-C		9%	65%	2%	17%	83%	6%	90%



## Appendix F – Aggregate Technical Potential

The U.S. technical potential energy savings for HVACWH was estimated from EIA 2015 RECS data for each of the five BA climate zones. The energy savings by climate zone were calculated using the spreadsheet “Residential\_Pivot\_Table\_Tool\_using\_RECS\_2015\_Data.xlsx” and percent total site energy savings determined using EnergyPlus simulation in six cities. The energy savings potential of the cities were assumed to represent the five climate zones: Durango, CO for Cold/Very-Cold climate zones, Phoenix, AZ for Hot-Dry/Mixed-Dry climate zone, Miami, FL for hot-humid, Portland, OR for Marine, and Atlanta, GA and Baltimore, MD for mixed-humid climate zones. The percent savings for each city are an average value determined from EnergyPlus simulation of six different configurations consisting of three central system heating types and two housing vintages for the 1.5 Ton MSHP 4 Panels (1.24 kW) PV-GEMS packaged technical solution. Figure F1 shows the average energy savings in percent for each of the five climate zones determined using EnergyPlus Simulation.

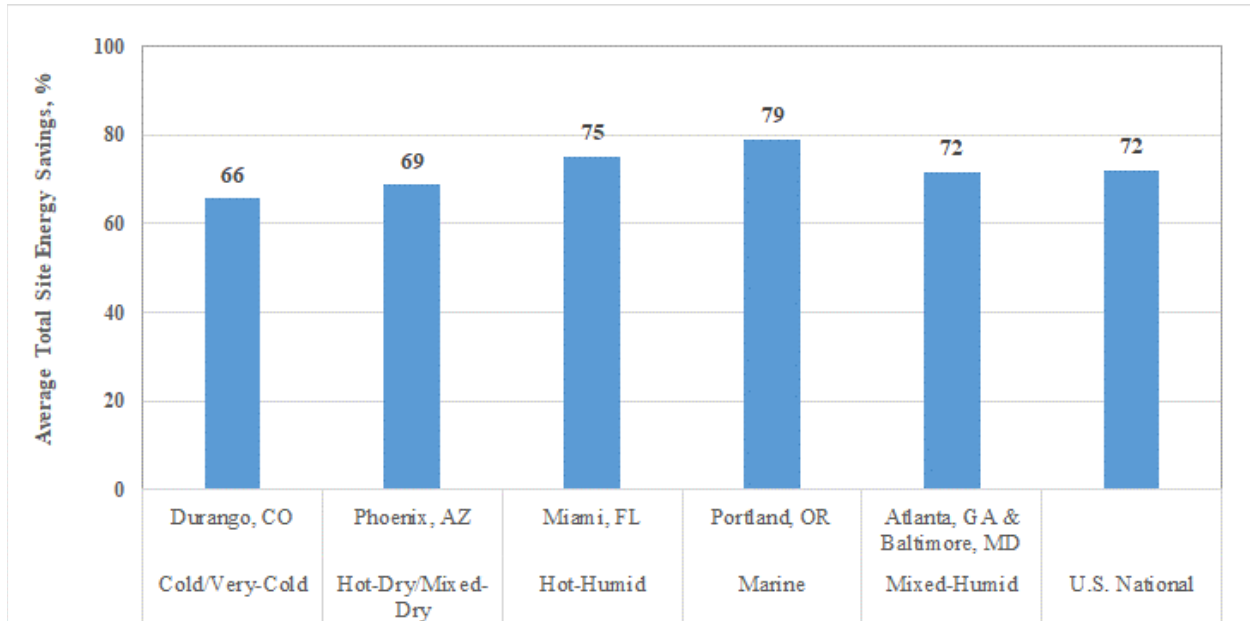

**Figure F1. Total Site HVACWH Energy Savings Potential for Five Climate Zones in Percent**

Housing characteristics used in the technical potential energy savings calculation for each climate zones are summarized in Table F1.

**Table F1. Housing Characteristics Included in Technical Potential Energy Savings Calculation**

House Characteristics	Included In the Analysis
Housing Type	Mobile, Single Family Attached and Single Family Detached Homes
BA Climate Zones	Cold/Very-Cold, Hot-Dry/Mixed-Dry, Hot-Humid, Marine, and Mixed-Humid
Census Division, Location Type, Facade Type	All
Year Built	All Except 2000s
Heating Equipment	Built furnace, Central Furnace, Heat Pump, Heater Burning Gas/Oil/Kerosene
Cooling Equipment	Both Central and Individual Units, Central AC

Figure F2 shows the technical potential HVACWH site energy savings by climate zones estimated using the total percent site energy savings in Figure F1, the housing characteristics in Table F1, and the EIA 2015 RECS data spreadsheet tool.

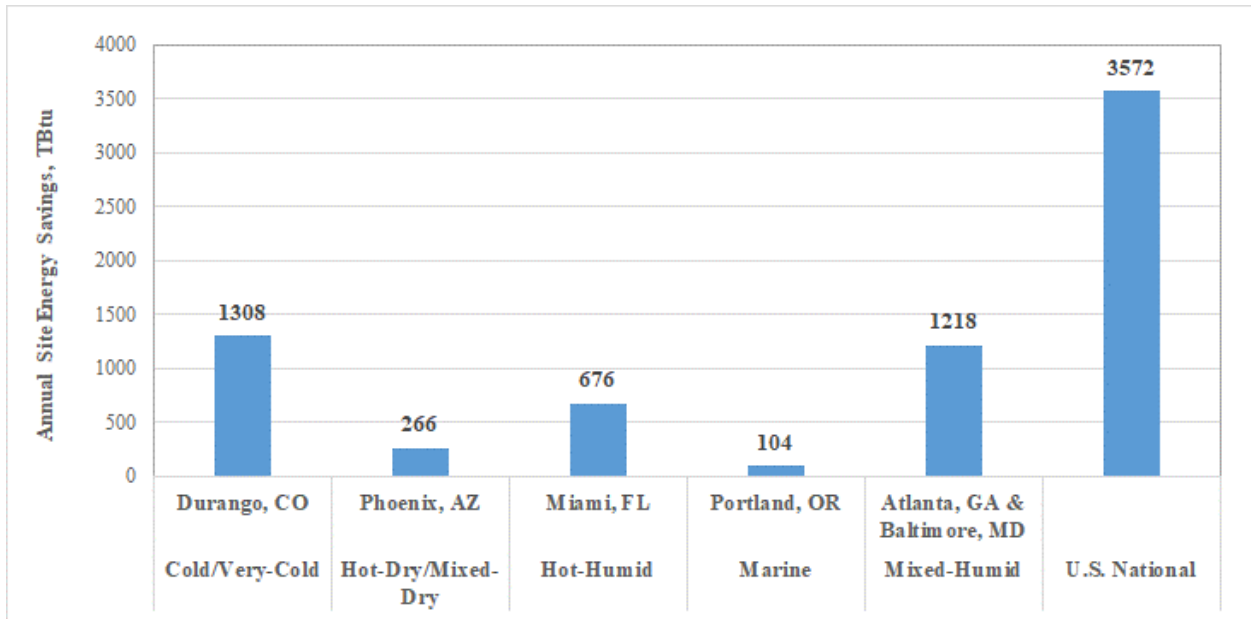

**Figure F2. Technical Potential HVACWH Site Energy Savings by Climate Zones and U.S. Total**