



# THE HARVEST HOME

U.S. DEPARTMENT OF ENERGY  
CHALLENGE HOME STUDENT DESIGN COMPETITION



# THE HARVEST HOME

U.S DEPARTMENT OF ENERGY CHALLENGE  
HOME STUDENT DESIGN COMPETITION



ROCKY  
MOUNTAIN  
INSTITUTE



RYERSON  
UNIVERSITY



Architectural  
Science  
Ryerson

## THE TEAM

Mark Gorgolewski

Paul Floerke

Vincent Hui

Russell Richman

Vera Straka

Patrick Andres

Matthew Carlsson

Antonio Cunha

Mark Grimsrud

Denver Jermyn

Moe Otsubo

Matthew Suriano

Filip Tisler

Matthew Tokarik

German Vaisman

## CONTENTS

01   Introduction	1
02   Team Qualifications	6
03   Design & Construction Goals	8
04   Financial Analysis	25
05   Envelope Durability	32
06   Indoor Air Quality Evaluation	42
07   Space Conditioning	45
08   Domestic Hot Water	54
09   Lighting & Appliances	61
10   Zero Net Energy Use	70
11   Construction Documentation	74
12   Additional Documentation	96



## 01.1 PROJECT INTRODUCTION

To harvest in the traditional sense of the term refers to the gathering of agricultural crops - a collection of resources made possible by the cycles of nature. The Harvest Home expands this definition beyond the agricultural context through the exploitation of natural solar and precipitation cycles in pursuit of superior building performance made possible through passive, contextually informed, simplistic design. The home aims to become a model for affordable sustainable residential construction toward of new standard that is accessible to the average North American home owner.

Designed in response to the Denver Super-Efficient Housing Challenge hosted by the Rocky Mountain Institute in partnership with the Denver Housing Authority, the Harvest Home is a row-house prototype designed for construction on a currently unused urban plot in the Curtis Park Neighborhood of Denver, Colorado. The previously occupied plot of land currently features a community garden that will become a central feature of the sustainable row-house development. The Harvest Home proposal is conceived as a row of five nearly identical single-family residential units. The following proposal focuses on the design and construction of a single mid-row unit.

The Harvest Home boasts an open concept ground floor plan allowing direct and ambient natural light to penetrate its modest footprint, while allowing maximum occupant flexibility. Services to kitchen and bathroom spaces are centralized to reduce inefficiencies and expenses associated with extensive duct and pipe runs. Opposite the centralized service wall, a generous gallery style stair extends from the ground to the upper levels providing ample storage space below. A central corridor at the upper level extends from the primary bedroom at the home`s rear to serve a full family bath and secondary bedroom at the North facade. An additional stair rises from the upper corridor to a multi-purpose loft space and adjacent roof terrace.

Increased environmental awareness and socio-economic changes across North America are creating a demand for houses that are more affordable, more energy- and resource-efficient, and more responsive to changing demographics. The Harvest Home, with its minimal footprint and high regard for constructability and performance is a prototype for the future of sustainable single-family residential construction. Through close consideration to all facets of the context the building significantly reduces resource consumption while maintaining an aesthetically pleasant, comfortable and flexible home.

## 01.2 PROJECT LOCATION

Situated less than two miles from Denver, Colorado's downtown core, the Harvest Home is located within the heart of the city's Curtis Park Community. Part of the greater Five-Points Neighborhood, the site is located directly East of the city's central business core. Bordered by Lawrence St. to the North, Arapahoe St. to the South, 25th Street to the West and 26th St. to the East, the plot measures approximately 2.75 acres in area. The site is directly accessible via multiple public transit routes, and a designated bicycle path.

A variety of educational facilities, art galleries, commercial outlets and other community amenities are located within a five minute walk. The currently unoccupied site features a large community garden at its West extent, promising to become a central feature of its redevelopment plan.

With this current infrastructure in place, the proposed location for the Harvest Home development provides ample opportunity for an environmentally conscious lifestyle beyond the individual residence. The Harvest Home development is envisioned as a key component of this sustainable urban community.



Aerial View to South West





North-East at Lawrence St.



South-East at 25th St.



Aerial Site Image



North-West at 26th St.



South-West at Arapahoe St.

## 01.3 CLIMATE DATA

The Harvest Home is developed employing a rigorous process to ensure that the final design addresses the needs of the inhabitants while respecting the natural rhythms of the local climate. Local conditions are assessed to determine a plan of action for integrating the home into the surrounding biosphere. A summary of the project site climatic factors investigated is included in Table 01.3-A.

The investigation reveals that the site receives a significant amount of solar energy, thus offering a valuable resource for providing heat in Denver's cold climate. In order to take advantage of the solar resource, careful design considerations are made to incorporate passive solar features from the onslaught of the design process. This wholistic, design-oriented approach to sustainability, renders the Passive House Standard a natural target for the Harvest Home proposal.

The relatively low amount of precipitation the site receives per annum requires close attention to mitigating interruptions in the natural hydrological cycle. This factor demands that the project team incorporate the use of low-impact development technology for storm water management.

Table 01.3-A: Site Climate Factor Summary

Denver, Colorado	Values
Climate Factors	
International Energy Conservation Code Climate (IECC) Region <sup>1</sup>	5
Total Annual Precipitation (inches) <sup>2</sup>	15.4
Annual Average Sunshine Hours (hrs) <sup>2</sup>	3115
Annual Global Solar Radiation (kBTU/ft <sup>2</sup> -yr) <sup>3</sup>	530.7
Elevation (feet above sea level) <sup>4</sup>	5430
Heating Degree Days (base 65°F, °F-day) <sup>4</sup>	5942
Cooling Degree Days (base 65°F, °F-day) <sup>4</sup>	777
ASHRAE 99.6% Heating DB (°F) <sup>4</sup>	0.7
ASHRAE 99% Heating DB (°F) <sup>4</sup>	6.9
ASHRAE 0.4% Cooling DB/MCWB (°F) <sup>4</sup>	94.3/60.3
ASHRAE 1% Cooling DB/MCWB (°F) <sup>4</sup>	91.8/60.0
EPA Radon Zone <sup>5</sup>	1

NOTES: Acronyms:  
 DB: Dry Bulb Temperature  
 MCWB: Mean Coincident Wet Bulb Temperature

Sources:

<sup>1</sup> <http://1.usa.gov/1f9v11>

<sup>2</sup> [www.denver.climateps.com](http://www.denver.climateps.com)

<sup>3</sup> Passive House Institute United States (PHIUS) Climate Data for Denver Int'l Airport

<sup>4</sup> ASHRAE (2009) Appendix: Design Conditions for Selected Locations

<sup>5</sup> EPA Map of Radon Zones (EPA-402-R-93-071)

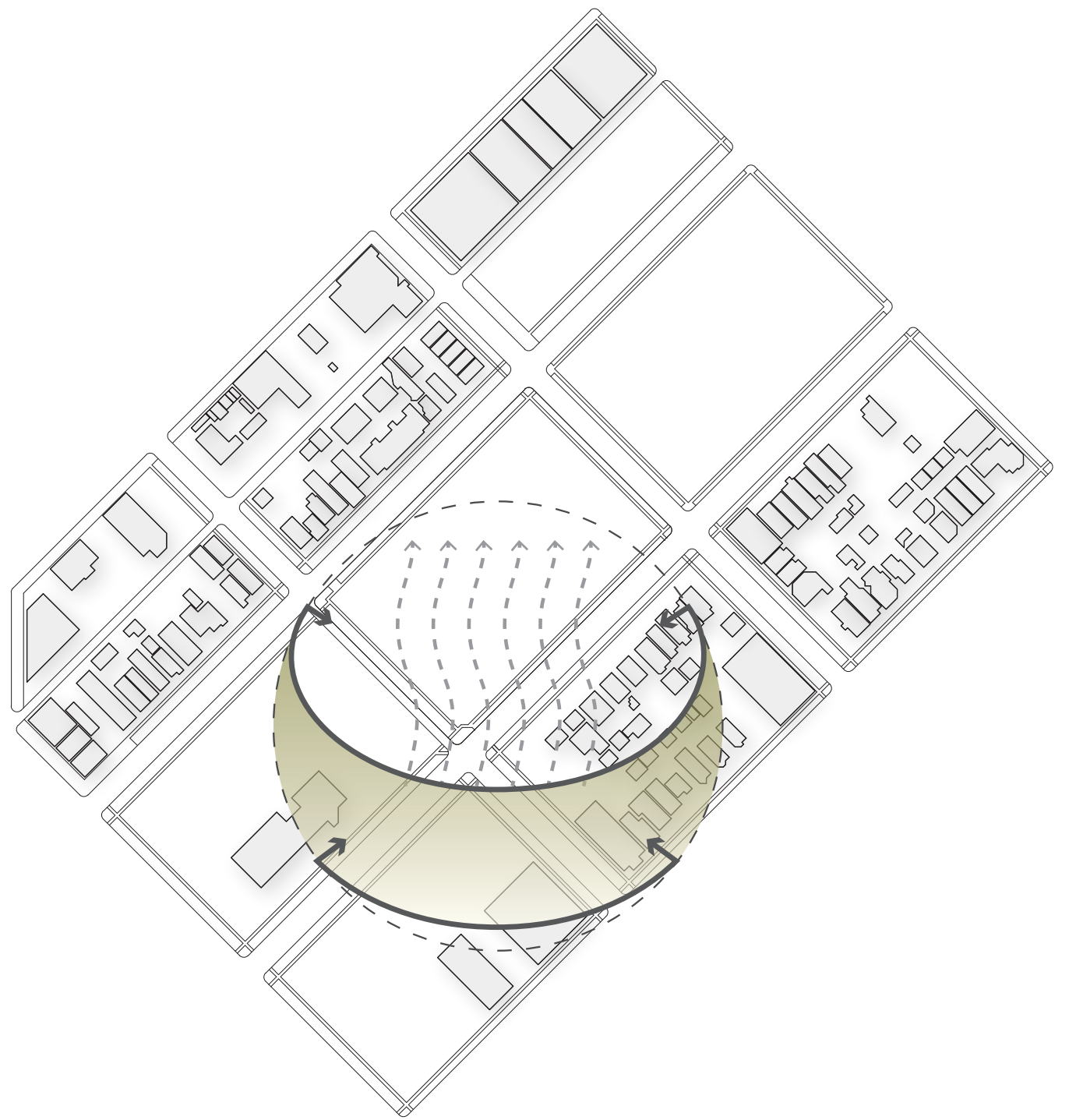

Existing Site Plan - Solar Orientation & Prevailing Wind

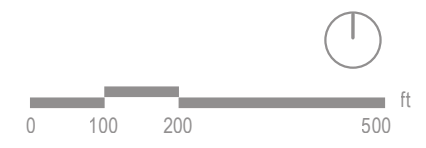
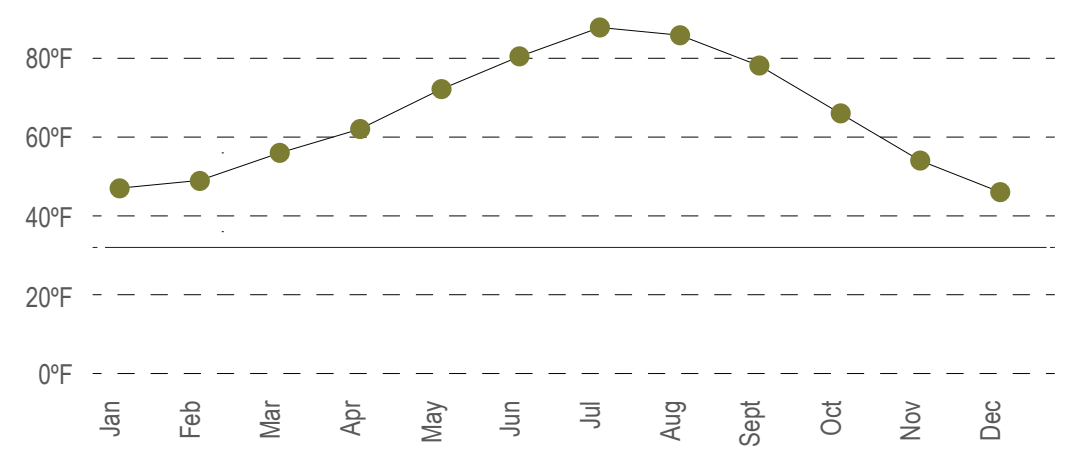
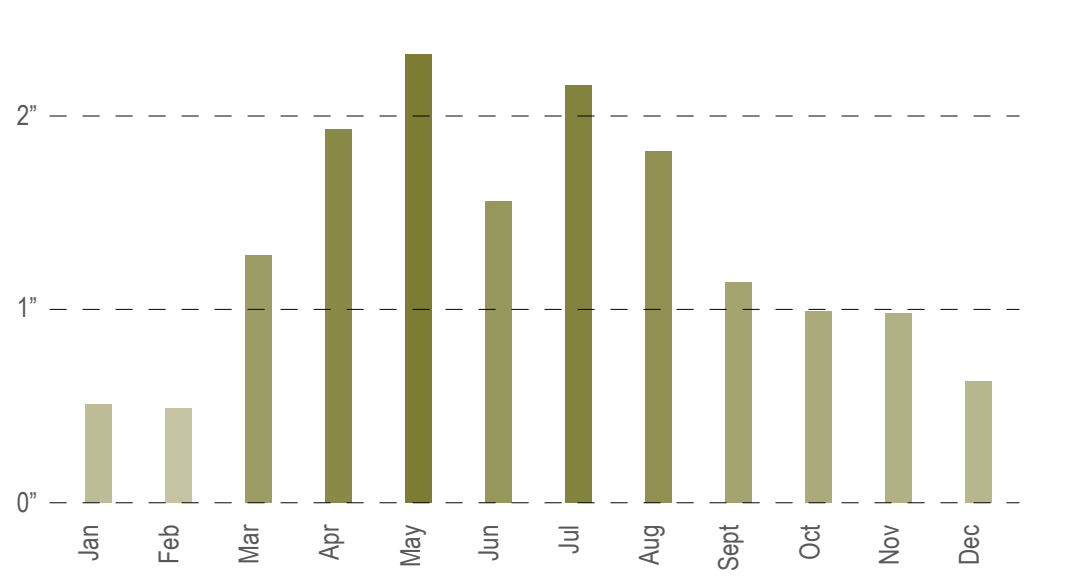

Figure 01.3-A: Denver, Colorado Monthly Average Temperature



NOTE: Source: <http://www.denver.org/metro/weather>

Figure 01.3-B: Denver, Colorado Monthly Average Precipitation



NOTE: Source: <http://www.denver.org/metro/weather>

## 02.1 TEAM PROFILE

**Matthew Tokarik** *(Team Lead)* is a Master of Applied Science (in Building Science) student at Ryerson University with a civil engineering degree. He is a Certified Passive House Consultant and an active member in the Passive House community.

**Patrick Andres** is a second year Master of Applied Science (in Building Science) student at Ryerson University with an undergraduate degree in environmental engineering. Patrick is a certified Passive House Consultant. His research focus is on assessing the life cycle carbon impact of constructing homes to the Passive House Standard.

**Matt Carlsson** is a first year master of Applied Science (in Building Science) student at Ryerson University. He is a professional mechanical engineer with a background in manufacturing. Matt's particular interests lay in building energy simulation.

**Antonio Cunha** is a Master of Architecture student at Ryerson University with an undergraduate degree in Architectural Science. He has professional experience in design and construction of single family residential as well as large scale commercial developments. His research is focussed on file-to-factory methods of design and construction toward building performance optimization.

**Mark Grimsrud** is a second year Master of Architecture student at Ryerson University with an undergraduate degree in architecture. Mark is a founding member of the Emerging Green Builders CAGBC Vancouver chapter. He has worked on many custom sustainable homes prior to pursuing his master's degree.

**Denver Jermyn** is a second year Master of Applied Science (in Building Science) student at Ryerson University. Denver's undergraduate degree is in biological engineering and he has professional experience as an engineering consultant focussing on sustainable construction.

**Moe Otsubo** is a second year Master of Applied Science (in Building Science) student at Ryerson University double-majoring in architectural and environmental studies. Moe's interests lay in daylighting and high performance homes. Her research investigates the gap between actual and simulated energy consumption of high performance homes.

**Matthew Suriano** is a Master of Architecture student at Ryerson University with an undergraduate degree in Architectural Science. He has imparted his design and technical skills in practice among a wide array of projects. Matthew is interested in exploring digital technologies and processes in relation to the architectural experience.

**Filip Tisler** is a Master of Architecture student at Ryerson University with an undergraduate degree in Architectural Science. He has extensive experience in engineering document production, digital modeling and fabrication technologies. Filip's research interests are centered upon computation of material properties and digital design tools.

**German Vaisman** is a Master of Applied Science (in Building Science) student at Ryerson University with a degree in architecture from Argentina. German contributed to the development of renewable energy strategies at both the building and community scale in addition to developing the proposed integrated photovoltaic technologies.

**Faculty Advisors:** Dr. Mark Gorgolewski, Dr. Paul Floerke, Prof. Vincent Hui, Dr. Russell Richman, Prof. Vera Straka (Ryerson University's Department of Architectural Science)

## 02.2 ACADEMIC INSTITUTION PROFILE

### Ryerson University

Over the last 20 years Ryerson University in Toronto has emerged as a significant centre for research activity in the areas of Energy, Sustainability and the Environment. Work is focusing on green technologies that can help Canada meet its climate change goals, reduce energy costs for families and Canadian industries (making them more competitive), and grow globally competitive companies. Ryerson University is home to a host of faculty researchers in technology, management, social sciences, architecture and interior design, focusing on elements of the green economy and technology.

Of particular relevance here is Ryerson's Centre for Urban Energy (CUE) which is a focal point for green tech research that links experts from industry, academia and the public sector to find innovative, next-generation solutions to keep cities powered, now and for many years to come. CUE is a multi-disciplinary facility equipped with high-tech labs designed for conducting basic and applied research as well as demonstrating new technologies. Several of the faculty advisors for this project proposal are involved in projects through the CUE. Also Ryerson has recently established a Design Fabrication Zone (DFZ), which is an innovation incubator working with industry and public organizations to promote new design and fabrication technologies and strategies.

## 02.3 EEBA HOUSES THAT WORK CERTIFICATION

Upon the submission of this report, faculty team lead Professor Mark Gorgolewski verifies that all team participants have completed and passed all courses of the Advanced Green Builder Certification Program, presented in partnership with the EEBA (Energy and Environmental Building Alliance).

### The Department of Architectural Science (DAS)

This project has been undertaken by students and faculty from Ryerson University's Department of Architectural Science, which is the most recent professionally accredited architecture program in Canada. It is also the only undergraduate program in North America that fosters specializations of architecture, building science and project management under one roof, which is particularly relevant for this project as it enabled students to explore the architectural, technical and practical realization issues of this project. The Department consists of twenty-six full time faculty members who undertake both teaching and scholarly, research and creative activities. A considerable proportion of this is in the area of building science and building performance assessment where faculty have been particularly successful with research funding.

## 03.1 ARCHITECTURAL & PERFORMANCE GOALS

The Harvest Home aims to become a prototype for the future of North American residential construction. The 1,275 square foot, two and one-half storey home assumes a simplistic and wholistic approach to architectural design. The residence is a direct derivative of its natural context, maximizing passive sustainable strategies to optimize construction cost, building performance and occupant comfort. Active technologies are employed solely to supplement the structure's performance in pursuit of becoming a nearly net-zero energy home.

The Harvest Home is designed to meet Passive House Institute of United States (PHIUS) certification. Through thoughtful interior spatial organization coupled with optimized glazing distribution, the Harvest Home boasts ample daylight penetration throughout its modest sized floor plate. A central gallery stair provides an interconnected floor space conducive to passive ventilation while allowing for Southern daylight exposure and seasonal heat gains. Pergolas located at the South terrace and rear yard further mediate daylight penetration based upon incident solar angles throughout both heating and cooling seasons.

The ultimate goal of the Harvest Home proposal is to become an affordable high-performance, net-zero energy ready residence. In pursuit of this goal, the home has incorporated resource efficient appliances and fixtures to reduce energy consumption and operation costs. The proposal also provides ample roof surface area for the future accommodation of photovoltaic panels in an effort to offset nearly all of the home's energy consumption.



CLIMATE



DAYLIGHTING + SOLAR HEAT GAIN



RAIN WATER COLLECTION



INDOOR/OUTDOOR LIVING



MATERIAL SELECTION



BUILDABILITY



LOGISTICS



URBAN AGRICULTURE



MINIMIZED SERVICING



RESOURCE EFFICIENCY

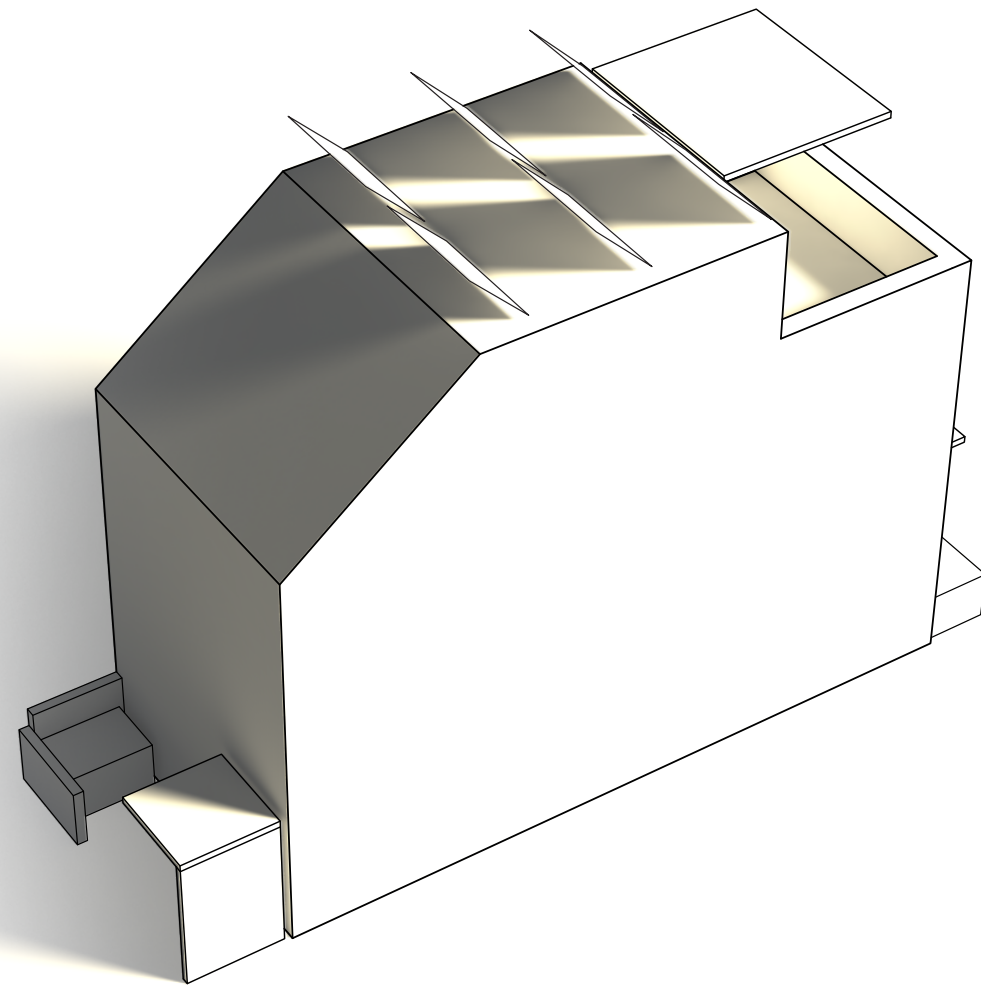

Proposed Harvest Home Massing

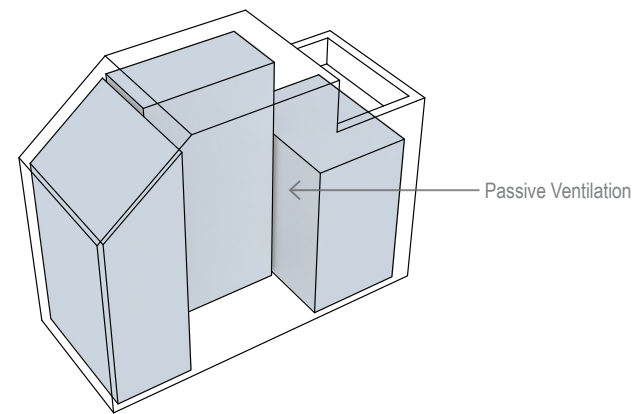

Central Stair

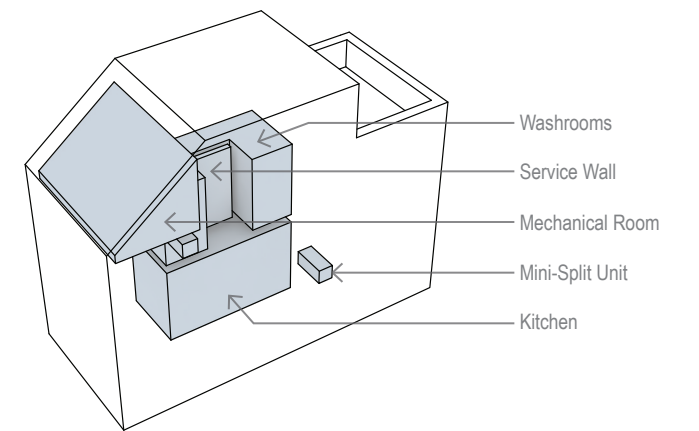

MEP Arrangement

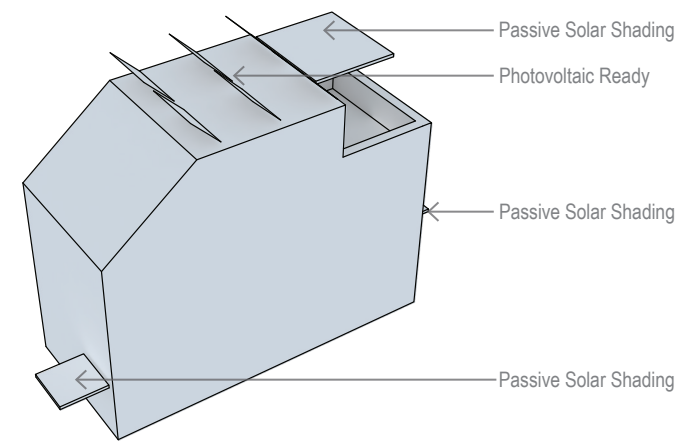

Solar Shading & PV Orientation

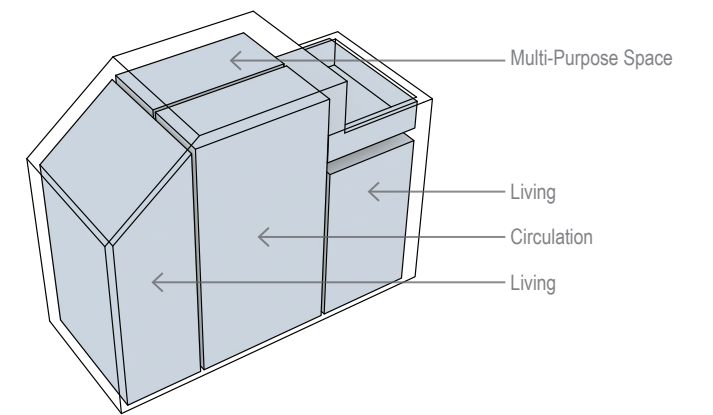

Interior Program Massing

# 03.2 SITE PLAN



- Fire Station
- Urban Garden
- Place of Worship
- Restaurant & Bar
- Educational Facilities
- Gym & Fitness Center
- Arts & Entertainment Complex
- Employment and Office Centers
- Supermarket & Convenience Store

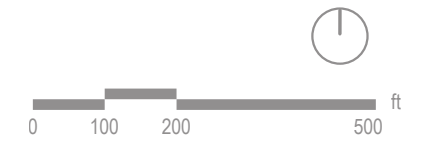
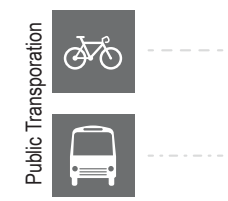

Existing Site Plan



Proposed Site Plan

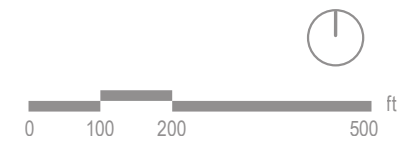

# 03.3 FLOOR PLANS

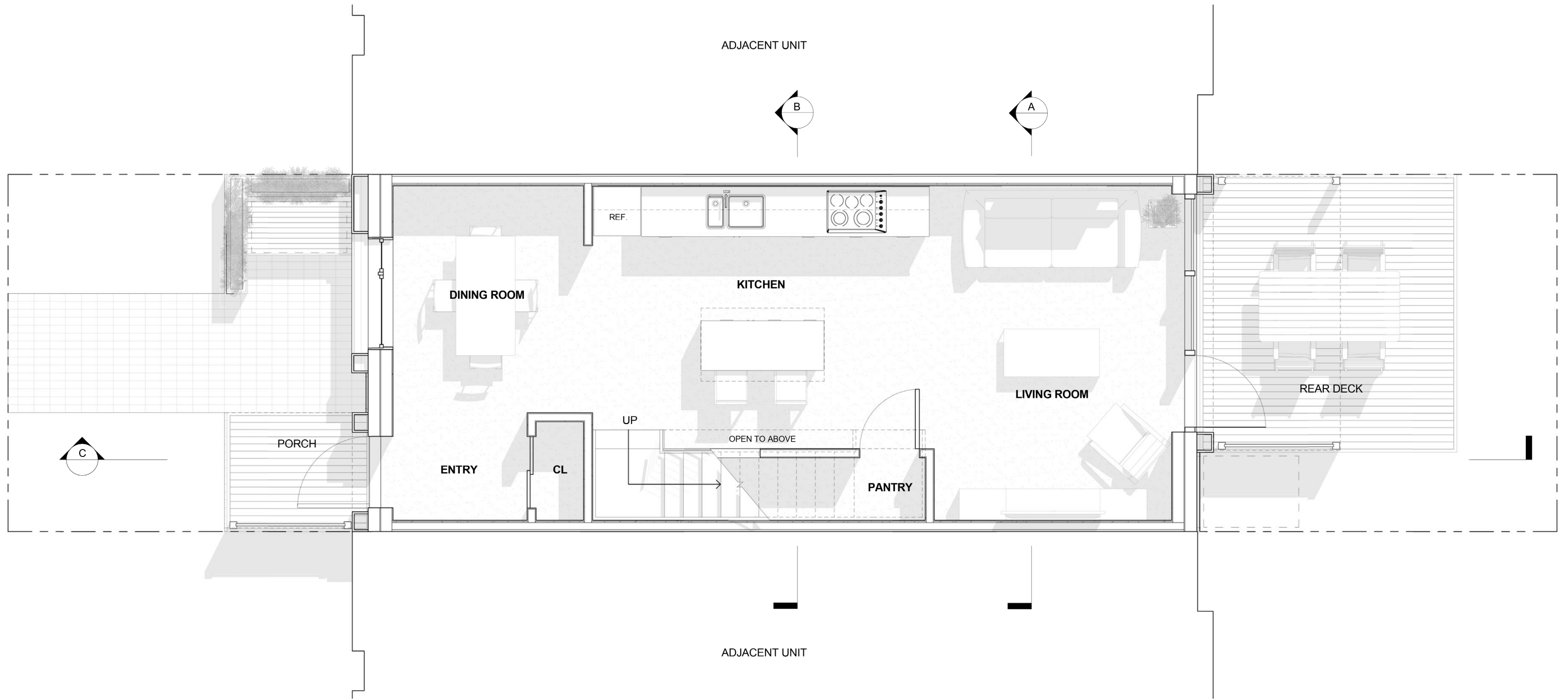

Floor Plan - Level One  
Scale: 1/4" = 1'-0" 

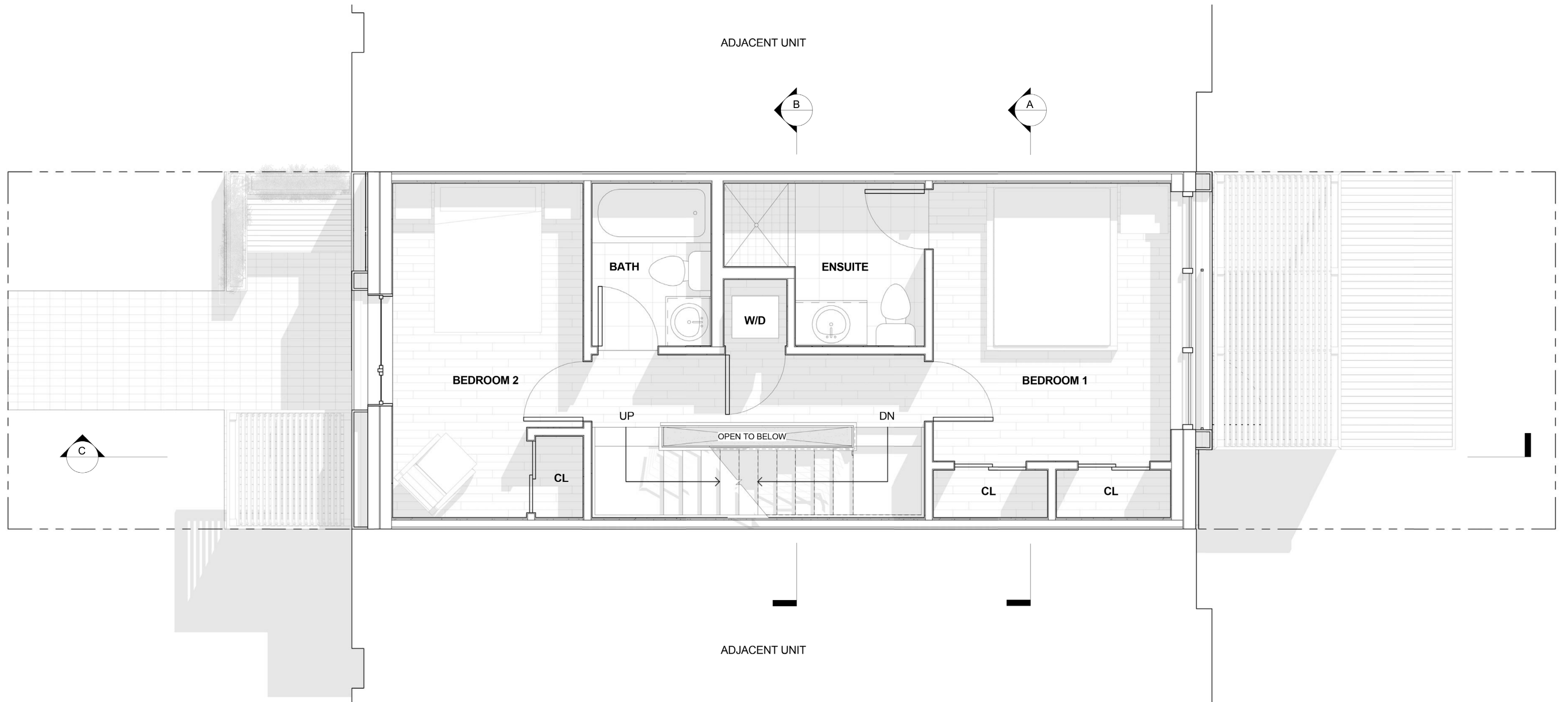

Floor Plan - Level Two  
 Scale: 1/4" = 1'-0"



# 03.3 FLOOR PLANS

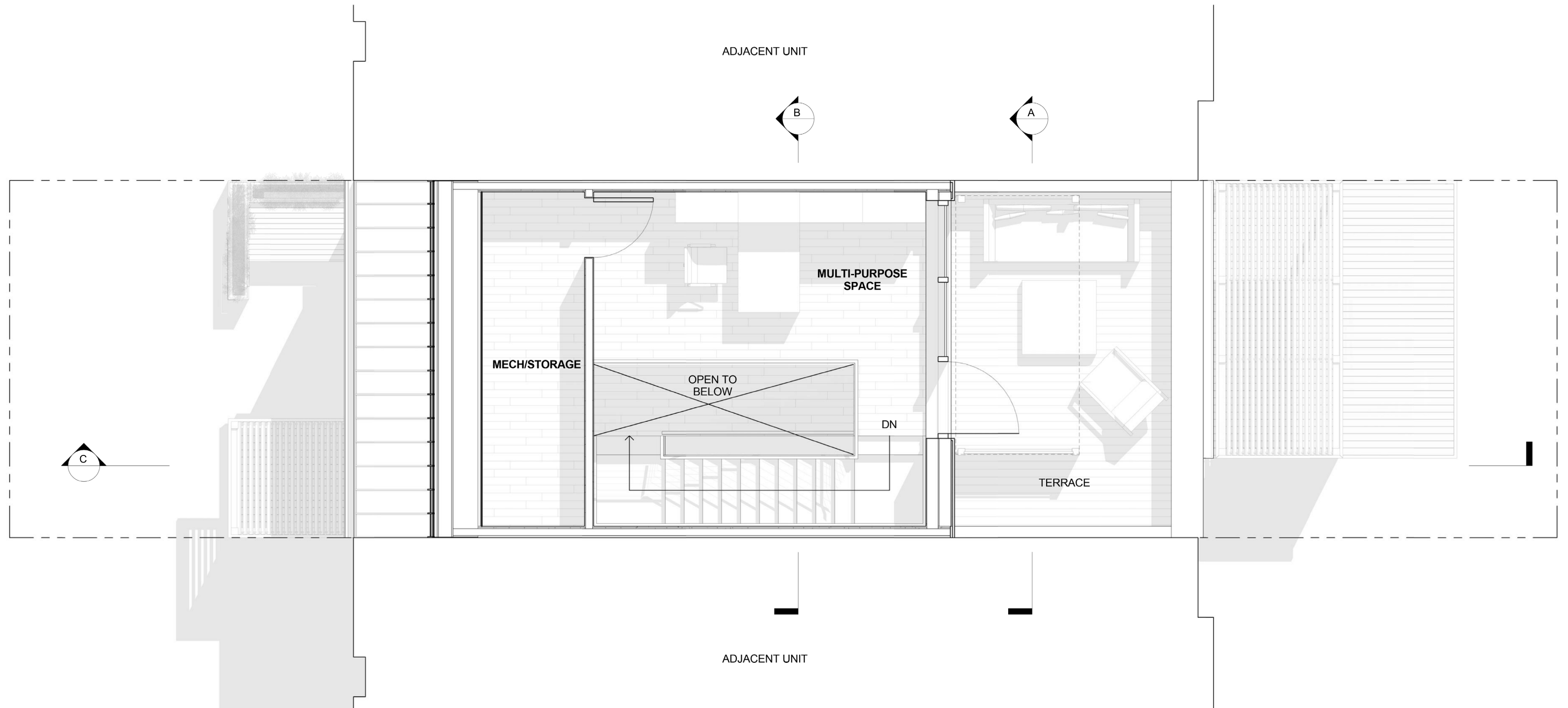

Floor Plan - Level Three  
Scale: 1/4" = 1'-0"



# 03.4 BUILDING ELEVATIONS

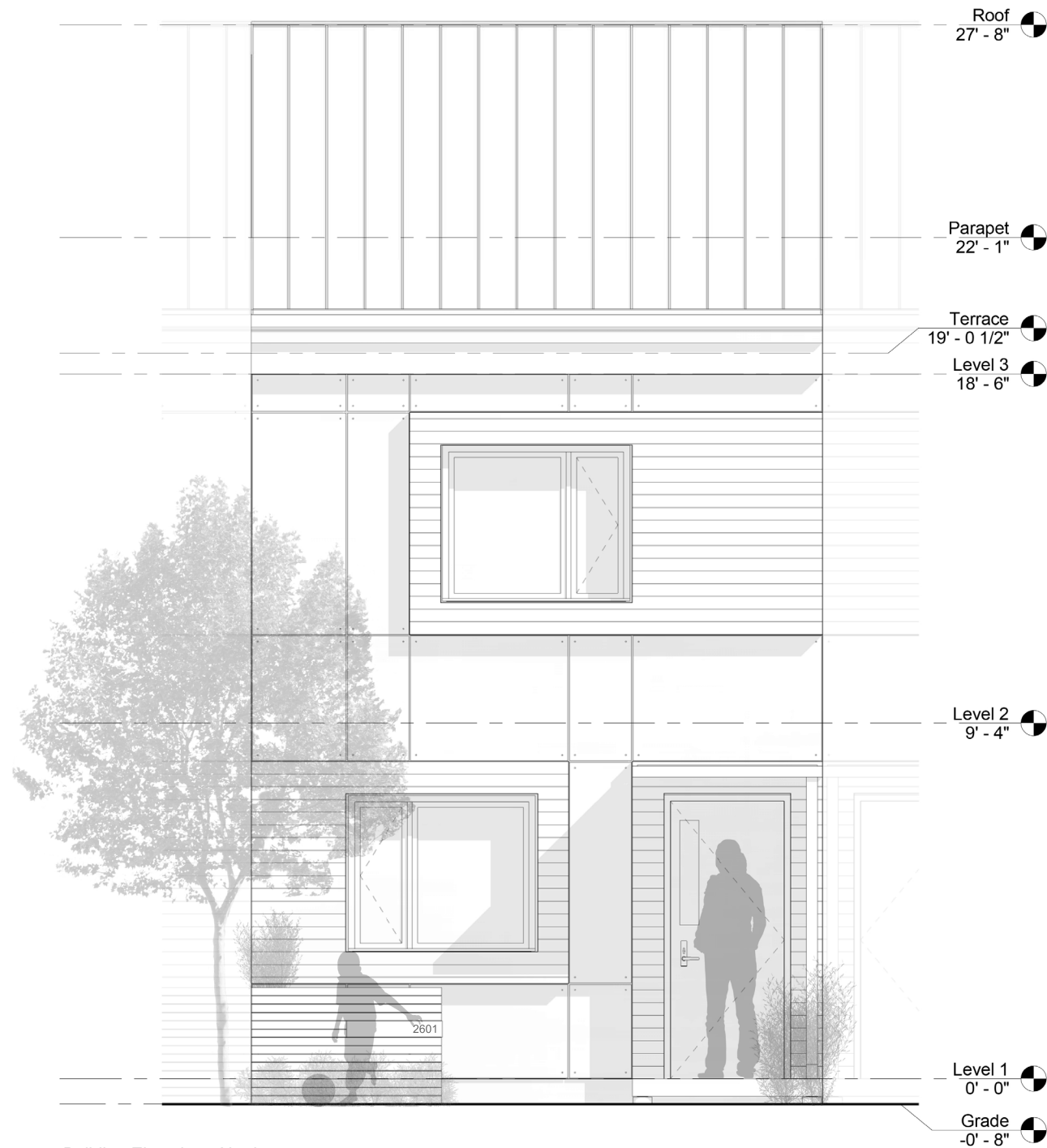

Building Elevation - North  
Scale: 1/4" = 1'-0"

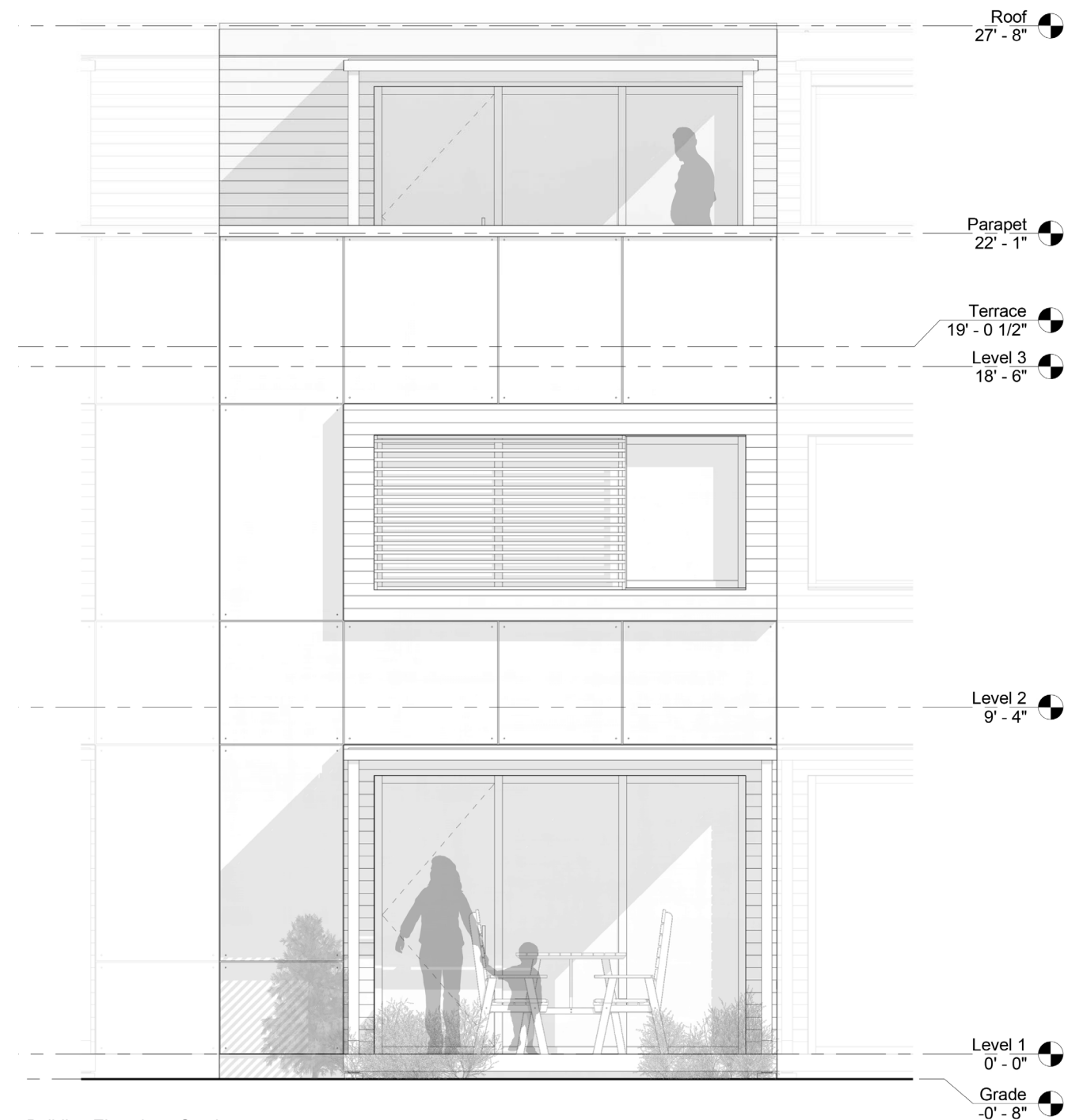

Building Elevation - South  
Scale: 1/4" = 1'-0"

# 03.4 BUILDING ELEVATIONS



Rowhouse Elevation - North  
Scale: 1/8" = 1'-0"

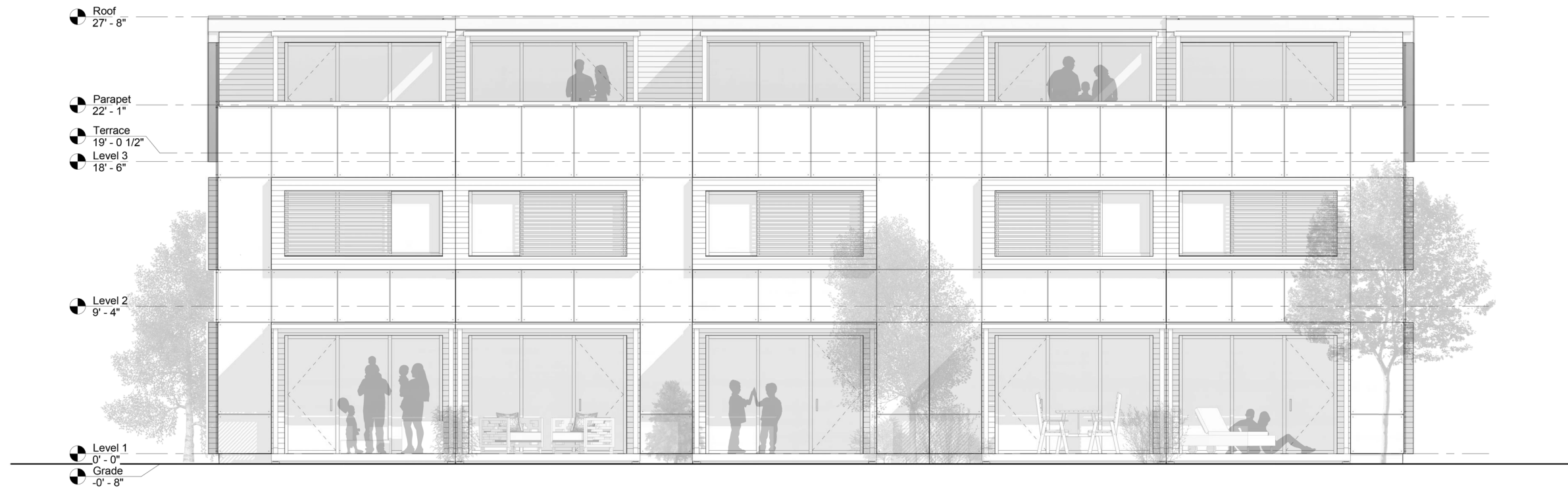

Rowhouse Elevation - South  
 Scale: 1/8" = 1'-0"

# 03.5 BUILDING SECTIONS

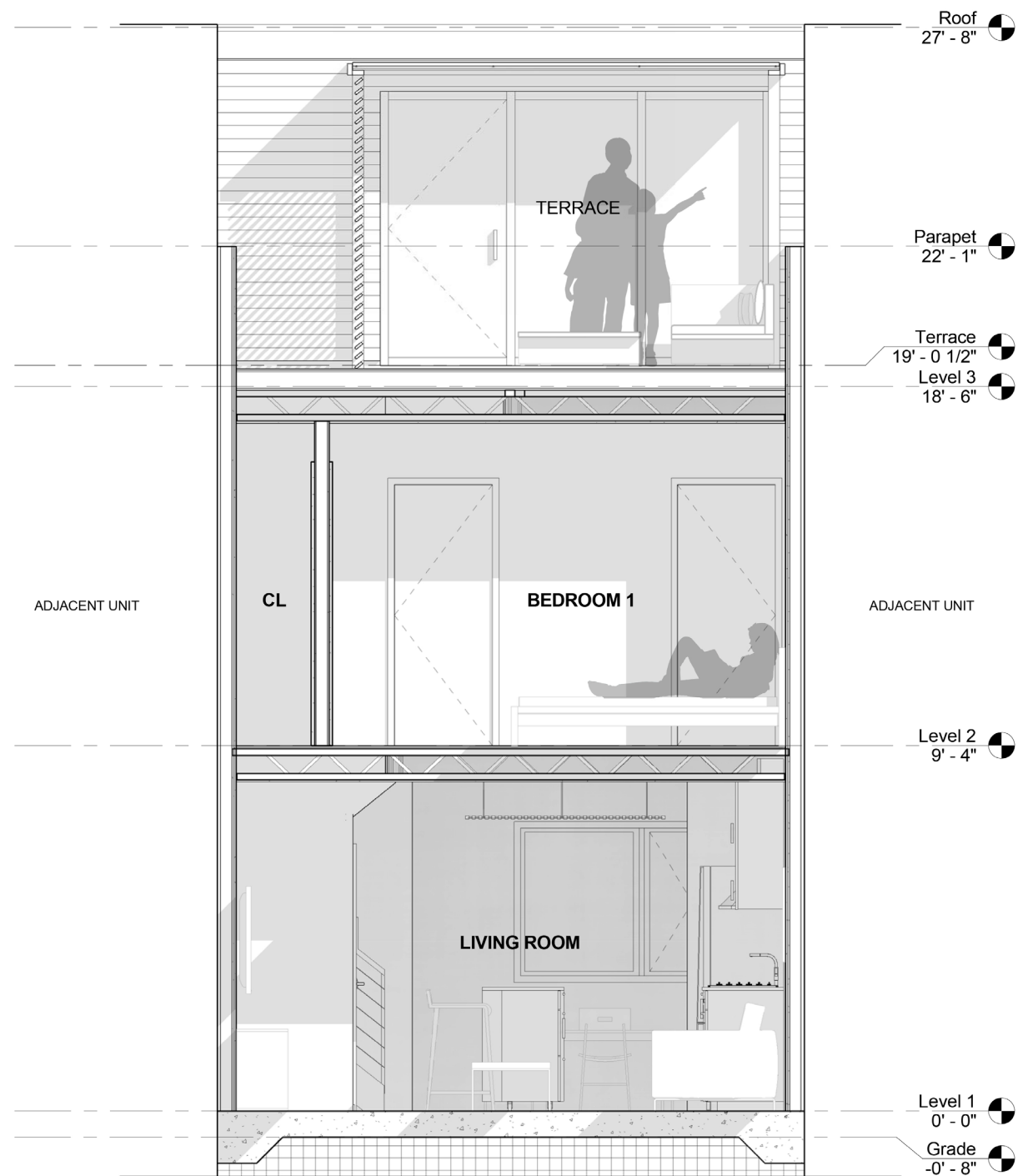

Building Section - A  
Scale: 1/4" = 1'-0"

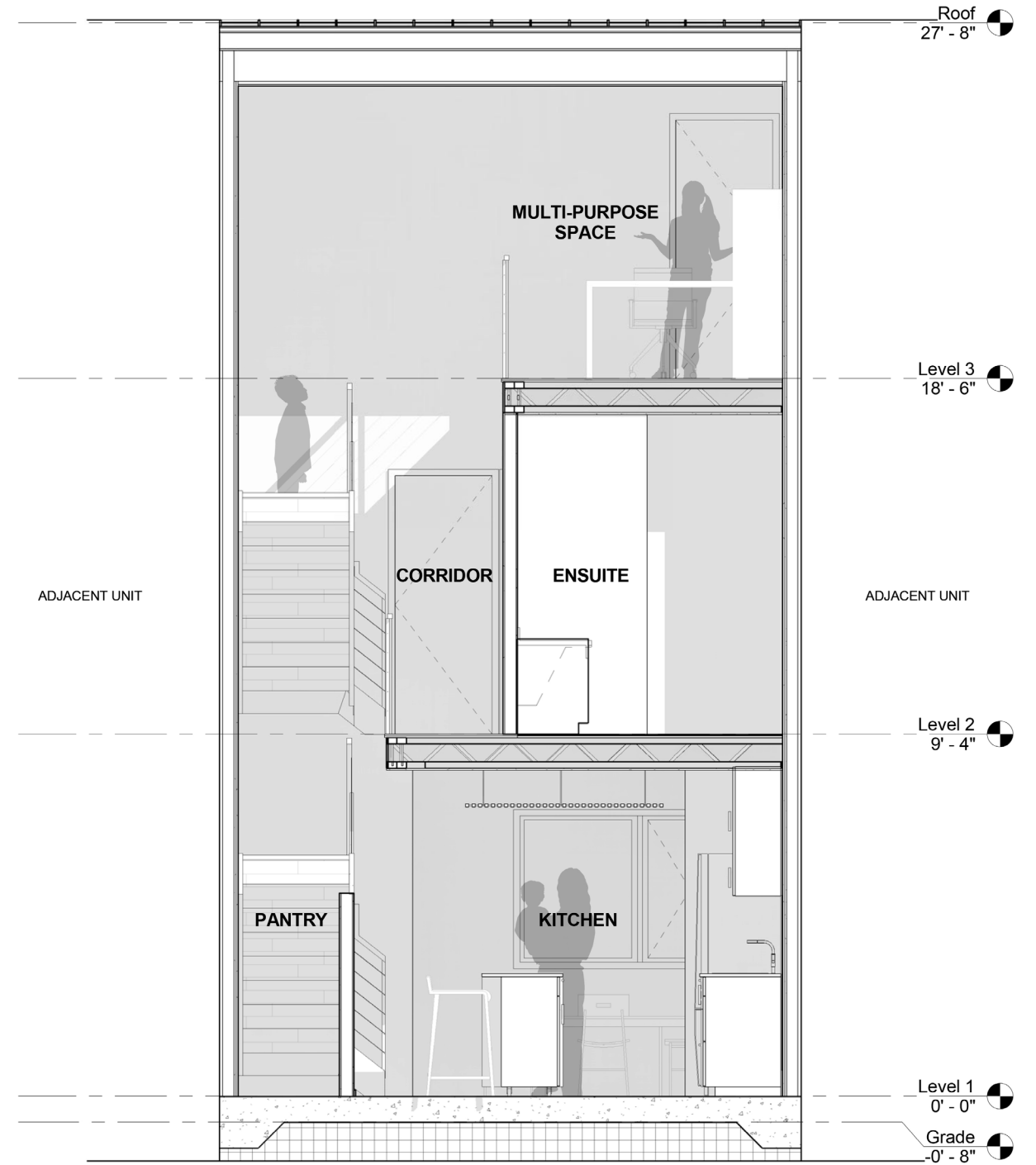

Building Section - B  
Scale: 1/4" = 1'-0"



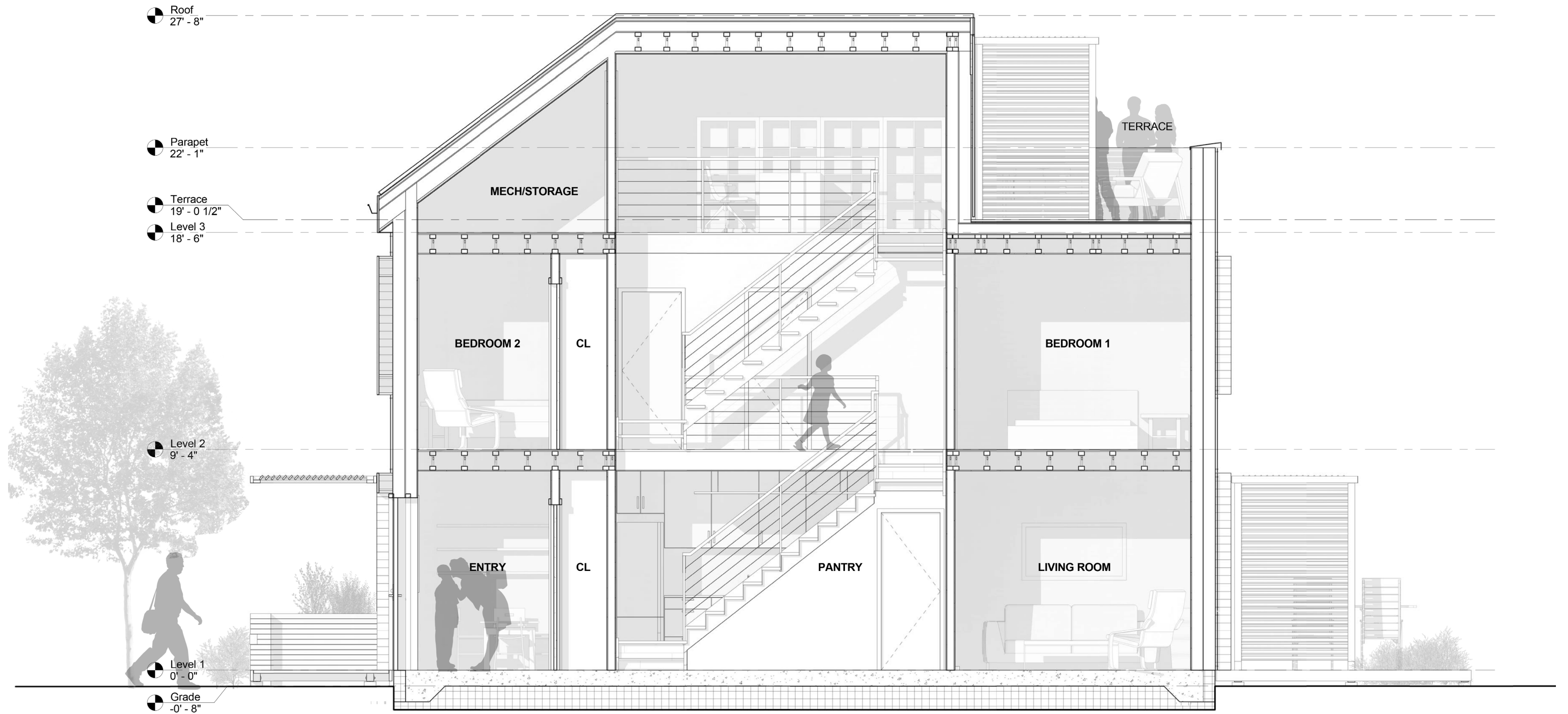

Building Section - C  
Scale: 1/4" = 1'-0"



Frontage at Lawrence Street



Kitchen View to Rear



Second Level Gallery Stair



Third Level South Terrace

## 03.7 PASSIVE HOUSE ENERGY MODELING

Energy modeling of the Harvest Home was primarily conducted using WUFI Passive, an advanced building energy simulation and Passive House verification tool specifically tailored for North American climates. WUFI Passive was used to guide the design development of the Harvest Home, enabling the iterative refinement of the thermal envelope, glazing, shading and mechanical systems, eventually producing a final product that satisfies the DOE Challenge Home and Passive House Standard energy efficiency and cost objectives.

Simulation of the Harvest Home's performance was conducted for two build scenarios. Scenario 1 treats the Harvest Home as a one-off construction for incorporation into a row house development comprised of five unique proposals, whereas Scenario 2 assesses the Harvest Home design as an integrated five-unit development.

### Scenario 1:

In order to produce realistic results for Scenario 1, several assumptions are made regarding the adjoining row house units, including; that neighboring units:

- do not shade the glazing of the Harvest Home;
- have thermal bridge free foundations and footings, and;
- are only two storeys (20 feet) in height.

A consequence of the final assumption is that the third storey of the Harvest Home has two additional exposed walls contributing to additional heat loss. Envelope assemblies were built in WUFI Passive and glazing specifications obtained from the manufacturer's passive

Table 03.7-A: Envelope Component R-Values

Component	R-value*	U-value
	hr-ft <sup>2</sup> -°F/Btu	Btu/hr-ft <sup>2</sup> -°F
Floor Slab	47.6	0.021
Party Wall	12.8	0.078
Exterior Wall	43.5	0.023
Sloped Roof	55.6	0.018
Flat Roof (Terrace)	55.6	0.018
Entry Door	11.0	0.091

NOTE: Determined by WUFI Passive

Table 03.7-B: Window R-Values, U-Values and Solar Heat Gain Coefficients

Window	Model	R-value*	Total U-value*	SHGC**
		hr-ft <sup>2</sup> -°F/Btu	Btu/hr-ft <sup>2</sup> -°F	
South Level 1 (Door)	Alpen 725	6.41	0.16	0.56
South Level 1 (Center)	Alpen 725	6.41	0.16	0.56
South Level 1 (Left)	Alpen 725	6.41	0.16	0.56
South Level 2 (Left)	Alpen 725	6.10	0.16	0.56
South Level 2 (Center)	Alpen 725	6.10	0.16	0.56
South Level 2 (Right)	Alpen 725	6.10	0.16	0.56
South Level 3 (Left)	Alpen 725	6.41	0.16	0.56
South Level 3 (Center)	Alpen 725	6.41	0.16	0.56
South Level 3 (Right)	Alpen 725	6.41	0.16	0.56
North Level 1 (Left)	Alpen 525-S	5.32	0.19	0.37
North Level 1 (Right)	Alpen 525-S	5.32	0.19	0.37
North Level 1 (Door Panel)	Alpen 725	3.57	0.28	0.37
North Level 2 (Left)	Alpen 525-S	6.25	0.16	0.37
North Level 2 (Right)	Alpen 525-S	6.25	0.16	0.37

NOTES: \* Determined by WUFI Passive  
\*\* Based on Manufacturer Specifications

house certifications were entered into the model. Envelope and window parameters calculated using WUFI Passive are summarized in Tables 03.7-A and 03.6-7, respectively. Additional input data and associated calculations are attached in Appendix 3. A summary of simulated Scenario 1 source energy results compared to the Passive House Standard criteria are provided in Table 03.6-C.

### Scenario 2

Scenario 2 assumes a uniform row house development, as indicated in section 03.4: Building Elevations. The central three units share third storey party walls with neighboring units, thus reducing heat loss areas. The energy performance of Scenario 2 is simulated by running three separate WUFI Passive models, one each for East and West end units and one representing the three mid-row units. Results are then averaged over the five units to verify compliance with the Passive House standard and are summarized in Table 03.7-D. For the full length WUFI Passive reports, refer to Appendix 3.

Considering WUFI Passive generates results representing the source energy intensity for comparison with the Passive House Standard criteria, the data is converted to source energy for comparison with the results generated using REM/Rate. Predicted annual heating/cooling demands and loads are calculated from WUFI Passive simulation results by multiplying the specific energy use in Tables 03.7-C and D by the treated floor area. The aggregate energy consumption representing total on-site energy consumed is calculated by multiplying the primary energy demand from Tables 03.7-C and D by the treated floor area and dividing by the primary energy factor. Results of this calculation are provided in table 03.7-E.

Table 03.7-C: Case 1 Source Energy Intensity Results for Passive House Verification\*

	Heat Demand	Cooling Demand	Peak Heating Load**	Peak Cooling Load	Primary Energy Demand
	kBTU/ft <sup>2</sup> -yr	kBTU/ft <sup>2</sup> -yr	BTU/hr-ft <sup>2</sup>	BTU/hr-ft <sup>2</sup>	kBTU/ft <sup>2</sup> -yr
Passive House Standard	4.75	4.75	3.17	3.17	38.0
Single Unit Harvest Home	2.90	1.70	4.00	1.40	38.6

NOTES: \* Source Energy Intensity refers to the amount of primary energy consumed per ft<sup>2</sup> of treated floor area (TFA=893 ft<sup>2</sup>)  
 \*\* Meeting Peak Heating Load is optional (must only be met if Annual Heat Demand cannot be met)  
 \*\*\* All results obtained from WUFI Passive energy model for Passive House Verification

Table 03.7-D: Case 2 Source Energy Intensity Results for Passive House Verification\*

	Heat Demand	Cooling Demand	Peak Heating Load**	Peak Cooling Load	Primary Energy Demand
	kBTU/ft <sup>2</sup> -yr	kBTU/ft <sup>2</sup> -yr	BTU/hr-ft <sup>2</sup>	BTU/hr-ft <sup>2</sup>	kBTU/ft <sup>2</sup> -yr
Passive House Standard	4.75	4.75	3.17	3.17	38
South West End Unit	3.5	1.7	3.9	1.2	39.5
Middle Units (X3)	1.6	1.8	3.6	1.6	36.6
North East End Unit	3.7	1.6	3.9	1.2	39.8
Row House Average ***	2.4	1.74	3.72	1.44	37.82

NOTES: \* Source Energy Intensity refers to the amount of primary energy consumed per ft<sup>2</sup> of treated floor area (TFA=893 ft<sup>2</sup>)  
 \*\* Meeting Peak Heating Load is optional (must only be met if Annual Heat Demand cannot be met)  
 \*\*\* All results obtained from WUFI Passive energy model for Passive House Verification

Table 03.7-E: WUFI Passive Annual Energy Consumption Results

	Heat Demand	Cooling Demand	Peak Heating Load	Peak Cooling Load	Total Energy Cons.*
	kBTU/yr	kBTU/yr	BTU/hr	BTU/hr	kBTU/yr
Single Unit Harvest Home	2,612	1,520	3,544	1,271	12,586
Row House Average	2,143	1,554	3,322	1,286	12,509

NOTE: \* Total Energy Consumption value represents site energy consumption, excluding on-site renewable energy generation

## 03.8 REM/RATE MODEL & RESNET HERS RATING RESULTS

A version of REM/Rate building energy simulation software was obtained from Architectural Energy Corporation and is used to calculate annual energy costs and obtain RESNET HERS ratings for the Harvest Home. Scenario 1 was the only case modeled, considering it is representative of what is likely to be constructed through the Denver Superefficient Homes Challenge. Also, the results of WUFI Passive modelling in Tables 03.7-C and 03.7-D indicate that Scenario 1 consumes more energy than the row house average (Scenario 2).

Identical opaque and transparent envelope parameters used in the WUFI Passive simulation (Tables 03.7-A and B) were entered into the REM/Rate model. Entire building annual energy demands, peak loads and total energy consumption determined using REM/Rate are shown in Table 03.8-A. For the full length REM/Rate Report, refer to Appendix 3.

A comparison of results generated using WUFI Passive in Table 03.7-E and REM/Rate in Table 03.8-A indicate that REM/Rate produces results with lower annual heating and cooling demand, while results for peak heating/cooling loads and total energy consumption are significantly higher. These results are solely used for verification with the respective program certification criteria. Actual load calculations used for equipment sizing are conducted according to the ASHRAE procedure as detailed in Section 12: Additional Documentation.

HERS ratings are generated for two scenarios. Scenario 1 represents the Harvest Home with on-site renewable energy generation, while Scenario 2 utilizes traditional energy sources. The Harvest Home is designed to be solar photovoltaic ready, therefore Scenario 1 is modelled including a 2.4 kW photovoltaic array, resulting in a HERS

rating of 20. The REM/Rate model not including solar photovoltaic results in a HERS rating of 40. According to the Passive House Institute U.S., a typical existing certified project features a rating of between 30 and 45.

### Annual Energy Costs

Annual energy costs for Scenario 1 are determined from the WUFI Passive and REM/Rate modeling results as summarized in Table 03.8-B. The annual energy cost calculated using REM/Rate is 41% of the average Colorado household. The cost calculated using REM/Rate is 150% of the cost predicted by WUFI Passive. Considering the annual energy cost predicted by REM/Rate is more conservative than the WUFI Passive result, it is used in the metrics in Section 04.2: Cash Flow Analysis.

Table 03.8-A: REM/Rate Annual Energy Consumption Results

	Heat Demand	Cooling Demand	Peak Heating Load**	Peak Cooling Load**	Total Energy Cons.*
	kBTU/yr	kBTU/yr	BTU/hr	BTU/hr	kBTU/yr
Single Unit Harvest Home	700	1300	6300	6700	23600

NOTES: \* Total Energy Consumption value represents site energy consumption, excluding on-site renewable energy generation  
\*\* Peak Heating & Cooling Loads converted from REM/Rate output of kBTU/hr to BTU/hr

Table 03.8-B: Energy Cost Consumption of Harvest Home to Average Colorado Household

	Energy Consumption	Energy Consumption	Electricity Cost***	Energy Cost
	kBTU/year	kWh/year	\$/kWh	\$/year
Average Colorado Household*	102,000	29,893	0.1144	\$1,551
Harvest Home (REM/Rate Predicted Results)**	23,600	6,916	0.0914	\$632
Harvest Home (WUFI Passive Predicted Results)	12,586	3,688	0.1144	\$422

NOTES: \* All energy consumed in average Colorado household, including electricity. [http://www.eia.gov/consumption/residential/reports/2009/state\\_briefs/pdf/co.pdf](http://www.eia.gov/consumption/residential/reports/2009/state_briefs/pdf/co.pdf)  
\*\* REM/Rate annual energy cost derived from simulation output and price per kWh is back-calculated from annual energy cost and annual energy consumption  
\*\*\* For WUFI Passive and Average Colorado household retail price of electricity to residential consumers for 2013 (11.44 c/kWh) [http://www.eia.gov/electricity/monthly/epm\\_table\\_grapher.cfm?t=epmt\\_5\\_6\\_a](http://www.eia.gov/electricity/monthly/epm_table_grapher.cfm?t=epmt_5_6_a)



### 03.9 THE INTEGRATED DESIGN PROCESS

The multi-disciplinary Harvest Home team features Masters of Architecture Students, Master of Building Science Students, support faculty and a series of external consultants. Acting as a single design entity, architecture and building science student groups work in tandem through an iterative process of design, simulation, analysis and revision. A multi-disciplinary faculty support team works closely with the larger student group on both a formal and informal basis, providing critical guidance and feedback on aesthetics, constructability, performance and costing among many other items. The team also seeks guidance from external consultants regarding items such as Passive House practices, material selection and life cycle costing.

The Harvest Home employs an Autodesk Revit BIM model in conjunction with Rhinoceros 3D in the design process allowing for virtually seamless coordination between team members on a wide variety of software platforms. This process has allowed the team to rapidly conduct studies, simulations and make revisions to the design to optimize constructability, performance and interior comfort.

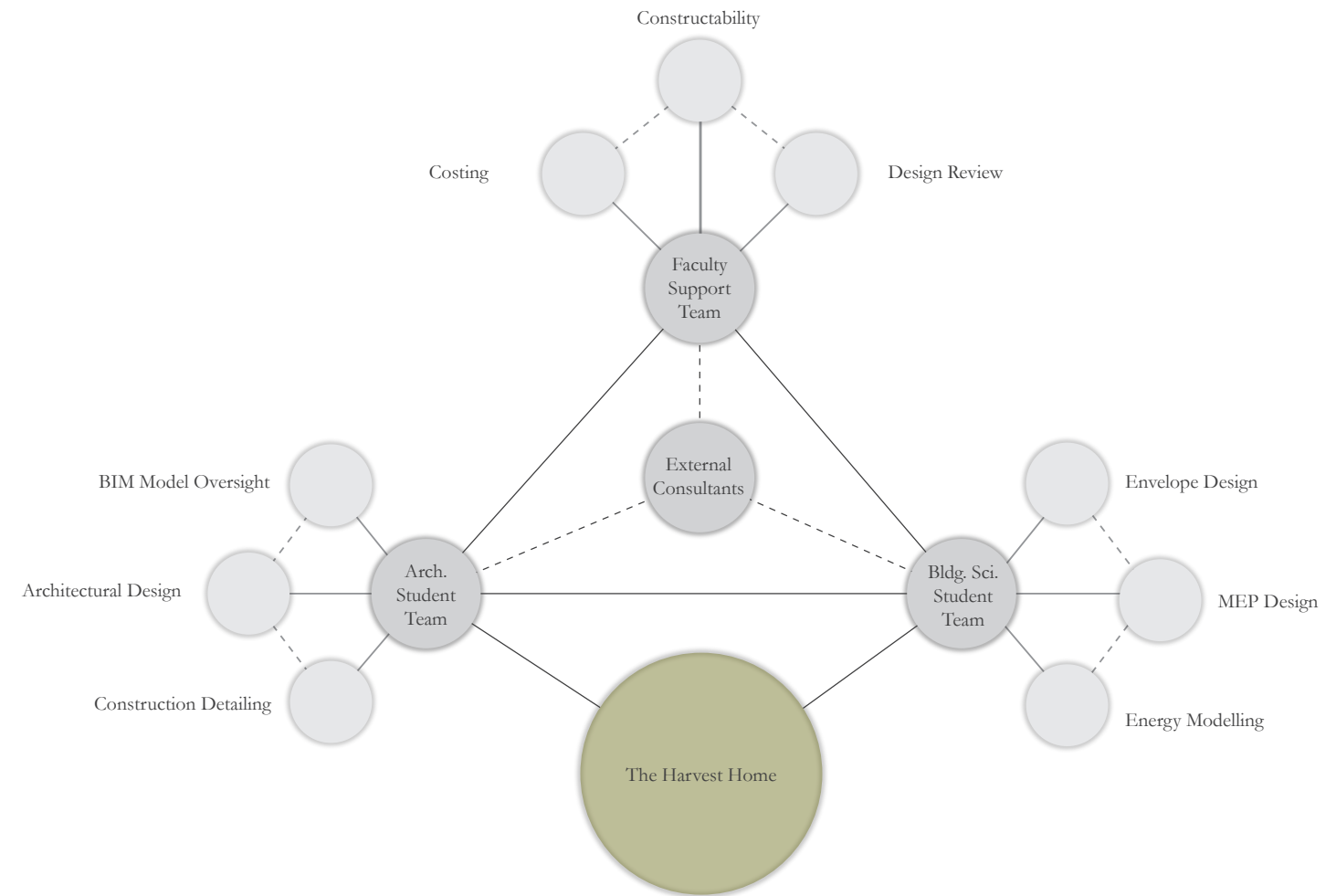

Design Team Relationship Web

## 03.9 THE INTEGRATED DESIGN PROCESS

The design of the Harvest Home commenced in late September, 2013. Over the following six months, the design team has conducted formal coordination meetings and charrettes on a regular basis. Working within the guidelines of the Denver Super Efficient Housing Challenge, the team has capitalized on the opportunity to gain feedback from the community, the developer and the Rocky Mountain Institute through interim design reviews and consultation events.



## 04.0 FINANCIAL ANALYSIS

### Summary:

The following section outlines the financial analysis undertaken with regard to the Harvest Home proposal. The Harvest Home is designed to be cost effective from a buyer's perspective taking into consideration long-term capital, operation, and maintenance costs. The Harvest Home is designed under the parameters of the Denver Superefficient Housing Challenge which dictate the total construction cost, construction cost per square foot, and approximate area of the house. The financial requirements as per the Denver Super Efficient Housing Challenge are as follows:

Target Construction Cost: \$180,000

Target Cost per Square Foot: \$150

Given these financial requirements, an analysis of the construction costs, affordability of the home, and cash flow analysis is conducted based on the DOE Challenge Home guidelines.

### Assumptions:

- a. Construction cost data sourced from Waier, Babbitt, Balboni & Charest (2012) and Waier, Babbitt, and Charest (2012).
- b. Where applicable, construction cost data is based on retail cost.
- c. Electrical, plumbing & underground utility construction costs sourced from Taylor (2011).
- d. Utility costs are taken at \$632/year based on the HERS rating although some modeling programs calculate utility costs as low as \$422/year.
- e. Only major maintenance items are considered in the analysis as it is assumed that smaller maintenance items (eg. repainting) would not negatively affect the cash flow.
- f. Cladding, roofing, and windows are not assumed to require replacement in the mortgage period as high durability components are selected.
- g. High performance features are limited to building envelope, HVAC, and appliances.
- h. An aggregate inflation value is used for the utility cost increase over the thirty year mortgage period. The aggregate inflation value is calculated as the difference between the utility cost increase and the inflation rate.
- i. Inflation rates for the sensitivity analysis are assumed based on historic high and low values for Colorado from 1991 to 2013 (Colorado Department of Local Affairs, 2014).
- j. Utility cost increases for the sensitivity analysis are assumed based on the 2012-2013 electricity cost increase of 8.5% for Denver-Boulder-Greeley. 8.5% is taken to be a mid-range value for utility cost increase.

# 04.1 CONSTRUCTION COST ESTIMATE

To derive the construction cost estimate, the Harvest Home is divided into a series of constituent sub-categories that encompass structure, cladding, fixtures and finishes. Based on demographic, economic and local real estate analysis the design team finds that in order to achieve an affordable, yet profitable design proposal to the developer the residence’s hard construction cost is targeted at approximately \$150 per square foot. This modest construction budget does not include land value or costs associated with site works pertaining to the development of the greater site area.

The preliminary estimated construction cost including a 10% contingency is \$181,345 or approximately \$145 per square foot. Therefore the Harvest Home meets and potentially exceeds the financial constraints outlined by the Denver Super Efficient Housing Challenge with a cost well below the specified \$150 per square foot. This estimate is carried forward in the following financial analysis sections to ensure the Harvest Home meets the financial criteria of the DOE Challenge Home.

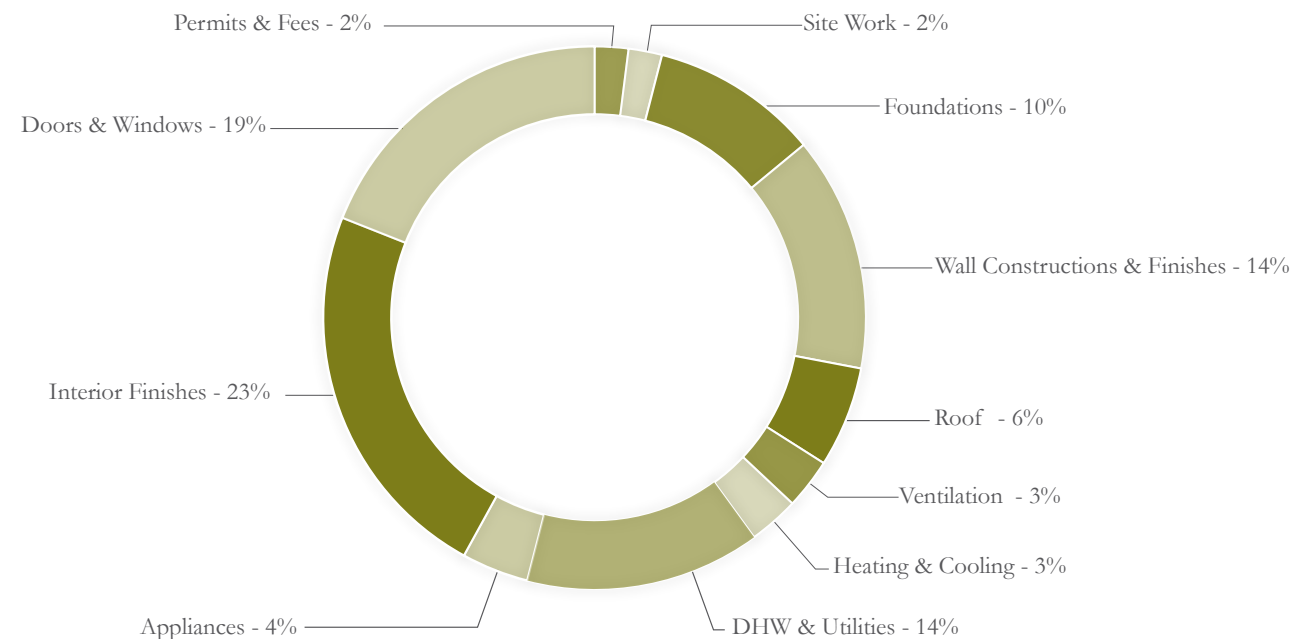

Construction Cost Breakdown by Category

Permits and Fees				
Component	Quantity	Unit	Unit Cost	Direct Cost
Building Permit		Job	0.5-2%	\$ 1,742.20
Permits and Fees		Job	0.5-2%	\$ 1,742.20
Final Interior Cleaning	1.27	1000 S.F.	\$ 92.00	\$ 116.84
			Sum	\$ 3,601.24

Site Work				
Component	Quantity	Unit	Unit Cost	Direct Cost
Surveying	0.022	Acre	\$ 590.00	\$ 12.98
Clearing and Initial Grading	0.022	Acre	\$ 1,575.00	\$ 34.65
Total Grading Allowance	108.3	S.Y.	\$ 1.61	\$ 174.36
Excavation	25.86	C.Y.	\$ 17.00	\$ 439.62
Site Fill and Grading	25.86	C.Y.	\$ 3.21	\$ 83.01
Outdoor Concrete Forms	8	S.F.	\$ 9.45	\$ 75.60
Concrete Porches	205	S.F.	\$ 4.41	\$ 904.05
Planters	2	Ea.	\$ 490.00	\$ 980.00
Shading Structure	0.31	M.B.F.	\$ 2,250.00	\$ 697.50
			Sum	\$ 3,401.77

Foundations				
Component	Quantity	Unit	Unit Cost	Direct Cost
Concrete Slab on Grade	525	S.F.	\$ 4.41	\$ 2,315.25
Concrete Slab Reinforcement	4	Ton	\$ 2,125.00	\$ 8,500.00
Rigid Insulation	555	S.F.	\$ 4.98	\$ 2,763.90
Concrete Slab Air Barrier	5.25	Sq. (100 S.F.)	\$ 22.50	\$ 118.13
Float Finish - Slabs	525	S.F.	\$ 2.68	\$ 1,407.00
Anchor Bolts	52	Ea.	\$ 17.75	\$ 923.00
Expansion Joint	70	L.F.	\$ 3.77	\$ 263.90
Drainage Tile	30	L.F.	\$ 5.65	\$ 169.50
Compacted Stone	17	Ton	\$ 21.00	\$ 357.00
Sill Gaskets	100	L.F.	\$ 4.83	\$ 483.00
			Sum	\$ 17,300.68

Wall Constructions and Finishes				
Component	Quantity	Unit	Unit Cost	Direct Cost
Exterior Wall Framing	1.28	M.B.F (1000 B.F.)	\$ 1,500.00	\$ 1,920.00
Blown Cellulose (5.5")	2552	S.F.	\$ 0.75	\$ 1,914.00
Zip Board	2552	S.F.	\$ 1.09	\$ 2,781.68
Airsealing Tape	6	Ea.	\$ 103.00	\$ 618.00
Weather Barrier	810	S.F.	\$ 0.28	\$ 226.80
6" Roxul CavityRock	810	S.F.	\$ 4.58	\$ 3,709.80
Cladding Anchors	4.54	Hundred Bolts	\$ 92.00	\$ 417.68
Z-Girts	4.68	100 L.F.	\$ 277.00	\$ 1,296.36
Cladding	810	S.F.	\$ 2.74	\$ 2,219.40
Pine Beetle Cladding	190	S.F.	\$ 3.27	\$ 621.30
Window Boxes	11	Opng.	\$ 99.00	\$ 1,089.00
Flashing	118	L.F.	\$ 6.30	\$ 743.40
TJI 24" O.C.	51	Ea.	\$ 95.10	\$ 4,850.10
Partition Wall Framing	85	L.F.	\$ 12.55	\$ 1,066.75
			Sum	\$ 23,474.27

Roof				
Component	Quantity	Unit	Unit Cost	Direct Cost
Wood Furring Strips	284	L.F.	\$ 1.39	\$ 395.10
OSB	567	S.F.	\$ 1.02	\$ 580.95
Airsealing Tape	3	Ea.	\$ 103.00	\$ 309.00
TJI 24" O.C.	19	Ea.	\$ 95.10	\$ 1,806.90
12" Blown Cellulose	567	S.F.	\$ 1.73	\$ 980.68
8" Polyiso	567	S.F.	\$ 5.53	\$ 3,133.92
TPO Roofing	5.67	Sq. (100 S.F.)	\$ 155.10	\$ 879.42
Parapet	35	L.F.	\$ 1.39	\$ 48.69
Terrace Deck Finish	150	S.F.	\$ 2.12	\$ 318.66
Gutters	100	L.F.	\$ 6.15	\$ 615.00
Downspouts	60	L.F.	\$ 3.17	\$ 190.20
		Sum		<b>\$ 9,068.32</b>

Ventilation				
Component	Quantity	Unit	Unit Cost	Direct Cost
UltimateAir 200DX ERV	1	Ea.	\$ 2,061.19	\$ 2,061.19
Aluminum Prefilter Set	1	Ea.	\$ 44.89	\$ 44.89
Internal Filter "Pies"	1	Ea.	\$ 81.53	\$ 81.53
WarmFlo Duct Heater 1.0 kW	1	Ea.	\$ 501.10	\$ 501.10
Ceiling Mounting Kit	1	Ea.	\$ 64.13	\$ 64.13
6" Wall Termination Kit	1	Ea.	\$ 77.87	\$ 77.87
4" Air adjustable Plastic Vent	10	Ea.	\$ 12.83	\$ 128.30
Shipping	1	Ea.	\$ 200.00	\$ 200.00
ERV Install	8	hr	\$ 88.22	\$ 705.75
6" Trunk Duct	60	L.F.	\$ 6.72	\$ 403.26
4" Branch Duct	64	L.F.	\$ 5.45	\$ 348.93
4" Elbows	10	Ea.	\$ 5.25	\$ 52.50
4" Splitter	4	Ea.	\$ 6.25	\$ 25.00
		Sum		<b>\$ 4,694.45</b>

Heating & Cooling				
Component	Quantity	Unit	Unit Cost	Direct Cost
MXZ-2B20 Outdoor with two MSZ-GE06 Indoor	1	Ea.	\$ 2,343.39	\$ 2,343.39
Shipping (free)	1	Ea.	\$ -	\$ -
25' Minisplit Installation Kit	2	Ea.	\$ 251.95	\$ 503.90
Wall Mounting Bracket	3	Ea.	\$ 58.65	\$ 175.95
Minisplit Install	16	hr.	\$ 92.92	\$ 1,486.70
BHA-3 Heavy Duty Electric Baseboard Radiator	3	Ea.	\$ 77.40	\$ 232.20
		Sum		<b>\$ 4,742.14</b>

DHW & Utilities				
Component	Quantity	Unit	Unit Cost	Direct Cost
GE GeoSpring hybrid water heater	1	Ea.	\$ 1,299.99	\$ 1,299.99
Shipping (free)	1	Ea.	\$ -	\$ -
DHW Install & Plumbing	1	Sub. Bid	\$ 10,990.00	\$ 10,990.00
Electrical	1	Sub. Bid	\$ 8,034.00	\$ 8,034.00
Underground Utilities	1	Municipality	\$ 3,000.00	\$ 2,952.00
		Sum		<b>\$ 23,275.99</b>

Appliances				
Component	Quantity	Unit	Unit Cost	Direct Cost
Miele Cooktop	1	Ea.	\$ 1,199.00	\$ 1,199.00
Whirlpool Oven	1	Ea.	\$ 1,399.00	\$ 1,399.00
Range Hood	1	Ea.	\$ 699.00	\$ 699.00
Moffat Refrigerator	1	Ea.	\$ 899.00	\$ 899.00
Blomberg Dishwasher	1	Ea.	\$ 810.00	\$ 810.00
Blomberg Clothes Washer	1	Ea.	\$ 1,059.00	\$ 1,059.00
Blomberg Clothes Dryer	1	Ea.	\$ 669.00	\$ 669.00
		Sum		<b>\$ 6,734.00</b>

Interior Finishes				
Component	Quantity	Unit	Unit Cost	Direct Cost
Gypsum on Wall	3474	S.F.	\$ 1.48	\$ 5,126.93
Gypsum on Roof	1248	S.F.	\$ 1.61	\$ 2,006.04
Laminate Wood Flooring	1248	S.F.	\$ 6.44	\$ 8,035.87
Interior Paint Latex	3474	S.F.	\$ 0.71	\$ 2,481.83
Pot Lights	15	Ea.	\$ 84.50	\$ 1,267.50
Tube Lights	4	Ea.	\$ 75.50	\$ 302.00
Hanging Lights	3	Ea.	\$ 121.50	\$ 364.50
Decorative Lights	8	Ea.	\$ 96.00	\$ 768.00
Towel Racks	2	Ea.	\$ 39.99	\$ 79.98
Hand Towel Ring	2	Ea.	\$ 8.99	\$ 17.98
Bathroom Mirror Cabinet 2 Doors	2	Ea.	\$ 349.00	\$ 698.00
Toilet	2	Ea.	\$ 174.99	\$ 349.98
Shower	1	Ea.	\$ 899.00	\$ 899.00
Shower/Tub Combo	1	Ea.	\$ 1,744.90	\$ 1,744.90
Bathroom Sink	2	Ea.	\$ 649.00	\$ 1,298.00
Kitchen Island	1	Ea.	\$ 499.00	\$ 499.00
Kitchen Sink	1	Ea.	\$ 329.00	\$ 329.00
Cabinets	15	L.F.	\$ 500.00	\$ 7,500.00
Laminate Countertops	5	3 L.F.	\$ 79.98	\$ 399.90
Closet Doors	6	Ea.	\$ 81.44	\$ 488.64
Interior Doors	5	Ea.	\$ 350.00	\$ 1,750.00
Wooden Stairs	2	Ea.	\$ 750.00	\$ 1,500.00
		Sum		<b>\$ 37,907.04</b>

Doors and Windows				
Component	Quantity	Unit	Unit Cost	Direct Cost
Alpen 925 Series Windows	162	S.F.	\$ 87.59	\$ 14,189.58
Exterior Doors	2	Ea.	\$ 6,335.00	\$ 12,670.00
Sliding Glass Doors	40	S.F.	\$ 95.00	\$ 3,800.00
		Sum		<b>\$ 30,659.58</b>
		Estimate Subtotal		<b>\$ 164,859.49</b>
		Contingency (10%)		<b>\$ 16,485.95</b>
		Estimate Total		<b>\$ 181,345.44</b>
		Cost/Ft <sup>2</sup>		<b>\$ 145.08</b>

## 04.2 ANNUAL CASH FLOW ANALYSIS

The cash flow analysis indicates that based on the \$75,000 MFI for the city of Denver and considering the annual affordability of 33% of the specified MFI, the Harvest Home is cost-effective from a buyers perspective with a positive cash flow of \$1,472.72.

### Anticipated Maintenance

Critical components identified as requiring replacement over the 30 year mortgage period are the Energy Recovery Ventilator (ERV), the mini-split heating and cooling system, and all major home appliances. Annual maintenance costs are summarized in Table 04.2-C.

Assuming all critical components require replacement once during the mortgage period, the cost of maintenance is calculated to total \$534.81 per year. Adding this to the affordability estimate, the net annual cash flow would be positive \$937.91. Assuming that all critical components require replacement twice during the mortgage period, the cost of maintenance would total \$1,069.61 per year and the net annual cash flow would remain be positive at \$403.11. From this analysis one can make the assumption that the maintenance requirements of the home are likely to be within the overall affordability of the home and therefore no negative results on family cash flow are anticipated.

Table 04.2-A: Annual Cash Flow Breakdown

Annual Cash Flow	
Median Family Income (MFI)	\$ 75,000.00
<b>Affordable Income for Housing</b>	
MFI x 33%	\$ 25,000.00
<b>Expense</b>	
Mortgage Payment	-\$ 17,615.28
Property Taxes	-\$ 2,250.00
Insurance	-\$ 2,655.00
Utilities	-\$ 632.00
Debt Repayment	-\$ 375.00
<b>Net Annual Cash Flow</b>	\$ 1,472.72

Table 04.2-B: Mortgage Term Maintenance Costs

Maintenance Over 30 Year Mortgage Period	Annual Cost	Net Cash Flow
Critical Components Replaced Once	\$ 534.81	\$ 937.91
Critical Components Replaced Twice	\$ 1,069.62	\$ 403.11

Table 04.2-C: Anticipated Maintenance Cost Estimate

Ventilation				
Component	Quantity	Unit	Unit Cost	Direct Cost
UltimateAir 200DX ERV	1	Ea.	\$ 2,061.19	\$ 2,061.19
WarmFlo Duct Heater 1.0 kW	1	Ea.	\$ 501.10	\$ 501.10
ERV Install	8	hr	\$ 88.22	\$ 705.75
			Sum	<b>\$ 3,268.04</b>

Heating & Cooling				
Component	Quantity	Unit	Unit Cost	Direct Cost
MXZ-2B20 Outdoor with two MSZ-GE06 Indoor	1	Ea.	\$ 2,343.39	\$ 2,343.39
Shipping (Complimentary)	1	Ea.	\$ -	\$ -
25' Minisplit Installation Kit	2	Ea.	\$ 251.95	\$ 503.90
Wall Mounting Bracket	3	Ea.	\$ 58.65	\$ 175.95
Minisplit Install	16	hr.	\$ 92.92	\$ 1,486.70
BHA-3 Heavy Duty Electric Baseboard Radiator	3	Ea.	\$ 77.40	\$ 232.20
			Sum	<b>\$ 4,742.14</b>

DHW				
Component	Quantity	Unit	Unit Cost	Direct Cost
GE GeoSpring Hybrid Water Heater	1	Ea.	\$ 1,299.99	\$ 1,299.99
Shipping (Complimentary)	1	Ea.	\$ -	\$ -
			Sum	<b>\$ 1,299.99</b>

Appliances				
Component	Quantity	Unit	Unit Cost	Direct Cost
Miele Cooktop	1	Ea.	\$ 1,199.00	\$ 1,199.00
Whirlpool Oven	1	Ea.	\$ 1,399.00	\$ 1,399.00
Range Hood	1	Ea.	\$ 699.00	\$ 699.00
Moffat Refrigerator	1	Ea.	\$ 899.00	\$ 899.00
Blomberg Dishwasher	1	Ea.	\$ 810.00	\$ 810.00
Blomberg Clothes Washer	1	Ea.	\$ 1,059.00	\$ 1,059.00
Blomberg Clothes Dryer	1	Ea.	\$ 669.00	\$ 669.00
			Sum	<b>\$ 6,734.00</b>

Maintenance Estimate	<b>\$ 16,044.18</b>
----------------------	---------------------

### High Performance Features

The Harvest Home is carefully designed to incorporate many high performance features while maintaining affordability. As high performance features are often associated with increased capital costs, a balance is maintained between high performance, low cost design, and minimized operations costs. The additional capital costs of these features are offset by efficient design and calculated use of materials. For example, the costs of highly insulating the building envelope and installing high performance windows are offset by the simple, yet contextually informed massing and arrangement. The compact footprint of the row house minimizes heat loss through the party walls and reduces material use by focusing the highly insulated portions of the building envelope to the front and rear facades; a considerably smaller area than a detached home. Also, building orientation, strategic shading design, as well as window placement and sizing take full advantage of beneficial solar heat gain and avoid overheating resulting in reduced heating and cooling costs for the homeowner over the building’s lifespan.

Table 04.2-D provides a summary of the cost of key high performance features compared to a conventional, single detached home (Taylor, 2011).

Table 04.2-D: High Performance Feature Cost Comparison

High Performance Features				
Component	Harvest Home	Conventional Home	Difference (\$)	Difference (%)
Foundation Insulation & Air Barrier	\$ 2,882.03	\$ -	\$ 2,882.03	-
Wall and Roof Constructions	\$ 23,557.04	\$ 35,701.00	-\$ 12,143.96	-41%
HVAC	\$ 9,436.58	\$ 8,760.00	\$ 676.58	7%
Appliances	\$ 6,734.00	\$ 3,619.00	\$ 3,115.00	60%
Windows & Doors	\$ 30,659.58	\$ 8,298.00	\$ 22,361.58	115%
<b>Sum</b>	<b>\$ 73,269.23</b>	<b>\$ 56,378.00</b>	<b>\$ 16,891.23</b>	<b>26%</b>

Based on these key high performance features, the Harvest home has a cost premium of \$16,891.23. The benefit of this cost premium is a significant reduction in annual utility bills, estimated at \$632/yr. for the Harvest Home compared to \$1,551/yr. for a conventional home (US Energy Information Administration, 2014), a savings of 41%.

Table 04.2-E outlines utility cost savings over the 30 year mortgage period assuming an average rate of inflation of 3% (Colorado Department of Local Affairs, 2014) and a rate of energy price increase of 8.5% (Bureau of Labor and Statistics, 2014).

Table 04.2-E: Annual Utility Cost Projection

	Annual Utility Costs		
	Harvest Home Utility Cost	Conventional Utility Cost	Difference
Year 1	\$ 632.00	\$ 1,551.00	\$ 919.00
Year 2	\$ 666.76	\$ 1,636.31	\$ 969.55
Year 3	\$ 703.43	\$ 1,726.30	\$ 1,022.87
Year 4	\$ 742.12	\$ 1,821.25	\$ 1,079.13
Year 5	\$ 782.94	\$ 1,921.42	\$ 1,138.48
Year 6	\$ 826.00	\$ 2,027.09	\$ 1,201.10
Year 7	\$ 871.43	\$ 2,138.59	\$ 1,267.16
Year 8	\$ 919.36	\$ 2,256.21	\$ 1,336.85
Year 9	\$ 969.92	\$ 2,380.30	\$ 1,410.38
Year 10	\$ 1,023.27	\$ 2,511.22	\$ 1,487.95
Year 11	\$ 1,079.55	\$ 2,649.33	\$ 1,569.78
Year 12	\$ 1,138.92	\$ 2,795.05	\$ 1,656.12
Year 13	\$ 1,201.56	\$ 2,948.77	\$ 1,747.21
Year 14	\$ 1,267.65	\$ 3,110.96	\$ 1,843.31
Year 15	\$ 1,337.37	\$ 3,282.06	\$ 1,944.69
Year 16	\$ 1,410.93	\$ 3,462.57	\$ 2,051.65
Year 17	\$ 1,488.53	\$ 3,653.01	\$ 2,164.49
Year 18	\$ 1,570.39	\$ 3,853.93	\$ 2,283.53
Year 19	\$ 1,656.77	\$ 4,065.89	\$ 2,409.13
Year 20	\$ 1,747.89	\$ 4,289.52	\$ 2,541.63
Year 21	\$ 1,844.02	\$ 4,525.44	\$ 2,681.42
Year 22	\$ 1,945.44	\$ 4,774.34	\$ 2,828.90
Year 23	\$ 2,052.44	\$ 5,036.93	\$ 2,984.49
Year 24	\$ 2,165.33	\$ 5,313.96	\$ 3,148.63
Year 25	\$ 2,284.42	\$ 5,606.23	\$ 3,321.81
Year 26	\$ 2,410.06	\$ 5,914.57	\$ 3,504.51
Year 27	\$ 2,542.62	\$ 6,239.87	\$ 3,697.26
Year 28	\$ 2,682.46	\$ 6,583.07	\$ 3,900.60
Year 29	\$ 2,830.00	\$ 6,945.13	\$ 4,115.14
Year 30	\$ 2,985.65	\$ 7,327.12	\$ 4,341.47
	<b>Sum</b>	<b>\$</b>	<b>66,568.20</b>

## 04.2 ANNUAL CASH FLOW ANALYSIS

### Long-Term Energy Cost Savings

Based on this analysis, over the course of the 30 year mortgage the Harvest Home will save the homeowner \$66,568.20 in utility costs compared to the initial cost premium of \$16,891.23 for the high performance features enabling the reduction of utility costs.

Table 04.2-F summarizes a sensitivity analysis on the utility cost savings with varying inflation rates and energy price inflation:

Table 04.2-F: Energy Cost Sensitivity Analysis

Inflation (%)	Energy Cost Increase (%)			
	3	5	8.5	10
1	\$ 37,282.06	\$ 51,542.06	\$ 95,024.05	\$ 125,266.63
3	\$ 27,570.00	\$ 37,282.06	\$ 66,568.20	\$ 89,027.06
4.7	\$ 21,738.77	\$ 28,803.57	\$ 49,853.42	\$ 64,298.08

Based on the above investigation, the Harvest Home will save the homeowner between \$21,738.77 and \$125,266.63 over the 30 year mortgage period compared to the initial cost premiums associated with high performance features totalling \$16,891.23. Therefore, even at the conservative end of the sensitivity analysis, the initial cost premium is outweighed by the utility savings over the 30 year mortgage period.

### Renewable Energy

Although the Harvest Home will not include renewable energy generation in its initial construction, the home has been designed to be photovoltaic ready, thereby allowing homeowners to easily install solar collectors when funding permits. While the financial implications of on-site energy generation have not been included in the demonstrated analysis, the potential for homeowners to generate energy to further offset utility costs or to generate income from selling energy to the grid is made possible through design considerations for the potential future accommodation of photovoltaic panels.



## 04.3 AFFORDABILITY ANALYSIS

### PITIUI Method

The affordability analysis is undertaken using a PITIU assessment where the cost of the home must not exceed 33% of the Median Family Income (MFI) in the home's location. PITIU stands for; Principal (P), Interest (I), Property Taxes (T), Home and Mortgage Insurance (I), and Utilities (U). The MFI for the City of Denver is approximately \$75,000 (US Department of Housing and Urban Development, 2013). Employing this method, the maximum cost of the home is determined to be \$25,000 annually. The financial parameters of the PITIU assessment as per the DOE Home Challenge guidelines are as follows;

#### Principal and Interest:

Financing based on 30 year fixed rate mortgage at 4.5% with down payment of 20% MFI

Property Taxes: 3% of MFI

#### Home and Mortgage Insurance:

Home Ins. of \$780 & Mortgage Ins. of 2.5% MFI

Utilities: As per local utility costs

Monthly Household Debt Payment: 0.5% of MFI

### Principle and Interest

The principle cost of the Harvest Home is based on the construction cost and the non-construction costs. Based on the DOE guidelines, the non-construction costs are estimated at 40.6% of the sales price. The sales cost is calculated as follows:

$$\text{Sales Price (P}_s\text{)} = \text{Construction Cost (C}_c\text{)} / (1 - 0.406)$$

$$P_s = 181,345.44 / 0.594$$

$$P_s = \$305,295.35$$

$$\text{Non-Construction Costs (C}_{NC}\text{)} = \$123,949.91$$

Considering a down payment of 20% x MFI (\$15,000), the total loan is projected to be \$290,295.35.

To calculate the monthly payments for the home, the following formula is used:

$$P = L[c(1 + c)^n] / [(1 + c)^n - 1]$$

$$N = \# \text{ of Payments} = 12 \text{ months} * 30 \text{ Years} = 360$$

$$L = \text{Loan} = \text{Sales Price} - \text{Down payment} \\ = (\$307,207.89 - \$15,000) = \$290,295.35$$

$$C = \text{Period Interest Rate} = (4.5\% / 12 \text{ months}) = 0.00375$$

P = Monthly Payment

$$\text{Total Monthly Payment} = \$1,467.94 \text{ or } \$17,615.28/\text{year}$$

### Property Taxes, Insurance, Utilities & Debt

$$T = \text{Property taxes} = 3\% \times \text{MFI} = \$2,250$$

$$I = \text{Home \& Mortgage Ins.} = \$780 + (2.5\% \times \text{MFI}) = \$1,875$$

$$U = \text{Utilities} = \$632 \text{ (as per HERS rating)}$$

$$D = \text{Household Debt} = 0.5\% \times \text{MFI} = \$375$$

### Total Cost

$$\text{Total Cost (C}_T\text{)} = \text{PI} + \text{T} + \text{I} + \text{U} + \text{D}$$

$$C_T = \$17,615.28 + \$2,250 + \$780 + \$1,875 + \$632 + \$375$$

$$C_T = \$23,527.28/\text{year}$$

With an overall annual cost of \$23,527.28 based on the given financial parameters as well as the calculated utility costs, the Harvest Home is considered to be an affordable housing option based on the Denver's specified Median Family Income value.

## 05.0 ENVELOPE DURABILITY

### Design Approach

The building envelope is designed taking into consideration the three major mechanisms that affect envelope durability; heat, air, and moisture transport. Heat transport must be controlled to limit the heat energy escaping the home during colder times of the year and to limit heat energy infiltrating the building during summer months. Air transport must be controlled both to limit hot and cold air from uncontrollably infiltrating and exfiltrating the building, contributing to higher heating and cooling loads, as well as to avoid interstitial condensation deposited in the envelope assembly leading to moisture damage and deterioration. Finally, moisture transport must be controlled by deflecting and draining bulk precipitation water and by allowing moisture that is transported into the assembly by diffusion to dry out in order to avoid damage and deterioration of building components. The envelope has been designed to deflect rain, soil moisture, and snow, but also to allow drainage should water pass behind the cladding. The envelope has also been designed to be vapor open allowing any moisture that is deposited in the assembly to dry to either the interior or exterior of the assemblies.

### ENERGY STAR Certification

The Harvest Home has been designed to meet the requirements for ENERGY STAR certification. During construction of the building envelope the Thermal Enclosure System Rater Checklist is to be completed by a third-party inspector to confirm compliance with ENERGY STAR National Program Requirements.

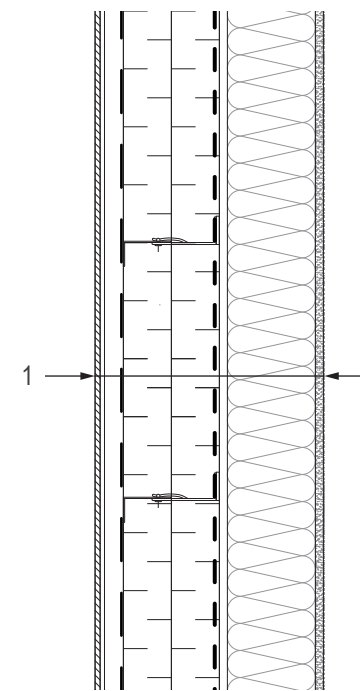

- 1 Exterior Wall Assembly (Exterior to Interior)  
 Fibre-C Ecoclad  
 Continuous Vertical Rail for Anchoring  
 1" Ventilation Cavity  
 Tyvek Weather Barrier Ship-Lapped  
 2 Layers - 3" Roxul EPS Insulation (R-25.8)  
 1/2" Zip System Air/Vapor Barrier  
 2 x 6" Structural Stud Wall at 16" O/C  
 5-1/2" Cellulose Insulation (R-21)  
 1/2" Gypsum Wall Board  
 Zero VOC Paint Finish

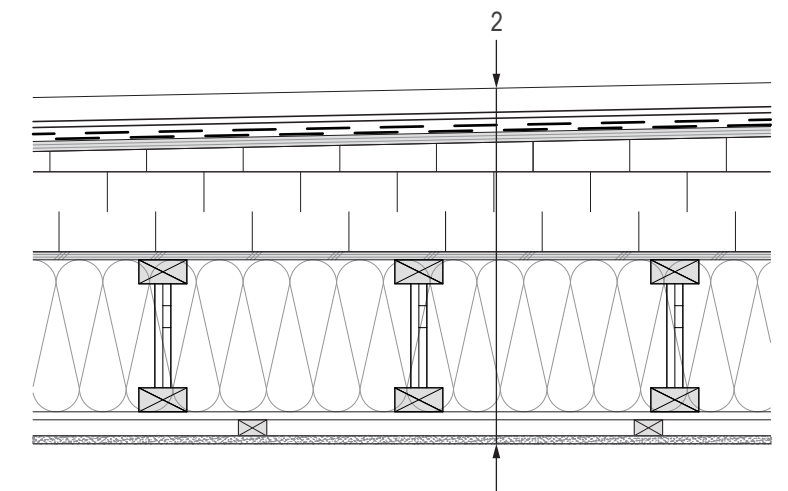

- 2 Roof Assembly (Exterior to Interior)  
 Galvanized Standing Seam Metal Roof  
 2 Layers - 15 lb. Roofing Felt  
 5/8" Plywood Sheathing  
 EPS Rigid Insulation (R-20)  
 1/2" Plywood Sheathing  
 2 x 10" Wood Joists at 16" O/C  
 9-1/2" Blown Cellulose Insulation (R-33.25)  
 1/2" Zip System Air/Vapor Barrier  
 1" Wood Furring  
 5/8" Gypsum Wall Board  
 Zero VOC Paint Finish

## 05.1 HYGROTHERMAL ANALYSIS

### Exterior Wall Assembly

Heat transport across the exterior walls of the building is controlled by providing continuous, highly resistive insulation on the complete exterior of the building as well as within stud cavities. This minimizes heating and cooling costs and increases occupant comfort by eliminating cold areas of the home and overheating. By providing continuous exterior insulation in addition to stud cavity insulation, thermal bridges are avoided at framing elements, as well as wall to floor, wall to roof, and wall to slab junctions. The PSI values at critical points in the assembly are determined to be between  $-0.0609$  W/mK and  $-0.1418$  W/mK. A negative number indicates the absence of a thermal bridge.

Air transport is controlled in the wall assemblies using air tight Zip System sheathing complete with fully taped seams. This layer is continuous with an air tight 10 mil polyethylene air barrier layer beneath the slab foundation. The Zip System sheathing is also sealed with expanding foam gaskets at all window penetrations.

Bulk water due to precipitation is controlled using a rain screen approach. Bulk water is initially shed by the cladding. Bulk water that penetrates the cladding is drained out of the wall assembly by a weather barrier drainage plane interconnected with sloped flashing to expel water at the base of the wall. Moisture within the assembly is naturally managed by allowing the wall assembly to be vapor open, meaning that any water vapor that enters the assembly is free to dry to the interior or exterior of the wall, minimizing the length of time that any material is exposed to moisture. Finally, the continuous insulation at the exterior of the wall assembly ensures that the main wall components are kept warm even during the winter months. This reduces the possibility that warm, moist air from the building interior will condense on cold surfaces in the wall. Rather, warm, moist air is likely to condense near the exterior of the building in the exterior insulation layers that are free draining and do not support the growth of mould or rot.

### Flat & Sloped Roof Assemblies

Similar to the exterior walls, heat transport across the roof of the building is controlled by providing continuous, highly resistive insulation. Rigid insulation boards provide continuous insulation at the exterior of the roof framing eliminating thermal bridging. Blown cellulose insulation between the roof framing meets the exterior insulation of the wall assembly providing an insulated transition between the exterior wall and the roof assemblies.

Air transport is controlled in the roof by continuing the air tight Zip System sheathing with taped seams from the wall assembly across the interior of the roof. Furring strips are installed on the interior of the Zip System sheathing to provide a drop ceiling, thus avoiding any penetrations in the air barrier by lighting or decorative installations.

Moisture transport is controlled using a vented drainage plane approach. Bulk water is shed by the impermeable roof cladding while a rubber roofing membrane drains water that penetrates the cladding. In order to avoid moisture infiltration caused by ice dams and snow cover, the roof cladding is ventilated and remains cold. This ensures that heat rising from the interior is removed by exterior ventilated air and does not melt snow or ice on the roof which can then become trapped as liquid water behind ice dams and seep into the assembly. Water vapor is controlled naturally by allowing the wall assembly to be vapor open to the interior of the building. This means that any water vapor that enters the assembly is free to dry to the interior of the building. Similar to the exterior wall assembly, the continuous insulation at the exterior of the roof assemblies ensures that the main wall components are kept warm during winter months. This reduces the possibility that warm, moist air from the building interior will condense on cold surfaces within the roof.

## 05.1 HYGROTHERMAL ANALYSIS

### Exterior Wall Assembly

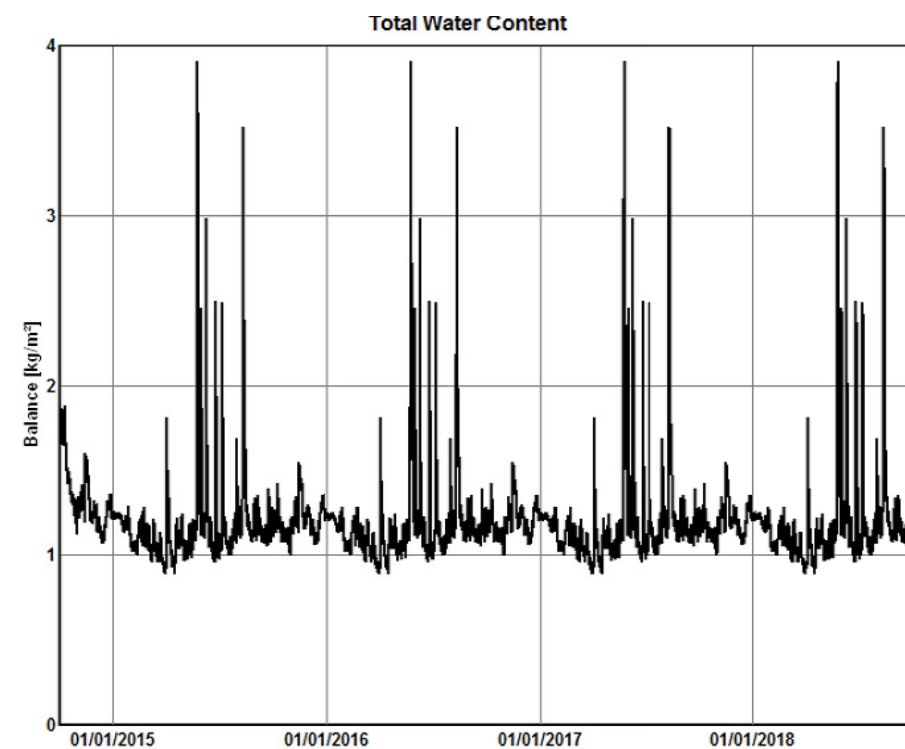

The total water content in the wall assembly is low and remains in equilibrium throughout the four year modelling period. This indicates that moisture is not accumulating in the assembly and therefore moisture damage and deterioration is not expected.

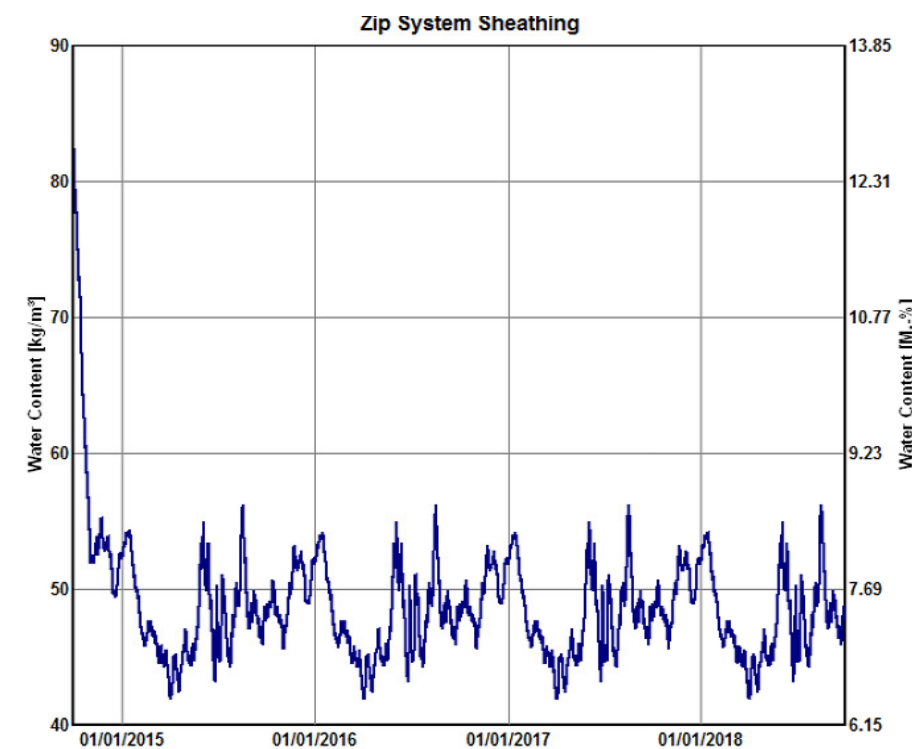

The total water content in the wall sheathing reduces quickly and then reaches equilibrium. This indicates that the moisture contained in the sheathing at the time of construction quickly dries and over the four year modelling period moisture does not accumulate in the sheathing. Considering the equilibrium moisture content in the sheathing is less than the critical value of 18%, moisture damage and deterioration in the sheathing is not expected.

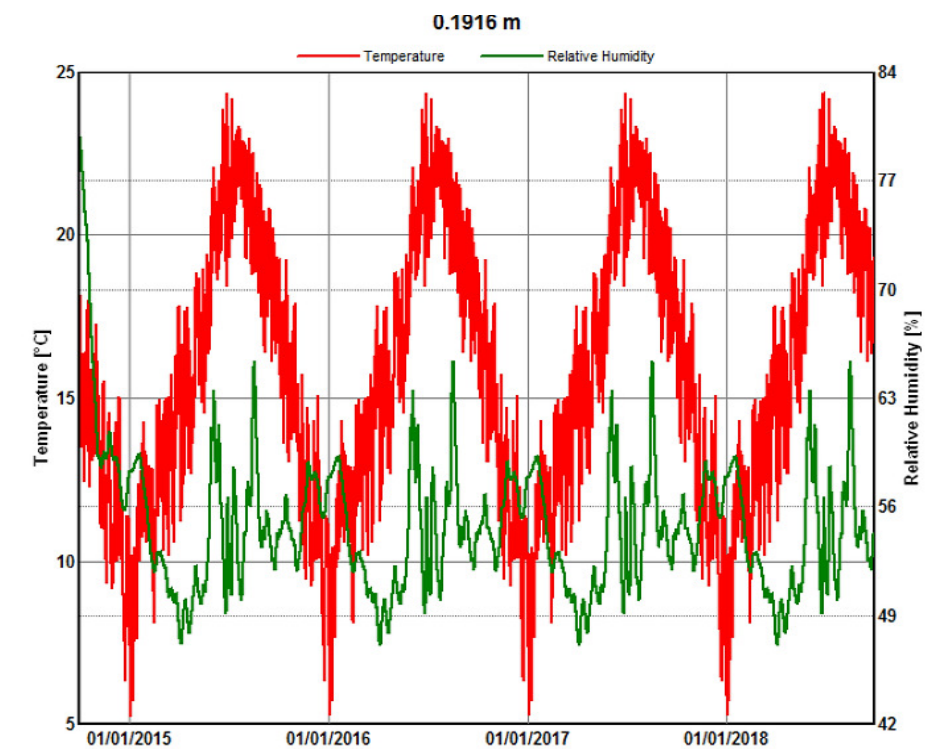

The relative humidity of the sheathing reduces quickly and reaches equilibrium for the remainder of the four year modelling period. As the relative humidity stabilizes below the critical value of 80% moisture damage and deterioration is not expected.

### Sloped Roof Assembly

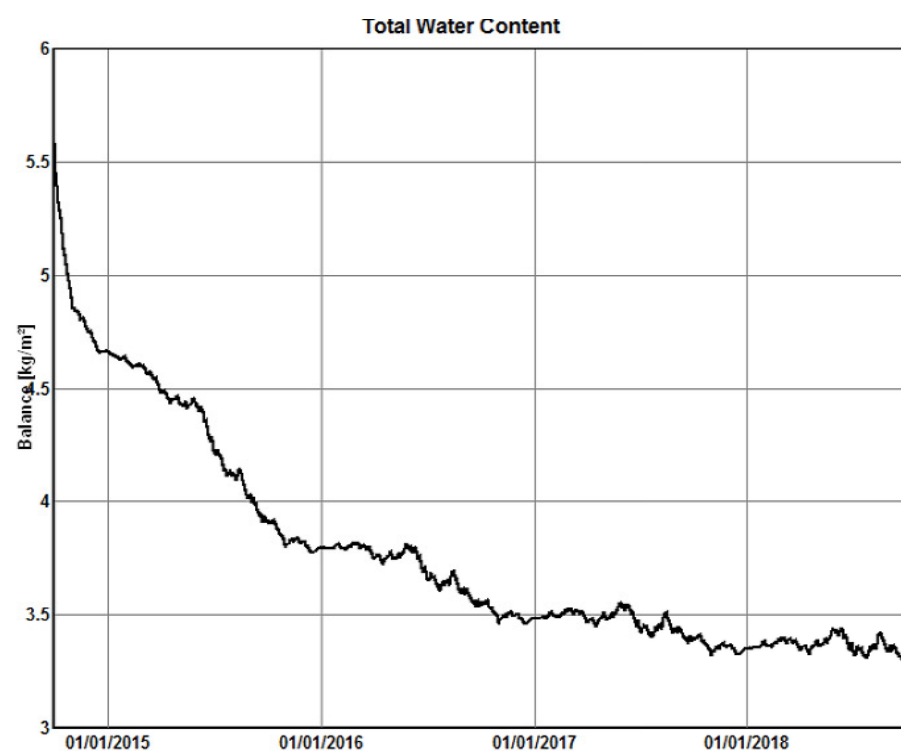

The total water content in the sloped roof assembly continually decreases over the four year modelling period. This demonstrates a drying trend and indicates that moisture is not accumulating in the assembly. Therefore moisture damage and deterioration is not expected.

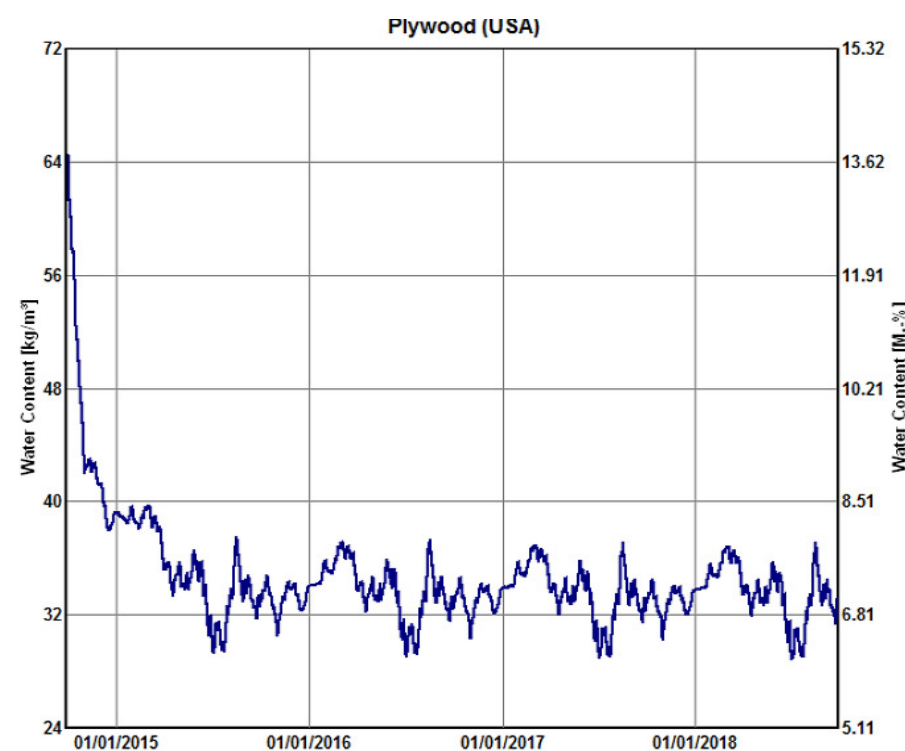

The total water content in the sloped roof sheathing reduces quickly and then reaches equilibrium. This indicates that the moisture contained in the sheathing at the time of construction quickly dries and moisture does not accumulate in the sheathing over the four year modelling period. Considering the equilibrium moisture content in the sheathing is less than the critical value of 18%, moisture damage and deterioration in the sheathing is not expected.

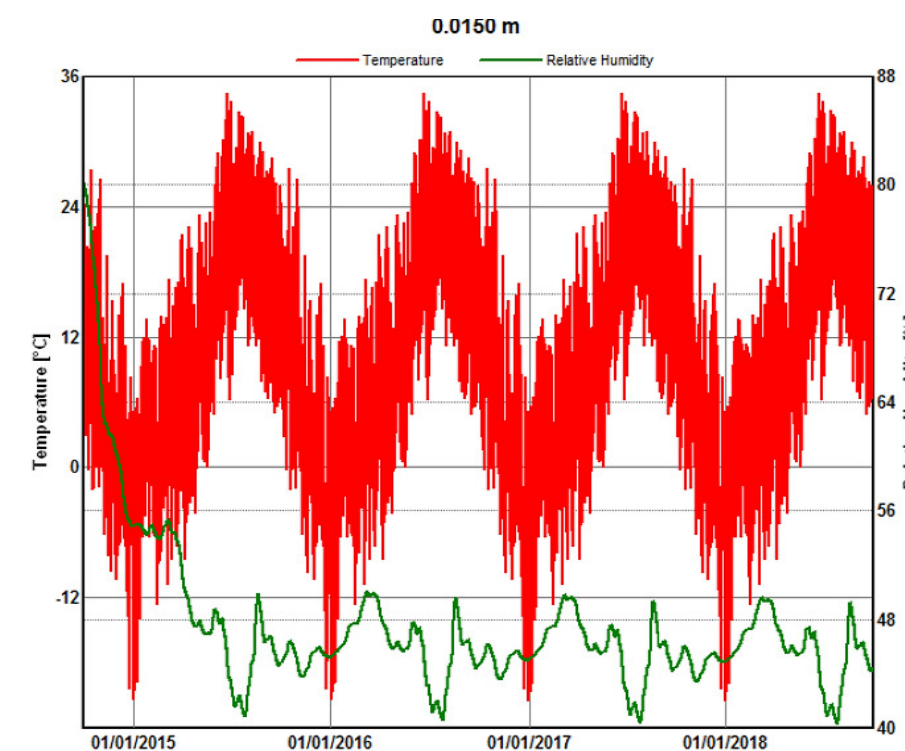

The relative humidity of the sheathing reduces quickly and reaches equilibrium for the remainder of the four year modelling period. As the relative humidity stabilizes below the critical value of 80%, moisture damage and deterioration is not expected.

## 05.1 HYGROTHERMAL ANALYSIS

### Flat Roof Assembly

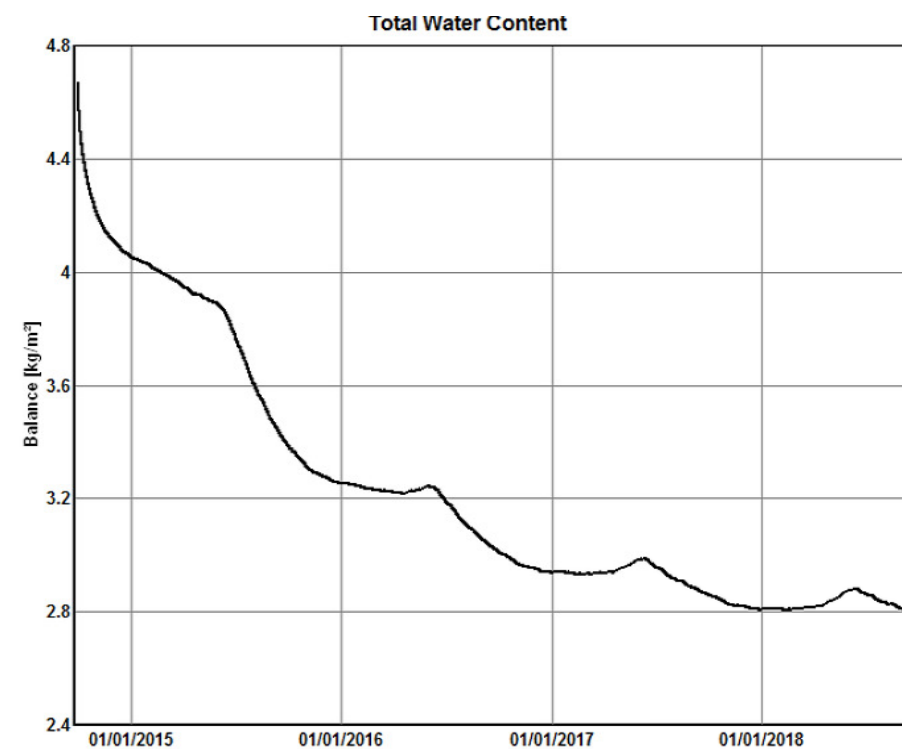

The total water content in the flat roof assembly continually decreases over the four year modelling period. This indicates a drying trend and that moisture is not accumulating in the assembly. Therefore moisture damage and deterioration is not expected.

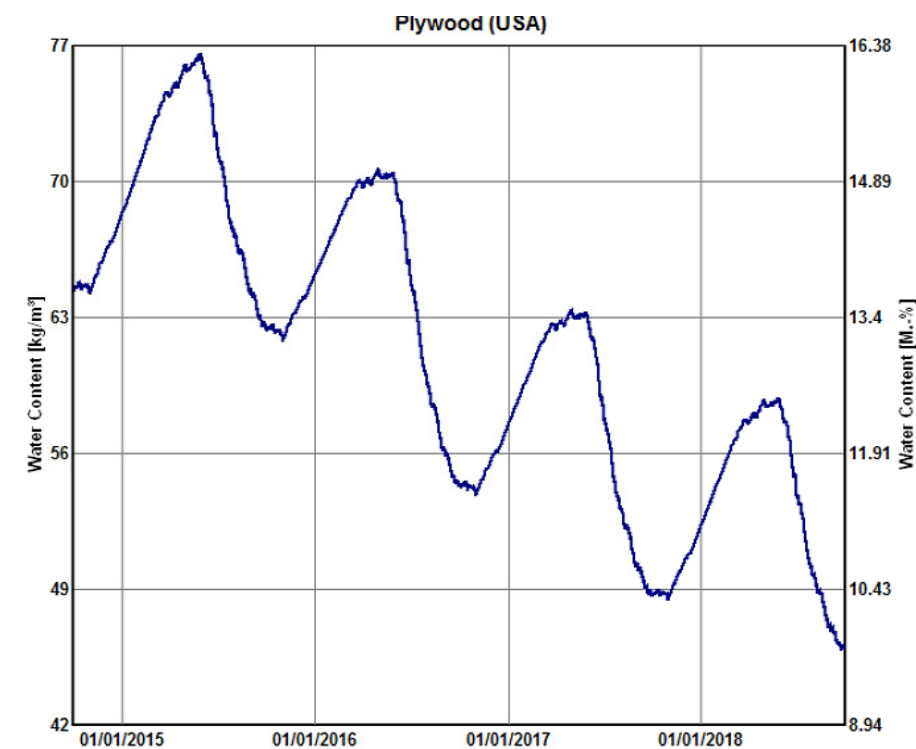

The water content in the flat roof sheathing continually decreases over the four year modelling period. This indicates a drying trend and that moisture is not accumulating in the assembly. Considering the equilibrium moisture content in the sheathing is less than the critical value of 18%, moisture damage and deterioration in the sheathing is not expected.

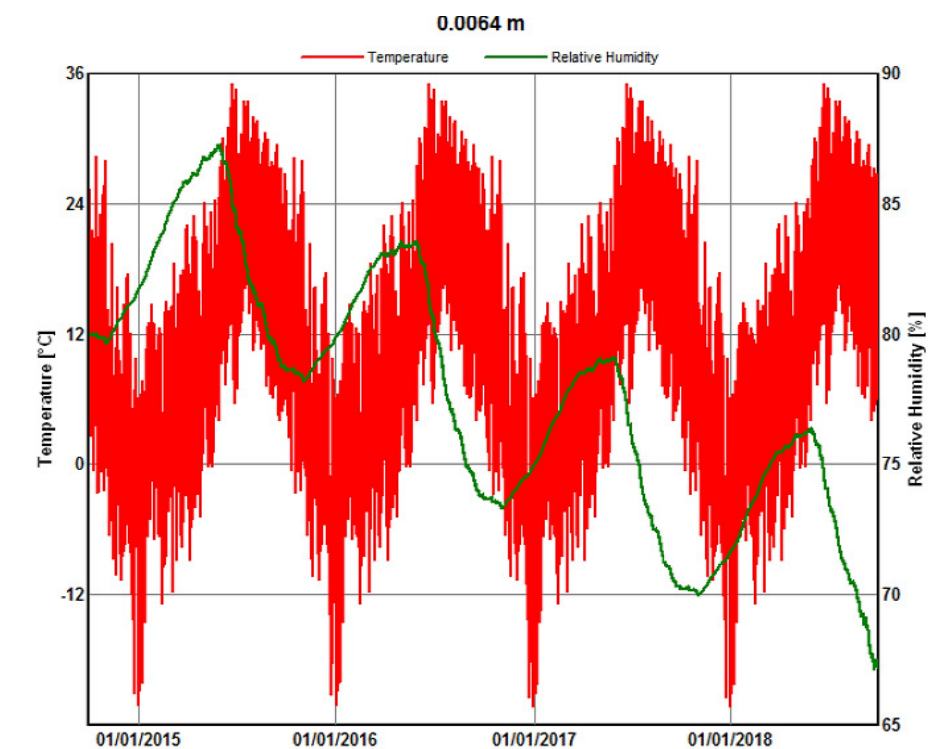

The relative humidity of the flat roof sheathing continually decreases over the four year modelling period. Although the relative humidity remains above the critical value of 80% for two years of the modelling period, the overall moisture content (from the previous figure) does not exceed 18% during the modelling period. This indicates that although the relative humidity begins high, the assembly is not expected to experience moisture damage or deterioration.

# 05.2 ENVELOPE SECTION

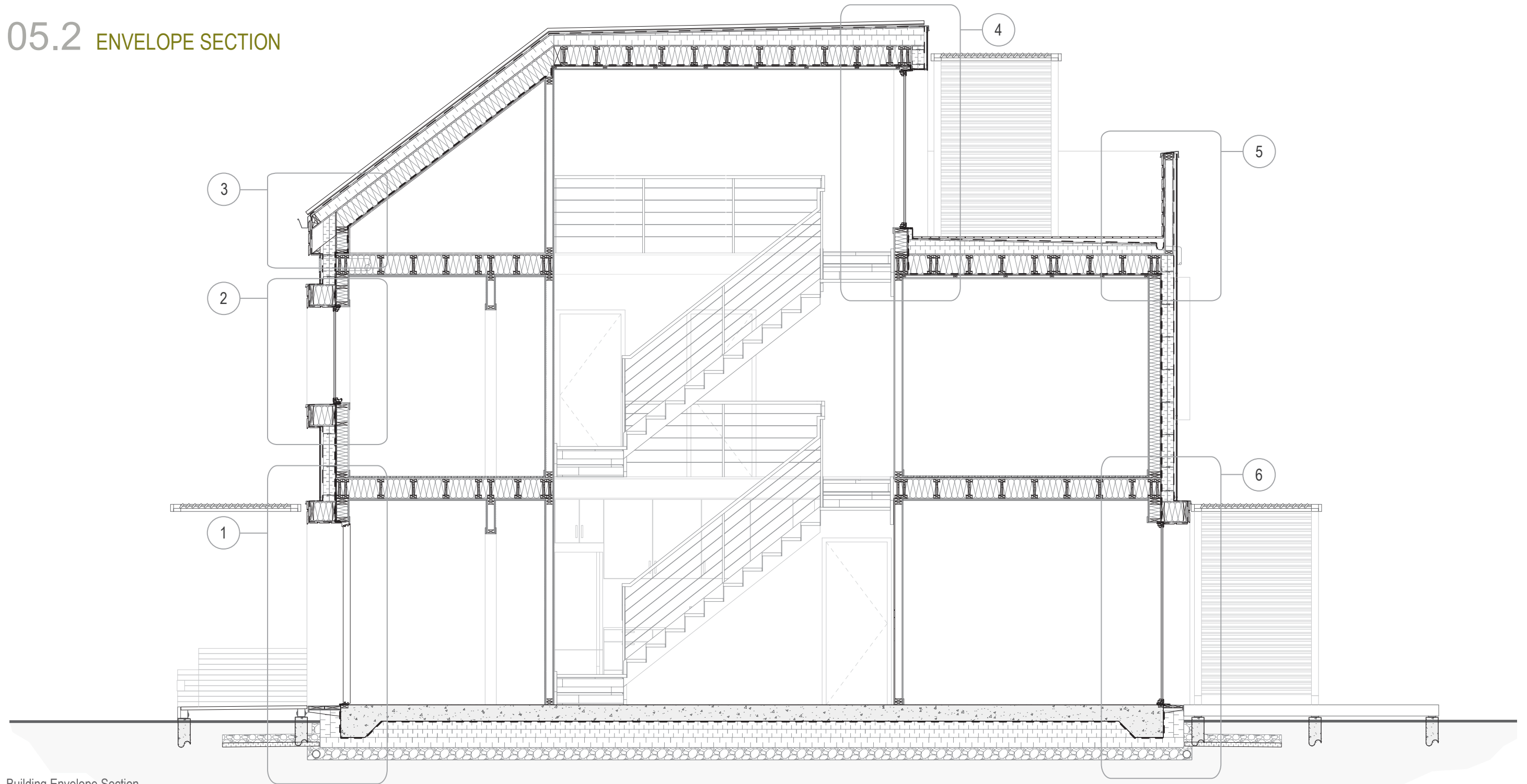

Building Envelope Section  
Scale: 1/4" = 1'-0"

## 05.3 ENVELOPE DETAILING

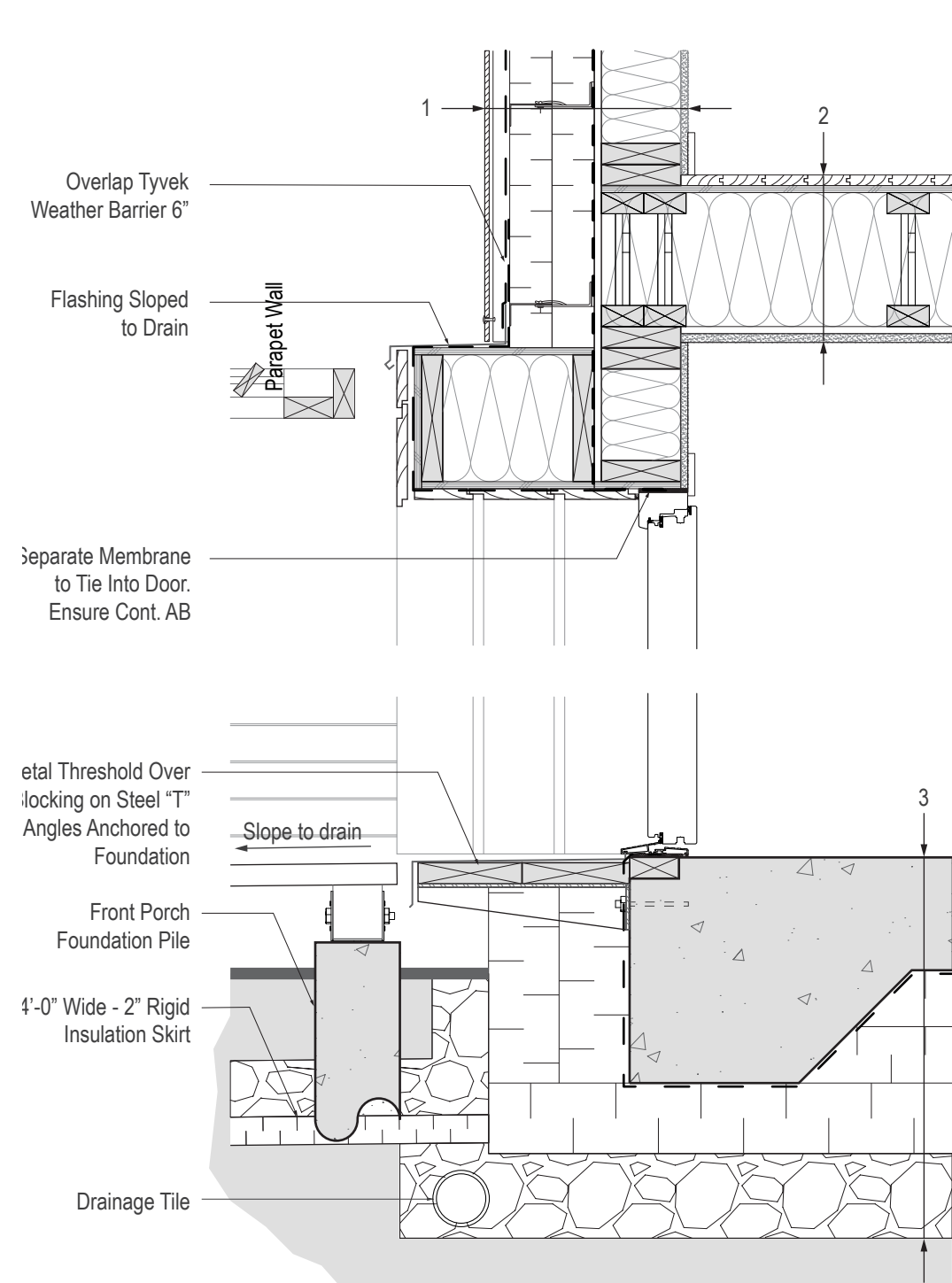

Detail 1 - Entry Door Sill & Top Plate  
Scale: 1" = 1'-0"

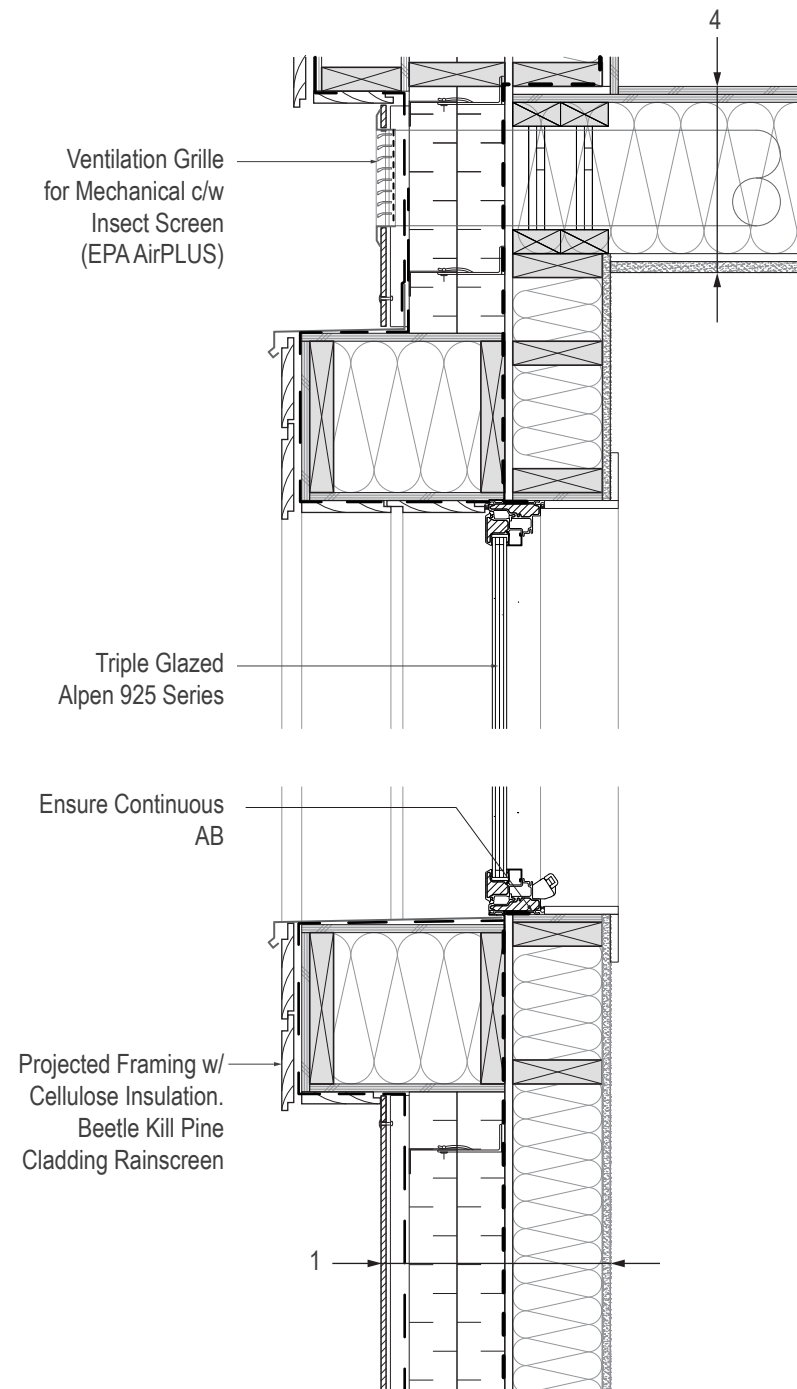

Detail 2 - North Aperture Sill & Top Plate  
Scale: 1" = 1'-0"

- 1 **Exterior Wall Assembly (Exterior to Interior)**  
Fibre-C Ecoclad on  
Continuous Vertical Rail for Anchoring  
1" Ventilation Cavity  
Tyvek Weather Barrier Ship-lapped for Drainage  
2 Layers - 3" Roxul EPS Insulation (R-25.8)  
1/2" Zip System Air/Vapor Barrier  
2 x 6" Structural Stud Wall at 16" O/C  
5-1/2" Cellulose Insulation (R-21)  
5/8" Gypsum Wall Board Finished w/  
Zero VOC Paint (EPA AirPLUS)
- 2 **Upper Floor Floor Assembly (Floor to Ceiling)**  
1/2" Beetle Kill Floor w/ Waterbase Finish (EPA AirPLUS)  
1/2" Plywood Subfloor  
9-1/2" Engineered Wood Joist w/ Acoustic Insulation Roxul  
AFB Resilient Channels  
5/8" Gypsum Wall Board Finished w/  
Zero VOC Paint (EPA AirPLUS)
- 3 **Ground Floor Assembly (Interior to Exterior)**  
8" Sealed Concrete Slab on Grade  
EPS Rigid Foam Raft (R-47.6)  
10 mil Poly Air Barrier  
6" Compacted Gravel (EPA AirPLUS)
- 4 **Mechanical/Storage Floor Assembly (Floor to Ceiling)**  
1/2" Plywood Floor  
1/2" Plywood Subfloor  
9-1/2" Engineered Wood Joist w/ Acoustic Insulation Roxul  
AFB Resilient Channels  
5/8" Gypsum Wall Board Finished w/  
Zero VOC Paint (EPA AirPLUS)



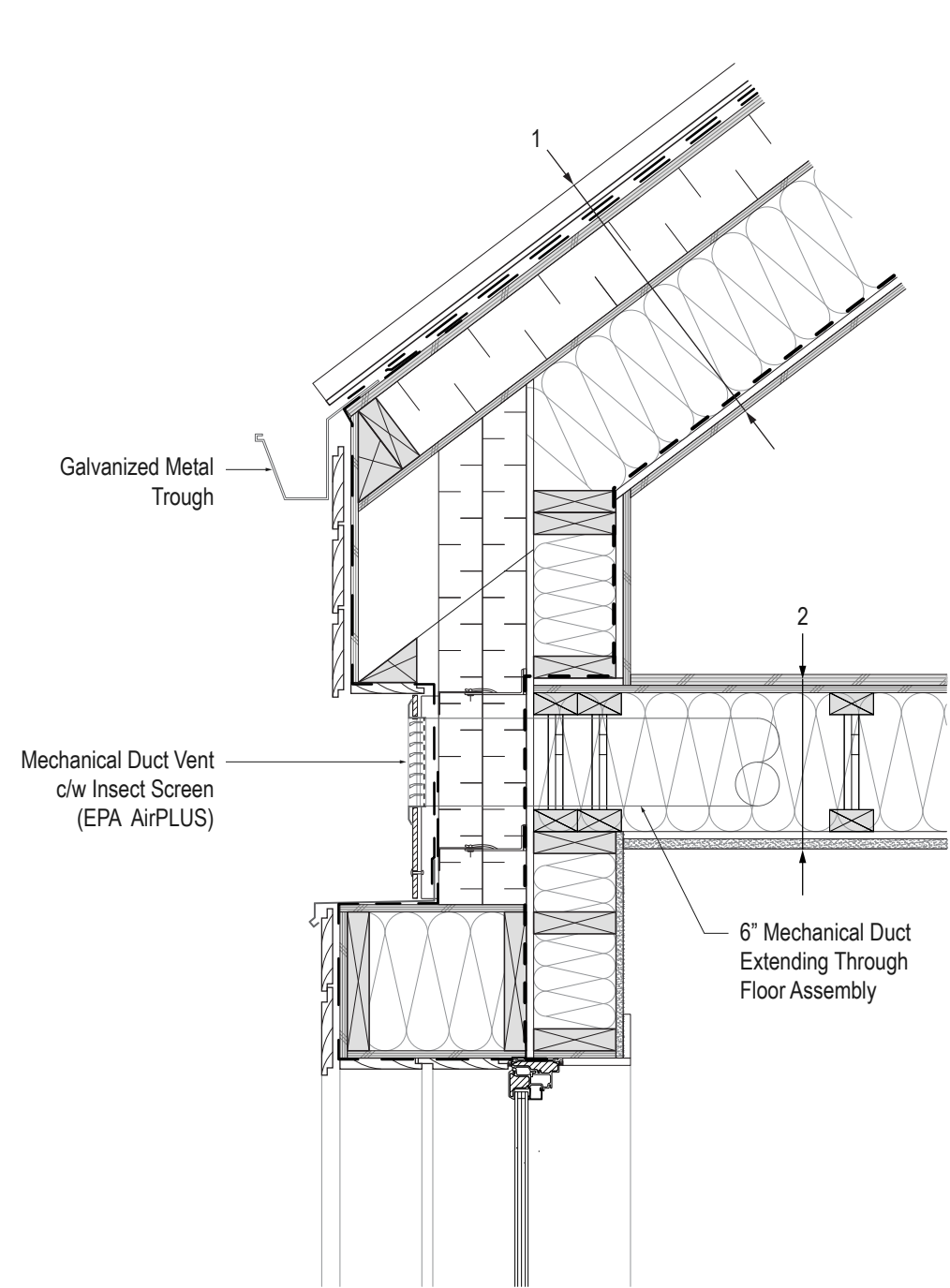

Detail 3 - North Wall Junction to Roof  
Scale: 1" = 1'-0"

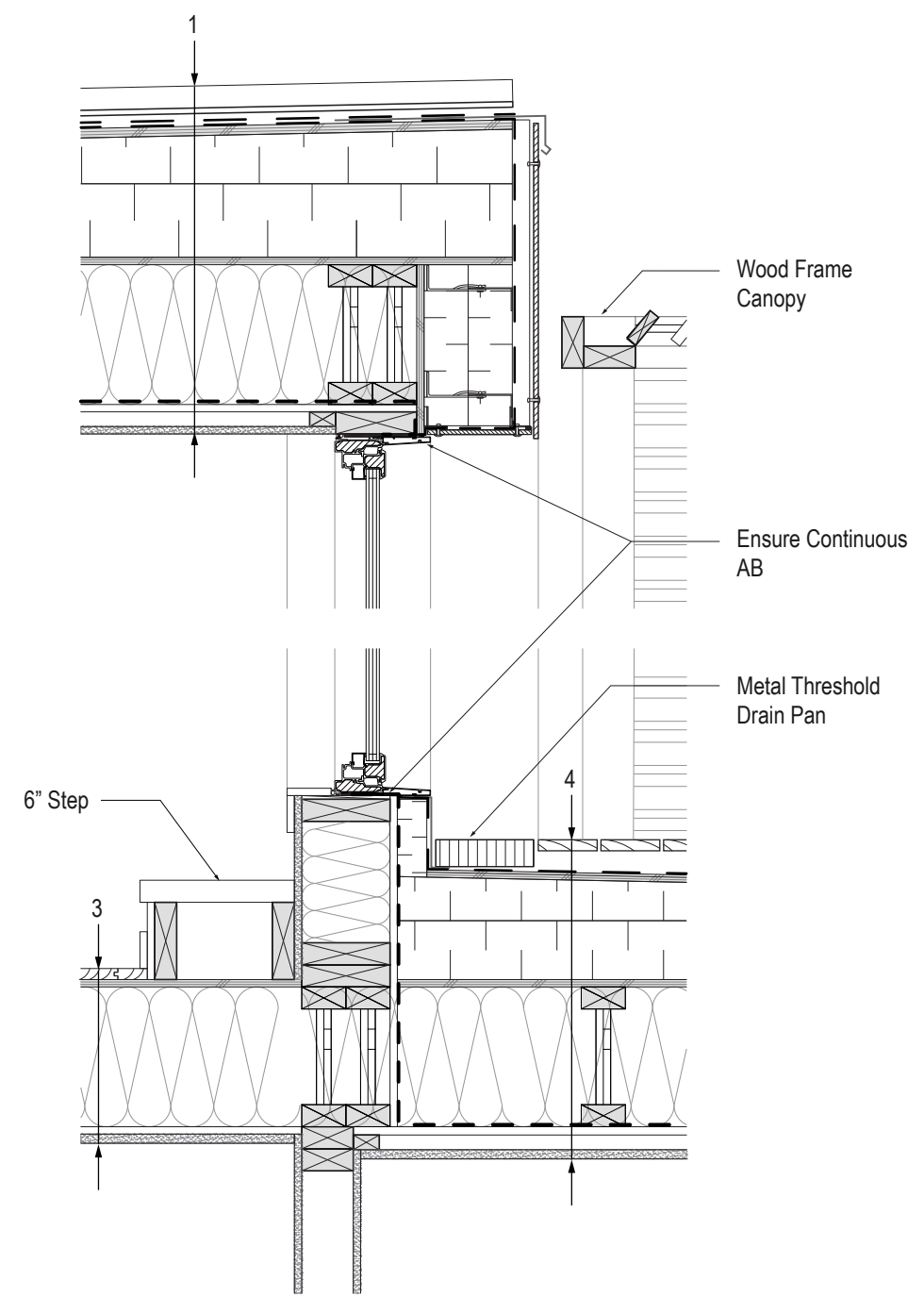

Detail 4 - Terrace Door Sill & Top Plate  
Scale: 1" = 1'-0"

- 1 | Roof Assembly (Exterior to Interior)  
Galvanized Standing Seam Metal Roof  
2 Layers - 15 lb. Felt  
5/8" Plywood Sheathing  
EPS Rigid Insulation (R-20)  
1/2" Plywood Sheathing  
2 x 10" Wood Rafters at 16" OC  
9-1/2" Blown Cellulose Insulation (R-33.25)  
1/2" Zip System Air/Vapor Barrier  
1" Wood Furring  
5/8" Gypsum Wall Board Finished w/  
Zero VOC Paint (EPA AirPLUS)
- 2 | Mechanical/Storage Floor Assembly (Floor to Ceiling)  
1/2" Plywood Floor  
1/2" Plywood Underlay  
9-1/2" Engineered Wood Joist w/ Acoustic Insulation Roxul  
AFB Resilient Channels  
5/8" Gypsum Wall Board Finished w/  
Zero VOC paint (EPA AirPLUS)
- 3 | Upper Floor Assembly (Floor to Ceiling)  
1/2" Beetle Kill Floor w/ Waterbase Finish (EPA AirPLUS)  
1/2" Plywood Subfloor  
9-1/2" Engineered Wood Joist w/ Acoustic Insulation Roxul  
AFB Resilient Channels  
5/8" Gypsum Wall Board Finished w/  
Zero VOC Paint (EPA AirPLUS)
- 4 | Roof Deck Assembly (Exterior to Interior)  
Beetle Kill Pine Deck Planks on Pads  
2-ply SBS Roofing Membrane  
1/2" Plywood Sheathing  
7" EPS Rigid Insulation Sloped to Drain (Min. 2%)  
1/2" Plywood Sheathing  
9-1/2" Engineered Wood Joist w/ Acoustic Insulation Roxul  
9-1/2" Blown Cellulose Insulation (R-33.25)  
1/2" Zip System Air/Vapor Barrier  
1" Wood Furring  
5/8" Gypsum Wall Board Finished w/  
Zero VOC Paint (EPA AirPLUS)

## 05.3 ENVELOPE DETAILING

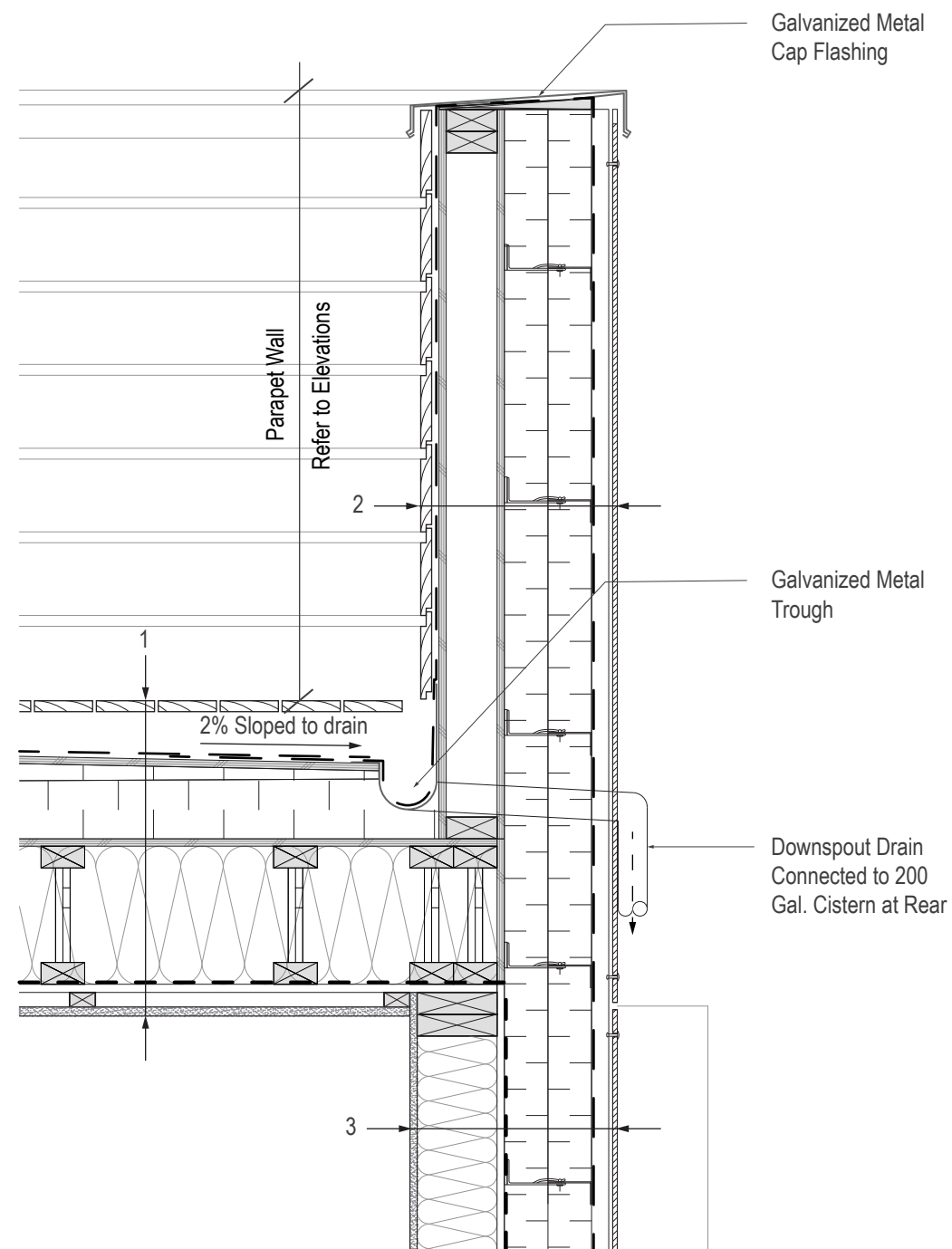

Detail 5 - South Parapet Assembly  
Scale: 1" = 1'-0"

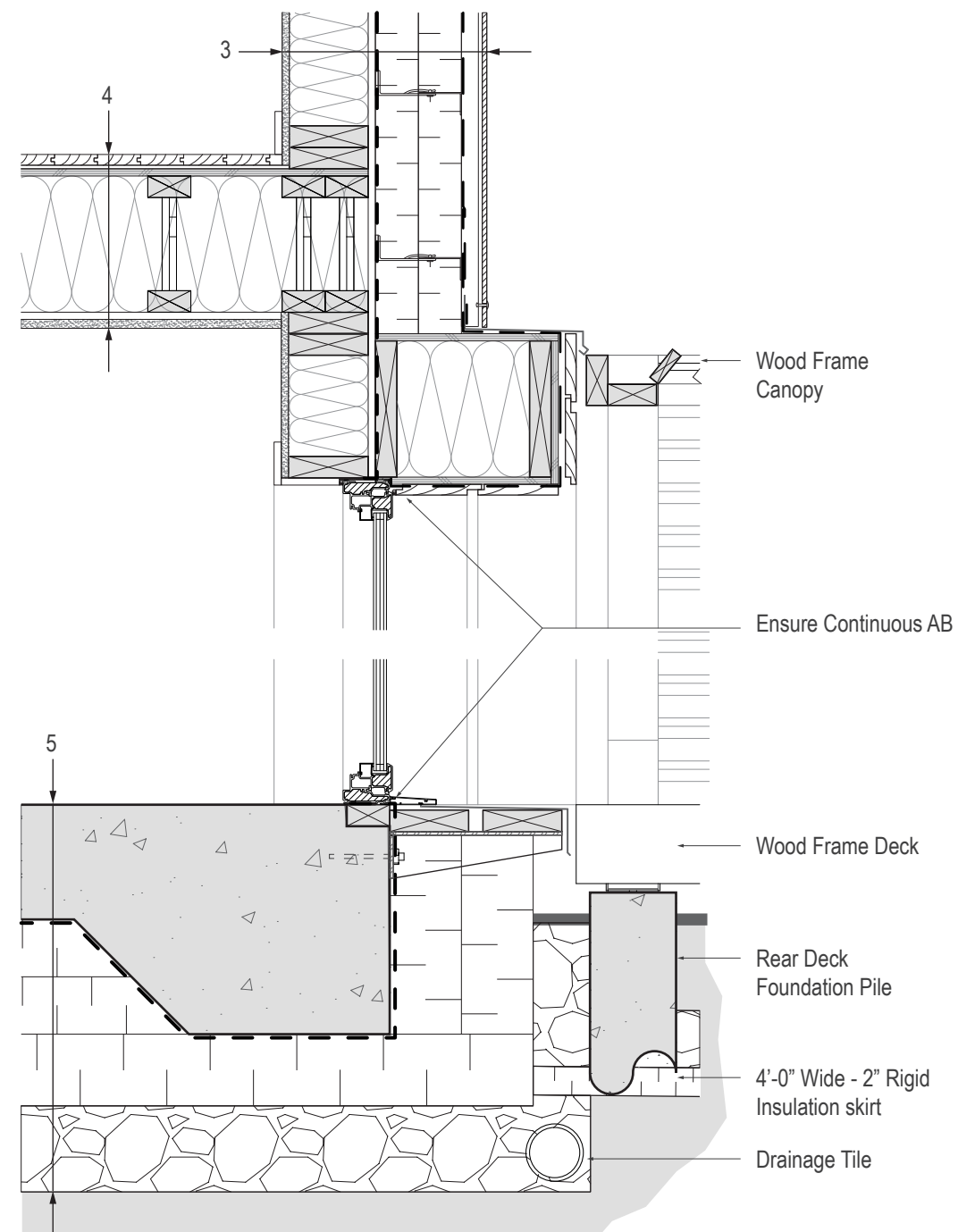

Detail 6 - Rear Deck Door Sill & Top Plate  
Scale: 1" = 1'-0"

- 1 **Roof Deck Assembly (Top to Ceiling)**  
 Beetle Kill Pine Deck Planks on Pads  
 2-ply SBS Roofing Membrane  
 1/2" Plywood Sheathing  
 7" EPS Rigid Insulation Sloped to Drain (Min. 2%)  
 1/2" Plywood Sheathing  
 9-1/2" Engineered Wood Joist w/ Acoustic Insulation Roxul  
 9-1/2" Blown Cellulose Insulation (R-33.25)  
 1/2" Zip System Air/Vapor Barrier  
 1" Wood Furring  
 5/8" Gypsum Wall Board Finished w/  
 Zero VOC Paint (EPA AirPLUS)
- 2 **Parapet Wall Assembly (Out to In)**  
 Fibre-C Ecoclad on  
 Continuous Vertical Rail for Anchoring  
 1" Ventilation Cavity  
 Tyvek Weather Barrier Ship-lapped for Drainage  
 2 Layers - 3" Roxul EPS Insulation (R-25.8)  
 1/2" Plywood Sheathing  
 2 x 4" Structural Stud Wall at 16" O/C  
 1/2" Plywood Sheathing  
 Tyvek Weather Barrier  
 1/2" Beetle Kill Pine Cladding
- 3 **Exterior Wall Assembly (Exterior to Interior)**  
 Fibre-C Ecoclad on  
 Continuous Vertical Rail for Anchoring  
 1" Ventilation Cavity  
 Tyvek Weather Barrier Ship-lapped for Drainage  
 2 Layers - 3" Roxul EPS Insulation (R-25.8)  
 1/2" Zip System Air/Vapor Barrier  
 2 x 6" Structural Stud Wall at 16" O/C  
 5-1/2" Cellulose Insulation (R-21)  
 5/8" Gypsum Wall Board Finished w/  
 Zero VOC Paint (EPA AirPLUS)
- 4 **Upper Floor Assembly (Floor to Ceiling)**  
 1/2" Beetle Kill Floor w/ Waterbase Finish (EPA AirPLUS)  
 1/2" Plywood Subfloor  
 9-1/2" Engineered Wood Joist w/ Acoustic Insulation Roxul  
 AFB Resilient Channels  
 5/8" Gypsum Wall Board Finished w/  
 Zero VOC Paint (EPA AirPLUS)
- 5 **Ground Floor Assembly (Finish to Below Slab)**  
 8" Sealed Concrete Slab on Grade  
 EPS Rigid Foam Raft (R-47.6)  
 10 mil Poly Air Barrier  
 6" Compacted Gravel (EPA AirPLUS)

## 05.4 QM#1 INTEGRATION

The Harvest Home has been designed to meet the requirements for ENERGY STAR certification, as well as to meet or exceed the Quality Management provisions outlined in QM#1. The Harvest Home exceeds the 2012 IECC envelope insulation levels by 50% and exceeds the requirements for ENERGY STAR windows as indicated in Table 05.4-A.

Duct work has been designed to be installed within conditioned spaces and the Harvest Home meets the requirements for hot water distribution and indoor fixtures as outlined in the PHIUS+ Quality Control Workbook (Appendix 12). The EPA Indoor airPLUS checklist and Renewable Energy Ready Home checklist requirements have been incorporated into the design and are also further elaborated in the PHIUS+ Quality Control Workbook. For program specific checklists, refer to Section 12: Additional Documentation.

During construction of the building envelope, the Thermal Enclosure System Rater Checklist is to be completed by a third-party inspector to confirm compliance with ENERGY STAR National Program Requirements.

Table 05.4-A: 2012 IECC Building UA Compliance

Element	Insulation Levels	
	2012 IECC	As Designed
<i>Shell UA Check:</i>		
Ceilings	14.6	10
Above-Grade Walls	47.7	22.8
Windows and Doors	79.5	39
Slab Floor	2.6	0.3
Overall UA	144.4	72.1
<i>Window U-Factor Check:</i>		
Window U-Factor	0.48	0.164

NOTES: UA = U-value of element multiplied by Area of element  
For further information, refer to HERS report in Appendix 3

## 06.1 APPROACH TO IAQ

The Harvest Home is design to ensure the superior indoor air quality. The issue of air quality is addressed by first eliminating products that contaminate the interior environment followed by the filtration of fresh air and circulated air for potential contaminants and excess humidity.

Many standard products including millwork, sealants, flooring and paints contain harmful volatile organic compounds (VOCs). Typical millwork is constructed of particleboard, which gains its rigidity from glues that contain formaldehyde. For the millwork in the Harvest Home, Kirei Wheatboard (Appendix 6) has been selected due to its exceptional environmental qualities. The wheatboard product is made from wheat stalks that would otherwise be disposed of, thus reducing waste. The adhesive is a non urea-formaldehyde to ensure zero VOCs are emitted. Hardwood flooring is finished with Bona Naturale water based finish that is GREENGUARD certified for Indoor Air Quality (Appendix 6). Benjamin Moore Natura No-VOC paint (Appendix 6) is specified for application throughout the house, which emits zero VOCs and is odorless.

Many household activities generate contaminants in the air such as cooking ingredients and cleaning products. Mechanical ventilation is utilized to clean interior air when these contaminants are generated. As the house is designed to the Passive House standard, ventilation is handled year-round by the UltimateAir 200DX ERV (Appendix 7). The system is capable of moving 200 CFM of air and boasts exceptional air cleaning qualities. The filtration system eliminates pollen, mold spores and residual chemicals from cleaning supplies. The system also filters the air entering the home to ensure no outdoor pollutants enter.

## 06.2 AIR FILTRATION & VENTILATION DETAILS

The Harvest Home is designed with passive air movement strategies in mind allowing the house to be naturally ventilated in the warmer months of the year. The mechanical ventilation can be manually disabled and operable windows allow fresh air to enter the building. The roof terrace entrance with its South oriented windows and glazed door creates a stack effect, which encourages air movement through the home's central core.

### Air Filtration

- a. The Harvest Home is designed to meet the Passive House Standard for air-tightness of 0.6 ACH50, minimizing uncontrolled ventilation of the building through air leakage. This allows for effective control of indoor air quality through mechanical ventilation.
- b. The mechanical ventilation system is equipped with a MERV 12 filter, which captures 95% of particulate matter down to 1.8 microns in size.
- c. The ventilation system includes a self-balancing ERV unit, which once commissioned, will supply fresh air to rooms without creating significant pressure differences across the building envelope. Ventilation system commissioning will be conducted according to the PHIUS+ On-site Quality Control Checklist (Appendix 12), including balancing of the system to < 10% difference in flow between supply and extract air streams and  $\leq 1$  Pa maximum pressure difference between rooms with doors closed. Adhering to these standards further mitigates uncontrolled infiltration into the home.

### Ventilation System Sizing

- a. The relatively high minimum ventilation rates required to meet the Passive House Standard ensure that any contaminants resulting from cooking or material off-gassing are extracted from the indoor environment and diluted with fresh air. The ventilation delivered exceeds ASHRAE 62.2 because the system is designed to meet ventilation loads as opposed to relying on a permeable envelope to provide fresh air.
- b. The system is designed to meet the building ventilation loads, based on the greater of

either supply air requirements (18 CFM/person or 0.3 ACH) or extract air requirements (35 CFM for kitchen, 24 CFM per bathroom, and 12 CFM for powder-rooms).

- c. Ducts are sized to maintain a velocity below 600 feet per minute to mitigate noise and inefficiencies due to losses.
- d. A compact, centralized design, including minimizing the number of elbows and duct lengths contribute to minimizing duct losses, thereby increasing the efficiency of the ventilation system.

### Noise Rating

- a. Ventilation system installation will follow Passive House best practices for noise attenuation. This includes isolating the ERV unit from floor joists using dampers. Short sections of insulated flex duct are provided on both the fresh air and exhaust of the ERV unit to mitigate noise propagation through duct work. Sound-attenuating insulation is provided for all walls between the mechanical room and living spaces.
- b. The system is also designed to minimize length of duct runs and bends, reducing noise generation associated with changes in air velocity.

### Ventilation System Controls

- a. Ventilation system controls provided include boost overrides located in the kitchen and bathrooms to increase ventilation rates on demand.
- b. The main ventilation control unit includes low, medium and high settings to adjust ventilation rates as desired or required by the occupants.
- c. Carbon dioxide (CO<sub>2</sub>) sensors are located in bedrooms. These sensors are connected to the ERV control unit to boost ventilation rates if the concentration of CO<sub>2</sub> increases beyond 2000 ppm, as specified by the Passive House Standard.

For further information, refer to Section 07: Space Conditioning.

## 06.3 EPA INDOOR AIRPLUS CHECKLIST

The Harvest Home has been designed to not only meet, but exceed the EPA Indoor AirPLUS Checklist. Along with these design criteria, the home is compliant with ENERGY STAR for Homes Version 3 Guidelines and exceeds the LEED Homes Platinum standard with seven credits obtained in the Indoor Air Quality category.

### Moisture Control

The ground level concrete slab is poured atop a 6” layer of gravel to allow movement of water below the house. All floors of the home feature hard surfaces with level one comprised primarily of sealed concrete and the upper two floors of hardwood. The floors of the bath and ensuite are finished with ceramic tile and their walls are lined with water resistant gypsum wall board.

### Radon

The gravel layer below the slab also addresses radon, allowing the gas to move freely away from the underside of the home. A 10 mil poly air barrier is to be installed on the underside of the slab, ensuring no gases penetrate the concrete and entering the home’s interior. All openings in the home are to be sealed and caulked. If radon does collect beneath the slab, a vent pipe is to be installed to exhaust the gas away from the home.

### Pests

All exhaust and intake grilles feature corrosion resistant insect screens.

### HVAC Systems

The proposed UltimateAir ERV has a filter with a MERV rating of 12 and eliminates any contaminants that make their way into the home. For additional information on air filtration, ventilation or HVAC systems, refer to Section 07: Space Conditioning

### Combustion Pollutants

The home does not contain any fuel-burning appliances as heat is provided via electric baseboard heaters. Carbon monoxide detectors have been installed on each floor to ensure the home’s occupants are immediately alerted upon the detection of unsafe carbon monoxide levels.

### Materials

All millwork within the home is made of a natural wheat board - a product that contains no formaldehyde in its adhesives. All structural plywood is PS1 and PS2 compliant. The paint and water based floor finish contain no VOCs. For additional information regarding low VOC material selections, refer to Appendix 6.

## 07.1 MECHANICAL SYSTEMS PERFORMANCE GOALS

### Heating & Cooling

Due to the very low space heating and cooling requirements of the home, it would be inefficient to combine the ventilation with the heating and cooling equipment. Considering the airflow requirements for ventilation are fairly constant, whereas the heating and cooling system operation will be intermittent, the Harvest Home proposal incorporates independently operating systems.

#### Performance Objectives:

- Maintain superior thermal comfort
- Choose the most ecologically conscious energy source
- Minimize operating costs

#### Equipment Goals:

- Meet space conditioning demand with significant over sizing
- Operate efficiently by utilizing Coefficient of Performance (COP) advantages
- Minimize capital costs

### Ventilation

#### System Selection Criteria:

- Control air supply and exhaust
- Maintain healthy indoor air
- Minimize heat lost in exhaust air

Figure 07.1-A: Colorado Net Electricity Generation by Source

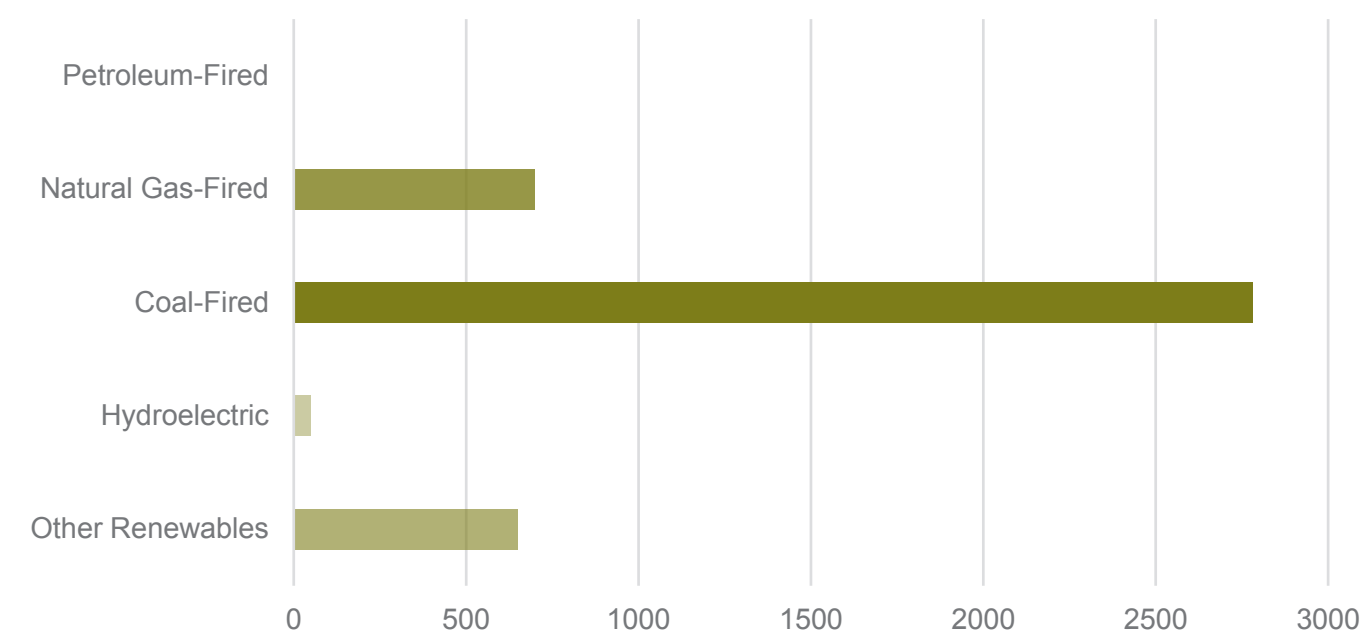

NOTE: Source: US Energy Information Agency (2014)

## 07.2 EQUIPMENT GOALS & SELECTION PROCESS

### Heating & Cooling - Equipment Selection Process

- a. Space conditioning demand governs mechanical system sizing, rendering the mechanical system a derivative of the home's envelope design. In a Passive House, the envelope requirements are based on thermal comfort criteria. For example, window U-values are selected so that there is no more than a 7 °F (4 °C) temperature difference between the interior glass surface and interior design temperature. This allows comfortable living across all floor space and eliminates the requirement for terminal units below windows. Due to the Harvest Home's high heat retention, the design effectively utilizes solar and internal gains to heat the space. To serve the drastic heating/cooling demand reduction, the house is to be conditioned by small point source supplies.
- b. A typical residential system burns natural gas on site, or draws electricity from the grid to run it. There is a misconception that electric energy is cleaner than natural gas because it does not use combustion. At the macro scale, as shown in Figure 07.1-A, Colorado's electricity supply is primarily generated through coal-firing which burns less efficiently than natural gas. Therefore, from a lifecycle perspective, grid-tied electricity actually produces greater carbon emissions than natural gas. However, the decision to utilize all-electric appliances in the project is based on the intention that the home's electricity will be harvested from on-site photovoltaic panels in the future. In this case, the electric system would produce fewer carbon emissions than natural gas alternatives.
- c. Residential HVAC contractors often oversize mechanical equipment by using systems that are similar in size to previous projects, or will drastically oversize the system to compensate for quick and inaccurate heat gain/heat loss calculations. For example, in the Canadian Standards Association publication "Determining the Required Capacity of Residential Space Heating and Cooling Equipment", it is acceptable practice to exceed the heat loss by up to 17,065 BTU/h if the total calculated building heat loss is less than 42,663 BTU/h. In the case of this project, it would be acceptable to essentially double the required heating capacity. When equipment is oversized, it tends to turn on and off at full output rather than remaining operable at a lower output rate. Full output on/off cycles reduce efficiency, reduce comfort, and can be damaging to the equipment, leading to more frequent maintenance and shorter service life.
- d. Heat pumps are able to move heat from one source to another based on the refrigeration cycle, which uses electricity to pump and compress refrigerant fluid in a manner that can output more units of heat energy than were input. For example, a heat pump with a heating COP of two would deliver two units of heat to the interior air for every one unit of heat removed from the outdoor air. Heat pumps should also be rated in SEER and EER to accommodate ENERGY STAR compliance. The same heat pump can work to heat or cool an indoor space and gain a performance advantage in both directions. However, a heat pump loses efficiency when outdoor temperatures reach extreme cold.
- e. As previously mentioned, extra investment is made in the envelope systems, thus significantly reducing interior space conditioning demands. Due to this reduced demand, a smaller, less costly system can be specified. This makes it especially critical to specify correctly sized systems. Considering less energy is required to condition the space, projected monthly utility costs are greatly reduced. The elimination of natural gas connections to the home will also result in construction cost savings.



### Heating & Cooling - Equipment Selection

Based on the room by room heat loss/gain calculations, the minimum heating capacity needed to maintain thermal comfort is 17,100 BTU/h. To meet capacity, a Mitsubishi Mr. Slim wall-mounted mini-split system is specified and configured as follows:

- 1 x MXZ-2B20NA outdoor unit
- 2 x MSZ-GE09NA wall-mounted indoor units

Backup heating with sufficient capacity to meet the peak heat load is required for when the outdoor ambient temperature is below the low temperature cut-out point of the mini-split heat pump system. The dry bulb temperature operating range for heating with the selected mini-split heat pump system is 6 °F (-14 °C) to 75 °F (24 °C). The former represents the low temperature cut-out point of the heat pump, beyond which the mini-split system is turned off and the backup electric resistance heating system is required to meet the entire heating load. Therefore, the backup heating system is sized to meet the peak heating load of 17,100 Btu/h (5 kW). Electric baseboard resistance heating units were selected for the flexibility offered in equipment sizing and installation in addition to low equipment and installation costs. Baseboard resistance heaters also consume electricity, aligning with the objective of pursuing a net-zero ready home.

To meet the backup requirements, three Dimplex LC Series Linear Convectors are to be installed - one on the main floor, and one in each of the designated bedrooms.

Meeting the 19,700 BTU/h cooling demand is not a requirement for safety, however Summer thermal comfort may not be maintained should less cooling be installed. The same mini-split heat pump has the capacity to meet this cooling demand and is also ENERGY STAR Certified.

For manufacturer's manuals of recommended equipment, refer to Appendix 7. The systems are to be installed according to the details outlined in this report, manufacturers recommendations, local building regulations and to the installing contractor's best judgement. The ENERGY STAR Version 3 installation checklist (Appendix 7) must be completed during installation.

For full operation and maintenance details for the Mitsubishi heat pump and Dimplex electric heaters, refer to Appendix 7.

## 07.2 EQUIPMENT GOALS & SELECTION PROCESS

### Ventilation - Equipment Selection Process

- a. Balanced mechanical ventilation controls the amount, location, and time of supply and exhaust air while maintaining a more neutral pressure inside the home. In a balanced ventilation system, supply ducts provide fresh outdoor air directly to living spaces and bedrooms while return ducts exhaust stale indoor air from bathrooms, kitchen, and utility rooms. By designing the envelope extremely airtight, ventilation air is supplied and exhausted through deliberate inlets and outlets in a controlled manner.
- b. Healthy indoor air mitigates pollutant concentration, eliminates odors, and controls latent moisture. An airtight envelope and direct mechanical ventilation ensures that supply air is sourced directly from the outdoors. A permeable envelope that permits significant infiltration supplies air randomly throughout exterior walls and is likely to introduce dust and mould spores. Direct exhaust from stale kitchen and bathroom air ensures that odors are not spread throughout the living spaces. The Energy Recovery Ventilator (ERV) includes an enthalpy wheel that exchanges latent moisture in the air and helps maintain desired indoor relative humidity.
- c. The ERV not only exchanges moisture, it also uses air to air heat exchange to transfer heat leaving in the exhaust air to the incoming supply air. The ERV ties together the balanced ventilation system and is responsible for significant energy savings that would otherwise be lost with direct exhaust air.

### Ventilation - Equipment Selection

The equipment selected for ventilation is the RecoupAerator 200DX ERV manufactured by UltimateAir. With over 95% heat recovery efficiency, and up to 75% moisture recovery capability, the 200DX is one of the most efficient ERVs on the market and is well-sized to meet the ventilation requirements of the Harvest Home. Good indoor air quality is maintained with 95% filtration at 1.8 microns (MERV 12), and the system is self-balancing, aiding in the prevention of pollutant infiltration through the envelope.

Refer to Appendix 7 for ERV duct layout, sizing, and flow rates. The systems are to be installed according to the details outlined in this report, manufacturer's installation guidelines, local building regulations and to the installing contractor's best judgement. The ENERGY STAR Version 3 installation checklist (Appendix 7) must be completed during installation.

For full operation and maintenance details for the RecoupAerator, refer to Appendix 7.

## 07.3 CSA SPACE CONDITIONING, VENTILATION DEMAND & EQUIPMENT SIZING

### Heat Gain/Loss Calculation

The heat loss/heat gain calculations are performed using the room by room method set in the Canadian Standards Association – CAN/CSA-F280 “Determining the Required Capacity of Residential Space Heating and Cooling Equipment”. The method follows the ASHRAE procedure to size the required space conditioning equipment for the worst case heating and cooling design temperatures, using static one dimensional heat loss/heat gain.

Table 07.3-A summarizes the heating and cooling to maintain an internal temperature of between 72 °F (22 °C) and 75 °F (24 °C). For the entire calculation document, refer to Appendix 7.

Table 07.3-A: CAN/CSA-F280 Design Conditions Summary

Section A: Design Conditions			
Heat Loss		Heat Gain	
Outdoor Design Temp Heating (°F):	-3	Outdoor Design Temp Cooling (°F):	88
Mean Soil Temp (°F):	50	Summer Mean Daily Temp Range (°F):	25
Indoor Design Temp (°F):	72	North Latitude (°N):	39
		Indoor Design Temp (°F):	75

NOTE: Designed for West end unit.

Table 07.3-B: CAN/CSA-F280 Heat Loss & Gain Summary

Section B: Heat Loss Summary		Section C: Heat Gain Summary	
Total Heat Loss (Section 21) (BTU/h):	17120.6	Total Heat Gain (Section 22) (BTU/h):	19713.9
Ventilation Heat Loss (Section 19) (BTU/h):	6480.0	Ventilation Heat Gain (Section 20) (BTU/h):	1460.2
Subtotal Heat Loss (Section 17) (BTU/h):	10640.6	Subtotal Heat Gain (Section 18) (BTU/h):	18253.7
Heated Area (ft <sup>2</sup> ):	1145.2	Cooled Area (ft <sup>2</sup> ):	1145.2

# 07.4 HVAC MECHANICAL PLANS

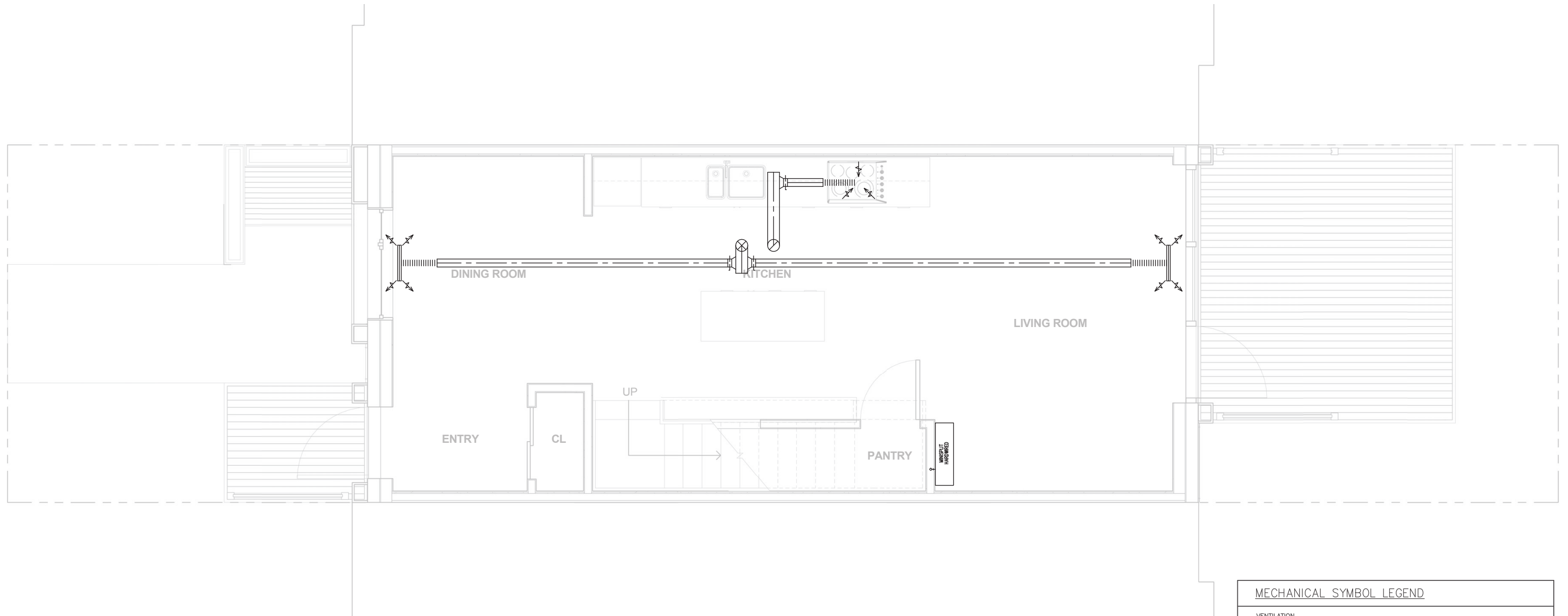

Mechanical Plan - Level One  
Scale: 1/4" = 1'-0"



MECHANICAL SYMBOL LEGEND	
VENTILATION	
	ROUND OR OVAL DUCTWORK
	LONG RADIUS ELBOW
	SUPPLY DUCTWORK UP
	SUPPLY DUCTWORK DOWN
	RETURN OR EXHAUST DUCTWORK UP
	RETURN OR EXHAUST DUCTWORK DOWN
	LINEAR DIFFUSER
	FAN CONNECTION AS SPECIFIED
	FLEXIBLE DUCTWORK
	BALANCE DAMPER
	SPIN-ON TAKEOFF WITH BALANCE DAMPER
	AIR FLOW ARROW

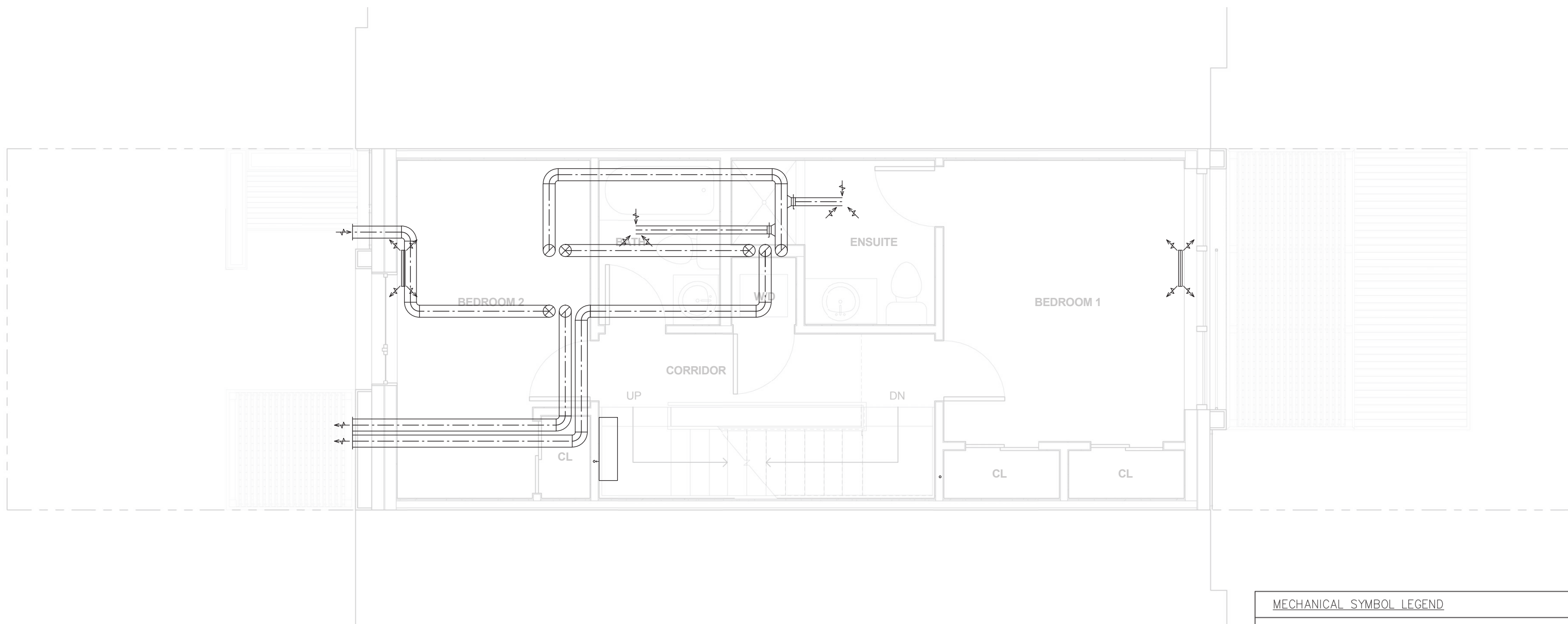

Mechanical Plan - Level Two  
Scale: 1/4" = 1'-0"



MECHANICAL SYMBOL LEGEND	
<b>VENTILATION</b>	
	ROUND OR OVAL DUCTWORK
	LONG RADIUS ELBOW
	SUPPLY DUCTWORK UP
	SUPPLY DUCTWORK DOWN
	RETURN OR EXHAUST DUCTWORK UP
	RETURN OR EXHAUST DUCTWORK DOWN
	LINEAR DIFFUSER
	FAN CONNECTION AS SPECIFIED
	FLEXIBLE DUCTWORK
	BALANCE DAMPER
	SPIN-ON TAKEOFF WITH BALANCE DAMPER
	AIR FLOW ARROW

# 07.4 HVAC MECHANICAL PLANS

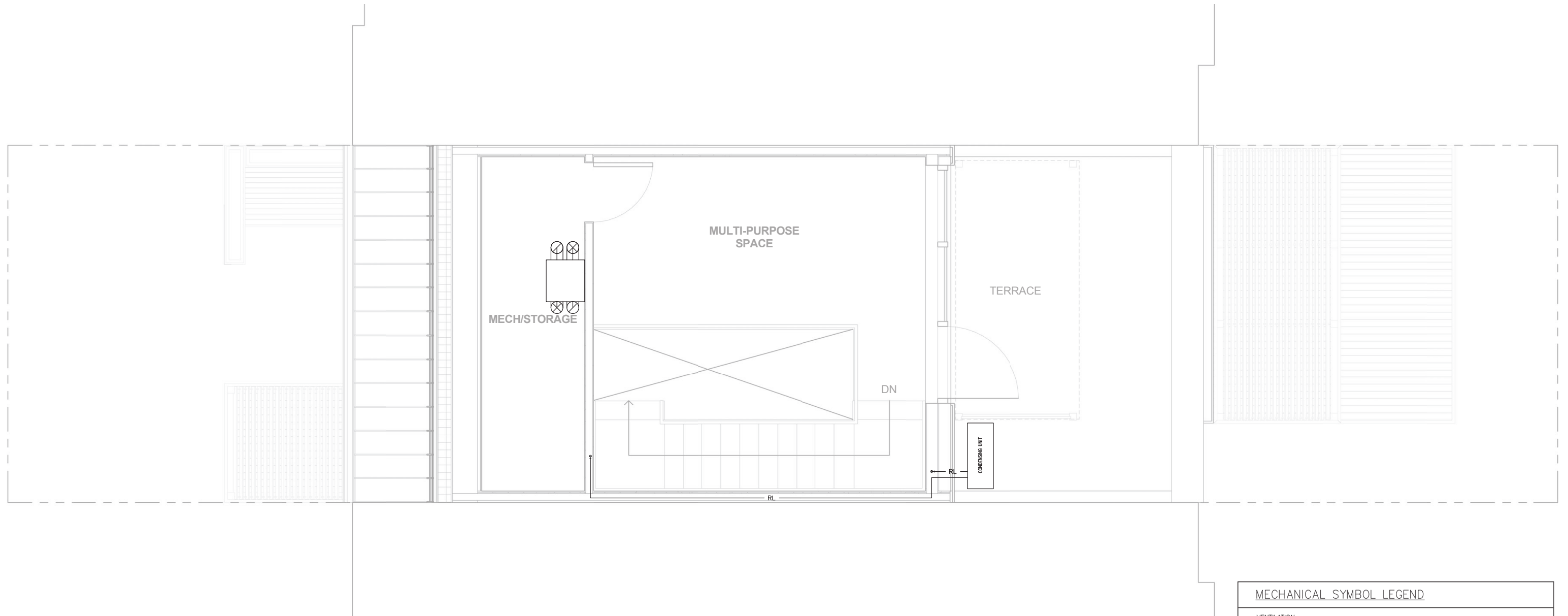

Mechanical Plan - Level Three  
Scale: 1/4" = 1'-0"



MECHANICAL SYMBOL LEGEND	
VENTILATION	
	ROUND OR OVAL DUCTWORK
	LONG RADIUS ELBOW
	SUPPLY DUCTWORK UP
	SUPPLY DUCTWORK DOWN
	RETURN OR EXHAUST DUCTWORK UP
	RETURN OR EXHAUST DUCTWORK DOWN
	LINEAR DIFFUSER
	FAN CONNECTION AS SPECIFIED
	FLEXIBLE DUCTWORK
	BALANCE DAMPER
	SPIN-ON TAKEOFF WITH BALANCE DAMPER
	AIR FLOW ARROW

## 07.5 OWNER OPERATION AND MAINTENANCE CHECKLIST

### Mitsubishi Mr. Slim Heat Pump - Maintenance

#### As Required:

- Ensure unobstructed outdoor unit air intake/exhaust

#### Bi-weekly:

- Clean Catechin air filter
- Remove dirt with vacuum
- Wash with water and let dry

#### Three Month:

- Clean Anti-Allergy Enzyme filter
- Remove dirt with vacuum
- Soak in water and let dry

#### Annually:

- Replace Anti-Allergy Enzyme Filter

### Mitsubishi Mr. Slim Heat Pump - Operation

#### Selecting Operation Mode:

- Set to AUTO mode to automatically heat and cool

#### Not in Use for Extended Period:

- Set to highest COOL mode for 3-4 hours to dry
- Press ON/OFF button
- Remove batteries from remote controller

#### Returning to Use:

- Clean air filter
- Check air inlet/outlet and outdoor unit for blockage
- Ensure ground wire is connected
- Refer to “PREPARATION BEFORE OPERATION”

### UltimateAir RecoupAerator 200DX ERV - Maintenance

#### As Required:

- Check exterior weather caps
- Dust or vacuum cabinet interior

#### Six Month:

- Check pre-filters and MERV 12 energy transfer/filtration material (filter pies) or as Check Filter light illuminates (energy 90 days of continuous operation)
- Replace filtration materials as required
- Reset Check Filter light timer
- Clean aluminum pre-filters

#### Annually:

- Check Drive Roller Belt and replace if necessary

### UltimateAir RecoupAerator 200DX ERV - Operation

- Adjust airflow as needed to maintain comfortable level of fresh air
- Wire remote ON/OFF switch or timer if constant ventilation not required
- See equipment owner’s manual for specific instruction

### Dimplex Linear Converter LC Series - Maintenance

#### As Required:

- Avoid direct contact with paper, textiles, or furniture
- Ensure unobstructed airflow
- Vacuum or remove dust by hand

#### Annually:

- Remove faceplate and eliminate dust on heat coil

### Dimplex Linear Converter LC Series - Operation

#### Selecting Operation Mode:

- ON/OFF manually to desired thermal comfort

## 08.1 DOMESTIC HOT WATER DESIGN PRINCIPLES

The design criteria for the domestic hot water system selection are:

- a. Match energy source with that of space conditioning source
- b. Meet EPA WaterSense requirements for DHW
- c. Minimize primary energy consumption
- d. Minimize capital and operating cost

### Equipment Selection Process

- a. DHW is generally heated by a combustion boiler or electric resistance. As mentioned previously, the carbon emissions of the fuel source were a primary consideration in the equipment selection process. To maintain consistency with the space conditioning source, the Harvest Home employs an electric water heater. The intent is to allow supply from on-site PV generation, consequentially eliminating the need for natural gas on site.
- b. As specified in the EPA WaterSense guidelines, the hot water delivery system shall not store more than 0.5 gallons in any piping or manifold between the source and delivery fixture. No more than 0.6 gallons of water shall be supplied before hot water is delivered from the fixture. To best accommodate this requirement, a home-run design is specified, where hot and cold water are routed through a manifold near the water heater and directly delivered to each terminal point through an individual set of PEX lines. This design uses more piping, however reduces water waste compared to typical trunk and branch systems.

- c. The longest run for hot water is from level three to the kitchen sink at the ground level. For 3 ft of 1/2" PEX, at 1.18 Oz/ft, and 28 ft of 3/8" PEX, at 0.64 Oz/ft, the maximum stored hot water, in the worst case scenario, is 21.5 ounces, or 0.17 gallons. All other plumbing lines are significantly shorter and therefore store less hot water.
- d. Passive House primary energy calculations include the energy used to heat DHW. When envelope improvements are significant, DHW contribution becomes a significant factor and may require more primary energy demand than space conditioning. Utilizing a heat-pump water heater has an efficiency advantage, as in the case of the air-source heat pump used for space conditioning, reducing total primary energy consumption.
- e. Solar hot water collection is considered as a DHW option to significantly reduce primary energy consumption. However, solar hot water systems tend to over-provide in the summer and under-provide in the winter causing an inconsistent delivery pattern relative to occupant demand. To mitigate this challenge, an additional on-demand DHW supply is required. The on-demand hot water requirement and the costly collector plates required render the solar hot water system economically inefficient. There are also additional maintenance requirements associated with solar collector systems that many homeowners tend to neglect. The water heater is located at the third floor mechanical/storage space, allowing the heat pump to draw heat from warmer air that naturally accumulates on the upper level.

For the reasons discussed above, a heat pump water heater was selected as the most suitable option considering the stipulated design criteria. Hot water is to be provided at 140 °F and 6.6 gal/person per day. The annual hot water demand is 4,900 kBTU/sf.



### **Equipment Selection**

To meet the Harvest Home's DHW demand, the design team has specified the General Electric GeoSpring hybrid water heater. To minimize standing hot water, a home-run supply design is employed, where hot and cold water are routed through a manifold near the water heater and directly delivered to each terminal point through an individual set of PEX lines. To further improve energy efficiency, the RenewABILITY Power-Pipe drain water heat recovery unit was chosen. For full operations manuals as supplied by the manufacturer, refer to Appendix 8. The systems are to be installed according to the details outlined in this report, manufacturer's recommendations, local building regulations and to the installing contractor's best judgement. The EPA WaterSense Version 1.1 installation checklist (Appendix 8) must be completed during installation.

# 08.2 PLUMBING PLANS

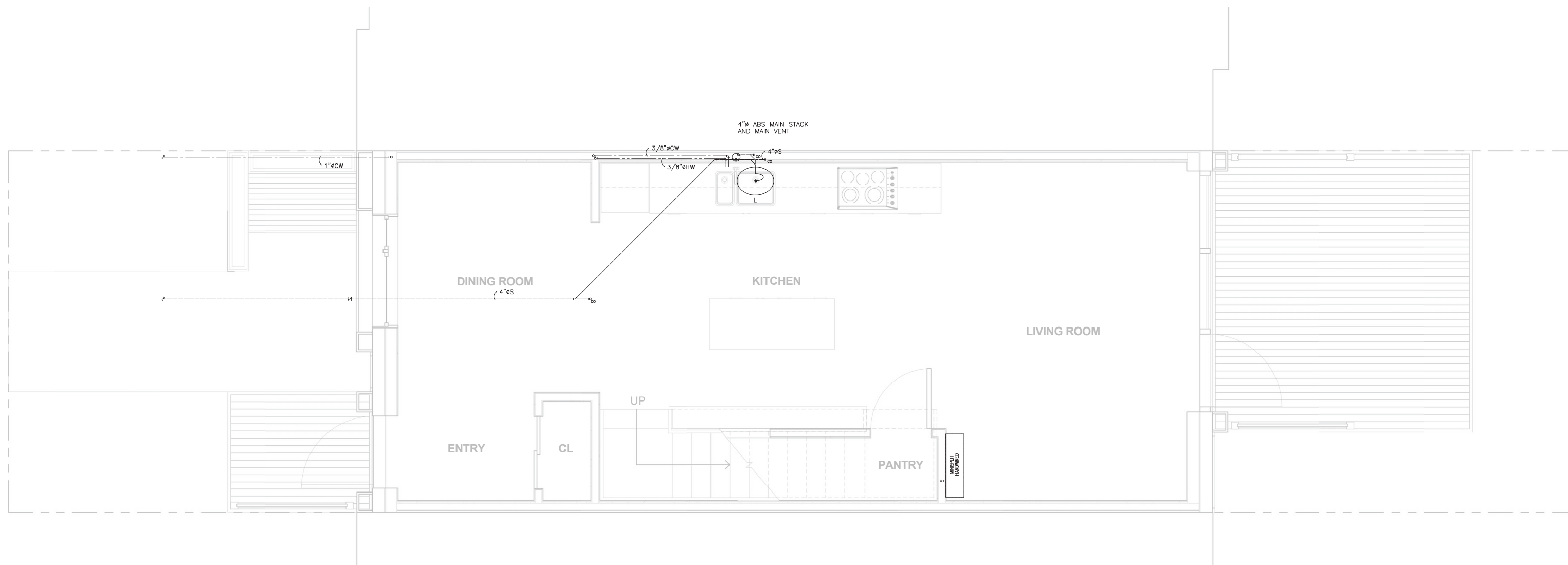

Plumbing Plan - Level One  
Scale: 1/4" = 1'-0"



PLUMBING SYMBOL LEGEND		
PLUMBING FIXTURES	PLUMBING & DRAINAGE	PIPE FITTINGS
WC FLUSH TANK TOILET L COUNTER MOUNT LAVATORY BT BATHTUB SH SHOWER	DCW — DOMESTIC COLD WATER HW — HOT WATER SANITARY (BELOW FLOOR OR BURIED) RL — LIQUID REFRIGERANT CO & — CLEANOUT PLUG CO & — CLEANOUT FLOOR U — TRAP FD & — FLOOR DRAIN	PIPE ELBOW ELBOW, UP ELBOW, DOWN PIPE TEE TEE, UP TEE, DOWN BALL VALVE CHECK VALVE BACKFLOW PREVENTER

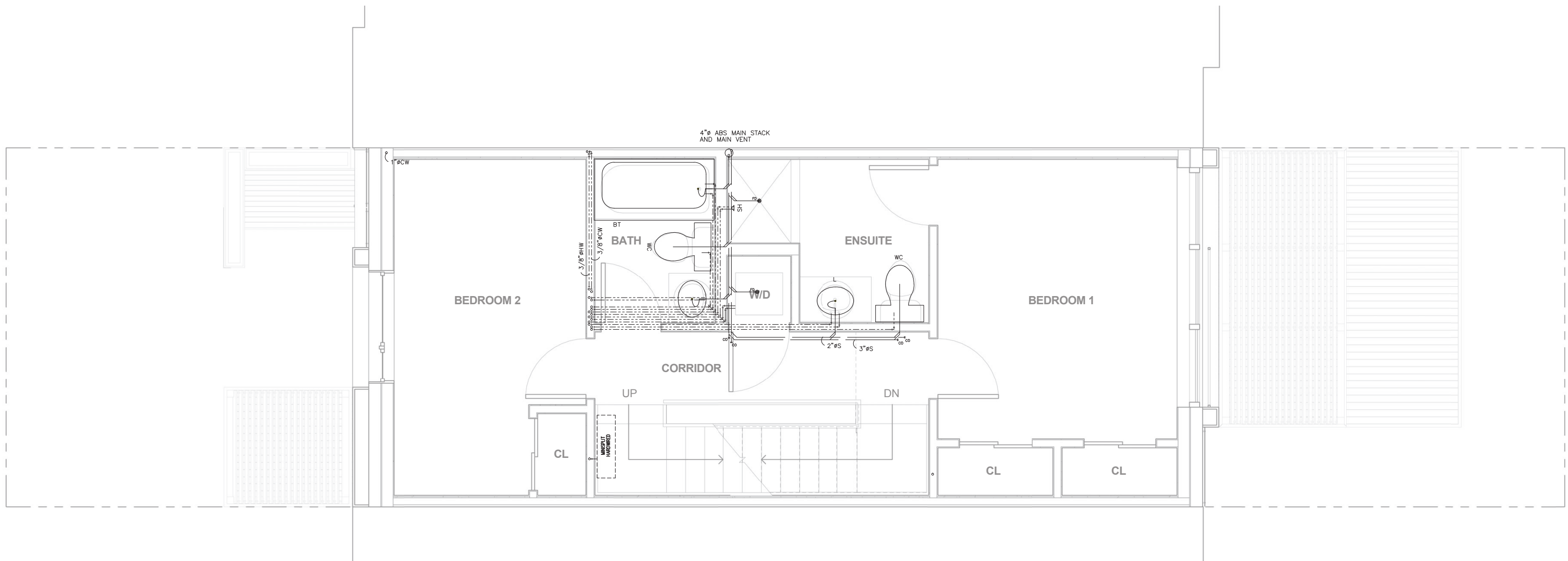

Plumbing Plan - Level Two  
Scale: 1/4" = 1'-0"



PLUMBING SYMBOL LEGEND		
PLUMBING FIXTURES	PLUMBING & DRAINAGE	PIPE FITTINGS
FLUSH TANK TOILET COUNTER MOUNT LAVATORY BATHTUB SHOWER	— DCW — DOMESTIC COLD WATER — HW — HOT WATER - - - - SANITARY (BELOW FLOOR OR BURIED) — RL — LIQUID REFRIGERANT CLEANOUT PLUG CLEANOUT FLOOR TRAP FLOOR DRAIN	PIPE ELBOW ELBOW, UP ELBOW, DOWN PIPE TEE TEE, UP TEE, DOWN BALL VALVE CHECK VALVE BACKFLOW PREVENTER

## 08.2 PLUMBING PLANS

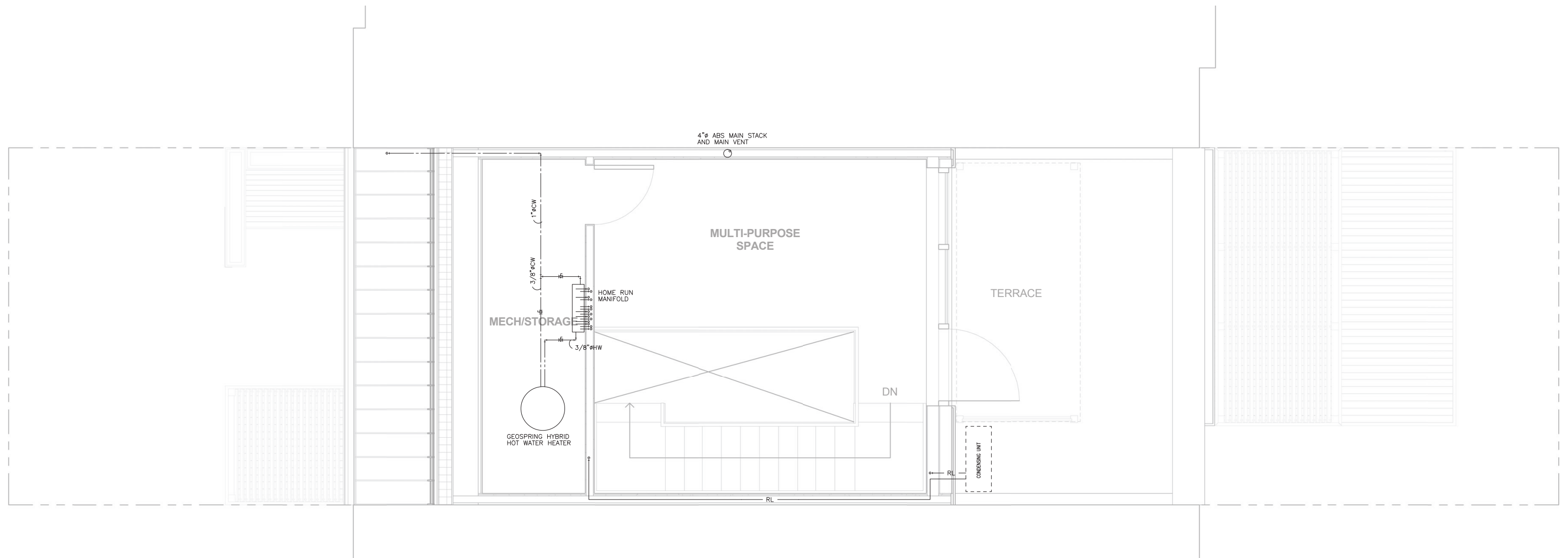

Plumbing Plan - Level Three  
Scale: 1/4" = 1'-0"



## PLUMBING SYMBOL LEGEND

PLUMBING FIXTURES	PLUMBING & DRAINAGE	PIPE FITTINGS
WC	— DCW — DOMESTIC COLD WATER	PIPE ELBOW
L	— HW — HOT WATER	ELBOW, UP
BT	- - - - SANITARY (BELOW FLOOR OR BURIED)	ELBOW, DOWN
SH	— RL — LIQUID REFRIGERANT	PIPE TEE
	CO  CLEANOUT PLUG	TEE, UP
	CO  CLEANOUT FLOOR	TEE, DOWN
	TRAP	BALL VALVE
	FD  FLOOR DRAIN	CHECK VALVE
		BACKFLOW PREVENTER

## 08.3 HOMEOWNER OPERATION & MAINTENANCE CHECKLIST

### GE GeoSpring Hybrid Electric Water Heater - Maintenance

#### As Required:

- Hand wash exterior with duster or warm water

#### Annually:

- Lift and release lever handle on temperature and pressure relief valve
- Ensure valve operates freely
- Allow several gallons to flush through discharge line into open drain
- Inspect operating controls, heating elements, and wiring (Service personnel)
- Flush water heater tank
- Clean air filter (yearly or as Filter Clean indicator appears)
- Inspect drain lines and clear any debris
- Remove and inspect anode rod if water is artificially softened (Service personnel)

#### Three Year:

- Remove and inspect anode rod (Service personnel)
- Replace anode rod when more than 6" of core wire is exposed at either end of rod

### GE GeoSpring Hybrid Electric Water Heater - Operation

#### Setting Operation Mode:

- Set to Heat Pump (only) mode
- Set temperature to 140F

#### Not in Use for Extended Period:

- Select VACATION mode
- Input total days you will be gone

#### Returning to Use:

- Unit automatically returns to use day before return

## 08.4 EPA WATERSENSE CHECKLIST

### Indoor Water Efficiency

The Harvest Home is designed to meet all criterion required by the EPA WaterSense Checklist through a plumbing design approach that minimizes water delivery distances while maintaining optimal efficiency in domestic hot water distribution throughout the home. In addition to selecting appropriate equipment, the home features a centralized plumbing stack to service the ground level kitchen, second level ensuite, laundry and bath. Additional design considerations include the provision of WaterSense labeled, low flow fixtures and ENERGY STAR qualified appliances including the dishwasher and clothes washer. For further information regarding the home's specified appliances, refer to Appendix 8.

### Outdoor Water Efficiency

The Harvest Home is host to well less than 1000 sf<sup>2</sup> of landscaped area, thus exempting the proposal from the landscape design criteria of the EPA WaterSense Checklist. Despite this exemption, the home's front yard is landscaped to retain storm water runoff. Irrigation water demand is reduced with a pair of 200 gallon cisterns - one situated at the front and one at the rear elevation. These cisterns capture rain water runoff from the roof and terrace surfaces directly from the downspouts to be used for irrigating planters at grade. Additionally, the Harvest Home employs permeable pavers along the front walkway and limits grass area to avoid extensive exposed soil at grade.

## 09.1 INTERIOR LIGHTING & APPLIANCE DESIGN APPROACH

The Harvest Home's South façade features ample glazing to increase daylight penetration to interior spaces and provide views to the surrounding context. External shading devices are located at South-oriented glazing units to reduce solar heat gains during summer months to meet strict Passive House standards. To combat overshading by these structures, the home's centralized gallery stair allows daylight to infiltrate all levels of the residence via generously sized glazing at the South terrace. Light colored wall and ceiling finishes also allow light to be reflected and, thus travelling further into the home's modest footprint.

Daylighting strategies are supplemented through the use of high efficiency light fixtures distributed throughout the home. Interior artificial lighting is designed to serve two distinct functions; firstly to provide ambient light via recessed LED pot light fixtures and secondly through carefully located task lighting.

The Harvest Home features high efficiency appliances including an ENERGY STAR certified dishwasher and clothes washer. Appliances such as the built-in oven, cook-top and range hood are designed to exceed typical ENERGY STAR performance standards, thus significantly reducing the home's annual energy consumption.

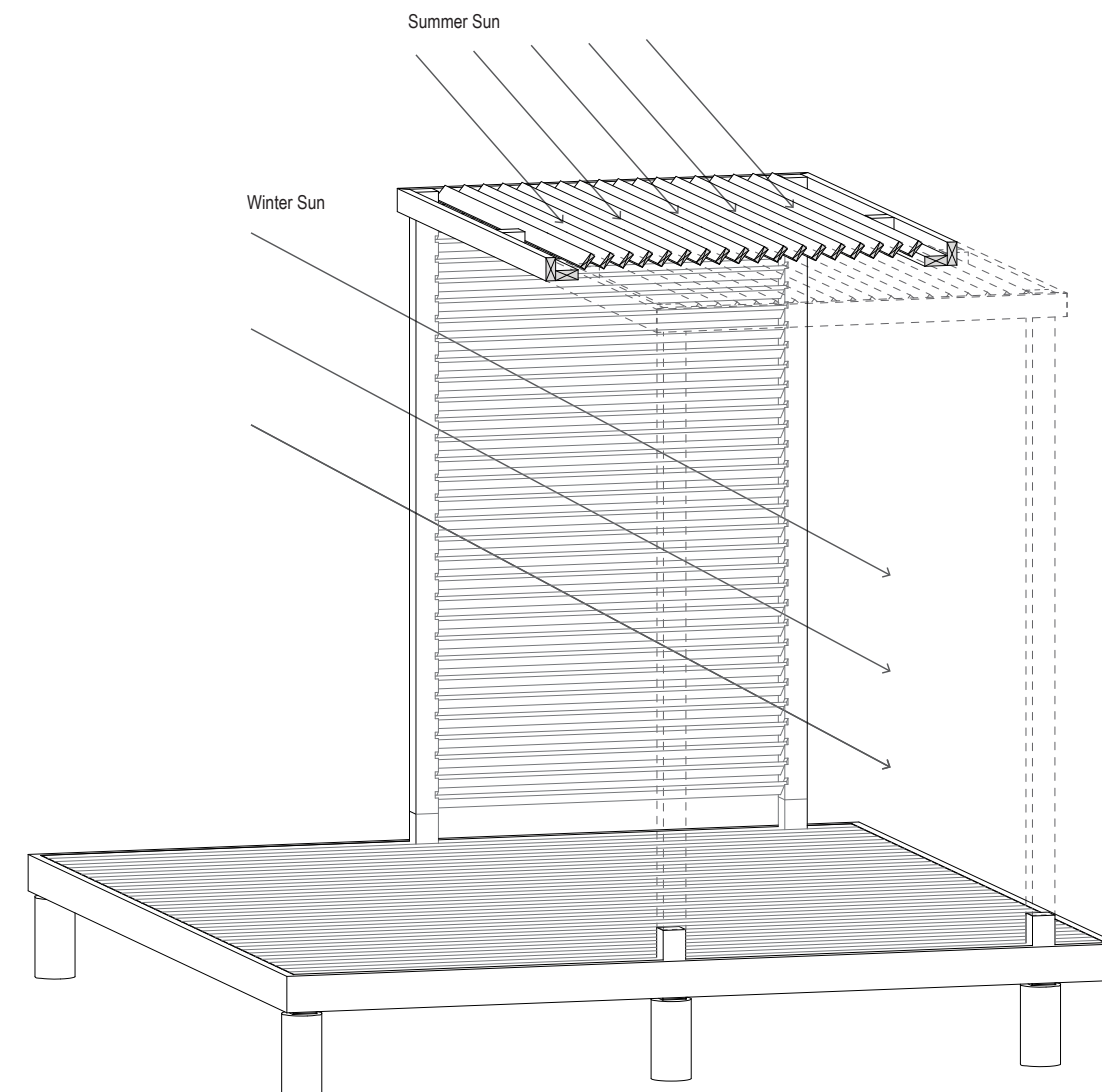

Solar-Optimized Shading Structures

## 09.2 LIGHTING ANALYSIS, AUTOMATION & MONITORING

A daylight factor analysis was done for the home with the glazing schedule and shading devices in place, providing the following values for each room which has access to a window.

Table 09.1-A: Daylight Factor Summary

Space	Daylight Factor Range	Average Daylight Factor
Living Room	2.5 - 13.4	5.23
Kitchen	0.5 - 2.6	1.54
Dining Room & Entrance	1.1 - 8.1	2.82
Bedroom #1	2.4 - 12.7	5.44
Bedroom #2	1.3 - 9.8	3.63
Upper Corridor	1.3 - 3.4	2.34
Multipurpose Space	3.4 - 20.6	6.97

Further daylighting simulation indicate that there is sufficient daylighting in the south facing rooms (living room, master bedroom and multi-purpose space) while the sun is out to eliminate the use of electrical lighting in these rooms. In spring, summer and fall, these rooms do not require electrical lighting until 7-8pm in the evening. Where electrical lighting is required, the photovoltaic system can provide renewable energy to power these fixtures.

### Winter Solstice Kitchen Example

In the morning on a non-cloudy day, the winter morning sun is low enough that daylighting penetrates deep into the house and there is sufficient daylighting in the kitchen. Around noon, supplementary light may be required for activities in the kitchen, but not all are necessary. For dinner preparations in the kitchen the ceiling potlights are required in the kitchen and supplementary lights may be turned on as necessary.

### Energy Monitoring

A Current Cost EnviR house energy monitoring system is to be installed in the breaker box to show the electricity consumption of the home for the occupants in real time. Occupants can see their electricity consumption on the display unit, on their computer and even on their mobile device so they may take a conscious effort to reduce their consumption and track the changes. The EnviR also has the capabilities of monitoring the energy consumption of major appliances for occupants to understand where the electricity is predominantly used.

# 09.3 HARDWIRING LIGHT PLANS

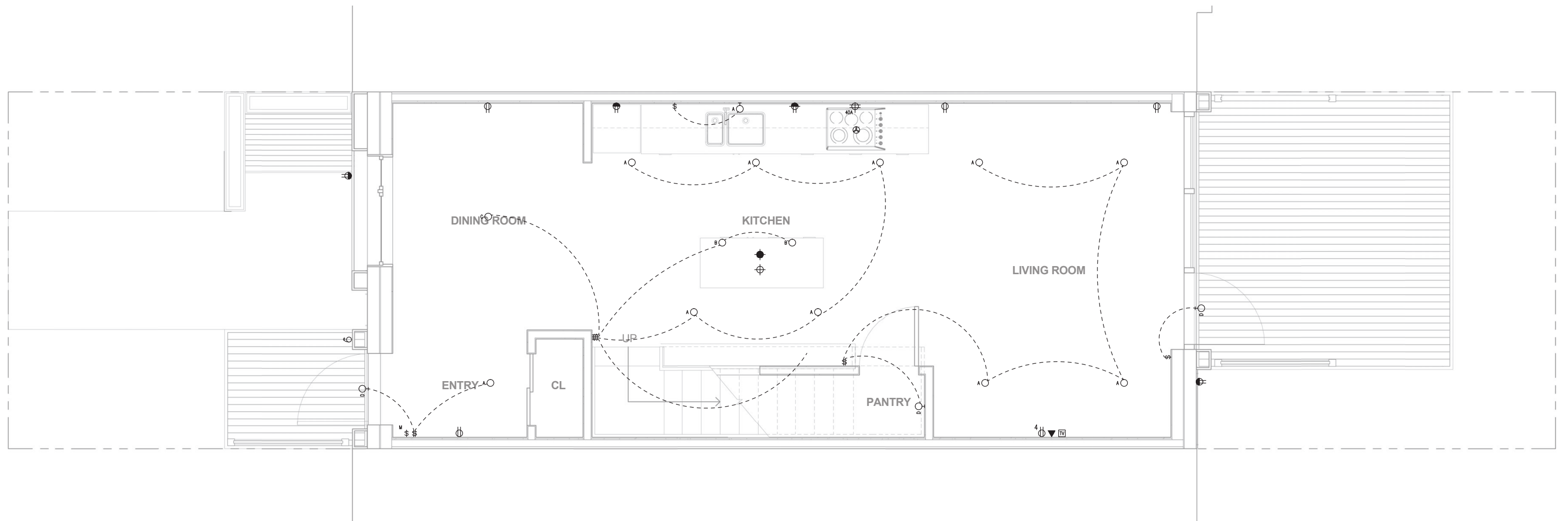

Electrical Plan - Level One  
Scale: 1/4" = 1'-0"



ELECTRICAL SYMBOL LEGEND			
<p><b>GENERAL POWER</b></p> <ul style="list-style-type: none"> <li>⊕ 15A, U-GROUND SINGLE RECEPTACLE</li> <li>⊕⊕ 15A, U-GROUND DUPLEX RECEPTACLE 4 INDICATES QUAD RECEPTACLE (DOUBLE DUPLEX)</li> <li>⊕⊕⊕ 15A, U-GROUND SINGLE OR DUPLEX RECEPTACLE MOUNTED ABOVE COUNTER OR 1200AFF</li> <li>⊕⊕⊕⊕ 15A, U-GROUND SINGLE INSULATED/ISOLATED GROUND RECEPTACLE - STANDARD MOUNTING HEIGHT OR MOUNTED ABOVE COUNTER OR 1200AFF</li> <li>⊕⊕⊕⊕⊕ 15A, U-GROUND DUPLEX INSULATED/ISOLATED GROUND RECEPTACLE - STANDARD MOUNTING HEIGHT OR MOUNTED ABOVE COUNTER OR 1200AFF</li> <li>⊕⊕⊕⊕⊕⊕ 120/208V/16/30 AMP DRYER OUTLET</li> <li>⊕⊕⊕⊕⊕⊕⊕ 120/208V/16/40 AMP RANGE OUTLET</li> </ul>	<p><b>LIGHTING</b></p> <ul style="list-style-type: none"> <li>⊕⊕⊕⊕⊕⊕ CEILING MOUNTED LUMINAIRE, PHILIPS LIGHTOWER CORE PRO LED (CP630K6)</li> <li>⊕⊕⊕⊕⊕⊕ CEILING MOUNTED LUMINAIRE, ACCESS LIGHTING INARI SILK CYLINDER PENDANT (S4932 LED 4 BS OPL) (72932 LED 4 BS OPL)</li> <li>⊕⊕⊕⊕⊕⊕ CEILING MOUNTED LUMINAIRE, ACCESS LIGHTING NITROGEN BALL PENDANT (23952)</li> <li>⊕⊕⊕⊕⊕⊕ CEILING MOUNTED LUMINAIRE, PHILIPS GLASSLITE (CAMRGD)</li> <li>⊕⊕⊕⊕⊕⊕ WALL MOUNTED LUMINAIRE, BROWNLEE TASK UTILITY (5080 48 32L ES4) (5020 24 CEC 217L WA ESS)</li> <li>⊕⊕⊕⊕⊕⊕ WALL MOUNTED LUMINAIRE, BROWNLEE BATH AND VANITY UTILITY (5020 24 CEC 217L WA ESS)</li> <li>⊕⊕⊕⊕⊕⊕ WALL MOUNTED LUMINAIRE, BROWNLEE BATH AND VANITY UTILITY (5020 36 CEC 225L WA ESS)</li> <li>⊕⊕⊕⊕⊕⊕ WALL MOUNTED LUMINAIRE, ACCESS LIGHTING BRICK WET LOCATION (20450)</li> </ul>	<p><b>LIGHTING CONTROL</b></p> <ul style="list-style-type: none"> <li>⊕⊕⊕⊕⊕⊕ ONE, TWO, THREE AND FOUR GANG SINGLE POLE TOGGLE SWITCHES</li> <li>⊕ 3-WAY SWITCH</li> <li>⊕* MASTER SWITCH</li> </ul> <p><b>FIRE ALARM SYSTEM</b></p> <ul style="list-style-type: none"> <li>⊕⊕⊕⊕⊕⊕ SMOKE DETECTOR - WALL OR CEILING MOUNTED</li> <li>⊕⊕⊕⊕⊕⊕ CARBON MONOXIDE DETECTOR - WALL OR CEILING MOUNTED</li> </ul> <p><b>EQUIPMENT CONNECTIONS AND CONTROLS</b></p> <ul style="list-style-type: none"> <li>⊕⊕⊕⊕⊕⊕ FAN CONNECTION AS SPECIFIED</li> </ul>	<p><b>COMMUNICATIONS</b></p> <ul style="list-style-type: none"> <li>⊕⊕⊕⊕⊕ TELEVISION OUTLET - WALL MOUNTED OR MOUNTED ABOVE COUNTER</li> <li>⊕⊕⊕⊕⊕ TELEPHONE OUTLET - WALL MOUNTED OR MOUNTED ABOVE COUNTER</li> <li>⊕⊕⊕⊕⊕ DATA OUTLET - WALL MOUNTED OR MOUNTED ABOVE COUNTER</li> <li>⊕⊕⊕⊕⊕ SIGNAL BELL C/W TRANSFORMER</li> </ul>



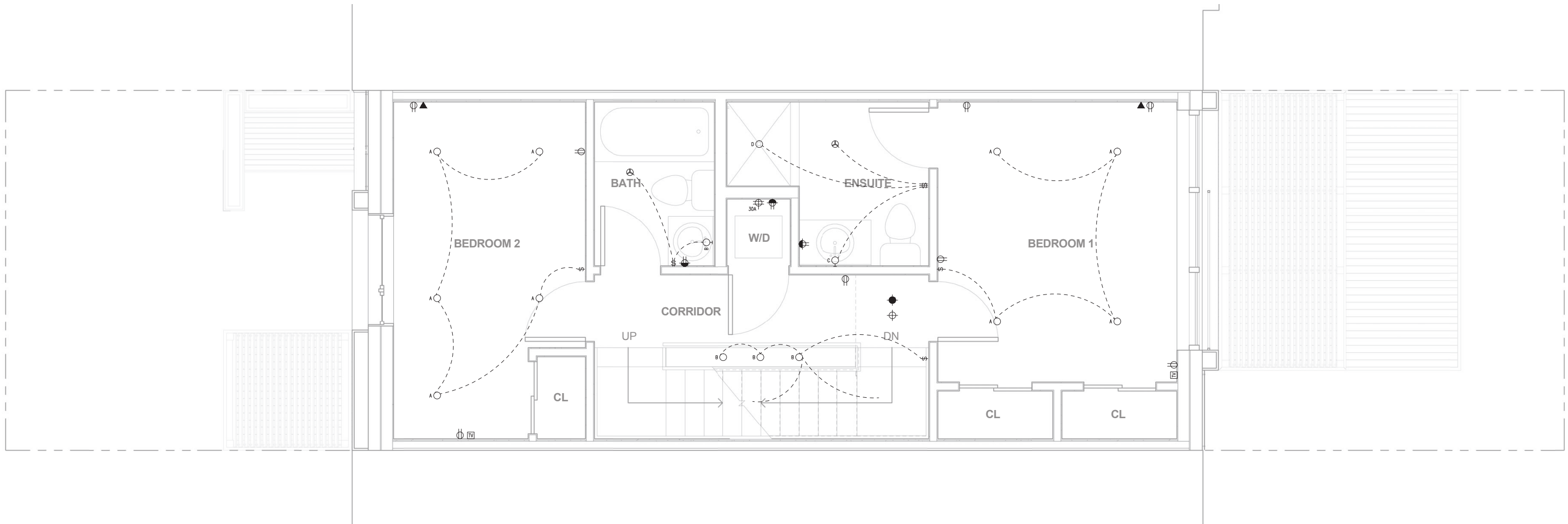

Electrical Plan - Level Two  
Scale: 1/4" = 1'-0"



ELECTRICAL SYMBOL LEGEND			
GENERAL POWER	LIGHTING	LIGHTING CONTROL	COMMUNICATIONS
<ul style="list-style-type: none"> <li>⊕ 15A, U-GROUND SINGLE RECEPTACLE</li> <li>⊕⊕ 15A, U-GROUND DUPLEX RECEPTACLE</li> <li>⊕⊕⊕ 4 INDICATES QUAD RECEPTACLE (DOUBLE DUPLEX)</li> <li>⊕⊕ 15A, U-GROUND SINGLE OR DUPLEX RECEPTACLE MOUNTED ABOVE COUNTER OR 1200AFF</li> <li>⊕⊕⊕ 15A, U-GROUND SINGLE INSULATED/ISOLATED GROUND RECEPTACLE - STANDARD MOUNTING HEIGHT OR MOUNTED ABOVE COUNTER OR 1200AFF</li> <li>⊕⊕⊕ 15A, U-GROUND DUPLEX INSULATED/ISOLATED GROUND RECEPTACLE - STANDARD MOUNTING HEIGHT OR MOUNTED ABOVE COUNTER OR 1200AFF</li> <li>⊕⊕⊕ 120/208V/16/30 AMP DRYER OUTLET</li> <li>⊕⊕⊕ 120/208V/16/40 AMP RANGE OUTLET</li> </ul>	<ul style="list-style-type: none"> <li>⊕⊕⊕⊕ CEILING MOUNTED LUMINAIRE, PHILIPS LIGHTOWER CORE PRO LED (CP630K6)</li> <li>⊕⊕⊕⊕ CEILING MOUNTED LUMINAIRE, ACCESS LIGHTING INARI SILK CYLINDER PENDANT (94932 LED 4 BS OPL) (72932 LED 4 BS OPL)</li> <li>⊕⊕⊕⊕ CEILING MOUNTED LUMINAIRE, ACCESS LIGHTING NITROGEN BALL PENDANT (23952)</li> <li>⊕⊕⊕⊕ CEILING MOUNTED LUMINAIRE, PHILIPS GLASSLITE (CAMRD)</li> <li>⊕⊕⊕⊕ WALL MOUNTED LUMINAIRE, BROWNLEE TASK UTILITY (5080 48 32L E54) (5020 24 CEC 217L WA ESS)</li> <li>⊕⊕⊕⊕ WALL MOUNTED LUMINAIRE, BROWNLEE BATH AND VANITY UTILITY (5020 24 CEC 217L WA ESS)</li> <li>⊕⊕⊕⊕ WALL MOUNTED LUMINAIRE, BROWNLEE BATH AND VANITY UTILITY (5020 36 CEC 225L WA ESS)</li> <li>⊕⊕⊕⊕ WALL MOUNTED LUMINAIRE, ACCESS LIGHTING BRICK WET LOCATION (20450)</li> </ul>	<ul style="list-style-type: none"> <li>⊕⊕⊕⊕ ONE, TWO, THREE AND FOUR GANG SINGLE POLE TOGGLE SWITCHES</li> <li>⊕ 3-WAY SWITCH</li> <li>⊕ MASTER SWITCH</li> </ul> <p><b>FIRE ALARM SYSTEM</b></p> <ul style="list-style-type: none"> <li>⊕⊕⊕⊕ SMOKE DETECTOR - WALL OR CEILING MOUNTED</li> <li>⊕⊕⊕⊕ CARBON MONOXIDE DETECTOR - WALL OR CEILING MOUNTED</li> </ul> <p><b>EQUIPMENT CONNECTIONS AND CONTROLS</b></p> <ul style="list-style-type: none"> <li>⊕⊕⊕⊕ FAN CONNECTION AS SPECIFIED</li> </ul>	<ul style="list-style-type: none"> <li>⊕⊕⊕ TELEVISION OUTLET - WALL MOUNTED OR MOUNTED ABOVE COUNTER</li> <li>⊕⊕⊕ TELEPHONE OUTLET - WALL MOUNTED OR MOUNTED ABOVE COUNTER</li> <li>⊕⊕⊕ DATA OUTLET - WALL MOUNTED OR MOUNTED ABOVE COUNTER</li> <li>⊕ SIGNAL BELL C/W TRANSFORMER</li> </ul>

# 09.3 HARDWIRING LIGHT PLANS

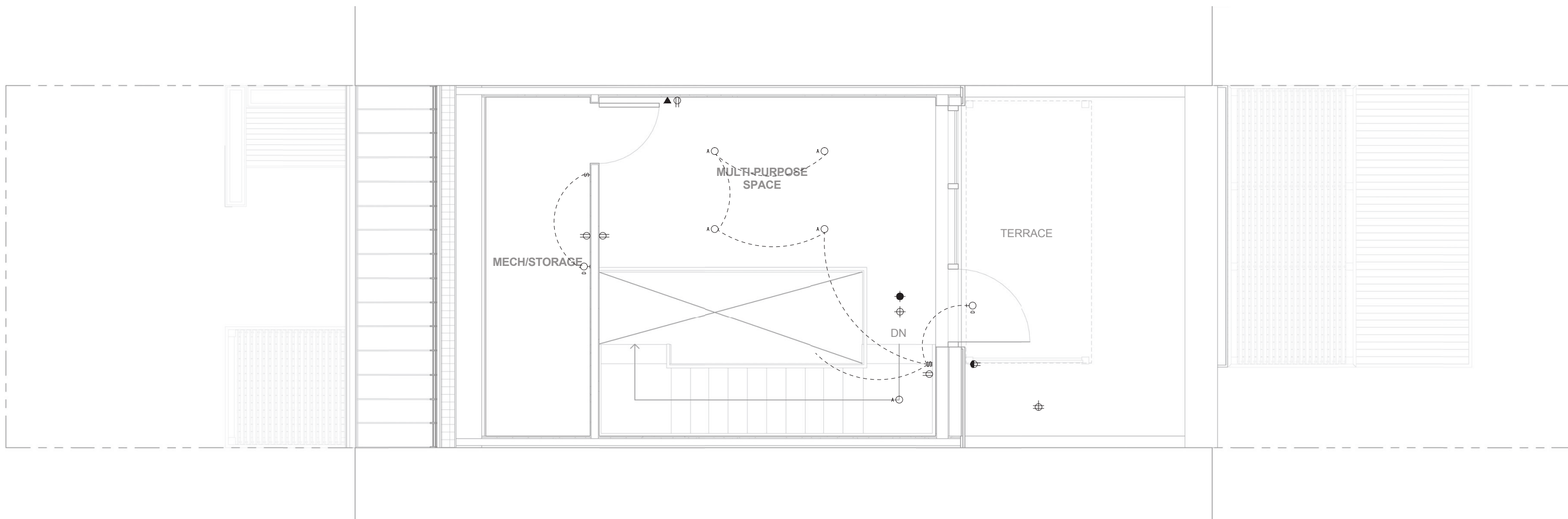

Electrical Plan - Level One  
Scale: 1/4" = 1'-0"



ELECTRICAL SYMBOL LEGEND			
GENERAL POWER	LIGHTING	LIGHTING CONTROL	COMMUNICATIONS
<ul style="list-style-type: none"> <li>⊕ 15A, U-GROUND SINGLE RECEPTACLE</li> <li>⊕⊕ 15A, U-GROUND DUPLEX RECEPTACLE 4 INDICATES QUAD RECEPTACLE (DOUBLE DUPLEX)</li> <li>⊕⊕⊕ 15A, U-GROUND SINGLE OR DUPLEX RECEPTACLE MOUNTED ABOVE COUNTER OR 1200AFF</li> <li>⊕⊕⊕⊕ 15A, U-GROUND SINGLE INSULATED/ISOLATED GROUND RECEPTACLE - STANDARD MOUNTING HEIGHT OR MOUNTED ABOVE COUNTER OR 1200AFF</li> <li>⊕⊕⊕⊕ 15A, U-GROUND DUPLEX INSULATED/ISOLATED GROUND RECEPTACLE - STANDARD MOUNTING HEIGHT OR MOUNTED ABOVE COUNTER OR 1200AFF</li> <li>⊕⊕⊕⊕⊕ 120/208V/16/30 AMP DRYER OUTLET</li> <li>⊕⊕⊕⊕⊕ 120/208V/16/40 AMP RANGE OUTLET</li> </ul>	<ul style="list-style-type: none"> <li>⊕⊕⊕⊕⊕ CEILING MOUNTED LUMINAIRE, PHILIPS LIGHTOWER CORE PRO LED (CP630K6)</li> <li>⊕⊕⊕⊕⊕ CEILING MOUNTED LUMINAIRE, ACCESS LIGHTING INARI SILK CYLINDER PENDANT (94932 LED 4 BS OPL) (72932 LED 4 BS OPL)</li> <li>⊕⊕⊕⊕⊕ CEILING MOUNTED LUMINAIRE, ACCESS LIGHTING NITROGEN BALL PENDANT (23952)</li> <li>⊕⊕⊕⊕⊕ CEILING MOUNTED LUMINAIRE, PHILIPS GLASSLITE (CAMRG)</li> <li>⊕⊕⊕⊕⊕ WALL MOUNTED LUMINAIRE, BROWNLEE TASK UTILITY (5080 48 32L ES4) (5020 24 CEC 217L WA ESS)</li> <li>⊕⊕⊕⊕⊕ WALL MOUNTED LUMINAIRE, BROWNLEE BATH AND VANITY UTILITY (5020 24 CEC 217L WA ESS)</li> <li>⊕⊕⊕⊕⊕ WALL MOUNTED LUMINAIRE, BROWNLEE BATH AND VANITY UTILITY (5020 36 CEC 225L WA ESS)</li> <li>⊕⊕⊕⊕⊕ WALL MOUNTED LUMINAIRE, ACCESS LIGHTING BRICK WET LOCATION (20450)</li> </ul>	<ul style="list-style-type: none"> <li>⊕⊕⊕⊕⊕ ONE, TWO, THREE AND FOUR GANG SINGLE POLE TOGGLE SWITCHES</li> <li>⊕⊕⊕⊕⊕ 3-WAY SWITCH</li> <li>⊕⊕⊕⊕⊕ MASTER SWITCH</li> </ul> <p><b>FIRE ALARM SYSTEM</b></p> <ul style="list-style-type: none"> <li>⊕⊕⊕⊕⊕ SMOKE DETECTOR - WALL OR CEILING MOUNTED</li> <li>⊕⊕⊕⊕⊕ CARBON MONOXIDE DETECTOR - WALL OR CEILING MOUNTED</li> </ul> <p><b>EQUIPMENT CONNECTIONS AND CONTROLS</b></p> <ul style="list-style-type: none"> <li>⊕⊕⊕⊕⊕ FAN CONNECTION AS SPECIFIED</li> </ul>	<ul style="list-style-type: none"> <li>⊕⊕⊕⊕⊕ TELEVISION OUTLET - WALL MOUNTED OR MOUNTED ABOVE COUNTER</li> <li>⊕⊕⊕⊕⊕ TELEPHONE OUTLET - WALL MOUNTED OR MOUNTED ABOVE COUNTER</li> <li>⊕⊕⊕⊕⊕ DATA OUTLET - WALL MOUNTED OR MOUNTED ABOVE COUNTER</li> <li>⊕⊕⊕⊕⊕ SIGNAL BELL C/W TRANSFORMER</li> </ul>

## 09.4 WORK SURFACE LIGHT DESIGN

To ensure optimal occupant comfort while minimizing resource consumption, lighting simulation studies are performed throughout the design process based on specified fixtures, locations and spatial organizations. Task-specific lighting is provided throughout the home and is supplemented by high efficiency recessed pot-lights.

The graphics shown inset indicate illumination gradients on the work surfaces at each room with dedicated light fixtures to illuminate each area. Specific illumination levels are provided to demonstrate the minimum and maximum illumination levels throughout the work surfaces at each room.

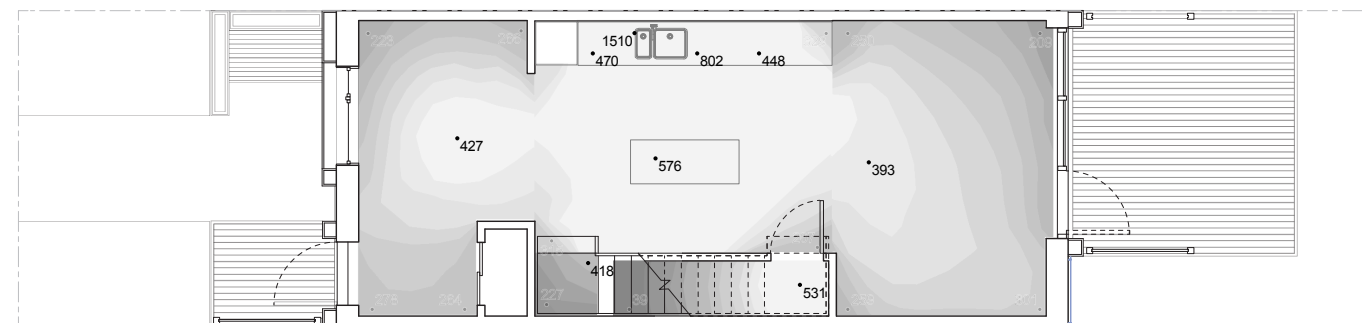
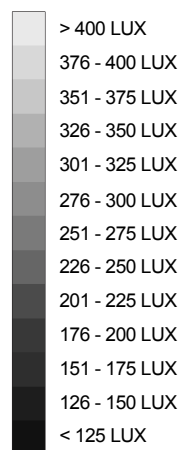

Surface Illumination Gradients - Level One

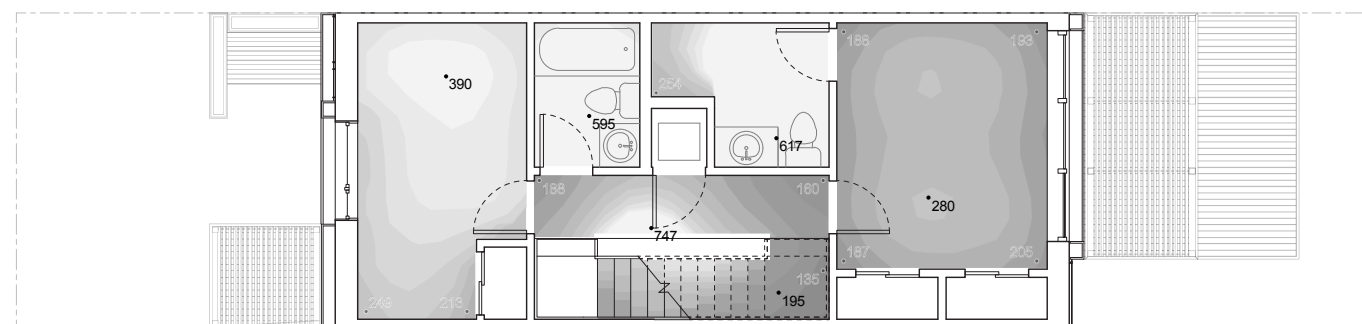

Surface Illumination Gradients - Level Two



Surface Illumination Gradients - Level Three

## 09.5 APPLIANCE PLAN

The appliances featured in the Harvest Home are selected based on both affordability and efficiency parameters. Compact appliances are specified not only for their space saving qualities, but are also appropriately sized for the floor plate and number of occupants in the home. The home's refrigerator, dishwasher and clothes washer are ENERGY STAR certified products.

Table 09.5-A: Appliance Schedule

Appliance	Manufacturer	Model	Energy Use	Cost	ENERGY STAR	Label
<b>Kitchen Appliances</b>						
Cooktop	Miele	KM5621	235 kWh/yr	\$1,199	N/A	A
Oven	Whirlpool	WOS52EMB	197 kWh/yr	\$1,399	N/A	B
Refrigerator	Moffat	MBC12GAZBB	389 kWh/yr	\$899	Yes	C
Dishwasher	Blomberg	DWS54100	210 kWh/yr	\$810	Yes	D
<b>Laundry Appliances</b>						
Washer	Blomberg	WM87120NBL00	173 kWh/yr	\$1,059	Yes	E
Dryer	Blomberg	DV17540NL00	379 kWh/yr	\$699	N/A	F

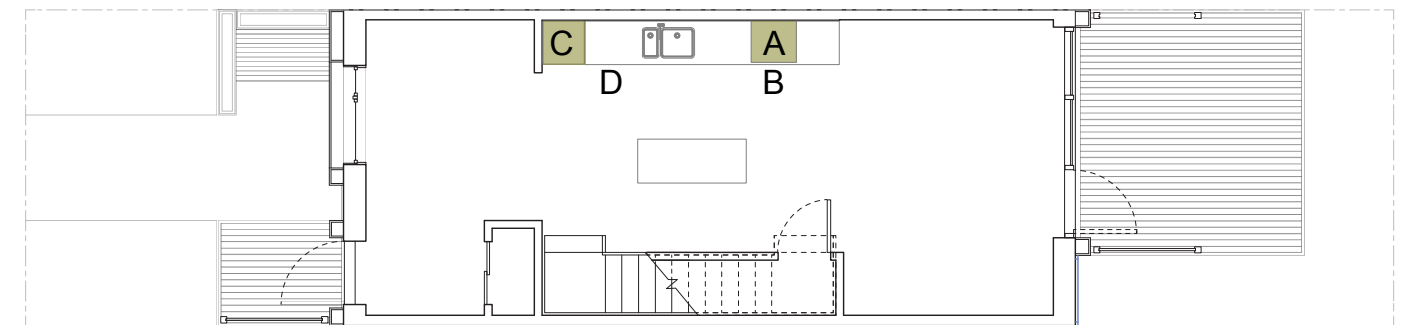

Surface Illumination Gradients - Level One

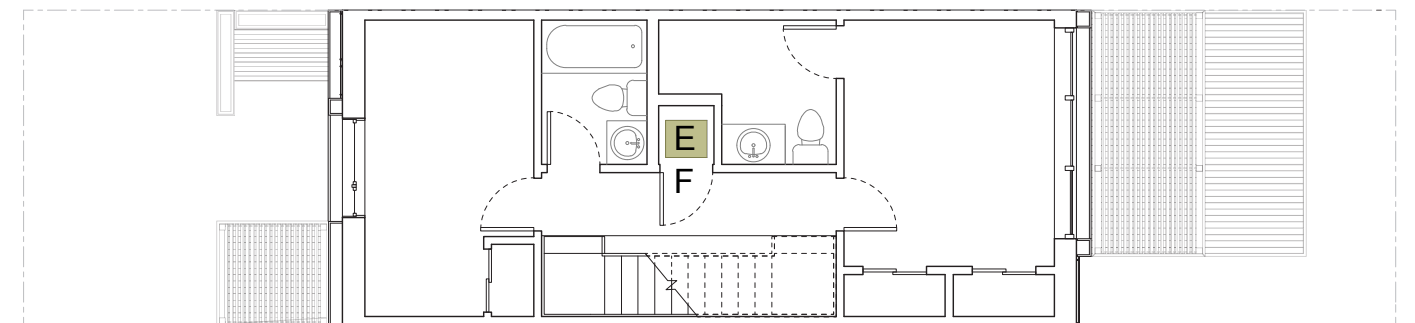

Surface Illumination Gradients - Level Two

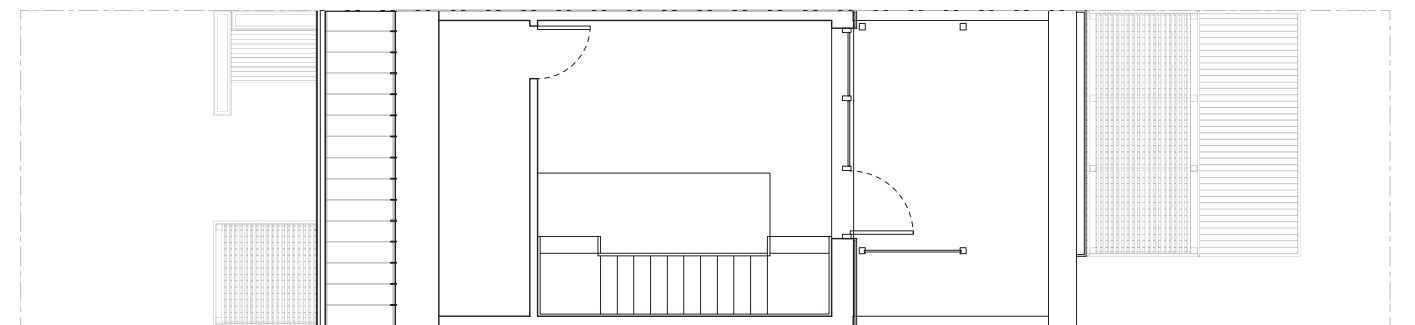

Surface Illumination Gradients - Level Three

## 09.6 LOAD MANAGEMENT PLAN

Steps were taken to first reduce the electricity load by harvesting the daylighting energy from the sun. Then light fixtures and appliances were chosen for their high efficiency and low wattage, the majority of them being Energy Star certified, to minimize the load of required lighting and appliances. The outdoor backyard porch light is motion activated with an integral photocell to provide lighting needs at night when necessary. Light fixtures and appliances that use electricity efficiently have been included in this home, but the occupants themselves must use these products effectively to take full advantage of their energy efficient quality.

### **All-off switch**

An all-off switch situated at the home's front entry turns off any lights that were left on (excluding security lights) and control the electricity flow to certain outlets in the home to reduce the plug load while the home is not occupied. Occupants can rest assure that their home is using the least amount of electricity while it is not being occupied. Appliances such as the refrigerator and some outlets in the home will be unaffected by this switch to allow for some devices to continue to operate.

The use of the all-off switch in combination with the monitoring system will help occupants quantify the amount of electricity each electronic device uses and how much electricity is consumed by devices that are simply plugged in and not in use.

### **Occupant education**

Beyond the two above features of the house, we would like to outline electricity saving measures that can be taken by the occupants so that they may use their home as efficiently as possible – how we intend it to be occupied. We would also like to encourage the occupants to adjust their energy and water intensive activities to fall during off-peak hours to reduce the peak loads of service providers while saving money on their utility bills.

## 10.1 RENEWABLE ENERGY SYSTEMS

The Passive House modeling shows an annual total energy consumption of approximately 3800 kWh per year. The photovoltaic potential for the proposed roof is 3010kWh per year bringing the home very close to Net Zero Energy ready. These calculations are set to utilize market standard photovoltaic panels at 15% efficiency. Therefore, a slight efficiency increase in photovoltaic technology will render the Harvest Home Net Zero Energy.

Although flat photovoltaic arrays do accumulate more snow than a tilted alternative, the solar collection provided during the winter months is not as considerable as that during the warmer season. The possibility to generate more electricity throughout the year is a priority for the project.

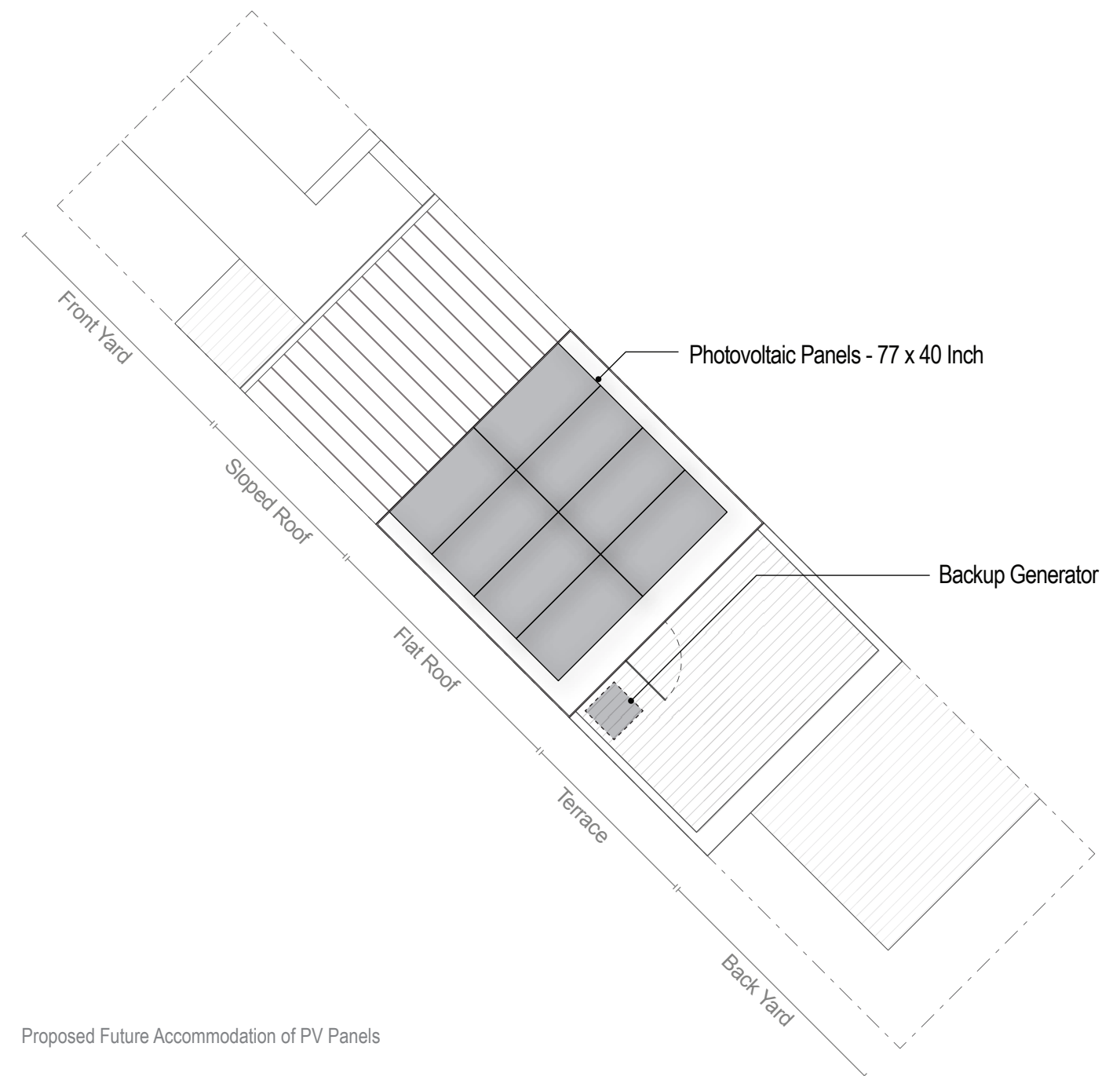

# 10.2 FINANCIAL LIFECYCLE ANALYSIS

To derive the financial lifecycle analysis for the proposed photovoltaic array, the team assumed a PV production of 3000kWh per year. The analysis indicates a positive cash flow at the tenth year of operation, in addition to a positive cash flow return of \$15,500 over the subsequent 15 years of operation.

Table 10.2-A: Photovoltaic Panel Energy Calculations

Month	Solar Radiation kWh/m2/day	AC Energy kWh	Energy Value \$
January	2.60	141	12
February	3.51	174	15
March	4.73	267	24
April	5.66	302	27
May	6.60	351	31
June	7.46	372	33
July	7.17	358	32
August	6.02	311	27
September	5.37	272	24
October	3.82	203	18
November	2.74	141	12
December	2.24	117	10
<b>Annual Total</b>	<b>4.83</b>	<b>3,010</b>	<b>\$266</b>

NOTE: Weather data for Denver, CO from National Renewable Energy Lab (NREL)

Table 10.2-B: Photovoltaic Lifecycle Costing

Year	Solar Energy Credit	Tax Credit	Utility Savings	Annual Cash flow	Cumulative Cashflow
Gross Cost - \$10,888					
0	\$ -	\$ 3,266.00	\$ -	\$ (7,622.00)	\$ (7,622.00)
1	\$ 150.00	\$ -	\$ 569.00	\$ 719.00	\$ (6,903.00)
2	\$ 150.00	\$ -	\$ 590.00	\$ 740.00	\$ (6,163.00)
3	\$ 150.00	\$ -	\$ 613.00	\$ 763.00	\$ (5,400.00)
4	\$ 150.00	\$ -	\$ 636.00	\$ 786.00	\$ (4,614.00)
5	\$ 150.00	\$ -	\$ 660.00	\$ 810.00	\$ (3,804.00)
6	\$ 150.00	\$ -	\$ 685.00	\$ 835.00	\$ (2,969.00)
7	\$ 150.00	\$ -	\$ 711.00	\$ 861.00	\$ (2,108.00)
8	\$ 150.00	\$ -	\$ 738.00	\$ 888.00	\$ (1,220.00)
9	\$ 150.00	\$ -	\$ 766.00	\$ 916.00	\$ (304.00)
10	\$ 150.00	\$ -	\$ 794.00	\$ 944.00	\$ 640.00
11	\$ 150.00	\$ -	\$ 825.00	\$ 825.00	\$ 1,465.00
12	\$ 150.00	\$ -	\$ 856.00	\$ 856.00	\$ 2,321.00
13	\$ 150.00	\$ -	\$ 888.00	\$ 888.00	\$ 3,209.00
14	\$ 150.00	\$ -	\$ 922.00	\$ 922.00	\$ 4,131.00
15	\$ 150.00	\$ -	\$ 956.00	\$ (493.00)	\$ 3,638.00
16	\$ 150.00	\$ -	\$ 993.00	\$ 993.00	\$ 4,631.00
17	\$ 150.00	\$ -	\$ 1,030.00	\$ 1,030.00	\$ 5,661.00
18	\$ 150.00	\$ -	\$ 1,069.00	\$ 1,069.00	\$ 6,730.00
19	\$ 150.00	\$ -	\$ 1,109.00	\$ 1,109.00	\$ 7,839.00
20	\$ 150.00	\$ -	\$ 1,151.00	\$ 1,151.00	\$ 8,990.00
21	\$ 150.00	\$ -	\$ 1,195.00	\$ 1,195.00	\$ 10,185.00
22	\$ 150.00	\$ -	\$ 1,240.00	\$ 1,240.00	\$ 11,425.00
23	\$ 150.00	\$ -	\$ 1,287.00	\$ 1,287.00	\$ 12,712.00
24	\$ 150.00	\$ -	\$ 1,336.00	\$ 1,336.00	\$ 14,048.00
25	\$ 150.00	\$ -	\$ 1,386.00	\$ 1,386.00	\$ 15,434.00

NOTE: Figures as provided by www.solar-estimate.org

# 11.1 SITE PLAN

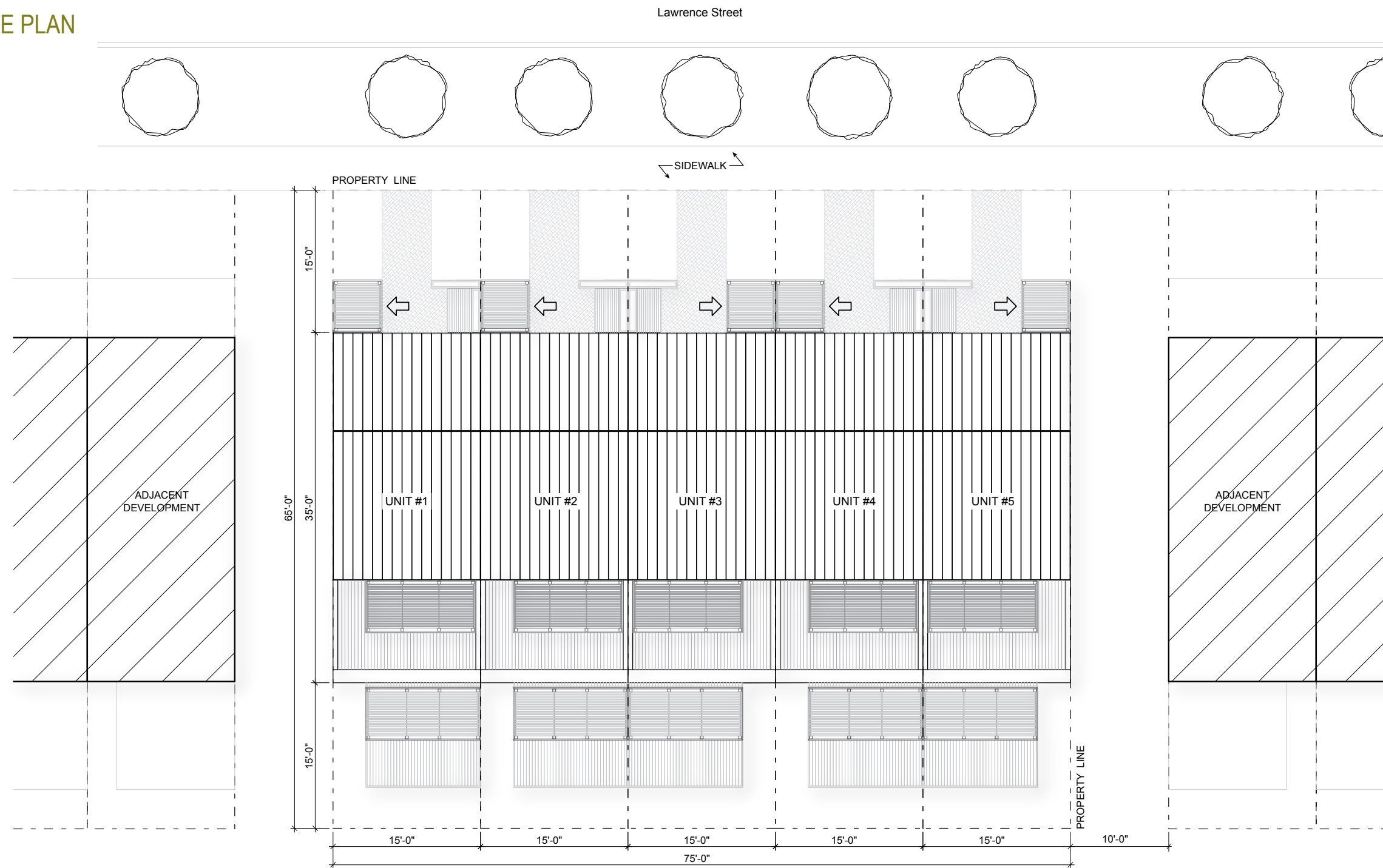

Site Plan  
Scale: 3/32" = 1'-0"





# 11.2 FLOOR PLANS

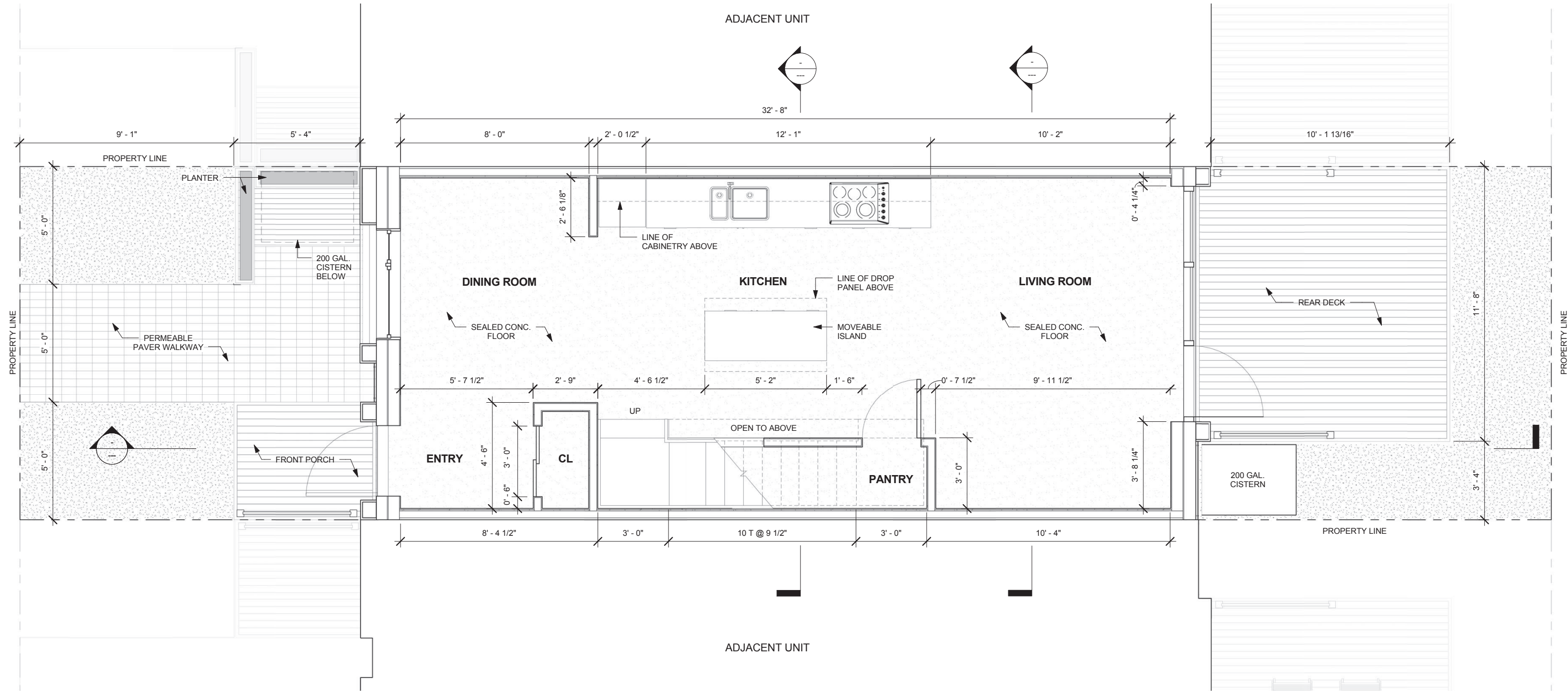

Floor Plan - Level Two  
Scale: 1/4" = 1'-0"

# 11.2 FLOOR PLANS

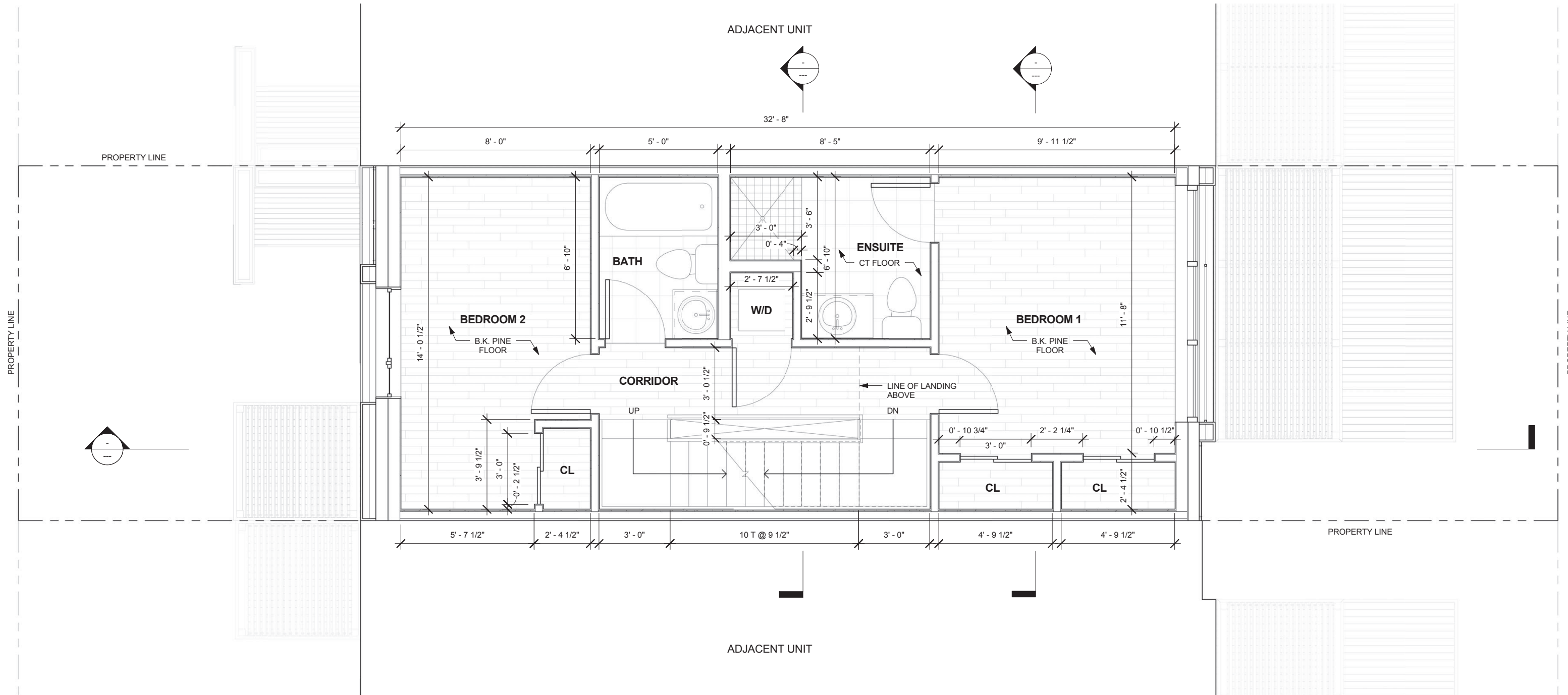

Floor Plan - Level One  
 Scale: 1/4" = 1'-0"

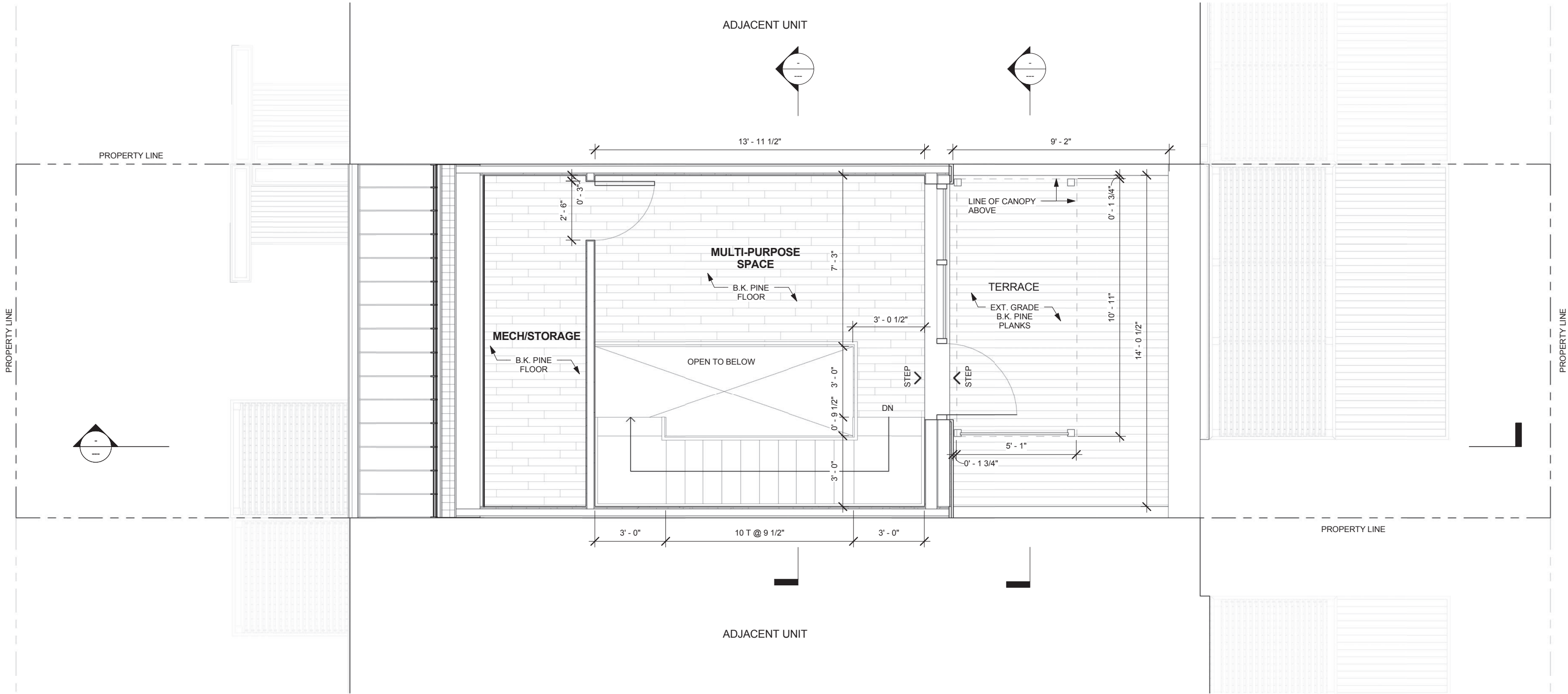

Floor Plan - Level Two  
 Scale: 1/4" = 1'-0"



# 11.3 BUILDING ELEVATIONS

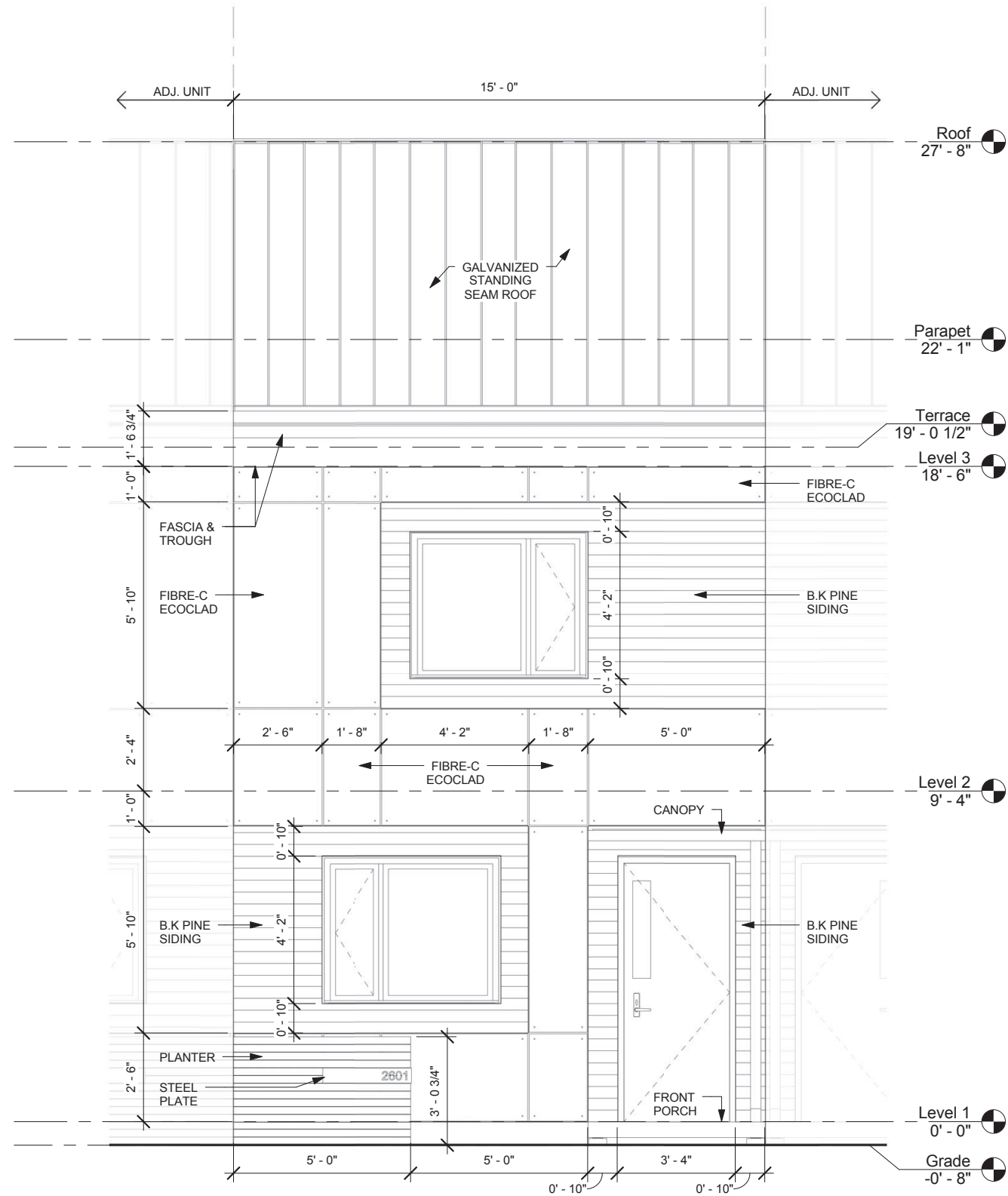

Building Elevation - North  
Scale: 1/4" = 1'-0"

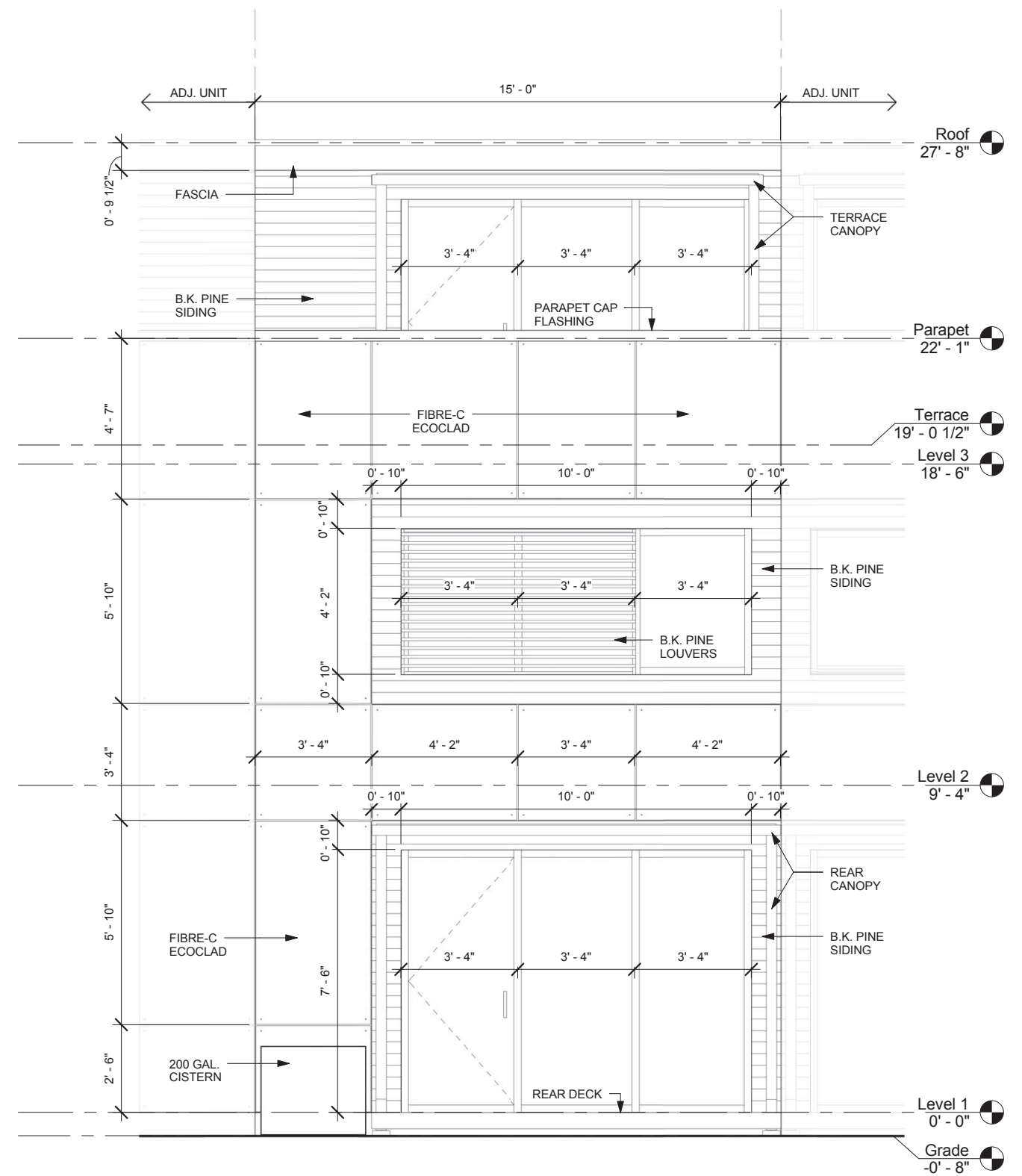

Building Elevation - South  
Scale: 1/4" = 1'-0"

# 11.4 BUILDING SECTIONS

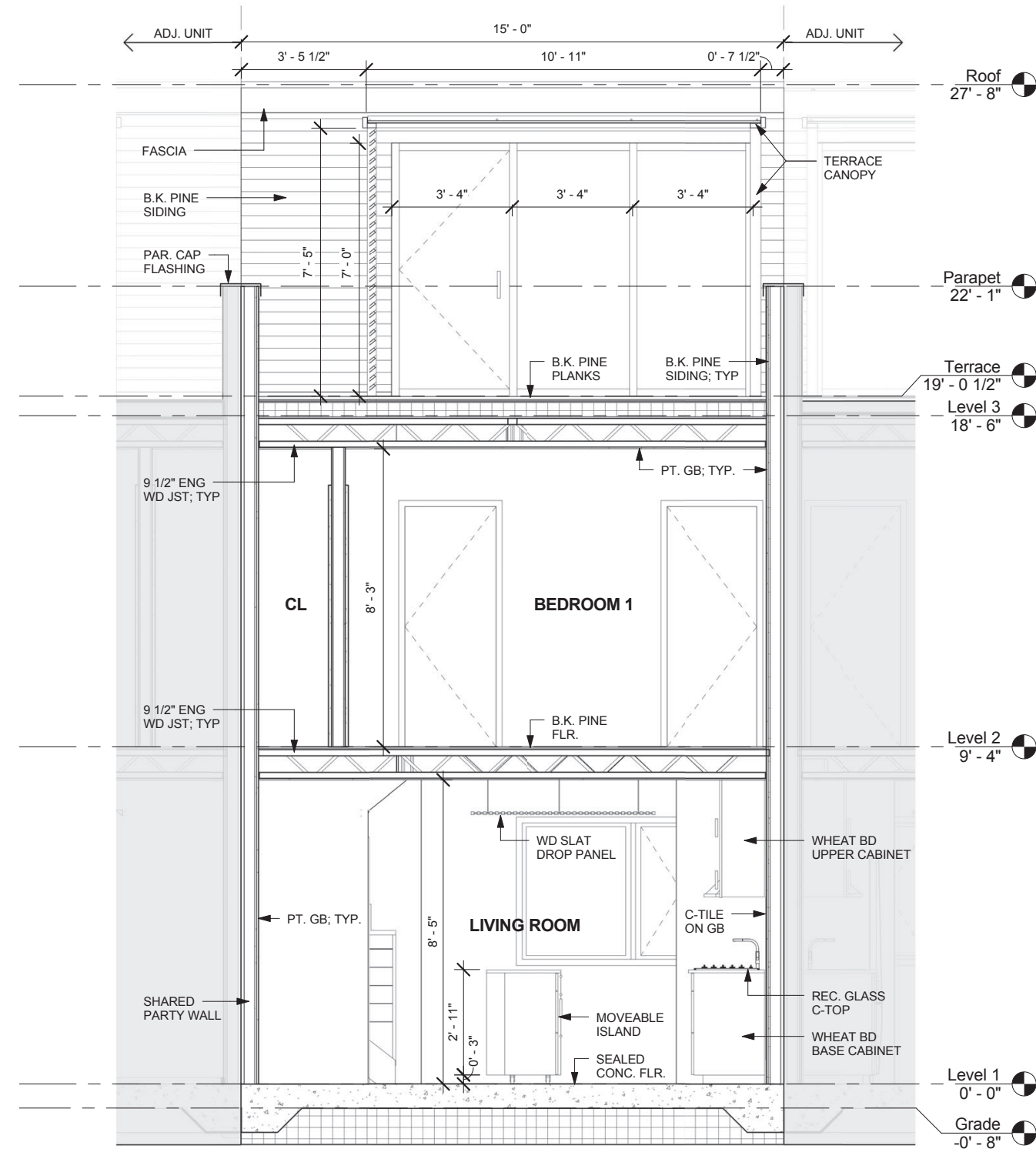

Building Section - A  
Scale: 1/4" = 1'-0"

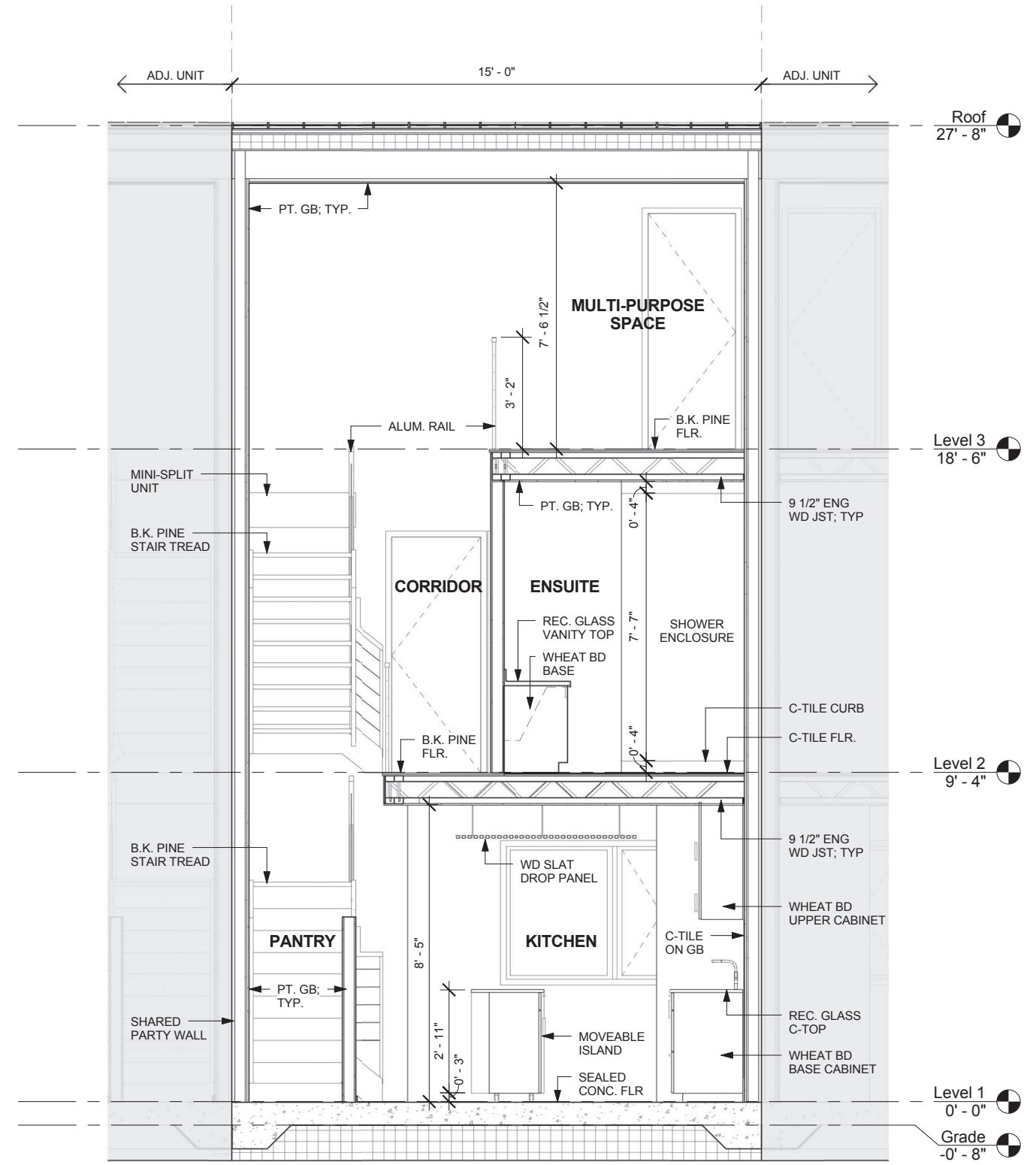

Building Section - B  
Scale: 1/4" = 1'-0"

# 11.4 BUILDING SECTIONS

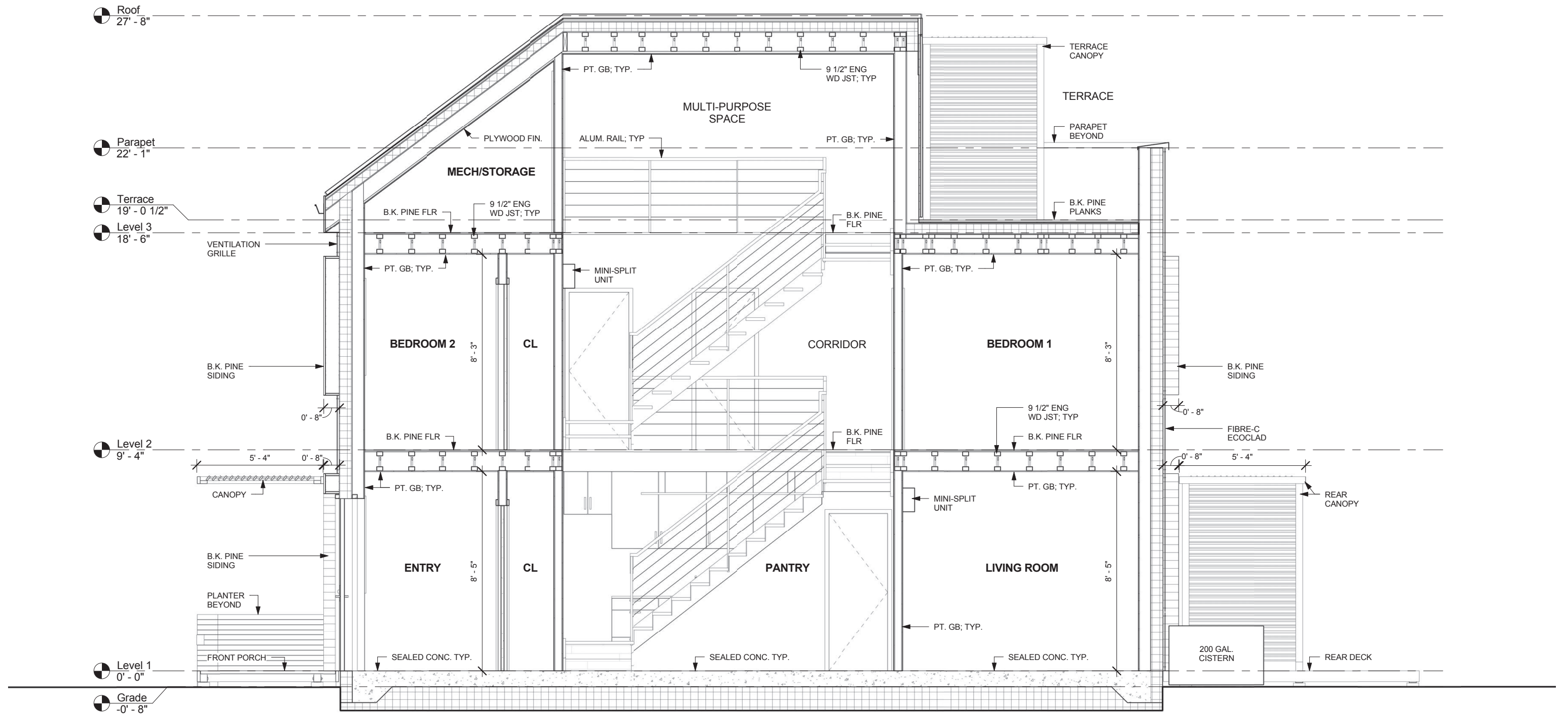

Building Section - C  
Scale: 1/4" = 1'-0"

# 11.5 CRITICAL DETAILS

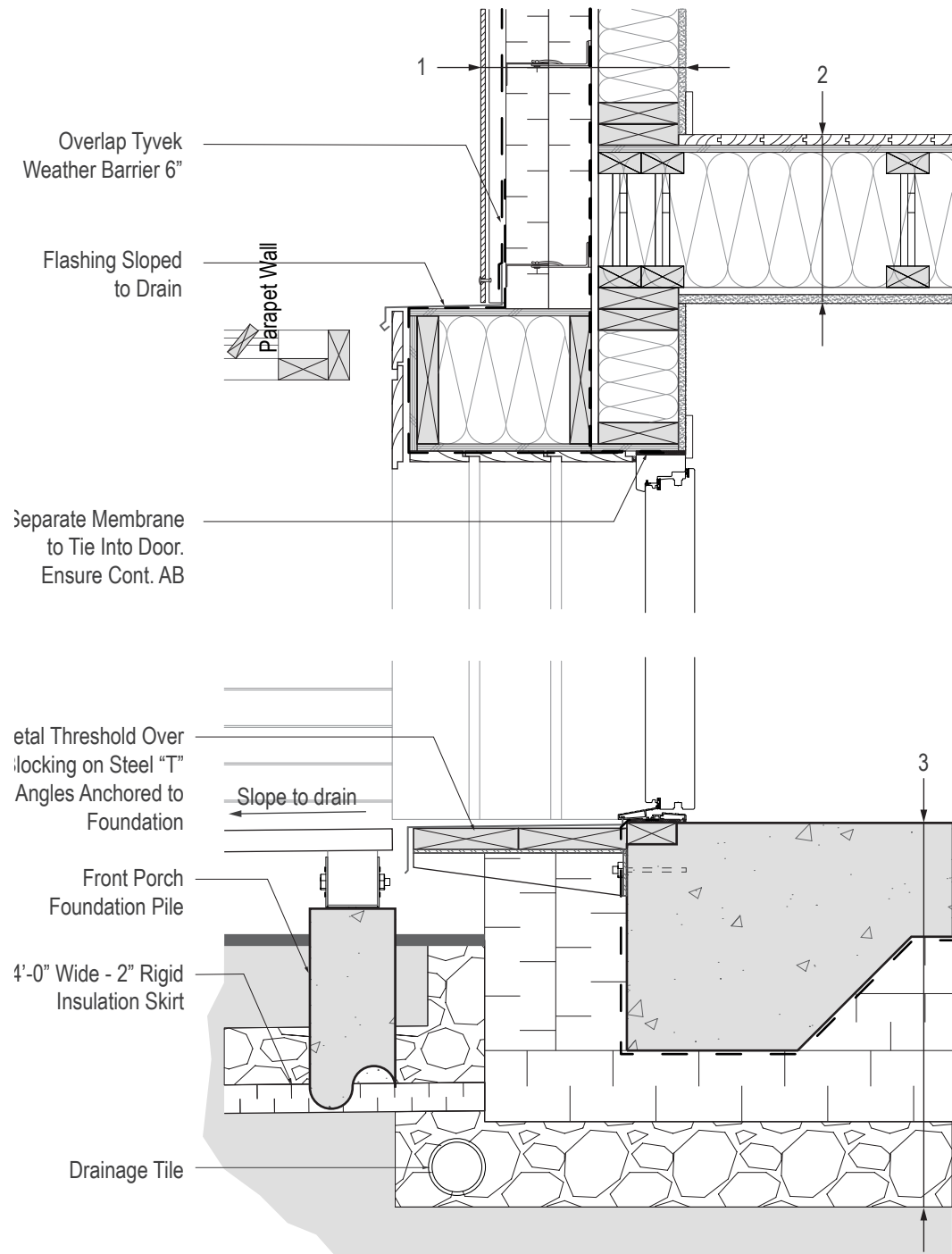

Detail 1 - Entry Door Sill & Top Plate  
Scale: 1" = 1'-0"

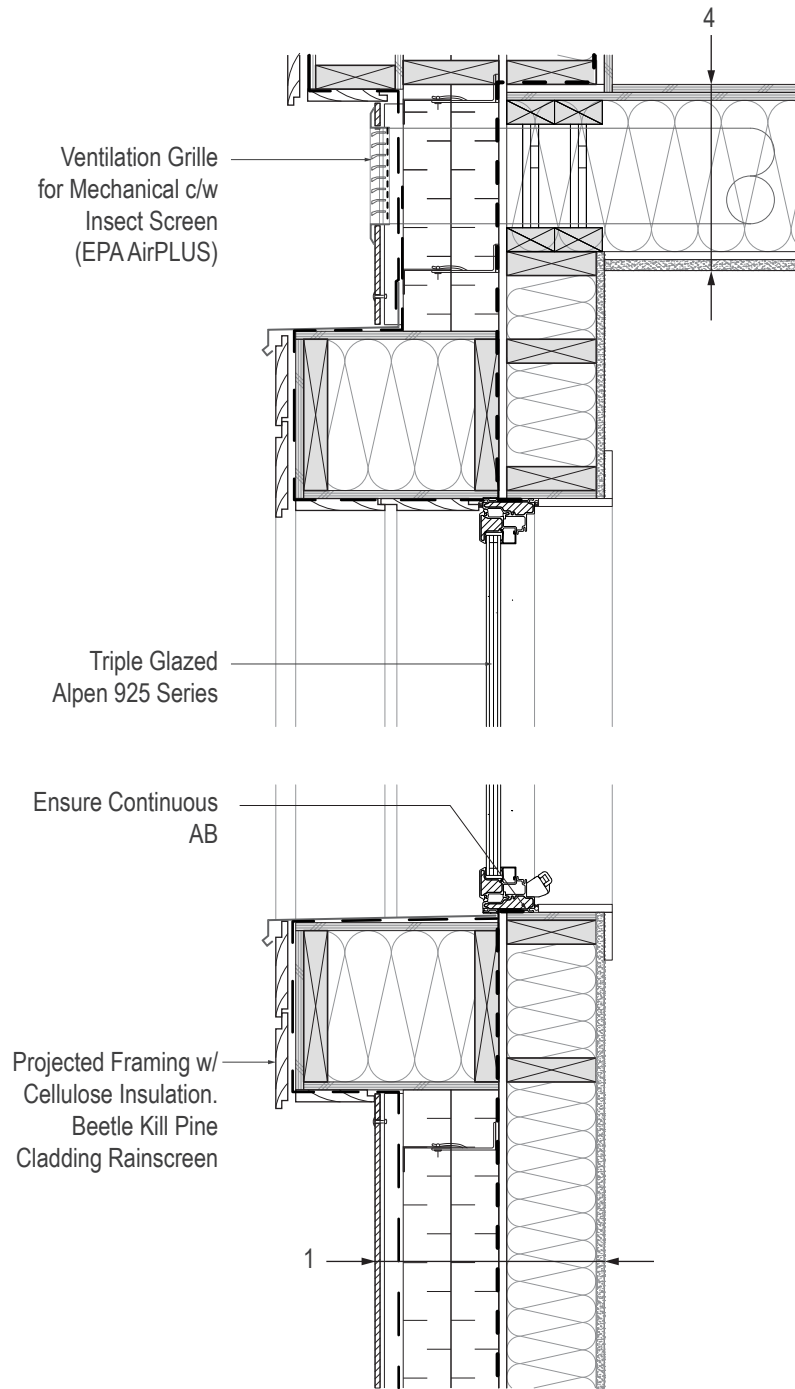

Detail 2 - North Aperture Sill & Top Plate  
Scale: 1" = 1'-0"

- 1 Exterior Wall Assembly (Exterior to Interior)  
 Fibre-C Ecoclad on  
 Continuous Vertical Rail for Anchoring  
 1" Ventilation Cavity  
 Tyvek Weather Barrier Ship-lapped for Drainage  
 2 Layers - 3" Roxul EPS Insulation (R-25.8)  
 1/2" Zip System Air/Vapor Barrier  
 2 x 6" Structural Stud Wall at 16" O/C  
 5-1/2" Cellulose Insulation (R-21)  
 5/8" Gypsum Wall Board Finished w/  
 Zero VOC Paint (EPA AirPLUS)
- 2 Upper Floor Floor Assembly (Floor to Ceiling)  
 1/2" Beetle Kill Floor w/ Waterbase Finish (EPA AirPLUS)  
 1/2" Plywood Subfloor  
 9-1/2" Engineered Wood Joist w/ Acoustic Insulation Roxul  
 AFB Resilient Channels  
 5/8" Gypsum Wall Board Finished w/  
 Zero VOC Paint (EPA AirPLUS)
- 3 Ground Floor Assembly (Interior to Exterior)  
 8" Sealed Concrete Slab on Grade  
 EPS Rigid Foam Raft (R-47.6)  
 10 mil Poly Air Barrier  
 6" Compacted Gravel (EPA AirPLUS)
- 4 Mechanical/Storage Floor Assembly (Floor to Ceiling)  
 1/2" Plywood Floor  
 1/2" Plywood Subfloor  
 9-1/2" Engineered Wood Joist w/ Acoustic Insulation Roxul  
 AFB Resilient Channels  
 5/8" Gypsum Wall Board Finished w/  
 Zero VOC Paint (EPA AirPLUS)

# 11.5 CRITICAL DETAILS

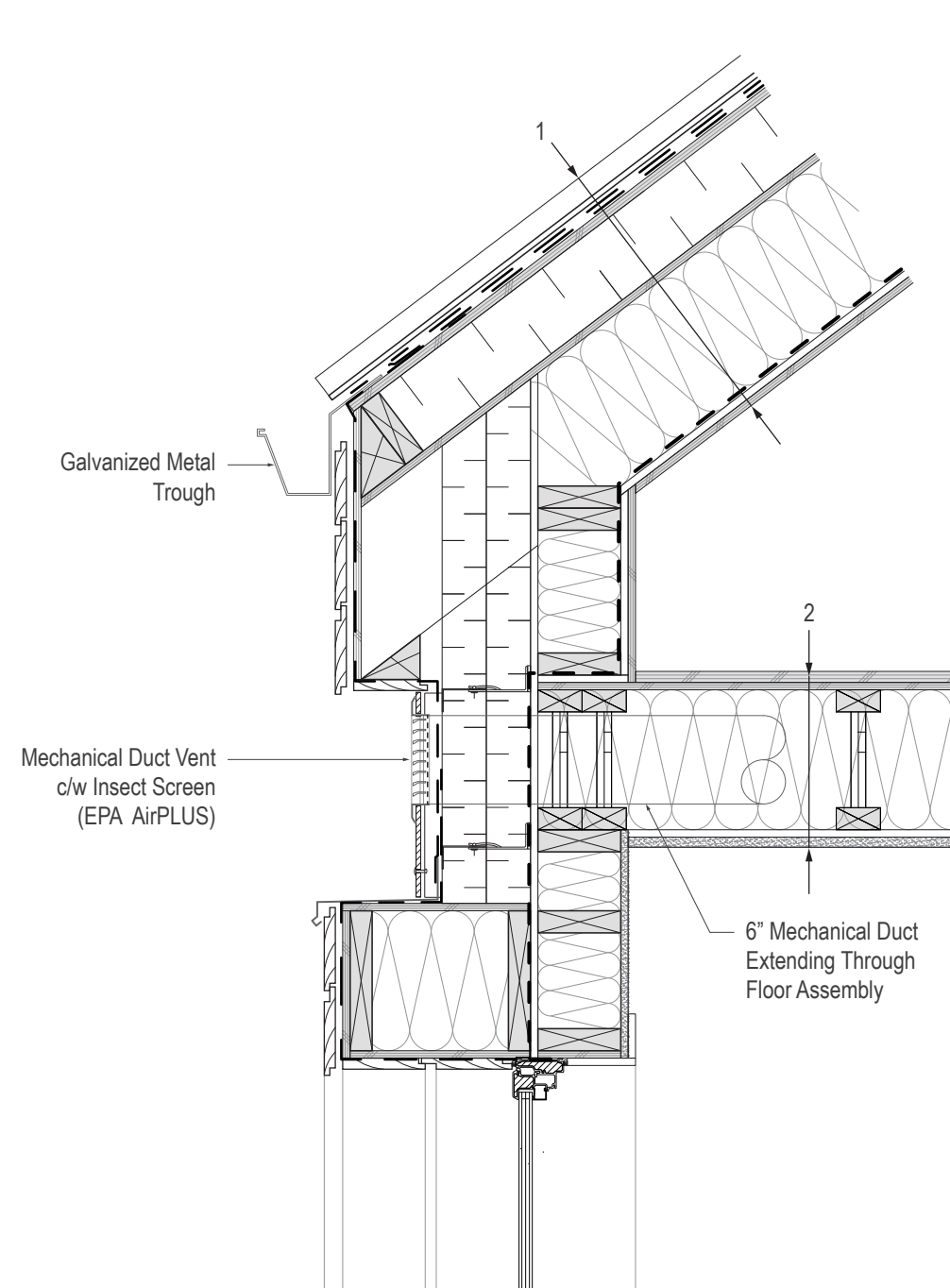

Detail 3 - North Wall Junction to Roof  
Scale: 1" = 1'-0"

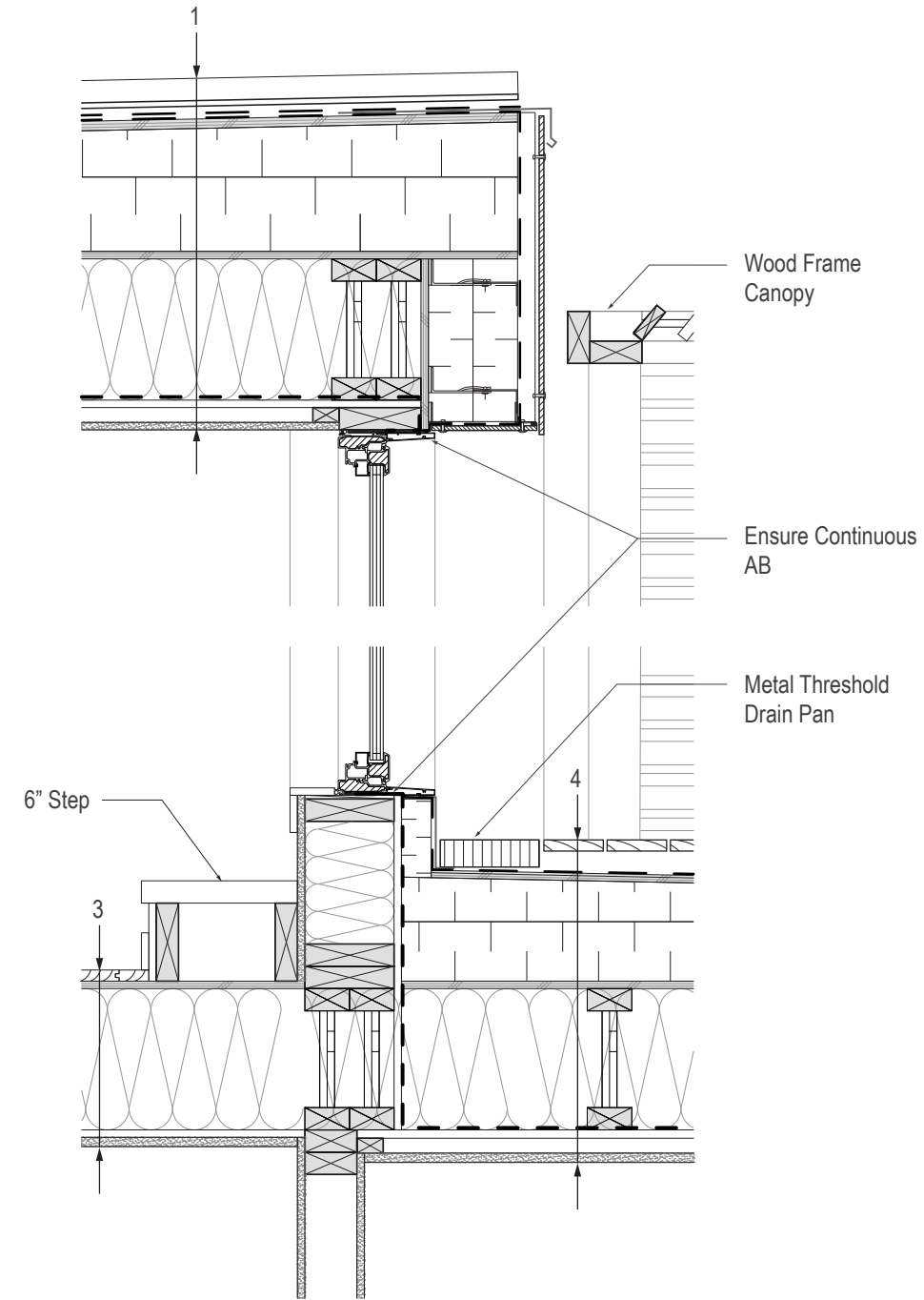

Detail 4 - Terrace Door Sill & Top Plate  
Scale: 1" = 1'-0"

- 1 | Roof Assembly (Exterior to Interior)  
Galvanized Standing Seam Metal Roof  
2 Layers - 15 lb. Felt  
5/8" Plywood Sheathing  
EPS Rigid Insulation (R-20)  
1/2" Plywood Sheathing  
2 x 10" Wood Rafters at 16" OC  
9-1/2" Blown Cellulose Insulation (R-33.25)  
1/2" Zip System Air/Vapor Barrier  
1" Wood Furring  
5/8" Gypsum Wall Board Finished w/  
Zero VOC Paint (EPA AirPLUS)
- 2 | Mechanical/Storage Floor Assembly (Floor to Ceiling)  
1/2" Plywood Floor  
1/2" Plywood Underlay  
9-1/2" Engineered Wood Joist w/ Acoustic Insulation Roxul  
AFB Resilient Channels  
5/8" Gypsum Wall Board Finished w/  
Zero VOC paint (EPA AirPLUS)
- 3 | Upper Floor Assembly (Floor to Ceiling)  
1/2" Beetle Kill Floor w/ Waterbase Finish (EPA AirPLUS)  
1/2" Plywood Subfloor  
9-1/2" Engineered Wood Joist w/ Acoustic Insulation Roxul  
AFB Resilient Channels  
5/8" Gypsum Wall Board Finished w/  
Zero VOC Paint (EPA AirPLUS)
- 4 | Roof Deck Assembly (Exterior to Interior)  
Beetle Kill Pine Deck Planks on Pads  
2-ply SBS Roofing Membrane  
1/2" Plywood Sheathing  
7" EPS Rigid Insulation Sloped to Drain (Min. 2%)  
1/2" Plywood Sheathing  
9-1/2" Engineered Wood Joist w/ Acoustic Insulation Roxul  
9-1/2" Blown Cellulose Insulation (R-33.25)  
1/2" Zip System Air/Vapor Barrier  
1" Wood Furring  
5/8" Gypsum Wall Board Finished w/  
Zero VOC Paint (EPA AirPLUS)



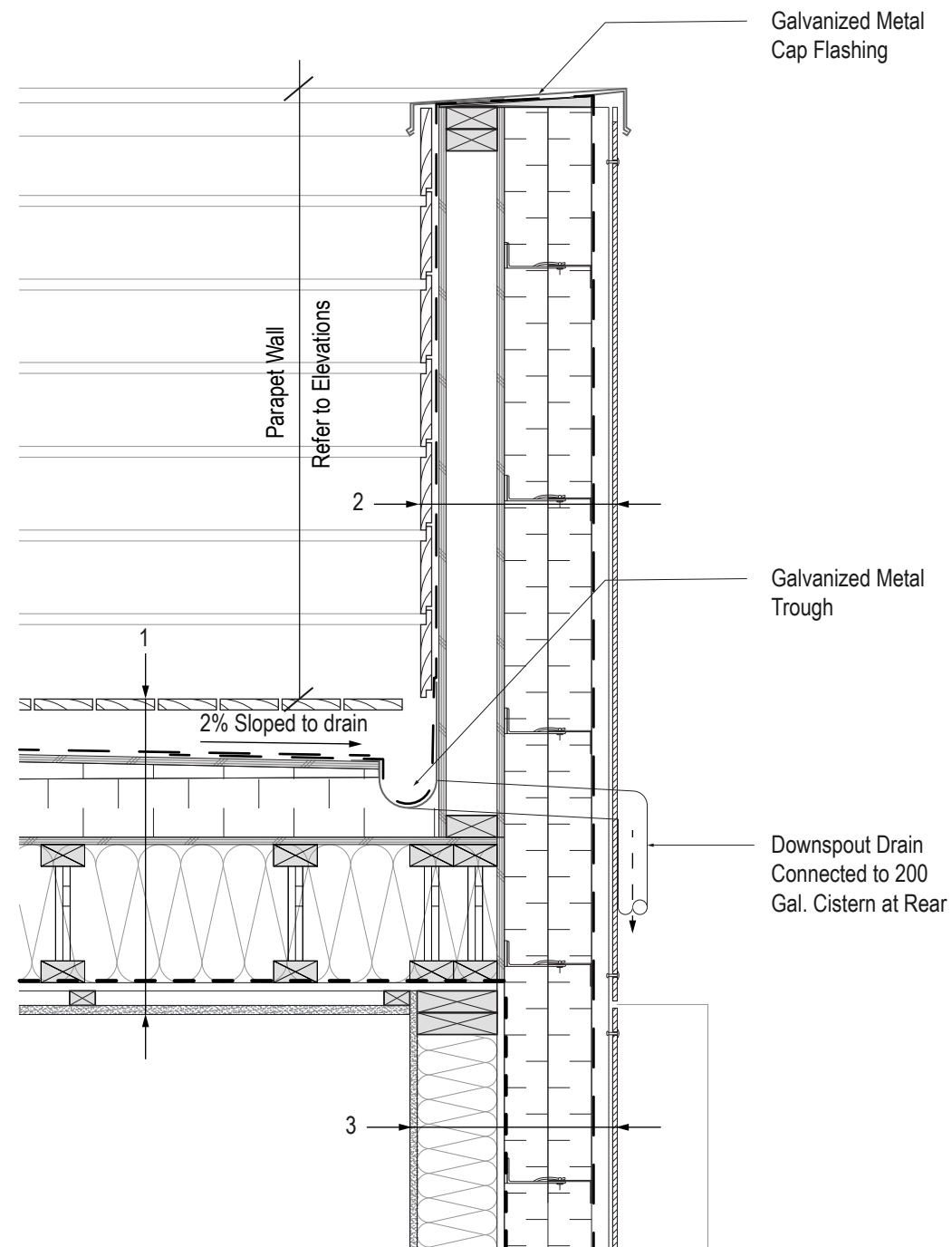

Detail 5 - South Parapet Assembly  
Scale: 1" = 1'-0"

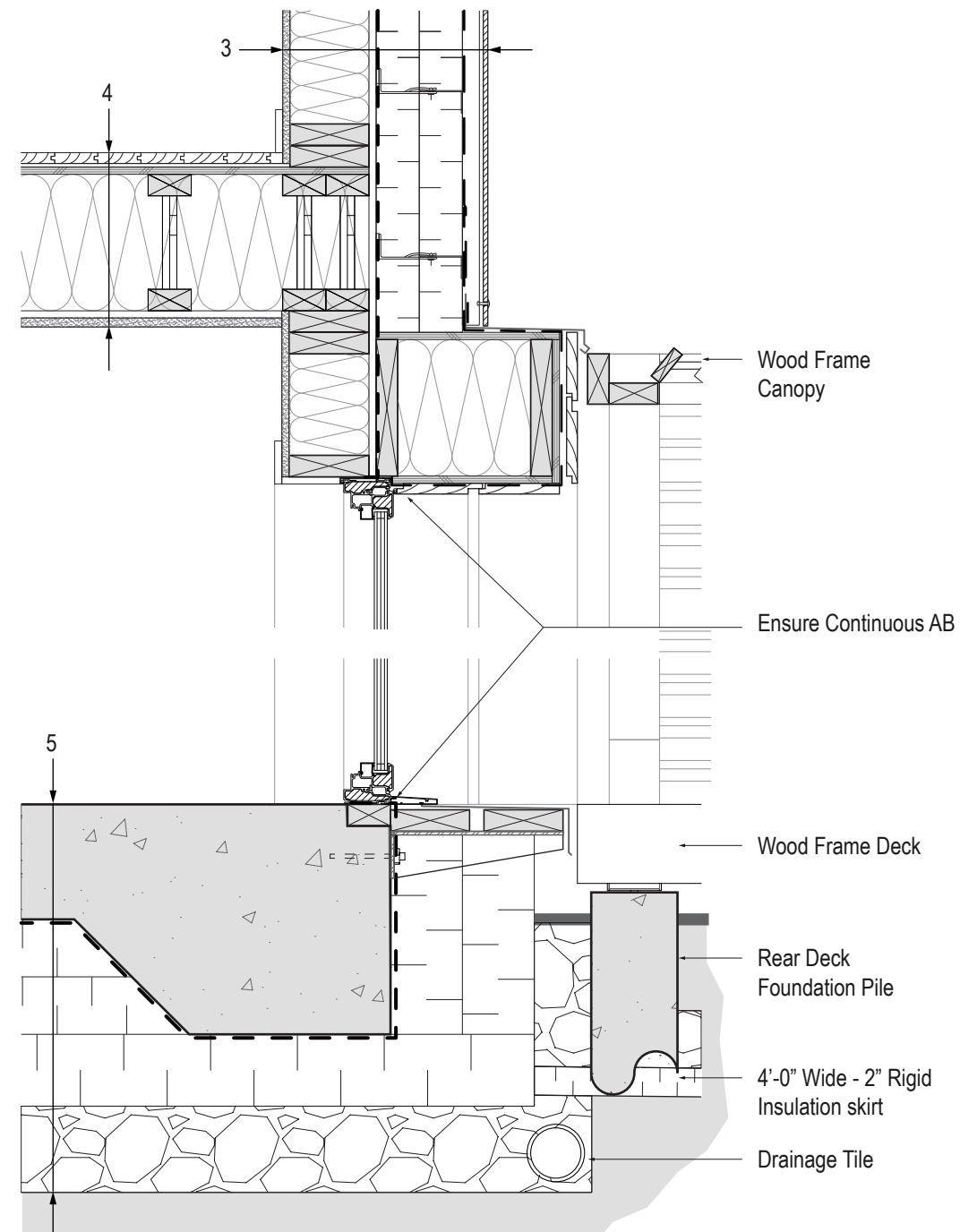

Detail 6 - Rear Deck Door Sill & Top Plate  
Scale: 1" = 1'-0"

- 1 **Roof Deck Assembly (Top to Ceiling)**  
 Beetle Kill Pine Deck Planks on Pads  
 2-ply SBS Roofing Membrane  
 1/2" Plywood Sheathing  
 7" EPS Rigid Insulation Sloped to Drain (Min. 2%)  
 1/2" Plywood Sheathing  
 9-1/2" Engineered Wood Joist w/ Acoustic Insulation Roxul  
 9-1/2" Blown Cellulose Insulation (R-33.25)  
 1/2" Zip System Air/Vapor Barrier  
 1" Wood Furring  
 5/8" Gypsum Wall Board Finished w/  
 Zero VOC Paint (EPA AirPLUS)
- 2 **Parapet Wall Assembly (Out to In)**  
 Fibre-C Ecoclad on  
 Continuous Vertical Rail for Anchoring  
 1" Ventilation Cavity  
 Tyvek Weather Barrier Ship-lapped for Drainage  
 2 Layers - 3" Roxul EPS Insulation (R-25.8)  
 1/2" Plywood Sheathing  
 2 x 4" Structural Stud Wall at 16" O/C  
 1/2" Plywood Sheathing  
 Tyvek Weather Barrier  
 1/2" Beetle Kill Pine Cladding
- 3 **Exterior Wall Assembly (Exterior to Interior)**  
 Fibre-C Ecoclad on  
 Continuous Vertical Rail for Anchoring  
 1" Ventilation Cavity  
 Tyvek Weather Barrier Ship-lapped for Drainage  
 2 Layers - 3" Roxul EPS Insulation (R-25.8)  
 1/2" Zip System Air/Vapor Barrier  
 2 x 6" Structural Stud Wall at 16" O/C  
 5-1/2" Cellulose Insulation (R-21)  
 5/8" Gypsum Wall Board Finished w/  
 Zero VOC Paint (EPA AirPLUS)
- 4 **Upper Floor Assembly (Floor to Ceiling)**  
 1/2" Beetle Kill Floor w/ Waterbase Finish (EPA AirPLUS)  
 1/2" Plywood Subfloor  
 9-1/2" Engineered Wood Joist w/ Acoustic Insulation Roxul  
 AFB Resilient Channels  
 5/8" Gypsum Wall Board Finished w/  
 Zero VOC Paint (EPA AirPLUS)
- 5 **Ground Floor Assembly (Finish to Below Slab)**  
 8" Sealed Concrete Slab on Grade  
 EPS Rigid Foam Raft (R-47.6)  
 10 mil Poly Air Barrier  
 6" Compacted Gravel (EPA AirPLUS)

## 11.6 STRUCTURAL DETAILS

The structural design of the Harvest Home is simplistic as the unit is quite narrow and only two and one half storeys. Traditional platform framing techniques are incorporated into the design for their simplicity and widespread use among North American construction trades. A raft slab foundation is selected for its ability to provide exceptional thermal and continuous air barriers. Exterior walls are framed with 2" x 6" wood studs to ensure additional insulation can be provided. Engineered Wood Joists are used to frame the floor and roof. The decision to select open web joists is made due to their ability to easily run building service lines through the depth of the floor/ceiling assemblies. Open web wood joists are also capable of spanning further with lesser depths, thus maximizing floor to ceiling heights. The only portion of the home that is not framed with open web wood joists is above the Mechanical/Storage Room, where 2" x 10" wood joists are used. All timber used in the Harvest Home is to be locally sourced and FSC certified.

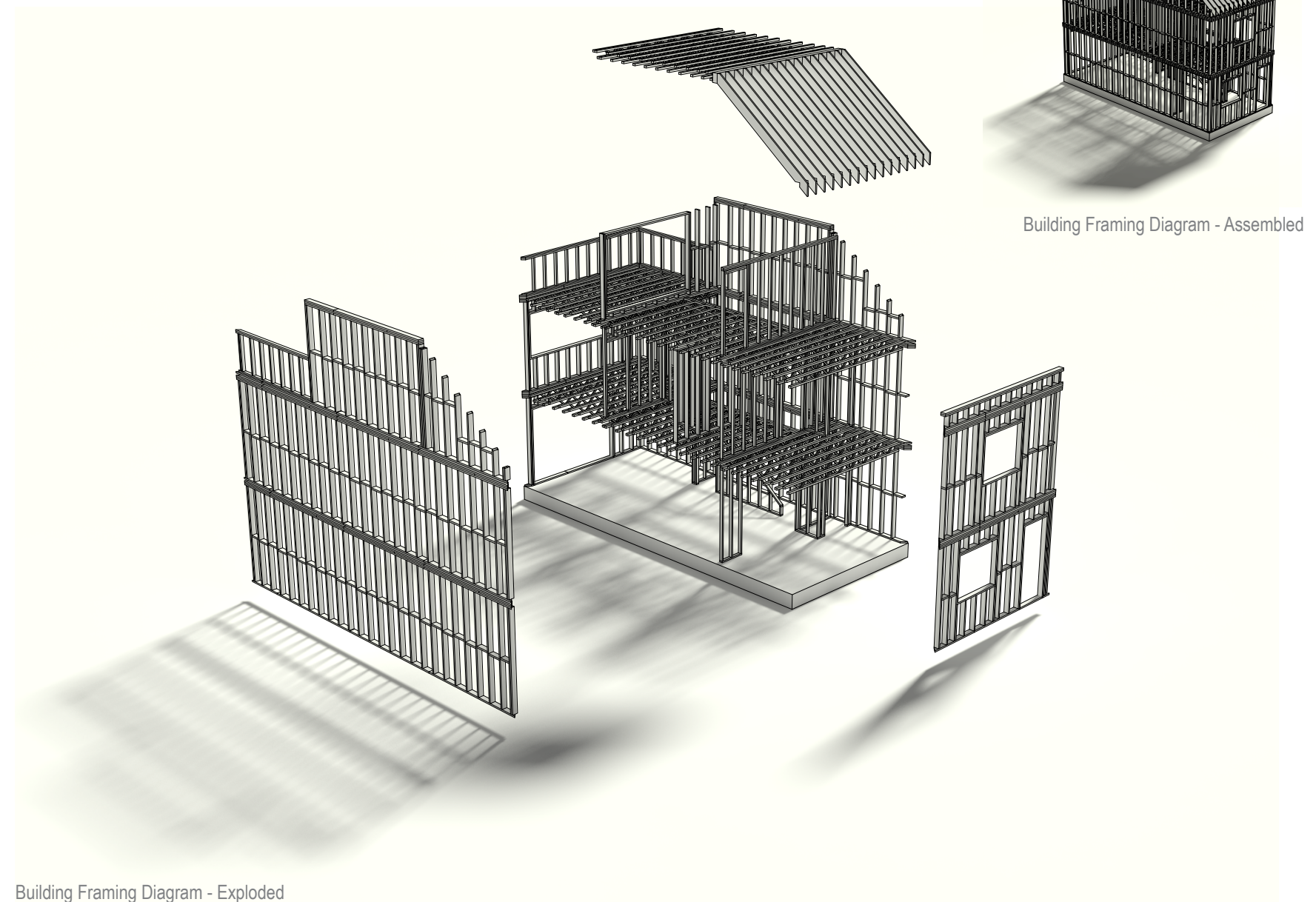

## 11.7 WINDOW & ROOM SCHEDULE

ROOM FINISH SCHEDULE						
ROOM NAME	LOCATION	LEVEL	BASE	WALLS	CEILING	REMARKS
ENTRY	LEVEL ONE	S-CONC	PT-BB	PT-GB	PT-GB	
DINING ROOM	LEVEL ONE	S-CONC	PT-BB	PT-GB	PT-GB	
KITCHEN	LEVEL ONE	S-CONC	PT-BB	PT-GB	PT-GB	C-TILE BACKSPASH AS INDICATED
LIVING ROOM	LEVEL ONE	S-CONC	PT-BB	PT-GB	PT-GB	
PANTRY	LEVEL ONE	S-CONC	PT-BB	PT-GB	PT-GB	
BEDROOM 1	LEVEL TWO	BKP	PT-BB	PT-GB	PT-GB	
ENSUITE	LEVEL TWO	C-TILE	PT-BB	PT-GB*	PT-GB*	FULL HEIGHT C-TILE AT SHOWER ENCLOSURE
CORRIDOR	LEVEL TWO	BKP	PT-BB	PT-GB	PT-GB	
LAUNDRY	LEVEL TWO	C-TILE	PT-BB	PT-GB	PT-GB	
BEDROOM 2	LEVEL TWO	BKP	PT-BB	PT-GB	PT-GB	
BATH	LEVEL TWO	C-TILE	PT-BB	PT-GB*	PT-GB*	FULL HEIGHT C-TILE AT TUB ENCLOSURE
MULTI-PURPOSE SPACE	LEVEL THREE	BKP	PT-BB	PT-GB	PT-GB	
MECHANICAL/STORAGE	LEVEL THREE	BKP	N/A	UNF-PLY	UNF-PLY	

\* WALLS/CEILINGS AT BATH/ENSUITE TO BE OF WATER RESISTANT GB

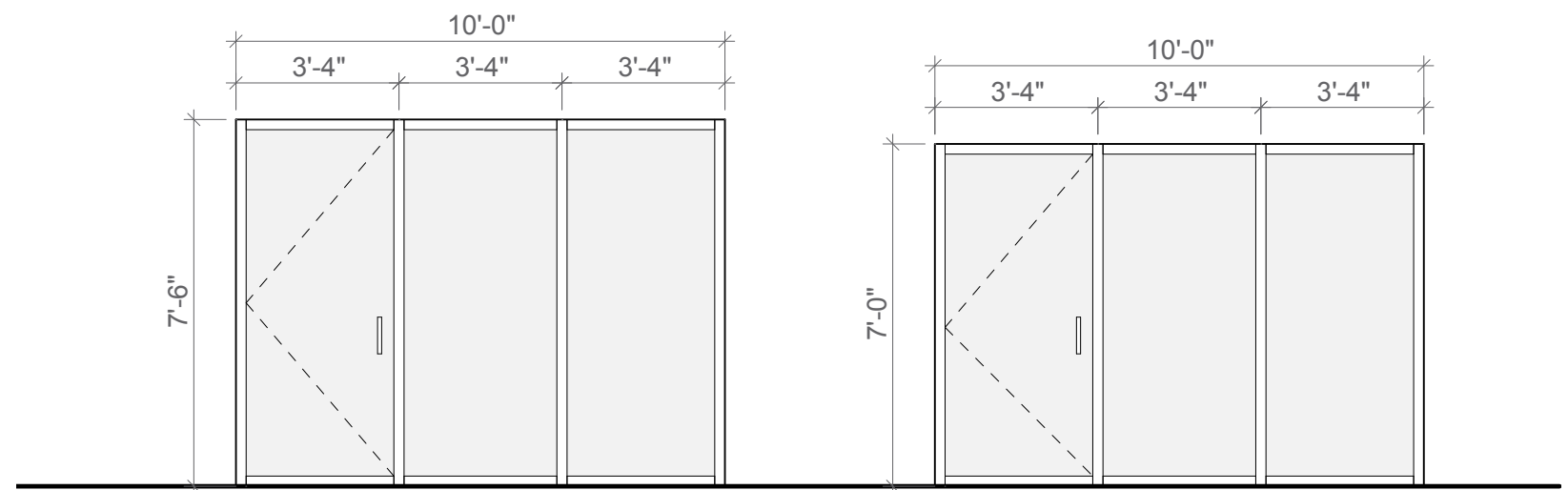

WINDOW SCHEDULE				
TYPE	LOCATION	SIZE(WXH)	DESCRIPTION	REMARKS
A	DINING ROOM GROUND	5'-0"X4'-0"	ALPEN 925 SERIES TRIPLE GLAZED FIBREGLASS BLACK PAINTED FRAME ONE FIXED ONE CASEMENT PANEL	
A	BEDROOM 2 SECOND FLOOR	5'-0"X4'-0"	ALPEN 925 SERIES TRIPLE GLAZED FIBREGLASS BLACK PAINTED FRAME ONE FIXED ONE CASEMENT PANEL	
B	BEDROOM 1 SECOND FLOOR	9'-6"X4'-0"	ALPEN 925 SERIES TRIPLE GLAZED FIBREGLASS BLACK PAINTED FRAME ONE CASEMENT TWO FIXED PANELS	CUSTOM LOUVRES TO BE BUILT OVER WINDOW FRAME FOR SHADING
C	LIVING ROOM GROUND FLOOR	10'-0"X7'-6"	ALPEN 925 SERIES TRIPLE GLAZED FIBREGLASS BLACK PAINTED FRAME ONE DOOR TWO FIXED PANELS	SEPARATE ALPEN DOOR HARDWARE REQ'D
D	MULTI-PURPOSE THIRD FLOOR	10'-0"X6'-6"	ALPEN 925 SERIES TRIPLE GLAZED FIBREGLASS BLACK PAINTED FRAME ONE DOOR TWO FIXED PANELS	SEPARATE ALPEN DOOR HARDWARE REQ'D

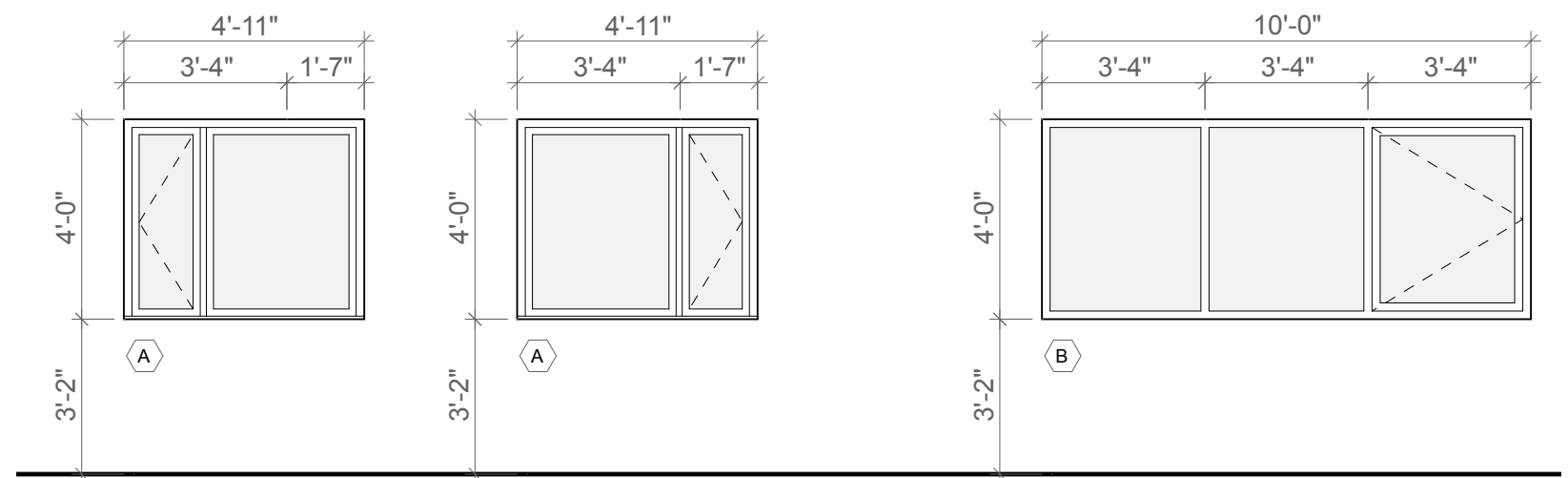

# 11.8 MECHANICAL PLANS

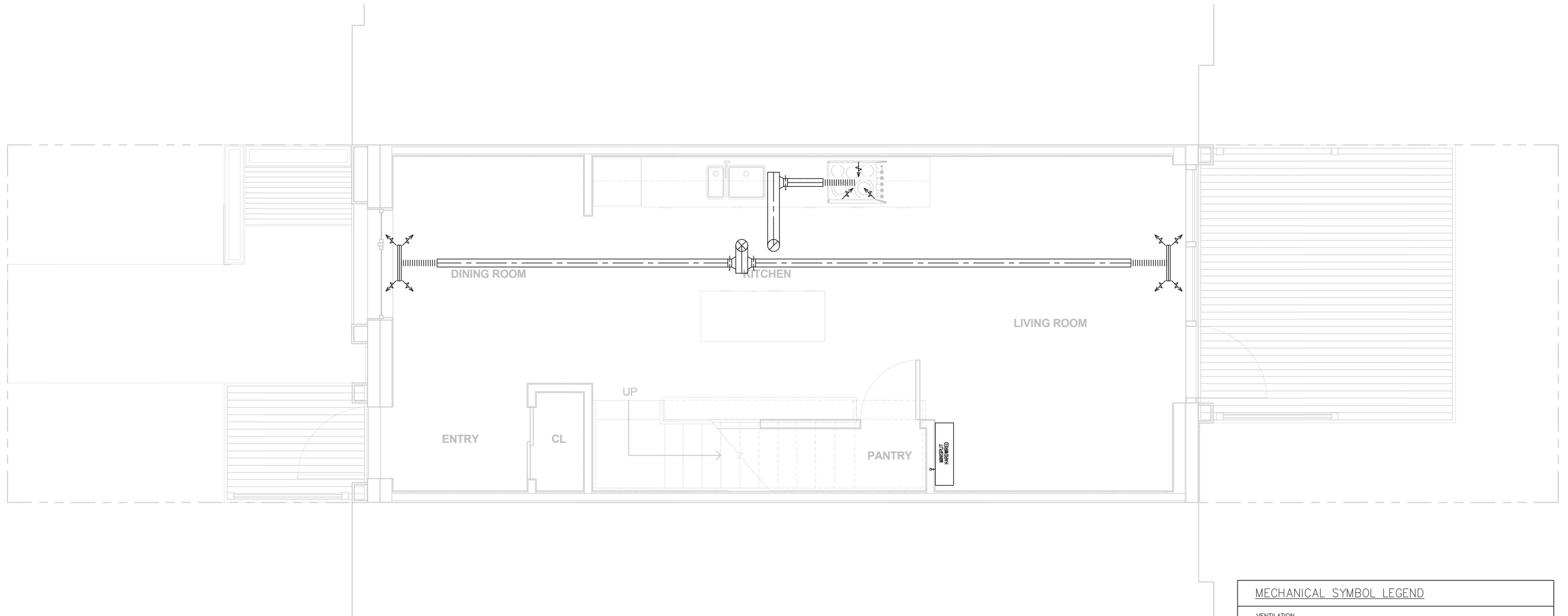

Mechanical Plan - Level One  
Scale: 1/4" = 1'-0"



MECHANICAL SYMBOL LEGEND			
VENTILATION			
	ROUND OR OVAL DUCTWORK		LINEAR DIFFUSER
	LONG RADIUS ELBOW		FAN CONNECTION AS SPECIFIED
	SUPPLY DUCTWORK UP		FLEXIBLE DUCTWORK
	SUPPLY DUCTWORK DOWN		BALANCE DAMPER
	RETURN OR EXHAUST DUCTWORK UP		SPIN-ON TAKEOFF WITH BALANCE DAMPER
	RETURN OR EXHAUST DUCTWORK DOWN		AIR FLOW ARROW

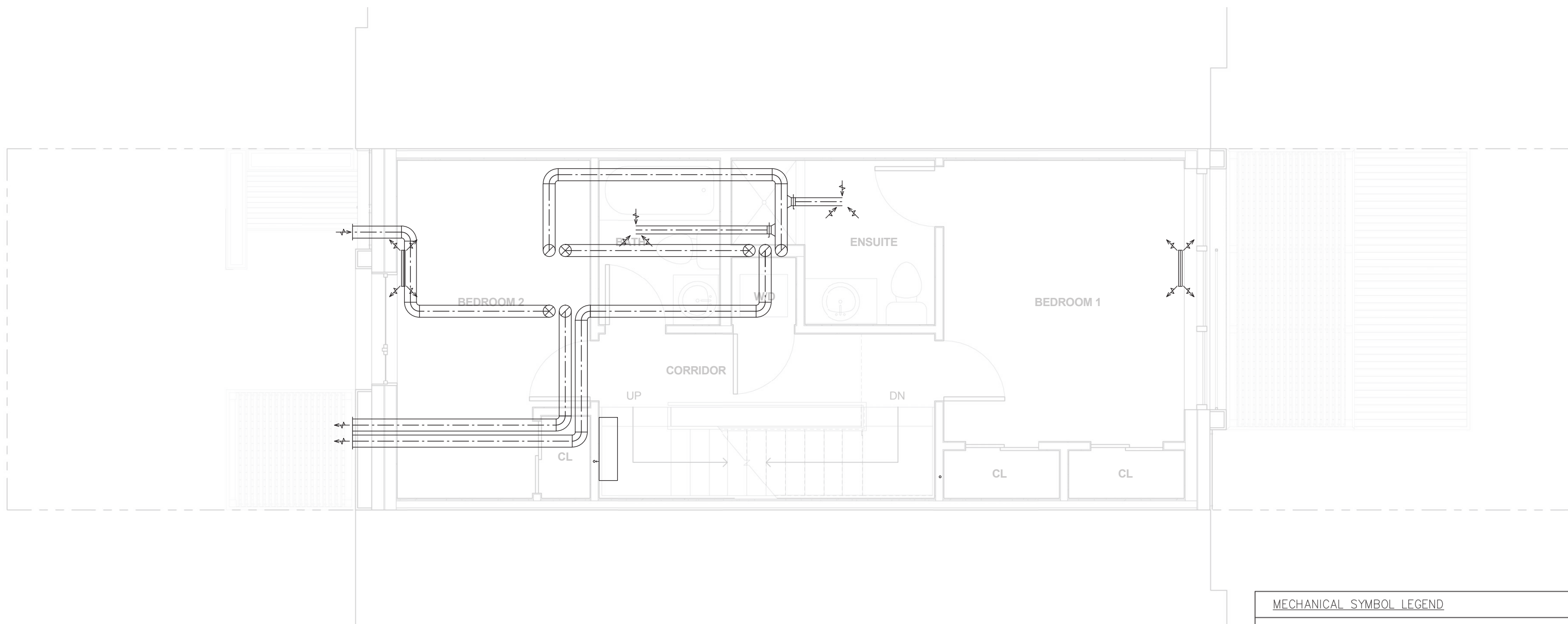

Mechanical Plan - Level Two  
Scale: 1/4" = 1'-0"



MECHANICAL SYMBOL LEGEND	
<b>VENTILATION</b>	
	ROUND OR OVAL DUCTWORK
	LONG RADIUS ELBOW
	SUPPLY DUCTWORK UP
	SUPPLY DUCTWORK DOWN
	RETURN OR EXHAUST DUCTWORK UP
	RETURN OR EXHAUST DUCTWORK DOWN
	LINEAR DIFFUSER
	FAN CONNECTION AS SPECIFIED
	FLEXIBLE DUCTWORK
	BALANCE DAMPER
	SPIN-ON TAKEOFF WITH BALANCE DAMPER
	AIR FLOW ARROW

# 11.8 MECHANICAL PLANS

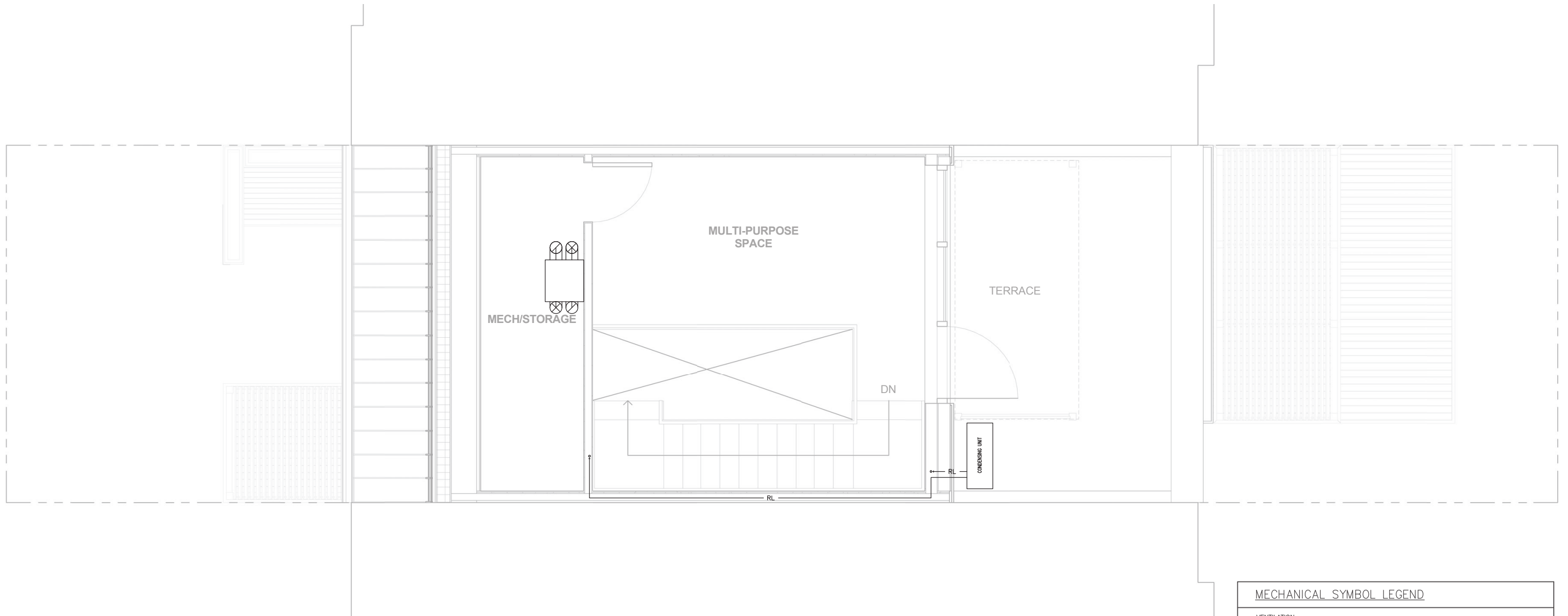

Mechanical Plan - Level Three  
Scale: 1/4" = 1'-0"



MECHANICAL SYMBOL LEGEND	
VENTILATION	
	ROUND OR OVAL DUCTWORK
	LONG RADIUS ELBOW
	SUPPLY DUCTWORK UP
	SUPPLY DUCTWORK DOWN
	RETURN OR EXHAUST DUCTWORK UP
	RETURN OR EXHAUST DUCTWORK DOWN
	LINEAR DIFFUSER
	FAN CONNECTION AS SPECIFIED
	FLEXIBLE DUCTWORK
	BALANCE DAMPER
	SPIN-ON TAKEOFF WITH BALANCE DAMPER
	AIR FLOW ARROW

# 11.9 PLUMBING PLANS

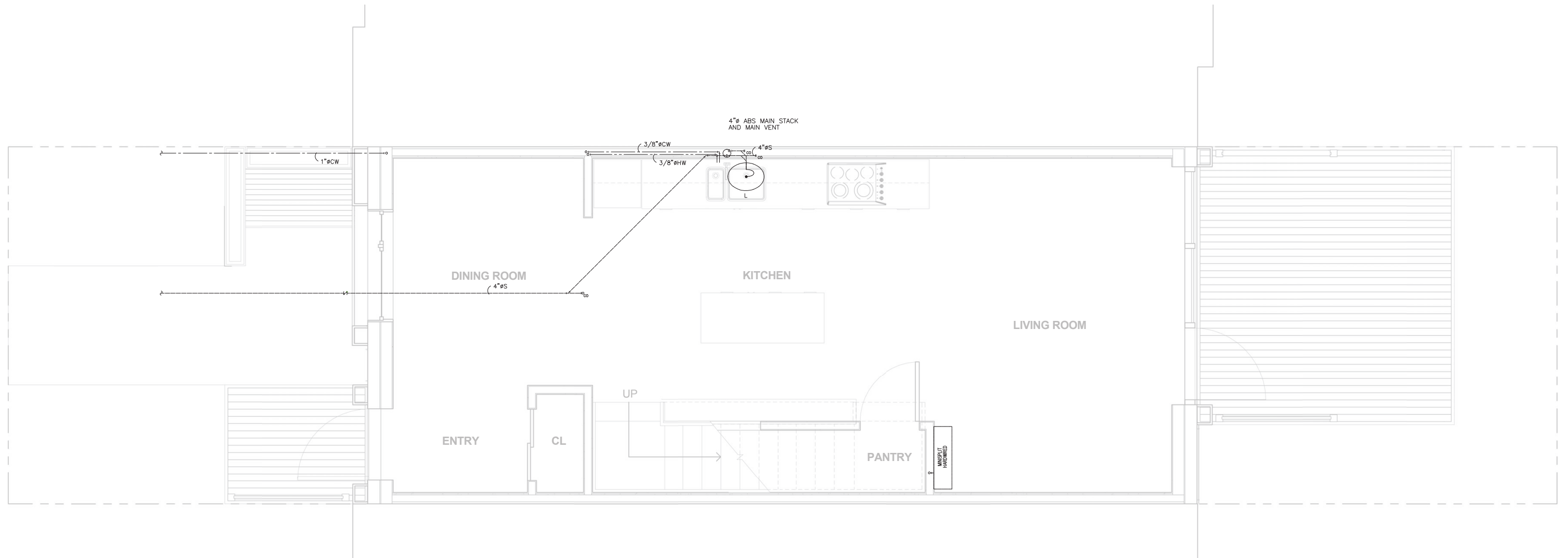

Plumbing Plan - Level One  
Scale: 1/4" = 1'-0"



PLUMBING SYMBOL LEGEND		
PLUMBING FIXTURES	PLUMBING & DRAINAGE	PIPE FITTINGS
WC	— DCW — DOMESTIC COLD WATER	PIPE ELBOW
L	— HW — HOT WATER	ELBOW, UP
BT	- - - - SANITARY (BELOW FLOOR OR BURIED)	ELBOW, DOWN
SH	— RL — LIQUID REFRIGERANT	PIPE TEE
	CO  CLEANOUT PLUG	TEE, UP
	CO  CLEANOUT FLOOR	TEE, DOWN
	U  TRAP	BALL VALVE
	FD  FLOOR DRAIN	CHECK VALVE
		BACKFLOW PREVENTER

# 11.9 PLUMBING PLANS

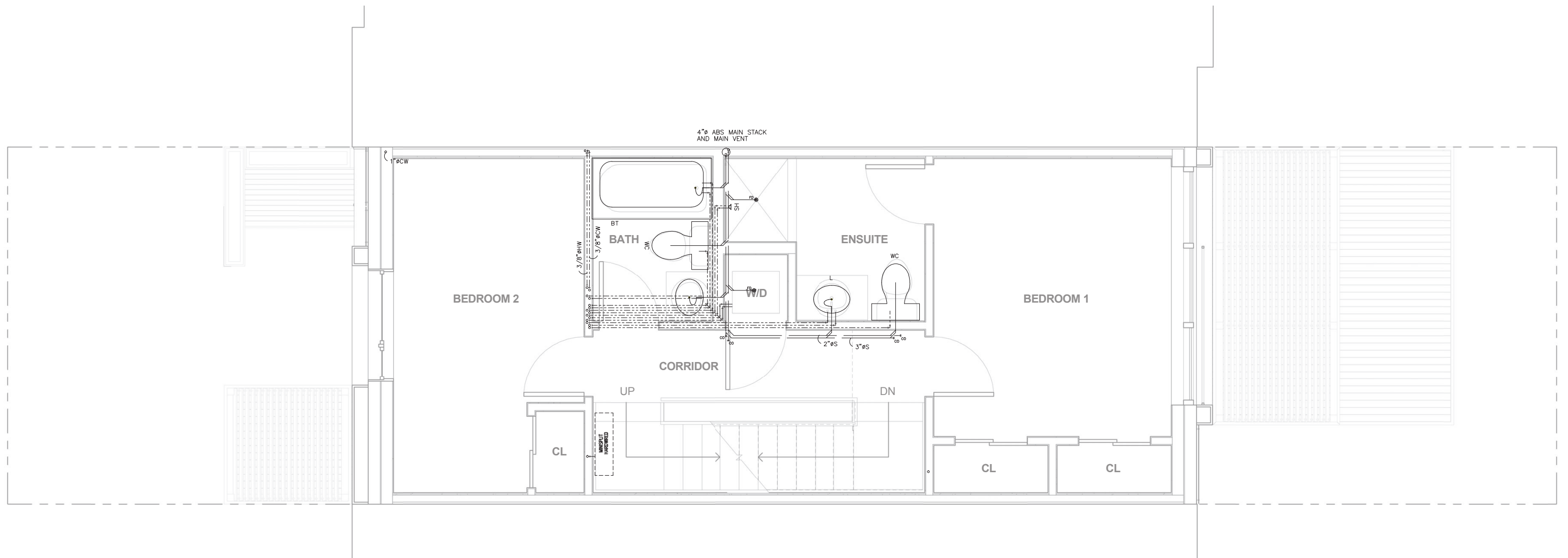

Plumbing Plan - Level Two  
Scale: 1/4" = 1'-0"



PLUMBING SYMBOL LEGEND		
PLUMBING FIXTURES	PLUMBING & DRAINAGE	PIPE FITTINGS
WC	— DCW — DOMESTIC COLD WATER	PIPE ELBOW
L	— HW — HOT WATER	ELBOW, UP
BT	- - - - SANITARY (BELOW FLOOR OR BURIED)	ELBOW, DOWN
SH	— RL — LIQUID REFRIGERANT	PIPE TEE
	CO  CLEANOUT PLUG	TEE, UP
	CO  CLEANOUT FLOOR	TEE, DOWN
	U  TRAP	BALL VALVE
	FD  FLOOR DRAIN	CHECK VALVE
		BACKFLOW PREVENTER



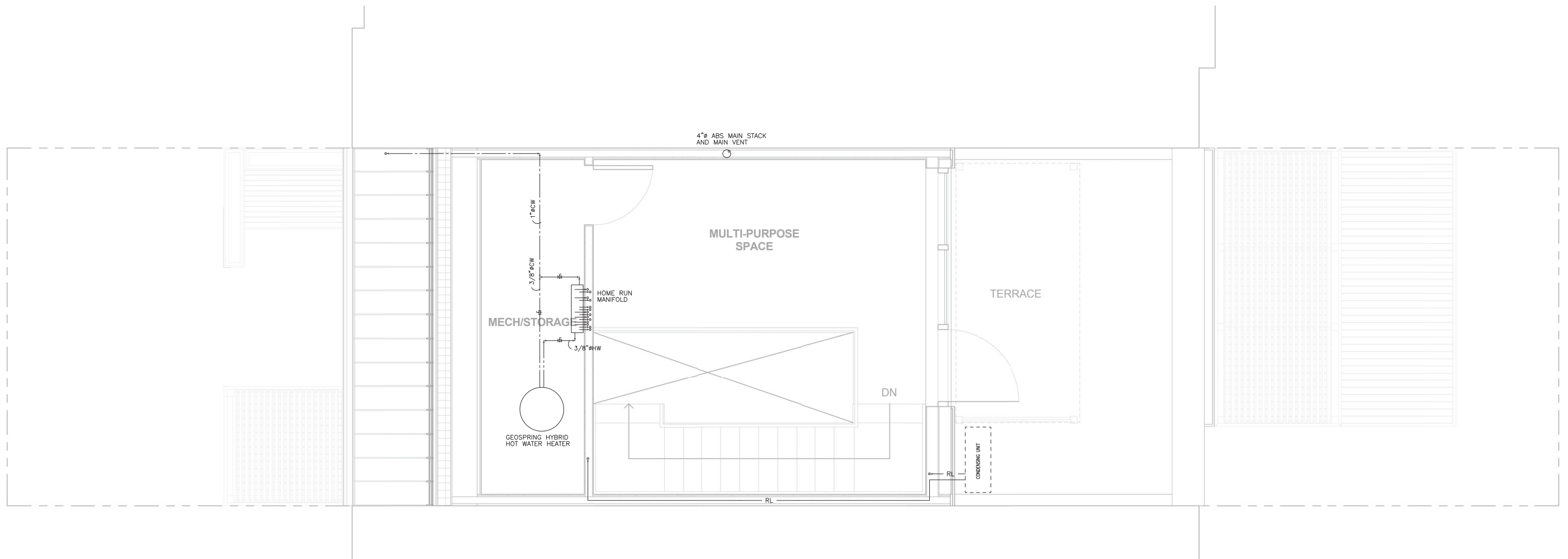

Plumbing Plan - Level Three  
Scale: 1/4" = 1'-0"



PLUMBING SYMBOL LEGEND		
PLUMBING FIXTURES	PLUMBING & DRAINAGE	PIPE FITTINGS
WC	— DCW — DOMESTIC COLD WATER	PIPE ELBOW
L	— HW — HOT WATER	ELBOW, UP
BT	- - - - SANITARY (BELOW FLOOR OR BURIED)	ELBOW, DOWN
SH	— RL — LIQUID REFRIGERANT	PIPE TEE
	CO  CLEANOUT PLUG	TEE, UP
	CO  CLEANOUT FLOOR	TEE, DOWN
	U  TRAP	BALL VALVE
	FD  FLOOR DRAIN	CHECK VALVE
		BACKFLOW PREVENTER

# 11.10 HARDWIRING LIGHTING PLANS

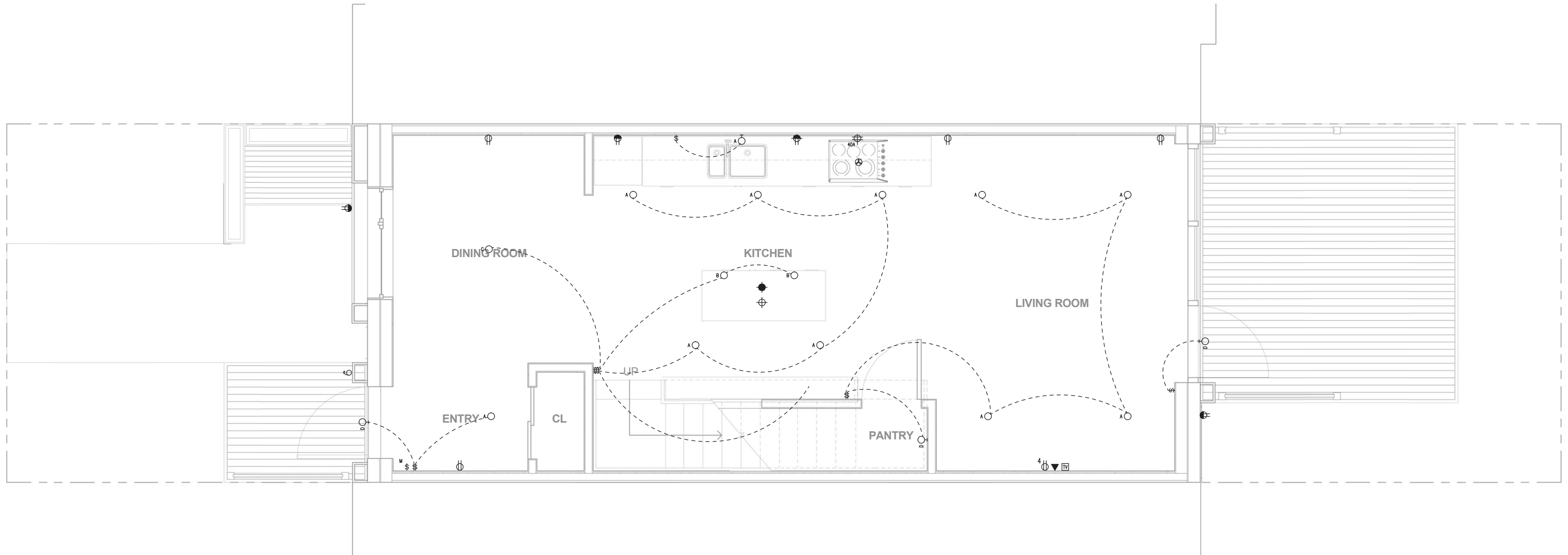

Electrical Plan - Level One  
Scale: 1/4" = 1'-0"



ELECTRICAL SYMBOL LEGEND			
<p><b>GENERAL POWER</b></p> <ul style="list-style-type: none"> <li>⊕ 15A, U-GROUND SINGLE RECEPTACLE</li> <li>⊕⊕ 15A, U-GROUND DUPLEX RECEPTACLE 4 INDICATES QUAD RECEPTACLE (DOUBLE DUPLEX)</li> <li>⊕⊕⊕ 15A, U-GROUND SINGLE OR DUPLEX RECEPTACLE MOUNTED ABOVE COUNTER OR 1200AUF</li> <li>⊕⊕⊕⊕ 15A, U-GROUND SINGLE INSULATED/ISOLATED GROUND RECEPTACLE - STANDARD MOUNTING HEIGHT OR MOUNTED ABOVE COUNTER OR 1200AUF</li> <li>⊕⊕⊕⊕⊕ 15A, U-GROUND DUPLEX INSULATED/ISOLATED GROUND RECEPTACLE - STANDARD MOUNTING HEIGHT OR MOUNTED ABOVE COUNTER OR 1200AUF</li> <li>⊕⊕⊕⊕⊕⊕ 120/208V/16/30 AMP DRYER OUTLET</li> <li>⊕⊕⊕⊕⊕⊕⊕ 120/208V/16/40 AMP RANGE OUTLET</li> </ul>	<p><b>LIGHTING</b></p> <ul style="list-style-type: none"> <li>⊕⊕⊕⊕⊕⊕ CEILING MOUNTED LUMINAIRE, PHILIPS LIGHTOWER CORE PRO LED (CP630K6)</li> <li>⊕⊕⊕⊕⊕⊕ CEILING MOUNTED LUMINAIRE, ACCESS LIGHTING INARI SILK CYLINDER PENDANT (94932 LED 4 BS OPL) (72932 LED 4 BS OPL)</li> <li>⊕⊕⊕⊕⊕⊕ CEILING MOUNTED LUMINAIRE, ACCESS LIGHTING NITROGEN BALL PENDANT (23952)</li> <li>⊕⊕⊕⊕⊕⊕ CEILING MOUNTED LUMINAIRE, PHILIPS GLASSLITE (CAMRGO)</li> <li>⊕⊕⊕⊕⊕⊕ WALL MOUNTED LUMINAIRE, BROWNLEE TASK UTILITY (5080 48 32L E54) (5020 24 CEC 217L WA ESS)</li> <li>⊕⊕⊕⊕⊕⊕ WALL MOUNTED LUMINAIRE, BROWNLEE BATH AND VANITY UTILITY (5020 24 CEC 217L WA ESS)</li> <li>⊕⊕⊕⊕⊕⊕ WALL MOUNTED LUMINAIRE, BROWNLEE BATH AND VANITY UTILITY (5020 36 CEC 225L WA ESS)</li> <li>⊕⊕⊕⊕⊕⊕ WALL MOUNTED LUMINAIRE, ACCESS LIGHTING BRICK WET LOCATION (20450)</li> </ul>	<p><b>LIGHTING CONTROL</b></p> <ul style="list-style-type: none"> <li>⊕⊕⊕⊕⊕⊕ ONE, TWO, THREE AND FOUR GANG SINGLE POLE TOGGLE SWITCHES</li> <li>⊕ 3-WAY SWITCH</li> <li>⊕* MASTER SWITCH</li> </ul> <p><b>FIRE ALARM SYSTEM</b></p> <ul style="list-style-type: none"> <li>⊕⊕⊕⊕⊕⊕ SMOKE DETECTOR - WALL OR CEILING MOUNTED</li> <li>⊕⊕⊕⊕⊕⊕ CARBON MONOXIDE DETECTOR - WALL OR CEILING MOUNTED</li> </ul> <p><b>EQUIPMENT CONNECTIONS AND CONTROLS</b></p> <ul style="list-style-type: none"> <li>⊕⊕⊕⊕⊕⊕ FAN CONNECTION AS SPECIFIED</li> </ul>	<p><b>COMMUNICATIONS</b></p> <ul style="list-style-type: none"> <li>⊕⊕⊕⊕⊕ TELEVISION OUTLET - WALL MOUNTED OR MOUNTED ABOVE COUNTER</li> <li>⊕⊕⊕⊕⊕ TELEPHONE OUTLET - WALL MOUNTED OR MOUNTED ABOVE COUNTER</li> <li>⊕⊕⊕⊕⊕ DATA OUTLET - WALL MOUNTED OR MOUNTED ABOVE COUNTER</li> <li>⊕⊕⊕⊕⊕ SIGNAL BELL C/W TRANSFORMER</li> </ul>

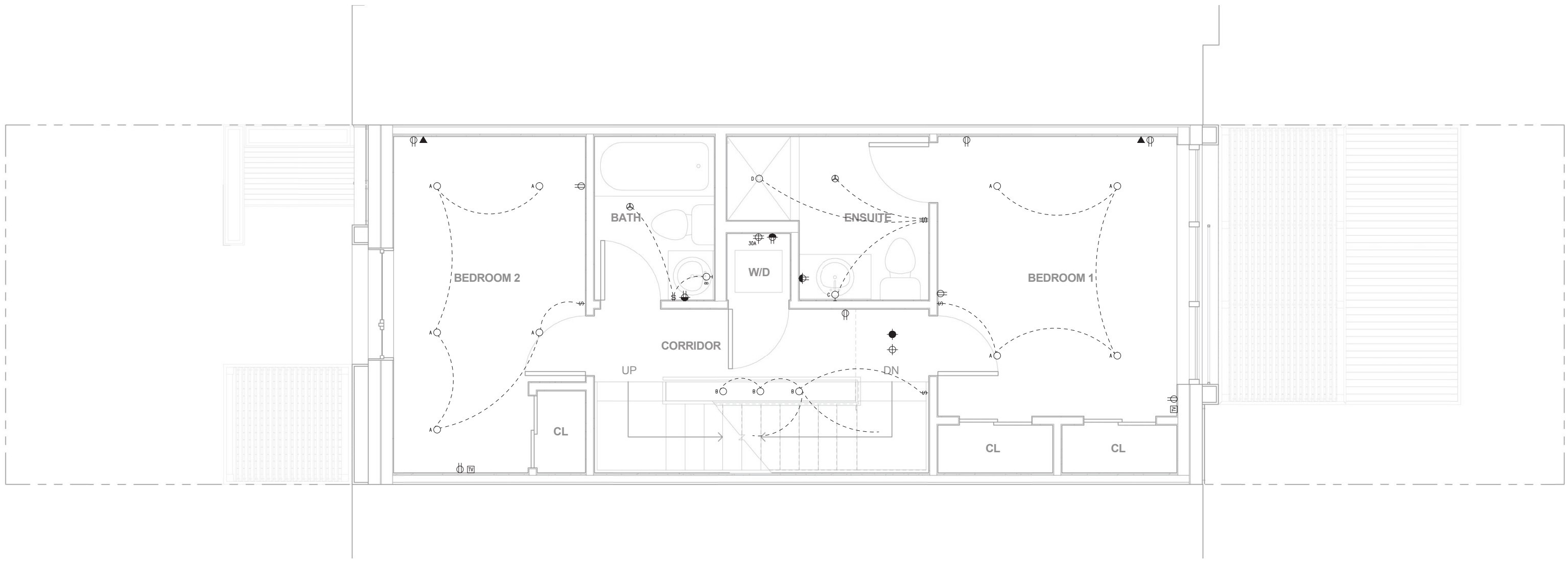

Electrical Plan - Level Two  
Scale: 1/4" = 1'-0"



ELECTRICAL SYMBOL LEGEND			
<p><b>GENERAL POWER</b></p> <ul style="list-style-type: none"> <li>⊕ 15A, U-GROUND SINGLE RECEPTACLE</li> <li>⊕⊕ 15A, U-GROUND DUPLEX RECEPTACLE 4 INDICATES QUAD RECEPTACLE (DOUBLE DUPLEX)</li> <li>⊕⊕⊕ 15A, U-GROUND SINGLE OR DUPLEX RECEPTACLE MOUNTED ABOVE COUNTER OR 1200AFF</li> <li>⊕⊕⊕⊕ 15A, U-GROUND SINGLE INSULATED/ISOLATED GROUND RECEPTACLE - STANDARD MOUNTING HEIGHT OR MOUNTED ABOVE COUNTER OR 1200AFF</li> <li>⊕⊕⊕⊕⊕ 15A, U-GROUND DUPLEX INSULATED/ISOLATED GROUND RECEPTACLE - STANDARD MOUNTING HEIGHT OR MOUNTED ABOVE COUNTER OR 1200AFF</li> <li>⊕⊕⊕⊕⊕ 120/208V/16/30 AMP DRYER OUTLET</li> <li>⊕⊕⊕⊕⊕ 120/208V/16/40 AMP RANGE OUTLET</li> </ul>	<p><b>LIGHTING</b></p> <ul style="list-style-type: none"> <li>⊕⊕⊕⊕⊕ CEILING MOUNTED LUMINAIRE, PHILIPS LIGHTOWER CORE PRO LED (CP630K6)</li> <li>⊕⊕⊕⊕⊕ CEILING MOUNTED LUMINAIRE, ACCESS LIGHTING INARI SILK CYLINDER PENDANT (94932 LED 4 BS OPL) (72932 LED 4 BS OPL)</li> <li>⊕⊕⊕⊕⊕ CEILING MOUNTED LUMINAIRE, ACCESS LIGHTING NITROGEN BALL PENDANT (23952)</li> <li>⊕⊕⊕⊕⊕ CEILING MOUNTED LUMINAIRE, PHILIPS GLASSLITE (CAMRD)</li> <li>⊕⊕⊕⊕⊕ WALL MOUNTED LUMINAIRE, BROWNLEE TASK UTILITY (5080 48 32L E54) (5020 24 CEC 217L WA ESS)</li> <li>⊕⊕⊕⊕⊕ WALL MOUNTED LUMINAIRE, BROWNLEE BATH AND VANITY UTILITY (5020 24 CEC 217L WA ESS)</li> <li>⊕⊕⊕⊕⊕ WALL MOUNTED LUMINAIRE, BROWNLEE BATH AND VANITY UTILITY (5020 36 CEC 225L WA ESS)</li> <li>⊕⊕⊕⊕⊕ WALL MOUNTED LUMINAIRE, ACCESS LIGHTING BRICK WET LOCATION (20450)</li> </ul>	<p><b>LIGHTING CONTROL</b></p> <ul style="list-style-type: none"> <li>⊕⊕⊕⊕⊕ ONE, TWO, THREE AND FOUR GANG SINGLE POLE TOGGLE SWITCHES</li> <li>⊕⊕⊕ 3-WAY SWITCH</li> <li>⊕⊕⊕ MASTER SWITCH</li> </ul> <p><b>FIRE ALARM SYSTEM</b></p> <ul style="list-style-type: none"> <li>⊕⊕⊕⊕⊕ SMOKE DETECTOR - WALL OR CEILING MOUNTED</li> <li>⊕⊕⊕⊕⊕ CARBON MONOXIDE DETECTOR - WALL OR CEILING MOUNTED</li> </ul> <p><b>EQUIPMENT CONNECTIONS AND CONTROLS</b></p> <ul style="list-style-type: none"> <li>⊕⊕⊕⊕⊕ FAN CONNECTION AS SPECIFIED</li> </ul>	<p><b>COMMUNICATIONS</b></p> <ul style="list-style-type: none"> <li>⊕⊕⊕⊕ TELEVISION OUTLET - WALL MOUNTED OR MOUNTED ABOVE COUNTER</li> <li>⊕⊕⊕ TELEPHONE OUTLET - WALL MOUNTED OR MOUNTED ABOVE COUNTER</li> <li>⊕⊕⊕ DATA OUTLET - WALL MOUNTED OR MOUNTED ABOVE COUNTER</li> <li>⊕⊕⊕ SIGNAL BELL C/W TRANSFORMER</li> </ul>

# 11.10 HARDWIRING LIGHTING PLANS

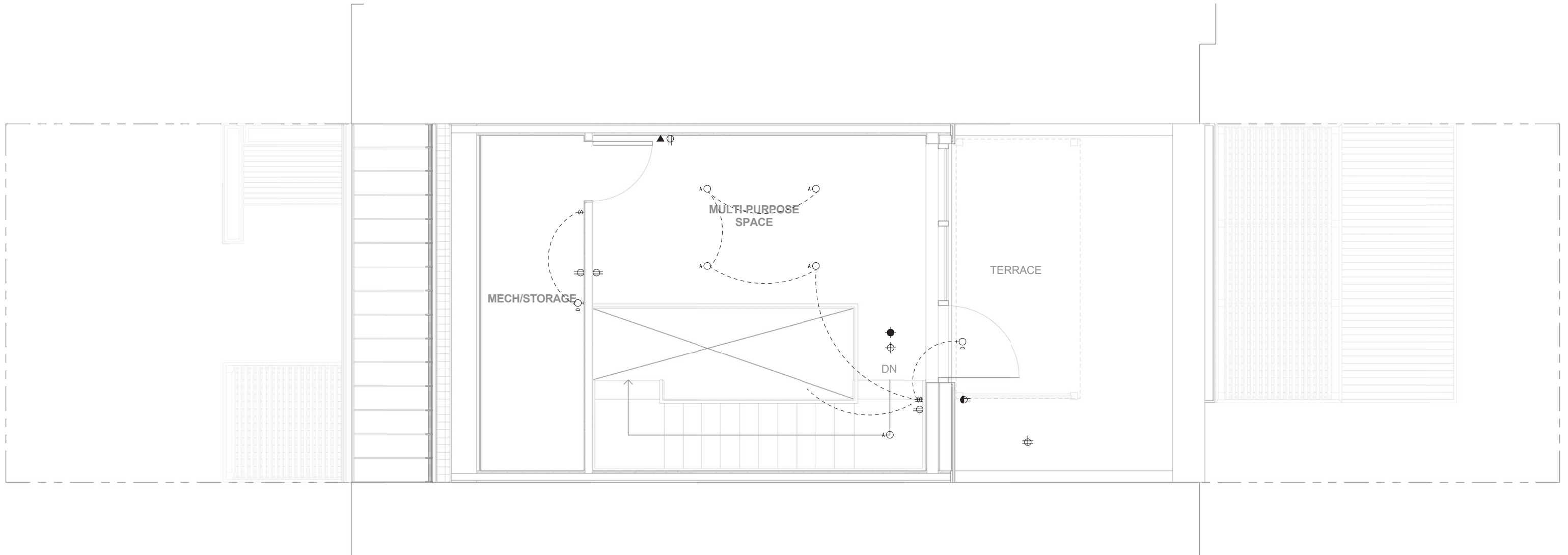

Electrical Plan - Level One  
Scale: 1/4" = 1'-0"



ELECTRICAL SYMBOL LEGEND			
GENERAL POWER	LIGHTING	LIGHTING CONTROL	COMMUNICATIONS
<ul style="list-style-type: none"> <li>⊕ 15A, U-GROUND SINGLE RECEPTACLE</li> <li>⊕⊕ 15A, U-GROUND DUPLEX RECEPTACLE 4 INDICATES QUAD RECEPTACLE (DOUBLE DUPLEX)</li> <li>⊕⊕⊕ 15A, U-GROUND SINGLE OR DUPLEX RECEPTACLE MOUNTED ABOVE COUNTER OR 1200AFF</li> <li>⊕⊕⊕⊕ 15A, U-GROUND SINGLE INSULATED/ISOLATED GROUND RECEPTACLE - STANDARD MOUNTING HEIGHT OR MOUNTED ABOVE COUNTER OR 1200AFF</li> <li>⊕⊕⊕⊕ 15A, U-GROUND DUPLEX INSULATED/ISOLATED GROUND RECEPTACLE - STANDARD MOUNTING HEIGHT OR MOUNTED ABOVE COUNTER OR 1200AFF</li> <li>⊕⊕⊕⊕⊕ 120/208V/16/30 AMP DRYER OUTLET</li> <li>⊕⊕⊕⊕⊕ 120/208V/16/40 AMP RANGE OUTLET</li> </ul>	<ul style="list-style-type: none"> <li>⊕⊕⊕⊕⊕ CEILING MOUNTED LUMINAIRE, PHILIPS LIGHTQUIET CORE PRO LED (CP630K6)</li> <li>⊕⊕⊕⊕⊕ CEILING MOUNTED LUMINAIRE, ACCESS LIGHTING INARI SILK CYLINDER PENDANT (94932 LED 4 BS OPL) (72932 LED 4 BS OPL)</li> <li>⊕⊕⊕⊕⊕ CEILING MOUNTED LUMINAIRE, ACCESS LIGHTING NITROGEN BALL PENDANT (23952)</li> <li>⊕⊕⊕⊕⊕ CEILING MOUNTED LUMINAIRE, PHILIPS GLASSLITE (CAMRGD)</li> <li>⊕⊕⊕⊕⊕ WALL MOUNTED LUMINAIRE, BROWNLEE TASK UTILITY (5080 48 32L ES4) (5020 24 CEC 217L WA ESS)</li> <li>⊕⊕⊕⊕⊕ WALL MOUNTED LUMINAIRE, BROWNLEE BATH AND VANITY UTILITY (5020 24 CEC 217L WA ESS)</li> <li>⊕⊕⊕⊕⊕ WALL MOUNTED LUMINAIRE, BROWNLEE BATH AND VANITY UTILITY (5020 36 CEC 225L WA ESS)</li> <li>⊕⊕⊕⊕⊕ WALL MOUNTED LUMINAIRE, ACCESS LIGHTING BRICK WET LOCATION (20450)</li> </ul>	<ul style="list-style-type: none"> <li>⊕⊕⊕⊕⊕ ONE, TWO, THREE AND FOUR GANG SINGLE POLE TOGGLE SWITCHES</li> <li>⊕⊕⊕ 3-WAY SWITCH</li> <li>⊕⊕⊕ MASTER SWITCH</li> </ul> <p><b>FIRE ALARM SYSTEM</b></p> <ul style="list-style-type: none"> <li>⊕⊕⊕⊕⊕ SMOKE DETECTOR - WALL OR CEILING MOUNTED</li> <li>⊕⊕⊕⊕⊕ CARBON MONOXIDE DETECTOR - WALL OR CEILING MOUNTED</li> </ul> <p><b>EQUIPMENT CONNECTIONS AND CONTROLS</b></p> <ul style="list-style-type: none"> <li>⊕⊕⊕⊕⊕ FAN CONNECTION AS SPECIFIED</li> </ul>	<ul style="list-style-type: none"> <li>⊕⊕⊕⊕ TELEVISION OUTLET - WALL MOUNTED OR MOUNTED ABOVE COUNTER</li> <li>⊕⊕⊕⊕ TELEPHONE OUTLET - WALL MOUNTED OR MOUNTED ABOVE COUNTER</li> <li>⊕⊕⊕⊕ DATA OUTLET - WALL MOUNTED OR MOUNTED ABOVE COUNTER</li> <li>⊕⊕⊕⊕ SIGNAL BELL C/W TRANSFORMER</li> </ul>

# 11.11 FLASHING & AIR SEALING DETAILS

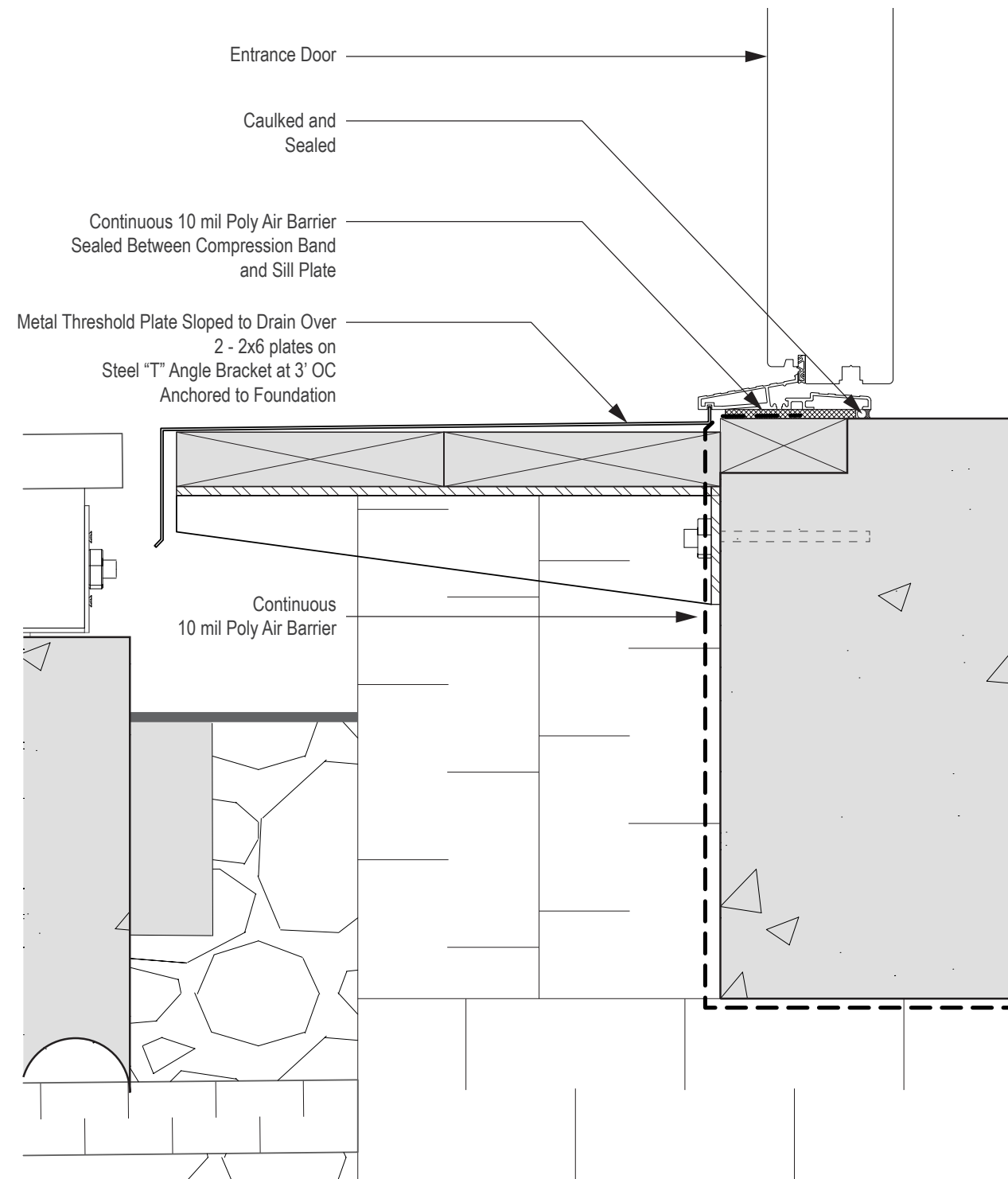

Detail 1 - Entry Door Sill Detail  
Scale: 3" = 1'-0"

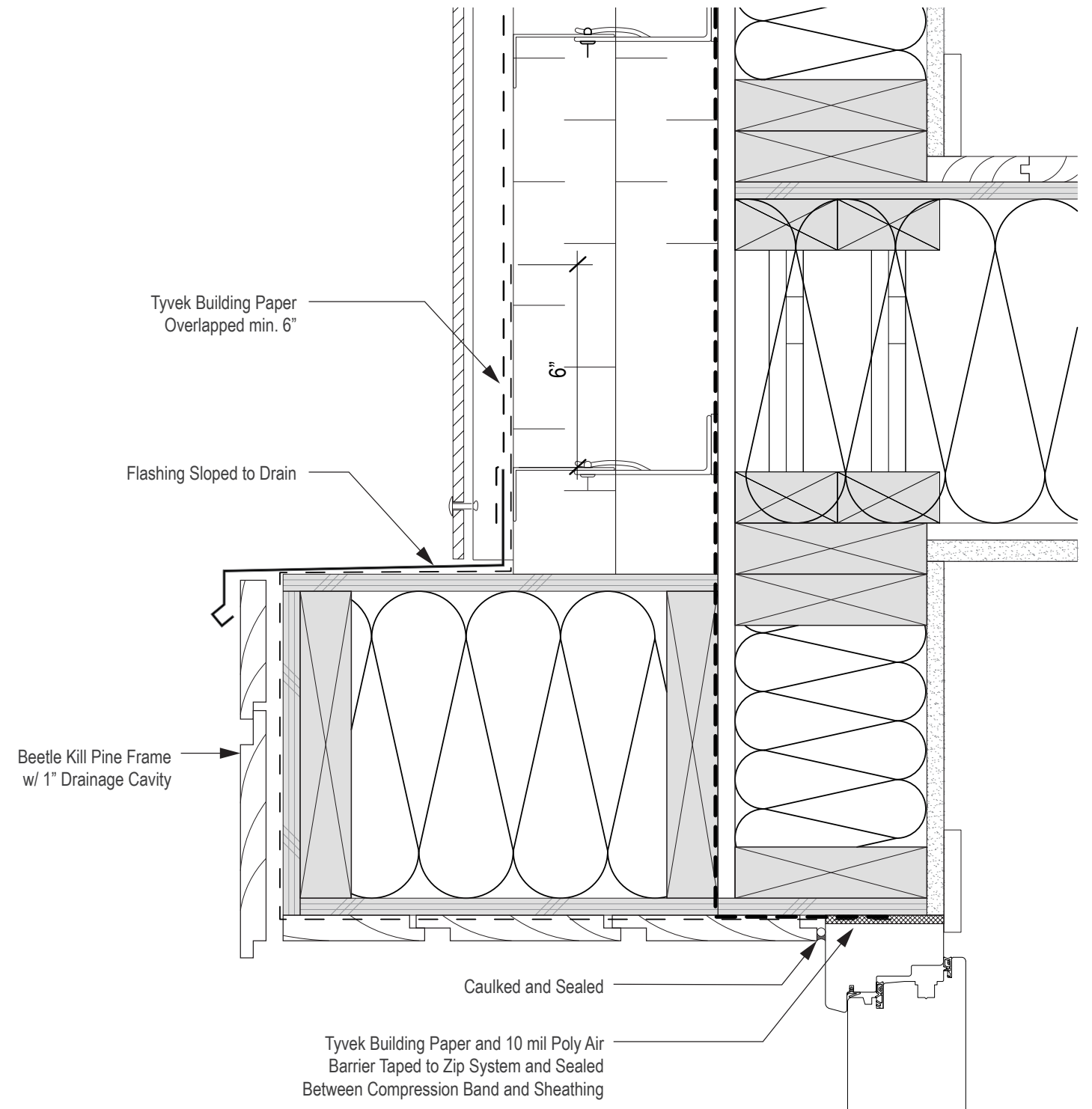

Detail 2 - Entry Door Header Detail  
Scale: 3" = 1'-0"

# 11.11 FLASHING & AIR SEALING DETAILS

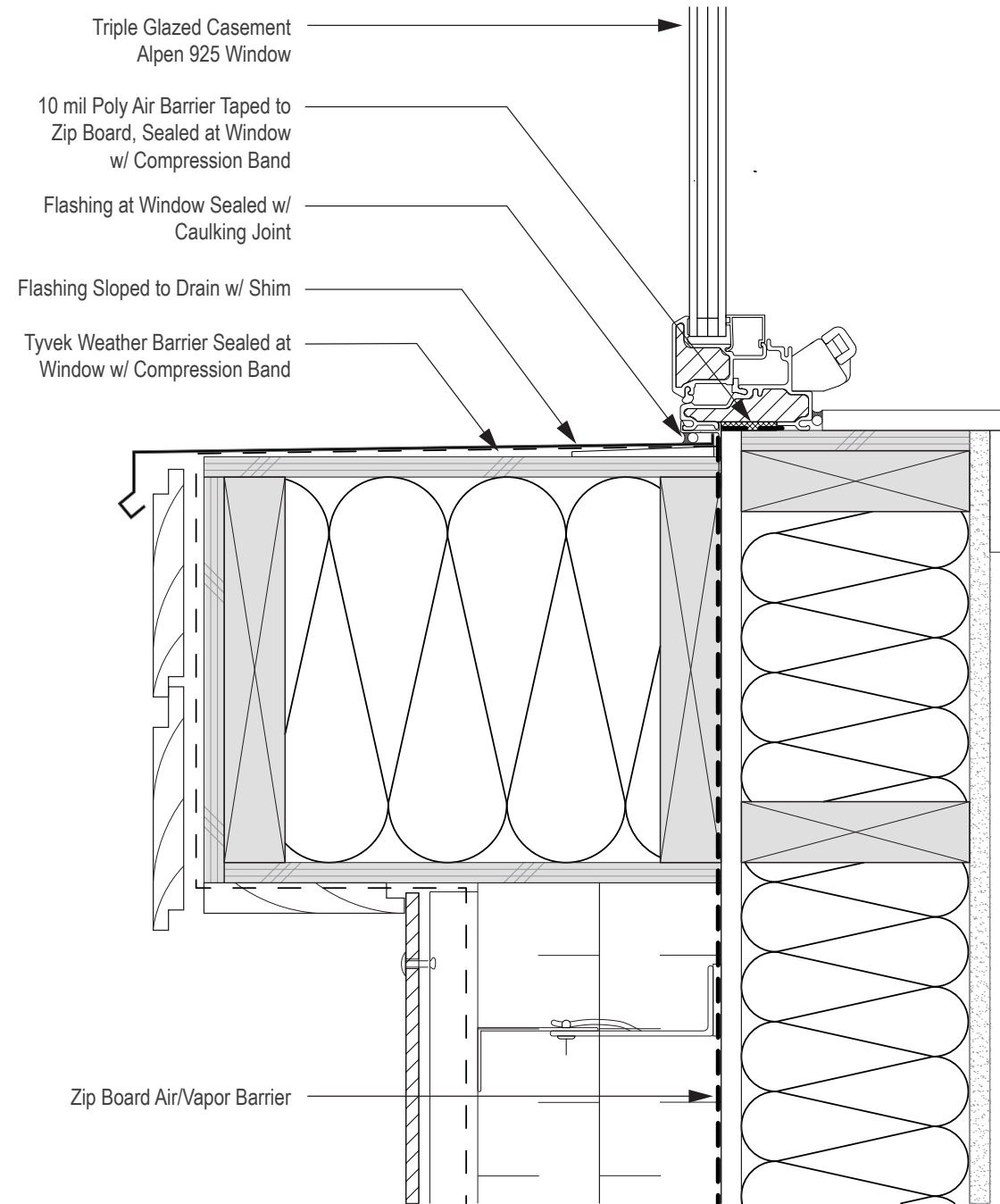

Detail 3 - Window Sill Detail  
Scale: 3" = 1'-0"

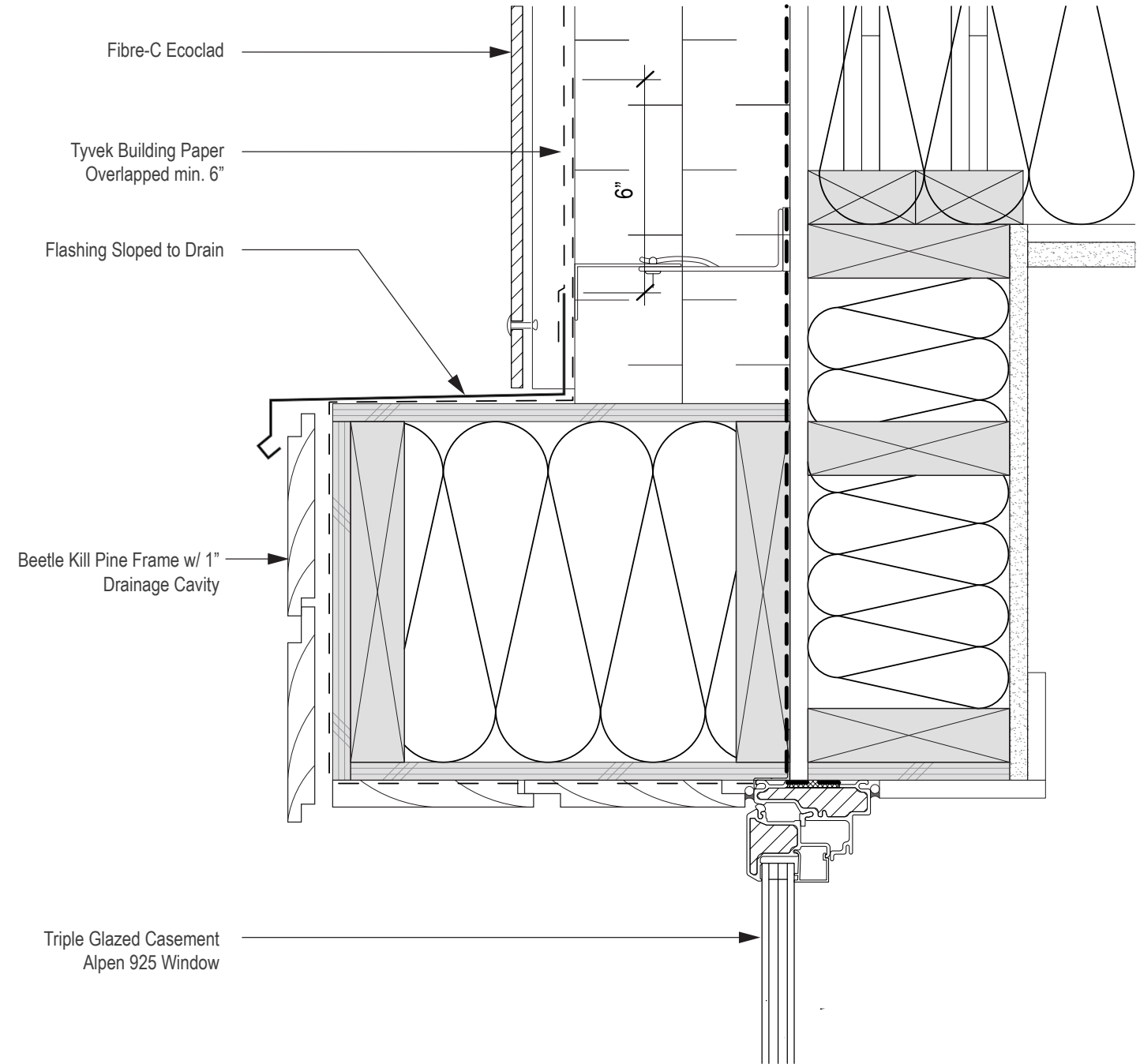

Detail 4 - Window Header Detail  
Scale: 3" = 1'-0"

## 12.1 IBHS FORTIFIED FOR SAFER LIVING CHECKLIST

### Winter Weather

As a by-product of pursuing Passive House certification, the Harvest Home's envelope is highly resilient to winter weather. The R-values for walls, roof and slabs promise to reduce heating load, while on-site photovoltaic panels have the potential to offset nearly all energy requirements.

- a. The flat roof is accessible for snow removal and is calculated for high snow load, (10-12") of new snow / 5 lbs per square foot of roof space.
- b. Air tightness prevents the formation of ice dams.
- c. The mechanical/storage room is conditioned.
- d. No pipes are installed in external walls and unheated spaces, and all exterior piping is below ground at non-frozen depth.
- e. The only penetrations are from the ERV and will be well insulated.
- f. The heat source is within the conditioned space.

### Hail Threat

The home features a galvanized metal standing seam roof to achieve a high coefficient of reflectance while protecting the membrane and insulation layers of the roof assembly from potential damage due to hail among other natural events. All apertures of the home are housed within a projected wood clad frame providing additional protection to vulnerable vertical surfaces.



The Harvest Home Site Relative to Denver's Floodplain ([www.udfcd.gisworkshop.com](http://www.udfcd.gisworkshop.com))

### Flood Threat

The Harvest Home's Curtis Park Neighborhood site is situated well outside Denver's designated floodplain territory. According to Denver's Urban Drainage and Flood Control District<sup>1</sup>, a narrow floodplain exists extending North-West over a mile away.

### Energy Generation

The residence not only provides consideration for the future installment of photovoltaic panels, but also an on-site generator to be housed at the South terrace. Generator ready to be plugged on the terrace. The potential PV array is intended to be able to override the system feed and directly supply on-site harvested solar energy.

## 12.2 LEED-H CERTIFICATION

The Harvest Home aims to achieve LEED Platinum, the highest possible LEED certification level. To achieve LEED Platinum a point score of 90 is required, however LEED rewards homes with compact geometry for their inherent efficiency in resource use. Therefore due to the Harvest Home's small footprint, a point adjustment factor of -8 is applied resulting in a point score of 82 being required for LEED Platinum.

The Harvest Home easily meets LEED Platinum requirements with a total point score of 91. For the complete LEED Checklist, refer to Appendix 12. The Harvest Home performs strongly in all eight LEED categories.

### **Innovation and Design Process**

An integrated design process was followed by the student and faculty team with several charrettes and coordination sessions allowing iterative design, simulation analysis and revision.

### **Location and Linkages**

The Harvest Home is located on currently vacant, yet previously developed urban site with ample existing infrastructure. The site is also located adjacent to a local community garden.

### **Sustainable Sites**

The building will occupy a small portion of the site with the remaining area to be allocated to native, drought tolerant plants. All site landscape finishes are to be at least 70% permeable.

### **Water Efficiency**

Rainwater is to be collected in two on-site cisterns for outdoor use. High efficiency fixtures are installed throughout the home's interior.

### **Energy and Atmosphere**

The home will achieve a maximum HERS rating of 40. All hot water equipment is centrally located in the home to minimize pipe runs. All plumbing lines are insulated to R-4 (RSI 0.7).

### **Materials and Resources**

All timber used in the home's construction is FSC certified and all interior finishes are low VOC. The rock wool insulation used in the exterior walls features a minimum recycled content of 20%.

### **Indoor Environment Quality**

An Energy Recovery Ventilator (ERV) is to be installed and the HVAC system will provide appropriate dehumidification.

### **Awareness and Education**

Given the nature of the competition proposal and the Denver Super Efficient Housing Challenge, the building will be highly publicized and web information will be available.



## 12.3 PASSIVE HOUSE QUALITY INSPECTION CHECKLIST

### Slab Inspection (Pre-pour)

- a. Continuous under-slab insulation
- b. Continuous poly air-barrier

### Walls / Ceiling

- a. Sub-slab poly air-barrier taped to ZIP system wall
- b. ZIP system taped seam inspection
- c. ZIP system transition to ceiling
- d. Bottom plate penetrations
- e. Ceiling taped seam inspection

### MEP Rough-in

- a. Wall and ceiling penetrations covered and taped

### PHIUS+ Rating

- a. Pre-pour
- b. Insulation (thermal imaging)
- c. Final

### ENERGY STAR Rating

- a. Minimum Grade 2 insulation batts required
- b. Water resistant drywall in kitchen and bath walls

### Air-sealing Targets (Duclos Method)

- a. Initial test after slab, wall, ceilings closed in, before window and door cutouts: 0.25 ACH50
- b. Second test after window and door insulation, before exterior insulation: 0.45 ACH50
- c. Third test after MEP rough-in, before exterior insulation: 0.60 ACH50
- d. Final target: 0.60 ACH50

For additional information regarding the Passive House Quality Inspection Checklist, refer to Appendix 12.





