

**DOE Bioenergy Technologies Office (BETO)
2021 Project Peer Review**

**Towards Economical Cell-free
Isobutanol Production**

Date: March 10th, 2021

Technology Area Session: Biochemical Conversion and Lignin Utilization

Principal Investigator: Tyler Korman, PhD

Organization: Invizyne Technologies, Inc.

Project Overview

Biocommodity and Biofuel Production from Sugar

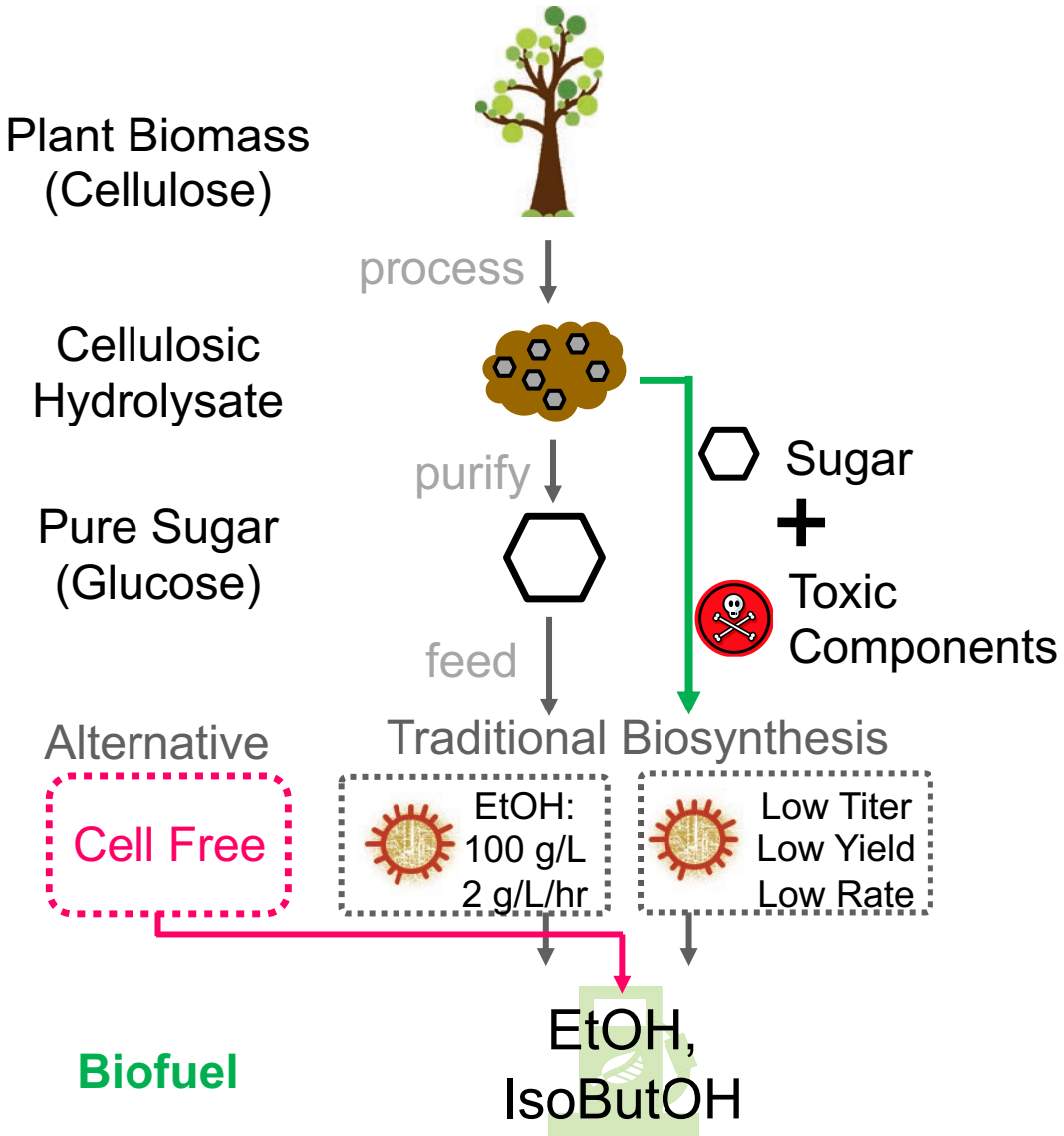

- Biomass derived sugars can be used by engineered microbes to make fuels and chemicals
 - Works well for pure glucose which is more costly and less flexible
 - Cellulosic sugars can come from any biomass but toxic components limit use by microbes

Alternative methods should be explored to improve cellulosic utilization and conversion

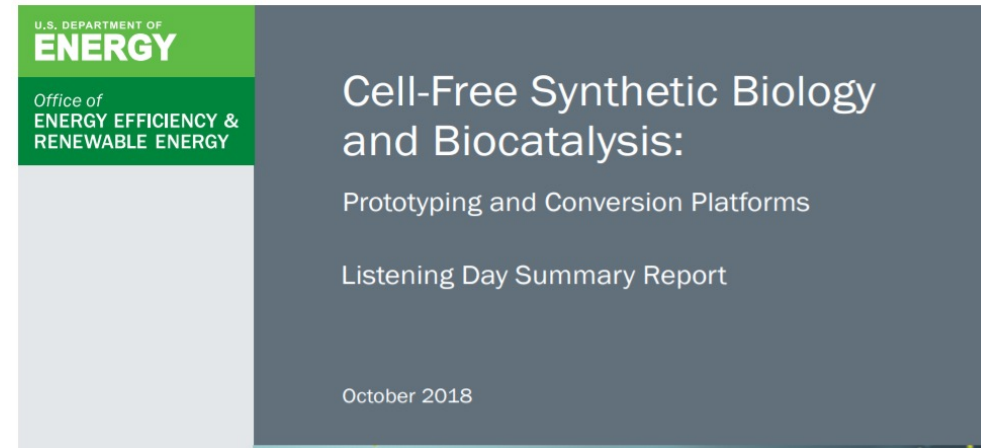

In 2018 BETO recognized that cell-free biological systems show promise to advance the bioeconomy warranting further investment to de-risk this important technology

Project Overview

Biocommodity and Biofuel Production from Sugar

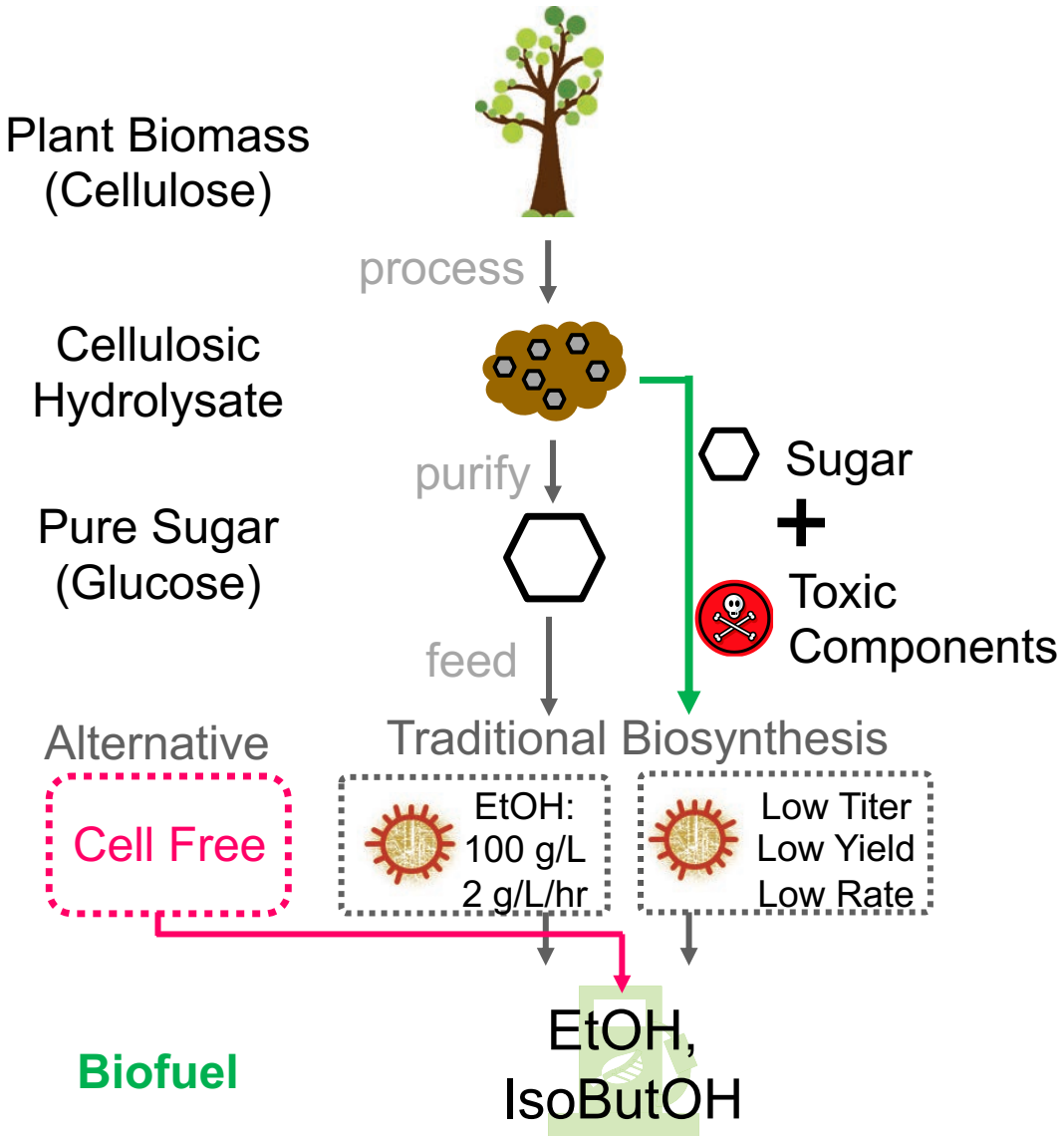

- Biomass derived sugars can be used by engineered microbes to make fuels and chemicals
 - Works well for pure glucose which is more costly and less flexible
 - Cellulosic sugars can come from any biomass but toxic components limit use by microbes

Alternative methods should be explored to improve cellulosic utilization and conversion

- Using only enzymes (cell-free) instead of the whole microbes may improve conversion of cellulosic sugars into useful chemicals
 - Benefits include higher titer, yields, and productivity compared to cells
 - Cell-free is an emerging technology and must be validated at scale and with cellulosic feedstocks

End of Project Milestone: 500 g/L isobutanol

- **20x higher than cell-based methods**

Project Overview

Biocommodity and Biofuel Production from Sugar

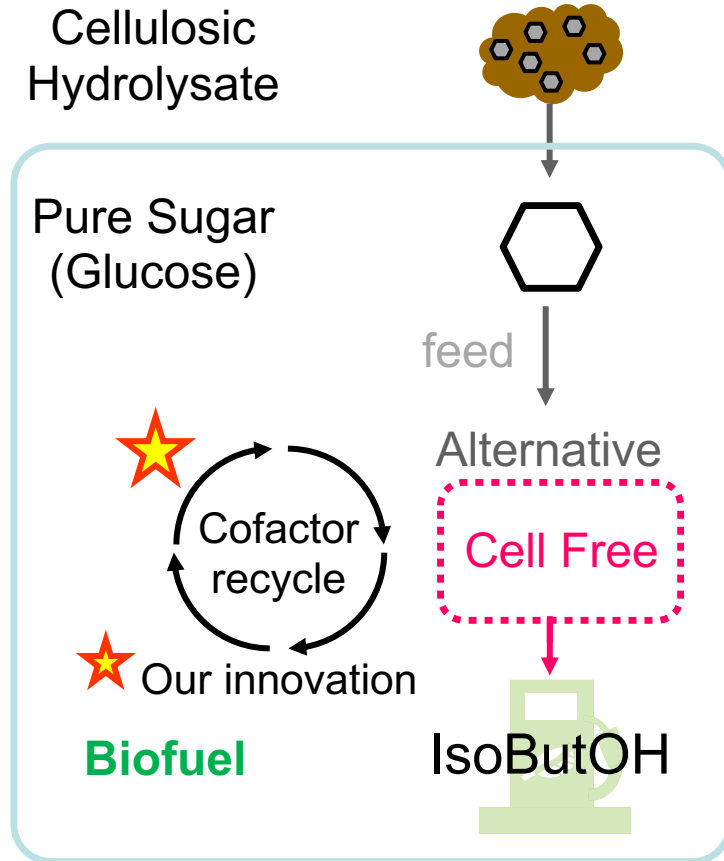

Past work – Baseline system
(already >10x higher titer than cell-based systems)

Because we start at higher titers than cells, even a 25-50% increase in titer would be significant!

- We want to build on our previous high impact work:

Highlights of Past Work

- ★ New ATP and Redox balancing systems that enable cell-free catalysis over many days to reach high titers
- Incorporation of stable enzymes enables extremely high titers (*already* 10x cell-based)
- Ability to quickly make numerous products from low-cost inputs (e.g. glucose) at titers 10 to 100x higher than any reported in living cells

Overall Goals of Current Work

- Increase overall titers to 500 g/L
- Incorporate cellulosic sugar
- Decrease cost by using less/more stable/more active protein
- Decrease cost by using cheaper cofactors***

Effect of Cofactor Choice on Isobutanol Cost

TEA assumption: 300,000 L @ 4g/L/hr for 4 days with 10 g/L enzyme

Cofactor	\$/kg	<u>Isobutanol</u> (\$/kg)	% of total cost
NADP	\$9000	\$22	85%
NAD	\$200	\$3.57	13 %

1 – Management

Logistics

Invizyne and UCLA (Bowie Lab) will perform research tasks independently and share important results in a collaborative approach to reach all milestones. Materials and protocols will be shared to the extent possible. This is especially important for tasks to reach Go/No-Go and Final Milestones.

Task
Breakdown

Invizyne

Cellulosic Hydrolysate Tasks (1,9,12,13)
Enzyme Rate/Cofactor Utilization Tasks (4,6)
Protein Production Tasks (7,10)

UCLA

Pure Glucose Tasks (2,8,11)
Enzyme Rate/Stability Tasks (3,4,5)
Protein Production Tasks (7,10)

Risks

- 1. Enzyme stability/cost:** Enzyme engineering for faster/more stable enzymes lowers load and cost
- 2. Cofactor stability/cost:** System engineering to use NAD(H) significantly lowers cost
- 3. Feedstock usage:** Focus on different feedstocks ensure problems with one will inform the other
- 4. Reaction scale:** Collaboration and outsourcing ensures material for sufficient troubleshooting

internal

- Invizyne and UCLA PIs have a strong working relationship over 10 years. The two groups have weekly virtual meetings to discuss results, challenges, and future directions to ensure all milestones are met.

Team
Communication

external

- Quarterly reports and virtual quarterly update meetings with the Program Manager/Monitor help identify risks and relay strategies to mitigate problems with the awarding agency.
- Invizyne has a strong relationship with team at NREL (Bomble Lab) on a different but related BETO project. The PIs discuss quarterly high level challenges, especially related to feedstock, that effect both projects. Collaboration will help normalize results from different groups using different but similar feedstocks.

2 – Approach

1st Generation Synthetic Biology: Cells as a Factory

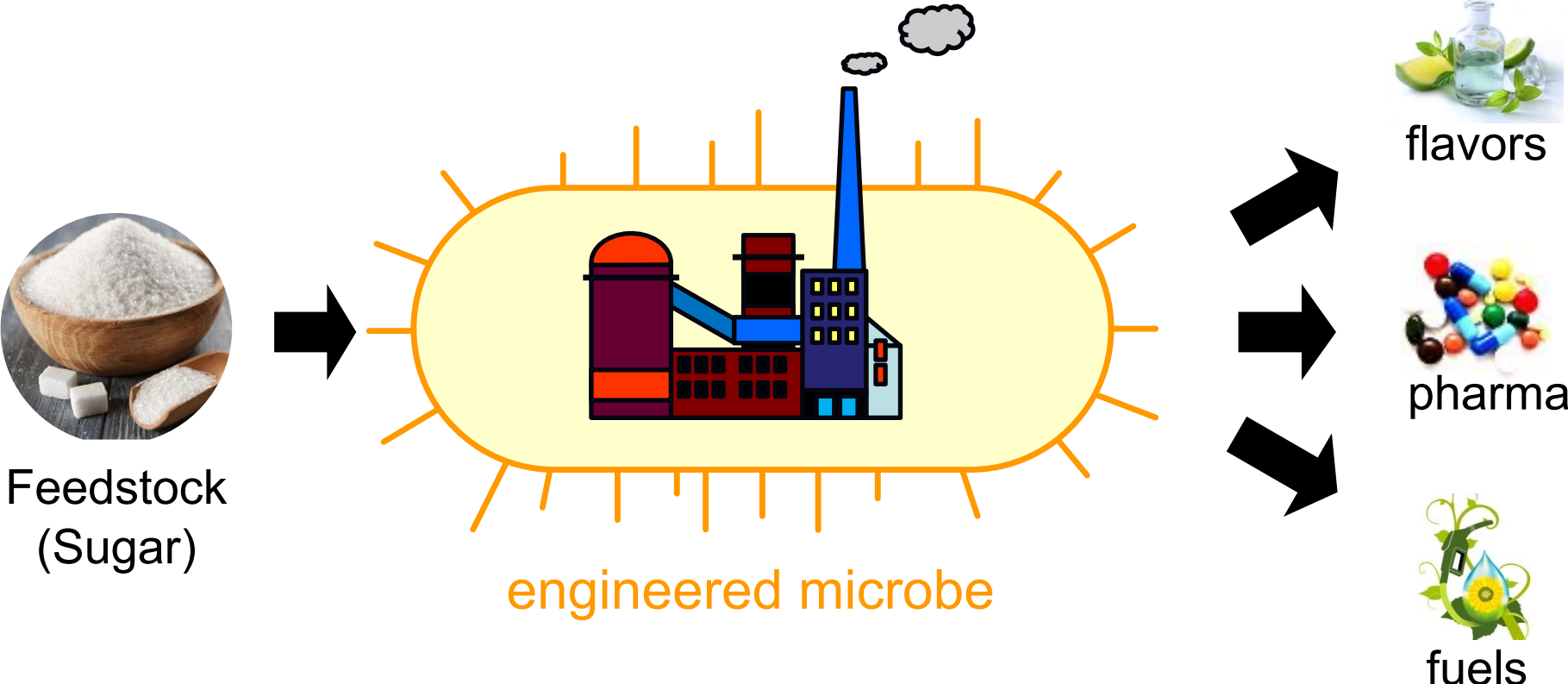

The Problem with Cells

- Background metabolism lowers yield and titers
- Toxic products and Intermediates
- Unwanted side-effects

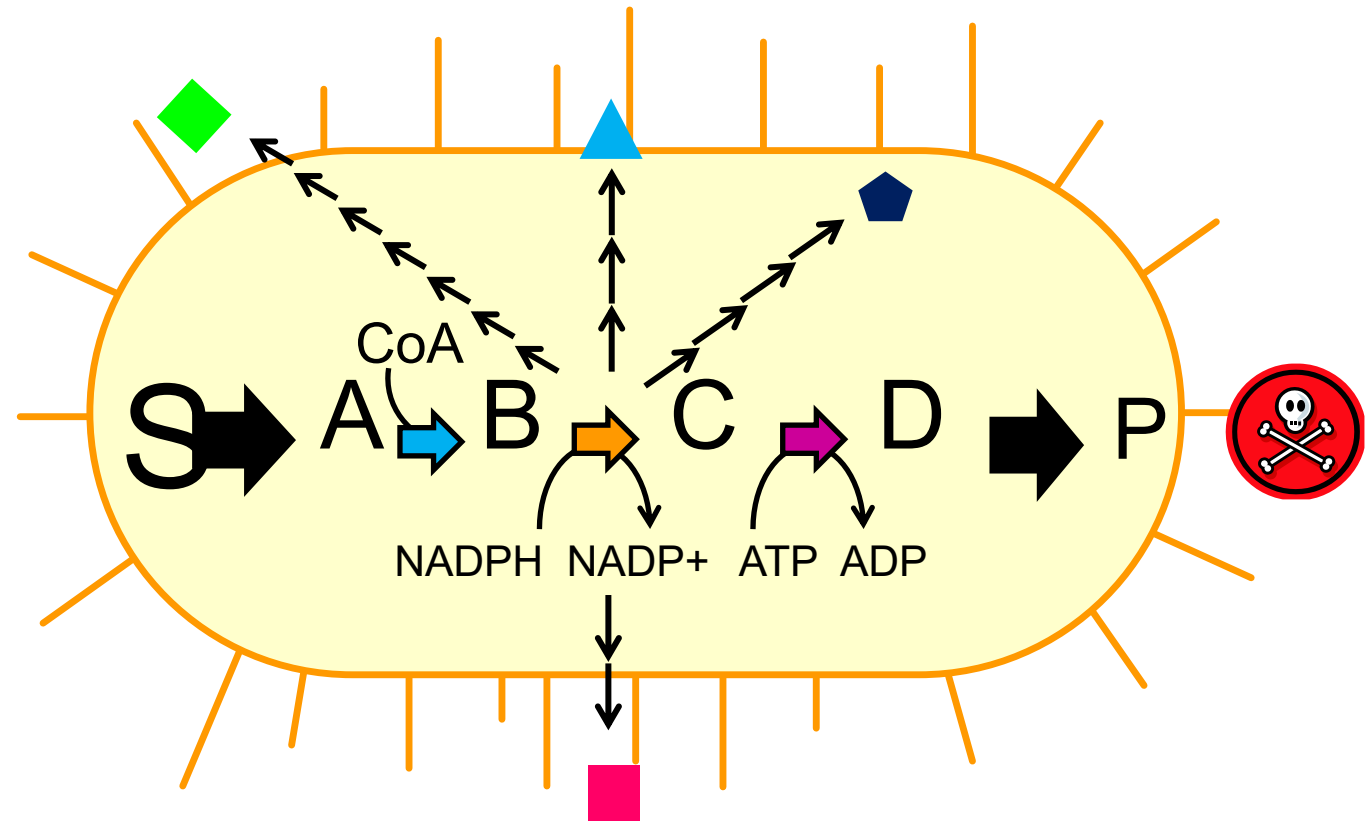

*

Unknown/unwanted outcomes and long DBT cycles makes cell engineering difficult, slow, and costly

2 – Approach

Invizyne's Approach: Simplify Biocatalysis

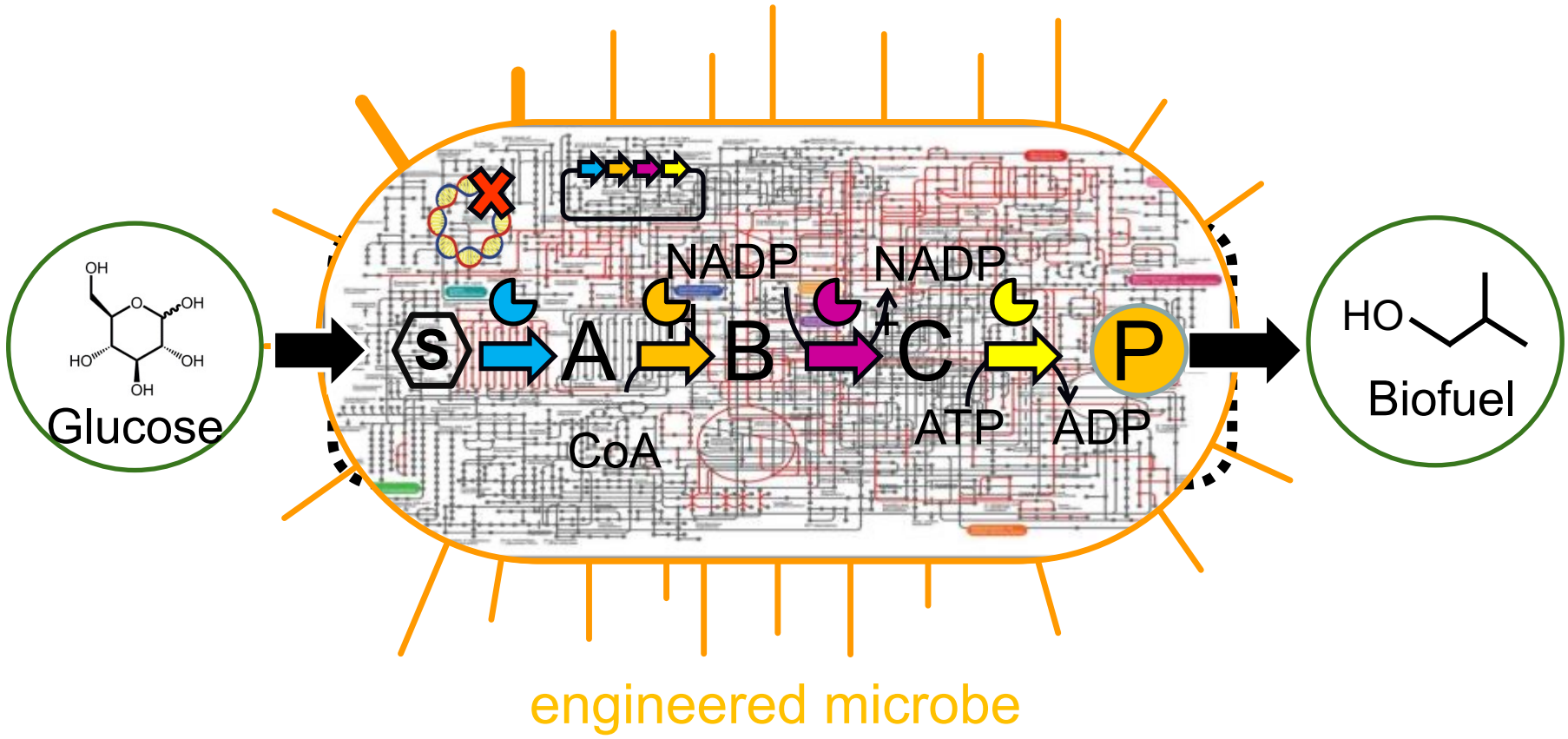

2 – Approach

Invizyne's Approach: Simplify Biocatalysis

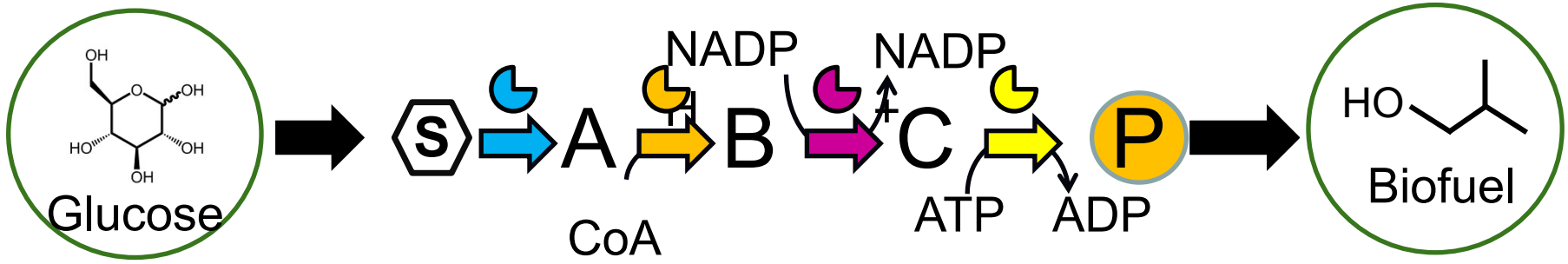

The Solution:
Get rid of the cells.

2 – Approach

Invizyne's *in vitro* strategy

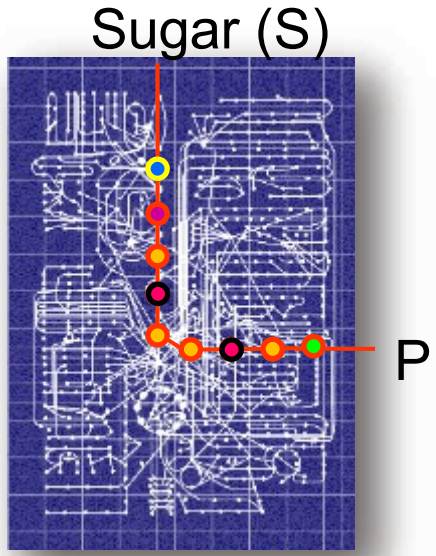

Don't need to worry about background metabolism

Only add elements necessary for biotransformation and regulation

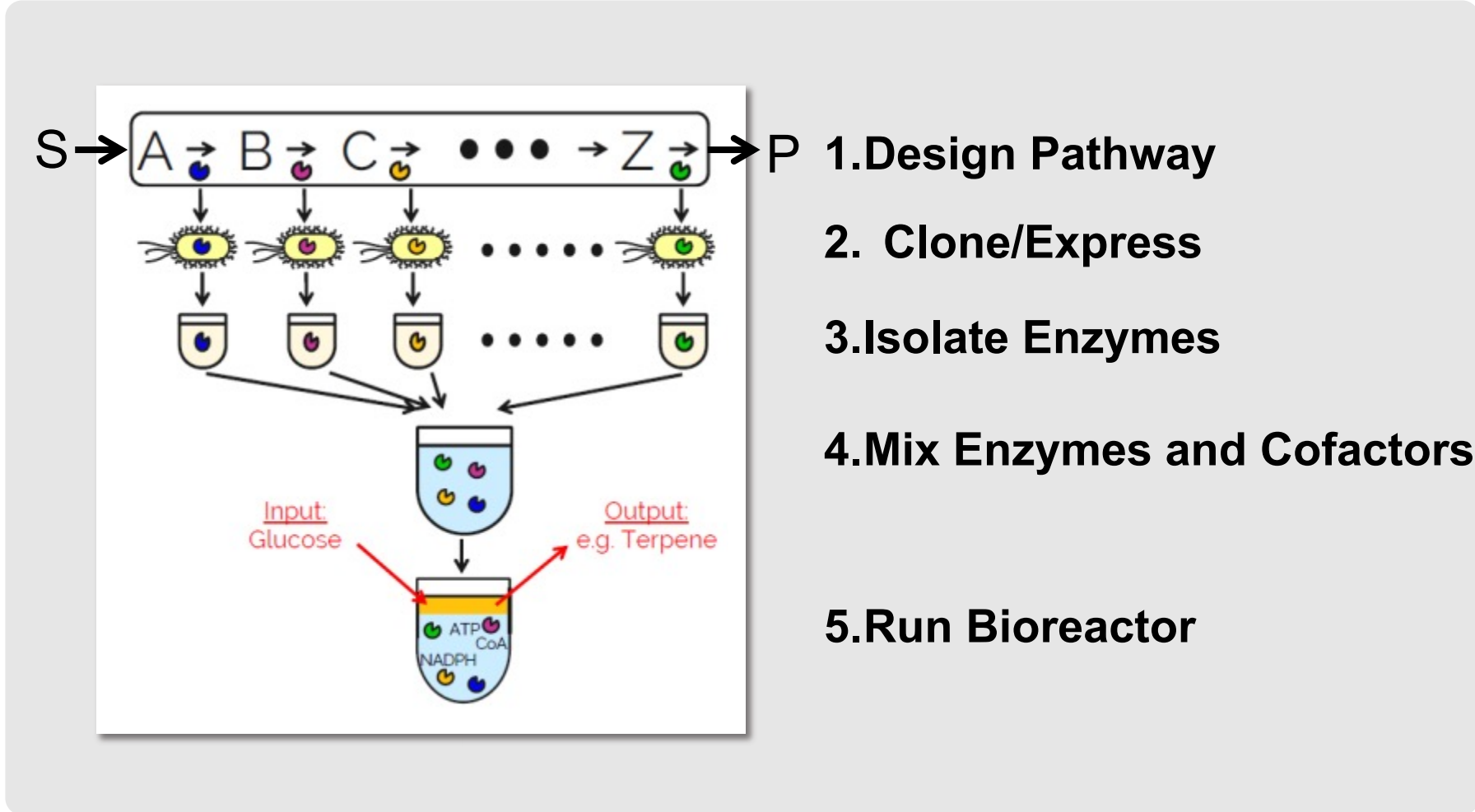

- 1. Design Pathway
- 2. Clone/Express
- 3. Isolate Enzymes
- 4. Mix Enzymes and Cofactors
- 5. Run Bioreactor

2 – Approach

Synthetic Biochemistry

Main Advantages

- High yields
- Easy optimization/Total Control
- Rapid Design-Build-Test Cycles
- Great flexibility in pathway design
- No toxicity headaches
- Easier product purification
- Potential for much higher productivity

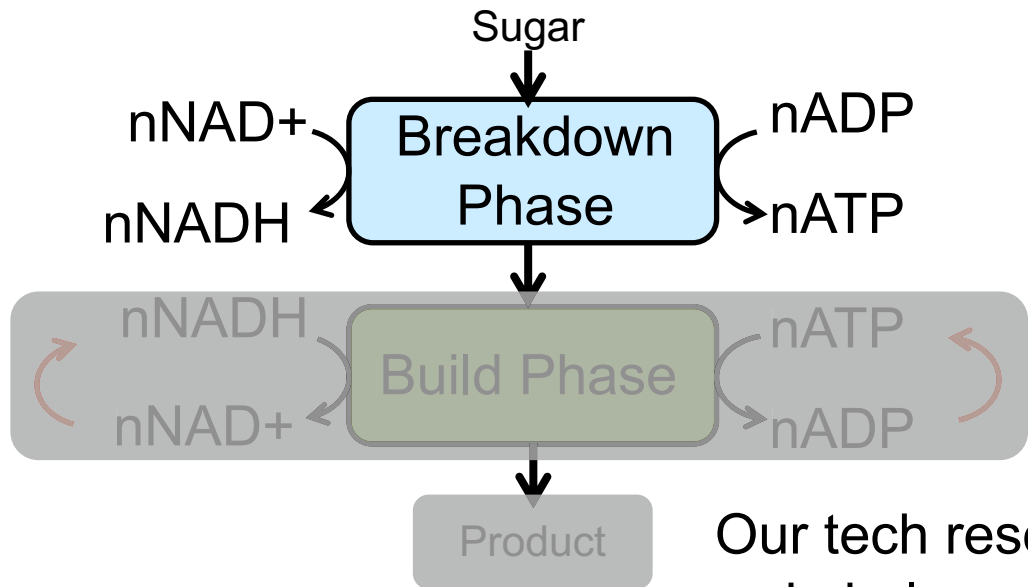

Our tech resolves imbalances!

Main Challenges

- Enzyme Cost
- Enzyme Stability
- **Cofactor Recycling and Maintenance**

Project Specific

- Ease of Scaling
 - Is it linear like a chemical reaction?
- Cellulosic Sugar Effects
 - Are compound present inhibitory to enzymes?
- Cofactor Use and Cost
 - Can cheaper cofactors be used?

Effect of Cofactor Choice on Isobutanol Cost			
TEA assumption: 300,000 L @ 4g/L/hr for 4 days with 10 g/L enzyme			
Cofactor	\$/kg	Isobutanol (\$/kg)	% of total cost
NADP	\$9000	\$22	85%
NAD	\$200	\$3.57	13%

2 – Approach

Isobutanol from Cellulosic Hydrolysate

Approach 1: Pure Glucose

- Optimize rates and loads
- Demonstrate high productivity
- Demonstrate high titer
- Use lessons learned with pure glucose to enable high titer production with cellulosic

Approach 2: Cellulosic

- Optimize conversion
- Increase titer
- Increase productivity
- Determine factors that contribute to differences compared to pure glucose

Go/No Go Criteria 1: Confirm past result (pure glucose) and demonstrate cellulosic hydrolysate can be used as a substrate

- Establish basis for measurement of progress

Go/No Go Criteria 2: Reach meaningful metrics for isobutanol production using cellulosic hydrolysate with a scaled system

- Establishes validity of process and demonstrates impact

Technical metrics measured by productivity (g/L/hr and titer (g/L)

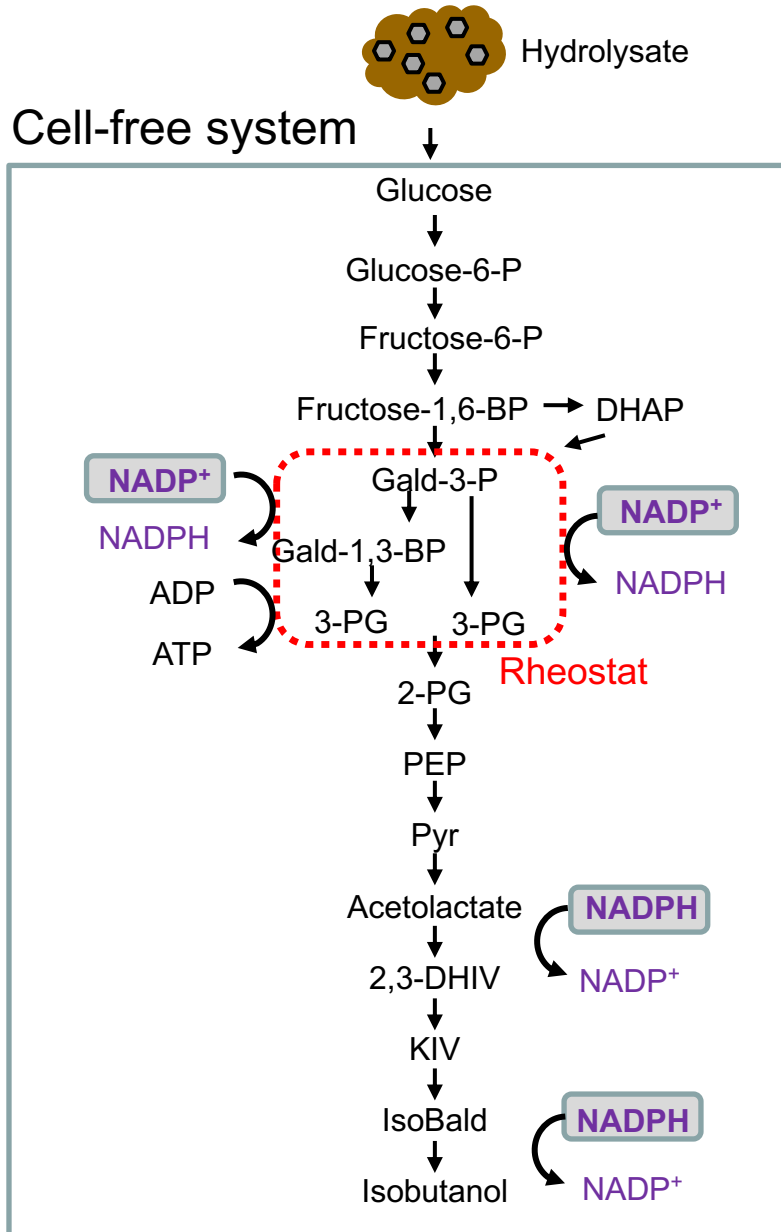

3 – Impact

Increasing Simplicity and Flexibility

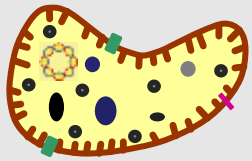

Cell-based (*in vivo*)

Standard in the field
Often costly and difficult
Limited substrate/product

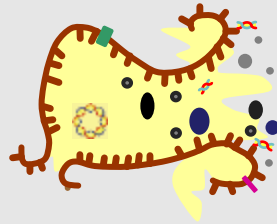

Cell-lysate

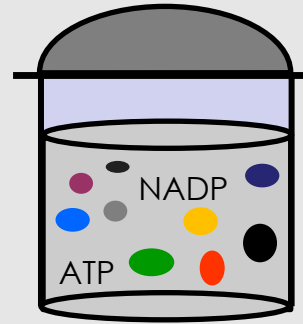

Cell-free (*in vitro*)

Flexible
Direct Prototype to Product
Toxic Product OK
Simple Purification
Expanded Chemical Space

Demonstrated High Impact

- Publication in high impact journals
 - Nature Communications
 - Nature Chemical Biology
- Interest from large industrial producers of chemicals
 - Talks ongoing

Potential for **high impact** by allowing bioconversions to perform more like chemical reactions and lower cost of production

4 – Progress and Outcomes: Cell-free Isobutanol Production

Task Breakdown

Invizyne

Cellulosic Hydrolysate Tasks (2,9,12,13)
Enzyme Rate/Cofactor Utilization Tasks (4,6)
Protein Production Tasks (7,10)

UCLA

Pure Glucose Tasks (1,8,11)
Enzyme Rate/Stability Tasks (3,4,5)
Protein Production Tasks (7,10)

FY19-20	Task	Description	Planned	Actual
Go/No-Go 1	1	Repeat Pure Glucose to Isobutanol Result	100%	100%
Go/No-Go 1	2	Confirm Hydrolysate to Isobutanol	100%	100%
	3	Optimize Enzyme/Cofactor Load	100%	100%
	4	Improve Rate of Slowest Enzymes	30%	60%
	5	Analyze Presence and Type of Inhibition	100%	90%
	6	Cofactor Swap	80%	80%
	7	Enzyme Production for Scale	100%	75%
Go/No-Go 2	8	Scaled Pure Glucose to Isobutanol System	30%	30%
Go/No-Go 2	9	Improved and Scaled Cellulosic Isobutanol System	30%	50%

All Tasks on Track to Reach or Exceed Important Milestones on Schedule

4 – Progress and Outcomes: Cell-free Isobutanol Production

- **Task 2/5: Analyze hydrolysate and intermediates for inhibition of specific enzymes**
 - Inhibitory characteristics of hydrolysate and intermediates determined and solutions provided
- **Task 3: Optimize current system to establish minimum enzyme and cofactor load**
 - Minimum values determined for enzyme and cofactors to maintain baseline productivity
- **Task 4: Improve rate of specific enzymes**
 - More active variants found and implemented for multiple steps in the pathway
 - Work is ongoing to engineer faster variants for remaining slow steps
- **Task 6: Re-engineer cofactor preference**
 - Successfully swapped cofactor preference for multiple steps
- **Task 7: Produce sufficient enzyme for scaling efforts**
 - Enough enzyme produced on-hand to complete Tasks 8 and 9 and reach Go/No-Go
- **Task 8: Scale pure glucose to isobutanol system**
 - Work ongoing
- **Task 9: Scaled system for cellulosic glucose to isobutanol**
 - Exceeded production metrics. Scaling work ongoing

All Tasks on Schedule to Reach or Exceed Important Milestones

4 – Progress and Outcomes: Cell-free Isobutanol Production

Task 1

Even 25% titer increase would be significant due to high baseline

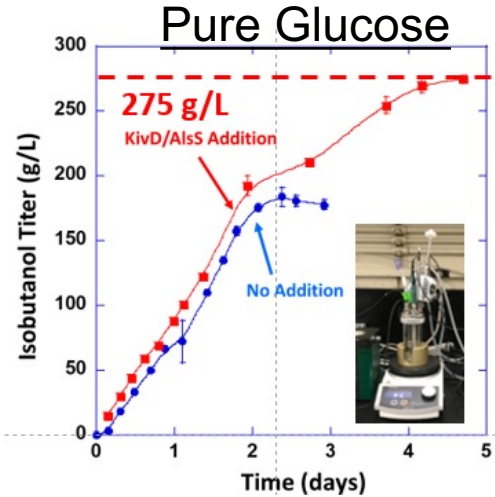

Task 2

From Demonstration $\xrightarrow{\text{to}}$ Optimization and Production

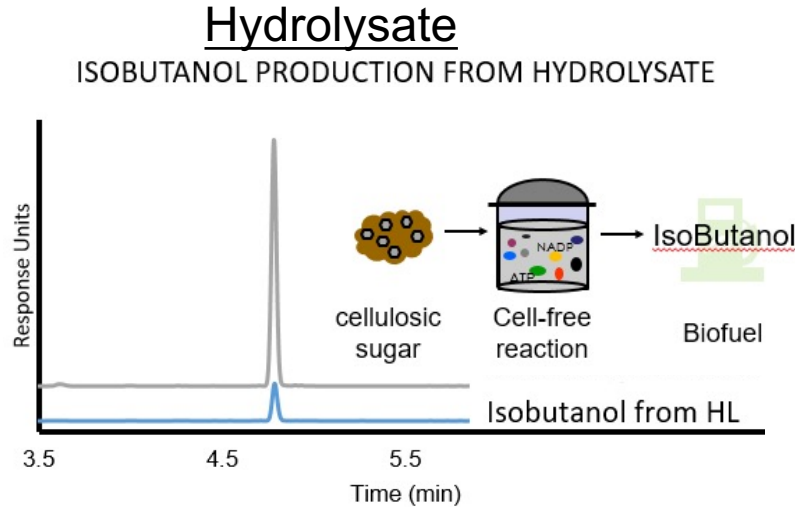

Task 9

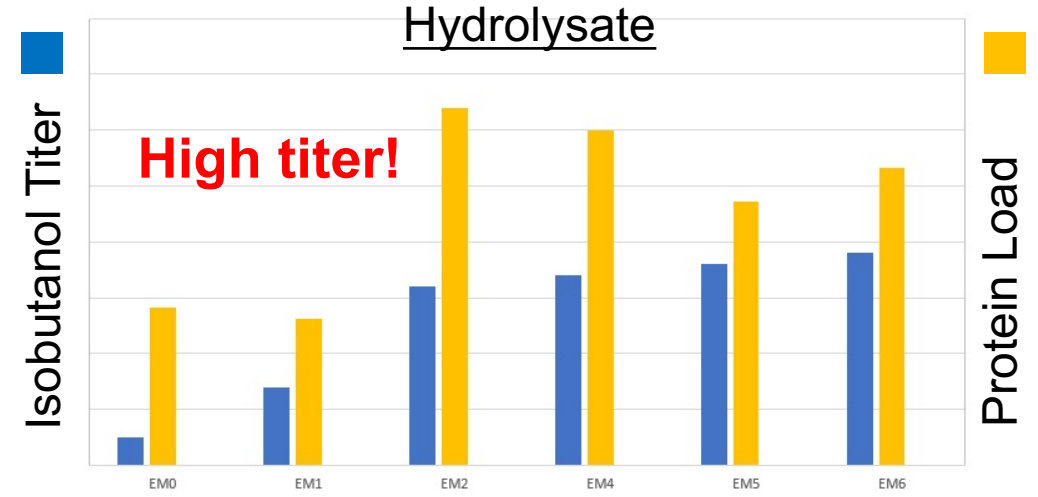

Optimization Experiment

- ✓ Hydrolysate to isobutanol optimized
- ✓ Cofactor and protein loads optimized
- ✓ Cofactor preference of 3 of 4 enzymes
- Reaction scaling and enzyme engineering in progress and on track

Task 3

Cofactor Load Optimization

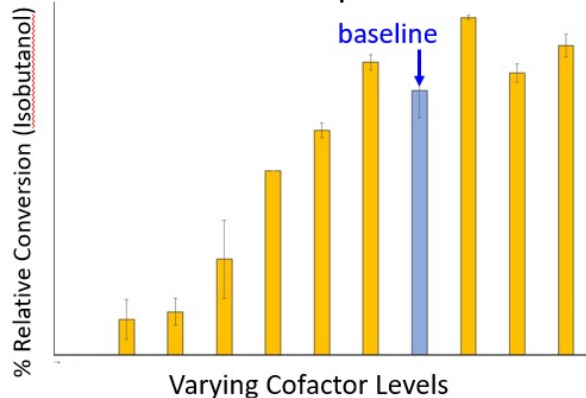

Task 6

Cofactor Swap

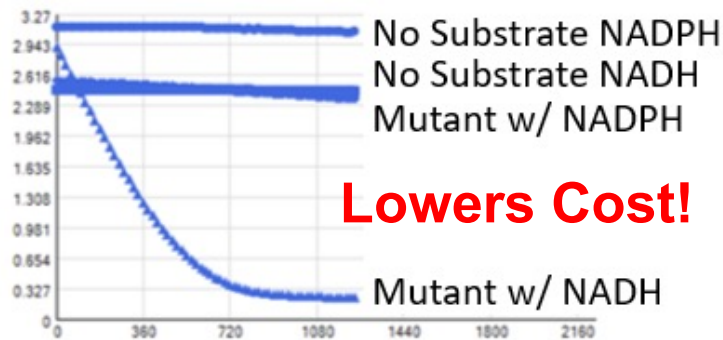

Summary

- *Multi-step enzymatic cell-free bio-transformations are real alternatives to microbial conversions*
- *Glucose from a cellulosic hydrolysate can be used almost as efficiently as pure glucose without toxicity problems*
- *Enzyme engineering can be used efficiently to lower costs by enabling the use of cheaper cofactors and lower protein loads*
- *By the end of the Project we will have a cell-free system that outperforms any previous microbial system for the conversion of a biofuel from cellulosic feedstock*

Quad Chart Overview (Competitive Project)

Timeline

- 10/01/2019
- 09/30/22

	FY20 Costed	Total Award
DOE Funding	(10/01/2019 – 9/30/2020) \$302,278	\$2,078,605
Project Cost Share	\$91,756	\$563,204

Project Partners*

- UCLA (Dr. James U. Bowie)

Project Goal

The goal of this project is to develop a novel route to advanced biofuels from cellulosic sugars by developing cell-free enzymatic routes that are efficient, have high carbohydrate utilization, and have the potential to be cost effective processes.

End of Project Milestones

12b. System that produces isobutanol from pure glucose at 10 g/L/h initial productivity reaching a titer of 500 g/L by 5 days at >90% yield at a 150 mL scale.

13b. System that produces isobutanol from glucose-rich cellulosic hydrolysate at 2 g/L/h initial productivity reaching a titer of 40 g/L by 5 days at >90% yield at a 150 mL scale.

Funding Mechanism

DE-FOA-0002029, AOI 7a: Advanced Bioprocessing, 2019

*Only fill out if applicable.

Additional Slides

Publications, Patents, Presentations, Awards, and Commercialization

- List any publications, patents, awards, and presentations that have resulted from work on this project
- Use at least 12 point font
- Describe the status of any technology transfer or commercialization efforts

Note: This slide is for the use of the Peer Reviewers only – it is not to be presented as part of your oral presentation. These Additional Slides will be included in the copy of your presentation that will be made available to the Reviewers.