



Orano Federal Services
Title: Design and Prototype Fabrication of Railcars for Transport of
High-Level Radioactive Material Phase 3 – Prototype Fabrication and Delivery
Appendix A

Doc./Rev.: EIR-3021970-000
Project: 00225.03.0050 DOE Atlas Project

Appendix A

Atlas Railcar As-Built Fabrication Drawings

APPENDIX A.1 GENERAL ARRANGEMENT

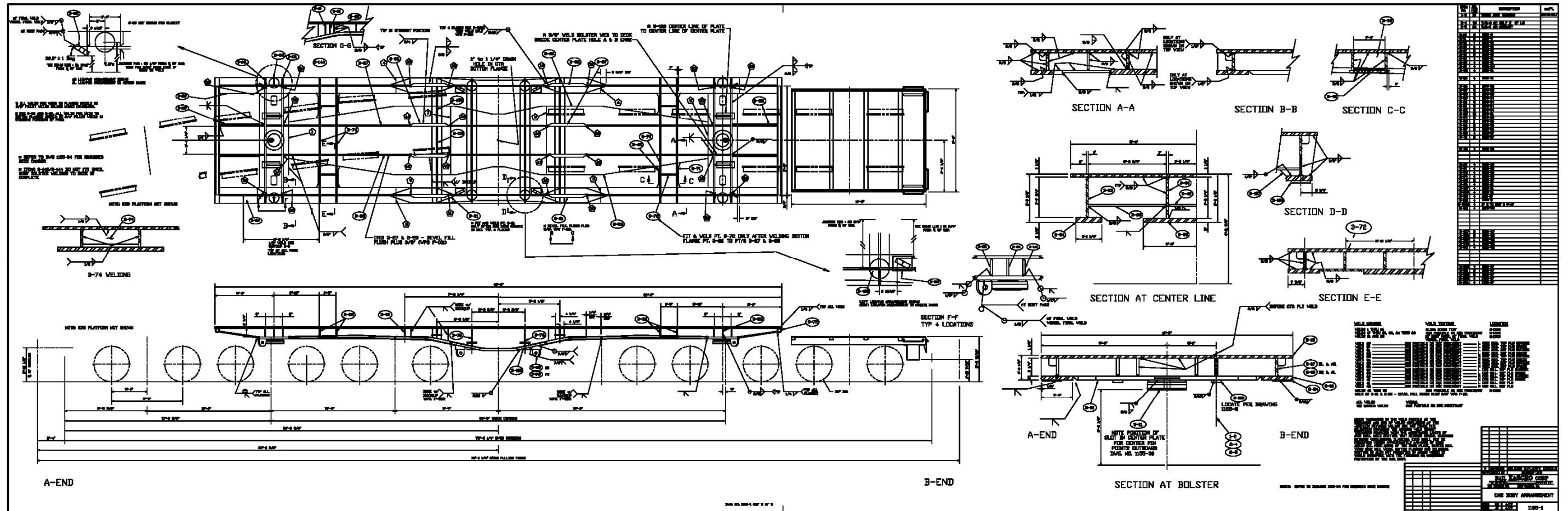

APPENDIX A.3 STENCIL ARRANGEMENT

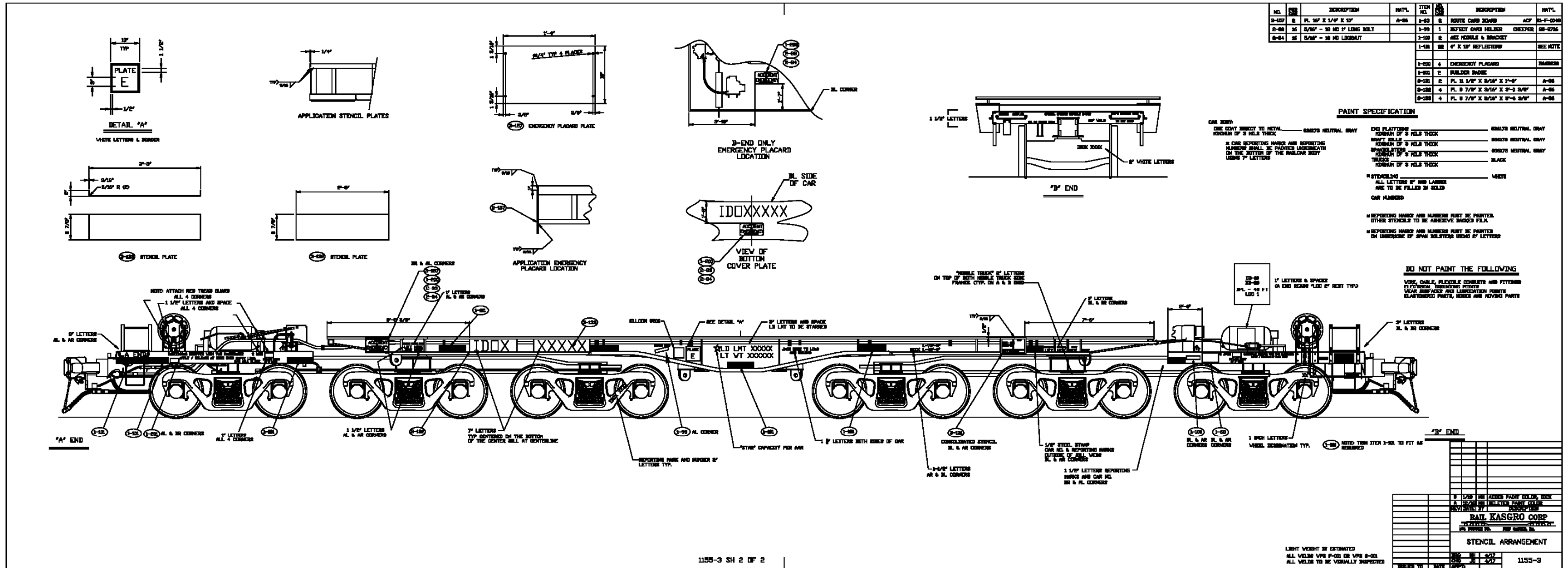

APPENDIX A.4 END PLATFORM ARRANGEMENT

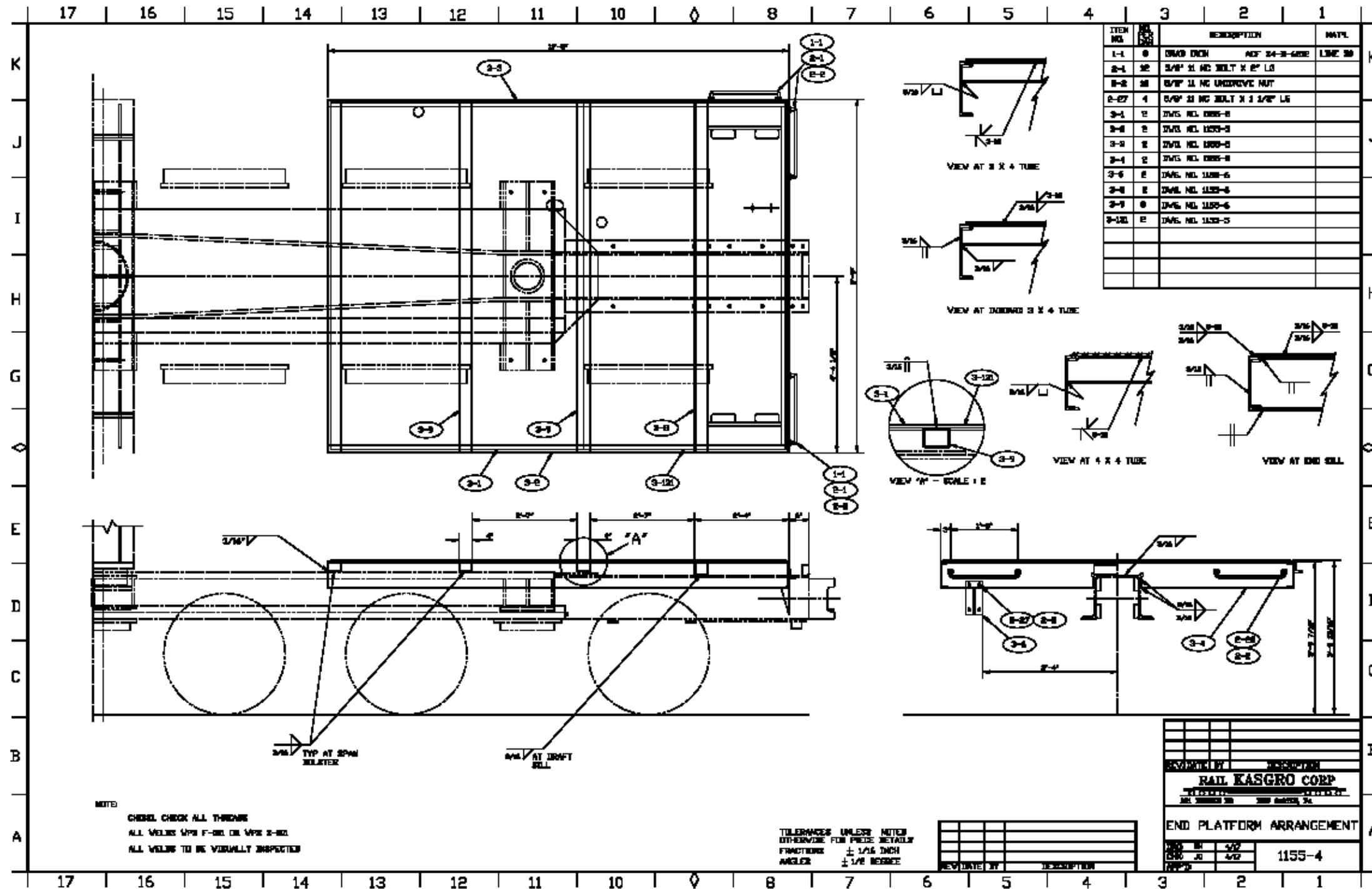

APPENDIX A.5 END PLATFORM DETAILS

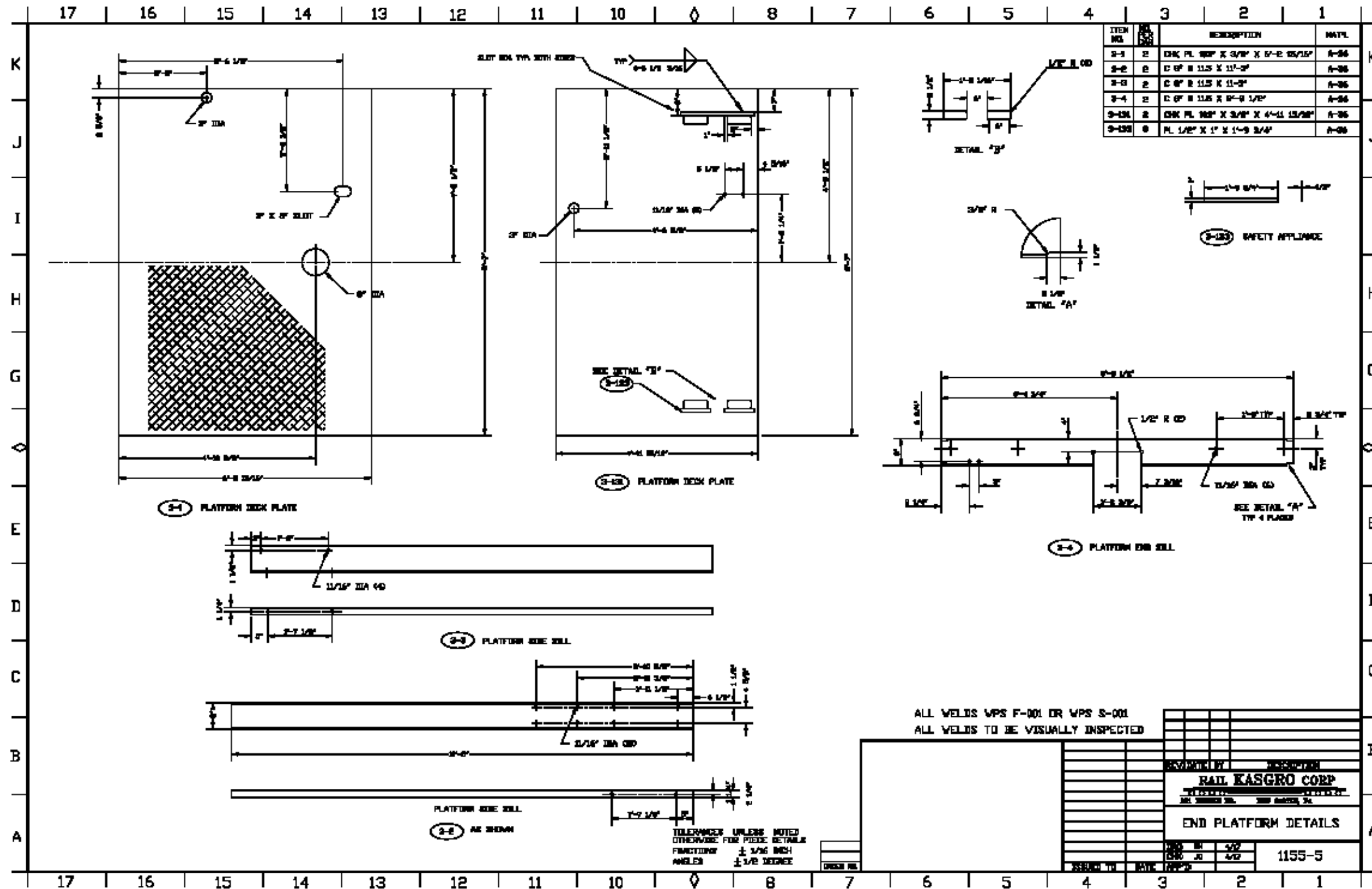

APPENDIX A.6 END PLATFORM DETAILS

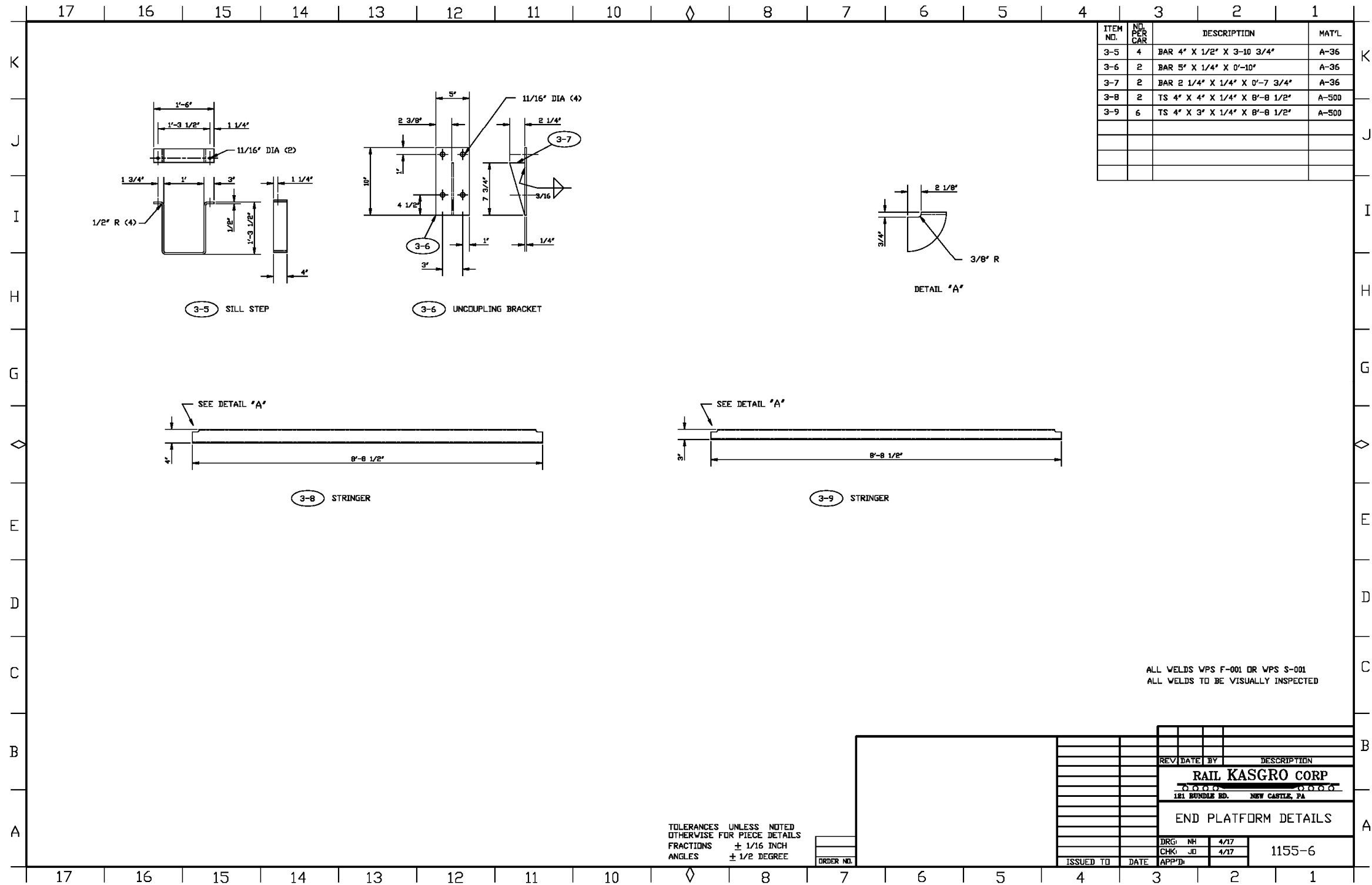



Orano Federal Services
 Title: Design and Prototype Fabrication of Railcars for Transport of
 High-Level Radioactive Material Phase 3 – Prototype Fabrication and Delivery
 Appendix A

Doc./Rev.: EIR-3021970-000
 Project: 00225.03.0050 DOE Atlas Project

APPENDIX A.7 AIR BRAKE SCHEMATIC

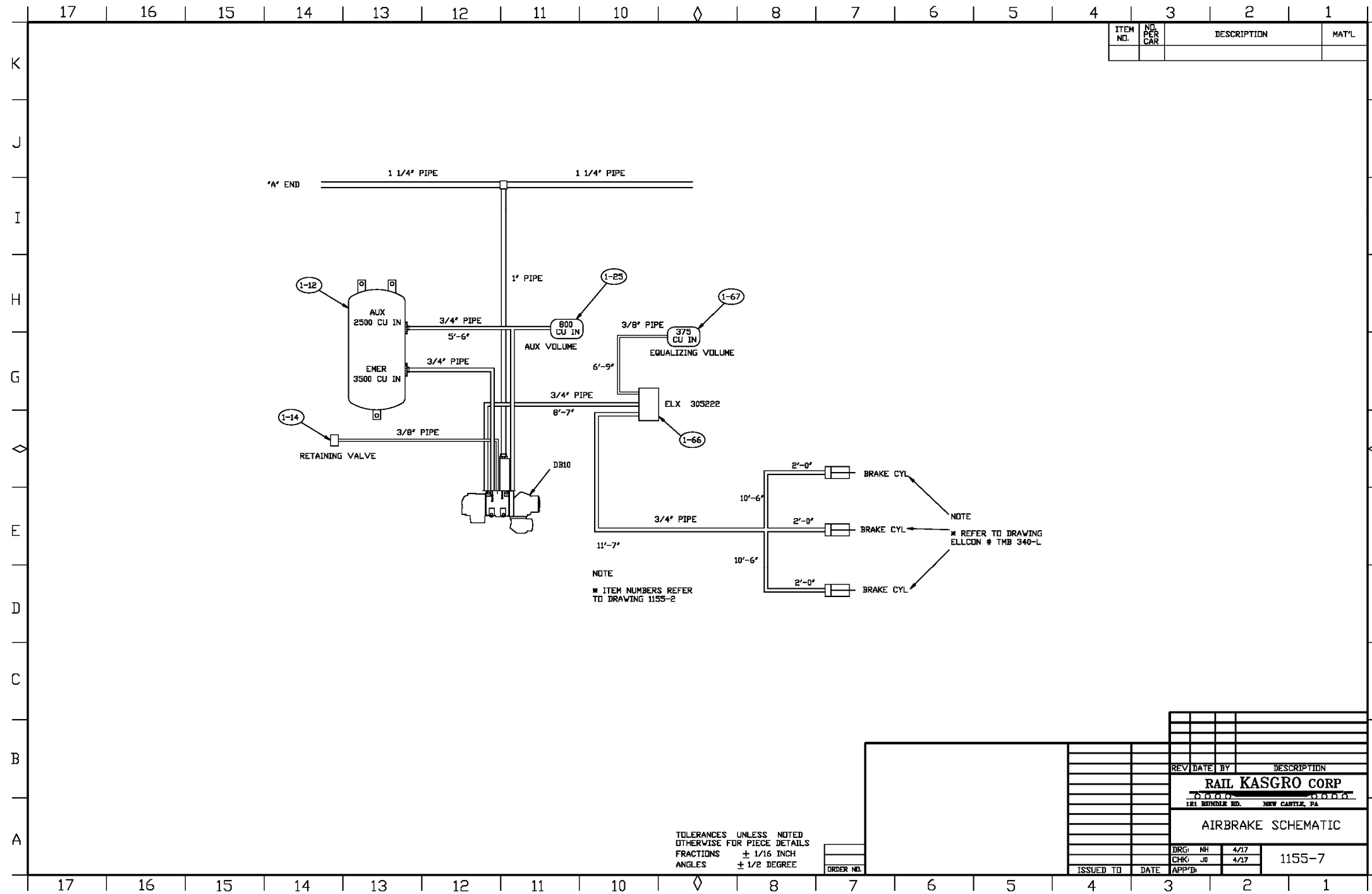

APPENDIX A.8 BODY BOLSTER

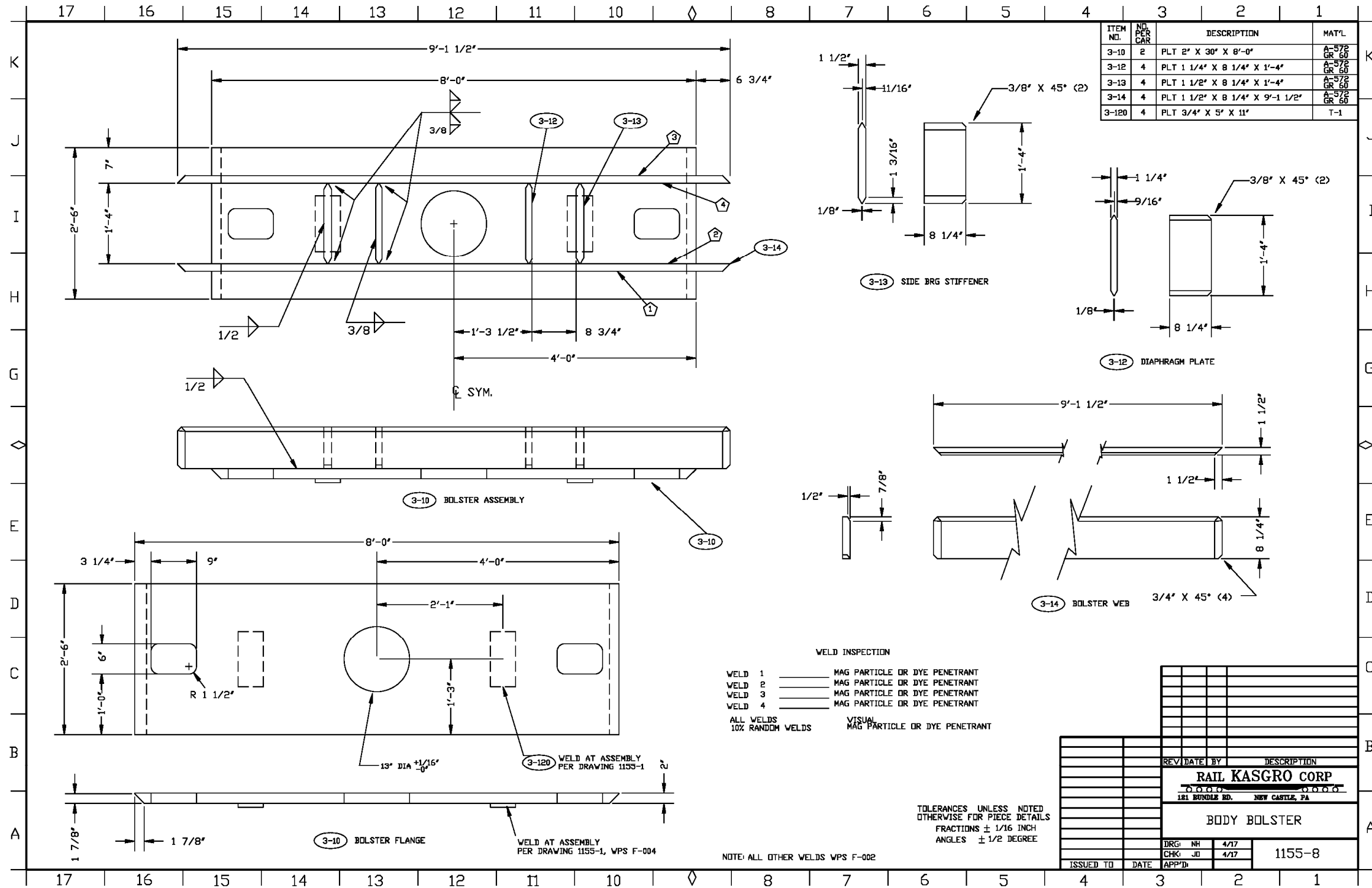

APPENDIX A.11 STEEL DETAILS

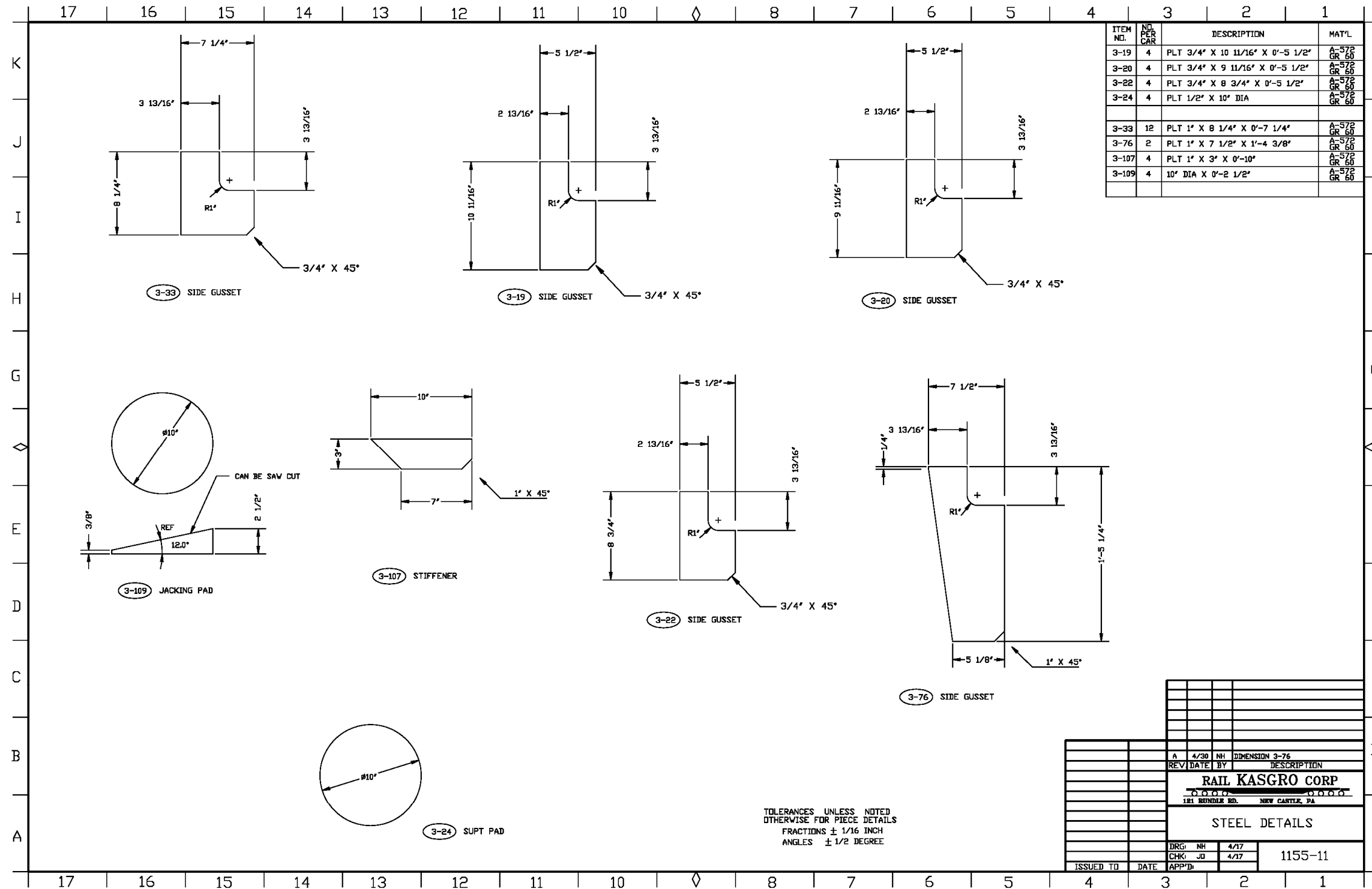

ITEM NO.	NO. PER CAR	DESCRIPTION	MAT'L
3-19	4	PLT 3/4" X 10 11/16" X 0'-5 1/2"	A-572 GR 60
3-20	4	PLT 3/4" X 9 11/16" X 0'-5 1/2"	A-572 GR 60
3-22	4	PLT 3/4" X 8 3/4" X 0'-5 1/2"	A-572 GR 60
3-24	4	PLT 1/2" X 10" DIA	A-572 GR 60
3-33	12	PLT 1" X 8 1/4" X 0'-7 1/4"	A-572 GR 60
3-76	2	PLT 1" X 7 1/2" X 1'-4 3/8"	A-572 GR 60
3-107	4	PLT 1" X 3" X 0'-10"	A-572 GR 60
3-109	4	10" DIA X 0'-2 1/2"	A-572 GR 60

REV	DATE	BY	DESCRIPTION
A	4/30	NH	DIMENSION 3-76

RAIL KASGRO CORP
 181 BUNDLER RD., NEW CASTLE, PA

STEEL DETAILS

DRG:	NH	4/17	1155-11
CHK:	JJ	4/17	
ISSUED TO:	DATE:	APP'D:	



Orano Federal Services
Title: Design and Prototype Fabrication of Railcars for Transport of
High-Level Radioactive Material Phase 3 – Prototype Fabrication and Delivery
Appendix A

Doc./Rev.: EIR-3021970-000
 Project: 00225.03.0050 DOE Atlas Project

APPENDIX A.13 STEEL DETAILS

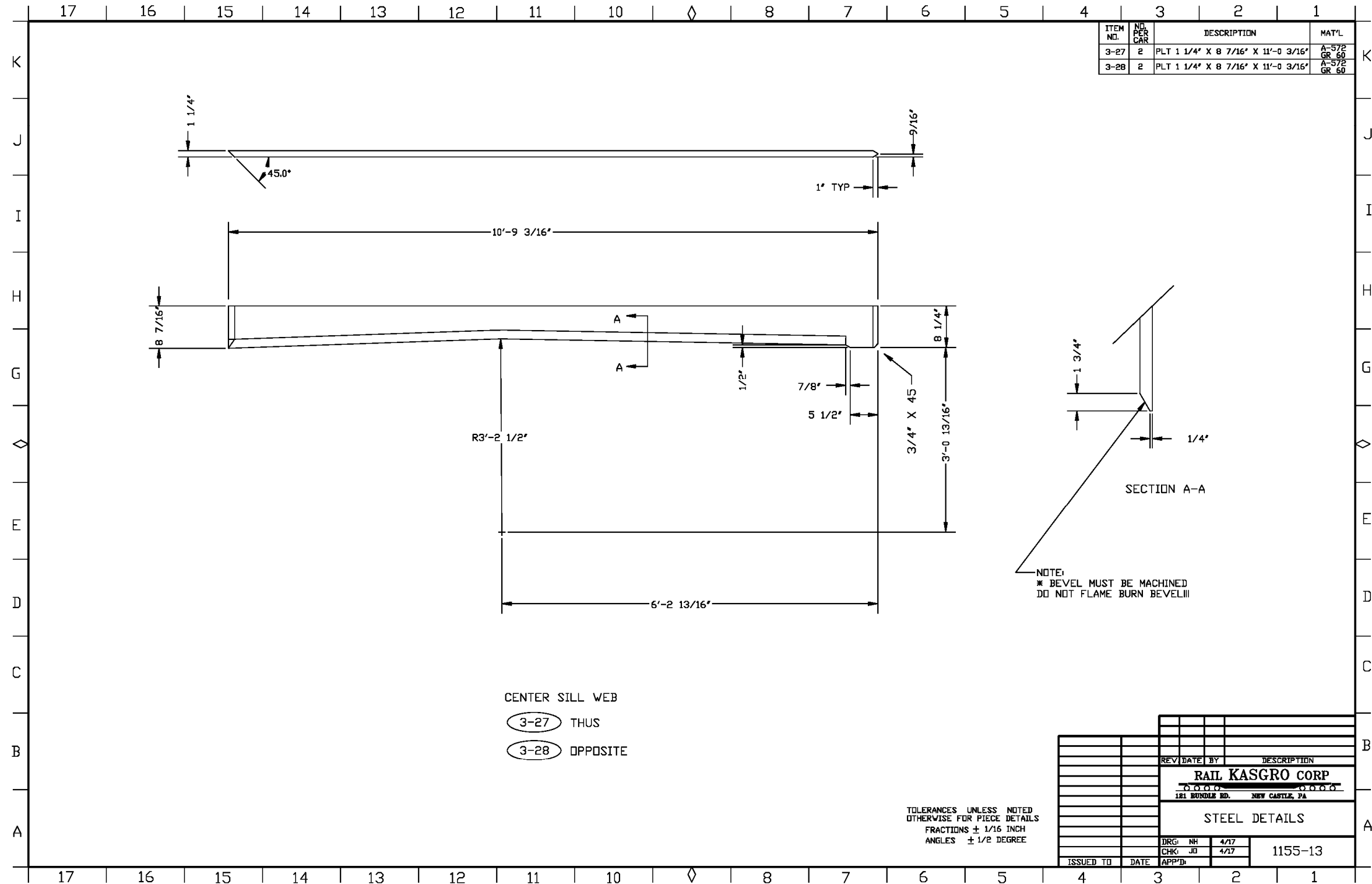



Orano Federal Services
Title: Design and Prototype Fabrication of Railcars for Transport of
High-Level Radioactive Material Phase 3 – Prototype Fabrication and Delivery
Appendix A

Doc./Rev.: EIR-3021970-000
 Project: 00225.03.0050 DOE Atlas Project

APPENDIX A.14 STEEL DETAILS

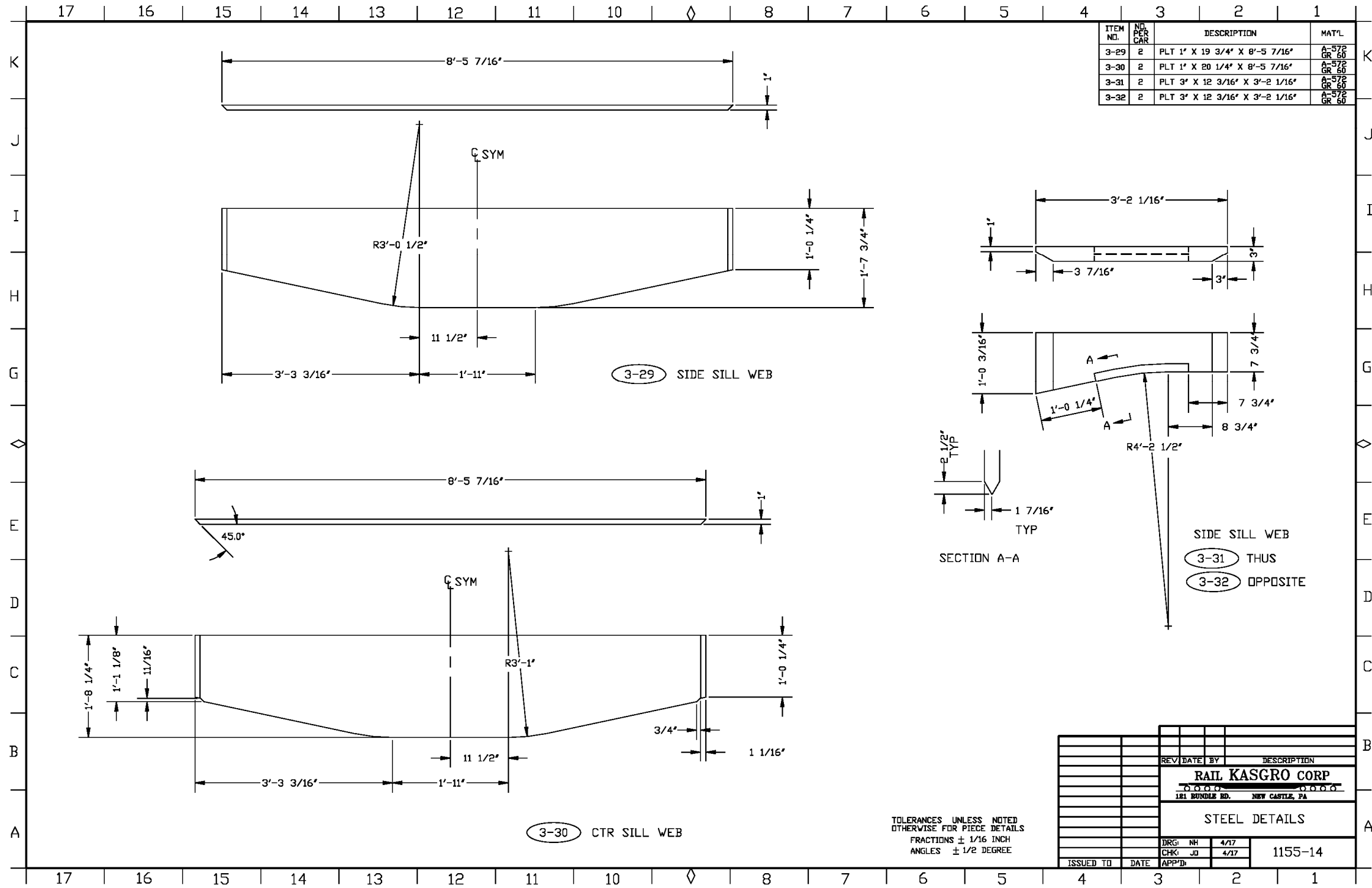



Orano Federal Services
Title: Design and Prototype Fabrication of Railcars for Transport of
High-Level Radioactive Material Phase 3 – Prototype Fabrication and Delivery
Appendix A

Doc./Rev.: EIR-3021970-000
 Project: 00225.03.0050 DOE Atlas Project

APPENDIX A.15 STEEL DETAILS

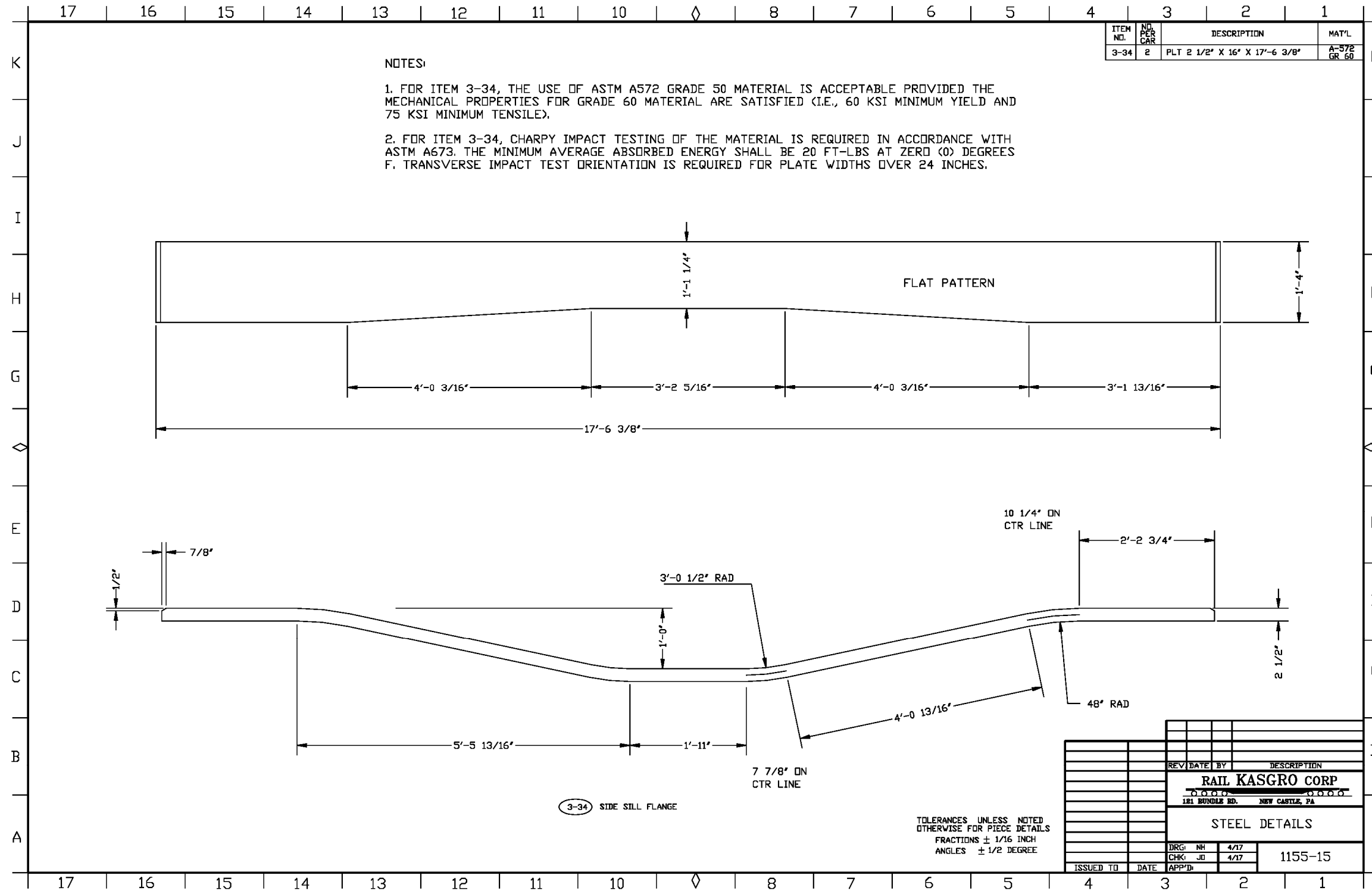

APPENDIX A.16 STEEL DETAILS

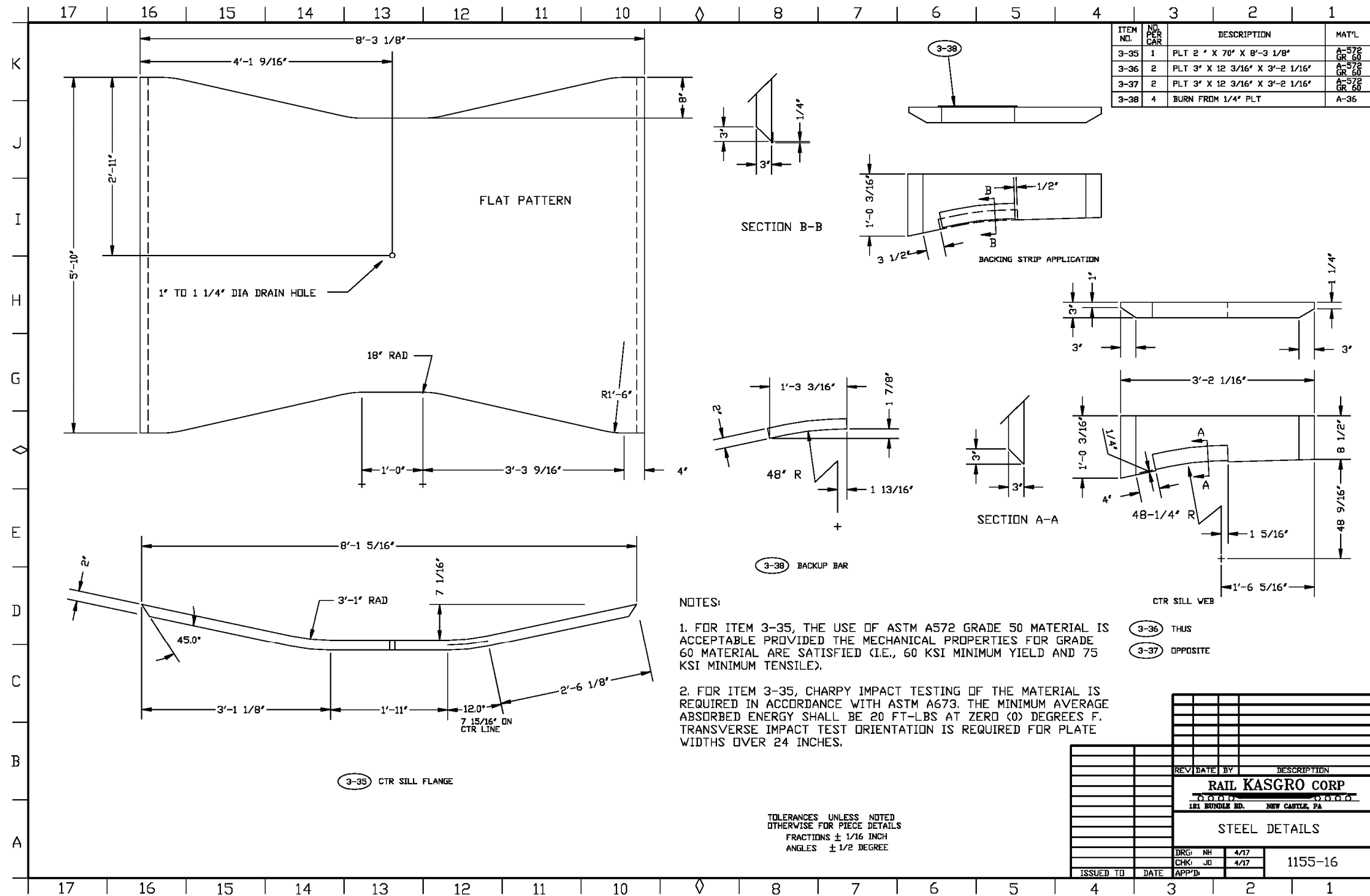

APPENDIX A.17 STEEL DETAILS

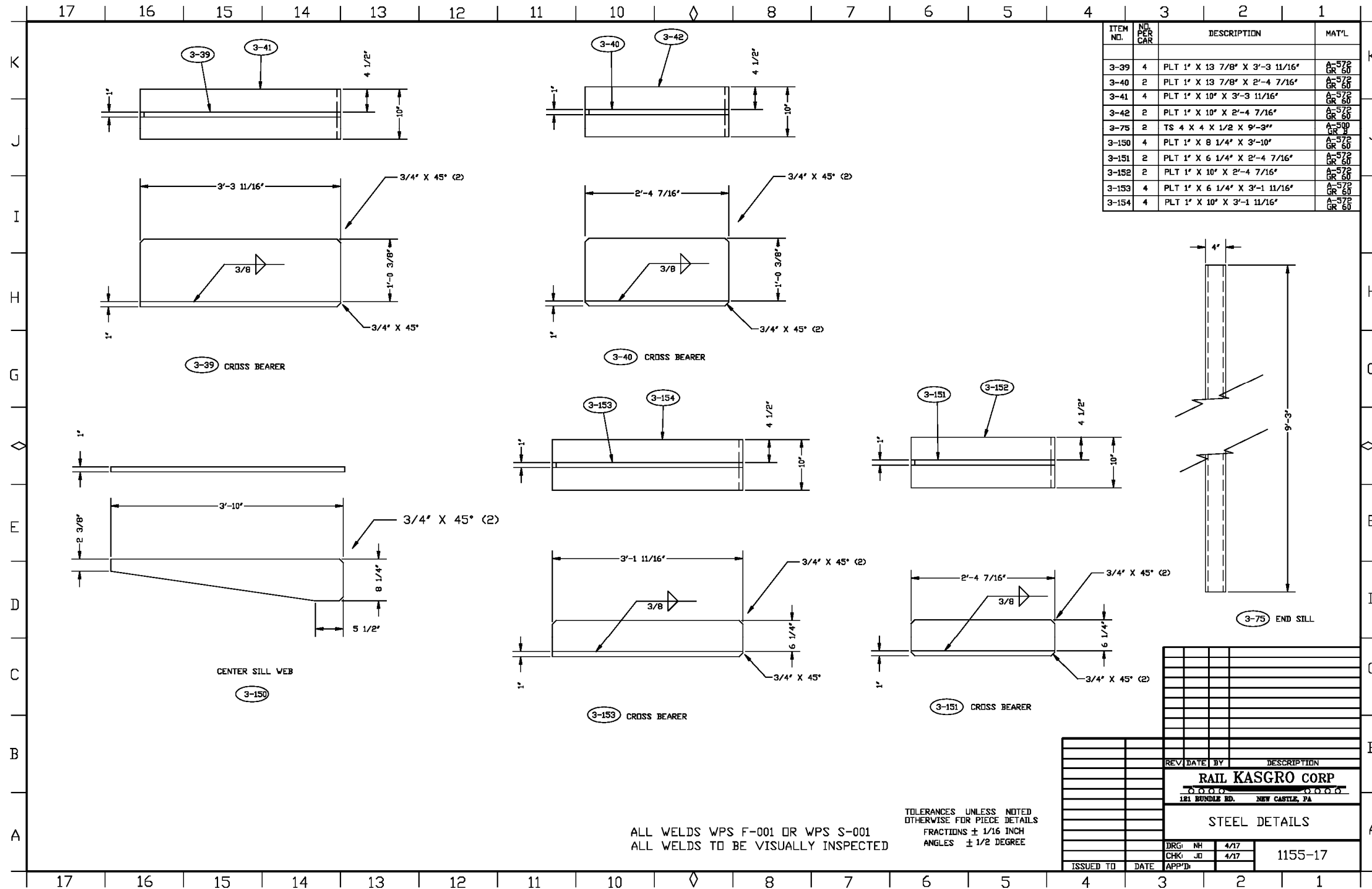

APPENDIX A.20 BRAKE STEEL DETAILS

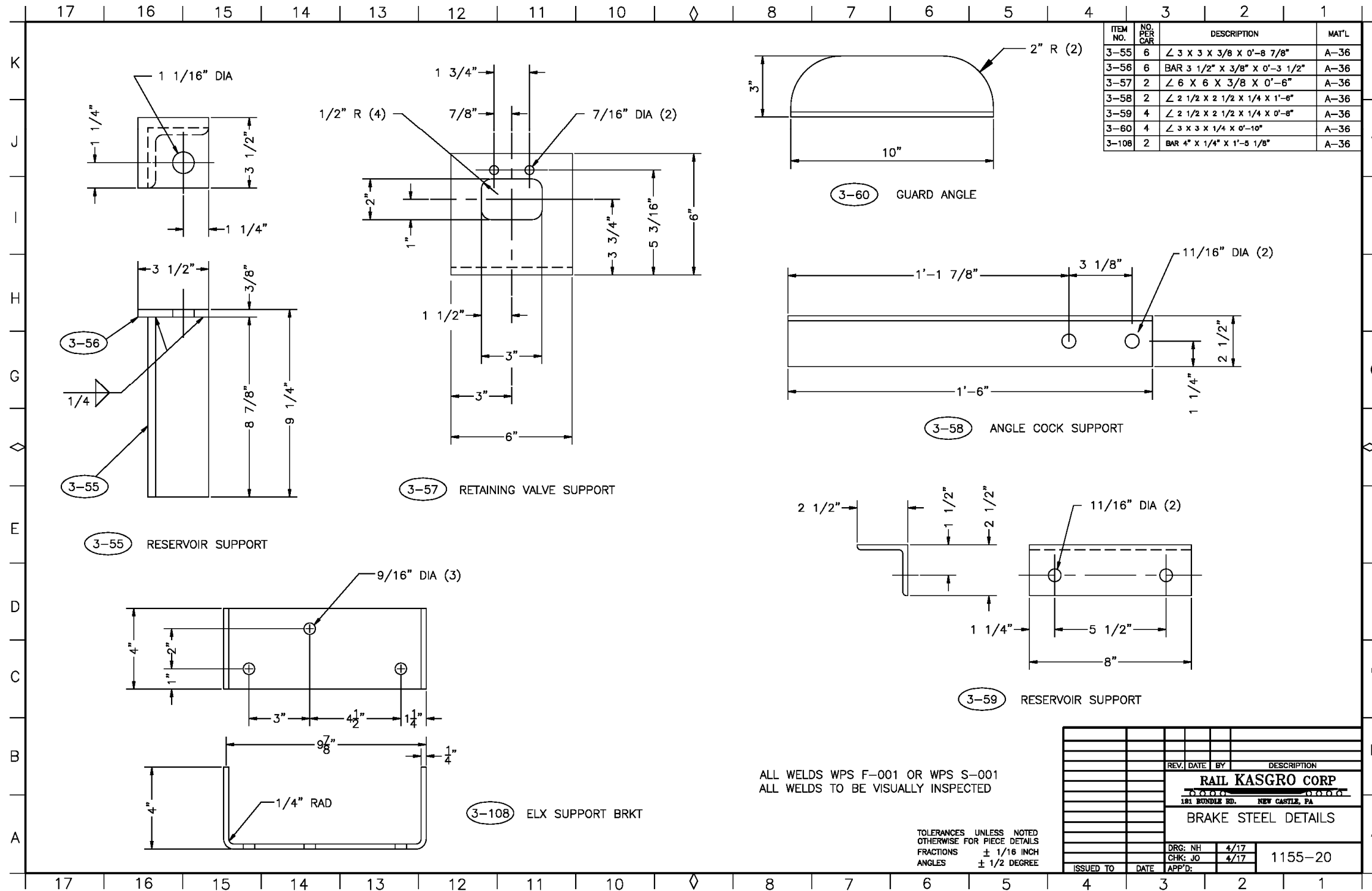



Orano Federal Services
Title: Design and Prototype Fabrication of Railcars for Transport of
High-Level Radioactive Material Phase 3 – Prototype Fabrication and Delivery
Appendix A

Doc./Rev.: EIR-3021970-000
 Project: 00225.03.0050 DOE Atlas Project

APPENDIX A.22 PIPE DETAILS

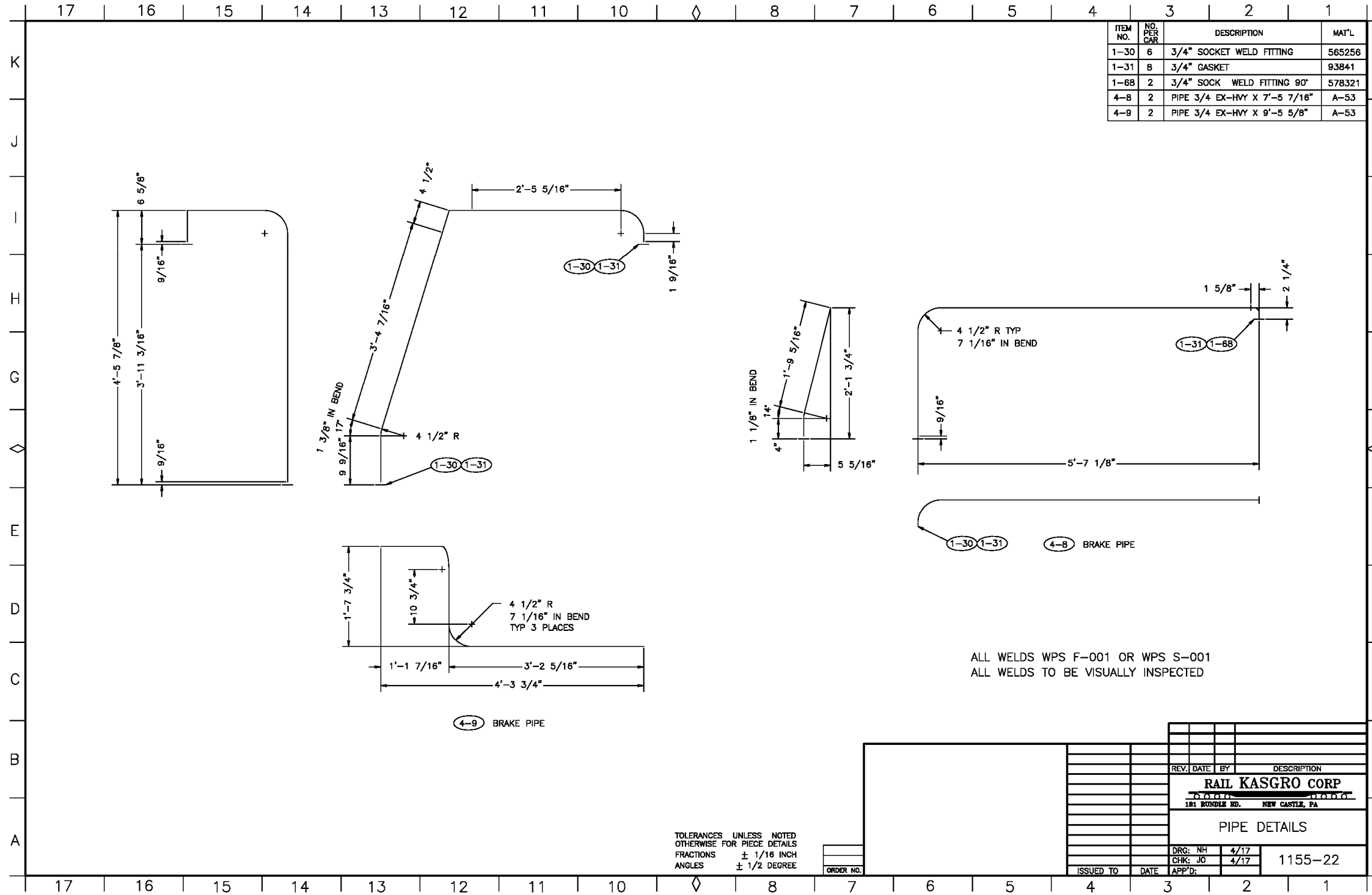



Orano Federal Services
Title: Design and Prototype Fabrication of Railcars for Transport of
High-Level Radioactive Material Phase 3 – Prototype Fabrication and Delivery
Appendix A

Doc./Rev.: EIR-3021970-000
 Project: 00225.03.0050 DOE Atlas Project

APPENDIX A.24 STEEL DETAILS

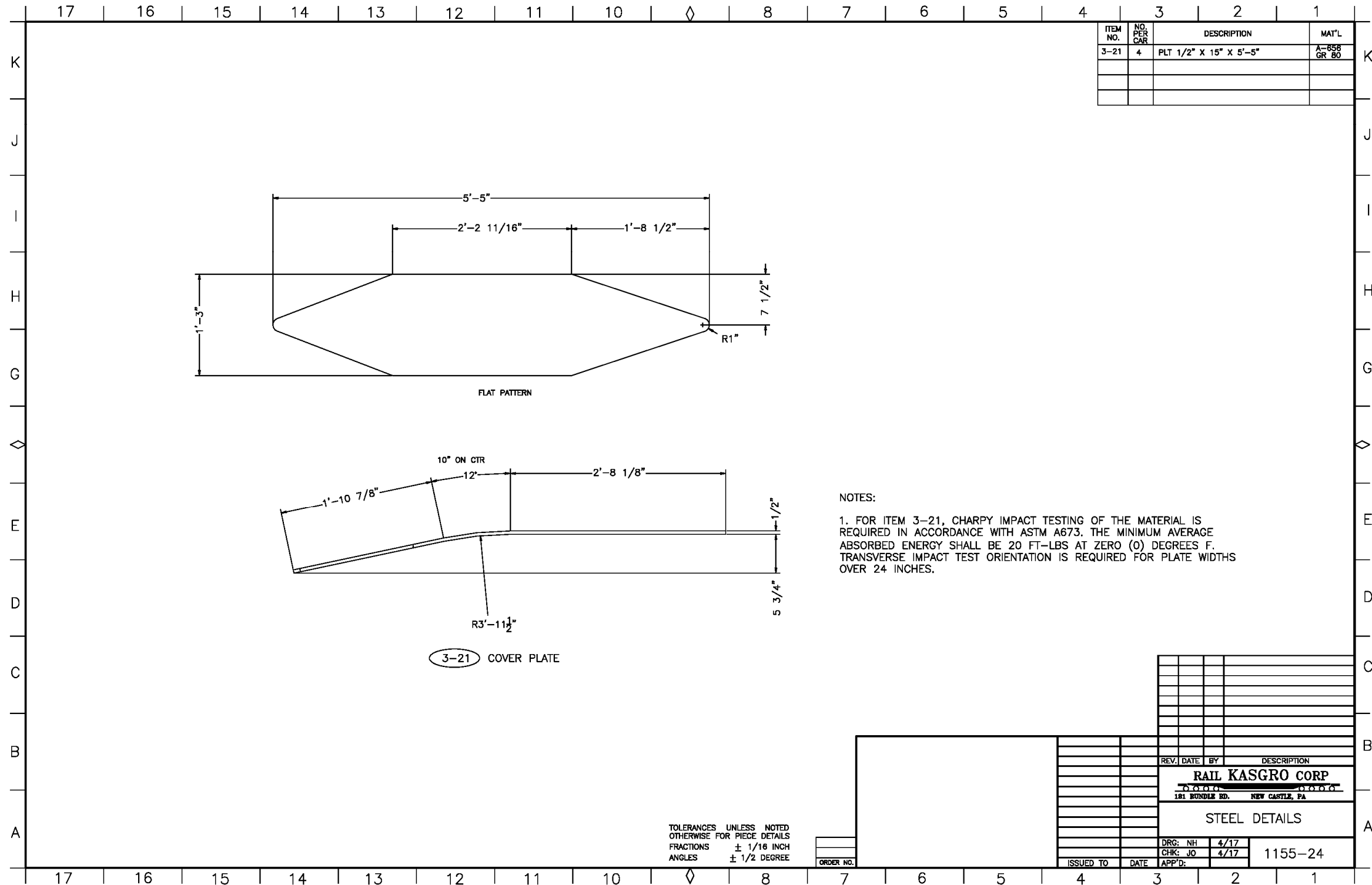

APPENDIX A.25 HAND BRAKE DETAILS

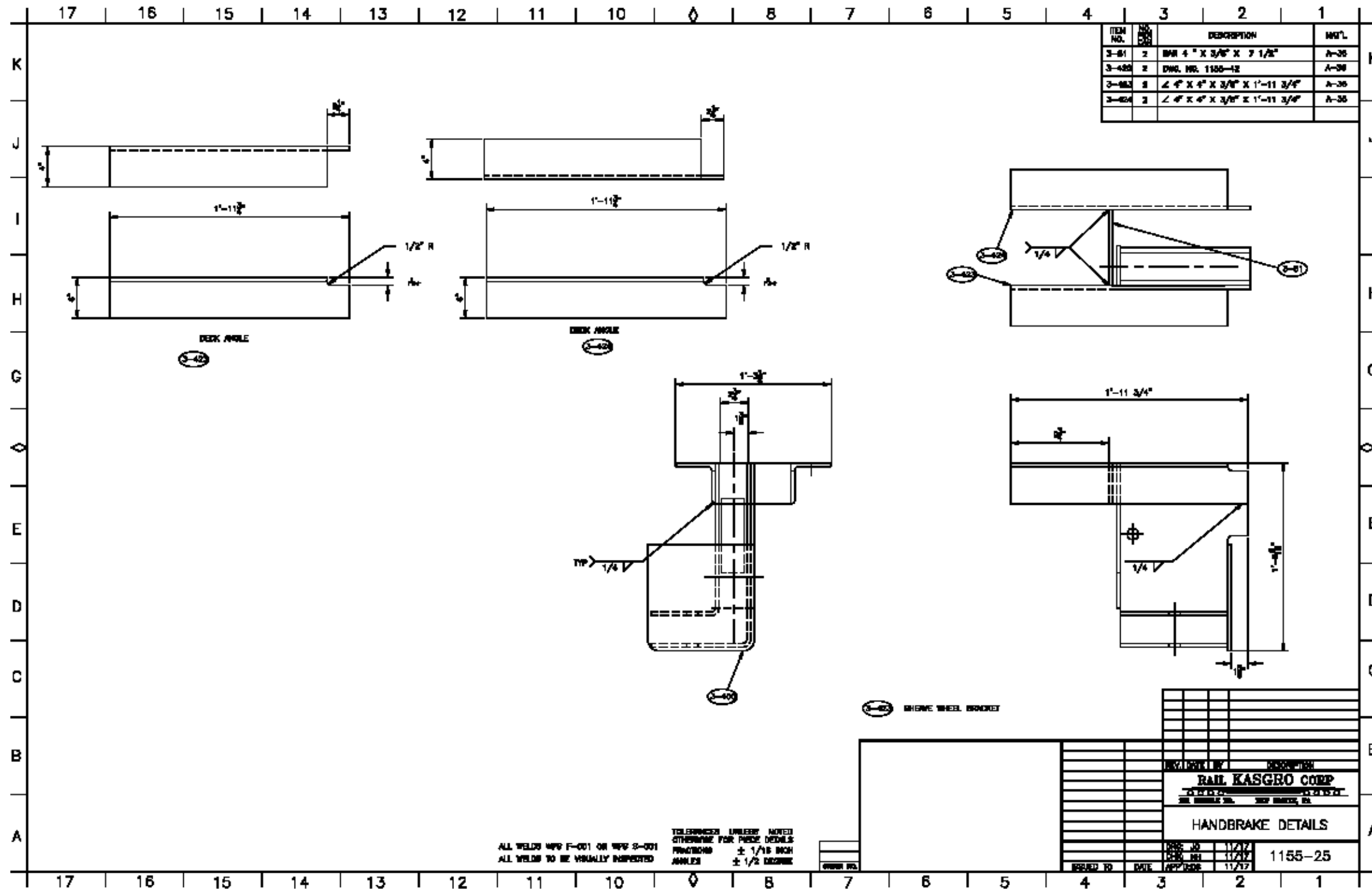

APPENDIX A.28 HAND BRAKE DETAILS

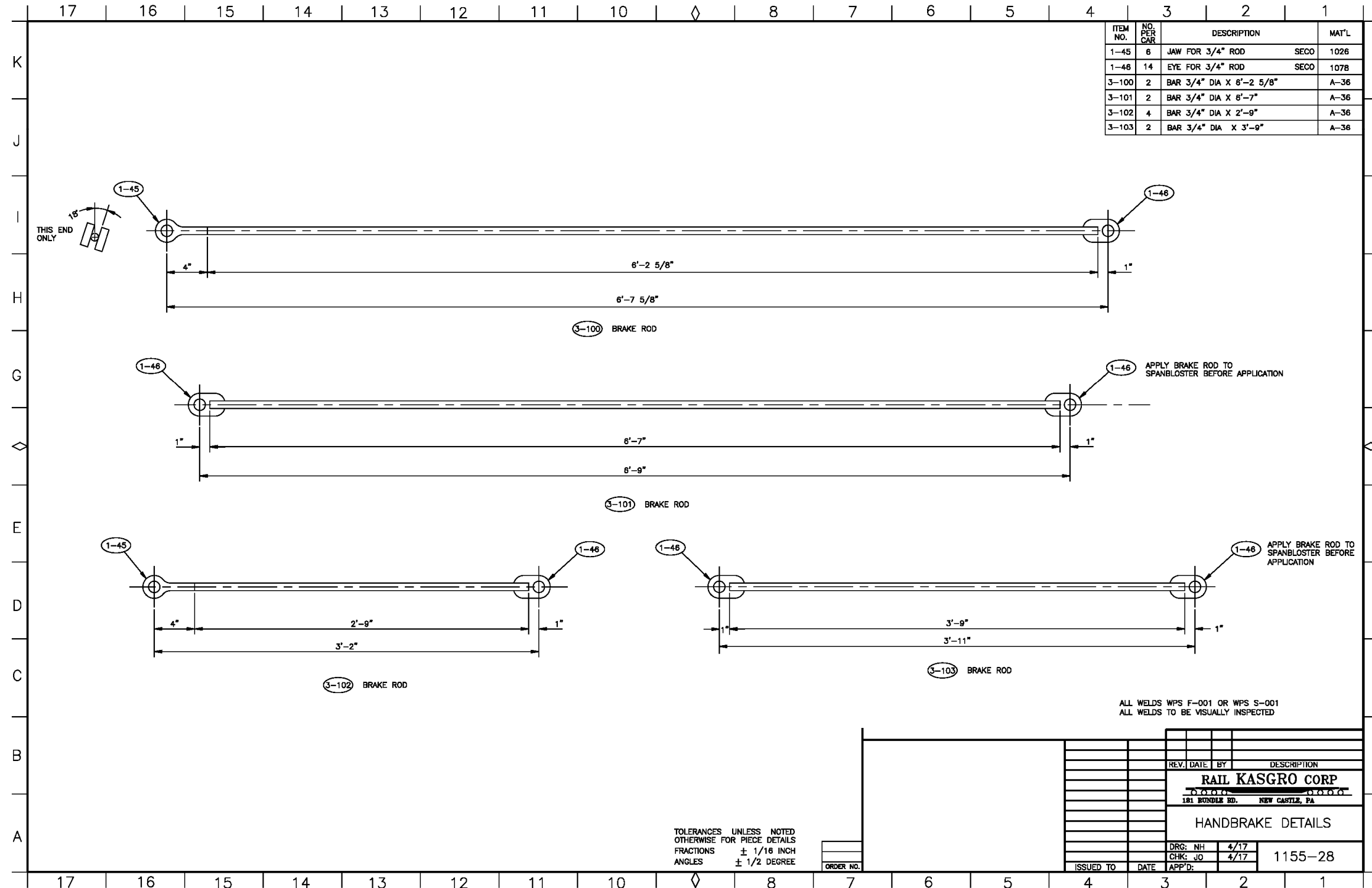

APPENDIX A.31 GRAB IRONS

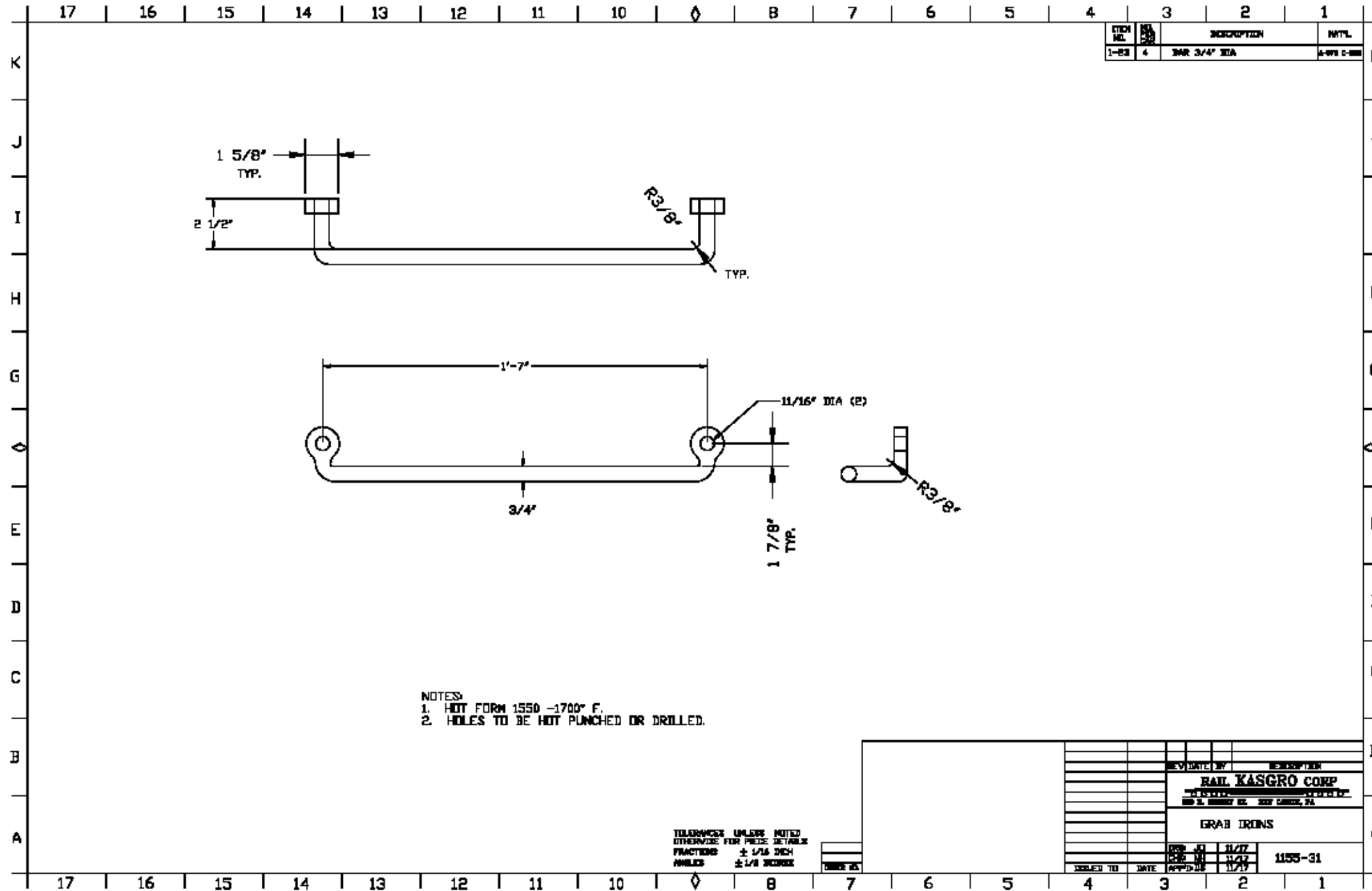

APPENDIX A.33 BRAKE STEEL DETAILS

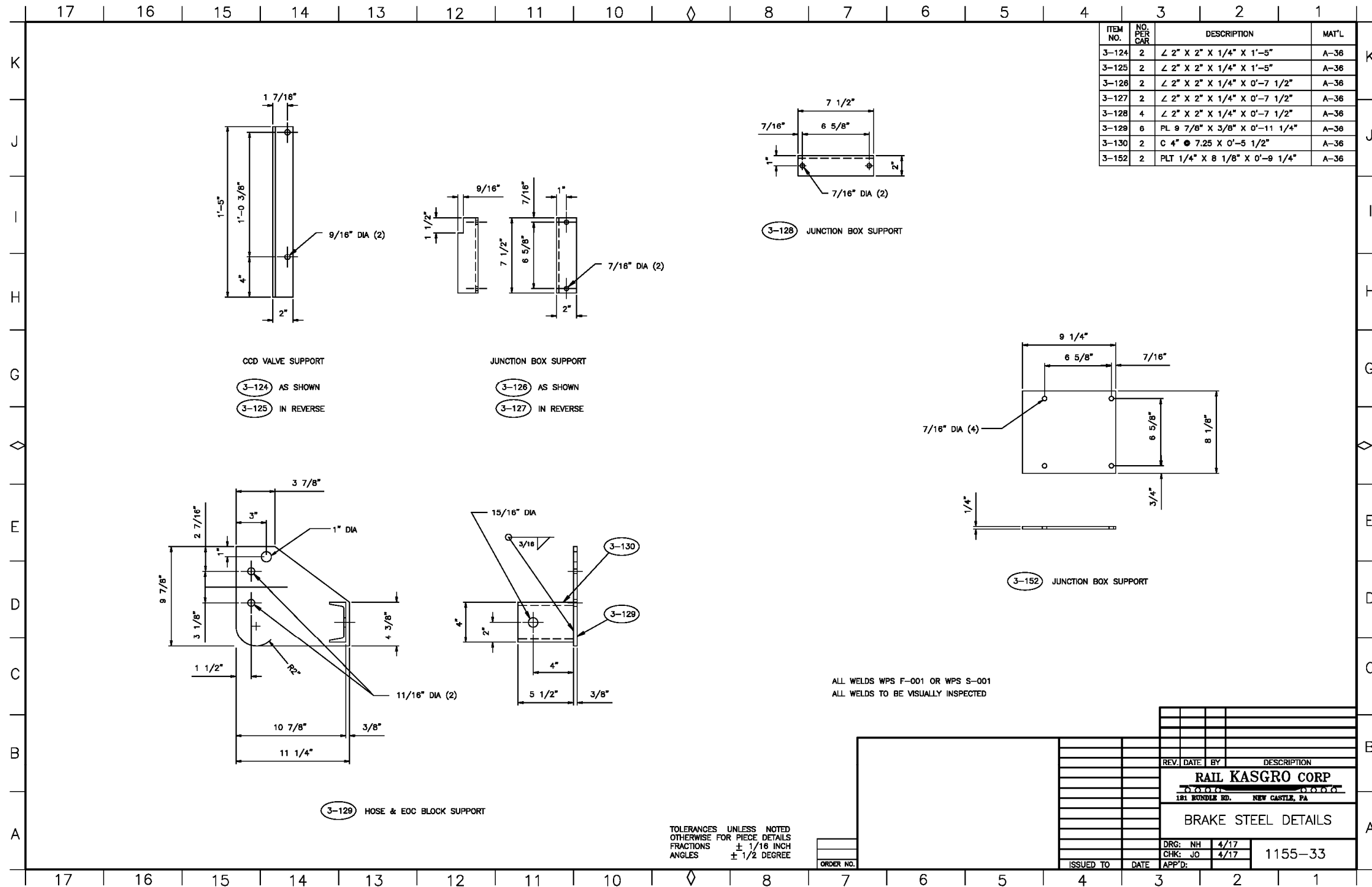



Orano Federal Services
Title: Design and Prototype Fabrication of Railcars for Transport of
High-Level Radioactive Material Phase 3 – Prototype Fabrication and Delivery
Appendix A

Doc./Rev.: EIR-3021970-000
 Project: 00225.03.0050 DOE Atlas Project

APPENDIX A.34 CAMBER DIAGRAM

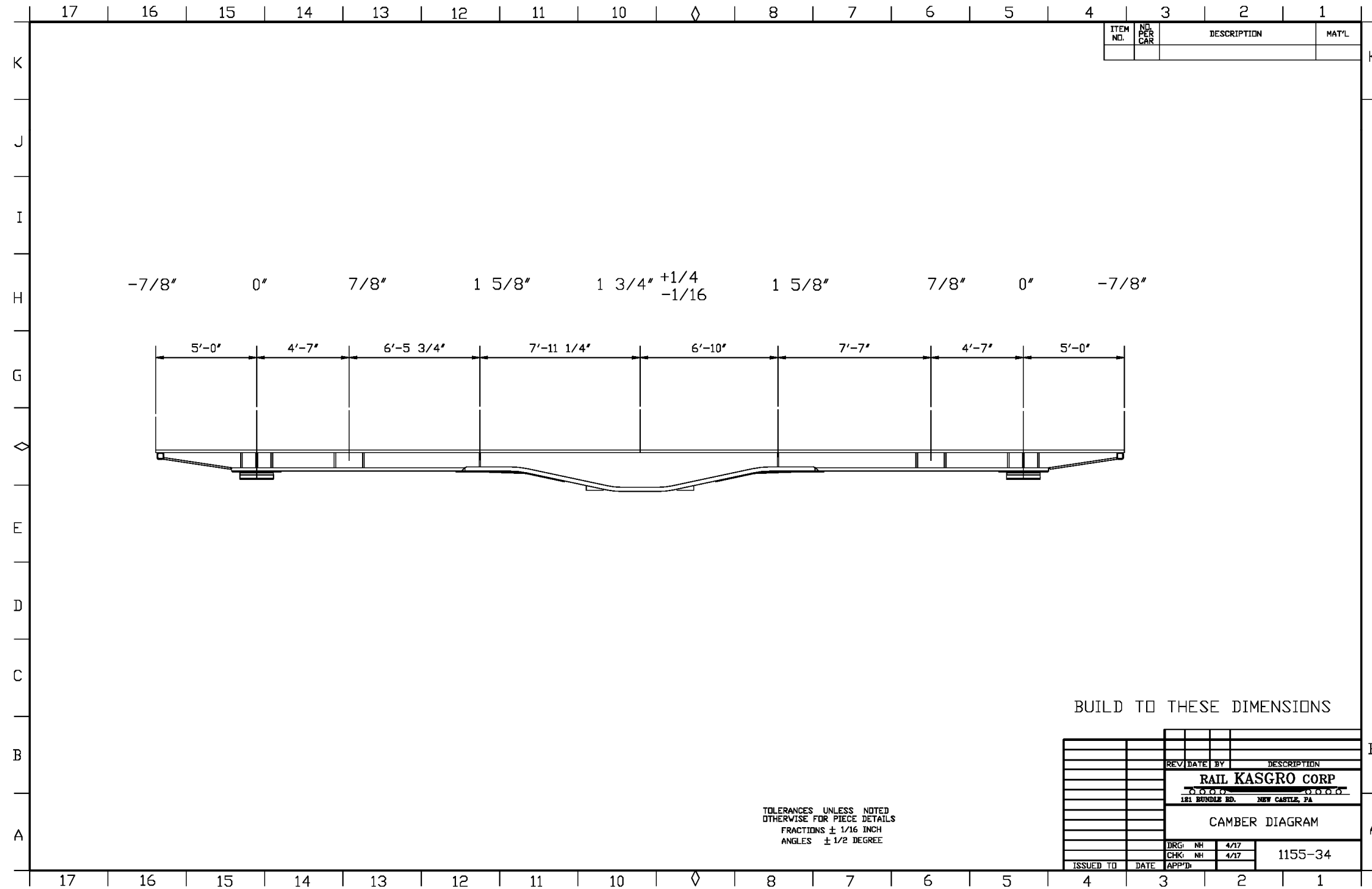

APPENDIX A.36 STEEL DETAILS

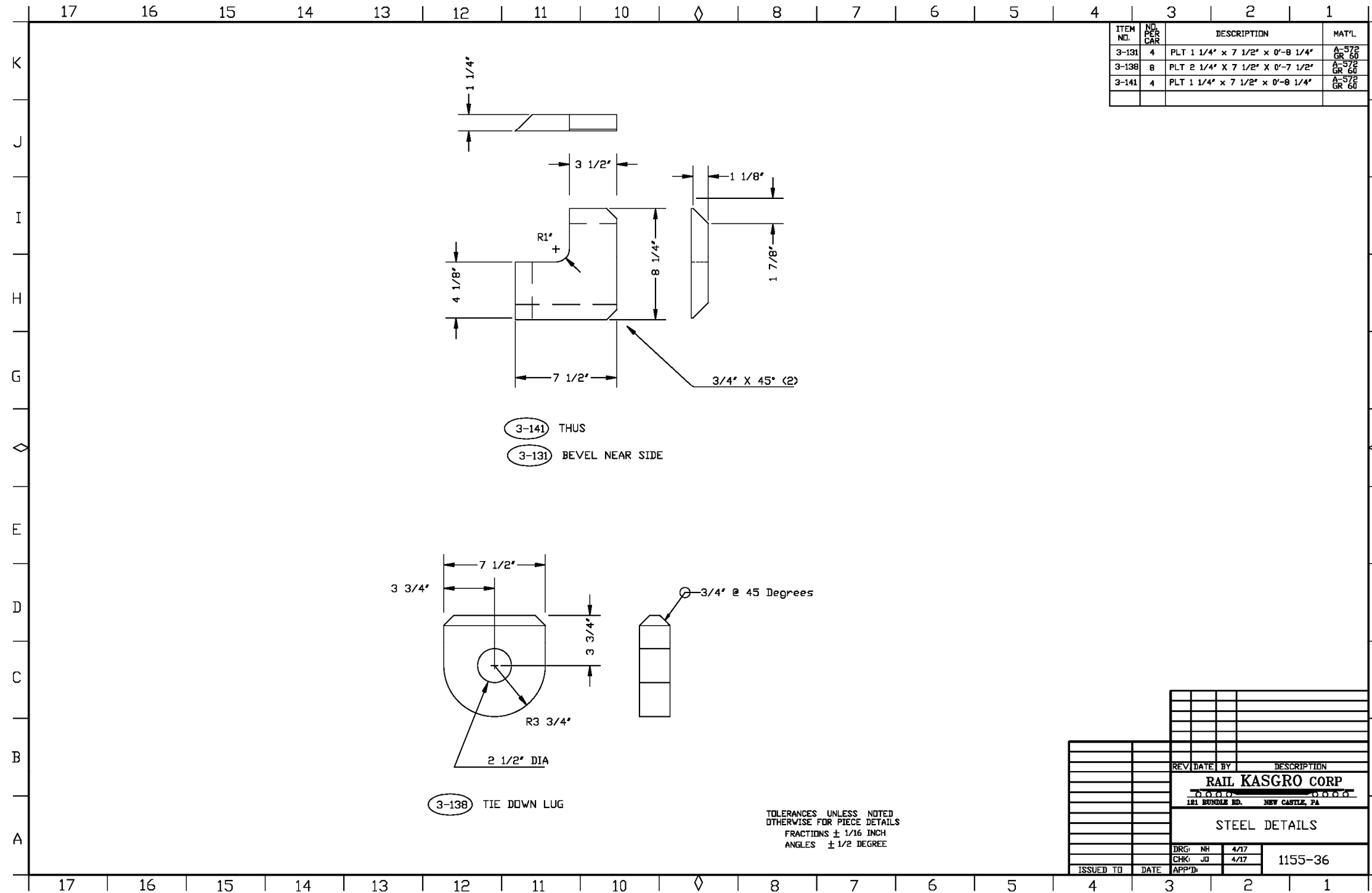



Orano Federal Services
 Title: Design and Prototype Fabrication of Railcars for Transport of
 High-Level Radioactive Material Phase 3 – Prototype Fabrication and Delivery
 Appendix A

Doc./Rev.: EIR-3021970-000
 Project: 00225.03.0050 DOE Atlas Project

APPENDIX A.37 STEEL DETAILS

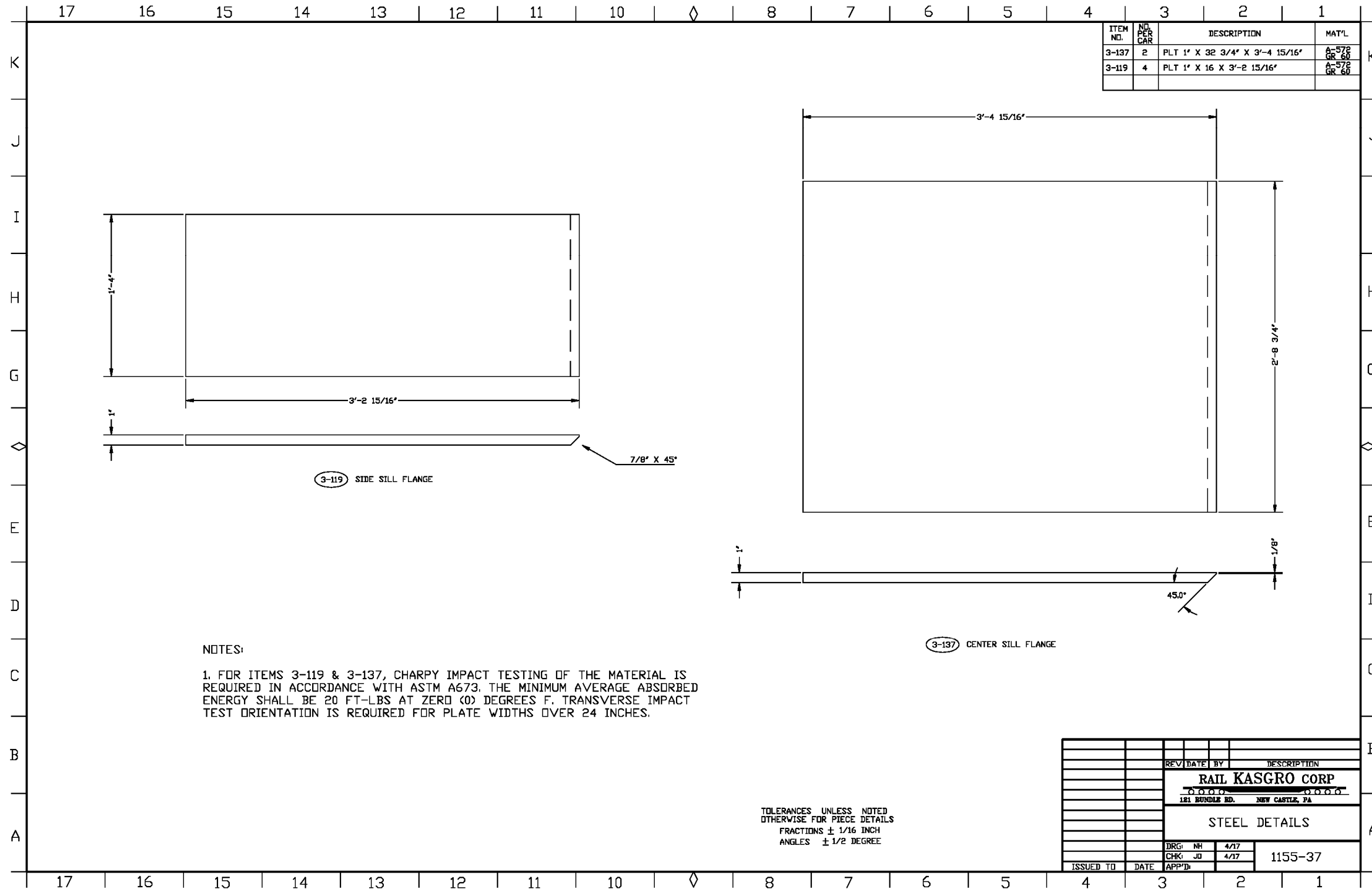

APPENDIX A.40 HANDBRAKE ARRANGEMENT

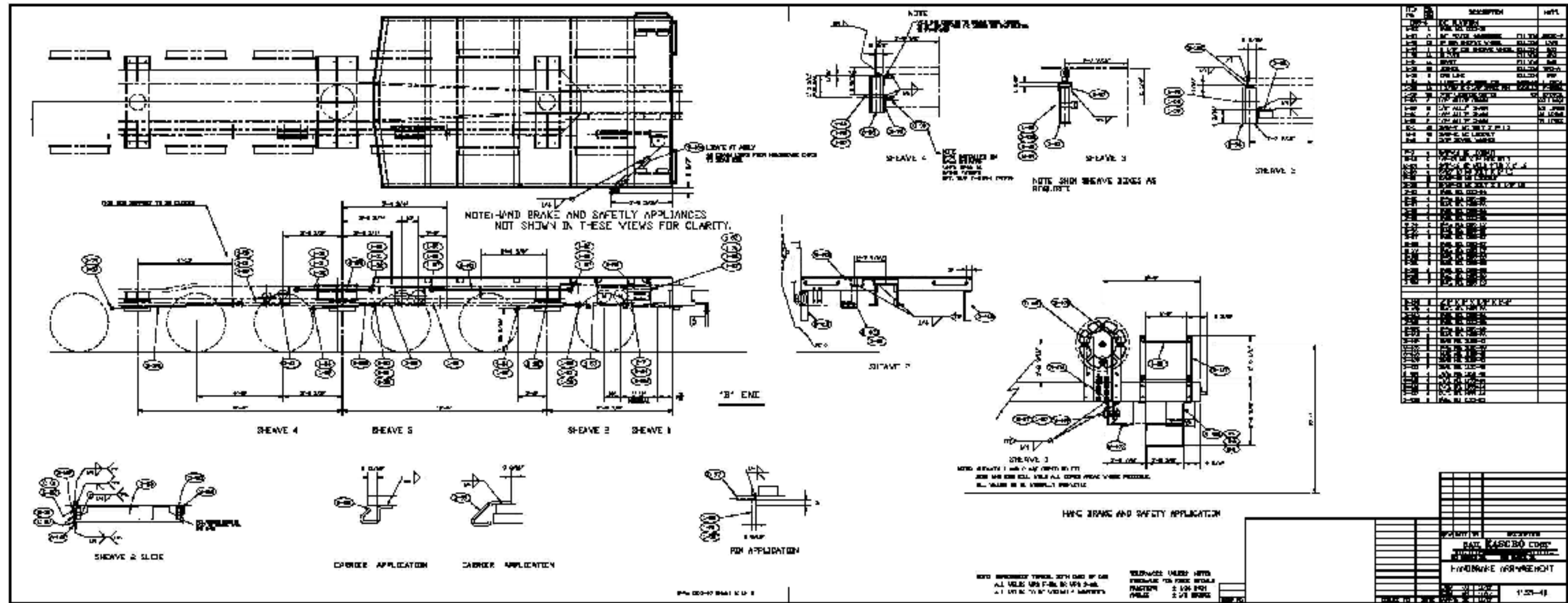

APPENDIX A.41 ATTACHMENT ARRANGEMENT

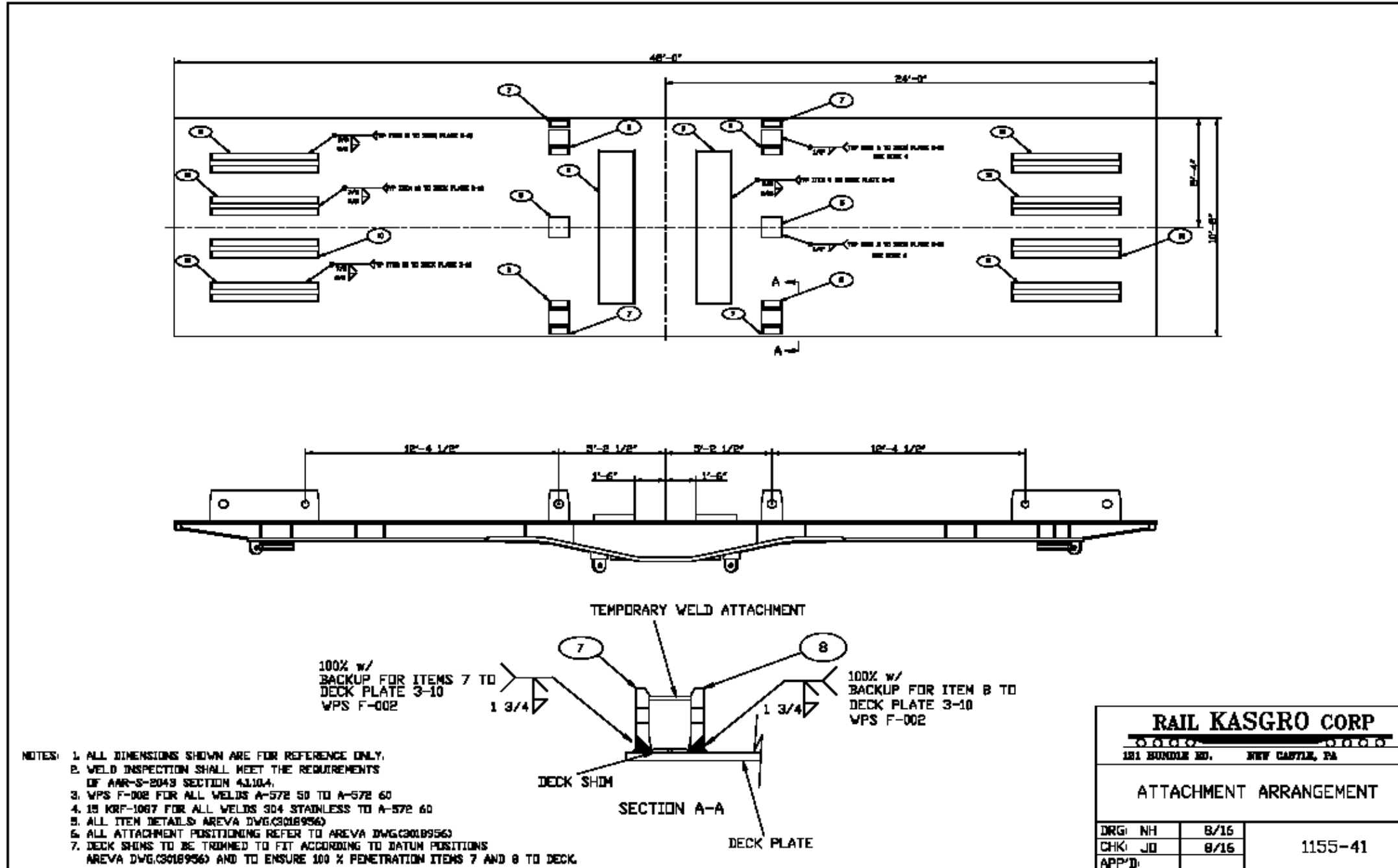

APPENDIX A.42 SHEAVE BRKTS

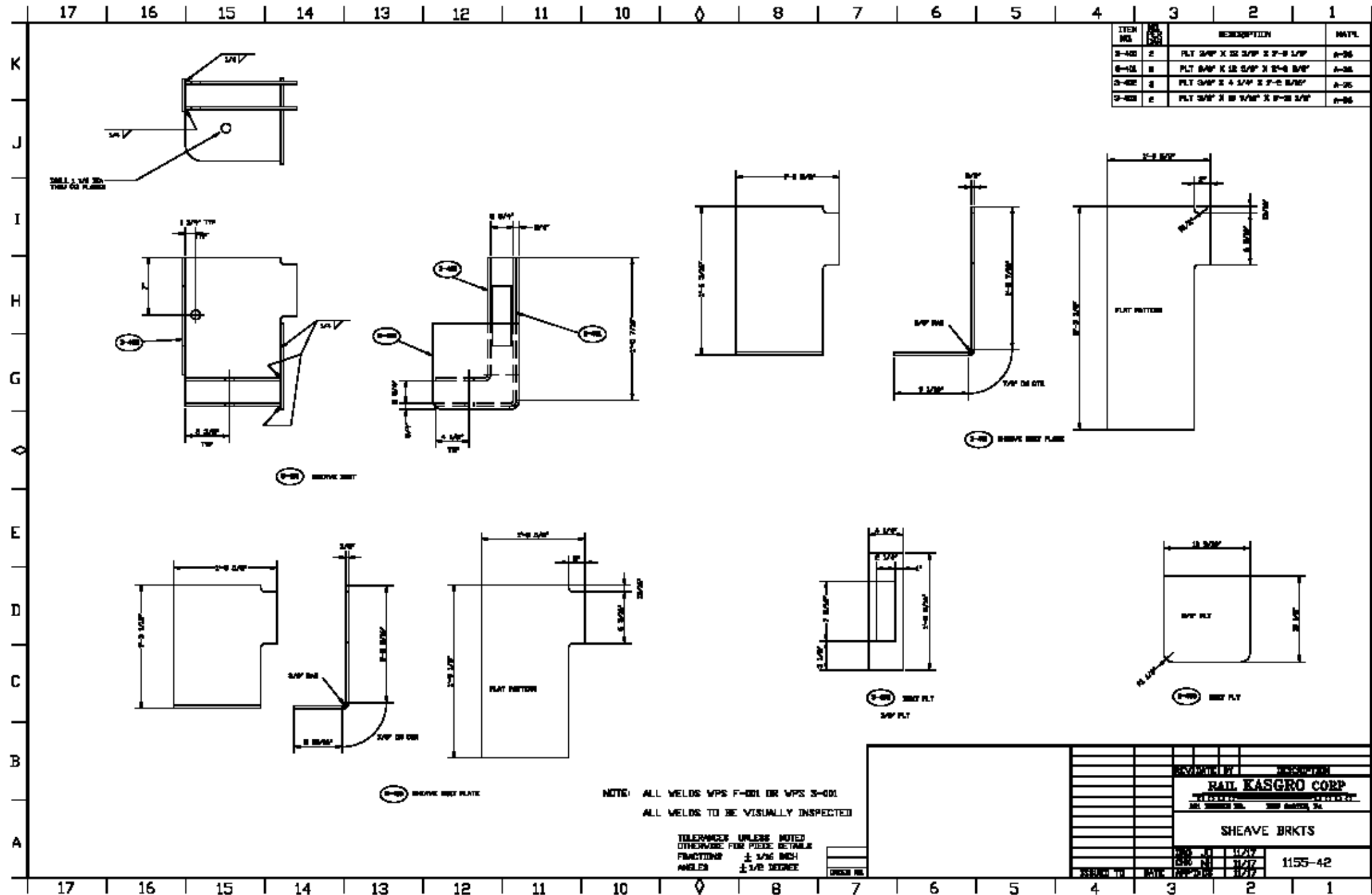

APPENDIX A.43 HB (HANDBRAKE) STEEL DETAILS

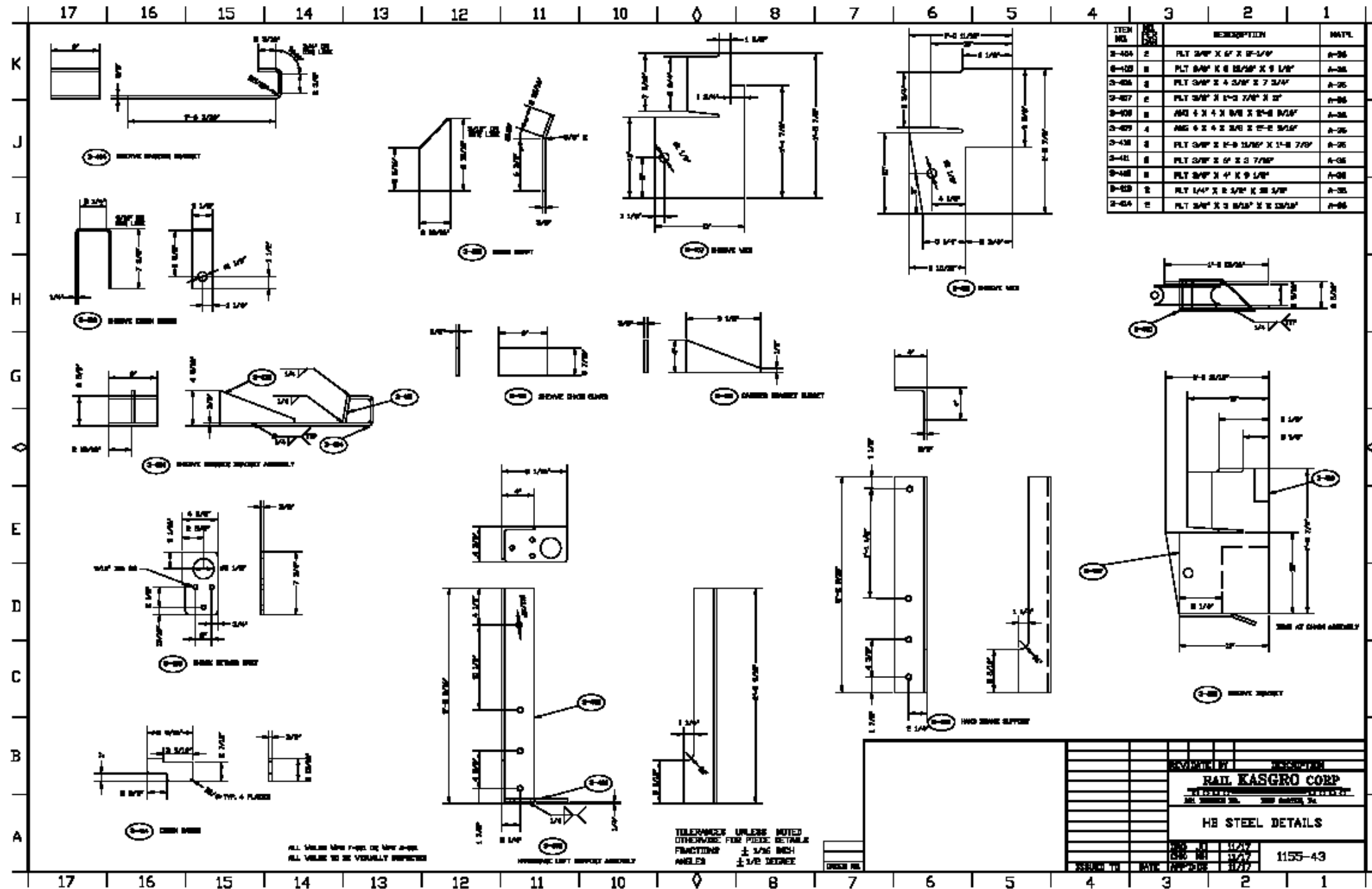

APPENDIX A.44 STEPS

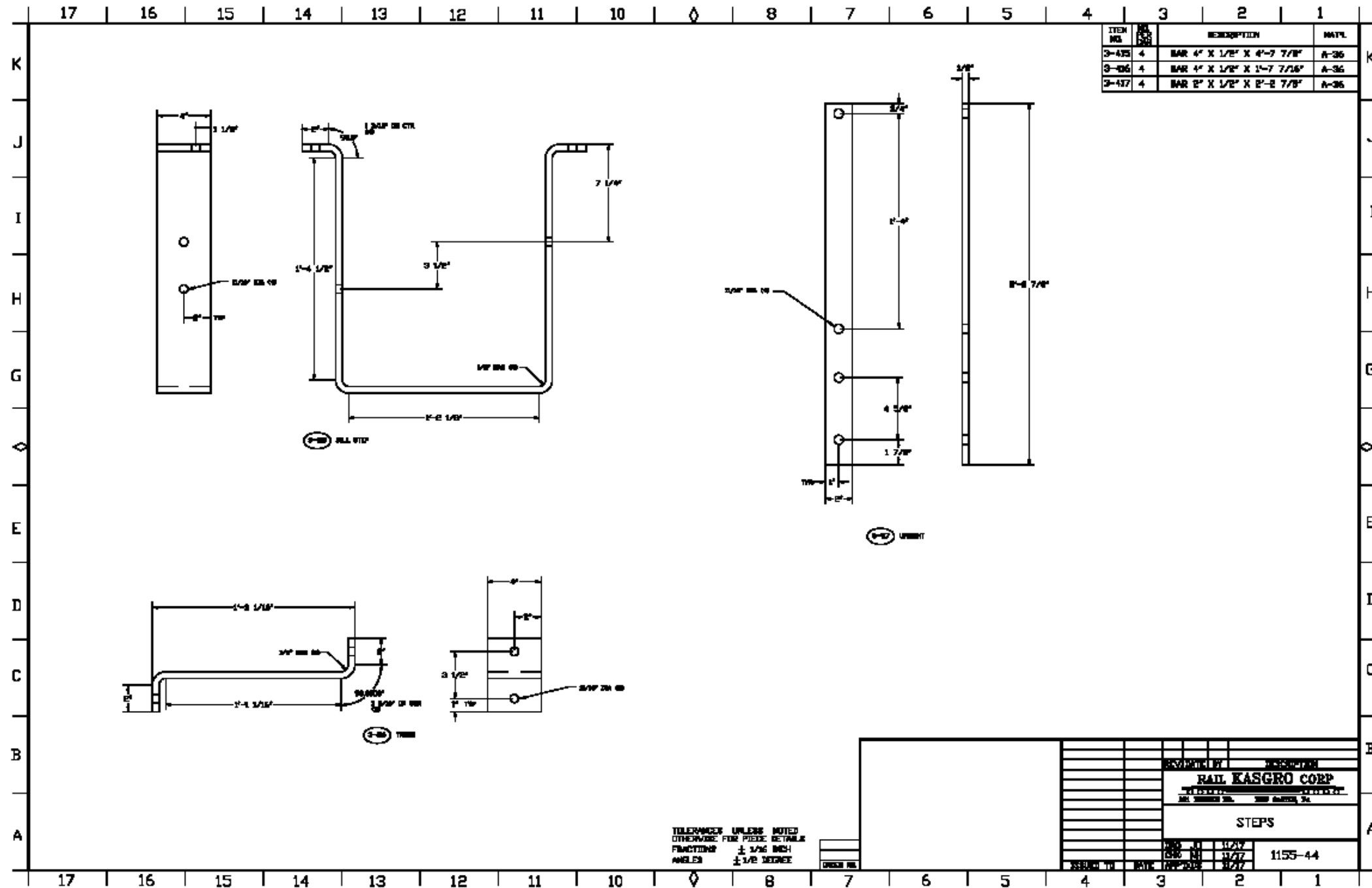



Orano Federal Services
Title: Design and Prototype Fabrication of Railcars for Transport of
High-Level Radioactive Material Phase 3 – Prototype Fabrication and Delivery
Appendix A

Doc./Rev.: EIR-3021970-000
Project: 00225.03.0050 DOE Atlas Project

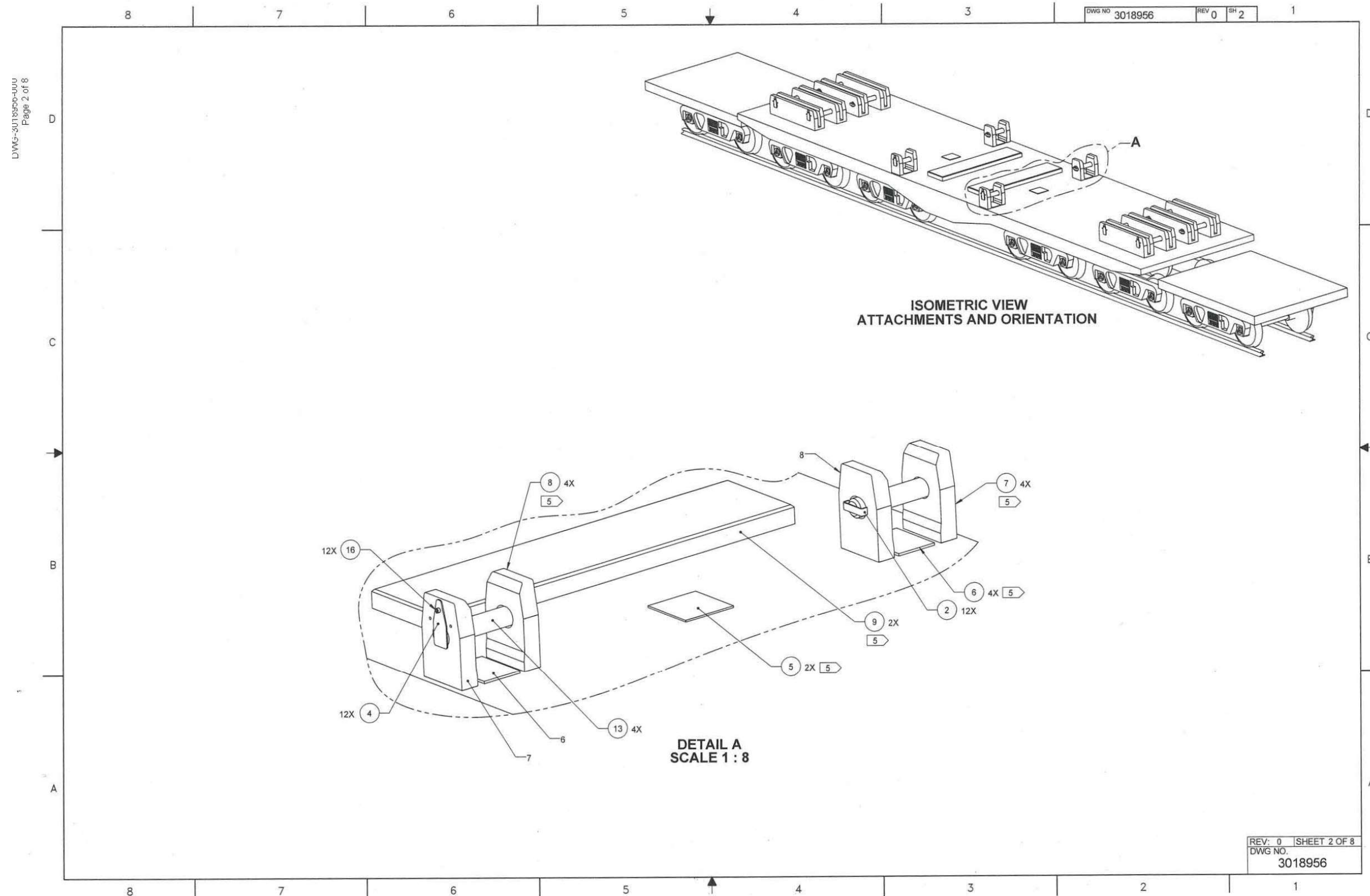

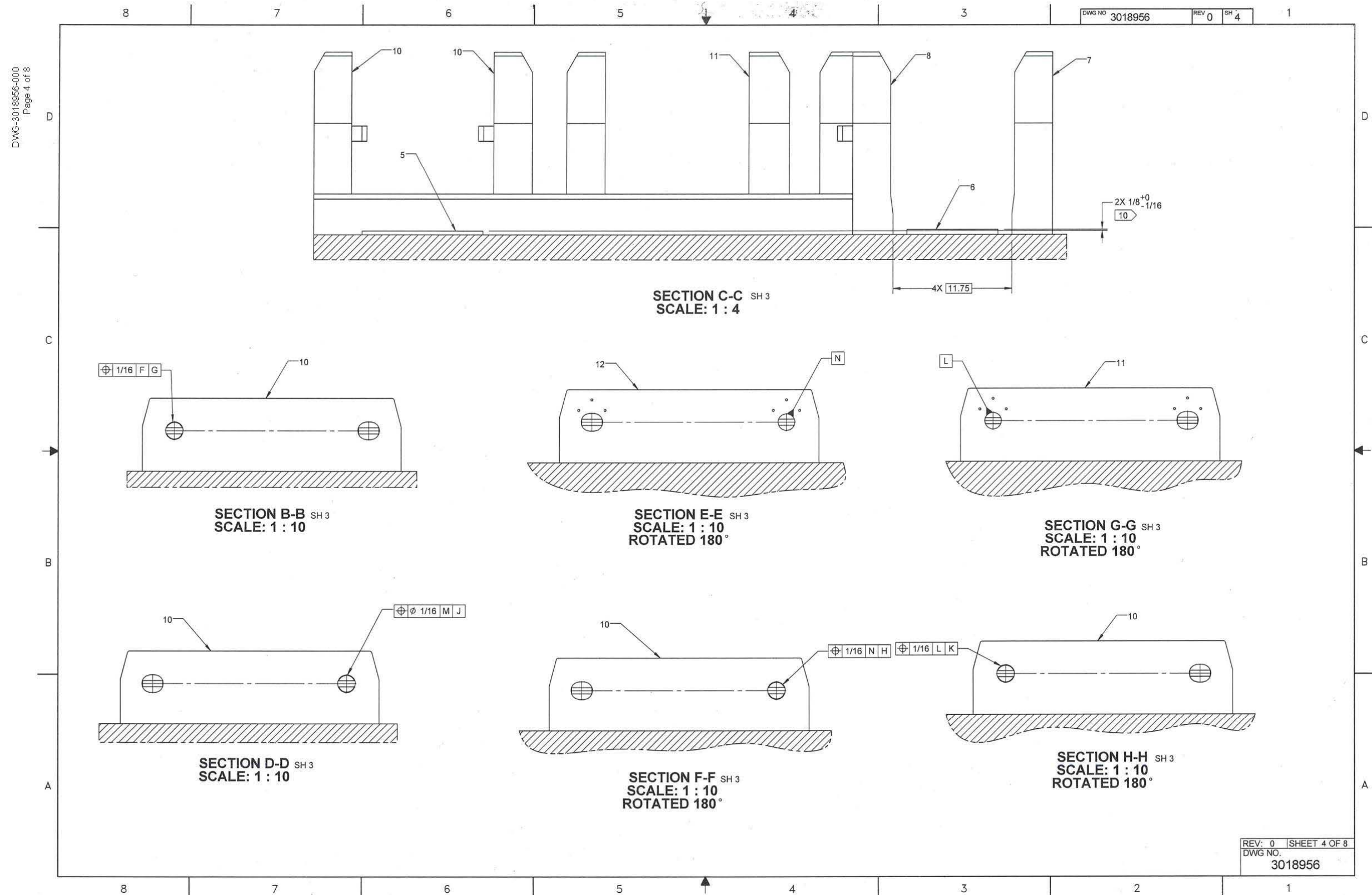

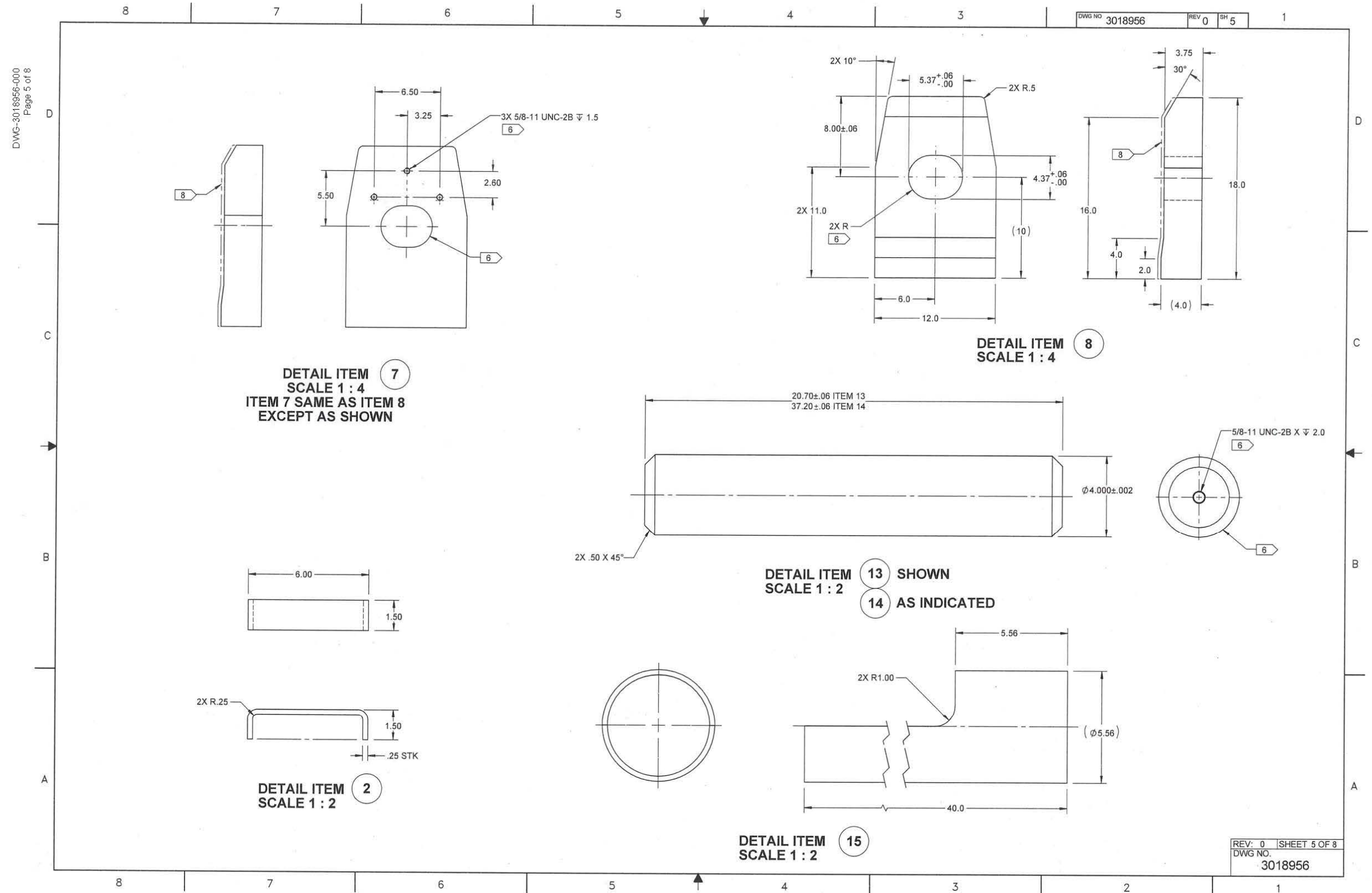



Orano Federal Services
Title: Design and Prototype Fabrication of Railcars for Transport of
High-Level Radioactive Material Phase 3 – Prototype Fabrication and Delivery
Appendix A

Doc./Rev.: EIR-3021970-000
Project: 00225.03.0050 DOE Atlas Project

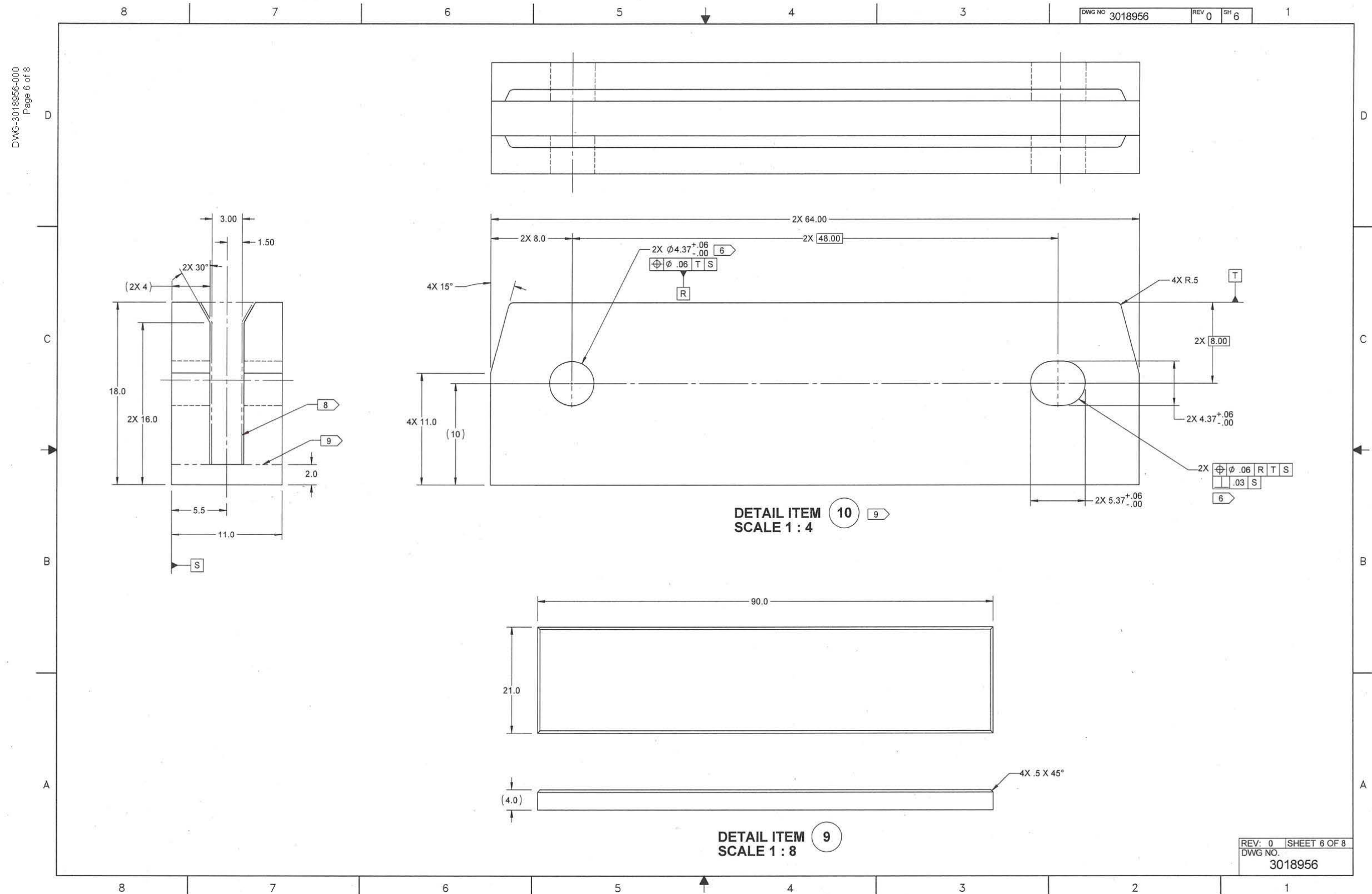



Orano Federal Services
 Title: Design and Prototype Fabrication of Railcars for Transport of
 High-Level Radioactive Material Phase 3 – Prototype Fabrication and Delivery
 Appendix A

Doc./Rev.: EIR-3021970-000
 Project: 00225.03.0050 DOE Atlas Project

