

Evaluation of Safe Refrigerant Charge Limits for Flammable Refrigerants

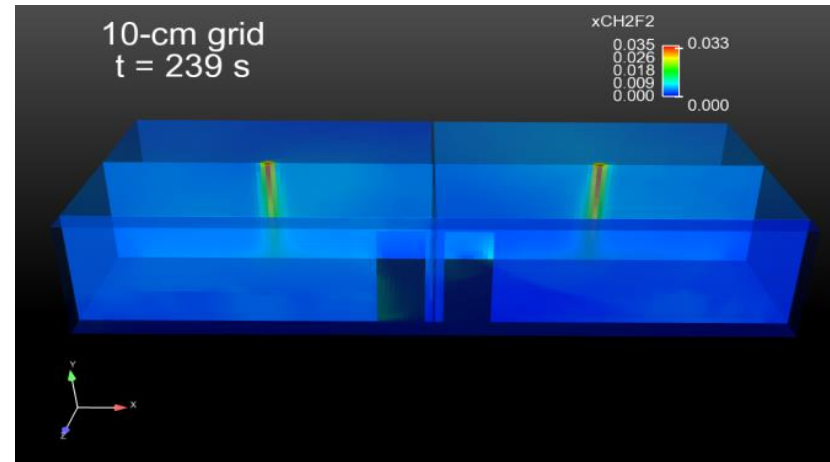

Oak Ridge National Laboratory
Van Baxter, Distinguished R&D Engineer
vdb@ornl.gov – 865-574-2104

Project Summary

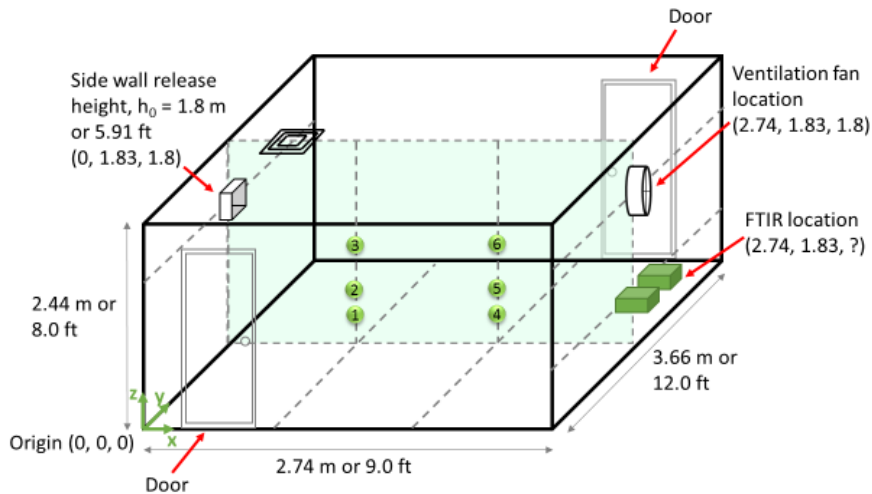

Key Partners:

Air Conditioning,
Heating, and
Refrigeration
Technology Institute
(AHRTI)

American Society of
Heating,
Refrigerating, and Air
Conditioning
Engineers

Timeline:

Start date: 06/01/2016

Planned end date: 09/30/2017 orig; 9/30/2019 actual

AHRI/ASHRAE/CA/DOE collaboration, initiated 2016

Key Milestones

1. Workshop with key stakeholders: 10/31/2016
2. Computational Fluid Dynamics (CFD) simulation campaign: 06/30/2017 orig; 4/30/2018 actual
3. Develop reduced order model (ROM) for charge limit estimation; 9/30/2017 orig; 9/30/2018 actual
4. Submit a draft for the final report; 09/30/2017 orig; 2/28/2018 (Part 1) and 11/30/2018 (Part 2) actuals

Budget:

Total Project \$ to Date:

- DOE: \$1M
- Cost Share: \$0

Total Project \$:

- DOE: \$1M
- Cost Share: \$0

Project Outcome:

- Develop analytical tools for relatively quick estimation of safe flammable refrigerant charge limits.
- Enable wider use of environmentally friendly refrigerants with potential for 90+% reduction of direct, refrigerant-related global warming impact.

Team

Within DOE, ORNL is the center of excellence in commercial and residential building equipment R&D along with supporting analysis tool development

Team members for this project include:

- **Dr. Dean Edwards, Dr. Charles Finney, Dr. Miroslav Stoyanov**—CFD modeling/simulation, ROM development
- **Dr. Ahmad Abu-Heiba**—Stakeholder workshop coordination, literature review, ROM development
- **Dr. Viral Patel**—Stakeholder workshop coordination, literature review, reports coordination
- **Dr. Ahmed Elatar and Dr. Mingkan Zhang**—CFD modeling/simulation
- **Dr. Omar Abdelaziz and Van Baxter**—Project managers/principal investigators, overall project direction, reports coordination



Challenge

Problem Definition:

- Pressure mounting to reduce use of high global warming potential (GWP) refrigerants
 - Kigali amendment to Montréal Protocol limits **developed nations** (e.g., Non Article 5) use of high GWP refrigerants (e.g., R-410A) to 15% of base levels by 2036
 - Nearly all lower GWP alternatives to R-410A flammable to some extent (A2L, A2, or A3)
- Safety standards limit charge for HVAC&R systems using **any** flammable refrigerant

Key Need:

- Science-based analytical tools to enable the heating, ventilation, air-conditioning, and refrigeration (HVAC&R) industry to relatively quickly estimate safe charge limits for flammable refrigerants in HVAC&R applications
 - Enable adjustment to limits to facilitate wider use of flammable, lower GWP alternatives
- Goals of this early-stage supporting project:
 - Solicit industry stakeholder input to review/guide research approach and plans
 - Develop CFD model of refrigerant release into occupied space and run simulations over range of relevant parameters
 - Based on CFD results, develop ROMs for charge limit estimation

Kigali amendment negotiated in October 2016 and entered into force January 1, 2019

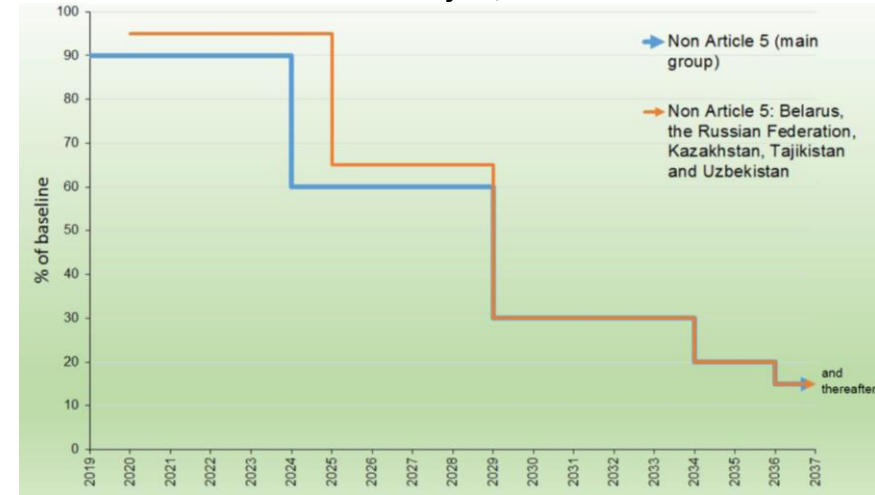

Source: <http://multimedia.3m.com/mws/media/1365924O/unep-fact-sheet-kigali-amendment-to-mp.pdf>.

Approach

- Industry engagement throughout project
 - Initial workshop to solicit input on needs and R&D approach
 - Added CFD validation element to project
 - Regular review meetings with AHRTI advisory group
 - Expanded scope to provide input for most recent ASHRAE 15.2 update
- Literature review (academic, codes, and standards) to determine key technology gaps and missing information
- Conduct CFD simulations using validated model of refrigerant release events for range of parameters
- Development of ROM(s) for relatively quick safe charge limit estimation

Impact

Impact of Project:

- National energy market for HVAC&R equipment using high GWP refrigerants amounts to ~7 Quad/year in 2030
 - ~2.4 Quad/year for residential space heating and AC alone (~\$30B/year @ 2018 avg elec price)
 - Success in achieving goals would provide the industry with tools to estimate appropriate flammable refrigerant charge limits
 - Enable wider use of efficient and environmentally friendly refrigerants with potential 90%+ reduction of direct refrigerant-related greenhouse gas (GHG) emissions
 - System evaluations by AHRI and DOE show potential for 10%+ improvement in energy efficiency with system optimization (~0.24 Q/year energy savings if these alternatives replace all R-410A and other legacy refrigerant-based residential heat pump and AC systems)
 - Produce publications informing national and international standards and codes developers
-
- ✓ Directly supports BTO Emerging Technologies 2016-20 MYPP
 - ✓ Goal—enable 45% reduction in building energy use intensity (EUI) in 2030 vs. 2010 EUI
 - ✓ HVAC/WH/Appliances Strategy 1: Near-Term Technology Improvement

Progress — Workshop

- Held in October 2016 at ASHRAE HQ in Atlanta, Georgia
- 40 stakeholders
 - HVAC&R, appliances, refrigerant manufacturers
 - Standards and codes development organizations
 - Industry and professional organizations
 - DOE, US Environmental Protection Agency (EPA), ORNL
- **Direct impact on project direction**
 - Added CFD simulation validation testing effort, a crucial addition as will be seen later
 - Focus CFD studies on several key parameters
 - Refrigerant charge, release rates, release location (height), ventilation rates, door openings, room size

Progress — Literature Review

Literature ~evenly split between experimental and analytical studies

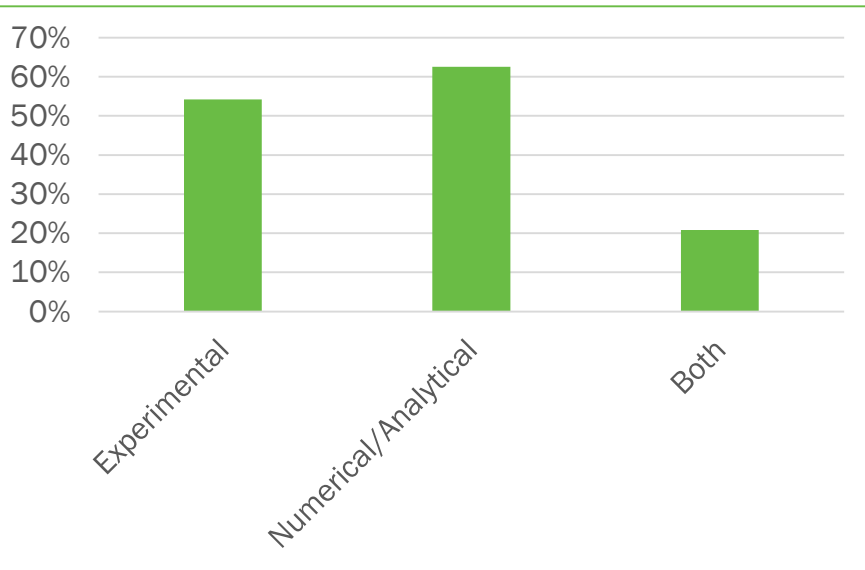

~80% dealt with residential-type split AC/HP systems

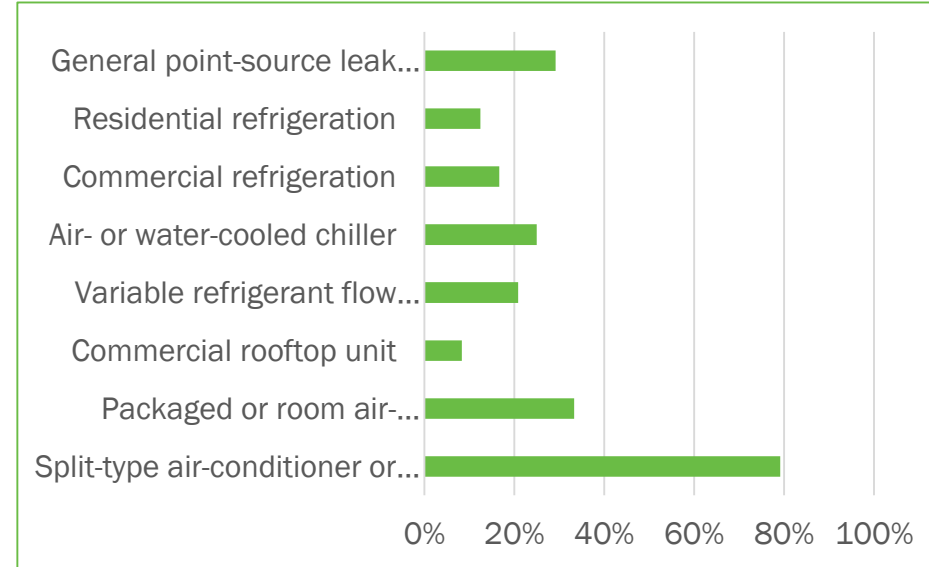

Some key R&D gaps identified

- Basing safety criteria on maximum refrigerant concentration in room can be misleading.
- What refrigerant leak rate assumption best typifies real refrigerant release events?

Progress — Literature Review

Why maximum concentration point as basis for safety can be misleading

- Maximum concentration as ratio of lower flammability limit (LFL) is plotted against total mass leaked as ratio of maximum charge mass per IEC-60335-2-40 (2016 version)
- Exceeding max charge limit did not necessarily result in maximum concentration in room exceeding LFL *at measurement points*
- Also, staying under max limit did not necessarily prevent refrigerant concentration from exceeding LFL *at measurement points*

Data from experimental studies—maximum concentrations at specific points monitored

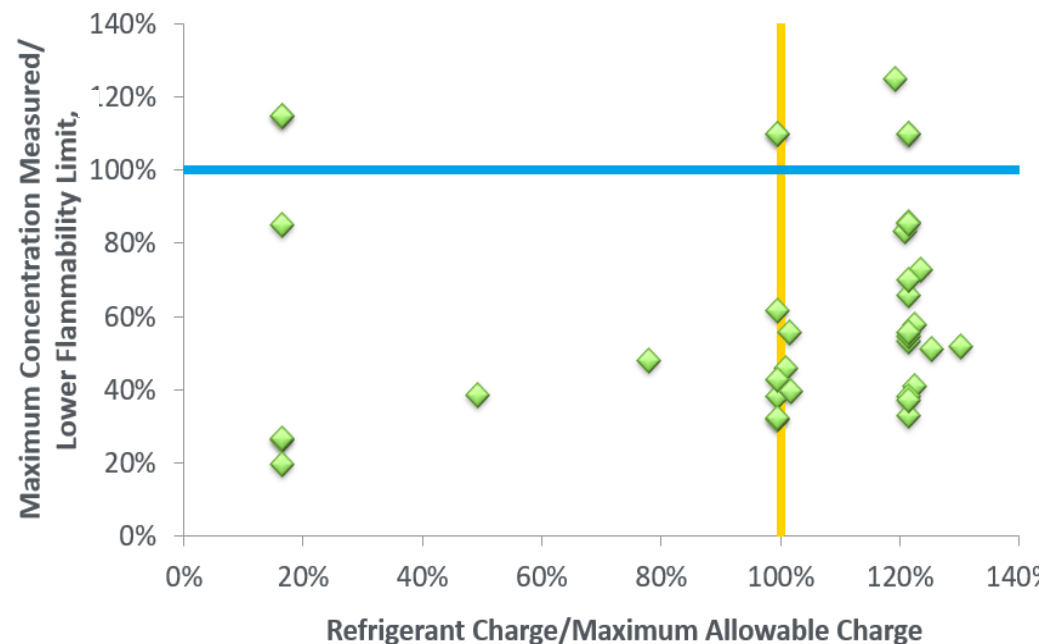

Key point:

Concentration is location dependent (will always be a flammable refrigerant/air mixture near leak release point)

Progress — Initial CFD Simulations/Validation

Accurate modeling of leak release is crucial

- Initial simulations assumed leak release profile across 1 ft² area - very low momentum waterfall pattern with most refrigerant pooling near floor
- Test observations show refrigerant entering room as a relatively high velocity plume—more mixing throughout
- Initial CFD results vs. data not good match

Dh = 0.305 m
t = 31 s
xCH2F2
0.60
0.45
0.30
0.15
0.00

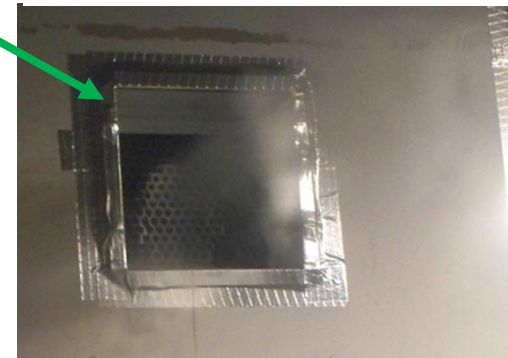
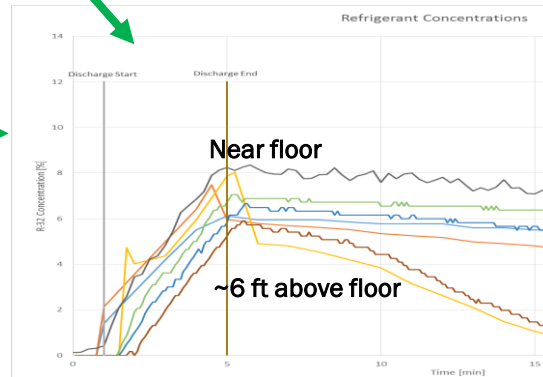
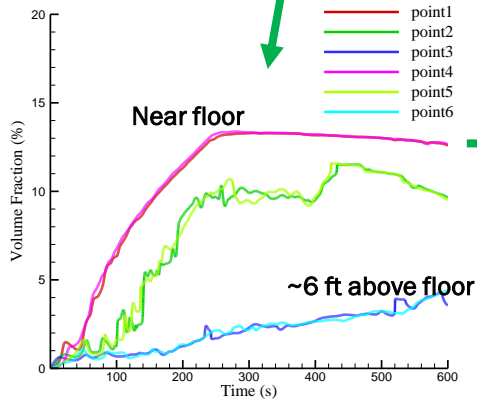
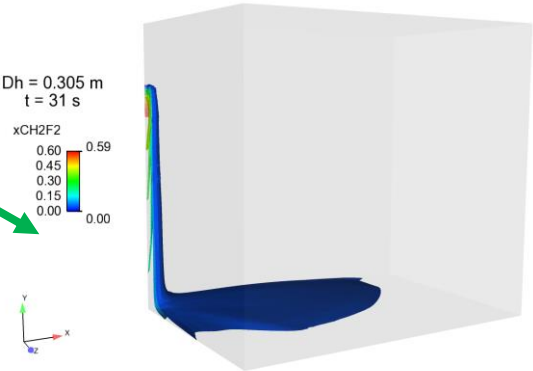

CFD model calibration to data; 1” hydraulic diameter (Dh) release orifice most closely replicated observed release profile

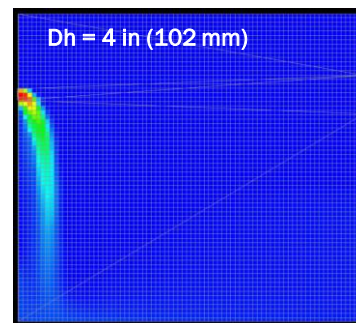
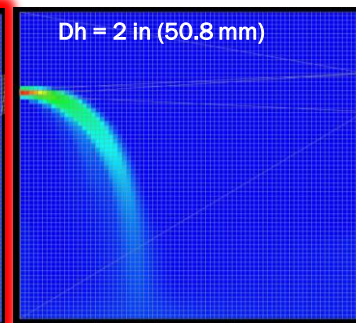
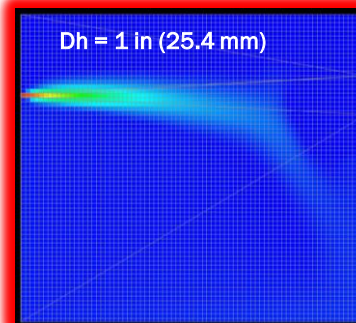

Progress — Initial CFD Simulations/Validation

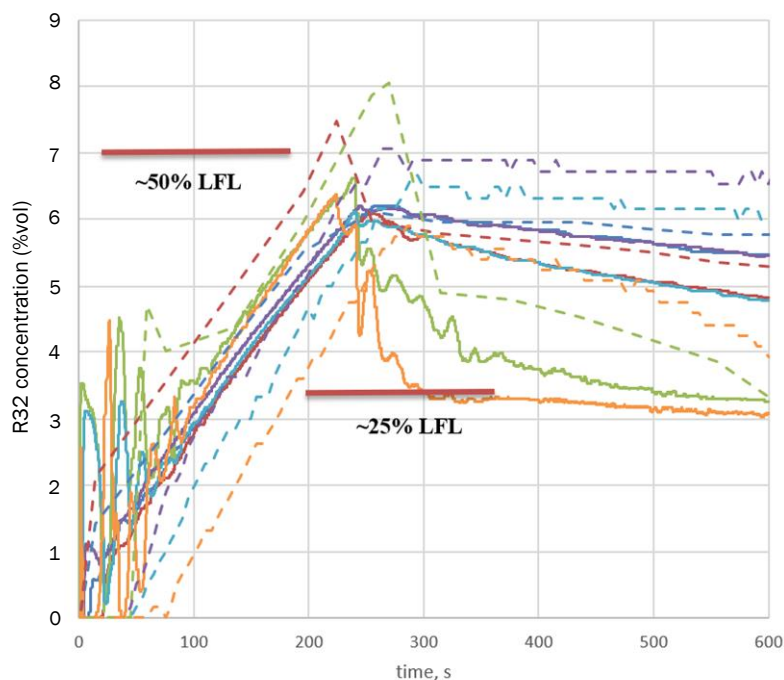

* See the six sample point (SP) locations in figure at right

NOTE: R-32 LFL = 14.4% per ASHRAE 34-2016

- R-32 release tests performed by Jensen-Hughes, Inc. under subcontract
- Test vs. simulation results for 1 in. (25 mm) hydraulic diameter leak release orifice
 - Dashed lines → measured refrigerant concentration at six sample points (SP)
 - Solid lines → predicted concentration from CFD simulation at same locations
- Simulations results fall within measurement uncertainty bands (+/- 4.5%)
- Room profile used for initial simulations and validation

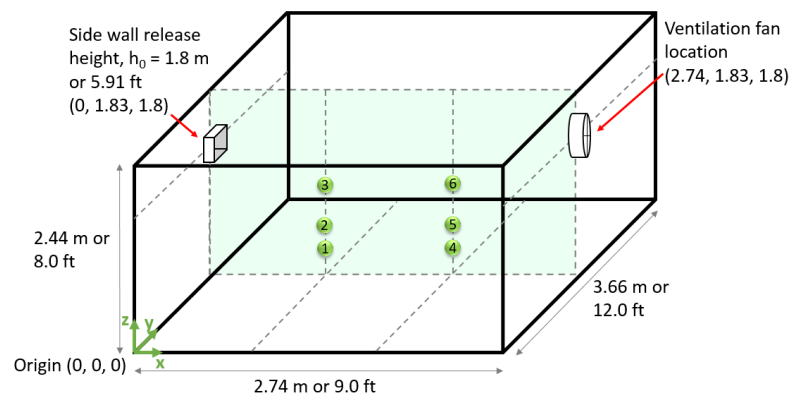

Progress — Multi-room Simulations

- Requested by ASHRAE 15.2 committee and AHRTI Project Monitoring Sub-committee (PMS)
- Simulation of leak from 3-ton package AC unit into an 1,800 ft² (167 m²), 4-room residence
 - 7 lb. (~3.2 kg) total refrigerant charge
- Ductwork and rooms simulated separately
 - Duct solution (flow rate and composition) imposed as boundary condition on room model
- Symmetry imposed to reduce computational demands by modeling only half the domain

Case	Refrigerant	Rooms open	Vent location	Fan status	Leak duration [s]
1	R-32	4	Floor	Off	240
2	R-32	4	Ceiling	Off	240
3	R-32	4	Floor	Off	17.8
4	R-452B	4	Floor	Off	240
5	R-32	0	Floor	Off	240
6	R-452B	0	Floor	Off	240
7	R-32	0	Floor	Off	17.8
8	R-32	0	Floor	On	17.8
9	R-32	2	Floor	Off	17.8

Building geometry model

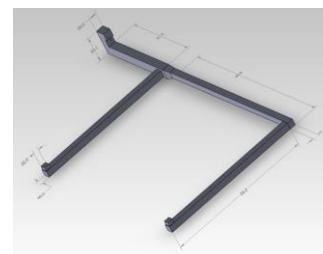
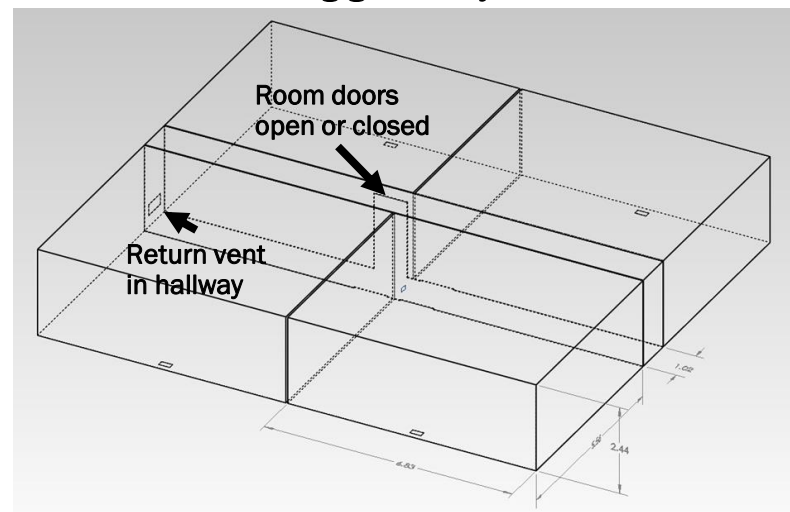

Floor duct geometry, AC unit in crawlspace

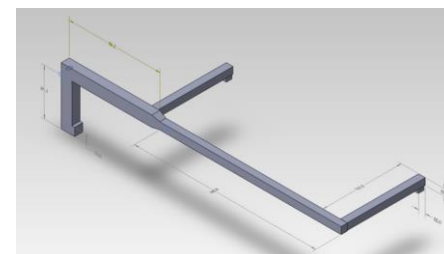

Ceiling duct geometry, AC unit in attic

Progress — Multi-room, Key Results

Floor ducts, fan off, 4 min release (case 3):

- >99% of refrigerant (R-32) stays in ducts
 - Flammable concentrations in branch ducts (concentration between LFL and UFL*)
 - Concentration >UFL in main duct

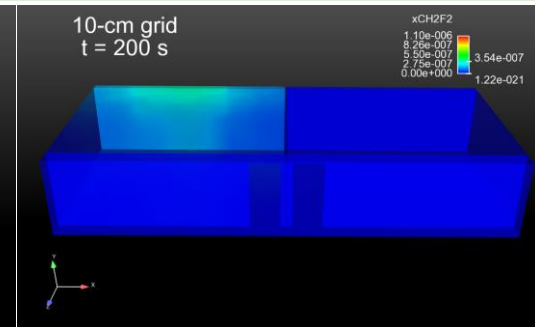
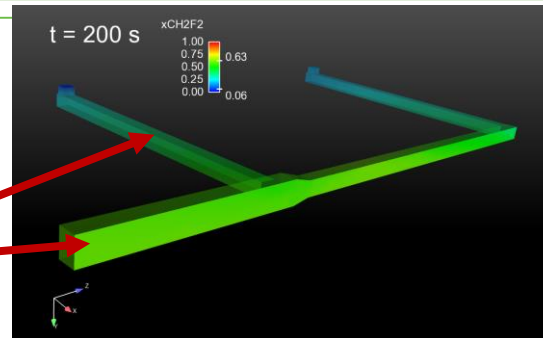

Floor ducts, fan on, 18s release (case 8):

- Refrigerant forced out of duct quickly
- Max concentrations during release:
 - ~25% in duct
 - <6% in rooms near duct outlets

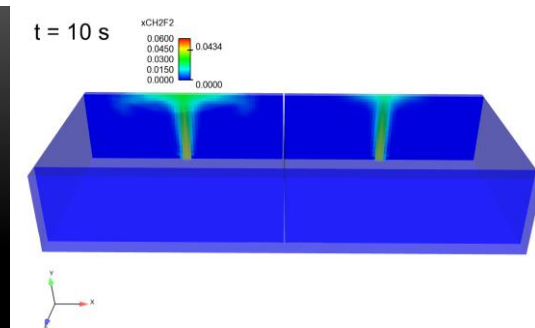
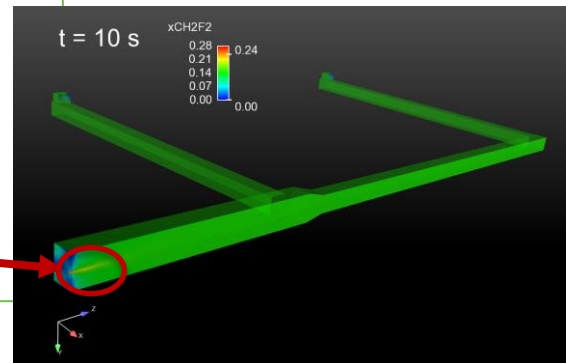

- **Refrigerant dispersed quickly (<1% everywhere after ~60s)**

Ceiling ducts, fan off, 4 min release (case 2):

- Gravity forces refrigerant into rooms
- Maximum concentrations
 - ~15% in duct during leak, near leak point
 - ~3.5% in rooms under duct outlets

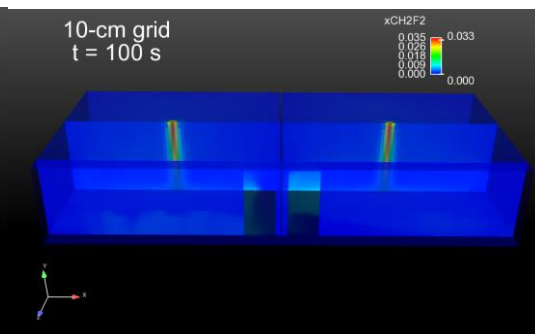

***NOTE: R-32 LFL = 14.4% per ASHRAE 34-2016; upper flammability limit (UFL) 28-33% (various sources)**

Progress — ROM Development

- **Sparse-grid approach with TASMANIAN*** to reduce number of CFD cases to be run over parameter ranges
 - Factorial approach: ~12,000 CFD case matrix
 - Sparse-grid approach: ~500 CFD case matrix
 - Some cases took *months* of calendar time to complete
- **TASMANIAN “curve-fits” the matrix to an n-dimensional, continuously differentiable mathematical function (aka, the ROM)**
- **Two ROMs**
 - Unit fan off (complete): expect higher max refrigerant concentrations
 - Unit fan on: expect more even dispersion of refrigerant in space

Parameter inputs	Range considered
Unit fan	Off / On
Room floor area*	5 – 20 m ²
Leak height	0 – 2.438 m
Open door area	0.01 – 1.96 m ²
Ventilation rate	0 – 576 cfm
Leak rate	1.875 – 34.2 kg/min
Total charge	0.1 – 11.275 kg
MW of refrigerant	44 – 144 kg/kmole

ROM outputs:

- Refrigerant concentration: Min, max, and room mean at 5, 10, 20, 50, 100, 200, 300, 400, 500, 600 s
- Flammable volume (% of total room volume) for LFL/UFL combinations of fifteen different flammable refrigerants
- Fraction of total room volume with >LFL concentration (aka fuel volume), for multiple LFLs

ROM comparison to CFD results:

- CFD “test” cases
- Avg. refrigerant concentration for CFD (solid lines) and ROM (dashed lines)
- ROM results track CFD results well for this parameter
- **Room ventilation reduces concentration**

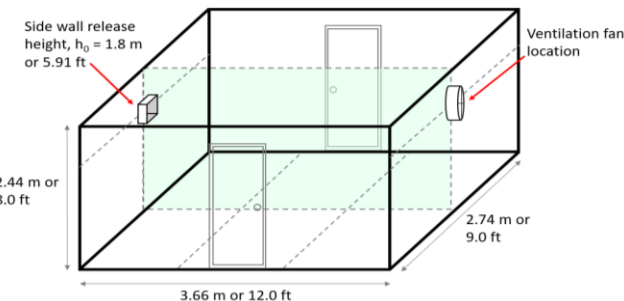
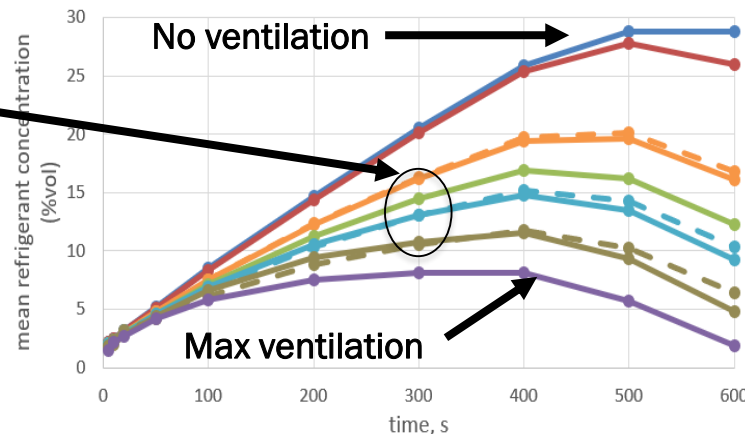

***NOTE: Room aspect ratio and height held constant**
Simulation symmetry plane in pale green

* **TASMANIAN: Toolkit for Adaptive Stochastic Modeling And Non-Intrusive Approximation**
 Developed at ORNL with funding from the DOE Office of Science

Stakeholder Engagement

- Project near completion, 95+% complete
- Two primary stakeholder engagement efforts:
 - Early workshop helped focus project approach including key advice regarding CFD simulation tool validation
 - Regular meetings with AHRTI PMS
- Project summaries presented
 - ASHRAE 15.2 committee meeting, January 2018
 - AHRTI Flammable Refrigerants Research and Planning Conference, October 2018
- **Key takeaway: maintaining room air circulation via AC fan or room vent fan is very effective for reducing maximum refrigerant concentrations in release event**

Primary publications:

- ***Methodology for Estimating Safe Charge Limits of Flammable Refrigerants in HVAC&R Applications–Part 1***, ORNL/TM-2018/804, June 2018 (release date)
- ***Methodology for Estimating Safe Charge Limits of Flammable Refrigerants in HVAC&R Applications–Part 2***, ROM Development, ORNL/TM-2018/1066, March 2019 (release date)

Remaining Project Work

Finalize and document unit “fan on” ROM version; goal to distribute report in FY 2019

Thank You

Oak Ridge National Laboratory
Van D. Baxter, Distinguished R&D Engineer
865/574-2104; vdb@ornl.gov

REFERENCE SLIDES

Project Budget

Project Budget: Started the project in July 2016; \$950k budget from FY16 and FY17 AOP.

Variiances: two additional but important tasks added based on stakeholder feedback & requests; CFD simulations took longer than anticipated for some scenarios essential to ROM development; project completion delay largely due to impact of these variances

Cost to Date: 100% of project budget expended (finishing on donated time).

Additional Funding: none anticipated.

Budget History

FY 2016-2018 (past)		FY 2019 (current)		FY 2020 (planned)	
DOE	Cost-share	DOE	Cost-share	DOE	Cost-share
\$974k	\$0	\$26k	\$0	\$0	\$0

Project Plan and Schedule

- Project initiation date July 2016; planned completion date September 2019
- Key milestones indicated below
- See previous slide for explanation of schedule deviations

Project Schedule												
Project Start: July 2016	Completed Work											
Projected End: September 2019	Active Task (in progress work)											
	◆ Milestone/Deliverable (Originally Planned)											
	◆ Milestone/Deliverable (Actual)											
	FY2017				FY2018				FY2019			
Task	Q1 (Oct-Dec)	Q2 (Jan-Mar)	Q3 (Apr-Jun)	Q4 (Jul-Sep)	Q1 (Oct-Dec)	Q2 (Jan-Mar)	Q3 (Apr-Jun)	Q4 (Jul-Sep)	Q1 (Oct-Dec)	Q2 (Jan-Mar)	Q3 (Apr-Jun)	Q4 (Jul-Sep)
Past Work												
Initial Stakeholder workshop (October 2016)	◆											
Finalize CFD simulation campaigns for ROM dev.			◆			◆						
Complete CFD simulations & dev. "fan off" ROM				◆					◆			
Complete draft Part 1 report (Initial CFD & val.)				◆		◆						
Complete draft Part 2 report ("fan off" ROM)				◆					◆			
Current/Future Work												
Complete CFD simulations & dev. "fan on" ROM				◆								◆
Complete draft Part 3 report ("fan on" ROM)				◆								◆

Design of Experiment; cases for initial CFD simulations and calibration tests

Test #	R-32 charge [kg]	Leak time [min]	Leak rate [g/s]	Leak orifice size* [m ²]	Presence of obstacles	Leak location (x, y, z) [all in m]	Remarks	Leak volumetric flow rate [SLPM]
1	3.257	4	13.572	0.093	None	(0, 1.83, 1.8)	Baseline case	378.214
2	4.886	4	20.358	0.093	None	(0, 1.83, 1.8)	1.5 x higher charge	567.322
3	6.515	4	27.144	0.093	None	(0, 1.83, 1.8)	2.0 x higher charge	756.429
4	3.257	1	54.289	0.093	None	(0, 1.83, 1.8)	1 min fast release	1512.858
5	3.257	10	5.429	0.093	None	(0, 1.83, 1.8)	10 min slow release	151.286
6	2.172	4	9.048	0.093	None	(0, 1.83, 1.2)	Different leak height	252.143
7	1.842	4	7.675	0.093	None	(0, 1.83, 0.6)	Different leak height	213.878
8	3.257	4	13.572	0.093	None	(0, 1.83, 1.8)	Liquid leak	378.214
9	3.257	4	13.572	0.093	Boxes	(0, 1.83, 1.8)	10% occupied	378.214
10	3.257	4	13.572	0.093	Boxes	(0, 1.83, 1.8)	25% occupied	378.214
11	6.515	4	27.144	0.093	None	(0, 1.83, 1.8)	Constant ventilation	756.429
12	6.515	4	27.144	0.093	None	(0, 1.83, 1.8)	Start ventilation at 10% LFL	756.429

Initial Simulations & Calibration Testing

- Simulations and testing based on identical room foot print area and volume
 - Parameters as listed on previous slide
- Simulation assumed relatively large release area
 - Yields waterfall like refrigerant flow into room with pooling at floor level & high concentration gradient (right, middle →)
 - Leak release set up for tests intended to match assumed flow pattern (right, bottom →)
- Simulation results did not match test results very well
 - More details in Part 1 report: <https://www.osti.gov/biblio/1460212>

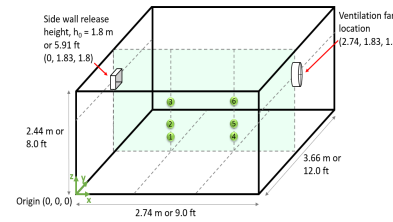

Sim. room geometry

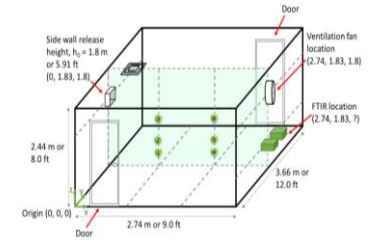

Test room geometry

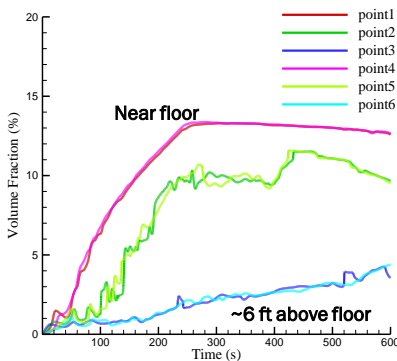

Initial sim. results, Case 1, baseline
Max conc. ~14% at floor

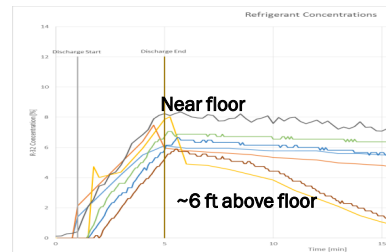

Test results, Case 1, baseline
Max conc. ~8% at floor & 6 ft. level
just after leak ends

Assumed release flow pattern

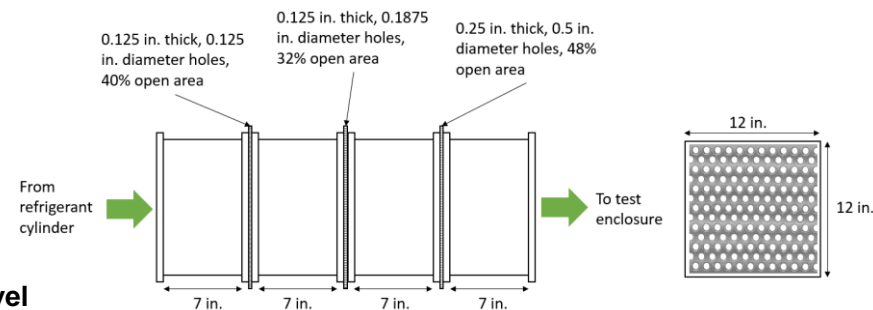
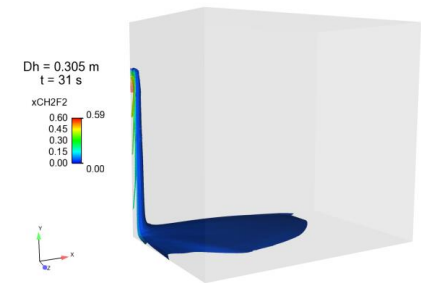

Leak release set up for calibration tests; intended to mimic release through coil and grill of room AC