

Adaptive Weather Resistant Barrier for Building Envelopes to Control Moisture Ingression and Increase Energy Efficiency

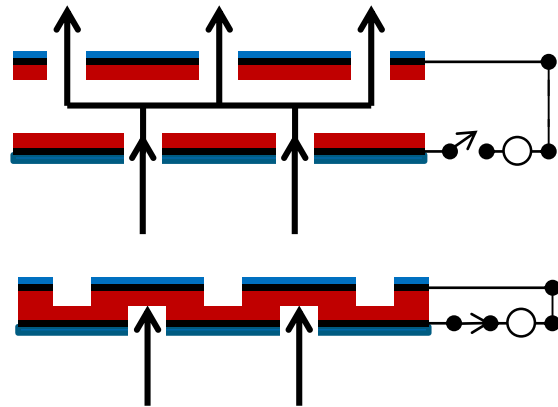

EA Membranes LLC

Joseph Trentacosta, PI, Managing Partner

302-545-2496 jtrentacosta@eamembranes.com

Project Summary

Timeline:

Start date: July 2, 2018

Planned end date: June 3, 2018 (w/NCE)

Key Milestones

1. Complete hygrothermal modeling to demonstrate benefit of technology – Completed 10/2018
2. Assemble and Test 4' X 8' Prototype(s) to demonstrate technology at building scale – In progress; Completion 5/2019

Budget:

Total Project \$ to Date:

- DOE: \$135,154
- Cost Share: \$0

Total Project \$:

- DOE: \$150,000
- Cost Share: \$0

Key Partners:

Oak Ridge National Laboratory
DowDuPont
Electrostatic Applications
Accudyne Systems, Inc
Preco, Inc

Project Outcome:

Develop and commercialize an adaptive weather resistant barrier (WRB) to improve control of water vapor transport into and out of residential and commercial building enclosures for reduced mold growth risk and improved energy usage.

Team



EA Membranes LLC

EA Membranes LLC was formed in 2016 upon acquisition of adaptive, electrostatically actuated membrane (EAM) IP and technology from DuPont. The **three** equal share partners, two of whom invented the EAM technology, have over 90 combined years of R&D and business development experience in materials and innovative systems development.



Joe Trentacosta
PI, Managing Partner



Vivek Kapur



Kurt Adams



Provides expertise in building science to the team and, in particular, completed hygrothermal modeling to validate the product concept



Provides consultation to the team in building materials technology and an understanding of market forces influencing product development



Provides CAD & fabrication services



Provides laser cutting & contract manufacturing

Challenge

- Controlling water content in the wall cavity of residential and commercial buildings is considered critical for
 - Reducing mold growth risk
 - Eliminating rot
 - Reducing latent heat load on HVAC



- Current Weather Resistant Barriers (WRB)*
 - Single, static permeance either high or low to control moisture ingress/egression
 - High permeance WRBs facilitate high moisture egression when the wall cavity is wet to allow drying but do not prevent excessive moisture ingress
 - Low permeance WRBs resist moisture ingress but can prevent drying when the wall cavity becomes wet.

** aka - water resistant barriers*

Mechanisms of Moisture Transport into Building Envelopes

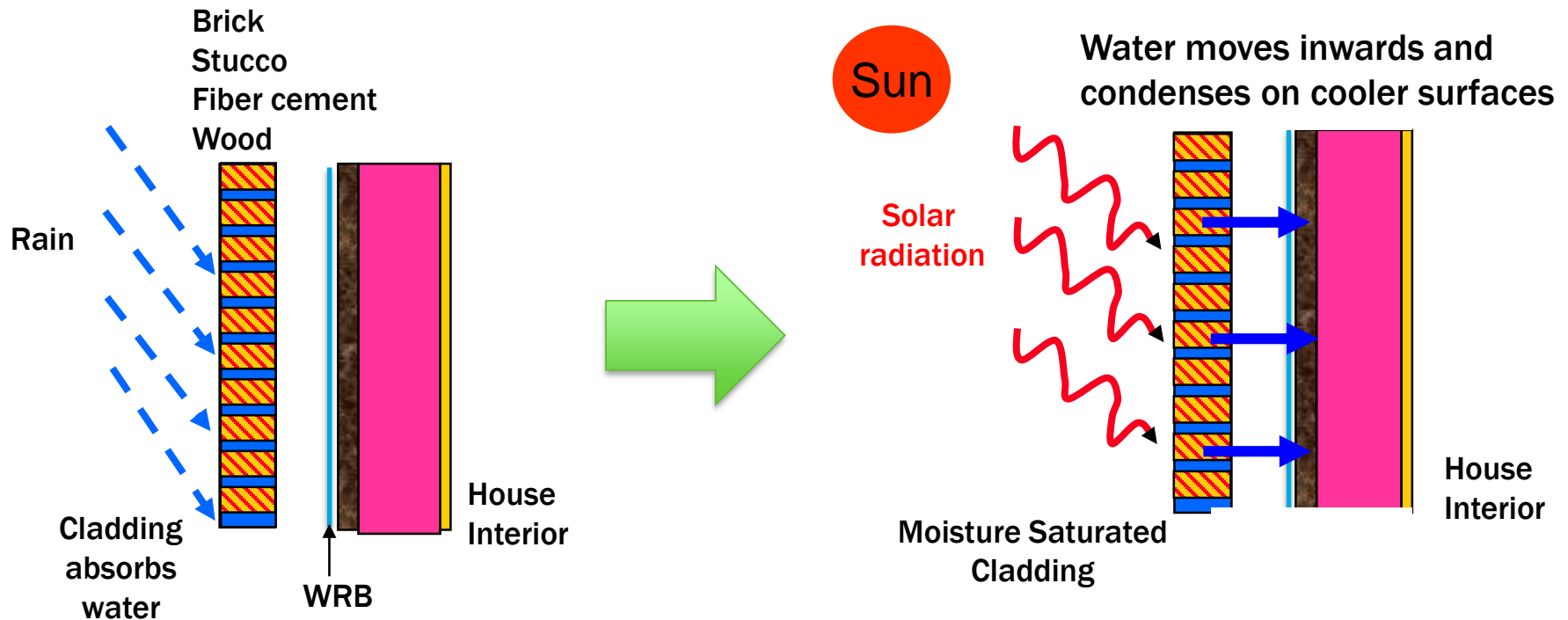

- Exterior cladding soaks up water from precipitation
- Solar radiation forces water vapor to ingress further into building cavity
- Water vapor condenses and collects in cooler regions of the cavity
- Leads to mold growth and eventual rot and decay in the wall cavity

Approach

- EA Membranes LLC is developing a dual permeance WRB based on our patented Electrostatically Actuated Membrane (EAM) technology.
 - Unactuated open state: high permeance to facilitate moisture egression when wall cavity has high water content
 - Actuated closed state: low permeance to resist water ingress when outside humidity is high
 - Sensors detect humidity in wall cavity and ambient conditions

Electrostatically Actuated Membrane Technology

- Two membranes (1-2 mil)
- Each with same array of holes
- Array in one membrane out of registration with second membrane
- Membranes separated by a spacer (5-10 mil)
- Conductive layer incorporated in both membranes; layers connected through high voltage power supply (500-1000 VDC)

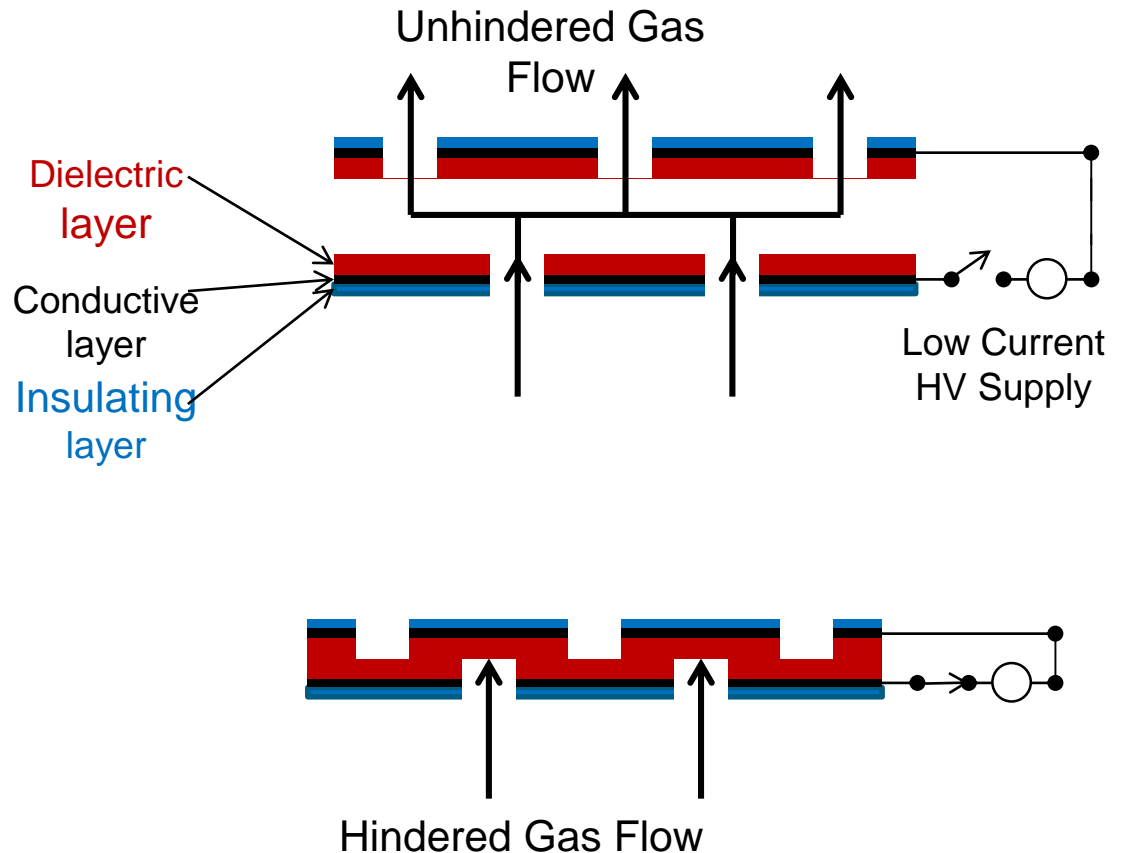

Simple Example of EAM

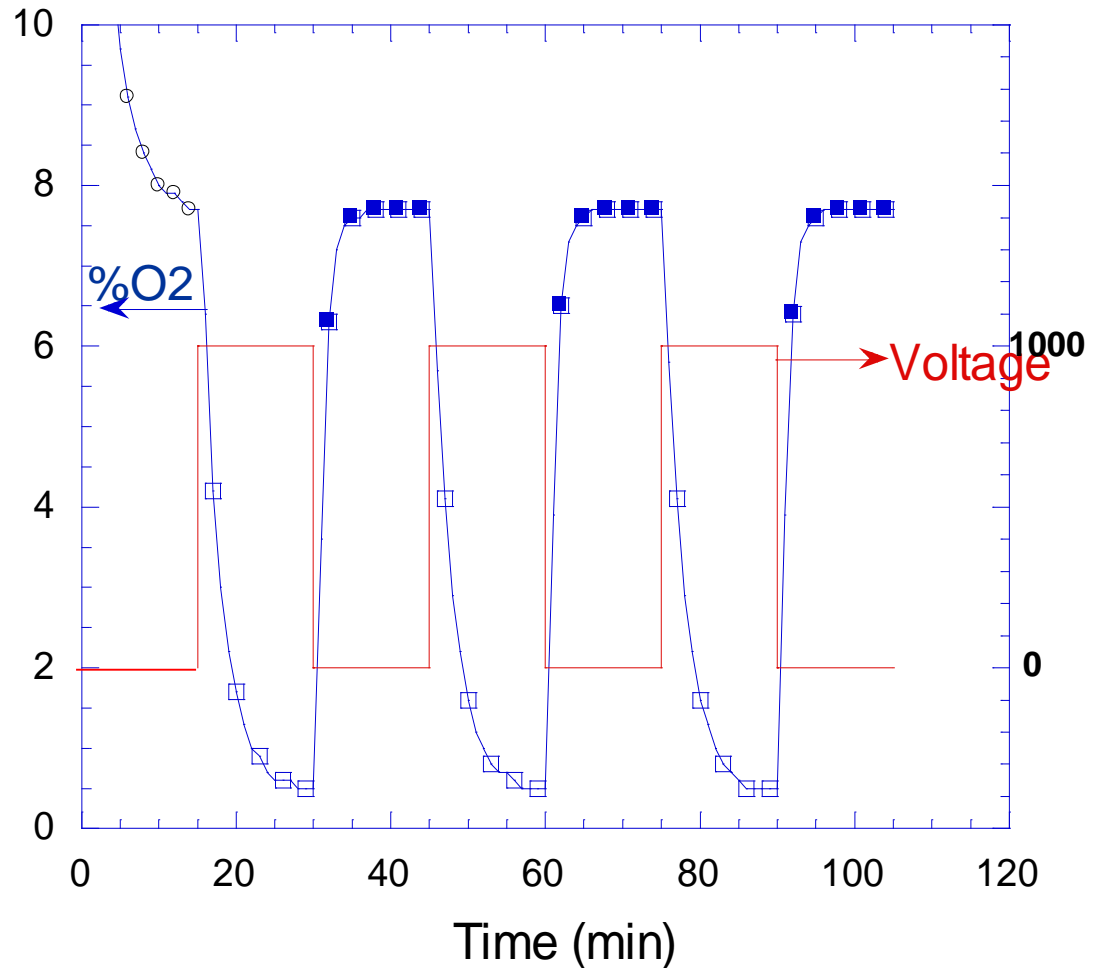
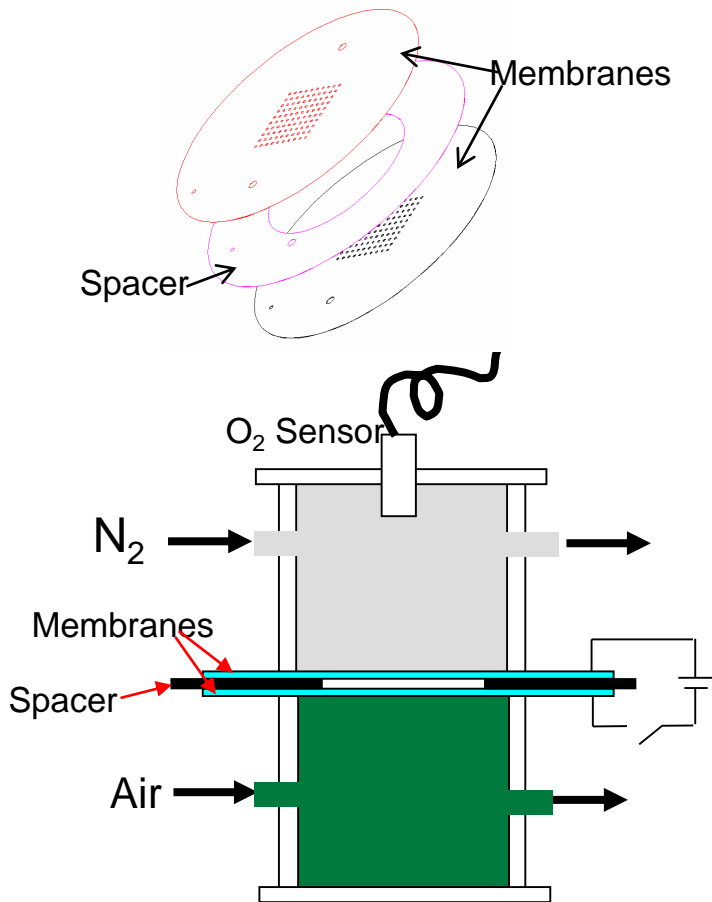

Adaptive EAM WRB Changes Permeability on Demand

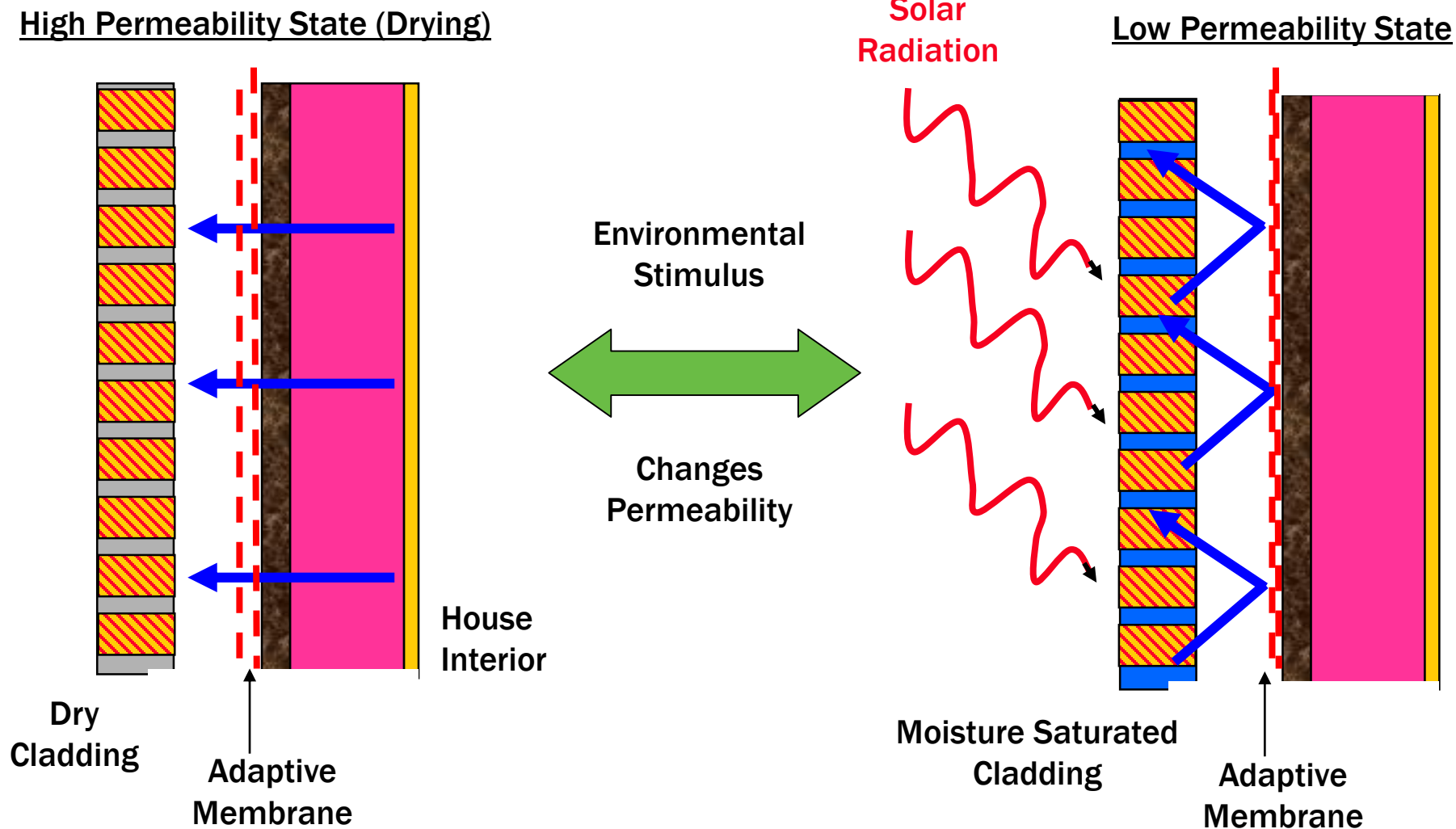

Impact

- Current WRBs provide a single permeance selected to either keep moisture out of the wall cavity or permit drying of the wall cavity
- EA Membranes provides a WRB with two permeance levels 50 to 100 X apart to both keep moisture out of the wall cavity and permit drying of the wall cavity

Product	Manufacturer	Perm Rating
Asphalt Impregnated Felt		2
Weathermate™	DowDuPont	5
WeatherSmart™	Fotifiber	8
GreenGuard®	Kingspan	10
Typar	Reemay Berry	12
Hydrogap®	Benjamin Opdyke	12
Pinkwrap®	Owens Corning	14
Commercial Wrap	DowDupont	25
Homewrap®	DowDuPont	55
R-Wrap®	Ludlow CP	59

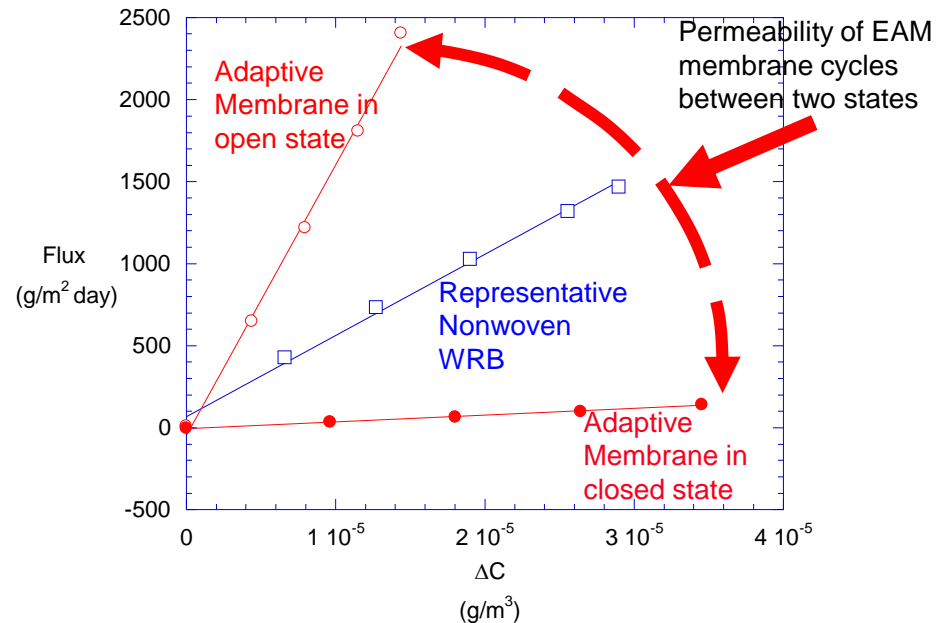

Progress

- Hygrothermal modeling comparing dual permeance and single permeance WRB completed
 - Dual permeance WRB effective in reducing mold growth risk
 - No impact on energy usage
- Subscale EAM membrane testing completed
 - Demonstrated achievement of target permeance levels
- 4' X 8' EAM WRB prototype in development
 - Membrane fabrication and 4' X 8' panel assembly process demonstrated
 - One prototype assembled and tested. Second unit in assembly
- Identified critical technology to obviate spark/shock hazards
 - Use resistive coatings vs. metalized coatings
 - Initial demonstration underway

Hygrothermal Modeling

ORNL – Florian Antretter, André Desjarlais, Diana Hun

- **WUFI® software used**
 - Approach for realistic modeling of dual perm WRB developed & implemented
 - VTT postprocessor for mold growth assessment
- **21 Cases studied including**
 - Dual and single perm WRB
 - 3 open state perm levels for dual system
 - 5 Climate Zones
 - Gypsum & OSB sheathing
 - Switching for dual system based on RH at sheathing
- **Key conclusions**
 - Dual perm WRB reduces mold growth risk in all climate zones modeled
 - Effect greater with gypsum sheathing
 - Preferred open state perm level >20
 - Dual perm WRB has no impact on overall energy usage.

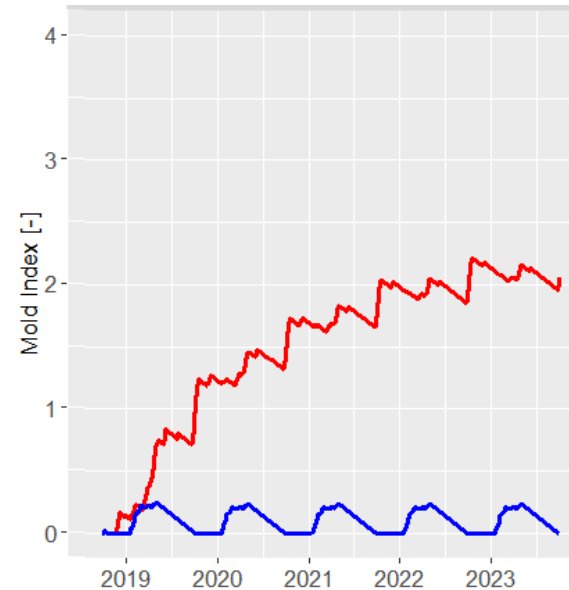

Typical result - modeled mold index at inner surface of sheathing vs time for Chicago climate zone with gypsum sheathing

red=single perm WRB

blue=dual perm WRB

Subscale Testing of EAM WRB Array Designs

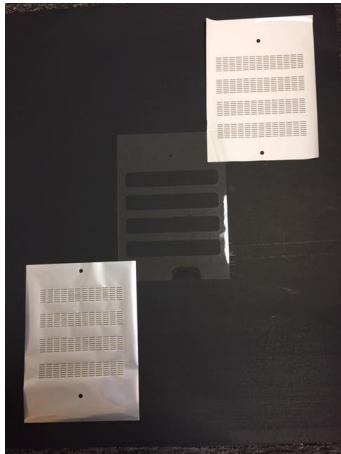

Subscale EAM Membrane Set

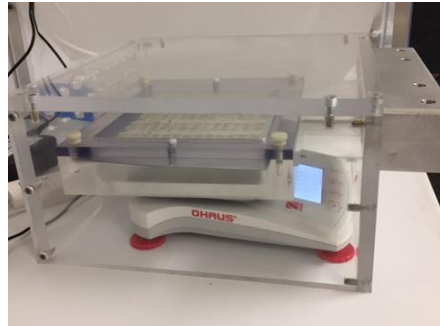

Custom-designed tester
Adaptation of ASTM E96
for EAM

Item	Perms
EAM High Perm Design, open state	53
EAM Low Perm Design, open state	26
Tyvek® Homewrap	42
Tyvek® Commercial	23
Dow Weathermate Plus®	10

Results - EAM Open State Permeance vs. Controls

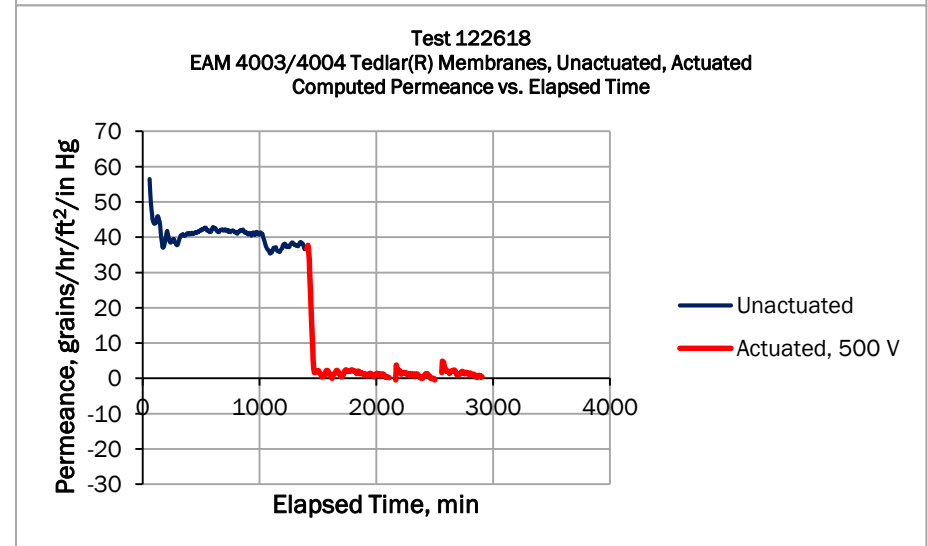
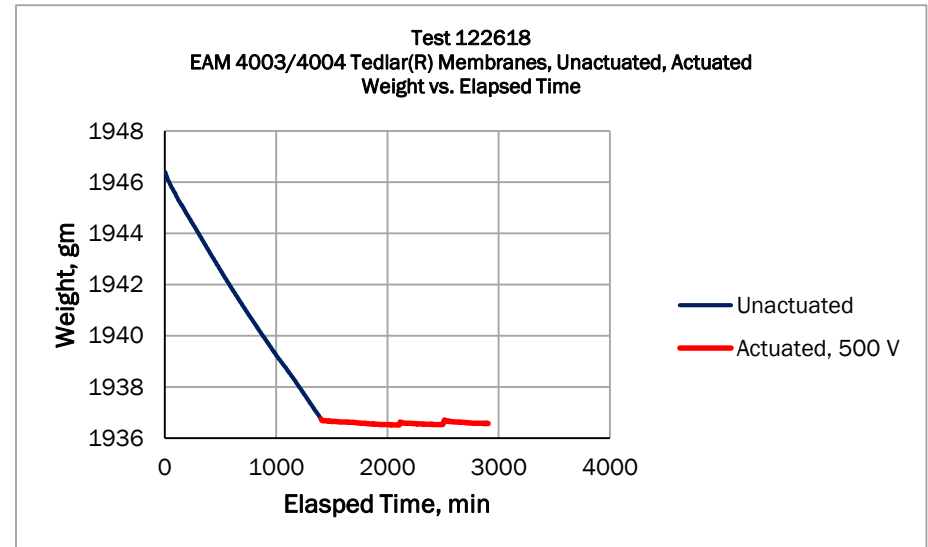

Typical Test Results, Open and Closed State EAM

Prototype Development and Testing

Prototype Design

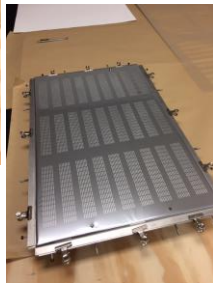
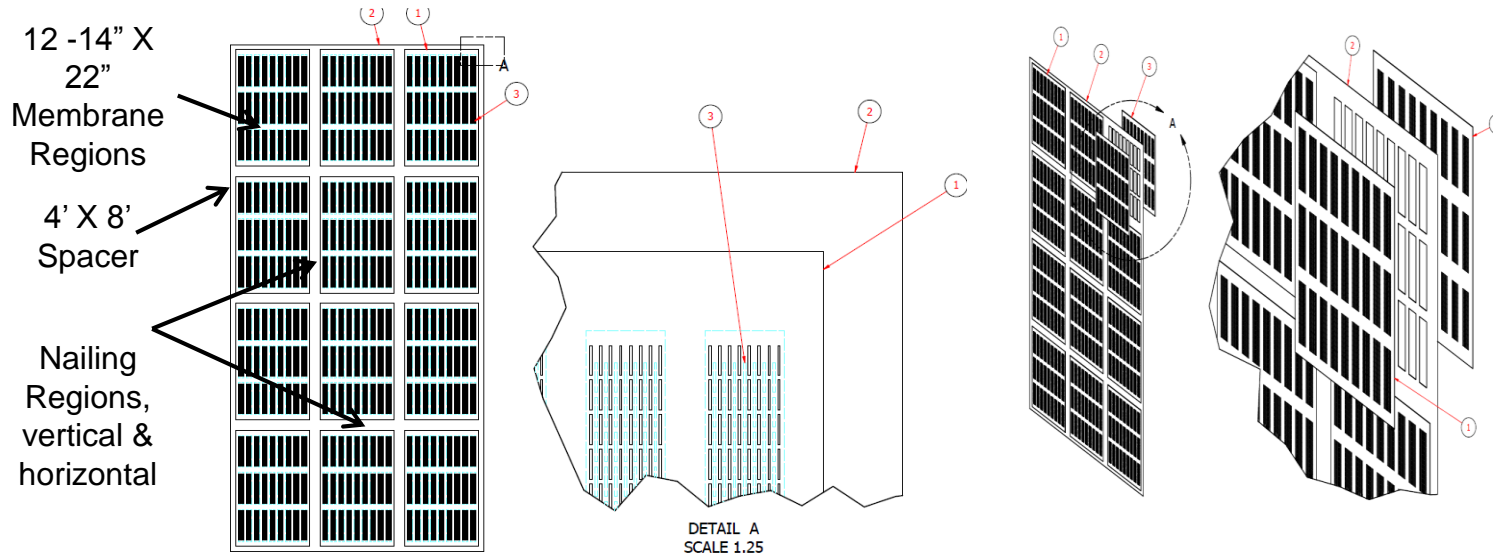

Assembly Process Developed



First Prototype



Prototype Test System

Stakeholder Engagement

- **Technical expert from major building materials manufacturer is member of current SBIR Phase 1 team as consultant**
- **Presented technology and current program to building materials innovators at two major building materials manufacturers to solicit feedback and support**
- **With ORNL partners will present paper “Adaptive Water Resistant Barrier for Building Envelopes” at ASHRAE Buildings XIV International Conference 12/2019**

Remaining Project Work

- **Current SBIR Phase 1 (NCE 6/3/19)**
 - Complete demonstration of 4' X 8' prototypes
 - Complete initial demonstration of resistive coating in place of metalized coatings
- **Next Steps (next 6 months)**
 - Validate Market Interest
 - Two major building materials manufacturers believe technology would solve major issue in building envelope technology but we need to complete
 - Cost of manufacturing analysis
 - Installation cost analysis
- **Next Steps (next 2 years)**
 - Partner with building materials manufacturer
 - Develop plan for market development testing
 - Complete technical development
 - Primarily electrical and control system for entire structure
 - Scaled up prototype fabrication
 - Instrumented wall testing
 - Develop commercial process

Thank You

EA Membranes LLC
Joe Trentacosta, PI, Managing Partner
302-545-2496 jtrentacosta@eamembranes.com

REFERENCE SLIDES

Project Budget

Project Budget: DOE SBIR Phase 1 Funding \$150,000

Variances: none

Cost to Date: \$135,154 expended to date

Additional Funding: none

Budget History

7/2/2018– FY 2018 (past)		FY 2019 (current)		FY 2020 (planned)	
DOE	Cost-share	DOE	Cost-share	DOE	Cost-share
\$100,072	\$0	\$35,082	\$0		

Project Plan and Schedule

Task	2018		2019				2020			
	Q3	Q4	Q1	Q2	Q3	Q4	Q1	Q2	Q3	Q4
SRIR Phase 1 Program										
Hygrothermal Modeling		◆								
Electrostatic Modeling		◆								
Subscale Testing	◆									
Des/Fab/Test 4X8 Prototype	◆									
Future Work										
COM & Installation Cost Analysis										
Partner w/Building Mts Mfr						◆				
Envelope Electrical System Dev										
Scaled-Up Prototype Fab										
Begin Instr Wall Testing										◆