



**U.S., Department of Energy (DOE)
Bioenergy Technologies Office (BETO)
2019 Project Peer Review**

**Improved Hydrogen Utilization and Carbon Recovery for
Higher Efficiency Thermochemical Bio-oil Pathways
(WBS 2.5.4.405)**

March 5, 2019

Advanced Development & Optimization (ADO)

David C. Dayton, PI

RTI International

This presentation does not contain any proprietary, confidential, or otherwise restricted information

Goal Statement

Improve hydrogen utilization and carbon recovery in a novel, enabling technology that combines the best of several direct biomass liquefaction technologies.

1. Increase hydrogen utilization for hydrodeoxygenation during *in-situ* catalytic biomass pyrolysis to maximize the carbon and energy recovery in a low oxygen content, thermally stable bio-crude intermediate that can be upgraded into a finished biofuel.
2. Improve the carbon efficiency of the integrated process by converting carbon in aqueous stream to methane for hydrogen production.
3. Improve water quality to reduce fresh water consumption and reduce wastewater treatment costs.

Target: nth plant modeled MFSP of \$3/GGE (2014\$) via RCFP with hydroprocessing to produce hydrocarbon biofuel with GHG emissions reduction of 50% or more compared to petroleum-derived fuel.

Key Project Milestones

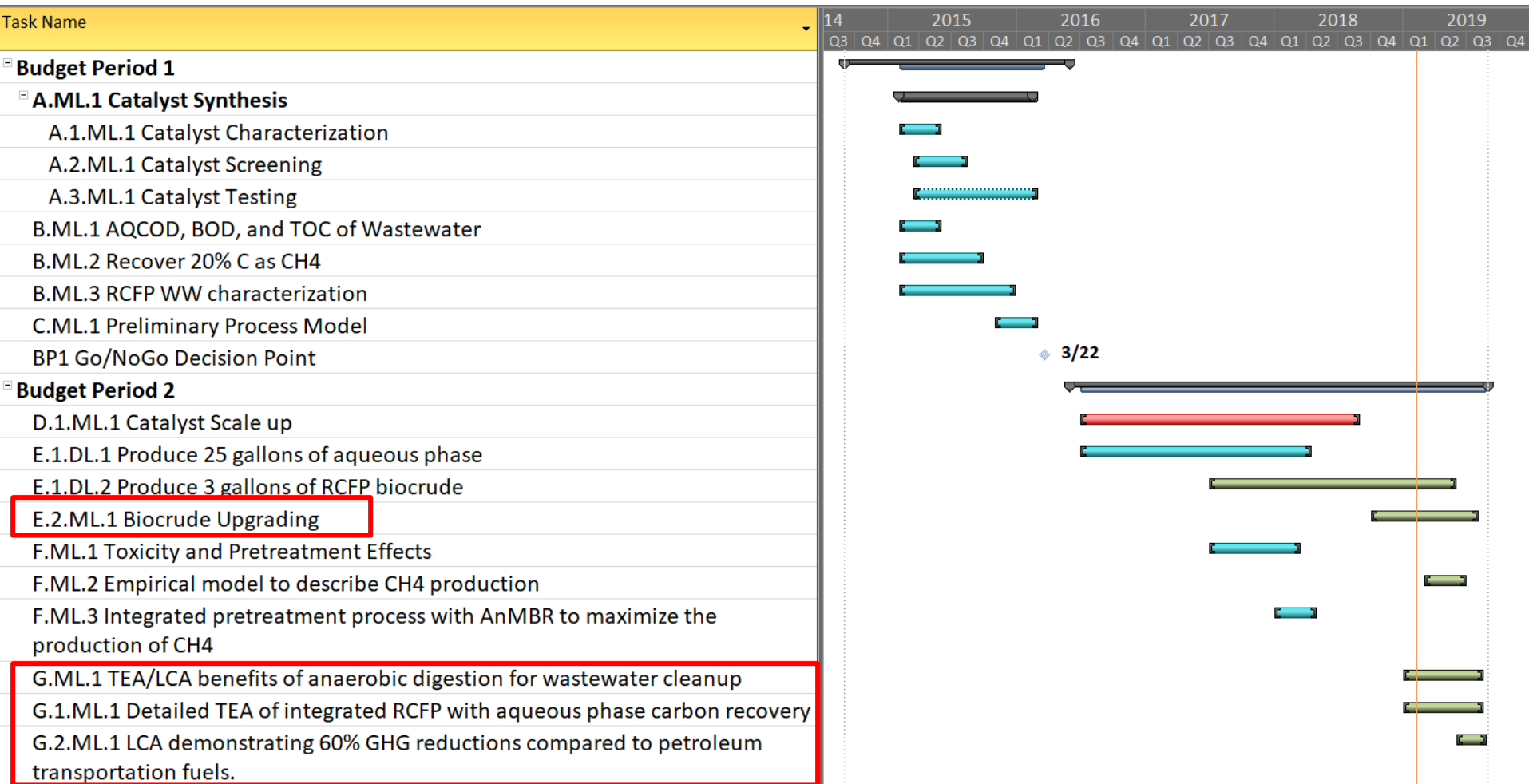

Project Budget Table (actuals through Dec 2018)

Budget Periods	Original Project Cost (Estimated)		Project Spending and Balance	
	DOE Funding	Project Team Cost Shared Funding	Spending to Date	Remaining Balance
BP1				\$0
Task 1: Catalyst Development	\$561,819	\$140,455	\$702,274	\$0
Task 2: Aqueous Phase Carbon Recovery	\$432,581	\$108,145	\$540,726	\$0
Task 3: Preliminary Process Design and Integration	\$25,481	\$6,370	\$31,851	\$0
BP2				\$984,194
Task 4: Catalyst Screening and Scaleup	\$330,320	\$82,580	\$412,900	\$232,255
Task 5: Process Development	\$401,126	\$100,281	\$501,407	\$375,818
Task 6: Aqueous Phase Carbon Conversion Process Development	\$389,092	\$97,273	\$424,684	\$209,423
Task 7: Process Modeling and TEA	\$10,278	\$2570	\$12,848	\$86,104
Task 8: Project Management	\$202,699	\$50,675	\$217,521	\$80,594

Quad Chart Overview

Timeline

- Contract award date: 9/1/2014
- Project kick-off: 01/29/2015
- Budget Period 1 end date: 5/31/2016
- Budget Period 2 approved: 10/14/2016
- Project end date: 8/31/2019

Barriers

- Ct-F. Efficient High-Temperature Destruction to Intermediates
- Ct-H. Efficient Catalytic Upgrading of Bio-Oil Intermediates to Fuels and Chemicals
- Ct-L. Aqueous Phase Utilization and Wastewater Treatment

Partners

- RTI International – project lead, RCFP technology development, catalyst development, water treatment technology testing, process modeling, project management
- Haldor Topsøe A/S (HTAS) – Catalyst development and upgrading consultant
- Veolia Water Technologies, Inc. – Aqueous carbon recovery and water treatment technologies consultants

	Pre-FY17 Costs	FY17 Costs	FY18 Costs	FY19 - Project End Date Costs
DOE Funded	\$1,138,270	\$400,455	\$512,357	\$1,089,444
Cost Share - Veolia	\$0	\$0	\$0	\$50,000
Cost Share - Haldor Topsoe	\$0	\$0	\$0	\$86,465
Cost Share - State of NC	\$266,437	\$279,427	\$0	\$103,034
Total	\$1,404,707	\$679,882	\$512,357	\$1,328,943

1- Project Overview

- DE-FOA-0000812 - February 2013 : Carbon, Hydrogen, and Separation Efficiencies in Bio-Oil Conversion Pathways (CHASE Bio-Oil Pathways)
- 36 month original PoP; 2 NCEs to account for delay in project start and BP1/BP2 continuation application approval delay and change in approach due to safety considerations for hydrogen addition to pilot plant

High-level Objectives:

- Develop 2nd generation catalysts to enhance hydrodeoxygenation during biomass pyrolysis at ambient pressure
- Integrate wastewater treatment technology to recover aqueous phase organics to recycle hydrocarbons and produce methane that can be re-used to produce hydrogen for bio-crude production and upgrading.

Modified Approach:

Pilot-scale biocrude production was deemed impractical for several reasons:

1. Safety considerations for hydrogen addition to 1 TPD unit
2. High hydrogen concentration required for effective HDO
3. Kinetic mis-match for regenerating and reducing the catalyst continuously in the 1TPD pilot plant

Biocrude production (3 gallons) for upgrading will be performed in laboratory reactor

Challenge: Biofuel Yield and Carbon Efficiency

Improve Biofuel Yield and Carbon Efficiency

- Improve catalyst performance and optimize process conditions
 - Enhance HDO during biomass pyrolysis at low severity process conditions
- Aqueous phase carbon recovery
 - Integrate wastewater treatment technology to recover aqueous phase organic compounds to recycle hydrocarbons

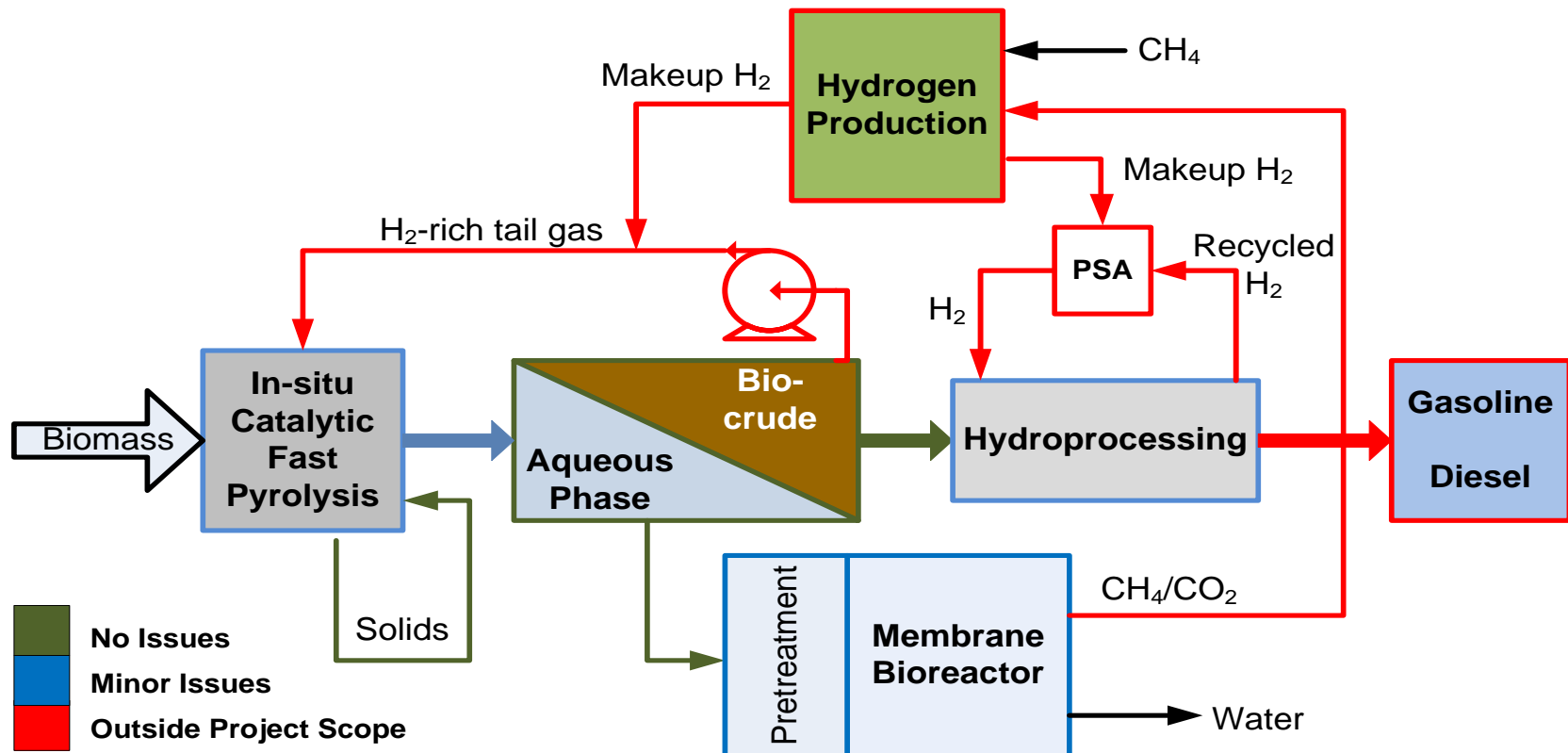

2 – Approach (Technical) Improving hydrogen utilization

Screening at multiple scales to identify catalysts that maximize biocrude yield and minimize biocrude oxygen content:

- Fundamental micro-pyrolyzer studies to study HDO as a function of catalyst and process conditions with real biomass
- Automated catalyst screening with model compounds to understand fundamental HDO chemistry and reaction schemes
- Laboratory-scale fluidized bed studies to investigate material balances and bio-crude properties as a function of catalyst and process conditions
- Bio-crude production for process optimization and upgrading studies

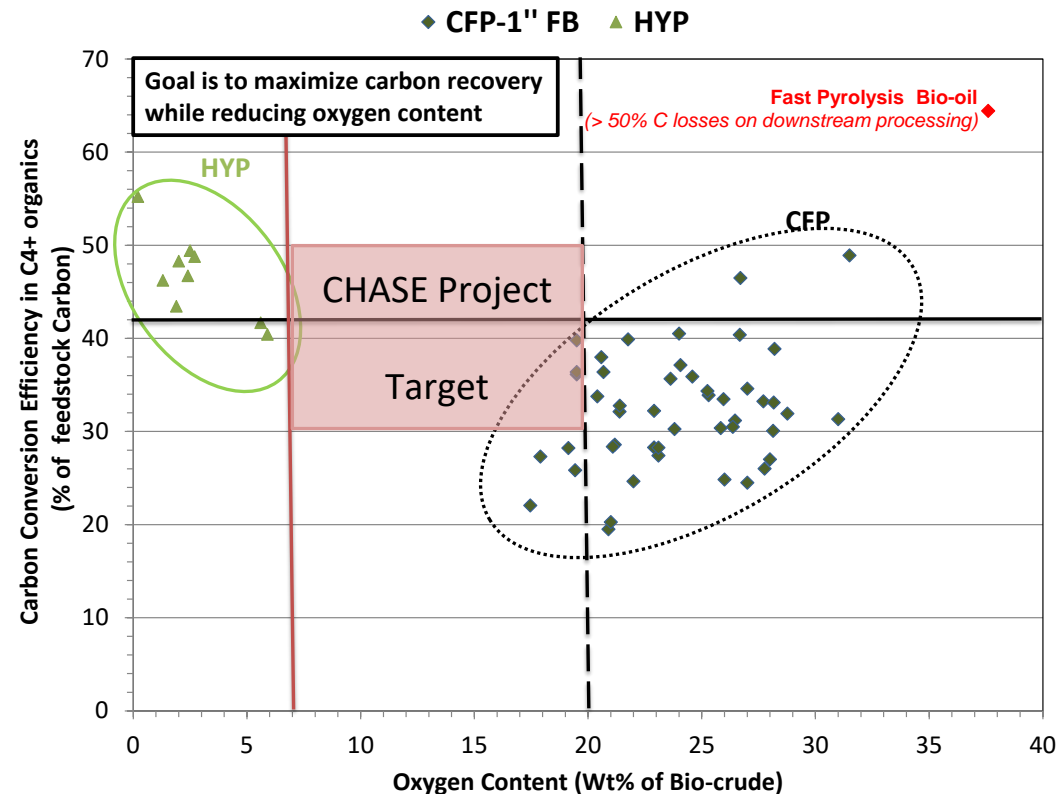
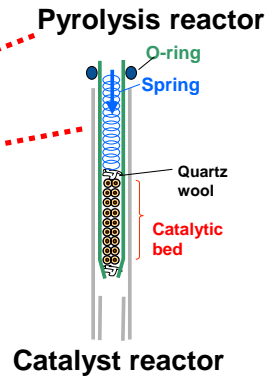
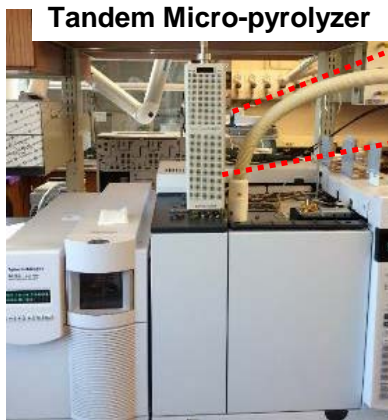

2 – Approach (Technical) Improving carbon efficiency

Determine the technical feasibility of biologically converting carbon in the aqueous phase to methane using anaerobic digestion coupled with membrane distillation.

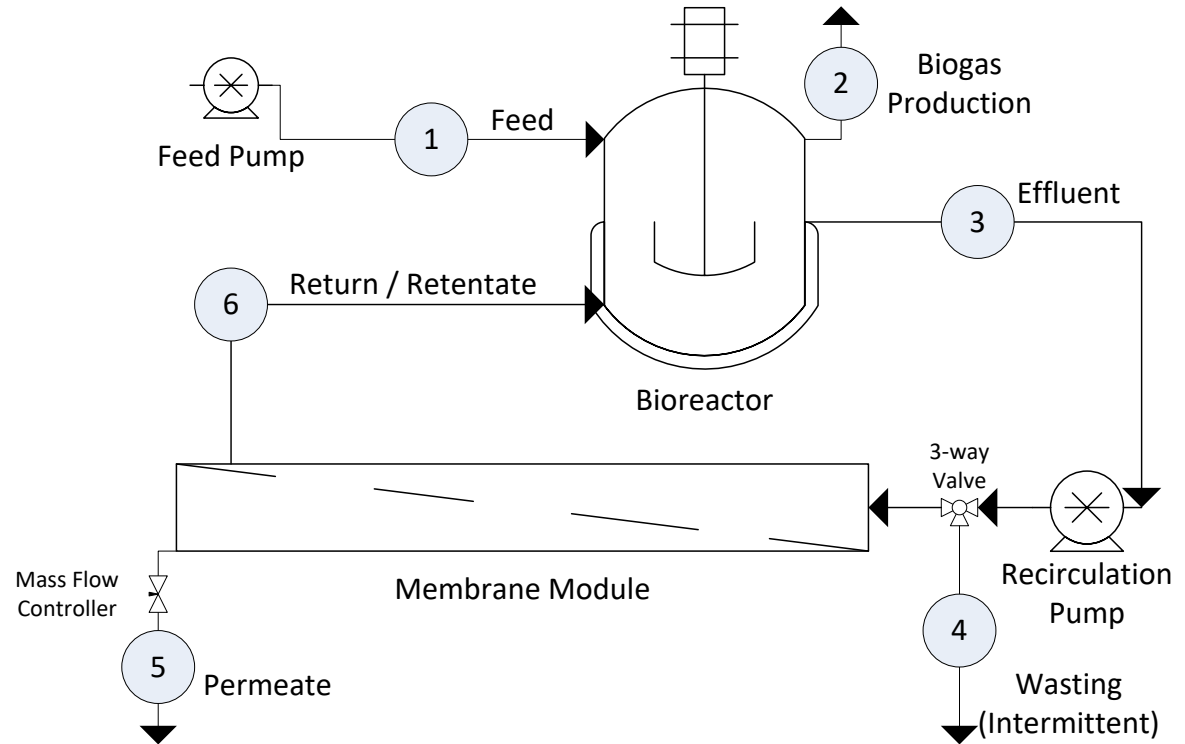

- Test aqueous phase samples for methane potential and toxicity with regards to digestion in bioreactors based on industry relevant test protocols
- Provide a preliminary assessment of treatment needs of water effluent from thermochemical biomass conversion processes and suggest treatment technology options

2 – Approach (Management) BP1 Laboratory-scale Evaluations

Detailed project plan with quarterly milestones and deliverables and Go/NoGo decision point between budget periods

Task 1.0: Catalyst Development (RTI, Haldor Topsoe)

Subtask 1.1: Catalyst Synthesis and Characterization

Subtask 1.2: Catalyst Screening

Subtask 1.3: Catalyst Testing

Task 2.0 Aqueous Phase Carbon Recovery Proof-of-Concept (RTI, Veolia)

Task 3.0: Preliminary Process Design and Integration (RTI, Haldor Topsoe, Veolia)

Go/No-Go Decision Point: Correlate catalyst characteristics with HDO activity and coke formation rates measured in 1) model compound experiments and 2) validated with CFP data collected in a 2" FBR system. In parallel, evaluate pretreatment strategies and methane potential of aqueous phase carbon recovery in AnMBR.

- Demonstrate production of bio-crude with less than 8 wt% oxygen
- Greater than 42% of the carbon input from biomass will be recovered in the bio-crude
- Quantify methane produced from AnMBR treatment of the aqueous phase and recover 20% of the carbon as methane
- Estimate advanced biofuel production cost for integrated process and preliminary GHG emissions reduction potential

Task 8.0: Project Management and Reporting

2 – Approach (Management) BP2 Scale-up and Process Development

Task 4.0: Catalyst Screening (RTI, Haldor Topsoe)

Subtask 4.1: Catalyst Scale-up

Key milestone: Obtain fluidizable catalyst for 1TPD biomass pyrolysis unit based on catalyst screening efforts in BP1 and BP2

Task 5.0: RCFP Process Development (RTI, Haldor Topsoe)

Subtask 5.1: RCFP Bio-crude Production

Subtask 5.2: RCFP Bio-crude Upgrading

Key deliverables: Produce at least 25 gallons of aqueous phase for bioreactor studies and 10 gallons of bio-crude for upgrading

Task 6.0 Anaerobic Membrane Bioreactors (AnMBR) for Converting Aqueous Phase Carbon to Methane (RTI, Veolia)

Key Milestones: Develop an empirical model to describe methane production from aqueous phase; Demonstrate the potential of an integrated pretreatment process for AnMBR and estimate capital and operating costs

Task 7.0: Process Modeling and Techno-economic Analysis (RTI, Haldor Topsoe, Veolia)

Key Milestone: TEA/LCA benefits of AD for aqueous phase carbon recovery compared to alternative wastewater treatment options

Subtask 7.1 Process Modeling

Subtask 7.2 Life-Cycle Assessment

Task 8.0: Project Management and Reporting (RTI)

3 – Technical Accomplishments/Progress/Results

Catalyst Development Summary (BP1)

- Consistent results from micropyrolyzer, model compound reactor, and fluidized bed reactor
- Commercially available Mo-based catalyst had the best deoxygenation efficiency (**7.4 wt% O**) with the highest **C₄⁺ yield (43.0 mole %C)**

RCFP Bio-crude Production (BP2)

- 2-L of RCFP bio-crude delivered to Haldor Topsoe for co-processing studies
- 3-L (target 10-L) of RCFP bio-crude produced to date for RTI upgrading studies

RCFP Bio-crude Co-processing with Light GasOil (BP2)

- Test ran for > 1000 hours without shut-down or severe deactivation
- 99.97% oxygen removal by HDO
- 89 wt% of RCFP bio-crude converted to hydrocarbons

Anaerobic Digestion of Aqueous Phase (BP1/BP2)

- AnMBR converts 70% of the aqueous phase carbon into methane: 365 L CH₄/kg COD.
- Aqueous phase percentage has increased 150-fold during the project as the microbial community has adapted.
 - Starting concentration was 0.02% with non-acclimated microorganisms
 - Currently 3% with acclimated organisms with plans to increase to > 5%.
- Increasing RCFP aqueous phase concentration significantly reduces the overall capital cost of the wastewater treatment plant

Preliminary TEA and LCA (BP2)

- Updated CFP process model for hydrogen addition and recycle
- Advanced biofuel production cost: \$4.31 gge (current state of technology)
- GHG reduction: 76.4%-97.7% (depending on process hydrogen use)

Process Development and Biocrude Production



- 2.5" fluidized bed reactor with 4" disengagement zone
- Biomass feeding rate: 2-5 g/min
- Liquid collection: 3 condensers and 1 ESP
- Non-condensable gases analyzed by micro GC
- Liquid product analyzed by Karl Fischer titration, elemental analysis, GC/MS, etc..

Catalyst Screening

■ organic liquid ■ C₄-C₆ ◆ O (wt%) ▲ Hydrogen consumption (wt%)

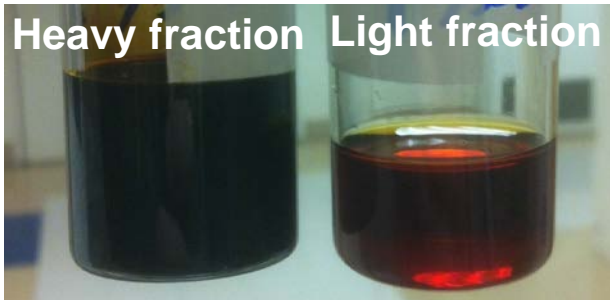
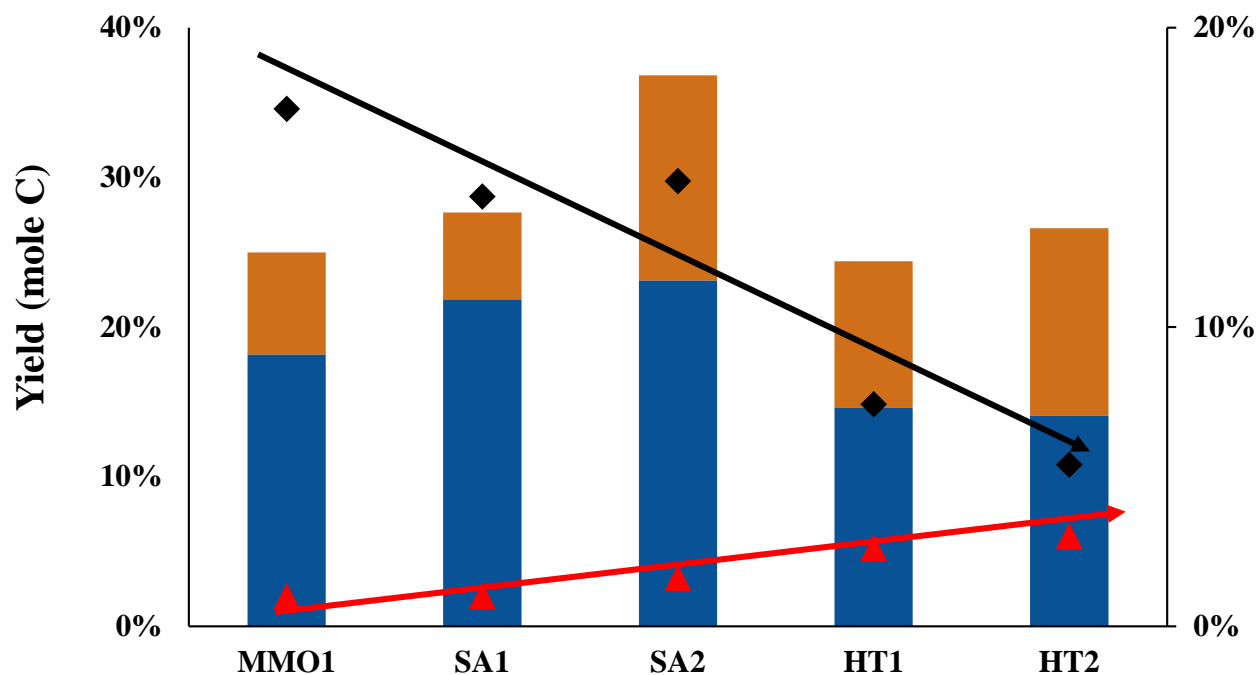

Influence of Process Conditions

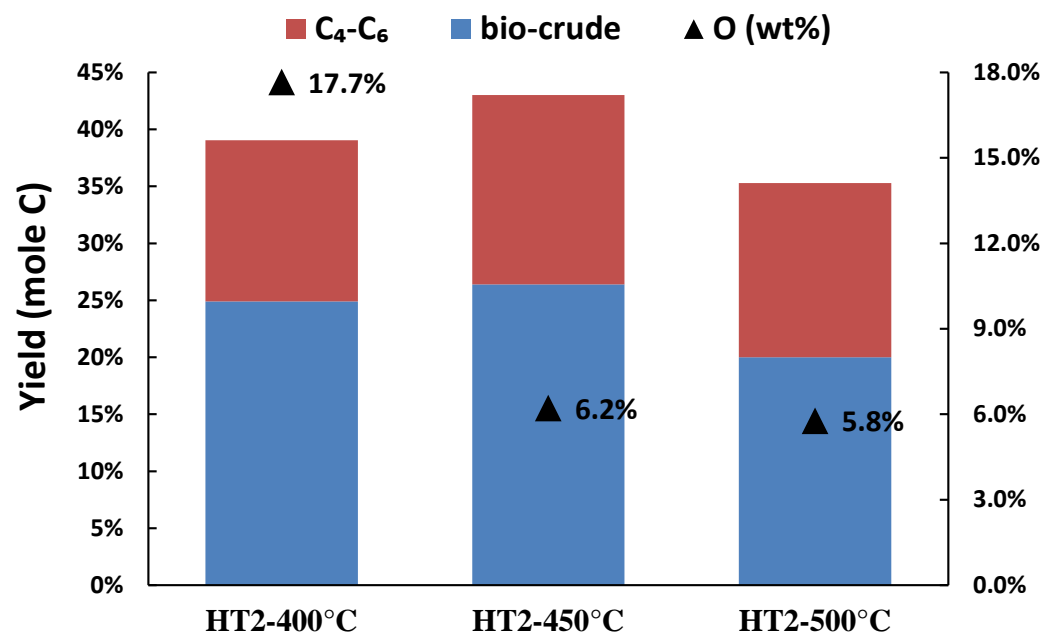

High temperature (500°C)
 Lower solids yield and higher gas yield

- More light gases, especially methane, indicates over-cracking
- Lower C₄⁺ organics yield

450°C seems optimal for maximizing deoxygenation and minimizing cracking

Higher hydrogen concentration seems to inhibit coking and increase organic liquid yield while decreasing bio-crude oxygen content

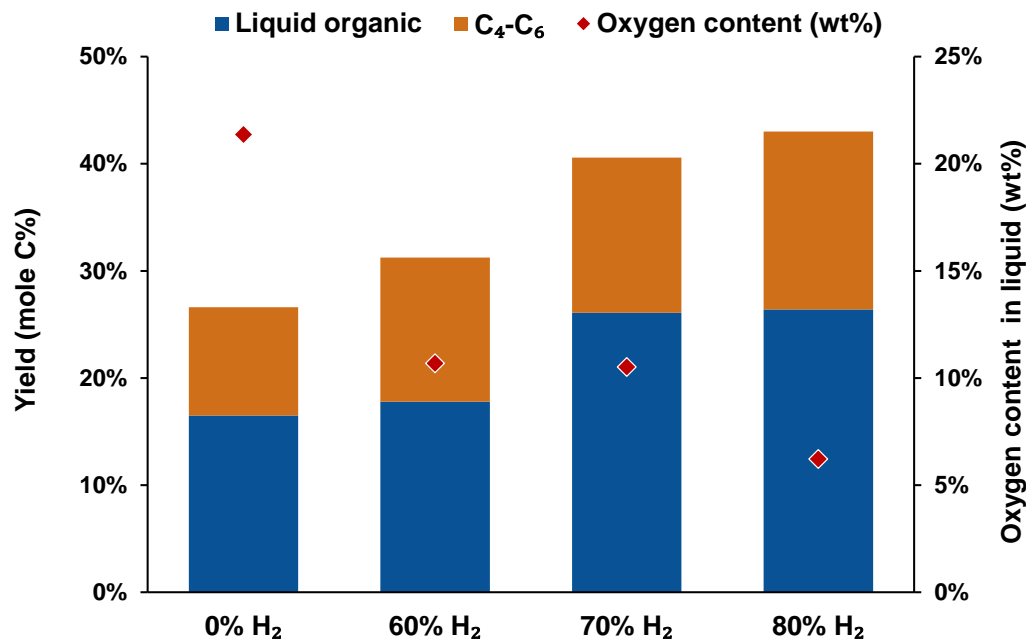

RCFP Biocrude Production Summary

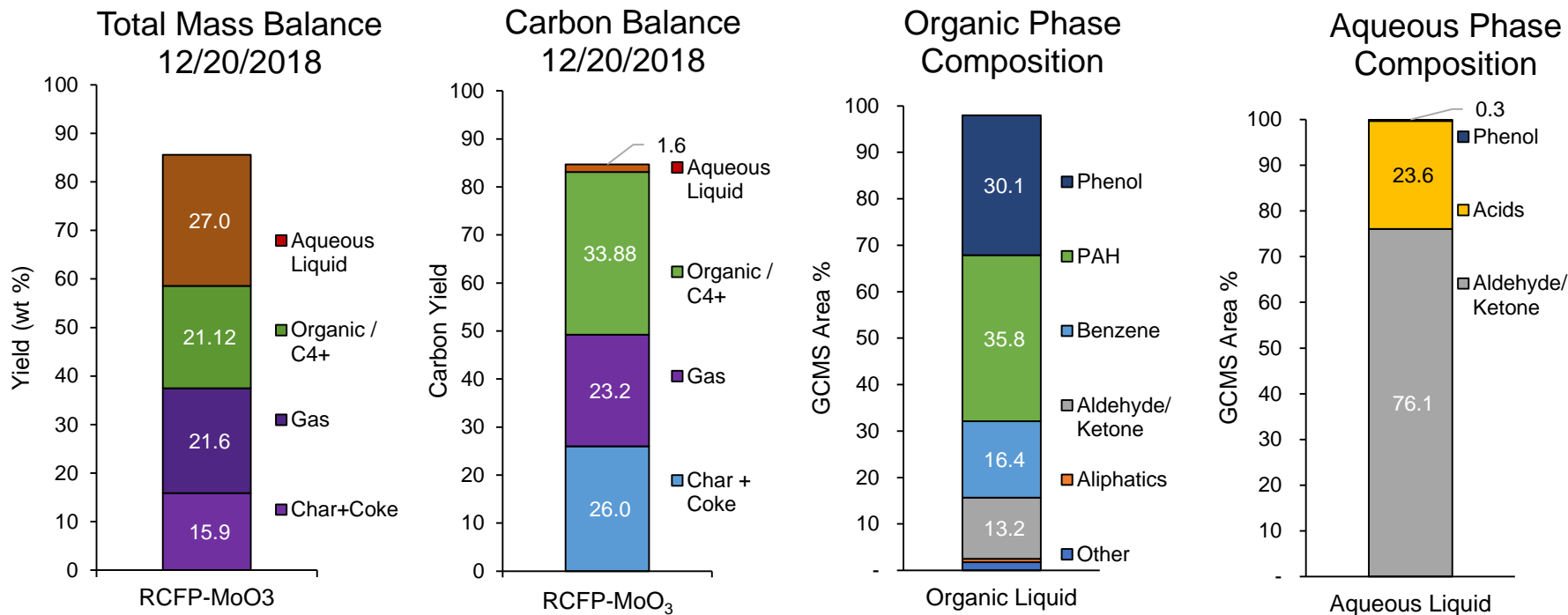

23.09 kg of biomass have been fed through the RCFP unit producing a total of 3.06kg (2.8L) of organic biocrude. Oxygen content is 12 Wt% db.

The semi-volatile compounds within the organic biocrude have been characterized by GCMS and are predominantly, PAH, phenol, and benzene compounds while the aqueous phase is mainly aldehydes/ketones.

- Phenols: Phenol, 2-methyl-phenol, 3-methyl-phenol
- PAH: Naphthalene, 2-methyl-naphthalene
- Aldehyde/Ketone: 2-cyclopentene-1-one, 2-methyl-2-cyclopentene-1-one, 5-methyl-2-Furancarboxaldehyde
- Benzene: p-xylene, Toluene
- Acids: Acetic acid

RCFP Biocrude Co-processing with Light GasOil

Analysis	Unit	LG	RCFP	10/90 RCFP/LG	15/85 RCFP/LG	20/80 RCFP/LG
SG at 60/60°F		0.8541	1.005	0.8667	0.8726	0.8782
O	wt %	-	9.65	-	-	2.17
S	wt %	1.30	0.001	1.14	1.04	1.01
N	wt ppm	148	425	165	180	201
H	wt %	13.09	8.28	12.59	12.43	12.18

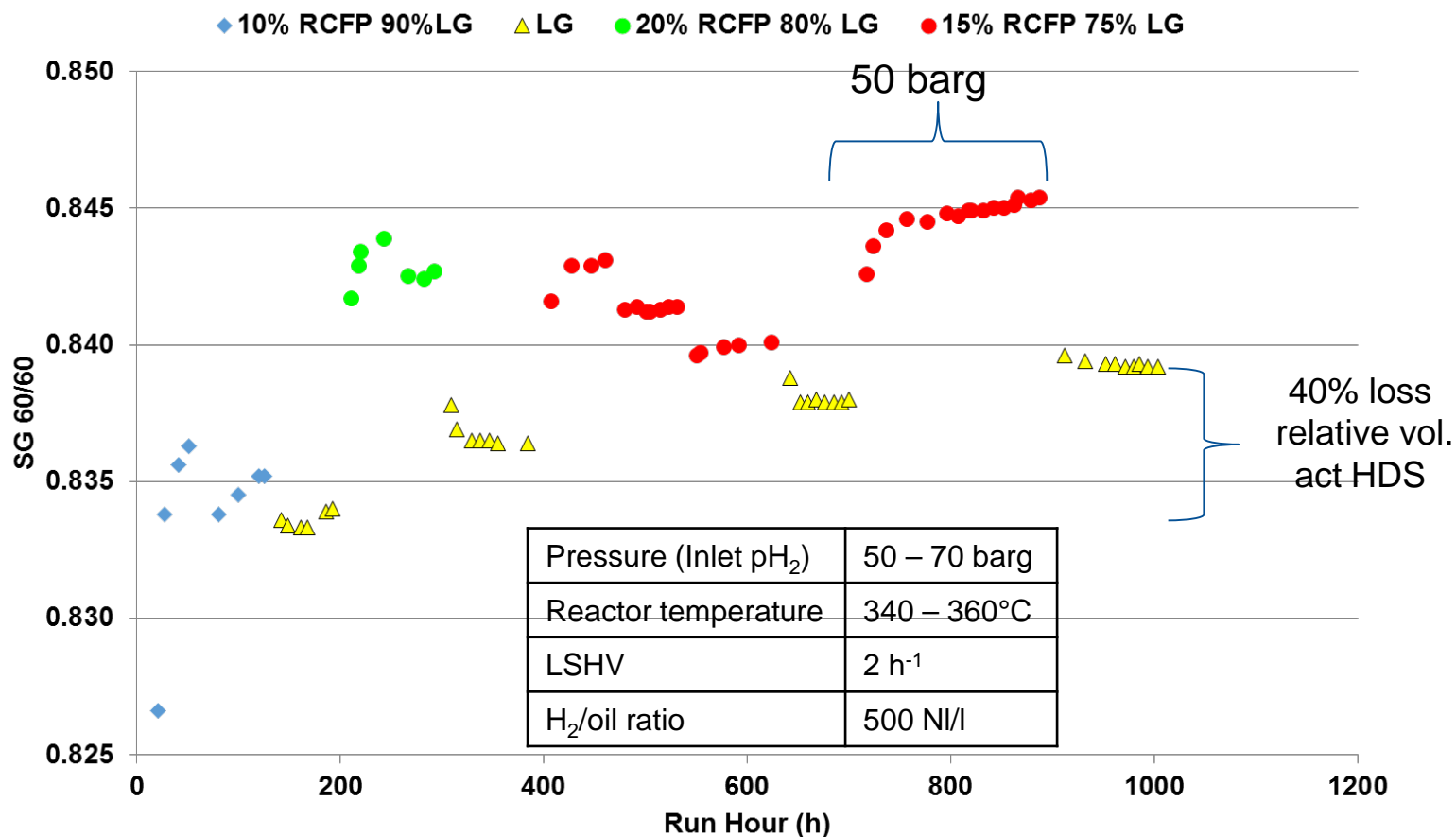

RCFP Biocrude Co-processing with Light GasOil

Yields, TLP properties and hydrogen consumption at similar HDS conversion

Feed	LG	RCFP/LG	RCFP/LG	RCFP/LG
	100	10/90	15/90	20/80
Temperature [°C]	340	340	360	350
Run hour [h]	192	51	624	292
SG, ASTM D4052	0.8340	0.8363	0.8401	0.8427
S, ASTM D7212/D5453 [wt ppm]	16	11	10	27
N, ASTM D4629 [wt ppm]	<1	<1	<1	<1
O, GC-AED [wt ppm]	-	<5	6	<5
H, ASTM D	13.79	13.70	13.53	13.41
CCI, ASTM D4737	58.8	56.0	54.1	51.9
H ₂ consumption [NI/I]	69	115	118	134
Yield C1 - C4 [%wt FF]	0.41	0.46	0.90	1.01
Yield C5+ [%wt FF]	98.9	98.4	97.6	97.1
Yield water [%wt FF]	-	1.06	1.59	2.11
Yield CO ₂ [%wt FF]	-	0.02	0.03	0.05
Yield CO [%wt FF]	-	0.02	0.03	0.02



- Test ran for > 1000 hours without shut-downs or severe deactivation
- Blended feed oxygen in the range 0.9 – 1.9 %wt
- Product oxygen ≤6 wt ppm
- Approximately 89 % of RCFP bio-crude converted to hydrocarbons on weight basis

Overview of AnMBR operation

- AnMBR system has been operated for 44 months.
- The system can convert 3% aqueous phase feed into methane.
- The percentage of wastewater in the feed has increased 150-fold over the duration of the project (0.02% → 3%).

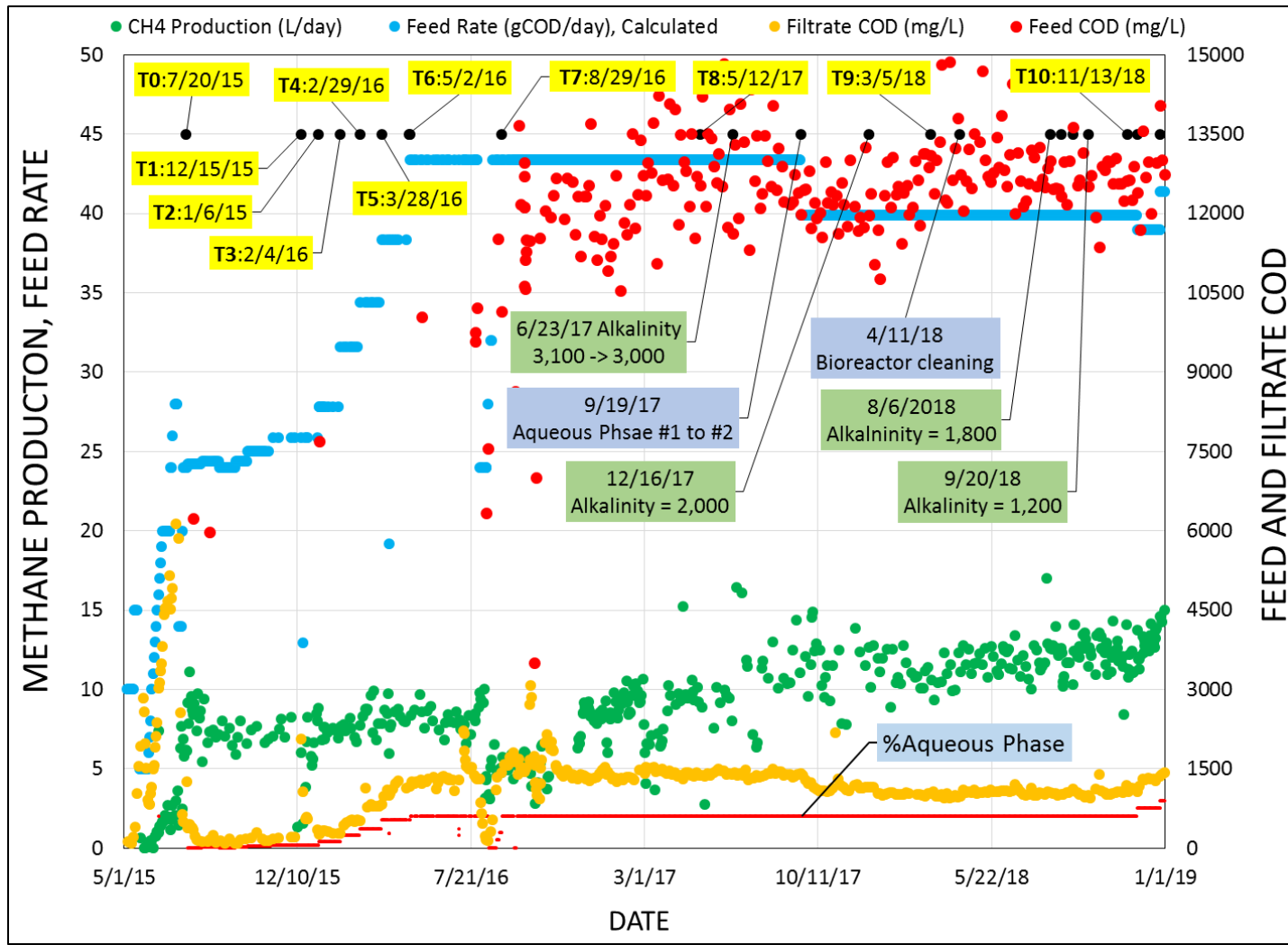

Biological carbon conversion performance

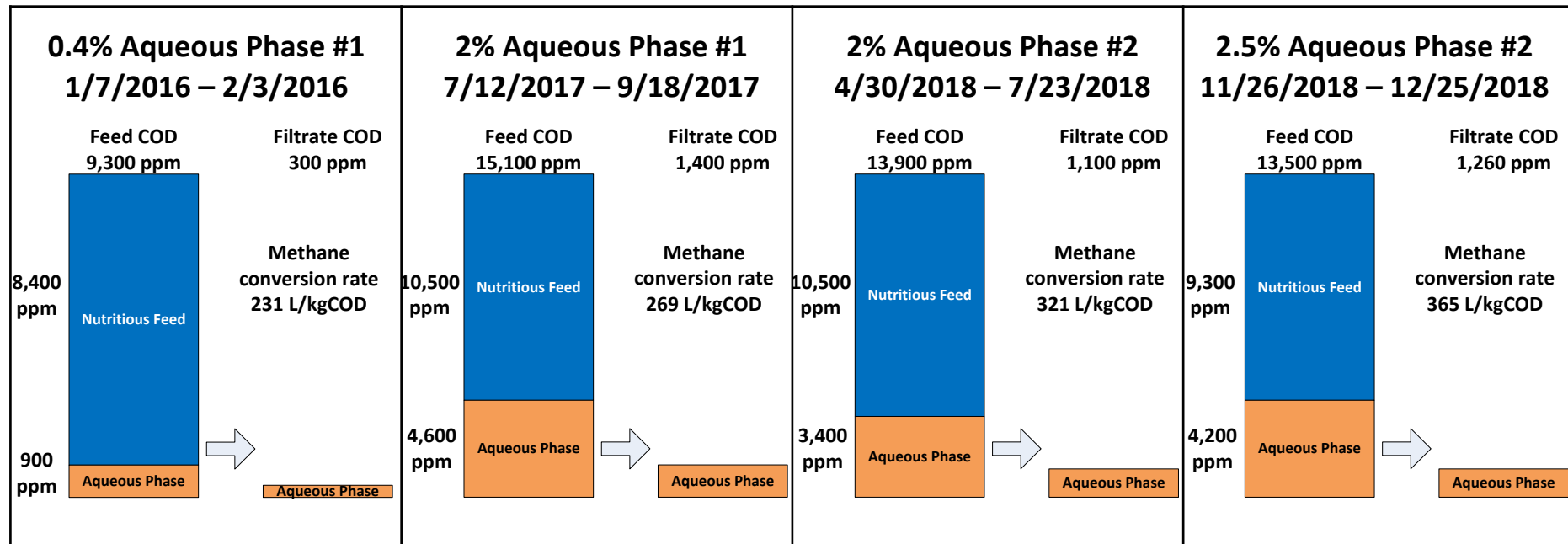

- The biological conversion efficiency improved as the microbial community acclimated with the aqueous phase carbon source.
- Assuming that the feed's nutrient components are 100% biodegraded, the conversion efficiency was improved from 67 to 70%.
- Average methane production - 12.3 L/day.
- Overall methane conversion efficiency - 0.25 kgCH₄/kgCOD
- 65% methane in biogas

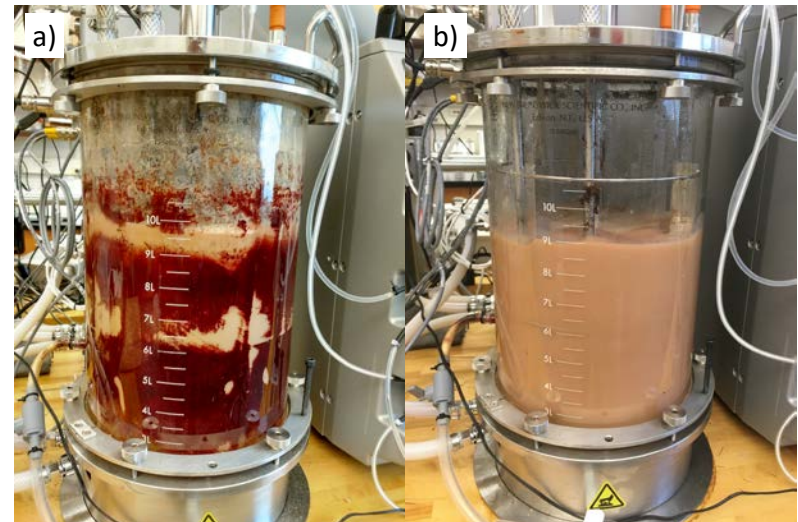

Anaerobic Digestion Microbial Community

The breakdown of organic matter and the generation of methane depend upon an interconnected network of microorganisms, both Bacteria and Archaea.

- Hydrolysis produces simple sugars, amino acids, and fatty acids (Bacteria)
- Fermentation or Acidogenesis produces volatile fatty acids (VFAs), carboxylic acids, alcohols, hydrogen, carbon dioxide, and ammonia (Bacteria)
- Acetogenesis produces acetate as well as CO_2 and H_2 (Bacteria)
- Methanogenesis, performed by highly specialized Archaea, converts the CO_2 , H_2 , and acetic acid into biogas, a mixture of about $2/3 \text{ CH}_4$ and $1/3 \text{ CO}_2$

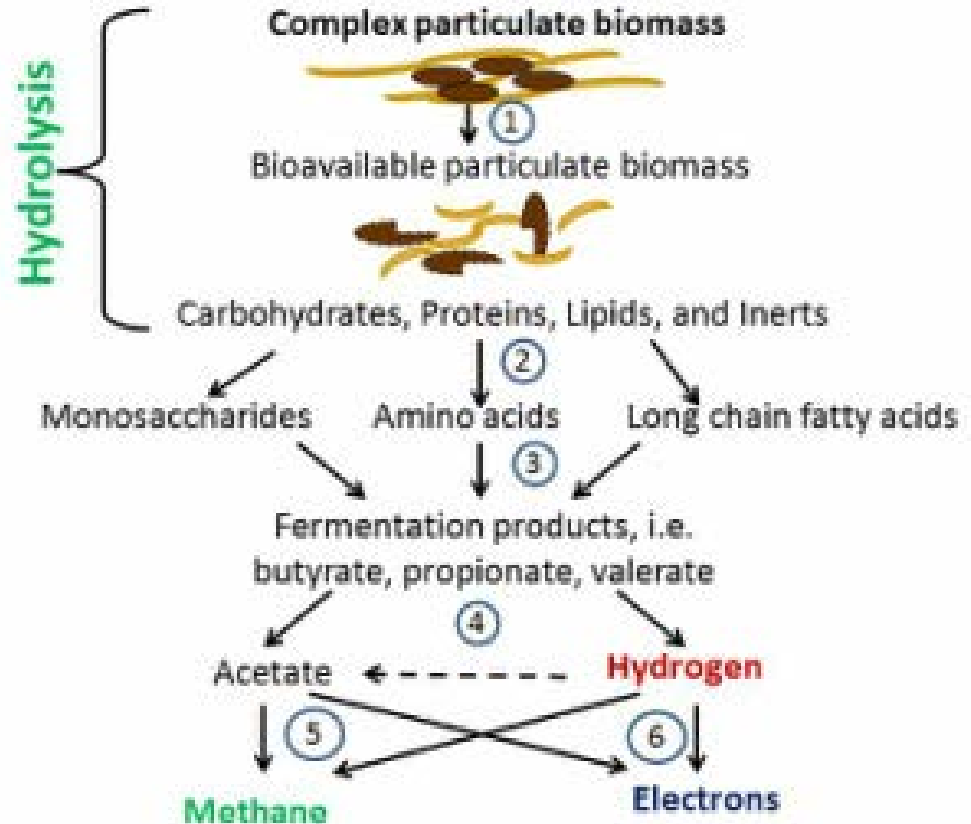

Microbial Community Adaption

- T0 (Before adding Aqueous phase): 5 dominant phyla evenly distributed: Spirochaetes, Firmicutes, Synergistetes, Bacteroidetes, and Euryarchaeota.
- T1 (5 months after adding Aqueous phase): Hydrocarbon degradation microorganisms Chloroflexi, Thermotogae, and WWE1 became dominant.
- T6 (Increased to 2% aqueous phase): Thermotogae and Bacteroidetes phyla accounted for more than 50% of the populations
- T9 (changing from sample #1 to sample #2): Microbial community unchanged

T0: 07-20-2015	T3: 01-16-2016	T6: 03-28-2016
T1: 12-07-2015	T4: 02-04-2016	T7: 05-02-2016
T2: 12-15-2015	T5: 02-29-2016	T8: 05-12-2017
	T9: 03-05-2018	

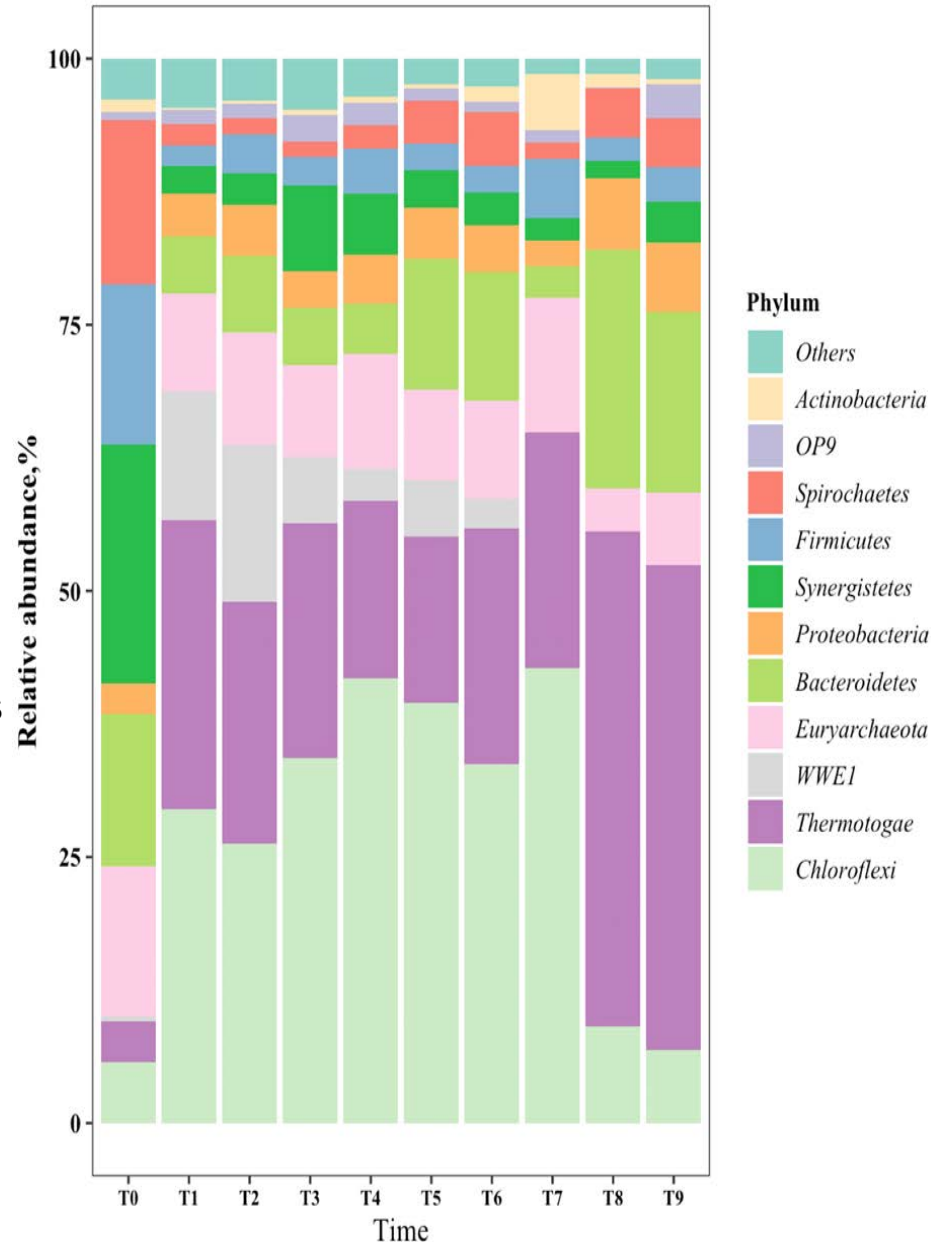

Techno-economic Analysis: 2000 DTPD

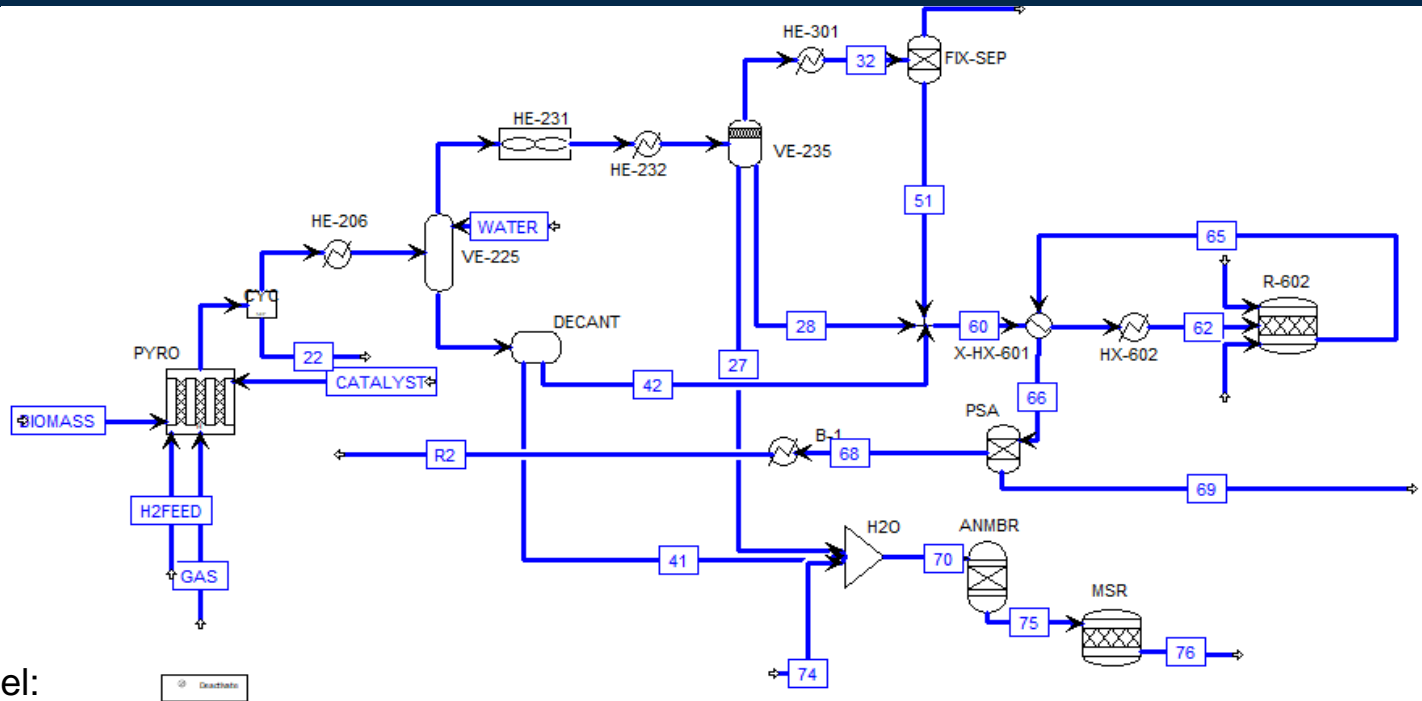

Updates to process model:

- Multi-train dryers and RCFP reactors to reflect equipment availability; vendor quotes; updated CAPEX is \$464MM
- Corrected element balances around RCFP reactor with improved bio-crude components and new pyrolysis simulation
- New simulation for hydrotreating based on bio-crude composition and matches experimental hydrogen demand
- Compare CFP and RCFP processes total production costs (\$/GGE) based on bio-crude yields and oxygen wt%.
- AnMBR provides 35-48% of the methane input to the steam methane reformer for hydrogen production (depending on carbon in wastewater)

	Hydrogen Consumption wt% (Conversion/HDT)	Bio-oil Organic/C ₄ + (wt%)	O (wt%)	Theoretical Gasoline Yield (wt%)	2,000 DTPD Gasoline Yield (US Gal/hr)	Total Production Costs, \$/GGE
RCFP	2.4 / 1.2	23.2%	9.8%	20.9%	5382	4.57
	3.1 / 0.7	23.6%	6.1%	22.2%	5702	4.31
CFP	0 / 2.0	20.0%	15.8%	16.8%	4327	5.68

4 - Relevance

- Hydrogen in the pyrolysis reactor improves bio-crude yield and quality while reducing char and coke formation
- Aqueous phase carbon recovery 1) maximizes the renewable carbon efficiency, 2) provides renewable methane for hydrogen production, and 3) improves recycled water quality so fresh water consumption is reduced.
- Low pressure process avoids potential operational issues feeding biomass across a pressure boundary
- Potential to reduce biofuels production cost with a novel, low-severity *in situ* CFP process to convert lignocellulosic biomass to hydrocarbon fuels.

- Fuel yields estimated from bio-crude yields measured in RTI reactor systems
- H₂ demand for RCFP and HYP measured
- H₂ demand for upgrading a function of bio-crude oxygen content
 - Measured for CFP and calculated for RCFP and HYP

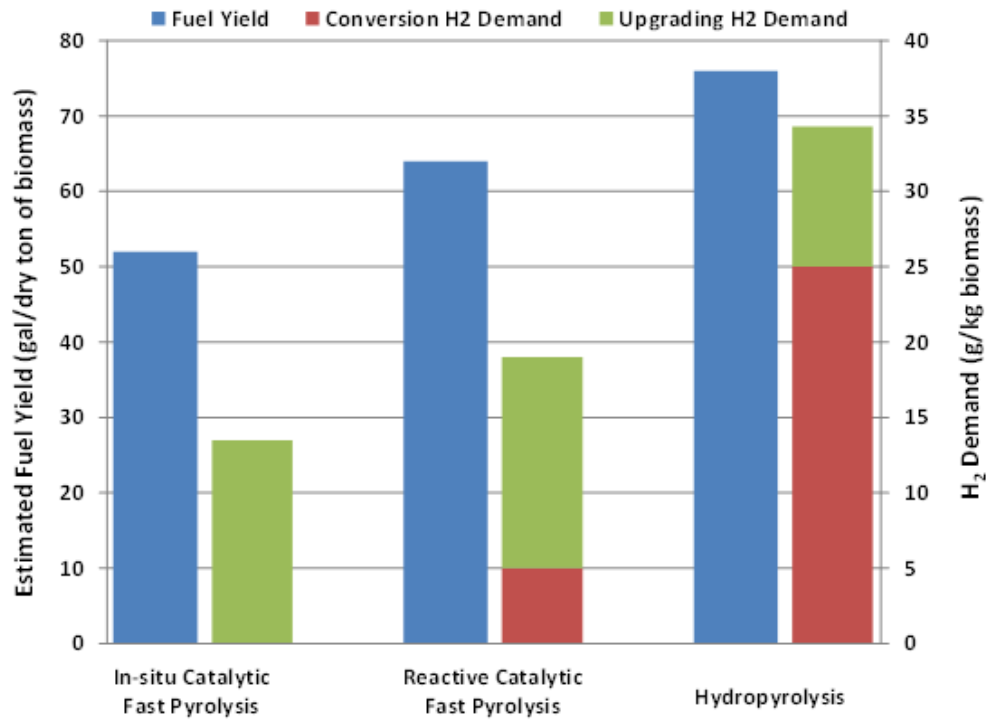

5 - Future Work

RCFP Bio-crude upgrading

- Validate RCFP bio-crude upgrading to gasoline- and diesel- range hydrocarbons
- Operate hydrotreating unit at RTI with RCFP bio-crude for up to 100 hours
- Determine hydrocarbon yields, hydrogen consumption and product split
- Compare hydrotreating study using RCFP bio-crude and CFP bio-crude

Aqueous Phase Carbon Recovery

- Assess methane conversion efficiency as aqueous phase portion in the AnMBR feed is increased to 5%.
- Continue to evaluate pretreatment processes such as ozone, UV, and H₂O₂
- Explore the feasibility of biohydrogen production in the AnMBR.

Techno-economic Analysis and Life-cycle Assessment

- *Update integrated process models with experimental data*
 - *bio-crude yields, hydrogen consumption, and bio-crude upgrading results*
 - *carbon recovery from the aqueous phases.*
- *CAPEX estimates for AnMBR for wastewater treatment*
- *DCFROR Analysis*

Summary

- Improve hydrogen utilization and carbon recovery in a direct biomass liquefaction technology where hydrogen is added to an atmospheric catalytic biomass pyrolysis process and aqueous phase carbon is converted to methane via anaerobic digestion.
- Catalyst development to identify catalysts that maximize biocrude yield and minimize biocrude oxygen content.
- Technical feasibility of biologically converting carbon in the aqueous phase to methane using anaerobic digestion has been demonstrated for 44 months.
- Experimental results inform TEA and LCA to determine technical and economic feasibility and environmental sustainability of the integrated process
- Final results will be used to evaluate TEA and LCA of novel, integrated advanced biofuels process

Acknowledgements



BETO Project Officer: Liz Moore

RTI Contributors

- David C. Dayton (PI)
- Phillip Cross
- Jonathan Peters
- Kelly Amato
- Joseph Weiner
- Ofei Mante
- Kaige Wang
- Gyu Dong Kim
- Elliott Reid

Haldor Topsoe

- Glen Hytoft
- Jostein Gabrielsen
- Sylvain Verdier

Veolia

- Herve Buisson

Additional Information – Publications and Patent

Publications

- Kristensen, M.; Hansen, A. B.; Mante, O. D.; Dayton, D. C.; Verdier, S.; Christensen, P.; Christensen, J. H., Complementary Analysis of the Water-Soluble and Water-Insoluble Fraction of Catalytic Fast Pyrolysis Biocrudes by Two-Dimensional Gas Chromatography. *Energy & Fuels* 2018, 32 (5), 5960-5968.
- K. Wang, D. Dayton, J.E. Peters, O. Mante, Reactive catalytic fast pyrolysis of biomass to produce high-quality bio-crude, *Green Chemistry*, 2017,19, 3243-3251
- Dayton, D.C., O.D. Mante, J.E. Peters, and K. Wang *Chapter 5 - Catalytic Biomass Pyrolysis with Reactive Gases in Fast Pyrolysis of Biomass*. 2017, Royal Society of Chemistry.
- Dayton, D. C.; Hlebak, J.; Carpenter, J. R.; Wang, K. G.; Mante, O. D.; Peters, J. E., Biomass Hydrolysis in a Fluidized Bed Reactor. *Energy & Fuels* 2016, 30 (6), 4879-4887
- Black, B. A.; Michener, W. E.; Ramirez, K. J.; Bidy, M. J.; Knott, B. C.; Jarvis, M. W.; Olstad, J.; Mante, O. D.; Dayton, D. C.; Beckham, G. T., Aqueous Stream Characterization from Biomass Fast Pyrolysis and Catalytic Fast Pyrolysis. *ACS Sustainable Chemistry & Engineering* 2016, 4 (12), 6815-6827
- Peters, J. E.; Carpenter, J. R.; Dayton, D. C., Anisole and Guaiacol Hydrodeoxygenation Reaction Pathways over Selected Catalysts. *Energy & Fuels* 2015, 29 (2), 909-916

Patent

- U.S. Patent US2016/0222298A1 for hydrogen addition during catalytic biomass pyrolysis entitled "Reactive Catalytic Fast Pyrolysis Process and System" published August 4, 2016.

Additional Information - Presentations

Presentations

- D.C. Dayton, “Challenges and Opportunities for Advanced Biofuels and Bioproducts” 2018 Symposium on Thermal and Chemical Sciences for Biofuels and Biobased Products (TCS2018), Auburn University, October 8-10, 2018.
- G.-Kim, Y.-Choi, K.-Wang, Q.-He, Z.-Hendren, E.M.-Reid, O.-Mante, D.-Dayton, H.-Buisson, G.-Rosenberger. “Biological Carbon Recovery From the Advanced Biofuel Process Wastewater Using Anaerobic MBR” in Session 500 “Resource Recovery at Industrial Wastewater Treatment Plants” at the 91st Annual Water Environment Federation Technical Exhibition & Conference in New Orleans, LA Sept 29 – Oct 3, 2018.
- K. Wang, D. Dayton, O. Mante, J. Peters. Reactive Catalytic Fast Pyrolysis of Biomass to Produce Hydrocarbon-rich Bio-crude, TCS2016, Chapel Hill, NC. Nov.2016.
- K. Wang, D. Dayton, O. Mante, J. Peters. Reactive Catalytic Fast Pyrolysis of Biomass to Produce High-quality Bio-crude, TCBIomass 2015, Chicago, IL. Nov.2015.
- M. Von Holle, “Small Scale Catalyst Testing with Biomass for Advanced Biofuels Technology Development.” Poster Presentation, TCBIomass 2013 September 3-6, 2013 Chicago, IL.
- J. Carpenter, “Low Oxygen-Content Bio-Crude via Single Step Hydrolysis.” Poster Presentation, TCBIomass 2013 September 3-6, 2013 Chicago, IL.
- J. Hlebak, “Experimental Capabilities at RTI International to Support R&D for Direct Biomass Liquefaction Pathways.” Poster Presentation, TCBIomass 2013 September 3-6, 2013 Chicago, IL.
- J. Peters, “Deoxygenation Chemistry of Bio-oil Model Compounds with Selected Catalysts.” Poster Presentation, TCBIomass 2013 September 3-6, 2013 Chicago, IL.

Previous Review Comments

2017 PROJECT PEER REVIEW

IMPROVED HYDROGEN UTILIZATION AND CARBON RECOVERY FOR HIGHER-EFFICIENCY THERMOCHEMICAL BIO-OIL PATHWAYS

(WBS#: 2.5.4.405)

Project Description

This project focuses on the potential for improved hydrogen utilization and carbon recovery in a novel, direct biomass liquefaction process. The primary objective is to use hydrogen during in-situ catalytic biomass pyrolysis to maximize the biomass carbon and energy recovery in a low-oxygen-content, thermally stable biocrude intermediate that can be efficiently upgraded into a finished biofuel. The secondary objective is to improve the carbon efficiency of the integrated process by converting the carbon in the aqueous stream to methane for hydrogen production. New and novel catalysts are being developed to improve hydrodeoxygenation during cata-

Recipient:	Research Triangle Institute
Principal Investigator:	Dave Dayton
Project Dates:	8/1/2014–12/31/2017
Project Category:	Ongoing
Project Type:	FY 2013–CHASE: DE-FD4-0000812
Total DOE Funding:	\$3,140,528
DOE Funding FY 2015:	\$0
DOE Funding FY 2016:	\$0
DOE Funding FY 2017:	\$800,000

lytic biomass pyrolysis to reduce biocrude oxygen content, reduce char formation, and subsequently improve hydrogen utilization during biocrude upgrading. We are evaluating anaerobic digestion for aqueous-phase carbon conversion to methane that can be reformed for hydrogen production.

Overall Impressions

- This is a well-managed and well-run project providing details and clear goals and accomplishments. The team is to be commended. I see no issues or



PHOTO COURTESY OF RESEARCH TRIANGLE INSTITUTE

concerns other than catalyst lifetime, which will be worked on in phase 2.

- This is a very interesting project; however, it is basically integrated hydro-pyrolysis plus hydroconversion technology (IH2) "light." It confirms the benefit of using a hydrogen transfer catalyst and added hydrogen on retention of carbon during pyrolysis. However, IH2 has already demonstrated this fact. The unique feature in this approach is lower-pressure operation. The anaerobic digester work shows the potential of this technique to produce hydrogen for the process. However, there are still concerns about the toxicity of the feed. The long time scale needed to condition the microbes will be a significant operational constraint.
- This is a good project for a highly integrated technology, which results in a more efficient process scheme. Techno-economic analysis will confirm if the integrated process is competitive (high capital cost?).

- Overall, this is a solid project that contributes to a growing portfolio of fast pyrolysis reactors capable of running under H₂ atmosphere. That said, at commercial scales, even if the hydrogen comes from light gases produced *in situ*, natural gas steam-methane reforming will be more economic and financeable. Furthermore, it is widely known that high H₂ partial pressures reduce coking and increase liquid yields. So, it is not clear how this project has advanced the state of the art in that regard. An expanded look at carbon efficiency versus realistic product value needs to take place, starting with a close look at "where" carbon efficiency should take place (based on what has been learned in the last 10 years of pyrolysis research). If the objective is to convert the pyrolysis liquid into a fuel blendstock outside of a refinery, the most economical way to do this is the removal of oxygen, not through hydrogenation, but through staged pyrolysis since the light pyro-gases often contain the most O₂. If the objective is to make value-added chemicals (such as fuel/oil additives) from biomass, then keeping the oxygen and leveraging the reactivity of biomass chemistry to make valuable non-hydrocarbon chemicals makes the most sense. Trying to solve these challenges through brute force H₂ hydrogenation and utilization of catalysts in harsh conditions is unlikely to be constructive in the long term.
- This is an ambitious project, but I'm skeptical that the overall, integrated process for catalytic pyrolysis in the presence of hydrogen will result in improved operability compared with "conventional" catalytic fast pyrolysis.

PI Response to Reviewer Comments

- There is no doubt that hydro-pyrolysis is an effective process for producing a low-oxygen content biocrude with improved yields and reduced char formation compared to catalytic fast pyrolysis; however, we feel that one of the more significant chal-

Weighted Project Score: 7.5

Weighting: For ongoing projects, there is equal weighting across all four evaluation criteria: Approach, Relevance, Accomplishments and Progress, and Future Work.

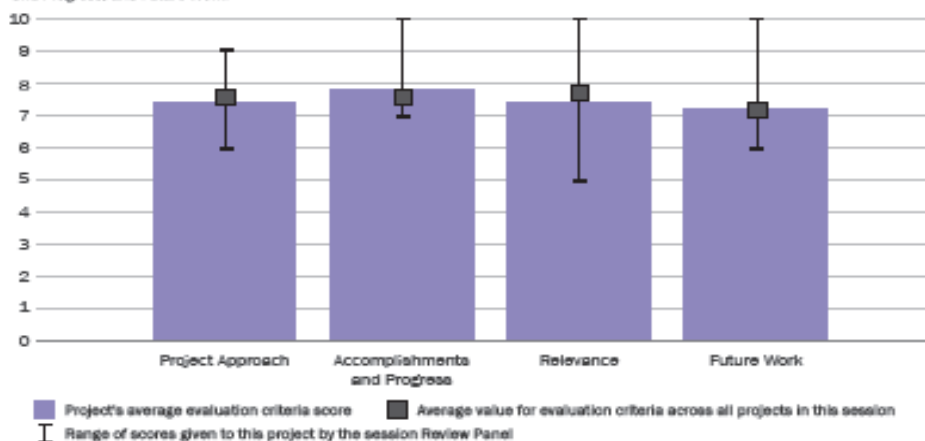

Previous Reviewers' Comments – Project Approach

Hydrogen consumption was significant and still generated a pyrolysis liquid with too much O₂ to be appealing to a petrochem refinery. Focus on H₂ hydrogenation has reached an inflection point. Crude oil is produced as a 3-phase flow (oil/gas/water) that is unstable and when cool, does not flow. This mixture is separated as best as possible and then transported under warm conditions to a refinery where considerable amounts of hydrogen are used to convert it into functional petrochem products. It is no longer compelling for us to address pyrolysis liquid instability by reacting the entire mixture with hydrogen. This is extremely expensive and does not take into consideration the unique chemical differences between crude oil (or oils in general) and pyrolysis liquids (which are not oils). An expanded look at carbon efficiency vs realistic product value needs to take place. If the objective is to convert the pyrolysis liquid into a fuel blendstock outside of a refinery, the most economical way to do this is the removal of oxygen, not through hydrogenation, but through staged pyrolysis since the light pyro-gasses often contain the most O₂. Low price of natural gas and major increases to gas supply from fracking have all but eliminated the value of generating light HC gasses from pyrolysis liquids.

Response: Biomass is hydrogen deficient with H/C_{eff} ratios typically below 0.5, compared to 1~2 for petroleum-derived feedstocks. Thus, hydrogen is needed in any direct biomass liquefaction process for production of drop-in transportation fuels. Reactive catalytic fast pyrolysis (RCFP) being developed in this project aims to improve hydrogen utilization during biomass conversion and increase the H/C_{eff} ratios in the resulting bio-crude. Under optimized reaction conditions, the RCFP bio-crude contains as low as ~6wt% oxygen, compared to 20wt% -30wt% for conventional CFP process. Moreover, the H/C_{eff} of the RCFP bio-crude increases up to to 1.07 compared to 0.4 to 0.8 for conventional CFP bio-crude. Because of the improved quality of the resulting bio-crude, the RCFP process is expected to be more readily integrated with downstream hydroprocessing to produce drop-in blendstocks or finished biofuels for transportation. In cooperation with our partners at Haldor Topsoe, Hydroprocessing of the RCFP bio-crude will be investigated in the Phase 2 of this project.

-
1. Overall project focuses on two technologies that are not directly related although both could ultimately be deployed in a bio-refinery concept. It is not clear why these technologies were included in the same project as opposed to funded separately.
 2. Project plan with milestones tied to tasks is reasonably detailed. A clear summary of project technical achievements against milestones would have been appreciated.

Response: The overall goal of this project is to evaluate the potential for improved hydrogen utilization and carbon recovery in a direct biomass liquefaction process. One aspect of the concept is to use hydrogen during in-situ catalytic pyrolysis to improve yield and quality of the bio-crude intermediate and minimize the char/coke formation. Aqueous phase is an inevitable waste stream from any advanced biofuel processes. Carbon efficiency of the integrated process is improved by recovering aqueous phase carbon to produce methane, which is used as a source of hydrogen for RCFP. Interestingly enough, the better the RCFP process works in removing oxygen from the bio-crude, the less water-soluble organic hydrocarbons there are and the lower the carbon content of the aqueous fraction. Carbon and energy recovery from the aqueous phase has potential to lower the hydrogen demand and overall greenhouse gas emission for the integrated process.

Previous Reviewers' Comments – Accomplishments and Progress

- 1) Impressive results from program meeting all goals set for phase 1.
- 2) Impressive use and efficiency of biomass and consolidation of the water waste for upgrading and energy.

Integrated lab-scale reactor is impressive and data quality is high. Low pressure operation is notable. Integration of system with an AD and work to slowly evolve AD microbial community to metabolize aqueous components is compelling.

-
1. Incorporation of catalyst with hydrogenation function in CFP to improve deoxygenation and reduce coke formation is an attractive idea. However, from a process standpoint catalyst regeneration is likely to be challenging. It is unlikely that carbon burn, the regeneration process typical for FCC/CFP operation, would maintain catalyst integrity for many cycles. (And moving between oxygen and hydrogen rich reactors is tricky from a safety standpoint.) The only viable regen would be a mild hydrogen stripping of carbonaceous deposits.
 2. Author's comment (slide 8) that consistent results between Pyrolyzer-GC and fluidized unit are obtained are impressive. It would have been worthwhile seeing the tie-line between the two sets of data.
 3. Anaerobic digestion of carbon containing waste water is well known. Is the incorporation of a membrane a technical innovation?
 4. However the demonstration of letting the organism acclimate to bio-oil components was interesting.
 5. The alternate proposed idea of recovering carbon from the aqueous phase in a form suitable for return to the hydrotreater seems more novel but no results were shown.

Response: Catalyst regeneration during RCFP is one of the technical challenges for scaling up the process to the 1TPD pilot plant scale. Hydrogen stripping may only remove the “soft” coke, while the “hard” coke remains. Thus oxidation of the coked catalysts to burn off the carbonaceous materials will be required ultimately. We will perform additional laboratory experiments to evaluate the efficacy of other regeneration options and develop a strategy for catalyst regeneration in the pilot plant tests.

Anaerobic digestion (AD) has been done commercially for decades in the food processing, agricultural, and wastewater treatment industries with well-defined inputs. The application of AD to a biomass pyrolysis aqueous stream is unique to this project. The use of a membrane keeps the digester biomass in the reactor but the innovation is the adaption of the microbial population in the sludge for converting carbon in the aqueous phase containing various organics, many of which can be toxic to anaerobic microorganisms. One goal of the project is to improve the conversion efficiency of anaerobic digestion using proper pretreatments and process optimization. We found initially that biofuel wastewater was very toxic to the anaerobic digestion, even at 0.02% addition, by BMP tests. We have since started very slow on acclimation and we have improved the performance significantly and went from zero removal to more than 70% removal and conversion to CH₄. We are now working on the pretreatment of the biofuel so that the toxicity is reduced and bioavailability is improved.

Previous Reviewers' Comments – Relevance

The project address carbon efficiency and hydrogen uses are two of the key barrier facing catalytic fast pyrolysis. It moves closer to the goal of avoiding the need provide external hydrogen to the upgrading process.

The approach adds complexity and capital costs to the catalytic pyrolysis process.

Response: Waste water treatment process is required for any commercial-scale biorefinery processes. Instead of adding complexity and capital costs, the integrated process proposed in this project try to fully integrate pyrolysis process and waste water treatment process to improve energy and carbon efficiency and reduce overall cost. The integrated process is more realistic and potentially economical-feasible compared to other stand-alone catalytic pyrolysis process

It is widely known that high H₂ partial pressures reduce coking and increase liquid yields. It is not clear how this project has advanced the state of the art in that regard. Relevance cannot be driven by \$3/GGE and the ability to produce hydrocarbons through hydrogenation. In all likelihood, \$3/GGE is too high because it is based on models and not an existing, commercialized (and economic) biomass to hydrocarbon facility.

Response: For direct biomass liquefaction processes, only hydrolysis has shown that high pressure hydrogen can reduce coke and improve bio-crude yields. Several groups including RTI have demonstrated the technical feasibility of HYP process. However, there is scant literature detailing the benefits of utilizing hydrogen at low pressure. The basic concept of this project to develop an atmospheric pressure process with similar technical performance to HYP as an alternative that avoids the technical challenges associated with feeding biomass at high pressure.

Previous Reviewers' Comments – Overall Impression

This is a very interesting project however it is basically IH2 "light". It confirms the benefit of using a hydrogen transfer catalyst and added hydrogen on retention of carbon during pyrolysis. However, IH2 has already demonstrated this fact. The unique feature in this approach is lower pressure operation. The anaerobic digester work shows the potential of this technique to produce hydrogen for the process. However, there is still concerns about the toxicity of the feed. The long time scale needed to condition the microbes will be a significant operational constraint.

Overall, a solid project that contributes to a growing portfolio of fast pyrolysis reactors capable of running under H2 atmosphere. That said, at commercial scales, even if source of hydrogen comes from light gasses produced in-situ, natural gas SMR will be more economic and financeable. Furthermore, it is widely known that high H2 partial pressures reduce coking and increase liquid yields. So, it is not clear how this project has advanced the state of the art in that regard. An expanded look at carbon efficiency vs realistic product value needs to take place, starting with a close look at "where" carbon efficiency should take place (based on what has been learned in the last 10 years of pyrolysis research). If the objective is to convert the pyrolysis liquid into a fuel blendstock outside of a refinery, the most economical way to do this is the removal of oxygen, not through hydrogenation, but through staged pyrolysis since the light pyro-gasses often contain the most O2. If the objective is to make value added chemicals (such as fuel/oil additives) from biomass, then keeping the oxygen and leveraging the reactivity of biomass chemistry to make valuable non-HC chemicals makes the most sense. Trying to solve these challenges through brute force H2 hydrogenation and utilization of catalysts in harsh conditions is unlikely to be constructive in the long term.

Response: There is no doubt that hydrolysis is an effective process for producing a low oxygen content bio-crude with improved yields and reduced char formation compared to catalytic fast pyrolysis; however, we feel that one of the more significant challenges for scaling up this technology will be feeding biomass into a pressurized reactor. That said, we are anxiously following the scale-up activities for the IH2 technology.

We have taken the approach to address this technical challenge by developing an atmospheric pressure process that utilizes hydrogen in a catalytic biomass pyrolysis process – RCFP – yet yields the same bio-crude yields and quality as the high-pressure process. There is scant literature detailing the benefits of utilizing hydrogen in biomass pyrolysis at low pressure outside of small microreactor systems and model compound studies. This project aims to fill that technical gap and provide information for hydrodeoxygenation of biomass pyrolysis vapors at the large laboratory and pilot scales.

The RCFP process is also integrated with an anaerobic digestion process to investigate the potential of recovering carbon from the aqueous phase and converting it into renewable methane. Anaerobic digestion (AD) has been done commercially for decades but the application of AD to a biomass pyrolysis aqueous stream is unique to this project. In fact, with methane from the AD, no additional fossil hydrogen is required in the process ensuring that it meets the 50% greenhouse gas emissions reduction required for advanced biofuels. This opens the possibility of finding alternative uses for the pyrolysis gases.

Initially, the biofuel wastewater was very toxic to the microbes, even at 0.02% addition, by BMP tests. We have since started very slow on acclimation and we have improved the performance significantly and went from zero removal to more than 70% removal and conversion to CH4. The innovation is the adaption of the microbial population in the sludge for converting carbon in the aqueous phase containing various organics, many of which can be toxic to anaerobic microorganisms. Future work in the project is focused on improving the carbon conversion in AD using proper pretreatments and process optimization.

Catalyst regeneration during RCFP and safe addition of hydrogen to the 1TPD pilot plant remain technical challenges for scaling up the process. We will perform additional laboratory experiments to evaluate the efficacy of other regeneration options and develop a strategy for catalyst regeneration in the pilot plant tests. Efforts are also underway at RTI to produce large quantities of fluidizable and attrition resistant catalysts.