

Passive Envelope Advancement

Integrated Design, Construction, and Industrialized Buildings

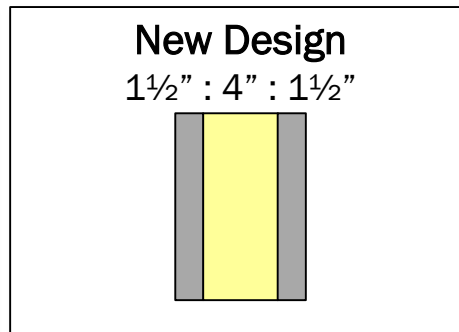
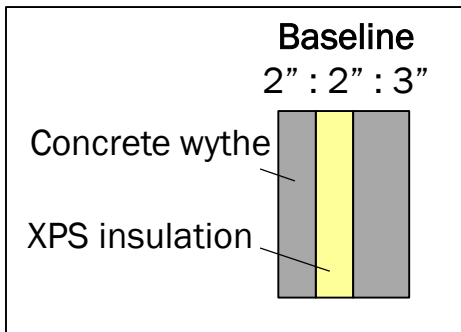

Next Generation of Precast Insulated Concrete Walls

- 50% lighter
- 50% higher thermal performance
- Cost neutral design

Assessment of Techniques to Retrofit Commercial Building Envelopes

Before Retrofit



Rendering of
Retrofitted Building



Oak Ridge National Laboratory
Diana Hun, Subprogram Manager for Building Envelopes
hunde@ornl.gov

Project Summary

Timeline:

Start date: 4/1/16

Planned end date: 3/30/21

Key Milestones:

1. Stripping lifting insert achieved 10K lb. capacity
2. Concrete mix ≥ 600 psi flexural strength at 12 hours

Budget:

Total Project \$ to Date:

- DOE: \$1.08M
- Cost Share: \$1.73M

Total Project \$:

- DOE: \$2.68M
- Cost Share: \$4.63M

Key Partners:



THE COMPOSITES INSTITUTE

THE UNIVERSITY of TENNESSEE **UT**



CHINA STATE CONSTRUCTION ENGINEERING CORPORATION

Project Outcomes:

- Next-gen precast insulated walls for new commercial buildings
- Evaluation of commercial envelope retrofits
- New air sealing technologies

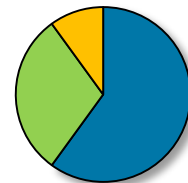

Year 1
4/16 - 3/17

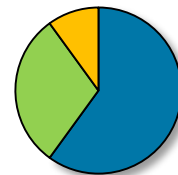

Year 2
4/17 - 3/18

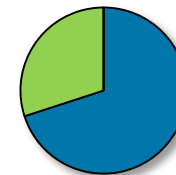

Year 3
4/18 - 3/19

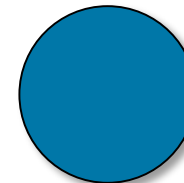

Year 4
4/19 - 3/20

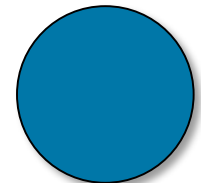

Year 5
4/20 - 3/21

Team

Next Gen of Precast Insulated Concrete Walls

Guidance on Industry Needs



R&D



Adopter

PCI's 2016 Organizational Members

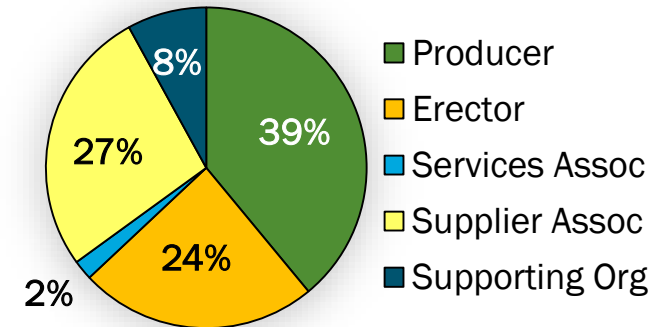

- 375 organizational members
- 2500 individual members

Envelope Retrofits and Air Sealing Technologies

Building Owners

- Dundee Theater
- City of Madison
- Others



Building Envelope and Blower Door Consultants



R&D



Payback period
Lessons learned

US

Shenzhen Building



New Air Sealing Technology



R&D



Payback period
Lessons learned

China

Challenge

New commercial buildings

Quality control is difficult to enforce in onsite construction, which can compromise the energy efficiency and durability of the building envelope. Prefabrication supplies better quality control and building envelopes with fewer defects. Precast concrete stands out because of its high durability.

Onsite Construction



Prefabrication



ASHRAE Standard 90-75 
Energy Conservation in New Building Design

First US energy standard published in 1975

Existing commercial buildings

~50% of buildings lack or have minimal insulation and lack an air barrier system because they were built before energy codes. Retrofit data are needed to show building owners the energy savings potential from building envelope renovations.

Air sealing technologies

Air sealing technologies are highly dependent on workmanship. To meet airtightness requirements, general contractors need robust air barrier technologies that are easy-to-install.

Tape



Spray-applied flashing



Approach: Precast Walls

Goal: Advance technologies for precast concrete, which is the most successful prefabrication system for commercial buildings.

1. Cost neutral design

2. Reduce weight by $\geq 50\%$

- 1½"-thick concrete wythes
- Lower concrete density: 100 pcf
- New concrete mix: 600 psi flexural strength at 12 hours
- Non-corroding accessories made of composites: lifting inserts, panel-to-building connectors

2. Double thermal performance

- More insulation w/o increase in panel thickness
- Non-corroding accessories with low thermal conductivity
- Airtight panel joints

3. Shorter production time

- Faster manufacture of complex molds
- New concrete mix to double plants' capacity

4. Improve air/water tightness of panels joints

- New primer-less self-healing sealant

Baseline

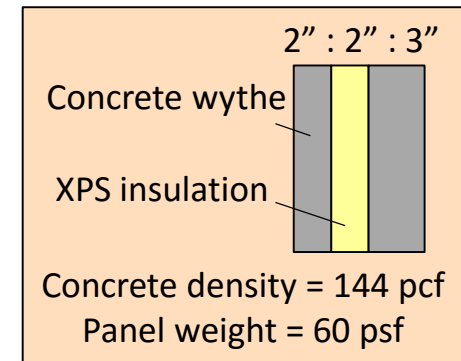

New design

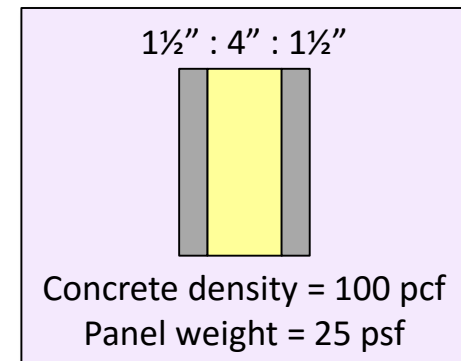

Impact: Precast Walls

- **BTO 2030 goal: reduce energy use per ft² by 30% relative to 2010**
 - Defects in building envelopes are harder to prevent in onsite construction
- **Contributions from precast advancements to BTO's goals**
 - Higher thermal performance
 - Double the amount of insulation w/o increasing the wall thickness
 - Improved air and water tightness
 - Few locations for leakage w/up to 60 ft long panels
 - New primer-less, self-healing sealant
 - Reduced thermal bridging
 - Continuous exterior insulation
 - Replacing steel parts with fiber reinforced polymer accessories
- **Validation of expected benefits**
 - Use of developed technologies in pilot building

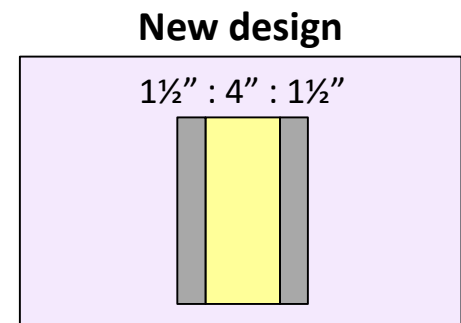
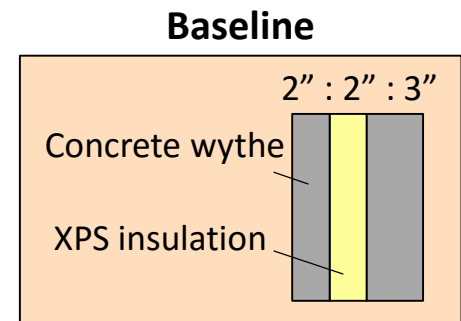

Progress: Precast Walls

- After ~22 months of R&D
- Successful large-scale trial of 1 ½”-thick wythes
 - ~105 pcf
 - ~600 psi flexural strength at 12 hours
 - ~\$300/yd³
- Non-corroding inserts meet target loads
 - Erection lifting insert \cong 13,000 lbs.
 - Stripping lifting insert \cong 10,000 lbs.
- Shorter production time: 3D printed molds
 - Ongoing validation through Domino Sugar building
 - Disseminating lessons learned to PCI members
- Primer-less self-healing sealant
 - Prototype recovers elastic properties in 2 hours

Invention Disclosures



High-performance concrete mix for 1.5”-thick wythes



Non-corroding erection lifting inserts



Non-corroding stripping lifting inserts

Domino Sugar Building - NYC



First building in the world with a façade made with 3D printed molds



Rendering

Stakeholder Engagement: Precast Walls

- **PCI Advisory Board**
 - Guides project based on industry needs
 - ~Bi-monthly progress updates
- **Knowledge dissemination**
 - 15+ precasters visited ORNL and Gate Precast
 - 2018 PCI Convention, which is the largest gathering of precasters in the US
 - 2018 American Concrete Institute Strategic Development Council

PCI members at ORNL learning about manufacturing of 3D printed molds.



PCI members at Gate Precast learning about casting concrete with 3D printed molds.



PCI members at Gate Precast learning about the quality of the concrete parts that are casted with 3D printed molds.



Remaining Project Work: Precast Walls

- **Optimize designs**
 - Concrete mix for 1½”-thick wythes
 - Erection and stripping lifting inserts and bolted tieback connections
 - File patent applications
- **Start or continue designs**
 - High early strength concrete mix to use casting beds twice per day
 - Bolted tieback connection
 - Primer-less, self-healing sealant
- **3D printed molds**
 - Finish manufacturing molds for Domino project
 - Start installation of precast parts in building
 - ~2020 building completion
- **CSCEC (China partner)**
 - Determine IP exchange process

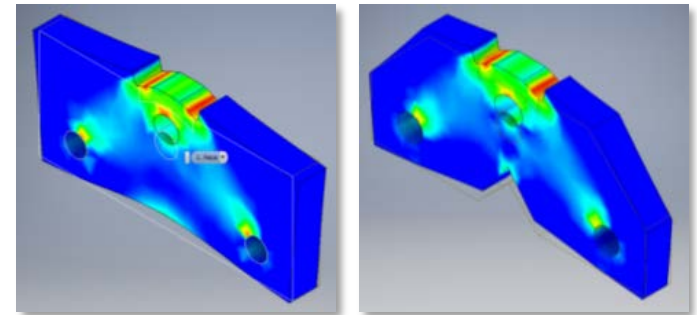

Example of design optimization of erection lifting inserts using finite element analyses.

Approach: Envelope Retrofits

Goal: Gather data from commercial building envelope retrofits to estimate energy savings and payback time.

1. Identify case studies

- a. Reduce air leakage
- b. Decrease heat transfer thru conduction
- c. Owner willing to allow blower door test

2. Collect data before and after retrofit

- a. Envelope assembly
- b. Air leakage rates

3. Estimate energy savings through simulations

4. Estimate return on investment

5. Disseminate knowledge



Impact: Envelope Retrofits

- **BTO 2030 goal: reduce energy use per ft² by 30% relative to 2010**
 - ~75% of existing building stock will still be in service in 2050
 - ORNL's Lab Corps study
 - Minimal data available on commercial building envelope retrofits
 - Energy service companies (ESCOs) place envelope retrofits at the bottom of their list
- **Contributions from envelope retrofits to BTO's goals**
 - Real data from commercial buildings
 - Improved in airtightness
 - Reduced heat transfer
 - Energy savings and payback time estimates
- **Validation of expected benefits**
 - Air leakage measurements before and after retrofit

Progress: Envelope Retrofits

- After ~22 months of R&D
- Completed retrofit
 - 1969 office in Wilkesboro, NC
 - 8,000 ft² floor area
 - Before and after retrofit
 - Air leakage from 2.8 to 0.37 cfm/ft² at 75 Pa
 - No insulation on walls to R5
 - Benefits
 - ~40% decrease in electricity use
 - ~90% decrease in natural gas use
 - ~\$2,400 annual savings
- Three ongoing retrofits
 - Dundee theater, Omaha, NE
 - Madison municipal building, Madison, WI
 - Office in Dallas, NC

Office Building in Wilkesboro, NC



Infrared Images of Leaks Before Retrofit

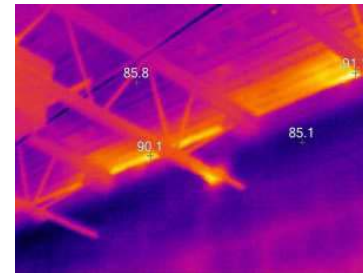

Wall-to-roof interface

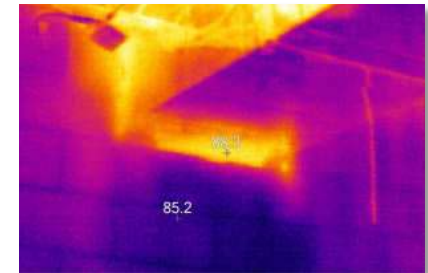

Perimeter of duct penetration

After Retrofit Simulation Results

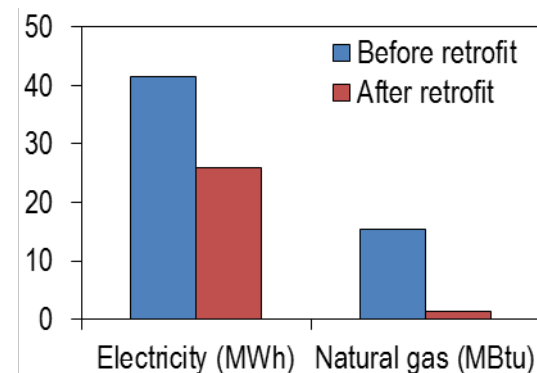

Stakeholder Engagement: Envelope Retrofits

- **Retrofit team**

- Owner's representative
- Design team
- Building envelope consultant
- Blower door consultant



- **Knowledge dissemination**

- BTO's Commercial Building Integration Envelope Tech Team
- Share findings
 - Building Owners and Managers Association
 - Building energy consultants
 - Energy service companies (ESCOs)

Remaining Project Work: Envelope Retrofits

- **Complete ongoing retrofits**
 - Dundee theater, Omaha, NE
 - Madison municipal building, Madison, WI
 - Office building, Dallas, NC
- **Potential new retrofits**
 - Office building in Indiana
 - Will identify one more project
- **CSCEC (Chinese partner)**
 - Ongoing retrofit in Shenzhen
 - Will try to incorporate Dow's LIQUIDARMOR™

Dundee Theater
Omaha, NE



Madison Municipal Building
Madison, WI



Office in Dallas, NC



Approach: Air Sealing Technologies

Goal: Develop and evaluate the performance of new air sealing technologies

1. Focus on fluid applied technologies

- a. Less dependent on workmanship
- b. Fast installation

2. Dow's LIQUIDARMOR™ LT

- a. Install at $\geq -20^{\circ}\text{F}$
- b. Evaluate performance after exposure to 20°F to 80°F swings



Dow's LIQUIDARMOR LT

3. DuPont's Tyvek Fluid Applied WB+

- a. Rain resistance in <20 minutes
- b. Evaluate performance 20 minutes after installation



DuPont's Tyvek Fluid Applied WB+

Impact: Air Sealing Technologies

- **BTO 2030 goal: reduce energy use per ft² by 30% relative to 2010**
 - Air leakage is responsible for ~4% of energy consumed in the US
 - Current air sealing technologies are highly dependent on workmanship
- **Contributions from new air sealing technologies to BTO's goals**
 - Launch robust and easy-to-install air sealing technologies
 - LIQUIDARMOR™
 - 3 to 4 times faster to install than flashing tapes
 - Easily conforms to any shape
 - Tyvek Fluid Applied WB+
 - One-coat application
- **Validation of expected benefits**
 - CSCEC is retrofitting an office building in Shenzhen
 - May evaluate LIQUIDARMOR™ as flashing in window rough openings
 - Conduct air and water leakage tests

Progress/Remaining Work: Air Sealing Technologies

- Year 1

- Dow's LIQUIDARMOR™ LT

- Silicone-based liquid flashing that can be applied as low as -20°F
- Lab tests: performance after 20°F installation
- Launched in October 2016

- Dow's LIQUIDARMOR™ QS

- ~4 times faster drying time than LIQUIDARMOR™ CM
- Lab tests: performance on different substrates
- Launched in ~spring 2017

- Year 2 – Year 3

- Merger between Dow and DuPont slowed project
- Tasks from Year 2 will be conducted in Year 3
- Dow's LIQUIDARMOR™ LT
 - Evaluate performance after exposure to 20°F to 80°F swings
- DuPont's Tyvek Fluid Applied WB+
 - Evaluate performance 20 minutes after installation

Dow
LIQUIDARMOR™ LT



Dow
LIQUIDARMOR™ QS



Thank You

Oak Ridge National Laboratory
Diana Hun, Subprogram Manager for Building Envelopes
hunde@ornl.gov

REFERENCE SLIDES

Project Budget

Variances: none

Cost to Date: ~85%

Additional Funding: DOE's Advanced Manufacturing Office contributed \$240K to the 3D printed mold validation in the NYC building

Budget History

| 04/17 - 03/18 (past) | | 04/18 - 03/19 (current) | | 04/19 - 03/21 (planned) | |
|-------------------------|------------|----------------------------|------------|----------------------------|------------|
| DOE | Cost-share | DOE | Cost-share | DOE | Cost-share |
| \$1.08M | \$1.73M | \$535K | \$1.09M | \$1.6M | \$1.81M |

Project Plan and Schedule

| Deliverables/Milestones | ■ Deliverable/Milestone ■ Go/No Go ◆ Milestone met on time ◆ Missed milestone Delay approved by DOE | FY17 | | FY18 | |
|---|--|-----------------|----|------|----|
| | | Year 2 CERC BEE | | | |
| | | Q1 | Q2 | Q3 | Q4 |
| Task 1: Architectural Precast Insulated Concrete | | | | | |
| Subtask 1.3.1.1 – Develop lifting inserts for 1½ in.-thick wythes out of non-corroding composites. | | | | | |
| D.1.3.1.1.5 – Designed, developed, and tested an erection lifting insert with a 12,000 lbs. capacity. | | ◆ | | | |
| M.1.3.1.1.6 – Manufactured at least 25 samples of the 12,000 lbs. erection lifting inserts. | | | ◆ | | |
| D.1.3.1.1.7 – Designed, developed, and tested a stripping lifting insert with a 10,000 lbs. capacity. Go/No Go: ≥10,000 lbs. capacity. | | ■ | | | |
| M.1.3.1.1.8 – Manufactured at least 25 samples of the 10,000 lbs. stripping lifting inserts. | | | ■ | ■ | ◆ |
| Subtask 1.3.1.2 – Develop panel-to-building connectors inserts for 1 ½ in.-thick wythes out of non-corroding composites | | | | | |
| D.1.3.1.2.5 – Designed, developed, and tested a bolted-tieback connection with a 10,000 lbs. capacity. Go/No Go: ≥10,000 lbs. capacity. | | ■ | | | |
| M.1.3.1.2.6 – Manufactured at least 25 samples of the 10,000 lbs. bolted-tieback connectors. | | | ■ | ■ | ◆ |
| Subtask 1.3.2 – Develop high-performance concrete mixes that will allow for 1½ in.-thick wythes and reduce cement by 20 to 40% | | | | | |
| D.1.3.2.6.1 – Designed the most economical concrete mix for the inner wythe that reaches the required mechanical properties. | | ◆ | | | |
| M.1.3.2.6.2 – Designed economical concrete mix for the outer wythe with required mechanical properties. Go/No Go: <\$240/yd ³ <i>Estimates from first scale up was ~\$300/yd³. PCI did not reject the mix. ORNL will optimize the mix in Year 3.</i> | | ■ | | | |
| D.1.3.2.7.1 – Measured the baseline length change of mortars made with inner wythe mix, and confirmed acceptability with the PCI. | | | | ◆ | |
| D.1.3.2.7.2 – Measured the baseline length change of mortars made with outer wythe mix, and confirmed acceptability with the PCI. | | | ■ | ■ | ◆ |
| M.1.3.2.8 – Determined the max amount of supplementary cementitious materials while achieving the required mechanical properties. | | | | ■ | ◆ |
| D.1.3.2.9 – Go/No Go: Verified that 1 ½ in.-thick specimens can achieve a flexural strength ≥600 psi at 12 hours. | | | | ■ | ◆ |
| Subtask 1.3.3 – Improve air and water tightness and reduce heat transfer thru panel joints. | | | | | |
| D1.3.3.1 – Developed test protocol to evaluate sealants and/or joint designs for precast panels. | | ◆ | | | |
| D1.3.3.2.1 – Evaluated the decrease in heat flow at panel joint due to a pre-compressed foam tape. | | | ■ | | |
| D1.3.3.2.2 – Evaluated the decrease in heat flow at panel joint due to a 1.75"-deep pre-compressed foam tape and backer rod/sealant to each side of joint. | | | | ■ | |
| D1.3.3.2.3 – Conducted a cursory evaluation of a self-healing polymeric elastomer that ORNL recently developed. | | | | ■ | ◆ |
| Subtask 1.4 – Print molds for precast concrete. | | | | | |
| D1.4.3 – Selected two molds designs that will be printed and evaluated in Year 2. | | ◆ | | | |
| D1.4.4.1 – 3D printed 1 st mold. | | | ■ | | |
| D1.4.4.2 – 3D printed 2 nd mold. | | | | ■ | |
| D1.4.5 – Compared cost to manufacture 3D printed and traditional molds. Go/No Go: precaster feedback is that 3D printing is feasible. | | | | ■ | ◆ |
| Task 2: Retrofit of Commercial Building Envelopes | | | | | |
| D2.4.1 – Identified 3 to 4 potential retrofit projects. | | ◆ | | | |
| D2.4.2 – Measured the air leakage rate of two building envelopes before they are retrofitted. Go No/Go: Blower door test in one building. | | | ■ | | |
| D2.4.3 – Measured the air leakage rate of two building envelopes after they are retrofitted. | | | | ■ | ◆ |
| M2.4.4 – Estimated energy savings from the retrofit of two building envelopes. | | | | ■ | ◆ |
| Task 3: Air Sealing Technologies → delayed from Year 2 to Year 3 | | | | | |