

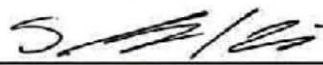

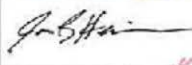


# Appendix F – Revised General Loading Procedures

	<b>AREVA Federal Services LLC</b>		
	<b>Engineering Information Record</b>		
<b>Document No.:</b>	<b>EIR-3016164</b>	<b>Rev. No.</b>	<b>001</b>
			<b>Page 1 of 53</b>
<b>Project No.:</b>	<b>00225.03.0050.01</b>	<b>Project Name:</b>	<b>DOE Atlas Railcar</b>
<b>Title:</b>	<b>Atlas Railcar General Loading Procedures</b>		
<b>Summary:</b>			
<p>This report provides a collection of general procedures that provide guidance for the loading of casks onto the transportation cradles (cradles), loading of cradles onto the Atlas railcar, and providing insight into the detailed design of the cask cradles and Atlas railcar.</p>			
<b>Contains Unverified Input / Assumptions:</b> Yes: <input type="checkbox"/> No: <input checked="" type="checkbox"/>			
	<b>Printed Name</b>	<b>Signature</b>	<b>Date</b>
<b>Preparer:</b>	M. Denton	 <small>Digitaly signed by: DENTON Mark DN: cn=AREVA GROUP, 2.5.4.48-190A87C163C410ED06190, c=DENTON Mark 0906.2017.04.24.12:1105 C400</small>	04/26/2017
<b>Checker:</b>	S. Klein		4/26/17
<b>Approver:</b>	D. Hillstrom		4/26/17
<b>Other:</b>	J. Heineman	 <small>Digitaly signed by: HEINEMAN Jason DN: cn=AREVA GROUP, 2.5.4.48-190A87C163C410ED06190, cn=AREVA Hillstrom Date: 2017.04.26.10:20:51 -0700</small>	04/26/2017

**AREVA Federal Services**  
**APR 26, 2017**  
**Records Management**

April 24, 2017

## Atlas Railcar General Loading Procedures

EIR-3016164-001

Prepared by: AREVA Federal Services LLC



### REVISION LOG

Rev.	Date	Affected Pages	Revision Description
000	August 1, 2016	All	Initial document release as approval by DOE
001	April 24, 2017	All	Issuance of DOE approved document incorporating DOE comments

### **DISCLAIMER**

This report was prepared as an account of work sponsored by an agency of the United States Government. Neither the United States Government nor any agency thereof, nor any of their employees, nor any of their contractors, subcontractors, or their employees, makes any warranty, express or implied, or assumes any legal liability or responsibility for the accuracy, completeness, or usefulness of any information, apparatus, product, or process disclosed, or represents that its use would not infringe privately owned rights. Reference herein to any specific commercial product, process, or service by trade name, trademark, manufacturer, or otherwise, does not necessarily constitute or imply its endorsement, recommendation, or favoring by the United States Government or any agency, contractor or subcontractor thereof. The views and opinions of authors expressed herein do not necessarily state or reflect those of the United States Government or any agency, contractor or subcontractor thereof.

**TABLE OF CONTENTS**

**Executive Summary** ..... v

**1.0 Introduction & Overview** ..... 1

**2.0 Methodology** ..... 3

**3.0 Assumptions**..... 4

**4.0 Generic Loading Activities**..... 6

    4.1 *Receive Railcar and Prepare for Loading* ..... 7

    4.2 *Remove Empty Transportation Cradle from Railcar* ..... 7

    4.3 *Prepare Transportation Cradle for Loading* ..... 8

    4.4 *Load Cask onto Transportation Cradle* ..... 8

    4.5 *Prepare Cask for Transport*..... 9

    4.6 *Secure Cask to Transportation Cradle* ..... 9

    4.7 *Install Impact Limiters onto Cask* ..... 9

    4.8 *Install Personnel Barrier onto Transportation Cradle*..... 10

    4.9 *Install Loaded Transportation Cradle onto Railcar* ..... 10

    4.10 *Final Loading Activities*..... 10

**5.0 Ballast Requirements**..... 11

**6.0 References**..... 12

**Appendix A – General Loading Procedures**..... A-1

**A.1 Receive Railcar and Prepare for Loading** ..... A-2

**A.2 Remove Empty Transportation Cradle from Railcar** ..... A-3

**A.3 Prepare Transportation Cradle for Loading** ..... A-3

**A.4 Load Cask Onto Transportation Cradle** ..... A-5

**A.5 Prepare Cask For Transport** ..... A-7

**A.6 Secure Cask To Transportation Cradle**..... A-8

**A.7 Install Impact Limiters onto Cask**..... A-9

**A.8 Install Personnel Barrier onto Transportation Cradle** ..... A-10

**A.9 Install Loaded Transportation Cradle Onto Railcar** ..... A-11

**A.10 Final Loading Activities** ..... A-13

**Appendix B – Loading Procedure Applicability Matrix** ..... B-1

**Appendix C – Transportation Cradle Details** ..... C-1



## LIST OF FIGURES

FIGURE 4-1: LOADING ACTIVITIES.....	6
FIGURE C-1A: FAMILY 1 CRADLE FOR TN-32B, TN-40, AND TN-40HT CASKS.....	C-1
FIGURE C-1B: FAMILY 1 CRADLE WITH TN-40 CASK.....	C-2
FIGURE C-1C: FAMILY 1 CRADLE WITH TN-40 CASK READY FOR TRANSPORT.....	C-2
FIGURE C-2: FAMILY 1 CRADLE WITH HI-STAR 60 CASK.....	C-3
FIGURE C-3: FAMILY 1 CRADLE WITH HI-STAR HB CASK.....	C-3
FIGURE C-4: FAMILY 1 CRADLE WITH HI-STAR 100 CASK.....	C-4
FIGURE C-5: FAMILY 1 CRADLE WITH HI-STAR 180 CASK.....	C-4
FIGURE C-6: FAMILY 1 CRADLE WITH HI-STAR 190SL CASK.....	C-5
FIGURE C-7: FAMILY 1 CRADLE WITH HI-STAR 190XL CASK.....	C-5
FIGURE C-8A: FAMILY 2 CRADLE FOR TN-68 CASK.....	C-6
FIGURE C-8B: FAMILY 2 CRADLE WITH TN-68 CASK.....	C-7
FIGURE C-8C: FAMILY 2 CRADLE WITH TN-68 CASK AND PERSONNEL BARRIER.....	C-7
FIGURE C-9A: FAMILY 2 CRADLE FOR NAC-STC CASK.....	C-8
FIGURE C-9B: FAMILY 2 CRADLE FOR NAC-UMS CASK.....	C-8
FIGURE C-10A: FAMILY 2 CRADLE FOR MAGNATRAN CASK.....	C-9
FIGURE C-10B: FAMILY 2 CRADLE WITH MAGNATRAN CASK.....	C-10
FIGURE C-10C: FAMILY 2 CRADLE WITH MAGNATRAN CASK & PERSONNEL BARRIER.....	C-10
FIGURE C-11A: FAMILY 3 CRADLE FOR MP197 CASK.....	C-11
FIGURE C-11B: FAMILY 3 CRADLE WITH MP197 CASK.....	C-11
FIGURE C-12: FAMILY 3 CRADLE FOR MP197HB CASK.....	C-12
FIGURE C-13: FAMILY 3 CRADLE FOR TS125 CASK.....	C-12
FIGURE C-14A: FAMILY 4 CRADLE FOR MP187 CASK.....	C-13
FIGURE C-14B: FAMILY 4 CRADLE WITH MP187 CASK.....	C-13
FIGURE C-15: CRADLE ATTACHMENT DETAILS.....	C-14
FIGURE C-16: SECUREMENT PIN RETENTION FEATURES.....	C-15
FIGURE C-17: PIN LOADING TRAY INSTALLED.....	C-15
FIGURE C-18: PIN LOADING TRAY WITH PIN RETRACTED.....	C-16
FIGURE C-19: ATLAS RAILCAR BALLAST WEIGHTS.....	C-17

**LIST OF TABLES**

TABLE 1-1: CASKS AND TRANSPORTATION CRADLES ..... 1  
TABLE 3-1: INITIAL CONFIGURATION OF CASKS ..... 5

### LIST OF ACRONYMS

AAR	Association of American Railroads
ALARA	As Low As Reasonably Achievable
CFR	Code of Federal Regulations
CoC	Certificate of Compliance
DOE	Department of Energy
HLRM	High-Level Radioactive Material
SAR	Safety Analysis Report
USNRC	U.S. Nuclear Regulatory Commission



## EXECUTIVE SUMMARY

This report, Atlas Railcar General Loading Procedures, fulfills the Phase 1 deliverable of DOE Contract DE-NE-0008390, Part I, Section C related to General Loading Procedures. These procedures include how to load each of the casks in Attachment A of the contract onto the Atlas railcar, including whether the impact limiters would be attached to the cask before or after the cask is secured to the railcar.

The purpose of this report is not to replace any detailed site-specific or cask-specific loading procedures. Its purpose is to inform the railcar and cask/cradle designers of the strength and versatility needed to accommodate the casks listed in Table 1-1.

This report provides a collection of general procedures that provide guidance for the loading of casks onto the transportation cradles and also the loading of cradles onto the railcar. Whenever possible, the procedures are provided in a general sense and apply to all of the Attachment A casks and cradles. When relevant design differences exist, specific subsections are included that may apply to a particular family of cradles or casks. There are a total of 17 unique casks and four cradle designs covered by this report, with each of the casks being assigned to a particular cradle design.

*It should be noted that these general loading procedures are based on conceptual designs of the cradles and Atlas railcar, with specific instructions, diagrams, figures and tables subject to change during final design and fabrication. Also, the loading procedures are intended as a guide to support the development of site-specific loading procedures; therefore, they do not include specific site requirements, inspection requirements, license review requirements, or necessary transport notifications; these items will need to be developed by the specific cask/cradle/Atlas railcar user(s) having responsibility for each subject area at each location where the cask/cradle/Atlas railcar are used.*

**1.0 INTRODUCTION & OVERVIEW**

This report, Atlas Railcar General Loading Procedures, fulfills the Phase 1 deliverable of DOE Contract DE-NE-0008390, Part I, Section C related to General Loading Procedures. These procedures include how to load each of the casks in Attachment A of the contract onto the Atlas railcar (hereafter referred to as railcar), including which casks can be up/down-ended on top of the railcar and whether the impact limiters would be attached to the cask before or after the cask is secured to the railcar.

This report provides a collection of general procedures that provide guidance for the loading of casks onto the transportation cradles (hereafter referred to as cradles) and also the loading of cradles onto the railcar. Whenever possible, the procedures are provided in a general sense and they apply to all of the casks and cradles. When relevant design differences exist, specific subsections are included that may apply to a particular family of cradles or casks. There are a total of 17 unique casks and four cradle family designs covered by this report, with each of the casks being assigned to a particular cradle family design. The casks and cradles covered by this report are listed in Table 1-1.

**TABLE 1-1: CASKS AND TRANSPORTATION CRADLES**

Cask Model	Cask Manufacturer	Cradle Family	Cradle Features
TN-32B	AREVA TN	Family 1	1) Lower saddles to support cask 2) Metal straps to secure cask to cradle 3) End stops to resist longitudinal forces
TN-40			
TN-40HT			
HI-STAR 60	Holtec International		
HI-STAR HB			
HI-STAR 100			
HI-STAR 180			
HI-STAR 190SL			
HI-STAR 190XL			
TN-68	AREVA TN		
NAC-STC	NAC International		
NAC-UMS			
MAGNATRAM			
MP197	AREVA TN	Family 3	1) Lower saddles to support cask 2) Metal straps to secure cask to cradle 3) Shear blocks on railcar deck and shear key in center of cask to resist longitudinal forces
MP197HB	EnergySolutions		
FuelSolutions TS125			
MP187	AREVA TN	Family 4	1) Lower saddles to support cask 2) Upper saddles to secure cask to cradle 3) Shear blocks on railcar deck and shear key in center of cask to resist longitudinal forces

Section 2.0 provides a discussion of the methodology used to generate the general loading procedures and also provides a description on the layout of the procedures that are found in Appendix A. Section 3.0 contains the related assumptions that were made when developing these general loading procedures. Section 4.0 includes the generic activities required for loading casks onto the railcar, the order in which these are typically performed, and other activities the procedures are applicable to. Also included in this section is discussion on what casks can be up/down-ended on top of the railcar and whether the impact limiters would be attached to the cask before or after the cask is secured to the railcar. Section 5.0 includes discussion on when an Atlas railcar requires the use of ballast weights and presents the steps necessary to install the ballast. References used throughout this report are included in Section 6.0.

Appendix A includes the general loading procedures applicable to the various casks and cradles and is structured so the steps related to individual casks can easily be extracted for use in a standalone procedure. To assist in this, Appendix B provides a matrix showing what sections of Appendix A are related to which casks. Appendix C includes a collection of figures representing the railcar and cradle conceptual designs.

Railroad related operations are not described in this report, except for high-level activities. Specific activities and associated requirements will be dictated by the railroad and/or site responsible personnel. Any terminology used in this report, related to rail operations, is not intended to direct railroad operations.

In addition to the railcar, cask, and cradle hardware, it is recommended that the consist have provisions to transport various ancillary equipment and spare parts. While standard tools, rigging, and materials can be obtained at the operation sites, the following ancillary equipment and spare parts are considered specialized and should be transported to the cask/cradle/railcar loading and unloading site:

- Jacks and tie-down devices to stabilize and secure the railcar deck during loading/unloading operations (specifications of jacks and tie-down devices to be generated by railcar designer )
- Wheel chocks to prevent railcar movement once placed
- Pin loading tray(s) – may change during final design of cradles
- Loaded-cradle lifting devices (for Family 3 cradles) – may change during final design of cradles
- Spare pins for cradle connections – may change during final design of cradles
- Spare pins for end stop connections – may change during final design of cradles



## 2.0 METHODOLOGY

The general loading procedures found in Appendix A were generated based on information found in Chapter 7 of the applicable Safety Analysis Reports ([1] through [12]), as well as design details found on the conceptual design drawings for the cradles ([13] through [18]). These procedures, which are considered to be general in nature, are not at a level of detail to perform any of the covered activities. As such, prior to conducting loading operations, the procedures provided in Appendix A should be used as one of many inputs to site-specific and cask-specific operating procedures.

The general loading procedures presented in this report only cover the activities directly related to the railcar and cradle operations. The procedures contained in this report do not address the following activities:

- Loading contents into the cask and preparing the cask for transport
- Performing any required radiation, contamination, or temperature surveys
- Performing any necessary inspections, whether they are related to the cask, cradle, or railcar
- Preparing or installing any required hazard communication, such as shipping papers, placards, markings, and labels
- Installing any security, positional, or performance monitoring devices, that may be required, onto the cask, cradle, or railcar

To minimize repetition across the casks, the loading procedure steps were consolidated whenever possible to apply to multiple casks and cradles. There are three levels of procedural steps included in Appendix A: steps applicable to every cask and every cradle; steps applicable to every cask within a particular cradle family; and steps applicable to individual casks. To extract loading procedures related to a particular cask, Appendix B should be utilized to guide the reader as to the applicable sections of Appendix A.

The initial configuration of equipment (casks, cradles, and the railcar) will likely be different in a number of cases, depending on the site and shipment constraints. Some of the casks are stored at the sites in a horizontal orientation, which will not necessarily require down-ending prior to loading the railcar, and some casks are stored vertically. Some of the casks will be fully prepared for shipment prior to arrival of the railcar, and other cases will involve receiving an empty cask on the railcar followed by on-site loading of the cask, prior to loading of the railcar. In other cases where a cask storage site is not rail served, heavy haul truck may be required from the site to the railcar. The methodology used in developing Appendix A was to provide a general collection of procedures that can be used in multiple scenarios. An example of this is that there are no steps for loading an empty cask onto the railcar, as the procedures for loading a full cask can be used for that activity, with minor alterations. Likewise, steps for unloading a full cask from the railcar are not included as they are basically the reverse order of the loading steps. The procedures provided in Appendix A are general in nature and will need to be expanded upon by the individual sites prior to planning for actual operations.

### 3.0 ASSUMPTIONS

The procedures within this report were developed based on the following assumptions:

- 1) The casks have previously been loaded, closed, and prepared for transportation in compliance with the appropriate USNRC Certificate of Compliance (CoC) prior to the railcar arrival. This includes, but may not be limited to: verification that the contents are allowable, the appropriate containment boundary leak test has been performed, the cask has been decontaminated to appropriate levels, and all regulatory markings and labels are present on the cask.
- 2) The TN-32B and TN-40HT cask Safety Analysis Reports (SAR), once they are issued, will align with the current TN-40 SAR [1]. While these casks are not yet certified under 10 CFR Part 71, they are very similar to the TN-40 cask.
- 3) The final MAGNATRAM SAR will not change significantly from the current version [9]. This cask is not yet certified under 10 CFR Part 71.
- 4) The final HI-STAR 190SL and 190XL SAR will not change significantly from the current draft version [5]. These casks are not yet certified under 10 CFR Part 71.

The procedures in Appendix A are based on the following assumed initial configuration of the equipment:

- a) The railcar arrives at the site with all necessary cradle hardware installed in the approved configuration. In addition, no cask is present on the railcar upon its arrival, nor is any ballast included.
- b) The cask had previously been loaded, closed, and prepared for transportation in compliance with the appropriate USNRC CoC prior to the railcar arrival.
- c) The cask is oriented as listed in Table 3-1. These initial configurations are based on a review of the associated SARs and the typical orientation described in Chapter 7 at the start of the Preparation for Transport steps.

**TABLE 3-1: INITIAL CONFIGURATION OF CASKS**

Cradle Family	Cask Model	Starting Configuration	Source / Basis
Family 1	TN-32B	Loaded cask is horizontal in a site-provided up-/down-ending device	The SAR discusses an up-ending/down-ending frame that is separate from the cradle [1]
	TN-40		
	TN-40HT		
	HI-STAR 60	Loaded cask is vertical on a concrete pad	Information received suggests that the cask is to be down-ended on the cradle [20] <sup>1</sup>
	HI-STAR HB	Loaded cask is horizontal in a site-provided up/down-ending device	Previous experience with the HI-STAR 100 included using a up/down-ending frame that was separate from the cradle.
	HI-STAR 100		
	HI-STAR 180	Loaded cask is vertical on a concrete pad	Information received suggests that the cask is to be down-ended on the cradle [20] <sup>1</sup>
	HI-STAR 190SL	Loaded cask is horizontal in a site-provided up/down-ending device	The SAR indicates that the cask is down-ended prior to being placed on the transport vehicle [5] <sup>2</sup>
HI-STAR 190XL			
Family 2	TN-68	Loaded cask is vertical on a concrete pad	The SARs state that the cask is down-ended on the cradle [6], [7], [8], [9] <sup>1</sup>
	NAC-STC		
	NAC-UMS		
	MAGNATRAM		
Family 3	MP197	Loaded cask is horizontal on a site-provided transfer trailer	The SAR states that the cask is down-ended on the on-site transfer trailer and is then to be lifted horizontally and placed onto the transport cradle [10]
	MP197HB		
	TS125	1) Loaded cask is horizontal on a site-provided transfer trailer, OR 2) Loaded cask is vertical on a concrete pad	The SAR presents the 2 options shown for how the cask is oriented prior to loading the cradle [11] <sup>1</sup>
Family 4	MP187	Loaded cask is horizontal on a site-provided transfer trailer	The SAR states that the cask is horizontal on the on-site transfer trailer [12]

These initial configurations are assumed for convenience in this report. If any cask exists at any site in a different configuration, the site would have the capability to up-end it or down-end it, as necessary, and to place it on the Atlas railcar.

<sup>1</sup> The railcar has been designed to permit up/down-ending of these casks while on top of the railcar deck, as long as jacks are deployed to unload the railcar suspension.

<sup>2</sup> Due to their weight, the HI-STAR 190SL/XL casks cannot be up/down-ended while on top of the railcar deck.

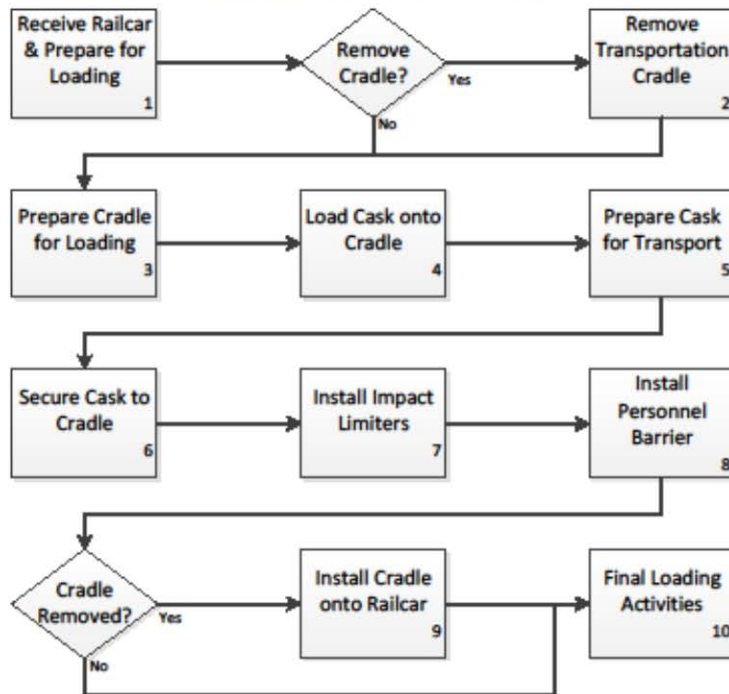


#### 4.0 GENERIC LOADING ACTIVITIES

The general procedures in this report describe the railcar loading cycle which begins with a railcar arriving on site and ends once the railcar has been loaded with the cask and prepared for transport. The railcar arrives on site with the appropriate cradle, but without a cask. Operations to perform activities not specifically included in this report, such as how to unload the cask from the railcar can be inferred by reversing the applicable steps. Unless otherwise stated (reference Table 3-1 and related footnotes), the activities may take place on the railcar or on the ground, depending on whether the cradle had previously been removed and is no longer on the railcar.

A flowchart of the loading activities covered by this report is provided in Figure 4-1 and further discussion of the various loading activities is provided in subsequent sections. Procedures for conducting these activities are contained in Appendix A.

FIGURE 4-1: LOADING ACTIVITIES



#### 4.1 Receive Railcar and Prepare for Loading

The loading sequence begins with the arrival of an empty railcar at the site with all necessary cradle hardware installed in the approved configuration. While no cask is present on the railcar for this report, the set of activities would be the same if the railcar arrives at the site with an empty cask.

Steps involved in this section include:

- Placement of the railcar and installing the necessary chocks, jacks, and chains. Depending on the site requirements and the operations to be performed on top of the railcar, not all of these activities will necessarily be required. For example, if the cask is to be rotated on top of the railcar, then the jacks will need to be used as the railcar suspension is not designed to support the concentrated loading of a cask in the vertical orientation.
- Connecting, disconnecting, and removal of (longitudinal) end stops (applicable only to Family 1 cradles).

#### 4.2 Remove Empty Transportation Cradle from Railcar

This activity is optional, depending on site needs. The operating procedures in the safety analysis reports are written with the assumption that the cask is loaded into the cradle while it is secured to the railcar. This is true for all of the casks covered in this report. While this appears to be the original intent when the safety analysis reports were written, it should be recognized that it may not be the optimal method, nor does it appear to be required by the applicable regulations.

Depending on site characteristics and the specific cask, there may be limitations to how high a cask can be lifted without impact limiters. The maximum height that a cask can be lifted without impact limiters is typically defined in the facility-specific safety analysis report. Exceeding the defined height would likely require expensive engineering controls to be implemented. There would likely be additional safety considerations and controls involved in performing loading activities on top of the railcar. Considering the added complexities, it is felt that the optimal location to load the cask into the cradle and install the impact limiters is on the ground.

Each of the cradle designs in this report include features for lifting a fully assembled package (cradle, horizontal cask, impact limiters, and personnel barrier), which allows for operational flexibility. The loading procedures in Appendix A include steps for loading the cask onto the cradle in both scenarios: on the ground or while the cradle is secured to the railcar. Reference Table 3-1 for casks that can be up/down-ended on the railcar.

With minor modifications, the procedures for this activity can also be utilized for other operations involving removal of the cradle from the railcar including: trans-loading between railcars and trailers or when unloading a loaded cask at a destination site. When using these procedures for those purposes, it should be emphasized that the Family 3 cradles have separate lifting lug locations depending on if the cradle is empty or loaded with a cask.

Steps involved in this section, which apply to each and every cask and cradle covered in this report, include:

- Disconnecting the cradle from the railcar;
- Rigging to and lifting an empty cradle from the railcar onto the ground for loading a cask.



### 4.3 Prepare Transportation Cradle for Loading

The activities in this section pertain to configuring the cradle to accept a cask. The generic loading activity listings provided in this section can also be utilized, with modifications, for operations involving the unloading of a cradle with a cask installed on it. While most of the steps would be applicable, some such as those related to the impact limiter tie rods would not be applicable for unloading scenarios.

Steps involved in this section include:

- Removing personnel barrier and cask tie-down straps from the cradle
- Removing trunnion capture covers (applicable only to certain cradles)
- Positioning lower impact limiter tie rods into the cradle (applicable only to certain cradles)
- Attaching separate down-ending tower to the cradle (applicable only to certain cradles).

### 4.4 Load Cask onto Transportation Cradle

The activities in this section pertain to placing the cask into the cradle, whether the cradle is on the ground or on top of the railcar. For some casks starting in the horizontal orientation, this involves lifting the cask and lowering it into the cradle. For the other casks, these activities include lifting a vertically oriented cask, locating the lower trunnions in either the cradle or the down-ending tower, and then rotating the cask to where it is resting in the cradle. The casks that can be down-ended onto their cradle include: the HI-STAR 60, HI-STAR 180, TN-68, NAC-STC, NAC-UMS, MAGNATRAN, and the TS125. In all of these cases, there is no restriction as to where the down-ending takes place, although when down-ending activities are performed on top of the railcar, the railcar deck must be stabilized by means of jacks and not supported by the suspension system.

The steps included in Section 4.3 must be performed prior to beginning the below listed activities. The activities listed within this section could also be used to develop cask unloading procedures; although, the steps would be reversed.

Steps involved in this section include:

- Attaching rigging between the crane and the cask
- Lifting the cask and transferring it over the cradle, whether the cradle is on the ground or on top of the railcar
- Removing the cask shear key plug (applicable only to certain casks)
- Removing the cask trunnions and installing trunnion plugs (applicable only to specific casks)
- Lowering the cask into the cradle
- Down-ending the cask into the cradle (Reference Table 3-1 as this is applicable only to specific casks)

#### 4.5 Prepare Cask for Transport

The activities in this section pertain to preparing the cask to receive impact limiters and to remove any items prior to transport. While some of these activities could be performed prior to placing the cask in the cradle, these are currently aligned with the SAR sequence of operations.

Steps involved in this section include:

- Removing the cask trunnions and installing trunnion plugs (applicable only to specific casks)
- Installing covers over the cask trunnions (applicable only to specific casks)
- Installing impact limiter spacers (applicable only to specific casks)
- Installing external fins onto the cask body (applicable only to specific casks)
- Installing trunnion capture covers (applicable only to specific casks)

#### 4.6 Secure Cask to Transportation Cradle

The activities in this section pertain to securing the cask to the cradle with metal tie-down straps.

Steps involved in this section include:

- Rigging and lifting/lowering the cask tie-down straps
- Securing the cask tie-down straps to the cradle

#### 4.7 Install Impact Limiters onto Cask

In all cases, it is expected that the impact limiters will be installed once the cask has been loaded onto the cradle. If unique scenarios arise at a site where impact limiters are to be installed onto the cask prior to loading the cask onto the cradle, procedures in Appendix A will need to be updated accordingly by the site. It is important to note that some sites and casks may require limited lift heights prior to installing the impact limiters, which will likely influence where the cradle is loaded. The maximum height that a cask can be lifted without impact limiters is typically defined in the site-specific safety analysis report. The designs of the railcar, the cradles, and the cradle attachment components are such that the impact limiters can be installed onto any of the casks while located on top of the railcar. The actual location of where they are installed however will be driven by where the cradle is located (on or off of the railcar).

While this report does not include procedures for removing the impact limiters from a cask, the procedures within this section could be utilized for such operations, although the steps would be reversed.

Steps involved in this section include:

- Preparations of the cask and/or impact limiters, for specific casks
- Rigging and lifting the impact limiters
- Placing the impact limiters onto the cask
- Securing the impact limiters to the cask

#### **4.8 Install Personnel Barrier onto Transportation Cradle**

The activities in this section pertain to installing the personnel barrier, which is part of the cradle. For some of the casks, this step is optional based on whether the dose and temperature surveys require the barrier. For other casks, this is required for all shipments. The installation of the personnel barrier must occur after the cask has been secured in the cradle.

Steps involved in this section include:

- Rigging and lifting the personnel barrier
- Placing the personnel barrier onto the cradle
- Securing the personnel barrier to the cradle

#### **4.9 Install Loaded Transportation Cradle onto Railcar**

If the cradle had been previously removed from the railcar (Section 4.2), then this activity is needed to lift a loaded cradle onto the railcar and secure it in place. The procedures for this activity, included in Appendix A, assume that the cask has already been installed and secured to the cradle and the impact limiters and personnel barrier have also been installed. This set of procedures can also be utilized for intermodal transfers, from (or to) a heavy-haul truck or barge to (or from) the Atlas railcar.

Steps involved in this section include:

- Rigging to and lifting a loaded cradle
- Placing the cradle onto the railcar
- Securing the cradle to the railcar by installing pins through the cradle frame and the mating railcar lugs.

#### **4.10 Final Loading Activities**

This section involves final loading activities that must be completed prior to transporting the loaded railcar. This section does not include other final activities, such as inspections, attaching placards and radiation surveys.

Steps involved in this section include:

- Rigging to and lifting the end stops (only applicable to Family 1 cradles)
- Placing the end stops onto the railcar (only applicable to Family 1 cradles)
- Securing the end stops to the railcar (only applicable to Family 1 cradles)
- Removing any devices used to position and stabilize the railcar deck



## 5.0 BALLAST REQUIREMENTS

When an empty Atlas railcar is included in an AAR Standard S-2043 compliant consist, a set of ballast weights will need to be included to increase the gross weight of the railcar. It has been shown through dynamic modeling that the ballast is needed to ensure the dynamic performance of the empty railcar satisfies the requirements found in AAR Standard S-2043 (See EIR-3018318, High Level Radioactive Material (HLRM) Prototype Railcars Phase 4, Phase 5 and Production Estimates and Schedules, Appendix B [21]).

When an empty Atlas railcar is being transported in general service (i.e. not connected to railcars carrying HLRM) it has been shown that the dynamic performance will meet the governing requirements for non-HLRM service, without the need to add ballast weights.

The ballast load design was developed to utilize the existing load securement features on the Atlas railcar. The ballast weights, shown in Figure C-19, are attached to the railcar using a set of securement pins and the end stop securement blocks, which are shown in Figures C-15 and C-16. The following steps describe how to secure the ballast weights to the Atlas railcar:

1. Clean all of the securement pins and inside surface of pin holes. After cleaning, coat the surfaces with nuclear grade grease such as Never Seez.
2. Connect rigging between a crane and the ballast main assembly segment to be installed
3. Lift and position the ballast main assembly segment directly over the top of the railcar
4. Lower the ballast main assembly segment onto the railcar, ensuring alignment with the connection pin holes in the end stop securement blocks
5. Loosen the pin retention plate securement bolts, rotate the pin retention plates 90 degrees, and retighten the securement bolts
6. Install the pin tray at the location to install a connection pin
7. Place the connection pin into the pin tray
8. Slide the pin into place through the railcar lugs and the ballast main assembly segment holes
9. Remove the pin tray
10. Loosen the pin retention plate securement bolt, rotate the pin retention plate down, and retighten the securement bolt
11. Repeat steps 6 through 10 for the other ballast main assembly segment connection pin
12. Repeat steps 2 through 11 for the three other ballast main assembly segments
13. Connect rigging between a crane and the ballast top assembly segment to be installed
14. Lift and position the ballast top assembly segment directly over the top of the railcar
15. Lower the ballast top assembly segment onto a pair of previously installed ballast main assemblies
16. Install the securement devices between the ballast main assemblies and the ballast top assembly
17. Repeat steps 13 through 16 for the second ballast top assembly



## 6.0 REFERENCES

- [1] AREVA TN, Docket Number 71-9313, *TN-40 Transportation Packaging Safety Analysis Report*, Rev. 16. It is assumed that this SAR also applies to the TN-32B and TN-40HT casks.
- [2] Holtec International, Docket Number 71-9336, *HI-STAR 60 Safety Analysis Report*, Rev. 2.
- [3] Holtec International, Docket Number 71-9261, *HI-STAR Safety Analysis Report*, Rev. 15. This SAR applies to the HI-STAR 100 and HI-STAR HB casks.
- [4] Holtec International, Docket Number 71-9261, *HI-STAR 180 Safety Analysis Report*, Rev. 6.
- [5] Holtec International, Docket Number 71-9373, *Safety Analysis Report on the HI-STAR 190 Package*, Rev. 0.C. This SAR applies to the HI-STAR 190SL and 190XL casks.
- [6] AREVA TN, Docket Number 71-9293, *TN-68 Packaging Safety Analysis Report*, Rev. 4.
- [7] NAC International, Docket Number 71-9235, *NAC-STC Safety Analysis Report*, Rev. 15.
- [8] NAC International, Docket Number 71-9270, *SAR-UMS® Universal Transport Cask Safety Analysis Report*, Rev. 2.
- [9] NAC International, Docket Number 71-9356, *MAGNATRAN Transport Cask Safety Analysis Report*, Rev. 12A.
- [10] AREVA TN, Docket Number 71-9302, *MP197 Transportation Packaging Safety Analysis Report*, Rev. 7. This SAR also applies to the MP197HB cask.
- [11] EnergySolutions, Docket Number 71-9276, *FuelSolutions™ TS125 Transportation Cask Safety Analysis Report*, Rev. 6.
- [12] AREVA TN, Docket Number 71-9255, *NUHOMS®-MP187 Multi-Purpose Cask Safety Analysis Report*, Rev. 17.
- [13] 3015137, latest revision. *Atlas Railcar Cradle Family 1 Conceptual Drawing*.
- [14] 3015277, latest revision. *Atlas Railcar Cradle Family 2 (TN-68) Conceptual Drawing*.
- [15] 3015138, latest revision. *Atlas Railcar Cradle Family 2, (NAC) Conceptual Drawing*.
- [16] 3015139, latest revision. *Atlas Railcar Cradle Family 3 Conceptual Drawing*.
- [17] 3015140, latest revision. *Atlas Railcar Cradle Family 4 Conceptual Drawing*.
- [18] 3015278, latest revision. *Atlas Railcar Cradle Attachment Components Conceptual Drawing*.
- [19] 1155-811, *200 Ton Flat Cask Car Drawing*.
- [20] AFS-16-0110, April 7, 2016. *Atlas HLRM Railcar Monthly Status Report for March 2016*.
- [21] EIR-3018318, latest revision. *High Level Radioactive Material (HLRM) Prototype Railcars Phase 4, Phase 5 and Production Estimates and Schedules*.

## **APPENDIX A – GENERAL LOADING PROCEDURES**

The general procedures provided in this appendix start with a railcar containing only an empty cradle (no cask) arriving at the site and end once the railcar has been loaded with the cask and prepared for transport. Any operations to unload the cask from the railcar can essentially be inferred by reversing the applicable steps.

Procedures related to railroad-specific operations and any inspections of the casks, cradles, and railcars are not included in this report.

To minimize repetition across the casks, the general loading procedure steps are consolidated whenever possible to apply to multiple casks and cradles. The three levels of procedural steps are:

- Steps applicable to every cask and every cradle covered in this report. These are listed under the A.x headings, where x = 1 through 10, depending on the activity.
- Steps applicable to every cask within a particular cradle family. These are listed under the A.x.y headings, where x = 1 through 10, depending on the activity and y = 1 through 4, depending on the cradle family.
- Steps applicable to individual casks. These are listed under the A.x.y.z headings, where x = 1 through 10, depending on the activity, y = 1 through 4, depending on the cradle family, and z = 1 through 3, depending on the particular cask.

Appendix B should be used to guide the reader as to which sections of Appendix A are applicable for the specific casks.

Appendix C includes figures that can help the reader understand the components being discussed in the following procedural steps.

### **CAUTION**

**Many of the operations are located near the cask and will result in increased worker dose. These activities should be controlled per ALARA practices. The dose rates near the lid and bottom of the cask are likely to be higher than near the cask body. The use of temporary shielding, specialized long-reach tools and reduced exposure times should be considered during the work planning stages.**

## **A.1 RECEIVE RAILCAR AND PREPARE FOR LOADING**

- 1) Position railcar in the loading location

### **NOTE**

The following methods to secure and stabilize the railcar may not be necessary for every site and set of activities, although they should be considered during the work planning stage.

- 2) Place wheel chocks against railcar wheels
- 3) Position vertical jacks under the railcar jacking pads and raise jacks until railcar suspension is unloaded and deck is level
- 4) Install tie-down devices between railcar tie-down lugs and ground and tighten to prevent movement
- 5) For Family 1 cradles, perform additional activities listed in A.1.1

### **A.1.1 Specific Procedures for Family 1 Cradles**

- 1) Remove devices from all end stop lifting holes that rendered them inoperable
- 2) Install lifting shackles to the end stop segment to be removed
- 3) Connect rigging between the crane and the end stop segment lifting shackles
- 4) Loosen the pin retention plate securement bolts, rotate the pin retention plates 90 degrees, and retighten the securement bolts
- 5) Install the pin tray at the location to remove a connection pin
- 6) Retract the pin into the pin tray
- 7) Remove the pin
- 8) Remove the pin tray
- 9) Loosen the pin retention plate securement bolt, rotate the pin retention plate down, and retighten the securement bolt
- 10) Repeat steps 5 through 9 for the other end stop pins
- 11) Lift end stop segment and remove from railcar
- 12) Repeat steps 2 through 11 for other end stop segments



## **A.2 REMOVE EMPTY TRANSPORTATION CRADLE FROM RAILCAR**

This activity is optional, depending on site needs.

- 1) Remove devices from cradle lifting lugs that rendered them inoperable
- 2) Install lifting shackles to the cradle lifting lugs
- 3) Connect rigging between the crane and the cradle lifting shackles
- 4) Loosen the pin retention plate securement bolts, rotate the pin retention plates 90 degrees, and retighten the securement bolts
- 5) Install the pin tray at the location to remove a connection pin
- 6) Retract the pin into the pin tray
- 7) Remove the pin
- 8) Remove the pin tray
- 9) Loosen the pin retention plate securement bolt, rotate the pin retention plate down, and retighten the securement bolt
- 10) Repeat steps 5 through 9 for other cradle pins
- 11) Lift cradle and remove from railcar
- 12) Place cradle on a level surface

## **A.3 PREPARE TRANSPORTATION CRADLE FOR LOADING**

- 1) Install personnel barrier lifting devices
- 2) Install cask tie-down strap lifting devices
- 3) Remove personnel barrier securement hardware from cradle
- 4) Connect rigging between the crane and the personnel barrier and remove it from cradle
- 5) Remove cask tie-down strap securement hardware from cradle
- 6) Connect rigging between the crane and the cask securement straps and remove them from cradle
- 7) For Family 1 cradles, perform additional activities listed in A.3.1
- 8) For Family 2 cradles, perform additional activities listed in A.3.2
- 9) For Family 3 cradles, perform additional activities listed in A.3.3

### **A.3.1 Specific Procedures for Family 1 Casks**

- 1) For TN-32B, TN-40, and TN-40HT casks, perform additional activities listed in A.3.1.1
- 2) For HI-STAR 60 and HI-STAR 180 casks, perform additional activities listed in A.3.1.2

**A.3.1.1 Unique Procedures for TN-32B, TN-40, and TN-40HT Casks**

- 1) Place 4 impact limiter lower tie rods into cradle slots
- 2) Place 2 lifting slings on top of tie rods, located under each of the cradle plates. These lifting straps are intended to be used later for lifting the loaded cradle (cradle, cask, impact limiters, and personnel barrier) and must be sized accordingly.

**A.3.1.2 Unique Procedures for HI-STAR 60 and HI-STAR 180 Casks**

- 1) Attach site-provided down-ending tower to cradle

**A.3.2 Specific Procedures for Family 2 Casks**

- 1) For TN-68 casks, perform additional activities listed in A.3.2.1
- 2) For NAC-STC and NAC-UMS casks, perform additional activities listed in A.3.2.2
- 3) For MAGNATRAN casks, perform additional activities listed in A.3.2.3

**A.3.2.1 Unique Procedures for TN-68 Casks**

- 1) Remove 2 trunnion capture covers
- 2) Place 4 impact limiter lower tie rods into cradle slots

**A.3.2.2 Unique Procedures for NAC-STC and NAC-UMS Casks**

- 1) Verify the front saddle bolts connecting the front saddle to the cradle are tight

**A.3.2.3 Unique Procedures for MAGNATRAN Casks**

- 1) Remove 2 trunnion capture covers
- 2) Verify the front saddle bolts connecting the front saddle to the cradle are tight

**A.3.3 Specific Procedures for Family 3 Casks**

- 1) For TS125 casks, perform additional activities listed in A.3.3.1

**A.3.3.1 Unique Procedures for TS125 Casks**

- 1) If the cask will be down-ended onto the cradle, then attach the site-provided down-ending tower to the cradle.

#### **A.4 LOAD CASK ONTO TRANSPORTATION CRADLE**

- 1) For Family 1 cradles, perform activities listed in A.4.1
- 2) For Family 2 cradles, perform activities listed in A.4.2
- 3) For Family 3 cradles, perform activities listed in A.4.3
- 4) For Family 4 cradles, perform activities listed in A.4.4

##### **CAUTION**

This activity involves hands-on work near higher dose areas of the cask

##### **NOTE**

Prior to lifting a cask without impact limiters, the maximum lift needs to be determined. This height will differ between casks and may even be different between sites using the same cask. Engineering controls, such as crash pads and physical lifting limitations, may need to be implemented prior to performing the lift.

#### **A.4.1 Specific Procedures for Family 1 Casks**

- 1) For TN-32B, TN-40, and TN-40HT casks, perform activities listed in A.4.1.1
- 2) For HI-STAR 60 and HI-STAR 180 casks, perform activities listed in A.4.1.2
- 3) For HI-STAR HB, HI-STAR 100, HI-STAR 190SL, and HI-STAR 190XL casks, perform activities listed in A.4.1.3

##### **A.4.1.1 Unique Procedures for TN-32B, TN-40, and TN-40HT Casks**

- 1) Attach crane with a spreader bar and slings to cask body
- 2) Lift cask and transfer over the top of the cradle
- 3) Lower cask into cradle, ensuring cask is centered in cradle

##### **A.4.1.2 Unique Procedures for HI-STAR 60 and HI-STAR 180 Casks**

- 1) Attach crane with a lifting yoke to cask upper trunnions
- 2) Lift cask and transfer over the top of the cradle
- 3) Lower the cask, verifying alignment of lower trunnions, to engage the lower trunnions
- 4) Down-end cask onto cradle
- 5) Remove down-ending tower from cradle

##### **A.4.1.3 Unique Procedures for HI-STAR HB, HI-STAR 100, HI-STAR 190SL, and HI-STAR 190XL Casks**

- 1) Attach crane with a spreader bar and slings to cask body
- 2) Lift cask and transfer over the top of the cradle
- 3) Lower cask into cradle, ensuring cask is centered in cradle



#### **A.4.2 Specific Procedures for Family 2 Casks**

- 1) Attach crane with a lifting yoke to cask upper trunnions
- 2) Lift cask and transfer over the top of the cradle
- 3) Down-end cask onto cradle

#### **A.4.3 Specific Procedures for Family 3 Casks**

- 1) For MP-197 and MP-197HB casks, perform activities listed in A.4.3.1
- 2) For TS125 casks, perform activities listed in A.4.3.2

##### **A.4.3.1 Unique Procedures for MP-197 and MP-197HB Casks**

- 1) Attach crane with a spreader bar and slings to cask upper and lower trunnions
- 2) Lift cask and transfer over the top of the cradle
- 3) Verify shear key plug has been removed from the cask
- 4) Lower cask into cradle, ensuring alignment of the shear key is maintained

##### **A.4.3.2 Unique Procedures for TS125 Casks**

- 1) If the cask is in the vertical orientation, proceed to step 6
- 2) Attach crane with a horizontal lifting fixture to cask upper trunnions (cables) and bottom cask body (sling)
- 3) Lift cask and position it directly over the top of the cradle
- 4) Verify shear key plug has been removed from the cask
- 5) Lower cask into cradle, ensuring alignment of the shear key is maintained

The following steps are only applicable if the cask is to be down-ended on the cradle:

- 6) Attach crane with a lifting yoke to cask upper trunnions
- 7) Lift cask and position it directly over the top of the cradle
- 8) Verify shear key plug has been removed from the cask
- 9) Down-end cask onto cradle
- 10) Remove down-ending tower from cradle

#### **A.4.4 Specific Procedures for Family 4 Casks**

- 1) Attach crane with a spreader bar and slings to Cask body
- 2) Lift cask and transfer over the top of the cradle
- 3) Verify shear key plug has been removed from the cask
- 4) Remove trunnions
- 5) Install trunnion hole plugs
- 6) Lower cask into cradle, ensuring alignment of the shear key

## **A.5 PREPARE CASK FOR TRANSPORT**

- 1) For Family 1 cradles, perform activities listed in A.5.1
- 2) For Family 2 cradles, perform activities listed in A.5.2
- 3) For Family 3 cradles, perform activities listed in A.5.3
- 4) There are no activities for Family 4 cradles in this section

### **CAUTION**

**This activity involves hands-on work near higher dose areas of the cask**

### **A.5.1 Specific Procedures for Family 1 Casks**

- 1) For TN-32B, TN-40, and TN-40HT casks, perform activities listed in A.5.1.1
- 2) For HI-STAR 180 casks, perform activities listed in A.5.1.2
- 3) For HI-STAR 190SL and HI-STAR 190XL casks, perform activities listed in A.5.1.3
- 4) There are no activities for the HI-STAR 60, HI-STAR HB, or HI-STAR 100 casks in this section

#### **A.5.1.1 Unique Procedures for TN-32B, TN-40, and TN-40HT Casks**

- 1) Install top impact limiter spacer

#### **A.5.1.2 Unique Procedures for HI-STAR 180 Casks**

- 1) Remove trunnions
- 2) Install trunnion hole plugs

#### **A.5.1.3 Unique Procedures for HI-STAR 190SL and HI-STAR 190XL Casks**

- 1) Install upper and lower radial spacers at the cask ends
- 2) Install trunnion covers

### **A.5.2 Specific Procedures for Family 2 Casks**

- 1) For MAGNATRAN casks, perform activities listed in A.5.2.1
- 2) There are no activities for the TN-68, NAC-STC, or NAC-UMS casks in this section

#### **A.5.2.1 Unique Procedures for MAGNATRAN Casks**

- 1) Remove upper trunnions
- 2) Install upper trunnion hole plugs

### **A.5.3 Specific Procedures for Family 3 Casks**

- 1) Remove trunnions
- 2) Install trunnion hole plugs
- 3) For MP-197HB casks, perform additional activities listed in A.5.3.1

#### **A.5.3.1 Unique Procedures for MP-197HB Casks**

- 1) Install external aluminum fins, if required

## **A.6 SECURE CASK TO TRANSPORTATION CRADLE**

- 1) Connect rigging between the crane and the cask tie-down strap
- 2) Transfer cask tie-down strap and locate it on the cradle
- 3) Install securement hardware and ensure tie-down strap is secure
- 4) Repeat steps 1 through 3 for other cask tie-down straps, if applicable
- 5) Remove cask tie-down strap lifting devices
- 6) For Family 1 cradles, perform additional activities listed in A.6.1
- 7) For Family 2 cradles, perform additional activities listed in A.6.2

### **A.6.1 Specific Procedures for Family 1 Casks**

- 1) Move lifting strap ends to the top of the cask, ensuring they remain routed under the cradle plates

### **A.6.2 Specific Procedures for Family 2 Casks**

- 1) For TN-68 casks, perform additional activities listed in A.6.2.1
- 2) For MAGNATRAN casks, perform additional activities listed in A.6.2.2

#### **A.6.2.1 Unique Procedures for TN-68 Casks**

- 1) Install 2 trunnion capture covers and related securement hardware

#### **A.6.2.2 Unique Procedures for MAGNATRAN Casks**

- 1) Install 2 trunnion capture covers and related securement hardware

## **A.7 INSTALL IMPACT LIMITERS ONTO CASK**

- 1) For Family 2 cradles, first perform activities listed in A.7.2
- 2) Connect rigging between the crane and the impact limiter
- 3) Install impact limiter onto cask
- 4) Install impact limiter securement hardware
- 5) Disconnect rigging from impact limiter
- 6) Render impact limiter lifting lugs inoperable by installing a bolt, or similar method
- 7) Repeat steps 2 through 6 for other impact limiter
- 8) For Family 1 cradles, perform additional activities listed in A.7.1
- 9) For Family 2 cradles, perform additional activities listed in A.7.2

### **A.7.1 Specific Procedures for Family 1 Casks**

- 1) For TN-32B, TN-40, TN-40HT casks, perform activities listed in A.7.1.1
- 2) For HI-STAR 180, HI-STAR 190SL, and HI-STAR 190XL casks, perform activities listed in A.7.1.2

#### **A.7.1.1 Unique Procedures for TN-32B, TN-40, TN-40HT Casks**

- 1) Install remaining impact limiter tie rods and securement hardware between impact limiters

#### **CAUTION**

To install the lower impact limiter tie rods and associated securement hardware, access between the cradle and cask will be required. The use of long reach tooling should be considered during this activity.

#### **A.7.1.2 Unique Procedures for HI-STAR 180, HI-STAR 190SL, and HI-STAR 190XL Casks**

- 1) Install at least 1 access tube cover on the top impact limiter

### **A.7.2 Specific Procedures for Family 2 Casks**

- 1) For TN-68 casks, perform activities listed in A.7.2.1
- 2) For NAC-UMS casks, perform activities listed in A.7.2.2

#### **A.7.2.1 Unique Procedures for TN-68 Casks**

- 1) Install shield ring onto cask, if required based on dose
- 2) Install front spacer onto cask
- 3) After performing step 7 in A.7, install remaining tie rods, and securement hardware, between impact limiters



#### **A.7.2.2 Unique Procedures for NAC-UMS Casks**

- 1) Install lower impact limiter positioner on the cask bottom

### **A.8 INSTALL PERSONNEL BARRIER ONTO TRANSPORTATION CRADLE**

- 1) For Family 1 cradles, perform additional activities listed in A.8.1
- 2) Connect rigging between the crane and the personnel barrier and position on the cradle
- 3) Install personnel barrier securement hardware
- 4) Remove personnel barrier lifting devices
- 5) Install padlocks on all personnel barrier access points

#### **A.8.1 Specific Procedures for Family 1 Casks**

- 1) For HI-STAR 60, HI-STAR 180, HI-STAR 190SL, and HI-STAR 190XL casks, perform additional activities listed in A.8.1.1

##### **A.8.1.1 Unique Procedures for HI-STAR 60, HI-STAR 180, HI-STAR 190SL, and HI-STAR 190XL Casks**

- 1) The use of a personnel barrier is optional for these casks, based on the measured dose rates and temperature surveys. The procedural steps in A.8 are not required in the event a personnel barrier for these casks is not required and/or will not be used.

## **A.9 INSTALL LOADED TRANSPORTATION CRADLE ONTO RAILCAR**

- 1) Clean all of the pins and inside surface of pin holes. After cleaning coat the surfaces with nuclear grade Never Seez.
- 2) Prior to performing the following steps, the cradle-specific activities must be performed:
  - a) For Family 1 cradles, first perform the activities listed in A.9.1
  - b) For Family 2 cradles, first perform the activities listed in A.9.2
  - c) For Family 3 cradles, first perform the activities listed in A.9.3
  - d) For Family 4 cradles, first perform the activities listed in A.9.4
- 3) Lift and position the cradle directly over the top of the railcar
- 4) Lower cradle onto railcar, ensuring alignment with connection pin holes

### **NOTE**

**For Family 1 cradles, the longitudinal location of the cradle on the railcar shall be such that the cradle connection pin holes are as close as possible to the center of the railcar lug pin slots. This will ensure that the connection pins do not transfer longitudinal loads during operations. The required tolerance from center will be determined as part of the cradle detail design.**

- 5) Loosen the pin retention plate securement bolts, rotate the pin retention plates 90 degrees, and retighten the securement bolts
- 6) Install the pin tray at the location to install a connection pin
- 7) Place the connection pin into the pin tray
- 8) Slide the pin into place through the railcar lugs and the cradle holes
- 9) Remove the pin tray
- 10) Loosen the pin retention plate securement bolt, rotate the pin retention plate down, and retighten the securement bolt
- 11) Repeat steps 6 through 10 for all other cradle pins
- 12) Disconnect rigging from cradle lifting devices
- 13) Disconnect cradle lifting shackles
- 14) Render cradle lifting lugs inoperable by installing a bolt, or similar method
- 15) For Family 3 cradles, step 3 listed in A.9.3.3 must be performed



#### **A.9.1 Specific Procedures for Family 1 Casks**

- 1) Connect crane with spreader bar to the cradle lifting slings, previously routed under cradle plates (around Cask body)

#### **A.9.2 Specific Procedures for Family 2 Casks**

- 1) Connect crane with spreader bar and slings to cradle lifting devices

#### **A.9.3 Specific Procedures for Family 3 Casks**

- 1) Install loaded-cradle lifting devices onto cradle

#### **NOTE**

**For Family 3 cradles, there are two sets of lifting devices. When lifting a loaded cradle, the removable set of lifting devices must be installed and used. When any lifting device is not in-use, they shall be rendered inoperable to avoid misuse.**

- 2) Connect crane with spreader bar and slings to loaded-cradle lifting devices
- 3) After performing steps 2 through 14 in A.9, remove the loaded-cradle lifting devices from the cradle

#### **A.9.4 Specific Procedures for Family 4 Casks**

- 1) Connect crane with spreader bar and slings to cradle lifting devices

## **A.10 FINAL LOADING ACTIVITIES**

- 1) Prior to performing the following steps, the cradle-specific activities must be performed:
  - a) For Family 1 cradles, first perform the activities listed in A.10.1
- 2) Remove the previously installed railcar securement devices, i.e., jacks, tie-down devices, etc.

### **A.10.1 Specific Procedures for Family 1 Casks**

- 1) Clean all of the pins and inside surface of pin holes. After cleaning coat the surfaces with nuclear grade Never Seez.
- 2) Secure lifting straps within the cradle so that they remain in place, but inoperable, during transit
- 3) Connect rigging between the crane and the end stop segment to be installed
- 4) Lift and position the end stop segment directly over the top of the railcar
- 5) Lower end stop onto railcar, ensuring alignment with connection pin holes
- 6) Loosen the pin retention plate securement bolts, rotate the pin retention plates 90 degrees, and retighten the securement bolts
- 7) Install the pin tray at the location to install a connection pin
- 8) Place the connection pin into the pin tray
- 9) Slide the pin into place through the railcar lugs and the end stop segment holes
- 10) Remove the pin tray
- 11) Loosen the pin retention plate securement bolt, rotate the pin retention plate down, and retighten the securement bolt
- 12) Repeat steps 7 through 11 for all other end stop connection pins
- 13) Remove lifting shackles from the end stop segment
- 14) Render end stop lifting holes inoperable by installing a bolt or similar method
- 15) Repeat steps 3 through 14 for other end stop segments
- 16) Install shims between end stops and impact limiters

EIR-3016164-001  
Page 34 of 53

**Intentionally Left Blank**



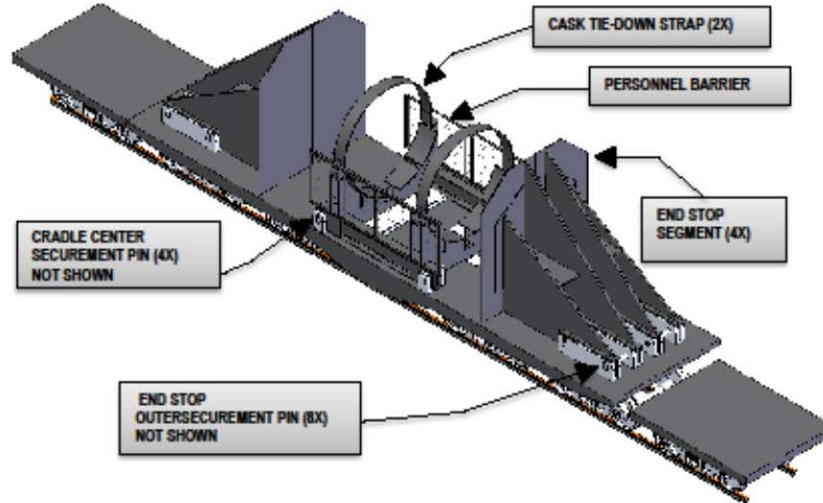
**APPENDIX B – LOADING PROCEDURE APPLICABILITY MATRIX**

Activity	Cask	TN-32B	TN-40	TN-40HT	HI-STAR 60	HI-STAR HB	HI-STAR 100	HI-STAR 180	HI-STAR 190SL	HI-STAR 190XL	TN-68	NAC-STC	NAC-UMS	MAGNA-TRAN	MP-197	MP-197HB	TS-125	MP-187
	Cradle Family	1										2				3		
1) Receive Railcar for Loading	A.1 & A.1.1	A.1 & A.1.1	A.1 & A.1.1	A.1 & A.1.1	A.1 & A.1.1	A.1 & A.1.1	A.1 & A.1.1	A.1 & A.1.1	A.1 & A.1.1	A.1 & A.1.1	A.1	A.1	A.1	A.1	A.1	A.1	A.1	A.1
2) Remove Transportation Cradle from Railcar	A.2	A.2	A.2	A.2	A.2	A.2	A.2	A.2	A.2	A.2	A.2	A.2	A.2	A.2	A.2	A.2	A.2	A.2
3) Prepare Transportation Cradle for Loading	A.3 & A.3.1.1	A.3 & A.3.1.1	A.3 & A.3.1.1	A.3 & A.3.1.2	A.3	A.3	A.3 & A.3.1.2	A.3	A.3	A.3	A.3 & A.3.2.1	A.3 & A.3.2.2	A.3 & A.3.2.2	A.3 & A.3.2.3	A.3	A.3	A.3 & A.3.3.1	A.3
4) Load Cask onto Transportation Cradle	A.4.1.1	A.4.1.1	A.4.1.1	A.4.1.2	A.4.1.3	A.4.1.3	A.4.1.2	A.4.1.3	A.4.1.3	A.4.1.3	A.4.2	A.4.2	A.4.2	A.4.2	A.4.3.1	A.4.3.1	A.4.3.2	A.4.4
5) Prepare Cask for Transport	A.5.1.1	A.5.1.1	A.5.1.1	No activities required	No activities required	No activities required	A.5.1.2	A.5.1.3	A.5.1.3	A.5.1.3	No activities required	No activities required	No activities required	A.5.2.1	A.5.3	A.5.3 & A.5.3.1	A.5.3	No activities required
6) Secure Cask to Transportation Cradle	A.6 & A.6.1	A.6 & A.6.1	A.6 & A.6.1	A.6 & A.6.1	A.6 & A.6.1	A.6 & A.6.1	A.6 & A.6.1	A.6 & A.6.1	A.6 & A.6.1	A.6 & A.6.1	A.6 & A.6.2.1	A.6	A.6	A.6 & A.6.2.2	A.6	A.6	A.6	A.6
7) Install Impact Limiters onto Cask	A.7 & A.7.1.1	A.7 & A.7.1.1	A.7 & A.7.1.1	A.7	A.7	A.7	A.7 & A.7.1.2	A.7 & A.7.1.2	A.7 & A.7.1.2	A.7 & A.7.1.2	A.7 & A.7.2.1	A.7	A.7 & A.7.2.2	A.7	A.7	A.7	A.7	A.7
8) Install Personnel Barrier onto Transportation Cradle	A.8	A.8	A.8	A.8 & A.8.1.1	A.8	A.8	A.8 & A.8.1.1	A.8 & A.8.1.1	A.8 & A.8.1.1	A.8 & A.8.1.1	A.8	A.8	A.8	A.8	A.8	A.8	A.8	A.8
9) Install Transportation Cradle onto Railcar	A.9 & A.9.1	A.9 & A.9.1	A.9 & A.9.1	A.9 & A.9.1	A.9 & A.9.1	A.9 & A.9.1	A.9 & A.9.1	A.9 & A.9.1	A.9 & A.9.1	A.9 & A.9.1	A.9 & A.9.2	A.9 & A.9.2	A.9 & A.9.2	A.9 & A.9.2	A.9 & A.9.3	A.9 & A.9.3	A.9 & A.9.3	A.9 & A.9.4
10) Prepare Final Loading Activities on Railcar for Transport	A.10 & A.10.1	A.10 & A.10.1	A.10 & A.10.1	A.10 & A.10.1	A.10 & A.10.1	A.10 & A.10.1	A.10 & A.10.1	A.10 & A.10.1	A.10 & A.10.1	A.10 & A.10.1	A.10	A.10	A.10	A.10	A.10	A.10	A.10	A.10

**Intentionally Left Blank**

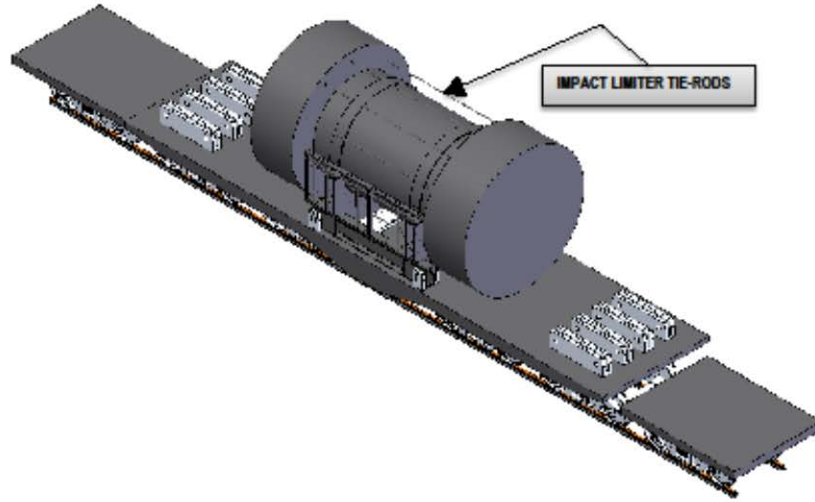
### APPENDIX C – TRANSPORTATION CRADLE DETAILS

FIGURE C-1A: FAMILY 1 CRADLE FOR TN-32B, TN-40, AND TN-40HT CASKS

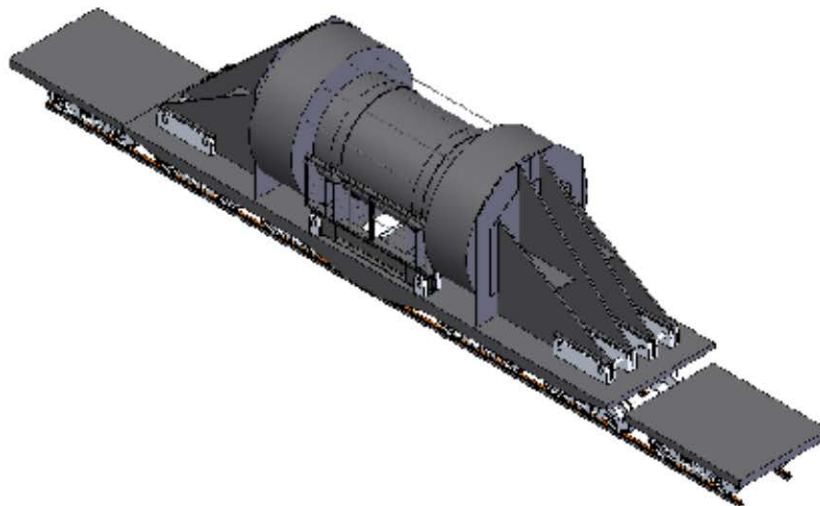




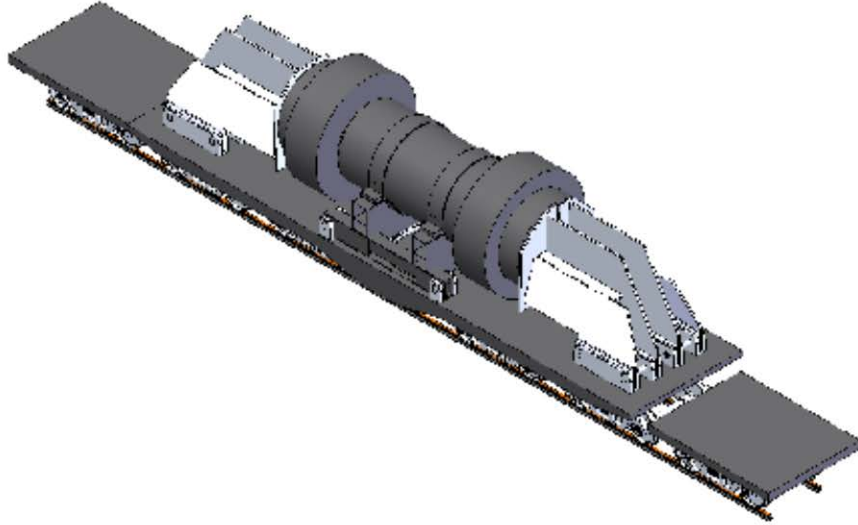
**FIGURE C-1B: FAMILY 1 CRADLE WITH TN-40 CASK**



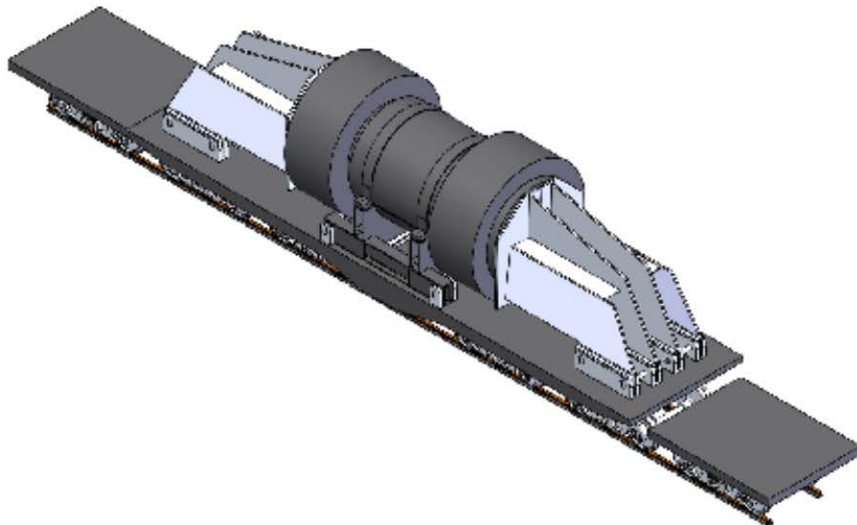
**FIGURE C-1C: FAMILY 1 CRADLE WITH TN-40 CASK READY FOR TRANSPORT**



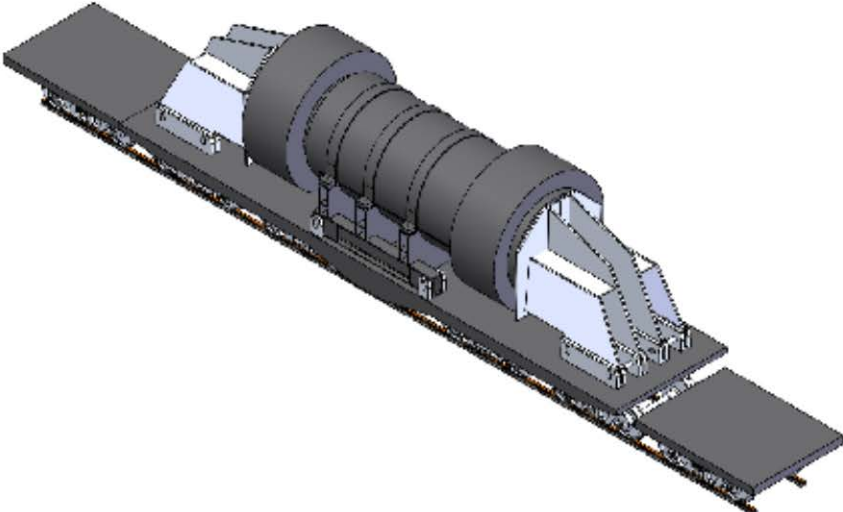
**FIGURE C-2: FAMILY 1 CRADLE WITH HI-STAR 60 CASK**



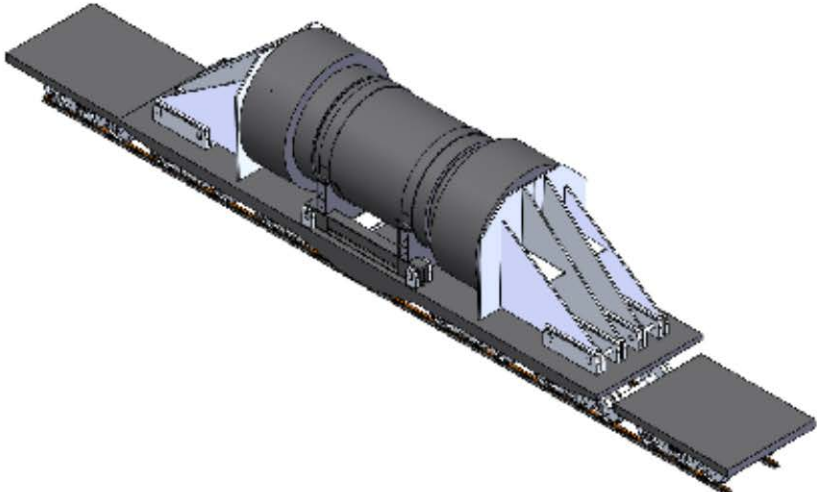
**FIGURE C-3: FAMILY 1 CRADLE WITH HI-STAR HB CASK**



**FIGURE C-4: FAMILY 1 CRADLE WITH HI-STAR 100 CASK**

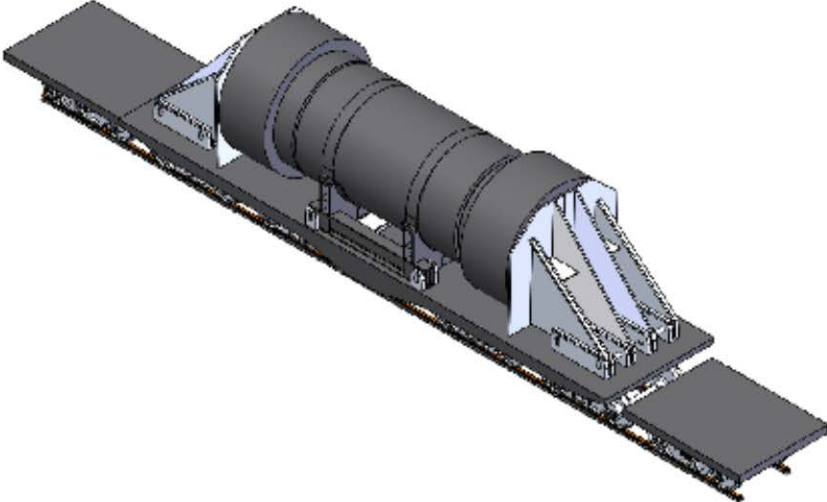


**FIGURE C-5: FAMILY 1 CRADLE WITH HI-STAR 180 CASK**

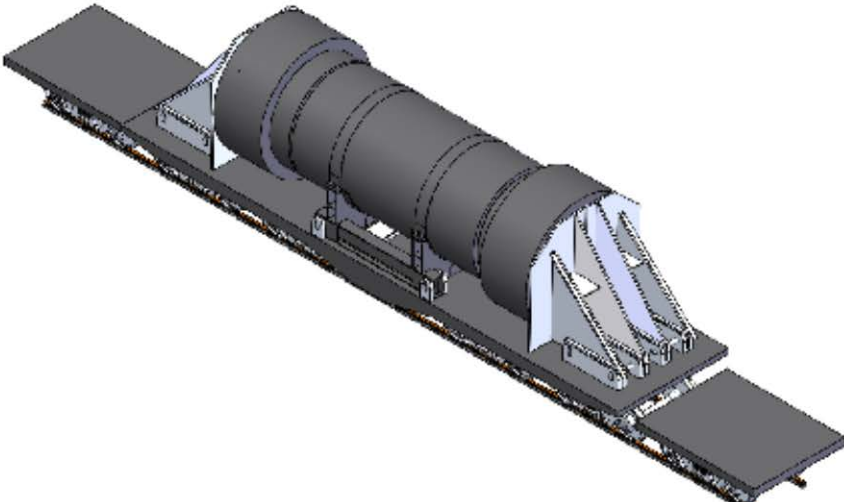




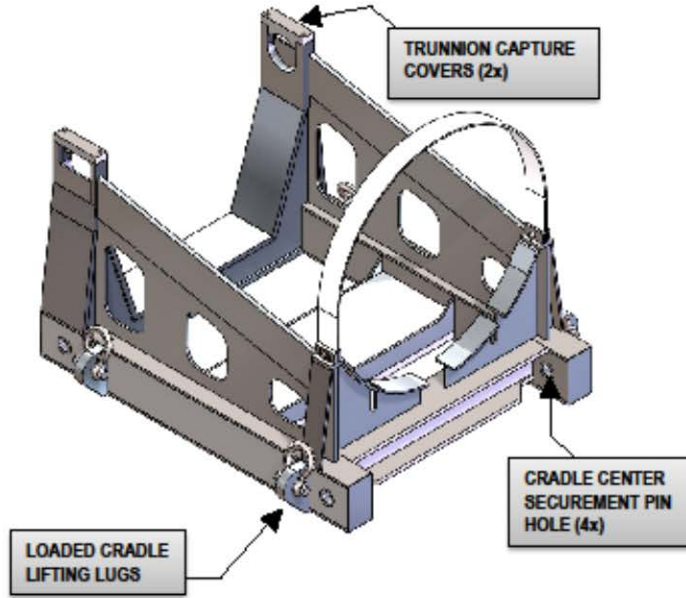
**FIGURE C-6: FAMILY 1 CRADLE WITH HI-STAR 190SL CASK**



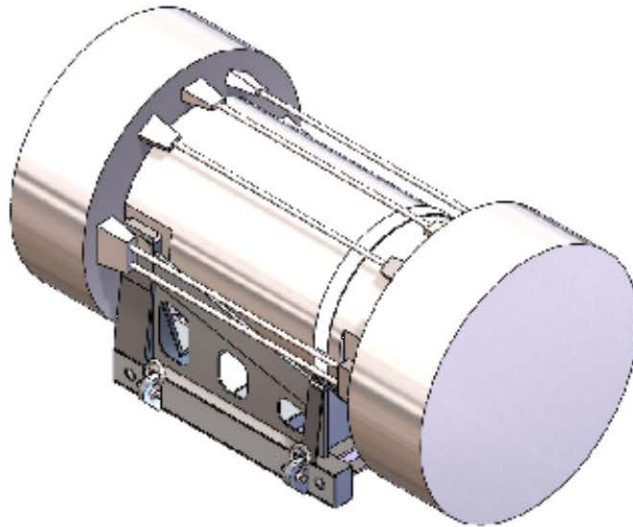
**FIGURE C-7: FAMILY 1 CRADLE WITH HI-STAR 190XL CASK**



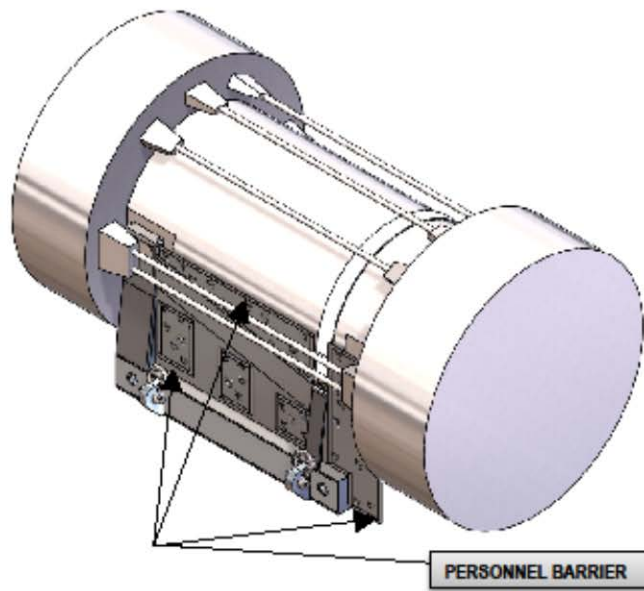
**FIGURE C-8A: FAMILY 2 CRADLE FOR TN-68 CASK**



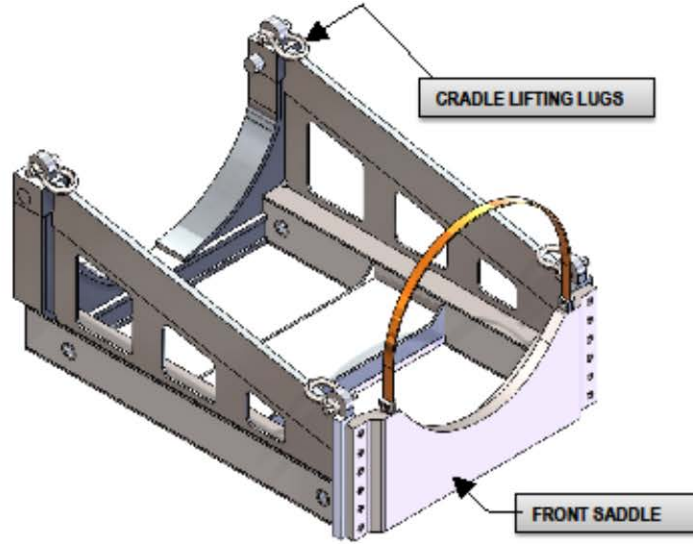
**FIGURE C-8B: FAMILY 2 CRADLE WITH TN-68 CASK**



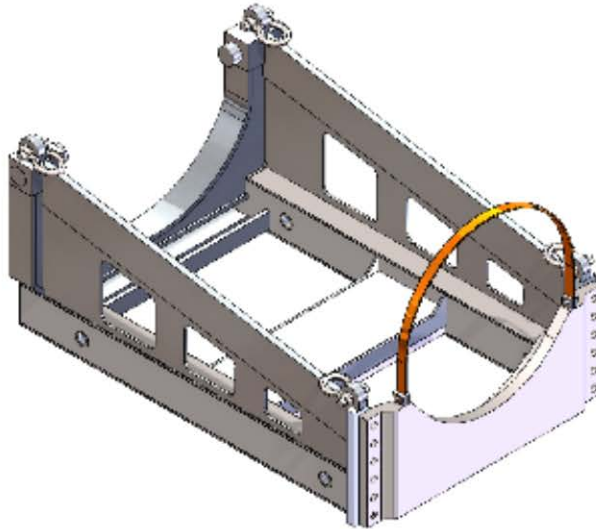
**FIGURE C-8C: FAMILY 2 CRADLE WITH TN-68 CASK AND PERSONNEL BARRIER**



**FIGURE C-9A: FAMILY 2 CRADLE FOR NAC-STC CASK**

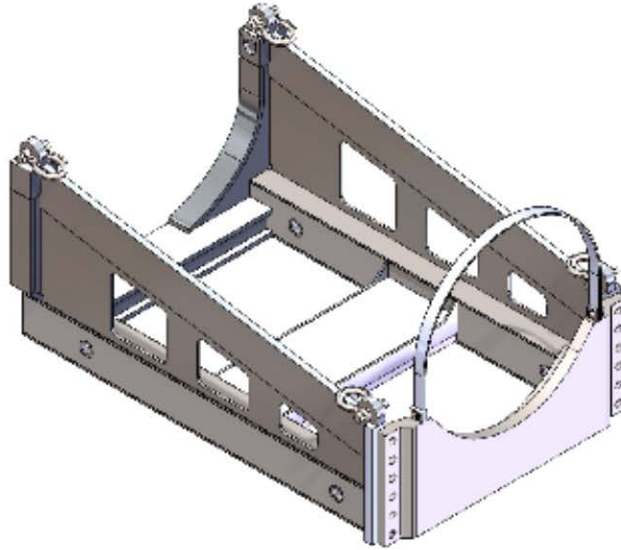


**FIGURE C-9B: FAMILY 2 CRADLE FOR NAC-UMS CASK**

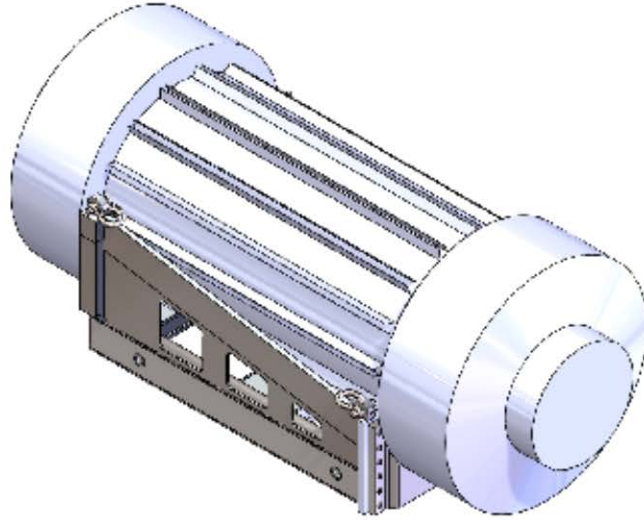




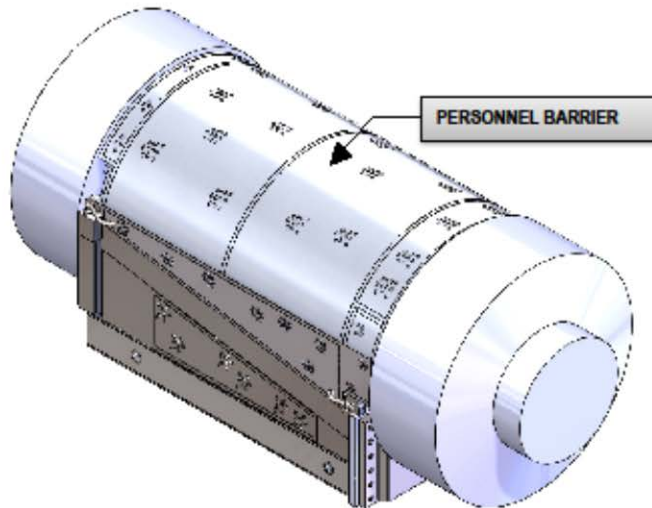
**FIGURE C-10A FAMILY 2 CRADLE FOR MAGNATRON CASK**



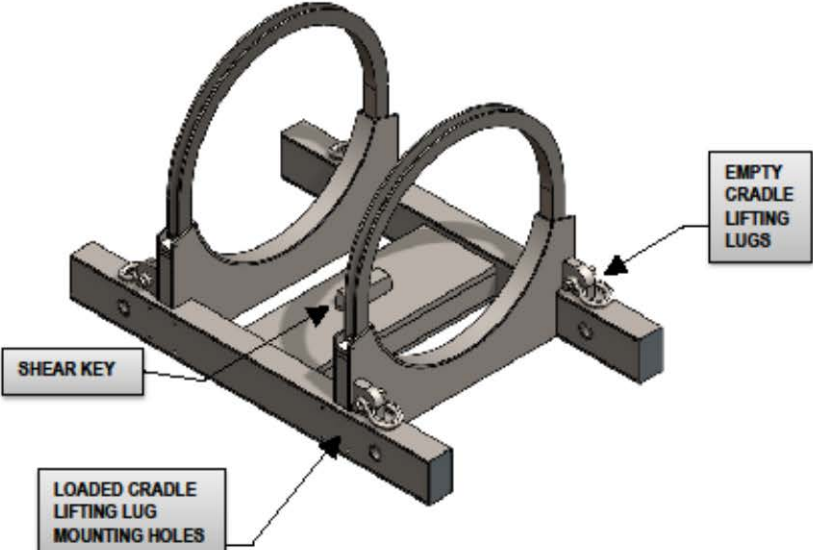
**FIGURE C-10B: FAMILY 2 CRADLE WITH MAGNATRAN CASK**



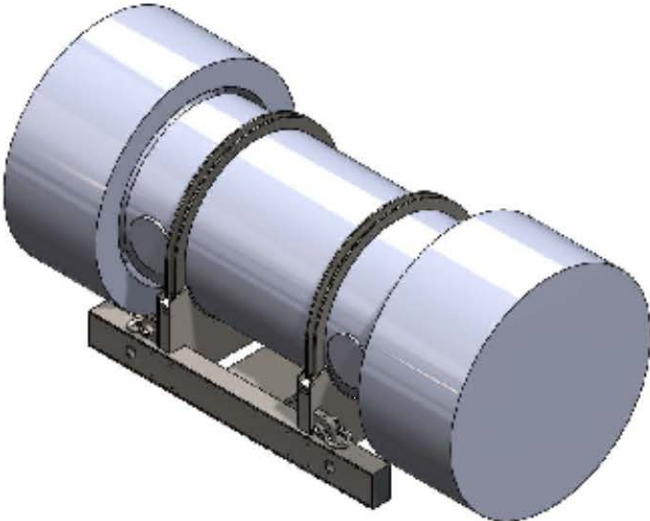
**FIGURE C-10C: FAMILY 2 CRADLE WITH MAGNATRAN CASK & PERSONNEL BARRIER**



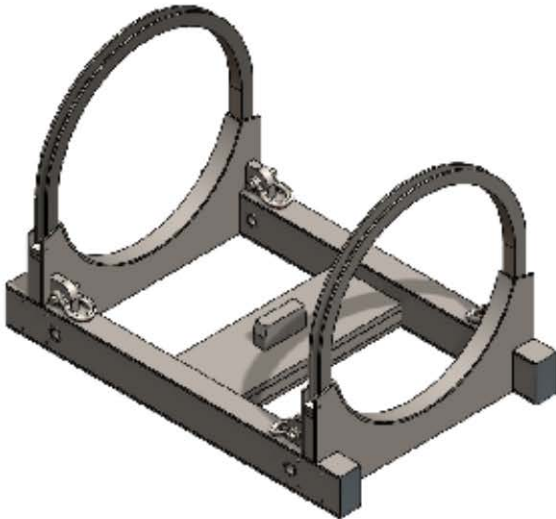
**FIGURE C-11A: FAMILY 3 CRADLE FOR MP197 CASK**



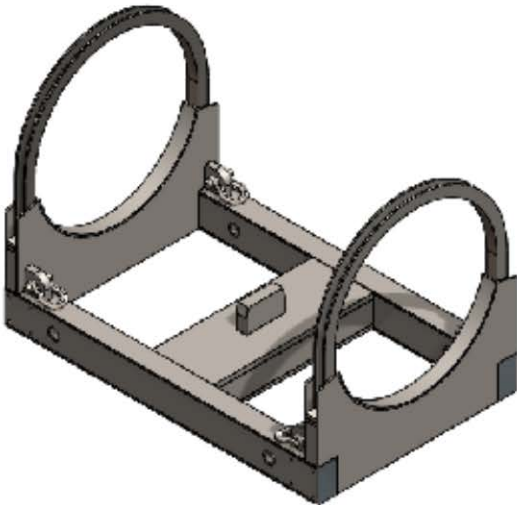
**FIGURE C-11B: FAMILY 3 CRADLE WITH MP197 CASK**



**FIGURE C-12: FAMILY 3 CRADLE FOR MP197HB CASK**

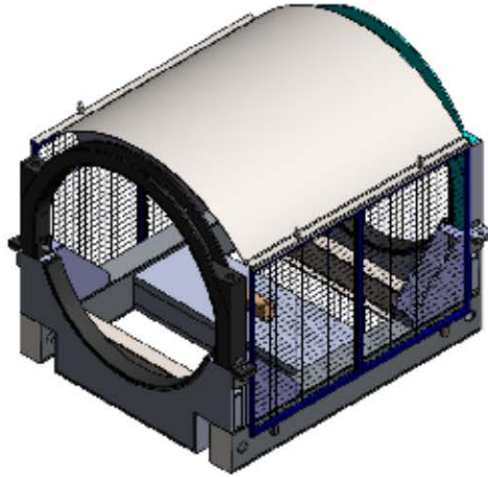


**FIGURE C-13: FAMILY 3 CRADLE FOR TS125 CASK**

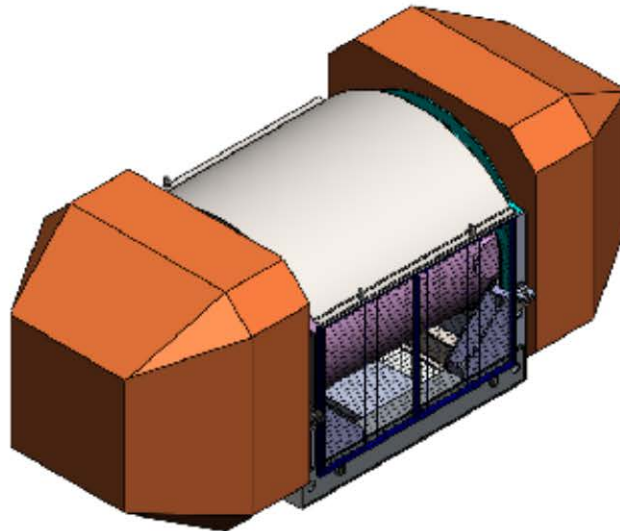




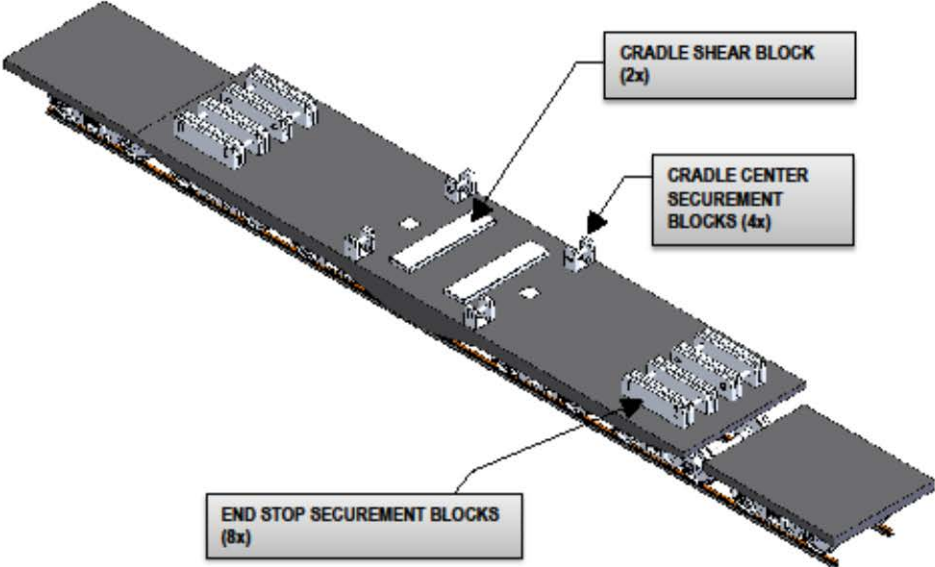
**FIGURE C-14A: FAMILY 4 CRADLE FOR MP187 CASK**



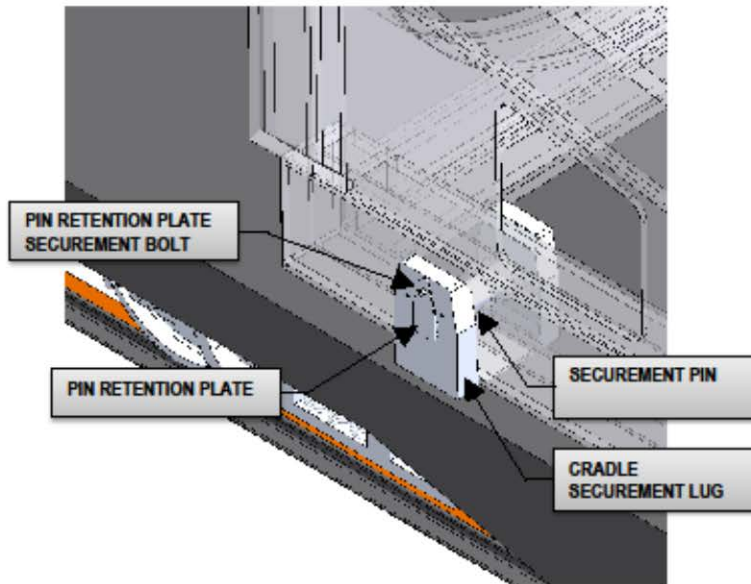
**FIGURE C-14B: FAMILY 4 CRADLE WITH MP187 CASK**



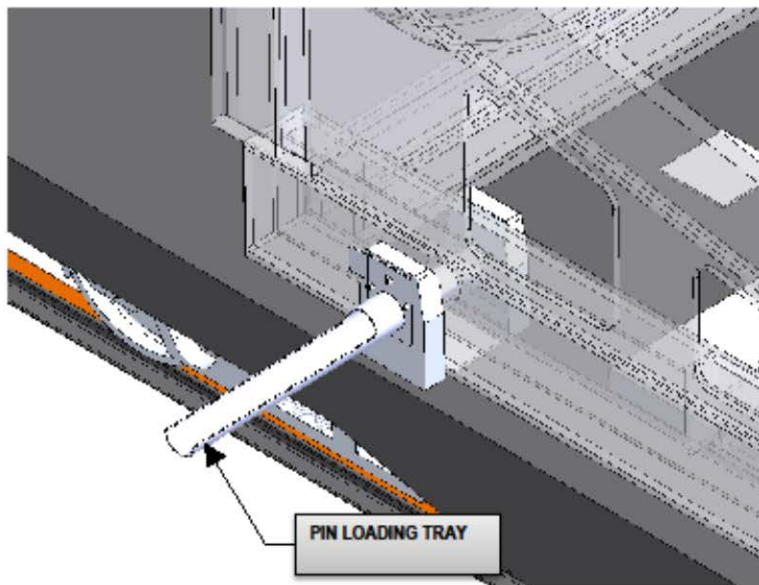
**FIGURE C-15: CRADLE ATTACHMENT DETAILS**



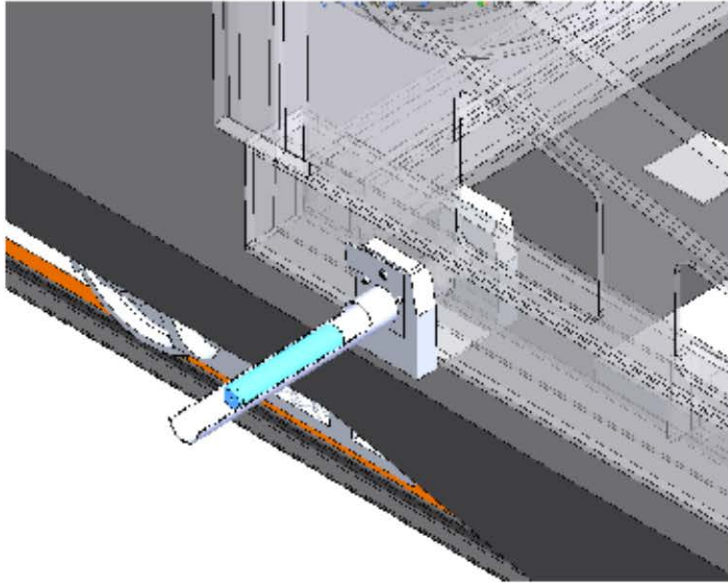
**FIGURE C-16: SECUREMENT PIN RETENTION FEATURES**



**FIGURE C-17: PIN LOADING TRAY INSTALLED**



**FIGURE C-18: PIN LOADING TRAY WITH PIN RETRACTED**





**FIGURE C-19: ATLAS RAILCAR BALLAST WEIGHTS**

