

2017 PROJECT PEER REVIEW

U.S. DEPARTMENT OF ENERGY
BIOENERGY TECHNOLOGIES OFFICE



This page is intentionally left blank

INTRODUCTORY LETTER



Dear colleagues,

In the spring and summer of 2017, the Office of Energy Efficiency and Renewable Energy's (EERE's) Bioenergy Technologies Office (BETO or the Office) continued its longstanding commitment to transparency by implementing the seventh biennial external review of its research and development portfolio. The review was conducted in accordance with EERE Peer Review guidelines, and it was designed to provide an external assessment of the projects in BETO's portfolio and collect external stakeholder recommendations on the Office's overall scope, focus, and strategic direction. Results from the Peer Review process are used to inform programmatic decision making; enhance active project management; and modify, expand, or discontinue existing projects.

The Peer Review process is critical in evaluating past investments and demonstrating the success of BETO's new core mission: to invest in the research and development of technologies that will reduce technology uncertainty and enable industry to stand up an advanced and sustainable bioenergy sector. Our nation's abundant biomass and waste resources present a tremendous opportunity to sustainably produce high-performance, advanced biobased fuels, products, and renewable chemicals and help realize national goals for the future bioeconomy. The Peer Review process enables external stakeholders to provide feedback on the most impactful use of taxpayer funding and develop recommendations for the most efficient and effective ways to accelerate the development of an advanced bioeconomy.

The 2017 Peer Review comprised three levels of review: (1) individual projects were scored based on technical approach, relevance, progress, and future direction; (2) each technology area portfolio was evaluated for overall potential impact, innovation, synergies, focus, commercialization, and recommendations; and (3) the Office's structure and overall strategic direction was reviewed by an external Steering Committee. This report contains the results of each level of review and the inputs of more than 300 participants in the Peer Review process, including principal investigators, reviewers, Steering Committee members, and BETO staff. The Office would like to thank all of the reviewers and members of the Steering Committee who participated in this review. BETO would like to offer a special thanks for BCS, Incorporated's support in aiding the planning and implementation of this review process.

BETO is appreciative of the valuable insights and contributions that have been provided throughout the Peer Review process. Achieving the objectives of the Office is dependent on the effective management of all the projects in BETO's existing portfolio and on the appropriate focus and structure of future initiatives. BETO values the input of all the stakeholders in the bioenergy sector and looks forward to working with them in the years ahead to continue progress on the path toward building a successful advanced bioenergy industry and a sustainable bioeconomy.

Sincerely,

A handwritten signature in black ink, appearing to read "Jonathan Male".

Dr. Jonathan Male

Director, Bioenergy Technologies Office
Office of Energy Efficiency and Renewable Energy
U.S. Department of Energy

EXECUTIVE SUMMARY

The Bioenergy Technologies Office (BETO) manages a diverse portfolio of projects across the spectrum of applied research and development within the dynamic context of developing technologies and evolving market conditions, as well as changing budgets and administration priorities. BETO's portfolio is organized according to the biomass-to-bioenergy supply chain—from feedstock source to end use—as illustrated in Figure ES-1.

The biennial Peer Review process enables external stakeholders to provide feedback on the responsible use of taxpayer funding and develop recommendations for the most efficient and effective ways to accelerate the development of an advanced bioenergy industry. BETO worked with the external Peer Review Steering Committee and Technology Area Review Panels to conduct the review process from July 2016 through July 2017. This report includes the results of both the Project Peer Review meeting held in March 2017 and the Program Management Review meeting held in July 2017.



Figure ES-1. Biomass-to-Bioenergy Supply Chain

ACRONYMS AND ABBREVIATIONS

3HP	3-hydroxypropionate
A&S	Analysis and Sustainability
ABC	Algal Biomass Conversion
ABPDU	Advanced Biofuels Process Demonstration Unit
ABY	Algal Biomass Yield
ACN	acrylonitrile
ACSC	Advanced Catalyst Synthesis and Characterization
AD	anaerobic digestion
ADO	Advanced Development and Optimization
Agile BioFoundry	Agile Biomanufacturing Foundry
AMO	Advanced Manufacturing Office
ANL	Argonne National Laboratory
AOP	annual operating plan
ARPA-E	Advanced Research Projects Agency – Energy
ASSERT	Analysis of Sustainability, Scale Economics, Risk, and Trade
ASTM	American Society for Testing and Materials
ASU	Arizona State University
ATEC	Algae Technology Educational Consortium
ATJ	alcohol-to-jet
ATP3	Algae Testbed Public–Private Partnership
AVAP	American Value-Added Pulping
BAT	Biomass Assessment Tool
BAU	business as usual
BDO	butanediol
BETO	Bioenergy Technologies Office
BFNUF	Biomass Feedstock National User Facility
BIC	Biofuels Information Center
BCT	Biomass Conversion Technology
BMP	best management practices
BSM	Biomass Scenario Model
BT16	2016 Billion-Ton Report
BTEX	benzene, toluene, ethylbenzene, xylenes
C	carbon
C5	five-carbon
C6	six-carbon
CA	carbonic anhydrase
CAP	Combined Algal Processing
CAPS	Coordinated Agriculture Projects
CARB	California Air Resources Board

CBP	consolidated bioprocessing
CCM	Catalyst Cost Model
CCPC	Consortium for Computational Physics and Chemistry
CEMAC	Clean Energy Manufacturing Analysis Center
CFP	catalytic fast pyrolysis
CH₄	methane
ChemCatBio	Chemical Catalysis for Bioenergy
CO	carbon monoxide
CO₂	carbon dioxide
Co-Optima	Co-Optimization of Fuels and Engines
CRADA	cooperative research and development agreement
DDA	deacetylation/dilute acid
DISCOVR	Development of Integrated Screening, Cultivar Optimization, and Validation Research
DMR	deacetylation/mechanical refining
DMT	Demonstration and Market Transformation
DOE	U.S. Department of Energy
DOI	U.S. Department of the Interior
DPA	Defense Production Act
EERE	Office of Energy Efficiency and Renewable Energy
EMDS	Ecosystem Management Decision Support
EPA	U.S. Environmental Protection Agency
FAPRI	Food and Agricultural Policy Research Institute
FASOM	Forest and Agricultural Sector Optimization Model
FCC	fluid catalytic cracking
FCIC	Feedstock-Conversion Interface Consortium
FOA	funding opportunity announcement
FPEAM	Feedstock Production Emissions to Air Model
FSL	Feedstock Supply and Logistics
FSMA	Food Safety Modernization Act
F-T	Fischer-Tropsch Process
FY	fiscal year
GAI	Global Algae Innovations Inc.
GCAM	Global Change Assessment Model
gge	gasoline gallon equivalent
GHG	greenhouse gas
GMO	genetically modified organism
GREET	Greenhouse Gases, Regulated Emissions, and Energy Use in Transportation
GTAP	Global Trade Analysis Project
HTL	hydrothermal liquefaction
IBE	isopropanol, butanol, and ethanol
IBR	integrated biorefinery

IEA	International Energy Agency
IH2	Integrated Hydrolysis Plus Hydroconversion Technology
INL	Idaho National Laboratory
IP	intellectual property
IPCC	Intergovernmental Panel on Climate Change
JEDI	Jobs and Economic Development Impact (Model)
KDF	Knowledge Discovery Framework
kg	kilogram
L	liter
LAP	laboratory analytical procedures
LCA	life-cycle analysis
LEAF	Landscape Environmental Assessment Framework
LEAPS	Laboratory Environmental Algae Pond Simulator
LLNL	Lawrence Livermore National Laboratory
LUC	land-use change
MC	membrane carbonation
MFSP	minimum fuel selling price
MOOC	Massive Open Online Courses
MSS	Moisture Swing Sorption
MSW	municipal solid waste
MT	Market Transformation
MYPP	Multi-Year Program Plan
NA	nanostuctured adsorbents
NGO	nongovernmental organization
NIFA	National Institute of Food and Agriculture
NIR	near infrared
NREL	National Renewable Energy Laboratory
ORNL	Oak Ridge National Laboratory
OTA	octatrienoic acid
PACE	Producing Algae and Co-Products for Energy
PAT	process analytical technologies
PBR	photobioreactor
PDU	Process Demonstration Unit
PD2B3	Project Definition for Pilot- and Demonstration-Scale Manufacturing of Biofuels, Bioproducts, and Biopower
PHA	polyhydroxyalkanoate
PHB	polyhydroxybutyrate
PI	principal investigator
PNNL	Pacific Northwest National Laboratory
RAFT	Regional Algal Feedstock Testbed Partnership
R&D	research and development

REACH	Renewable Acid-Hydrolysis Condensation Hydrotreating
RFS	Renewable Fuel Standard
RINS or RIN	Renewable Identification Number
RSB	Roundtable on Sustainable Biomaterials
SCADA	supervisory control and data acquisition
SCOPE	Scientific Committee on Problems of the Environment
SD	System Dynamics
SDSU	South Dakota State University
SNL	Sandia National Laboratories
SOC	soil organic compound
SOFC	solid-oxide fuel cell
SOT	state of technology
SRWC	short-rotation woody crops
STEM	science, technology, engineering, and math
SUNY	State University of New York
2016 Strategic Plan	Strategic Plan for a Thriving and Sustainable Bioeconomy
SWAT	Soil and Water Assessment Tool
TCPDU	Thermochemical Process Development Unit
TEA	techno-economic analysis
THF	tetrahydrofuran
TRL	technology readiness level
TRY	titer, rate, and yield
USDA	U.S. Department of Agriculture
USFS	U.S. Forest Service
USFS FIA	U.S. Forest Service Forest Inventory and Analysis
VGO	vacuum gas oil
VTO	Vehicle Technologies Office
w/w	weight by weight
WBS	work breakdown structure
WTE	Waste to Energy
wt%	weight percent
WWTP	wastewater treatment plant

TABLE OF CONTENTS

INTRODUCTORY LETTER	i
EXECUTIVE SUMMARY	ii
ACRONYMS AND ABBREVIATIONS.....	iii
INTRODUCTION	1
FEEDSTOCK SUPPLY AND LOGISTICS	12
FEEDSTOCK-CONVERSION INTERFACE CONSORTIUM.....	76
ADVANCED ALGAL SYSTEMS	112
CONVERSION R&D	222
<i>THERMOCHEMICAL CONVERSION R&D</i>	226
<i>BIOCHEMICAL CONVERSION R&D</i>	328
<i>WASTE TO ENERGY</i>	462
DEMONSTRATION AND MARKET TRANSFORMATION	500
<i>CO-OPTIMIZATION OF FUELS AND ENGINES</i>	524
ANALYSIS AND SUSTAINABILITY	550
STRATEGIC COMMUNICATIONS	658
PROGRAMMATIC EVALUATION AND RESPONSE.....	672

INTRODUCTION

The U.S. Department of Energy's (DOE's) Bioenergy Technologies Office (BETO or the Office) framed its 2017 Peer Review process in the context of two guiding documents that were released the prior year. The *Strategic Plan for a Thriving and Sustainable Bioeconomy* (2016 Strategic Plan) and BETO's 2016 *Multi-Year Program Plan* (MYPP) are referenced throughout this report. Both plans are summarized in the following section to introduce the vision, mission, goals, and structure of the Office. The 2016 Strategic Plan and 2016 MYPP overviews are followed by an overview of the Peer Review process and the format of this report. Since this project portfolio was reviewed, BETO has made a strategic shift to early-stage research and development (R&D) to build the knowledge base upon which industry can develop and deploy technologies that enable continued growth of the U.S. bioeconomy.

2016 Strategic Plan Overview

In 2016, BETO published a strategic plan that reflects the transformation and the advancements made in the bioenergy industry since the 1990s. The 2016 Strategic Plan expands BETO's mission beyond the cellulosic ethanol market to include renewable drop-in fuels (including diesel and jet fuels), biobased chemicals, and bioproducts. The new strategy also emphasizes the need to address environmental concerns associated with increased agricultural demand, including water and soil quality. The 2016 Strategic Plan is intended as an operational guide for managing and coordinating activities among technology areas. The plan is BETO's blueprint for tackling the challenges and opportunities associated with building a sustainable U.S. bioeconomy. While the BETO vision is set for 2040, it is important that processes are in place to verify progress, understand competing technologies, and revisit specific strategies every 5 years.

The 2016 Strategic Plan aligns with the Office of Energy Efficiency and Renewable Energy's *2016–2020 Strategic Plan and Implementing Framework* vision, mission, and relevant strategic goals. The main components of BETO's 2016 Strategic Plan include key opportunity areas, a strategic goal for each key opportunity area, and strategies for accomplishing each strategic goal. These components are intended to be crosscutting programmatic-level guidance and should be used to determine how to adapt and align BETO activities and project portfolios to best meet BETO's objectives and carry out the Office's mission in a continually changing environment.

BETO's 2016 Strategic Plan, which encompasses programmatic-level guidance, set the foundation for the projects reviewed in this portfolio. The 2016 MYPP identified research, development, and demonstration pathways and performance goals and outlined how BETO could meet its mission and vision. The projects in the portfolio reviewed during the 2017 Project Peer Review were established either through annual operating plans (AOPs) or through competitive funding opportunity announcements (FOAs). National laboratory recipients prepare AOPs for BETO review annually prior to each fiscal year (FY), and BETO develops FOAs based upon stakeholder input about R&D gaps and resources needed. Both AOPs and FOAs include project management plans that outline the implementation approach for the project to achieve strategic and performance goals.

BETO conducts R&D activities through an integrated supply chain approach addressing supply (feedstocks), conversion, distribution, and end use. Several activities underscore BETO's R&D—sustainability, strategic analysis, and communications—which enable development and dissemination of knowledge and tools related to the economic, environmental, and social dimensions of advanced bioenergy. While cellulosic biofuel production is BETO's primary focus, BETO also supports the production of chemical intermediates that are traditionally petroleum-de-

rived but can be produced from biomass. These intermediates are converted into high-value bioproducts, including bioplastics, biobased chemicals, lubricants, solvents, cosmetics, and food ingredients, such as algae oil—all of which have places in today’s commercial markets.

During Fiscal Year 2017, BETO made a strategic shift to early-stage R&D that resulted in renaming the Demonstration and Market Transformation (DMT) Technology Area to Advanced Development and Optimization (ADO). This name change reflects a reframing of the program area’s focus away from demonstration-scale projects into a lower technology readiness level (TRL) space. While BETO plans to operate within a lower TRL scale (TRL 4–6) to better leverage investments under a constrained budget, it also plans to prioritize the utilization of existing resources and to build upon past investments in order to help the industry progress.

The new role of the ADO Program has not yet been fully established, and, as such, the Office is planning to solicit stakeholder input. BETO will hold a public meeting to define the value the new ADO Program can provide stakeholders working to develop the bioenergy industry. The public meeting will also raise awareness of existing assets from past investments and identify future needs and opportunities. Through this public meeting, BETO aims to both provide clarity on BETO’s new operating constraints and mission space and to engage with stakeholders to better understand public needs and priorities within this mission space.

Figure 1 summarizes the 2016 Strategic Plan, which guided BETO’s implementation of the project portfolio reviewed in 2017. Key opportunities reflect the best paths available to support BETO’s mission, and each opportunity is aligned with a strategic goal, which will be achieved by implementing a range of strategies.

DOE Mission

Enhance U.S. security and economic growth through transformative science, technology innovation and market solutions to meet our energy, nuclear security and environmental challenges.

EERE Vision

A strong and prosperous America powered by clean, affordable, and secure energy.

Relevant EERE Strategic Goals

- Accelerate the development and adoption of sustainable transportation technologies.
- Stimulate the growth of a thriving domestic clean energy manufacturing industry.
- Lead efforts to improve federal sustainability and implementation of clean energy solutions.

BETO Vision 2040

A thriving and sustainable bioeconomy fueled by innovative technologies.

BETO Mission

Developing and demonstrating transformative and revolutionary sustainable bioenergy technologies for a prosperous nation.

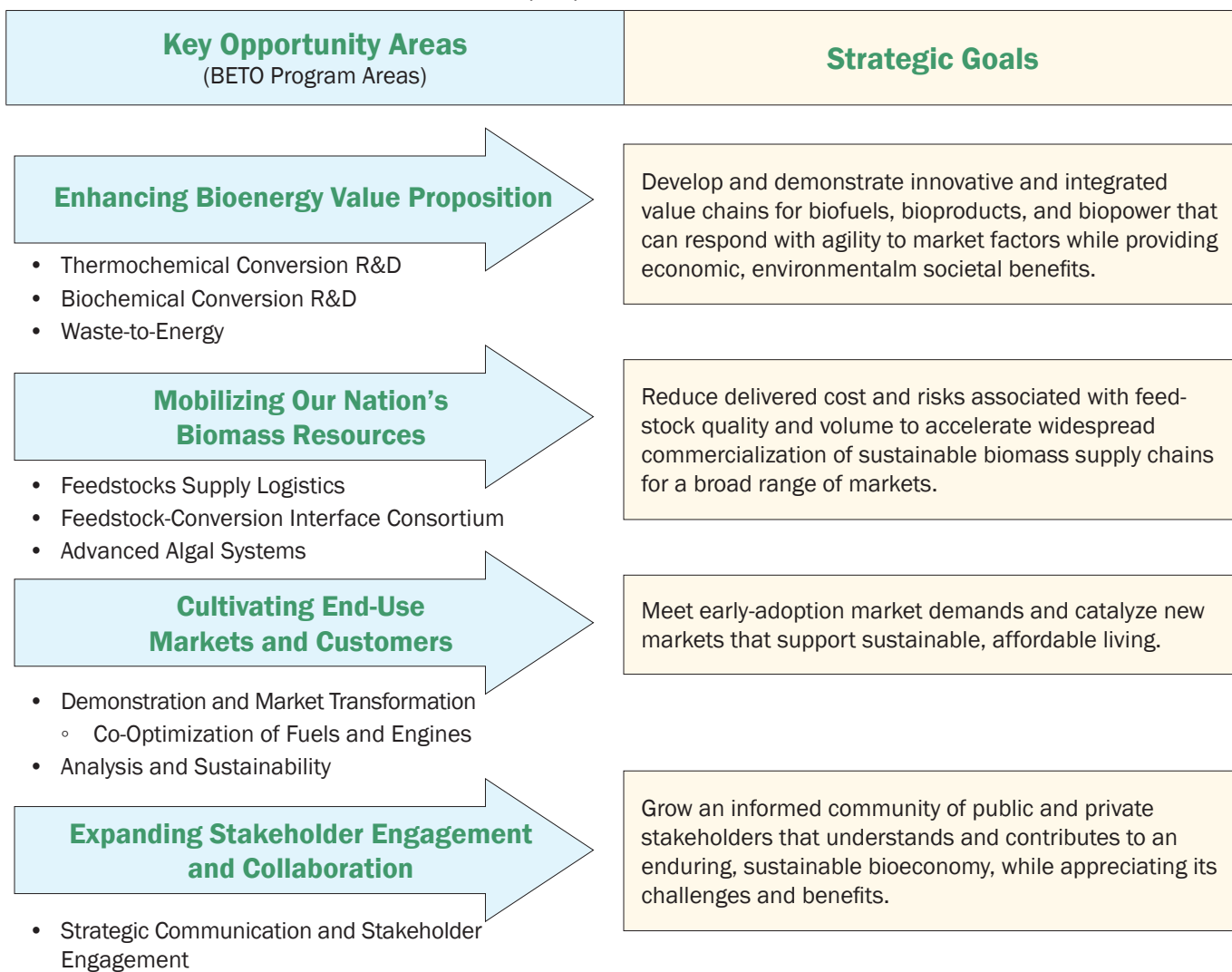

Figure 1. BETO 2016 Strategic Plan summary and program areas crosswalk

MYPP Overview

The MYPP, released in March 2016, sets forth BETO’s goals and structure; identifies the R&D, market transformation, and crosscutting goals and activities that BETO will focus on over the next 5 years; and describes how these activities are critical in meeting the nation’s future economic and energy challenges. The MYPP is intended for use as an operational guide to help BETO manage and coordinate its activities, as well as a resource to communicate its mission, goals, plans, and priorities to stakeholders and the public.

BETO manages a diverse portfolio of technologies across the spectrum of applied R&D within the dynamic context of developing technologies and evolving market conditions. BETO’s portfolio is organized according to the biomass-to-bioenergy supply chain—from the feedstock source to end use. The MYPP identifies technical and market challenges and barriers to be addressed for each program area, as well as those that cross the entire supply chain.

Figure 2 shows how BETO’s program areas align with supply-chain elements, with major emphases on feedstock supply and biomass conversion and how crosscutting programs support all areas. Key components of the portfolio include the following:

- Conducting R&D on robust feedstock supply systems to deliver large quantities of quality feedstocks
- Conducting R&D on high-productivity advanced algal systems
- Conducting R&D on conversion technologies able to process diverse and variable feedstocks
- Developing and verifying biorefinery technologies at minimal, scalable, engineering scale
- Addressing distribution, end-use, and market challenges and opportunities
- Performing crosscutting sustainability, strategic analysis, and strategic communications activities.

Research, Development, Demonstration, and Market Transformation			
Feedstock Supply and Logistics	Advanced Algal Systems	Conversion	Demonstration and Market Transformation
Develop high-volume distribution network of sustainable, quality biomass feedstocks.	Increase algal productivity, while maximizing the yield of products and chemicals.	Optimize conversion efficiency while improving quality of intermediates, fuels and products.	Demonstrate performance at increasing scales to enable commercial biorefineries.
Crosscutting			
Sustainability	Strategic Analysis	Strategic Communications	
Quantify effects and enhance the benefits of advanced bioenergy with regard to water, air, soil, and quality of life.	Internal and external strategic program analyses and development of tools to understand the impacts of the bioeconomy.	Disseminate research and development impacts while educating the public on environmental and economic benefits of technological advances.	

Figure 2. BETO program area alignment with the biomass-to-bioenergy supply chain¹

¹ Feedstocks Supply and Logistics includes the Feedstock-Conversion Interface Consortium. Conversion R&D includes Thermochemical Conversion R&D, Biochemical Conversion R&D, and Waste to Energy. Demonstration and Market Transformation (DMT) includes the Co-Optimization of Fuels and Engines. In FY 2017, outside the scope of this review, BETO redefined activities within the DMT portfolio to align with administrative priorities and renamed this program area Advanced Development and Optimization.

BETO 2017 Peer Review Overview

The Project Peer Review meeting took place on March 6–9, 2017, in Denver, Colorado. During the public event, project investigators (PIs) presented 182 presentations covering 277 projects in BETO’s R&D portfolio. These projects were systematically reviewed by more than 40 external subject matter experts from industry, academia, and federal agencies. The Project Peer Review included simultaneous review sessions of projects within nine technology areas; some of these technology areas are primary program areas, while some are sub-categories of the primary program areas, as indicated below:

- Feedstock Supply and Logistics (FSL)
 - Feedstock-Conversion Interface Consortium (FCIC)
- Advanced Algal Systems (Algae)
- Conversion R&D
 - Thermochemical Conversion R&D (Thermochem)
 - Biochemical Conversion R&D (Biochem)
 - Waste to Energy (WTE)
- Analysis and Sustainability (A&S)
- Demonstration and Market Transformation (DMT)/ADO
 - Co-Optimization of Fuels and Engines (Co-Optima).

The Program Management Review meeting took place on July 13, 2017, in Arlington, Virginia, and provided an Office-level assessment of strategic planning and programmatic initiatives.

The projects reviewed represent a total DOE investment of more than \$700 million, approximately \$300 million of which was allocated during the period covered by this Peer Review (FY 2015–2017). Each Review Panel developed overall recommendations regarding the focus, management, and impact of the projects in each technology area. In addition, an external Steering Committee reviewed the Strategic Communications portfolio and the Review Panel summary reports from each technology area to develop overall recommendations for the Office. Results of the 2017 Peer Review have been, and will be, used to help inform programmatic decision making, modify or discontinue existing projects, guide future funding opportunities, and support other budget and strategic planning objectives.

The Peer Review brought together reviewers and BETO staff with PIs and other stakeholders along the entire bio-energy supply chain. Converging stakeholders in this way creates synergy across technology areas and enables the cross-fertilization of ideas and expertise, while providing for a more comprehensive review process. Figures 3 and 4 depict the BETO total project portfolio reviewed by technology area session and funding allocation.

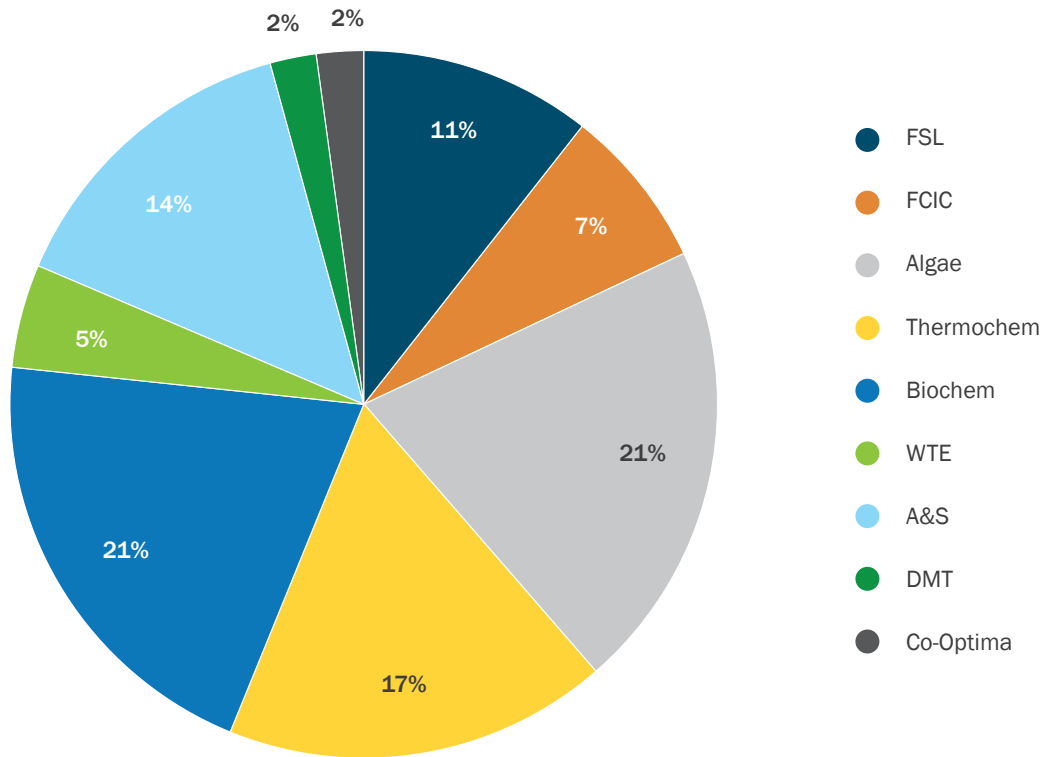

Figure 3. BETO project portfolio—number of projects by technology area session

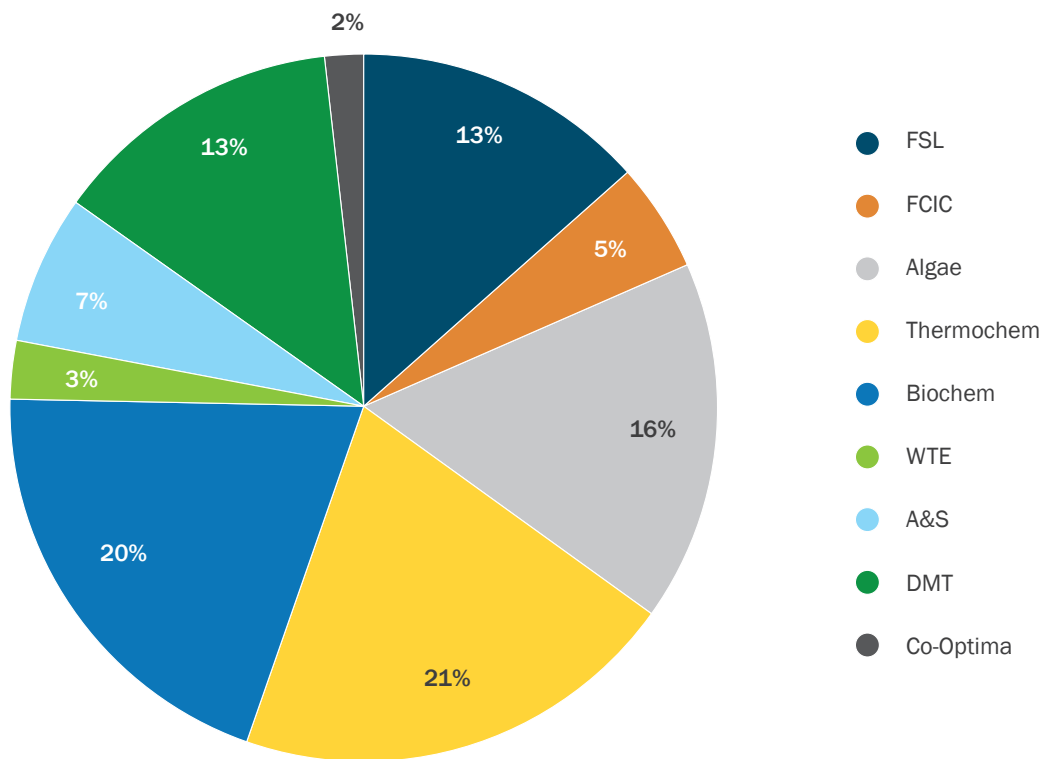

Figure 4. BETO project portfolio—total budget by technology area session. Note: Due to rounding, whole numbers in this chart do not add up to exactly 100%.

Roles and Responsibilities

The BETO 2017 Peer Review was conducted by an internal planning committee, an external Steering Committee, and nine external Review Panels. Upon initiation of the review process, an internal BETO planning committee was designated with the responsibility for coordinating all aspects of the review process, from initiation through completion. This committee included a lead and support person for each of the nine technology areas, as well as a chair, Valerie Reed, a deputy chair, Nichole Fitzgerald, and overall coordination support. Support contractors from BCS, Incorporated provided planning support for each session, developed an online reviewer evaluation system, facilitated development of report materials, and compiled and drafted the final Peer Review Report.

At the beginning of the process, the BETO planning committee identified and recruited an external Steering Committee to represent the perspectives of academia, industry, the financial community, and non-governmental organizations. The Steering Committee provided independent and impartial guidance on planning activities and the selection of external reviewers; participated in the review process; and developed crosscutting recommendations on the Office's overall focus, scope, and strategic direction.

Review Panels for each technology area consisted of four to six external experts who were selected based on their technical expertise and high-level qualifications in their designated technology area. The BETO technology area teams proposed individual candidates, which were submitted to the external Steering Committee for input. Efforts were made to ensure a balance within each Technology Area Review Panel by including a mix of reviewers from industry, academia, and federal agencies, with a range of expertise in the many sub-focus areas within each technology area. Review Panel members were required to sign legal agreements stipulating an absence of a conflict of interest with the projects they reviewed. The internal planning committee and BETO's director made the final decisions on reviewer selection. Each Review Panel was guided by a Lead Reviewer who, in most cases, had previous experience participating in a BETO Peer Review.

Table 1 and Table 2 list the members and affiliations of the Peer Review Steering Committee and the Lead Reviewers, respectively. Members of each Technology Area Review Panel are listed within each of the technology area session summaries.

Table 1. Steering Committee Members

Name	Affiliation
Mike Lakeman*	Boeing
Steven Costa	U.S. Department of Transportation
John May	Stern Brothers & Co.
Shelie Miller	University of Michigan
Dawn Mullally	American Lung Association
Robert (Bob) Rummer	University of Kansas
Bob Wooley	Biomass ad <i>infinitem</i> LLC

*Lead Reviewer

Table 2. Lead Reviewers

Name	Technology Area Review Panel	Affiliation
Steve Searcy	FSL	Texas A&M University
Gerson Santos Leon	FCIC	Abegnoa
Eric Jarvis	Algae	Independent Consultant
Candace Wheeler	A&S	General Motors (Retired)
Suzanne Lantz	Biochem	DuPont
Shawn Freitas	Thermochem	ThermoChem Recovery International
F. Michael McCurdy	DMT/ADO	Leidos
Luca Zullo	WTE	VerdeNero LLC

Project Categories and Evaluation Criteria

Each project in the BETO portfolio was categorized based upon its start and/or end date. To capture projects that have been active since the 2015 Peer Review, the three project categories are as follows:

- Sun-setting (projects with end dates between October 2015 and October 2017)
- Ongoing (projects with end dates after October 2017 and start dates prior to October 2016)
- New (projects with start dates after October 2016).

Project scoring involved weighting the evaluation criteria based upon each project’s category. The weighting for project categories and evaluation criteria is illustrated in Table 3.

Table 3. Project Evaluation Criteria Weighting

Review Criteria Weights	Project Categories		
	Sun-Setting Projects <i>(end date between October 2015 and October 2017)</i>	Ongoing Projects	New Projects <i>(start date after October 2016)</i>
Approach	25%	25%	25%
Accomplishments/ Progress	50%	25%	0%
Relevance	25%	25%	25%
Future Work	0%	25%	50%

Review Panel members were asked to evaluate each project on specific criteria: approach, accomplishments/progress, relevance, and future work. These evaluation criteria, as described below, served as the standard template for the scores and comments provided to each project.

- **Approach**—Projects were evaluated on the degree to which they developed a thorough approach involving the following components:
 - The project performers have implemented technically sound research, development, and deployment approaches and have demonstrated the results needed to meet their targets.
 - The project performers have identified a project management plan that includes well-defined milestones and adequate methods for addressing potential risks.
 - The project performers have clearly described critical success factors that will define technical and commercial viability, and they have explained and understand the challenges they must overcome to achieve success.
- **Accomplishments/Progress**—Projects were evaluated on the degree to which they demonstrated accomplishments during the project award period:
 - The project performers have made progress in reaching their objectives based on their project management plan. The project performers have described their most important accomplishments in achieving milestones, reaching technical targets, and overcoming technical barriers.
 - The project performers have clearly described the progress since the period of the last review.
- **Relevance**—Projects were evaluated on the degree to which they contributed value to the broader BETO vision and industry development:
 - The project performers have described how the project contributes to meeting program/technology area goals and BETO objectives, as cited in the MYPP.
 - The project performers have considered applications of their expected outputs.
 - The project performers have presented the relevancy of the project and how successful completion of the project will advance the state of technology and impact the viability of commercial bioenergy applications.
- **Future Work**—Projects were evaluated on the degree to which they are positioned for further accomplishments:
 - The project performers have outlined adequate plans for future work, including key milestones and go/no-go decision points.
 - The project performers have communicated key planned milestones and addressed how they plan to deal with upcoming decision points and any remaining issues.

Format of the Report

Information in this report has been compiled based on the following sources and is organized as follows:

- 1. Peer Review Report Introduction:** This section contains overview information on the Peer Review process, roles and responsibilities, and project evaluation criteria.
- 2. BETO Overview:** This section provides an overview of BETO’s mission, vision, and goals, as well as descriptions of the Office’s approach to achieving goals and the market barriers that create challenges to doing so.
- 3. Technology Area Summaries:** These nine sections represent the comprehensive evaluation for each of the nine technology areas reviewed. Each section includes the following components:
 - i. Introduction:* Overview of the technology area’s project portfolio, including total funding allocated for FY 2015–FY 2016 and percentage of total BETO project portfolio.
 - ii. Program Overview:* Background information about the BETO program that operates the given technology area, including program scope, R&D activities, important definitions. This component also includes context on the program’s approach for overcoming challenges and for supporting BETO strategic and performance goals.
 - iii. Review Panel Members:* A list of names and affiliations for each of the individuals who provided project evaluations and contributed to the Review Panel’s summary report.
 - iv. Technology Area Score Results:* This chart depicts the average weighted score for each project in each technology area.
 - v. Review Panel Summary Report:* A summary of project evaluations that provides insight into the technology area’s overall impact, level of innovation, leverage of synergies, appropriate focus, feasibility for commercialization, and top recommendations. The Lead Reviewer for each technology area drafted this summary in consultation with the full Technology Area Review Panel. Consensus among the reviewers was not required, and reviewers were asked to include differences of opinion and dissenting views within the report.
 - vi. Technology Area Programmatic Response:* The program’s official response to the recommendations provided in the Review Panel’s summary report.
 - vii. Project Evaluations:* The individual project reports, which constitute 2–3-page reports summarizing the results of each project evaluated during the review process. Each report includes the following elements:
 - a. Project Name and Work Breakdown Structure (WBS) Number:** The full project name is listed as the heading, with the identifying code underneath in parentheses. Project evaluations for each technology area are ordered by WBS number, from lowest to highest.
 - b. Weighted Project Score:** Each project’s average weighted score is stated numerically. A box and whisker chart depicts the average scores for each evaluation criterion, as well as the range of scores given to the project by the individuals within the Review Panel. The chart also indicates the average value for each evaluation criterion across all projects within the technology area.
 - c. Summary Table:** Each report provides reference information about the project, including the recipient organization, PI name, project dates, project type, and funding values.

- 1) Recipient: The recipient indicates the organization tasked with leading the project (this may include multiple organizations in situations where the project has more than one recipient).
 - 2) Principle Investigator: The PI is the individual affiliated with the recipient organization who is assigned to lead the project.
 - 3) Project Category: Each project is categorized as sun-setting, ongoing, or new, based on its start/end date.
 - 4) Project Type: There are many types of projects within the BETO portfolio, but this review focused primarily on two types of projects: (1) AOPs, which are core R&D projects performed by DOE's national laboratories, and (2) projects awarded through a funding opportunity announcement, which are indicated in this table by listing the FOA's name, number, and fiscal year.
 - 5) Funding: The funding is the allocated project budget. Values for AOPs are available on a fiscal year basis, while competitively awarded project funding is only available as a total value.
- d. Project Descriptions: Project descriptions are compiled from the abstracts that the PIs submitted for each project.
 - e. Overall Impressions: These are verbatim comments made by the Review Panel, edited only for grammar and clarity. Each bulleted response represents the opinion of one reviewer. Reviewers were not asked to develop consensus remarks and, in most cases, did not discuss their overall comments on each project with one another. In a limited number of cases, reviewer remarks deemed inappropriate or irrelevant were excluded from the final report.
 - f. PI Response to Reviewer Comments: This is the PI's response to the reviewers' comments. In some cases, PIs chose to respond bullet by bullet to each of the reviewers' comments and, in other cases, provided only a summary response.

4.Strategic Communications Portfolio Evaluation: The Steering Committee provided a review of BETO's Strategic Communications efforts, with a focus on identifying strengths and limitations. Sections of this chapter cover alignment of investments with results, coordination with the Office, messaging, and audiences.

5.Strategic Communications Programmatic Response: This is the BETO Strategic Communications lead's response to the Steering Committee's Strategic Communications portfolio evaluation.

6.Programmatic Evaluation: This is the external Steering Committee's overall summary feedback and final recommendations following the conclusion of the Program Management Review. This report was based on the Steering Committee's participation in each component of the Peer Review process, as well as closed-door, facilitated review sessions following the Project Peer Review and the Program Management Review meetings. Components of this report include identification of overall strengths and weaknesses, comments on the portfolio impact, assessment of the Office's 2016 Strategic Plan, and input regarding technologies and market trends that may affect BETO's ability to achieve its goals.

7.BETO Programmatic Response: This is BETO leadership's official, comprehensive response to the Steering Committee's feedback and recommendations in their programmatic evaluation.

FEEDSTOCK SUPPLY AND LOGISTICS



TECHNOLOGY AREA



CONTENTS

INTRODUCTION	14
FSL OVERVIEW	14
FSL REVIEW PANEL	17
TECHNOLOGY AREA SCORE RESULTS.....	18
FSL REVIEW PANEL SUMMARY REPORT.....	19
FSL PROGRAMMATIC RESPONSE	22
SUPPLY FORECASTS AND ANALYSIS	25
FEEDSTOCK SUPPLY CHAIN ANALYSIS	28
RENEWABLE ENHANCED FEEDSTOCKS FOR ADVANCED BIOFUELS AND BIOPRODUCTS (REFABB)	31
BIOMASS ENGINEERING.....	33
DEVELOPMENT OF A WET LOGISTICS SYSTEM FOR BULK CORN STOVER.....	36
SIZE REDUCTION, DRYING AND DENSIFICATION OF HIGH MOISTURE BIOMASS	39
RESOURCE MOBILIZATION.....	42
FEEDSTOCK SUPPLY MODELING.....	45
DESIGN AND DEMONSTRATION OF AN ADVANCED AGRICULTURAL FEEDSTOCK SUPPLY SYSTEM FOR LIGNOCELLULOSIC BIOENERGY PRODUCTION.....	47
DEMONSTRATION OF AN ADVANCED SUPPLY CHAIN FOR LOWER COST, HIGHER QUALITY BIOMASS FEEDSTOCK DELIVERY.....	50
NEXT GENERATION LOGISTICS SYSTEMS FOR DELIVERING OPTIMAL BIOMASS FEEDSTOCKS TO BIOREFINING INDUSTRIES IN THE SOUTHEASTERN U.S.....	53
IMPROVED ADVANCED LOGISTICS UTILIZING WOODY AND OTHER FEEDSTOCKS IN THE NORTHEAST AND PACIFIC NORTHWEST.....	56
BIOMASS FEEDSTOCK NATIONAL USER FACILITY	58
US-INDIA CONSORTIUM FOR DEVELOPMENT OF SUSTAINABLE ADVANCED LIGNOCELLULOSIC BIOFUELS SYSTEMS.....	61
WASTE TO WISDOM: UTILIZING FOREST RESIDUES FOR THE PRODUCTION OF BIOENERGY AND BIOBASED PRODUCTS	64
CLEAN ENERGY MANUFACTURINGANALYSIS CENTER (CEMAC)	67
SDSU, SUN GRANT INITIATIVE, REGIONAL BIOMASS FEEDSTOCK DEVELOPMENT PARTNERSHIP.....	70
RESEARCH, EXTENSION, AND EDUCATIONAL PROGRAMS ON BIOBASED ENERGY TECHNOLOGIES AND PRODUCTS.....	72

INTRODUCTION

Six external experts from industry and academia reviewed 20 projects (18 presentations) during the Feedstock Supply and Logistics (FSL) portion of the 2017 Bioenergy Technologies Office (BETO or the Office) Project Peer Review. This review addressed a total U.S. Department of Energy (DOE) investment of approximately \$99,822,002, or 14% of the BETO portfolio. During the Project Peer Review meeting, the principal investigator (PI) for each project was given 15–60 minutes to deliver a presentation and respond to questions from the Technology Area Review Panel. Allotted time was dependent on funding level and relative importance to achieving BETO goals.

The Review Panel evaluated and scored projects based on the outlined review criteria (approach, technical progress and accomplishments, relevance to BETO goals, and future plans). This section of the report contains the results of the project review, including full scoring information for each project, summary comments from each reviewer, and any public response provided by the PI. Overview information on FSL, full scoring results and analysis, the Review Panel's summary report, and BETO's programmatic response are also included in this section.

BETO designated Dr. Alison Goss Eng and Dr. Steven Thomas as the FSL Technology Area Review Leads. In this capacity, Dr. Goss Eng and Dr. Thomas were responsible for all aspects of review planning and implementation.

FSL OVERVIEW

As the raw material for biomass-to-biofuels, bioproducts, and biopower value chains, a sufficient and secure supply of affordable, high-quality feedstocks is critical to accomplishing Office goals and enabling a meaningful and sustainable biomass conversion industry. FSL research and development (R&D) relates directly to, and strongly influences, many, if not all, of the downstream elements of the Office's portfolio and its respective goals and objectives.

The scope of the FSL Program includes terrestrial, lignocellulosic feedstocks (i.e., agricultural residues, forest resources, and dedicated energy crops), and select municipal solid waste (MSW) resources. Algae is only included as a blending agent (the Advanced Algal Systems Program was reviewed separately). The FSL Program encompasses sustainable feedstock production, resource assessment, and feedstock logistics operations up to the throat of the conversion reactor. These activities are directed at the following activities:

- Reducing the delivered cost of feedstock
- Improving and preserving the quality of harvested feedstock
- Improving environmental performance of feedstock production and logistics operations
- Expanding the volume of affordable, high-quality feedstock materials accessible to the developing bioenergy industry.

In addition, sustainable feedstock production R&D activities are focused on enabling the availability of abundant, affordable, high-quality biomass materials in the feedstock supply chain. There are three primary activities associated with sustainable feedstock production:

- Conducting resource assessments
- Validating the yield potential and sustainability of a variety of potential feedstock crops
- Characterizing the physical and chemical properties of cellulosic feedstock materials.

Resource assessment involves estimating current and future domestic biomass resources by type and geographic distribution at different price points. It also includes understanding and helping to improve quality attributes (e.g., moisture, ash, and carbon content) associated with those resources as a function of geography and price and evaluating the environmental sustainability constraints associated with accessing those biomass resources over time.

Feedstock logistics refers to the supply chain operations that occur between feedstock production sites and the biomass conversion reactor inlet. Activities in this area are primarily focused on how to most efficiently, inexpensively, and sustainably harvest and deliver high-quality biomass from a variety of crops to biorefinery end users. These operations include feedstock harvest and collection, storage, handling, preprocessing, and transport to the biorefinery.

Biomass may be transported between field or forest and conversion facility by truck, train, or barge using existing transportation infrastructure. Optimization of container (or biomass package) volumes and dimensions designed for moving biomass feedstocks that simultaneously reach both weight and volume limits would increase efficiencies in the feedstock supply chain and therefore decrease delivered feedstock cost. Existing transportation infrastructure demonstrates these efficiencies for many commodity materials. Preprocessing raw biomass to feedstocks with infrastructure-compatible characteristics can leverage key components of the existing infrastructure.

FSL SUPPORT OF OFFICE STRATEGIC GOALS

FSL's strategic goal of is to develop technologies to enable a sustainable, secure, reliable, and affordable supply of acceptable-quality terrestrial feedstock for

the U.S. bioenergy industry in partnership with the U.S. Department of Agriculture (USDA) and other key stakeholders. This goal supports the long-term goal (beyond 2040) to develop technologies and methods that could sustainably supply more than 1 billion dry tons of biomass per year.

The FSL Program directly addresses and supports resource assessment, sustainable crop production, biomass characterization, harvest, collection, storage, preprocessing, and delivery of feedstock for all potential biomass conversion pathways.

FSL SUPPORT OF OFFICE PERFORMANCE GOALS

The FSL Program is also taking the lead on five BETO success indicators/milestones, as published in BETO's *Strategic Plan for a Thriving and Sustainable Bioeconomy*² and BETO's 2016 *Multi-Year Program Plan* (MYPP)³:

- By 2018, establish nationwide sub-county-level environmental impact criteria and logistics strategies for all potential energy crops, including agricultural and forestry residues, annual and perennial herbaceous energy crops, and short-rotation woody energy crops
- By 2019, develop and provide a framework for multiple distributed processing scenarios for utilization of high-impact biomass feedstocks leading to commoditization, standardization, and risk mitigation
- By 2020, establish a vibrant and effective stakeholder engagement initiative coordinated within and between DOE, USDA, the U.S. Environmental Protection Agency, and other federal agencies to enable joint initiatives to advance and expand the U.S. bioeconomy

¹ U.S. Department of Energy, Bioenergy Technologies Office (BETO), *Strategic Plan for a Thriving and Sustainable Bioeconomy* (BETO, December 2016), https://www.energy.gov/sites/prod/files/2016/12/f34/beto_strategic_plan_december_2016_0.pdf.

² U.S. Department of Energy, Bioenergy Technologies Office (BETO), *Multi-Year Program Plan* (BETO, March 2016), https://www.energy.gov/sites/prod/files/2016/07/f33/mypp_march2016.pdf.

- By 2021, develop and verify cellulosic FSL systems that economically and sustainably supply 258 million dry tons per year (excluding biopower) at a delivered cost of \$84/dry ton (\$2014) to support a biorefining industry utilizing diverse biomass sources
- By 2022, verify at pilot or demonstration scale cellulosic FSL systems that can economically and sustainably supply 285 million dry tons per year (excluding biopower) at a mature modeled delivered cost of \$84/dry ton (\$2014) to support a biorefining industry utilizing diverse biomass resources.

In addition, the FSL Program contributes substantially to the success indicators and milestones listed in the Feedstock-Conversion Interface Consortium (FCIC) chapter of this report and also supports the following success indicators and milestones led by other BETO program areas:

- By 2017, verify at pilot scale at least one technology pathway for hydrocarbon biofuel production, demonstrating a mature modeled price of \$3/gasoline gallon equivalent (gge) with a greenhouse gas (GHG) emission reduction of 50% or more
- By 2018, in collaboration with BETO's Strategic Communications team, sponsor stakeholder engagement activities that seek to identify and enable markets for producers and users of biomass
- By 2018, complete a robust market analysis that identifies specific future commodity fuel and bio-product markets of interest and the markets that will support technology development and scaling in the near and medium terms
- By 2018, develop a set of market indicators to track progress of the growing domestic energy and bio-product industrial sectors
- By 2019, publish a multi-dimensional analysis that identifies and quantifies specific economic, environmental, and social benefits of a transition to a robust bioeconomy

- By 2020, provide an analytical framework for bio-products research by publishing market and life-cycle analyses, roadmaps, and/or reports
- By 2020, complete construction and initial operations for at least three pilot- and/or demonstration-scale integrated biorefineries to enable the subsequent development of pioneer commercial plants for advanced biofuels and bioproducts
- By 2022, verify at pilot or demonstration scale two additional pathways for hydrocarbon biofuel production at a mature modeled price of \$3/gge with a GHG emissions reduction of 50% or more with the option of incorporating a bioproducts strategy
- By 2022, verify modeled techno-economic feasibility of nth-plant \$3/gge from wet waste streams.

FSL APPROACH FOR OVERCOMING CHALLENGES

The milestones identified above need to be prioritized and addressed as funding permits in order to achieve the FSL's R&D goal to develop sustainable technologies that provide a secure, reliable, and affordable feedstock supply for the U.S. bioenergy industry. However, the following approaches are considered most critical and will be emphasized within the program's efforts:

- Increase the volume of sustainable, acceptable quality, cost-effective feedstock available to biorefineries by developing advanced feedstock supply systems and strategies
- Incorporate sustainability and feedstock supply risk into the resource assessments
- Work with the Conversion R&D Program to understand the range of acceptable physical and chemical in-feed specifications for the various conversion technology pathways under investigation
- Develop high-capacity, high-efficiency, low-cost, commercial-scale FSL systems that deliver stable, dense, flowable (in some cases), and consistent-quality infrastructure-compatible feedstock.

In the past, FSL Program research focused on modifying conventional terrestrial feedstock logistical systems that were designed and manufactured for traditional agricultural and forestry industries. Conventional systems are possibly suitable for high biomass-yielding regions but

not for medium-to-low-yielding areas. Supplying feedstock to a growing bioenergy industry requires increasing the accessible volumes of lignocellulosic feedstock, while increasing the emphasis on quality, as well as reducing variability and risk throughout the value chain.

FSL REVIEW PANEL

Name	Affiliation
Steve Searcy*	Texas A&M University
Emily Heaton	Iowa State University
Giovanna Aita	Louisiana State University Agricultural Center
Katherine Delany Behrman	University of Texas at Austin
Sudhagar Mani	University of Georgia
Gerson Santos Leon	Abengoa

*Lead Reviewer

TECHNOLOGY AREA SCORE RESULTS

Average Weighted Scores by Project

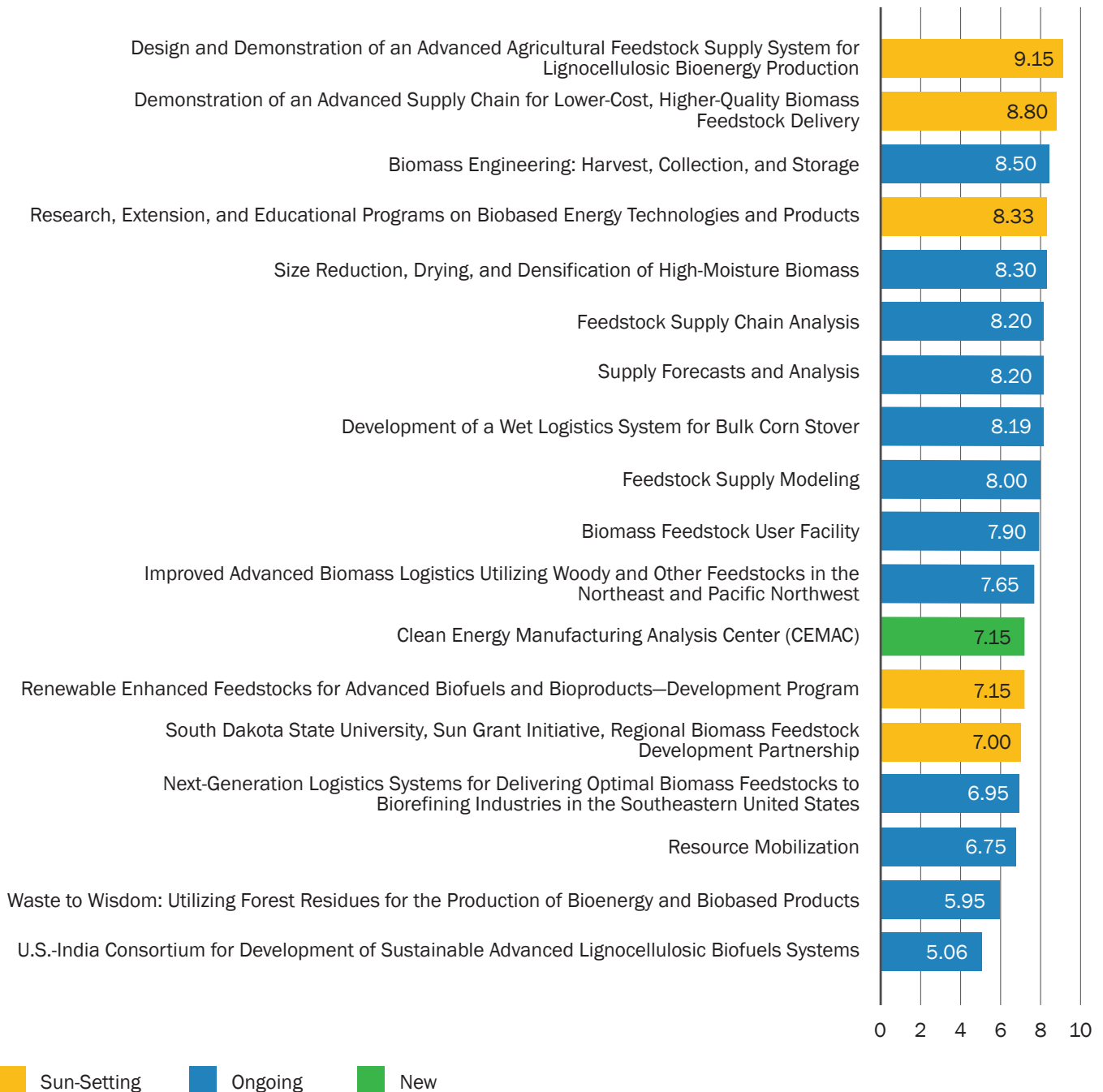

FSL REVIEW PANEL SUMMARY REPORT

Prepared by the FSL Review Panel

The suite of projects reviewed represented a full range of FSL topics, ranging from genetic manipulation of energy crops to national level analysis of feedstock supplies. As a group, they are intended to address the availability of biomass in sufficient quantity, quality, and cost to support the developing bioenergy industries. Review and analysis of the individual projects and the entire FSL Program was conducted in light of the observations and recommendations made in the fiscal year (FY) 2015 Peer Review.

Impact

BETO projects have a positive effect on the confidence in predicted feedstock availability and delivered cost estimates. Advancements in scientific understanding of regional energy crop/residue yields and the development of improved technologies for biomass collection, storage, and preprocessing have enhanced the development of business models necessary for commercial adoption. The diversity of funded projects has addressed most aspects of the systems needed to supply biorefineries. However, the portfolio includes some activities for which the Review Team had differing opinions regarding the value provided.

Projects viewed as having significant positive impact include the following:

- The Regional Feedstock Partnership coordinated by North Central Sun Grant Center has generated knowledge on biomass production of multiple crops across years and locations and provided the scientific underpinning for the *2016 Billion-Ton Report: Advancing Domestic Resources for a Thriving Bioeconomy (BT16)*.
- Supply forecasts and analysis for *BT16* built on the operational and economic data gathered on yields

and logistics systems to provide an increased level of sophistication in the prediction of the scope of a potential biofuels industry. The addition of sustainability estimates for biomass production systems addresses concerns by some industry critics and directly addresses recommendations of the 2015 Peer Review.

- Advanced logistics systems for crop residues, as well as herbaceous and woody crops, provide improved collection and delivery systems that support the nascent biofuels industry and create new machines and processes.
- Idaho National Laboratory's (INL's) projects to handle and store higher moisture biomass while maintaining quality and quantity have the potential for high impact. Solutions are critically needed to expand the biofuels industry into more humid regions or situations where the biomass collection period is limited.

Projects judged to have lower impact attempted to predict future resource allocations or assess future equipment manufacturing needs. Markets will drive the utilization of biomass resources and the ramping up of equipment manufacturing, and BETO efforts could be better focused on short- to medium-term projects that address industry viability. Establishment of demonstration projects such as the North Central Sun Grant Eco-Farm that are unable to sustain long-term operation may increase knowledge and experience, but have limited impact toward the BETO goal. BETO-funded projects focused on genetic improvement of energy crops generally received more divergent scoring from the review team and the long-term impact of those projects is questionable.

Innovation

The bulk of BETO's portfolio projects are based on the application or refinement of known technologies with biomass residues and crops; a strategy appropriate for a program whose intent is to maximize biomass supply at reasonable cost. The majority of the portfolio should

be lower risk/higher probability of success projects. This strategy is working in most cases. However, in instances where the challenges are particularly intransigent, a limited number of higher risk projects should be considered.

Significant innovation has been demonstrated in multiple projects. Of particular note are the following:

- Near-infrared (NIR) sensing techniques for assessing the quality of biomass in bale form
- High tonnage logistics projects awarded from FY 2009 and FY 2013 advanced logistics funding opportunities
- New vehicle design for whole tree transport to facilitate an integrated log merchandising operation.

Topics requiring greater innovation include treatments that could reduce fire potential in stored biomass without affecting the conversion efficiency, non-contact mapping of moisture content variability within bales, and bulk handling and storage of high moisture biomass at or below BETO target costs.

Synergies

Significant levels of synergy within the BETO portfolio were described during the review. Examples include the following:

- The Sun Grant Feedstocks Partnership providing crop yield potentials that were modeled in the PRISM-ELM software and used to conduct *BT16*
- Logistics equipment and systems developed with BETO funding that are facilitating the operations of the Poet and DuPont biorefineries in Iowa
- Interaction between projects at the various DOE national laboratories
- The Biomass Feedstock National User Facility (BFNUF) and the establishment of the FCIC.

Interactions described between the PIs of various projects give additional confidence that synergies are real and effective.

Opportunities remain for increasing synergies within the FSL portfolio and across other BETO program/technical areas, particularly the Conversion R&D Program. Several projects were already part of the FCIC grouping, but specific individual projects were recommended for inclusion in FCIC. Greater synergy could be gained across multiple projects by incorporating the developing biomass quality sensing techniques and providing the capability of utilizing those quality measures in the optimization of the biorefinery or storage strategies.

Focus

The BETO FSL Program has successfully projected future availability of biomass as well as equipment and labor needs to support a biofuels industry of a size to meet the Renewable Fuel Standard (RFS) targets. The challenge facing BETO now is getting a viable industry started and demonstrating the profitability of biofuels sufficiently to attract investment capital. Going forward, the focus of the FSL program should be on solving the short- to medium-term challenges of supplying biomass at sufficient quantity, quality, and delivered cost, and less on projecting longer-term performance. The current portfolio does include projects that address the nearer-term challenges and funding should be reduced for analysis projects (e.g., supply forecasts and analysis; resource mobilization; the Clean Energy Manufacturing Analysis Center [CEMAC], etc.) and enhanced in those projects that directly address issues the industry is facing today (e.g., quality assessment, handling, storing and processing wet biomass, adaptive control systems to enhance capacity of unit operations such as grinding, drying and densification, and systems analysis for the entire stream of unit operations, etc.). Increased attention to the interactions between feedstock logistics and conversion should also be an area of focus. For example, some FSL projects address blending of biomass sources, but it is not clear that conversion processes are optimized with blended feedstock.

The FY 2015 Peer Review cautioned against mission creep, and evidence of that issue was present in some projects. An example is the addition of sugarcane aphid resistance of sorghum to the future work of the US-India Consortium project. A robust review of project activities by BETO staff is needed to detect and respond to such creep.

Commercialization

Relatively few outputs of BETO FSL projects have been commercialized. This is in large part because the cellulosic biofuels industry, and thus the demand for equipment by that industry, has not developed at the rate anticipated by the federal RFS. A number of the projects have produced products with potential for commercialization, and are waiting for a market demand. This is particularly true for the competitively awarded high tonnage logistics projects, which resulted from the FY 2009 and FY 2013 advanced logistics funding opportunities. Projects such as high moisture pelleting and adaptive control of grinding have significant potential for commercialization. However, rapid movement of technical advances into commercial production will need to be based upon auxiliary uses of the technology. Identifying potential uses of BETO developed technology in mature industries can be an effective strategy for ensuring the technology will be available for biofuel industry adoption when that industry does ramp up in size.

During review presentations about the Process Demonstration Unit (PDU) at INL, the Review Team was informed that the PDU is expected to be available to commercial firms for proprietary research on a fee basis, and to conduct BETO-sponsored research. In addition, INL management expressed that BETO wishes the PDU to be more self-supporting. The Review Team recognized a potential conflict between the roles of conducting BETO-directed research and generating income from commercial firms. This dual use of the facility also presents challenges in managing intellectual property (IP) when public and private entities collaborate in a facility. Appropriate strategies for IP management must be in place to support the commercialization of BETO technology.

Recommendations

BETO investments in projects to assess the potential for supplying a biofuels industry and developing the technologies needed to do so have been largely successful. Many lessons have been learned and processes or machines developed. However, much remains to be done if a biofuels industry is to become economically viable. Recommendations for individual projects are made in the summary comments for each, but the following are overall reviewer recommendations for BETO as it sets future objectives.

- Closer and more effective collaboration with USDA in setting priorities for research on biomass crops is needed. The Review Panel is aware that USDA has responsibility for the plant improvement aspects of feedstock development. Significant improvements in biomass crop characteristics are needed beyond yield gains, and BETO must collaborate with USDA—through the National Institute of Food and Agriculture (NIFA) and Agricultural Research Service—by providing desired phenological or chemical characteristics that plant breeders and agronomists should target in their research. The cooperation of USDA to include such needs in funding opportunities and project plans is needed. For example, reduction in lodging of high-yielding energy crops would improve harvest efficiencies and reduce ash content due to soil contamination. The Panel recognizes that cooperation with USDA has been underway for some time, so our recommendation is to continue to place an emphasis on communicating specific research needs that are recognized as enhancing BETO's goals.
- Increase emphasis on addressing the short- to medium-term feedstock and logistics issues that are a drag on biofuel industry efficiency and profitability. The Billion-Ton report series (including *BT16*, the *2011 U.S. Billion-Ton Update*, and the *Billion-Ton Study* published in 2005) have been quite successful in demonstrating the potential size of the bioecon-

omy, and now addressing the sustainability of that industry. Relatively modest value will be gained by continued refinement of that effort. Reallocation of funding from analytical projects to those more likely to stimulate the growth of the industry is needed. A billion-ton biofuels industry will be made up of 1,000 biorefineries processing 1 million tons each. It is more critical to focus on activities that will make those initial biorefineries successful. The industry will never reach a billion-ton demand unless several successful million-ton biorefineries first exist.

- The recommendation for a depot-level demonstration project was made in the FY 2015 Peer

Review. Such a depot demonstration has not been initiated, so the team reiterates the importance of such a demonstration. While the operations of the PDU at INL perform some of the aspects that a depot demonstration would, the experience of operating such a depot for an extended length of time is one of those medium-term issues mentioned in the second recommendation. If BETO feels that it does not have the knowledge and systems in place to conduct such a demonstration, it should clearly identify the aspects that are lacking and identify those projects that are intended to provide the knowledge or systems as addressing the intent for a depot demonstration.

FSL PROGRAMMATIC RESPONSE

Introduction/Overview

The FSL Program would like to thank the 2017 FSL Peer Review Panel members for their service on the Review Panel and for their thorough analyses of the FSL portfolio of projects. We are indebted to the reviewers for their hard work and their objective and knowledgeable comments on the diverse projects that were reviewed.

The Review Panel recognizes the FSL Program's efforts and investments to increase confidence in estimating feedstock availability, energy crop yield, and logistical costs. Since these are important focus areas for the program, we thank the Panel members for recognizing and highlighting the successes of these core efforts, especially BT16, the Regional Feedstock Partnership, and innovation in feedstock technology development, application, and use. Members of the Panel are also complimentary on the synergy among these projects which has been an important goal for the program.

BETO's FSL Program has worked hard, through implementation of active project management principles, to coordinate and facilitate data production, and to ensure that the data are made available to maximize their usefulness. This includes data integration within the supply and logistics components as well as along the entire supply chain. Examples include the Bioenergy Feedstock Library⁴ and the Bioenergy Knowledge Discovery Framework⁵ (KDF). Reviewers also recognize the important role of the FSL Program working with industry. As examples, the reviewers mention the success of an industry equipment development project, FDC Enterprises Inc., in harvest, collection, and transport of biomass bales using an integrated approach. Also highlighted is the success of INL's biomass engineering project—a collaboration with industry partners to reduce moisture and soil contamination in corn stover bales. There are also very favorable comments on the cooperation with various universities across the country to quantify energy crop yields as a function of genetics, geography, and environment (especially soil and weather conditions).

⁴ Visit the Bioenergy Feedstock Library at <http://bioenergylibrary.inl.gov>.

⁵ Visit the Bioenergy KDF at <http://www.bioenergykdf.net>.

The FSL Program welcomes the assessment of the positive impacts in scientific advancements and support of industry development for several projects. We also appreciate the Review Panel's input that some of the projects were much less impactful. Such projects are those that had a focus on future predictions of biomass allocations and equipment needs, or long-term field studies. The Panel suggests that the FSL Program would be better served with short- to medium-term projects that address industry viability. The FSL Program agrees that the focus should be on solving the short- to medium-term challenges of supplying biomass at sufficient quantity, quality, and competitive delivered costs. We also agree to the suggestion to reduce analysis projects, with the exception of such cases where analyses are needed to solve industrial viability challenges and issues.

The FSL Program appreciates the recognition of innovation in the portfolio while relying on known technology much of the time. We agree that there needs to be a mix of low- and high-risk research to achieve truly innovative technology. The effort placed on developing synergy among the projects and with other program areas is also recognized. We appreciate the positive comments as this has been a focus area for the FSL Program. The Panel's suggestions for improving synergy are welcomed.

Commercialization is still an ongoing issue for the FSL Program because of the lack of dynamic market conditions and the inherently slow implementation of new technology. FSL will look at the opportunities for application of such technology in ancillary uses as a way to ensure that the technology will be scaled up for use in the bioeconomy.

Recommendation 1: Increase Collaboration with USDA

Going forward, the FSL Program will work even more to improve communication of research priorities with USDA. We will also look to increase effectiveness of the following ongoing USDA collaborations, specifically

as they relate to crop improvement, production, and management:

- USDA/DOE Biomass Feedstock Coordination Group quarterly meetings
- USDA/DOE national laboratory, research center, and station bioeconomy research collaboration meetings
- Five relevant interagency working groups, with coordination and exchange between two agencies (Feedstock Production and Management, Feedstock Production and Genetic Improvement, Feedstock Logistics, Sustainable Bioeconomy, and Analysis)
- Information exchanges on plant (crop) improvement and yield studies (Regional Feedstock Partnership, feedstock network, and field trials)
- USDA Peer Reviewers on most FSL projects
- Development and execution of the joint US-DA-DOE Biomass R&D Initiative solicitation.

DOE and USDA will continue detail opportunities within each other's agencies, and will continue to take full advantage of the recently established Memorandum of Understanding to foster collaboration between the DOE national laboratories and USDA Agricultural Research Service, which resulted from a DOE employee going on assignment to USDA for 18 months. In addition, the FSL Program will include DOE Office of Science and Advanced Research Projects Agency-Energy in efforts to coordinate with USDA.

Recommendation 2: Emphasize Near-Term Goals

The FSL Program agrees that the primary focus of the program should be developing technologies to make biorefineries successful. With the potential of the bioeconomy well-established and quantified, moving forward, the emphasis will shift from asking "how much biomass is potentially available?" to "how can we mobilize potentially available biomass?"

Future work will now focus on (1) solving the near-term feedstock logistics issues by including and improving productivity, environmental effects, and feedstock quality parameters, and (2) developing preprocessing strategies to address feed handling problems faced by biorefineries in collaboration with the FCIC, with the goal of achieving greater operational reliability and cost targets.

Recommendation 3: Create Depot-Level Demonstration Project

BETO acknowledges and agrees with the need for a depot demonstration. Moving forward, BETO will continue to assess whether depot demonstration projects align

with Administration priorities and are feasible within BETO's appropriations. Currently, demonstration projects do not align with the Administration's near-term priorities for BETO. BETO will conduct early stage R&D toward quality specifications and understanding fundamentals of feedstock preprocessing and handling. This will support industry in building on the knowledge for demonstration and scale-up activities.

In addition, INL's PDU capabilities will be leveraged to address feedstock handling and feeding problems, and the obtained unit operations specifications will continue to provide valuable information to integrate into FCIC and depot demonstration.

SUPPLY FORECASTS AND ANALYSIS

(WBS #: 1.1.1.1)

Project Description

Realization of a bioeconomy vision is dependent upon biomass feedstock supplies. The economic viability of a biomass-based industry depends on feedstock quantity, quality, cost, and spatial and temporal distribution, as well as variability in these characteristics. This project provides data on the potential economic availability of biomass feedstocks. These data are critical to other R&D efforts in BETO and are used by other agencies and stakeholder groups. This effort employs an economic modeling framework (e.g., POLYSYS) to project county-level estimates of potential biomass supplies (e.g., agricultural residues, dedicated biomass feedstocks, and forest resources) as a function of price, scenario, and year. Ongoing modeling efforts include maintenance of current underlying data, incorporating

Recipient:	Oak Ridge National Laboratory
Principal Investigator:	Matt Langholtz
Project Dates:	10/1/2006–9/30/2017
Project Category:	Ongoing
Project Type:	Annual Operating Plan
DOE Funding FY 2014:	\$950,000
DOE Funding FY 2015:	\$1,750,000
DOE Funding FY 2016:	\$2,200,000
DOE Funding FY 2017:	\$1,900,000

up-to-date biomass crop yield and budget assumptions, adding additional feedstock types such as algae and MSW, evaluating reactor-throat-delivered estimates, and quantifying environmental sustainability impacts. Detailed results are disseminated through the KDF. This project produced BT16, including *Volume 1: Economic Availability of Feedstocks* and *Volume 2: Environmental Sustainability Effects of Select Scenarios from Volume 1*, along with online companion material on the Bioenergy KDF (bioenergykdf.net).

Weighted Project Score: 8.2

Weighting: For ongoing projects, there is equal weighting across all four evaluation criteria: Approach, Relevance, Accomplishments and Progress, and Future Work.

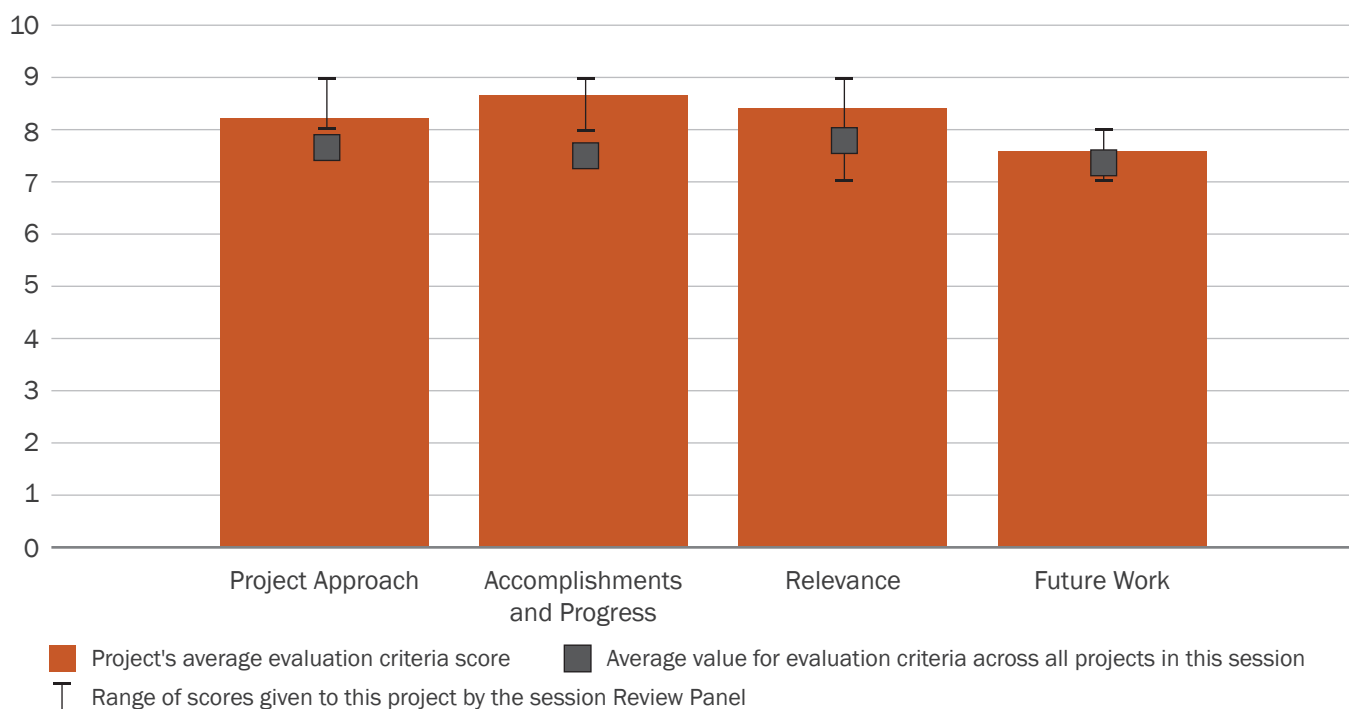

2040, \$60/dt, Base Case

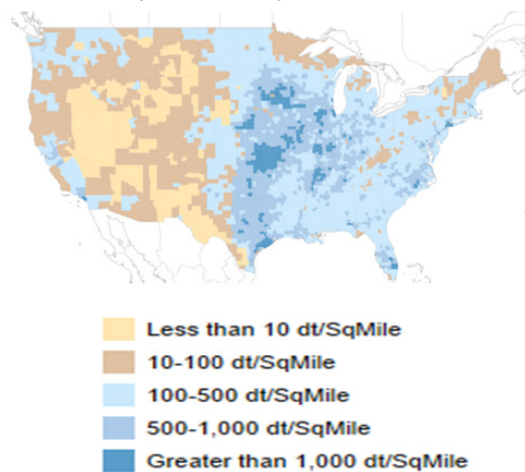

Overall Impressions

- My overall impression is that this project continues to make amazing strides and advance the state of the art. It is truly impressive and valuable, and guides academic work priorities. In the future, this project needs to
 - Incorporate more nuanced and validated crop productivity and environmental impact data
 - Express results as a function of the status quo for fossil and commodity crops so the public and decision makers can realistically compare systems performance.
- This is a very significant and comprehensive approach to estimate and establish the availability of the biomass resources for the biorefinery industry. The sustainability component is an interesting development, but it needs very clear objectives to ensure this component adds value to the program.
- This project needs to include social aspects/social indicators on modeling.
- This is a well-done project has been a major contributor to *BT16* volumes 1 and 2 by identifying the supply and economic availability to the reactor throat at a county level and addressing the sustainability criteria of many feedstocks.
- The sustainability assessment is the first step in identifying and understanding its benefits. The sustainability assessment is mainly focused on the environmental indicators. Social indicators need to be developed and vetted for its applicability to various biomass crops. Despite criticisms on the accuracy and the credibility of sustainability indicators, they could serve as a decision support tool to develop mitigation strategies and long-term environmental issues/benefits of locally grown biomass crops. BETO needs to determine how best to use the sustainability assessments in its role as an advocate for the biofuel industry.
- Overall, the project has accomplished key milestones related to the national biomass supply analysis study to demonstrate the wealth of biomass availability in the nation to build a strong and emerging bioindustry in the United States. The vast availability of low-cost feedstock has demonstrated the strength of our bioeconomy, while addressing key feedstock quality and cost risks. The project has a potential to address key biomass quality parameters within the assessment as required by the biorefinery.

PI Response to Reviewer Comments

- We agree that the crop productivity and environmental effects data can and should be improved. We agree that a “compared to what” analysis would elucidate comparative advantages of system performance, and will do so as programmatic goals allow.

We agree that social indicators can and should be added, and that results can and should be used in decision support tools to develop mitigation (or benefit maximization) strategies. To provide more benefit to end users, we agree that more feedstock quality parameters should be added to the analysis.

FEEDSTOCK SUPPLY CHAIN ANALYSIS

(WBS#: 1.1.1.2)

Project Description

Today’s infant biorefinery industry lacks a consistent and reliable biomass supply, and thus relies on vertical integration of its feedstock supply to minimize supply risk. However, the existing biomass supply is collected and supplied using conventional feedstock supply systems developed for industries that are less sensitive to feedstock quality and can thus utilize lower cost passive quality management. The overarching goal of this project is to provide BETO with credible, objective analyses of feedstock supply systems and strategies to support their investment in a sustainable, economically viable national scale bioenergy industry. This project

Recipient:	Idaho National Laboratory
Principal Investigator:	David Thompson
Project Dates:	10/1/2006–9/30/2017
Project Category:	Ongoing
Project Type:	Annual Operating Plan
DOE Funding FY 2014:	\$450,000
DOE Funding FY 2015:	\$585,000
DOE Funding FY 2016:	\$765,000
DOE Funding FY 2017:	\$900,000

directly informs BETO through barrier “Ft-M: Overall Integration and Scale-Up” in the MYPP.⁶

This project develops and vets innovative strategies that meet cost, quantity, and quality specifications while minimizing environmental impacts, and delivers robust datasets and flexible analysis tools to enable industry to implement a successful biofuel supply system. This project also tracks progress toward the \$84/ton modeled feedstock cost target, based on technology improve-

Weighted Project Score: 8.2

Weighting: For ongoing projects, there is equal weighting across all four evaluation criteria: Approach, Relevance, Accomplishments and Progress, and Future Work.

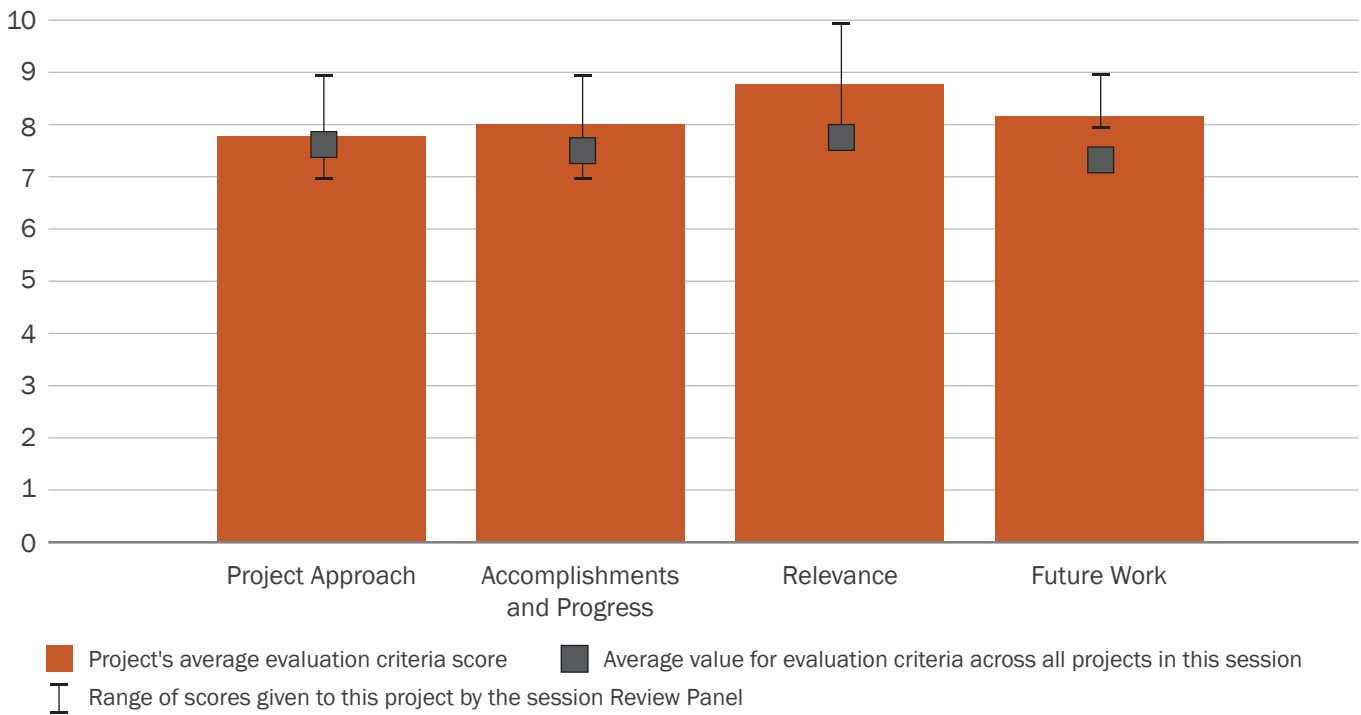

⁶ U.S. Department of Energy, Bioenergy Technologies Office (BETO), *Multi-Year Program Plan* (BETO, March 2016), https://www.energy.gov/sites/prod/files/2016/07/f33/mypp_march2016.pdf.

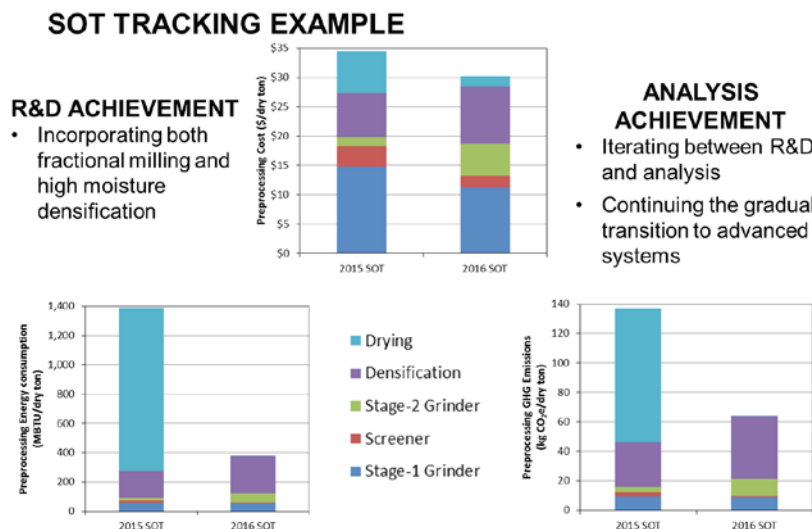

ments identified annually in R&D activities. Historically, we have investigated conventional feedstock supply systems and several advanced (active quality management) feedstock supply system strategies including blending and commoditization of biomass to meet modeled cost, quantity, and quality specifications required to meet long-term U.S. biofuels production goals.

Overall Impressions

- This is a foundational project that evaluates effectiveness of BETO projects toward meeting BETO goals.
- Good model to measure and validate the progress of the program activities and to help in the decision-making process. As result of the analysis, there are a significant number of assumptions in the analysis and the tool that could benefit from a risk component to help define the uncertainty of the results.
- Provides guidance to BETO R&D. Confidence in selecting/evaluating new technologies is crucial.
- This is a good line of research that provides verification to track BETO's goals and guide R&D.
- This project provides fundamental analysis for BETO management that allows assessment of progress on the larger goals of the program. As such, this

is a critical function that must be maintained within the program. That being said, the results presented can be criticized on several points. The analyses seem to indicate that BETO is being successful in meeting cost targets for delivered biomass, but the industry reality is that such targets are not being met. This leaves several questions, including the following: Are the modeled assumptions being too optimistic? The data presented gave only single value estimates at each point in time. What about including variance on the state-of-technology (SOT) estimates? Adding uncertainty to each of the number used in the analysis will certainly complicate the analysis, but would provide a better understanding of the real confidence in the estimates.

- Overall, the project has demonstrated that advanced supply logistics system could reduce the feedstock delivered cost to a target level, without compromising the quality of biomass. The future research will be carried forward in the right direction to improve feedstock quality reliability and reduce risks.

PI Response to Reviewer Comments

- In line with the conversion techno-economic analyses (TEAs), our design cases and SOTs present nth-plant scenarios that assume that all of the operational issues have been overcome, rather than the first-plant scenarios experienced by the pioneer

biorefineries. Beginning with our March 31, 2017 Go/No-Go Decision Point, in which we look at the impacts of reduced operational reliability due to feedstock properties, we have initiated this type of analyses. This analysis has allowed us to target fines generation and moisture content as the feedstock properties having the most impact on achievable throughput; while this is not the only issue experienced by the pioneer biorefineries, it is a significant one and we are working toward a solution.

Regarding uncertainty, this is a good comment, and we began integrating uncertainty analyses around assumptions in FY 2017. Unfortunately, while possible in the Biomass Logistics Model, Monte Carlo analyses are unwieldy and difficult to complete. To alleviate this limitation, we built Aspen Plus modules for the preprocessing operations during the first 4.5 months of FY 2017 (using the same experimentally-derived relationships among energy consumption, moisture content, etc. measured in the INL PDU) to allow the Monte Carlo analyses to be done more easily.

RENEWABLE ENHANCED FEED-STOCKS FOR ADVANCED BIOFUELS AND BIOPRODUCTS (REFABB)

(WBS#: 1.1.2.2)

Project Description

Production of polyhydroxybutyrate (PHB) in switch-grass enables small-scale thermolysis facilities to produce crotonic acid and densified biomass. Densified biomass can be transported to large-scale biofuel facilities or used directly as fuel. Crotonic Acid can be converted to butanol. The project addresses three key technology barriers, feedstock supply, feedstock logistics and cost-effective biomass conversion. This project adds to our understanding of the potential of developing a value-added biomass feedstock crop for bioproducts and biofuels.

Recipient:	Yield10 Bioscience
Principal Investigator:	Oliver Peoples
Project Dates:	9/1/2011–2/28/2016
Project Category:	Sun-setting
Project Type:	FY 2010–BRDI: DE-FOA-0000341
Total DOE Funding:	\$6,000,001

Challenges in demonstrating conversion of PHB in biomass to crotonic acid at over 90% yield illustrates the limitations of trying to adopt existing equipment to a task for which it proved unsuitable, resulting in the project not being able to demonstrate a scalable economic process. Solving this will take further R&D work. Novel genetic engineering technologies were developed and PHB levels in switchgrass were increased up to 10%. Scalable conversion of crotonic acid to butanol was demonstrated and a lifecycle analysis completed. Genes for increasing photosynthesis were patented and are now being developed to enhance food crop production by Yield10 Bioscience.

Weighted Project Score: 7.2

Weighting: Approach–25%; Relevance–25%; Accomplishments and Progress–50%.

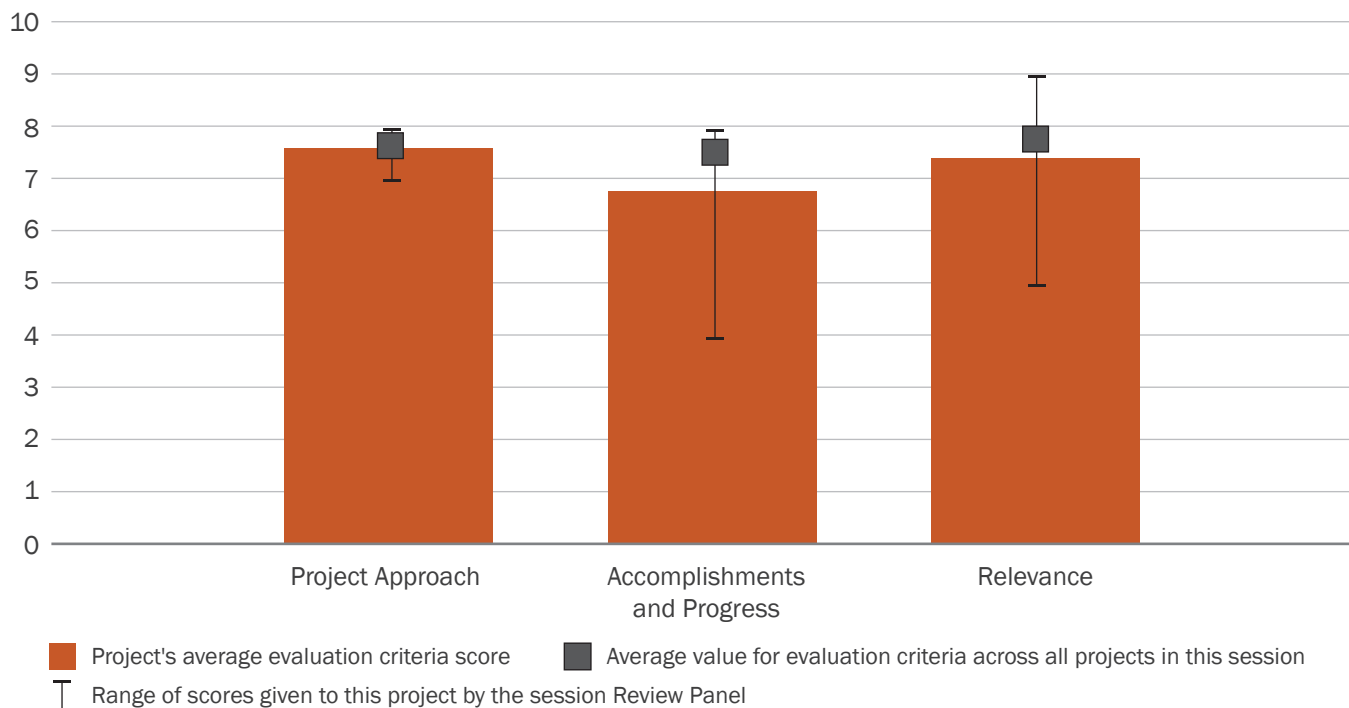

Overall Impressions

- This project is very ambitious and high risk. Major progress was made, but ultimately this project demonstrated the extreme challenges associated with switchgrass molecular breeding and coupled feedstock/processing improvement. Techniques used here are too time and resource intensive to test all the interactive components of the system needed to make progress. Exemplary project to illustrate limitations of molecular breeding paradigm.
- The project advanced the state of the art of chemical production in plants. FSL should determine if this pathway will be continued in the future.
- Great project and ideas. Overly achieving objectives. Disappointed not to see some of the technologies moving forward.
- This seems like a good time to end this project. Laboratory experiments were informative; however, it does not seem like this is a promising avenue for co-product production that will help get the biofuel industry off the ground.
- This is a high risk/high reward project that was perhaps too ambitious. Some of the planned tasks were dropped because of lack of adequate progress. For those tasks completed, achievements relative to the critical success factors was minimal, and the project contractor has abandoned any work with biomass feedstocks. Advances in genetic manipulation that may be significant in other applications were accomplished, but the value to BETO was minimal. Greater integration with other projects addressing the bio-factory concept was needed.
- Overall, the project has successfully demonstrated that the genomics may be a path toward failure for successful establishment of bioenergy industries in the United States. The project could not overcome all technical barriers related to efficient extraction of biopolymer from plant biomass in order to be economically successful in the near future. However, the technical advancements related to genomics of energy crops are innovative and could be adapted by other food/feed or pharma industries.

PI Response to Reviewer Comments

- No official response provided at time of report publication.

BIOMASS ENGINEERING

(WBS#: 1.2.1.1)

Project Description

Results from the current integrated biorefineries and prior research at INL have demonstrated the negative impact of moisture and soil content in baled biomass. Impacts include biological degradation, displacement of valuable carbohydrate by soil, and increased preprocessing and handling costs for high-moisture and soil-laden biomass. Best management practices have gone only so far in reducing the bale-to-bale variations in moisture and ash seen in commercially harvested stover. Active management is needed to further reduce these unwanted variations. Timely information is necessary to make decisions that impact moisture and soil content during harvest and to deliver biomass to the biorefinery in a way that reduces day-to-day variations that affect preprocessing and conversion operations.

Recipient:	Idaho National Laboratory
Principal Investigator:	Bill Smith
Project Dates:	10/1/2006–9/30/2017
Project Category:	Ongoing
Project Type:	Annual Operating Plan
DOE Funding FY 2014:	\$1,100,000
DOE Funding FY 2015:	\$1,185,000
DOE Funding FY 2016:	\$1,190,000
DOE Funding FY 2017:	\$1,190,000

This project will identify and adapt robust analytical tools to evaluate moisture and soil content in baled stover and provide a coarse measurement that enables harvesters to reduce soil contamination. The project will also allow biorefineries to schedule delivery of biomass of known moisture and soil content to blend the highs and lows and reduce daily variations at the plant. By 2018, the project team aims to accomplish the following goals: (1) demonstrate in-field and on-equipment tools to measure and reduce soil contamination in stover bales, and (2) produce an example of an actively

Weighted Project Score: 8.5

Weighting: For ongoing projects, there is equal weighting across all four evaluation criteria: Approach, Relevance, Accomplishments and Progress, and Future Work.

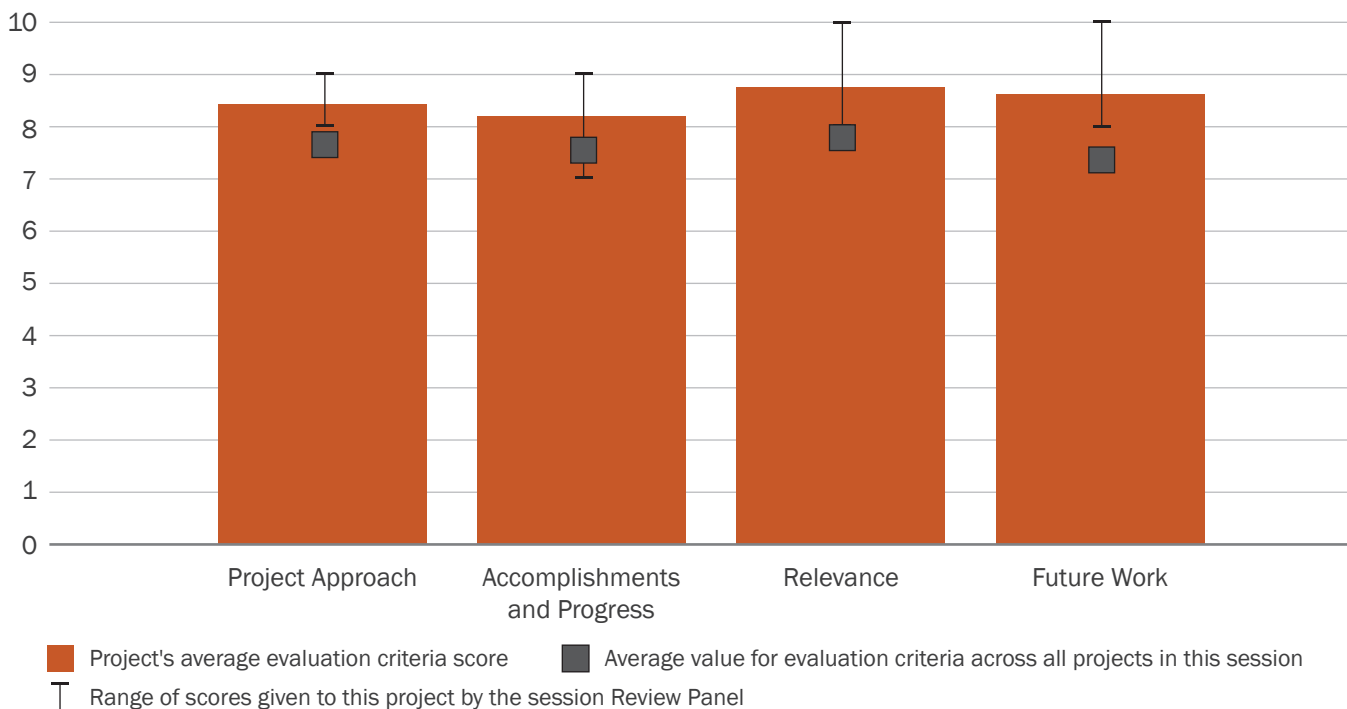



managed queuing system that predicts dry matter loss and moisture content in stacked stover bales based on storage method and ambient weather conditions.

Overall Impressions

- This is a very practical project that directly addresses the information needs of biorefineries. It can directly reduce risk for the pioneer cellulosic ethanol biorefineries. Good collaboration with industry. Would like to see how this corn stover work supports other feedstocks.
- This work is essential to advance the state of the art and optimize the harvesting and storage of biomass to increase the quality and develop strategies to lower the ash and moisture content of the biomass.
- Great approach for having *in-situ* NIR technologies. Research work is valuable for developing new and improved methodologies for measuring ash, sugars in biomass during harvesting and storage to monitor biomass quality.
- Excellent project trying to tackle a complicated issue using the expertise of national laboratory and industry partners.
- The development and advancement of sensing technologies for biomass quality assessment is needed

for the developing biofuels industry. It is clear that the ability to accurately assess the quality of biomass will be needed to support an efficient market that can establish prices based on quantity and quality, as well as process control needed in biorefineries. To date, the project has focused on corn stover.

As the project moves forward, it should incorporate other feedstock types. A strong understanding of the influences of biomass species and variety, maturity level, and harvest methods on the accuracy of NIR measurements of moisture, ash, and other quality parameters is needed. As would be appropriate for any project on assessing quality parameters, both accuracy and repeatability of the estimates must be determined and reported. Models developed should have as outputs both a best estimate and the uncertainty level of that assessment.

- Overall, the project has highlighted technical challenges with the existing feedstock delivery system affecting the biomass quality and its implication to downstream conversion processes. The project has made significant progresses to address major technical issues. The project should consider developing best management practices that preserve the quality of biomass feedstock that can be delivered to a biorefinery for smooth operation.

PI Response to Reviewer Comments

- The project team thanks the reviewers for their encouraging and constructive feedback. Several topics received multiple reviewer comments, such as establishing best management practices, analysis validation at commercial sites and scale, and evaluation of biomass resources beyond corn stover. This task has evolved since its inception from evaluating existing harvest and collection systems and practices to efficiently meet corn stover and other biomass supply quantities and costs (FY 2011–FY 2013), to quantifying the economic impact of important qualities such as moisture and ash content early in the supply chain (FY 2015), and recently has focused on methods to detect moisture and ash in baled biomass prior to delivery.

Our experience is that passive efforts such as best management practices have gone only so far toward reducing problems associated with ash (soil contamination) in harvest and moisture (dry matter loss) in storage.

We believe that active management early in the supply chain is needed to address the immediate problems of moisture and ash. Active management requires rapid evaluation and access to the results in time to change

the process—harvest, baling, or storage—to preserve the biomass’ inherent value to the end user. These rapid methods need to balance accuracy with speed, sensitivity with value, and do so with equipment and methods that are sufficiently robust to withstand use in a commercial biomass supply chain.

Our 1st-year efforts have been to select a subset of existing analytical methods to extend into the field. As we down-select we will, as the reviewers suggest, evaluate the accuracy and repeatability of these methods first in the laboratory and later in commercially-relevant conditions. Our work has started with corn stover for several reasons, including the following: (1) current integrated biorefineries rely on this resource; (2) it is abundant and makes up a large portion of the available herbaceous biomass in the United States now and into the future; and (3) it typifies the industry’s current problems related to ash/soil contamination during harvest, material losses related to storage moisture, and biomass variability (moisture, ash, and carbohydrates) as it relates to industrial scale preprocessing and conversion. Ultimately, we will extend these methods—where applicable, as not all resources have the same quality-related challenges—to other biomass resources in the future.

DEVELOPMENT OF A WET LOGISTICS SYSTEM FOR BULK CORN STOVER

(WBS#: 1.2.1.1000)

Project Description

This project evaluates centrally located wet biomass storage and the enabling logistics operations at an industrial scale to control logistics costs, preserve feedstock value in wet climates, and reduce the risk of fire. This project also enables mobilization of the high-moisture portions of the nation’s billion tons of biomass, which includes over 50% of available corn stover. The technical approach is based on TEA of the wet logistics system through (1) harvest, collection, and transportation costs obtained using the INL Biomass Logistics Model; (2) an engineering design detailing unit operations and associated costs of large scale biomass storage at a refinery gate; and (3) laboratory storage performance for two

Recipient:	Idaho National Laboratory
Principal Investigator:	Lynn Wendt
Project Dates:	10/1/2015–9/30/2017
Project Category:	Ongoing
Project Type:	Annual Operating Plan
DOE Funding FY 2014:	\$0
DOE Funding FY 2015:	\$535,000
DOE Funding FY 2016:	\$667,250
DOE Funding FY 2017:	\$385,000

wet storage approaches, industrial-scale ensiling, and modified Ritter storage.

A go/no-go decision based on TEAs selected industrial-scale ensiling as cost competitive with the 2015 target for three-pass stover in a dry system. A field demonstration of anaerobic storage for wet corn stover was completed in coordination with an industrial partner. Corn stover (40% moisture) was harvested using common forage industry methods, and a 300-dry ton drive-over pile was constructed, covered, and stored for 6 months. Dry matter loss averaged <5%, compared to the target

Weighted Project Score: 8.2

Weighting: For ongoing projects, there is equal weighting across all four evaluation criteria: Approach, Relevance, Accomplishments and Progress, and Future Work.

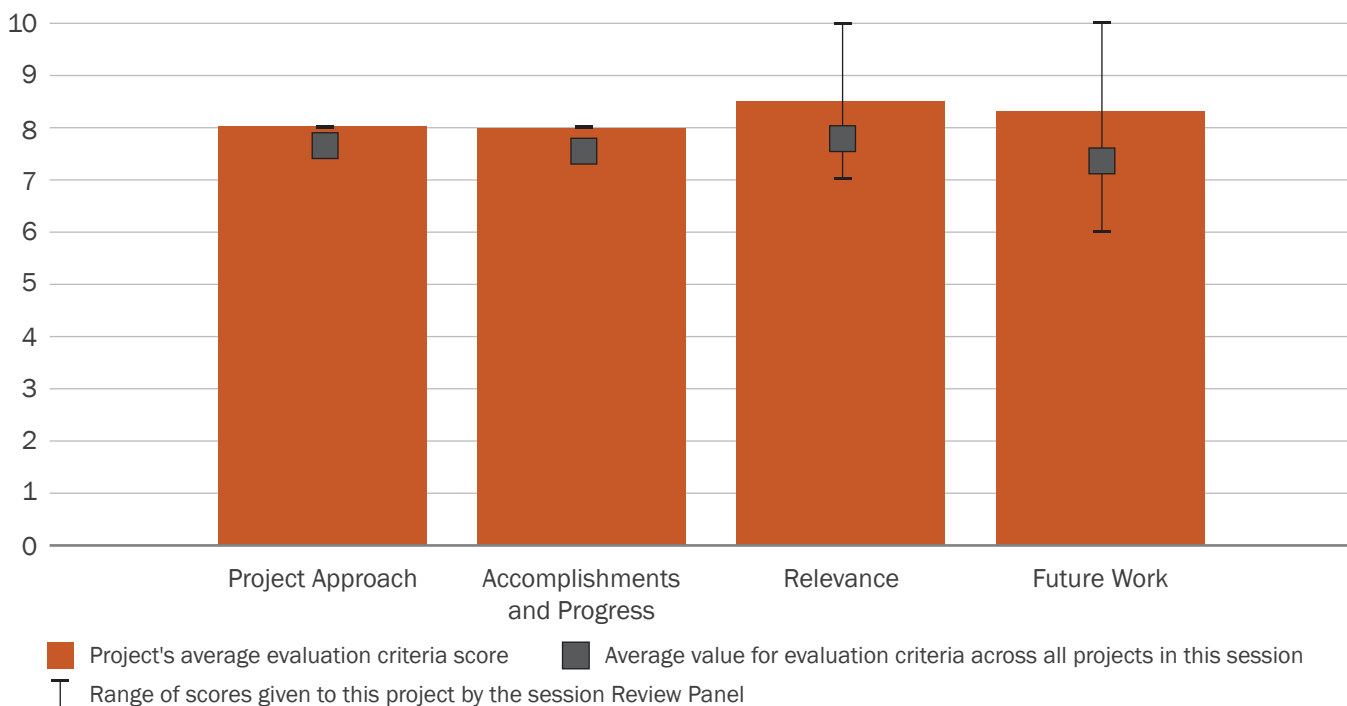
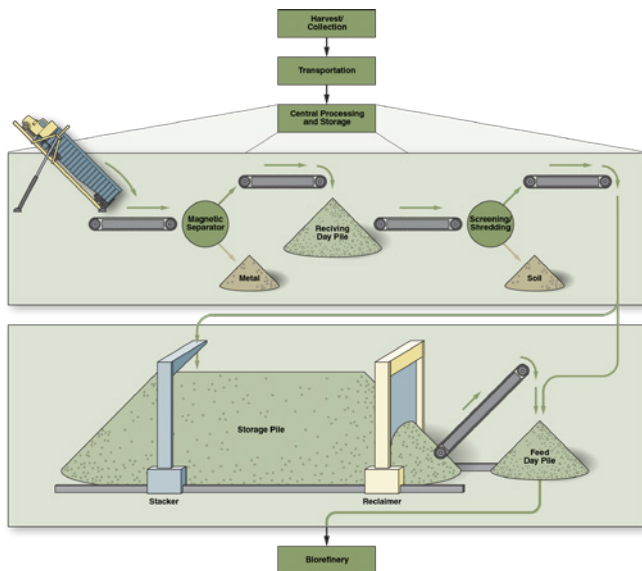

Photo Courtesy of Idaho National Laboratory



of 12% loss for corn stover in the dry logistics system. This work has successfully developed a cost-competitive logistics system for high moisture corn stover.

Overall Impressions

- Overall, this project is addressing baseline performance of wet storage, and has identified metrics to assess and choose wet storage methods. The work is useful and future work is on target, assessing biomass sorghum where this system is likely to be more advantageous than in corn stover.
- Project team needs to define safety risks associated with such systems, perform social-economic impact analysis, and integrate work with USDA. Great collaboration with national laboratories.
- This is an innovative project with many results comparing cost, water use, and energy use of wet and dry storage of stover. Well done. It would be really interesting to expand this project to include other feedstocks expected to have high moisture content for at least the techno-economic analysis.

- The examination of storage methods for wet biomass is a response to a suggestion in a previous project evaluation of a gap in BETO strategies, and a recognition that a significant portion of the billion-ton biomass requirement result in material collected at moisture levels above 20%. This will be especially true for biomass sorghum and energy cane. The examination of alternative methods and identification of the superior choice between the two alternatives examined represents significant progress. Further study is needed to get the costs down to make the system competitive with baling systems.

This project is contributing to BETO goals and should be continued. Future work should include expanding the number of crops stored to determine if the approach is equally suitable for stover, sorghum, switchgrass, or energy cane. The high cost of transporting chopped material from the field to storage is well-known, so alternatives that minimize the distance traveled, or increase the density during transport should be considered. Alternative configuration for anaerobic storage might be considered. The potential for chemical pretreatment during the anaerobic storage should be examined. Comparison of alternatives should incorporate both the logistics costs and biomass quality change during storage. This project should be a part of the FCIC portfolio.

- The project is focused on investigating the technical feasibility of wet storage biomass system. It has demonstrated that the wet storage system has doubled the cost of a conventional storage system. Although the wet storage system has some cost and technical issues, the benefits to pretreatment of biomass should be identified. The project has some potential to de-risk feedstock deconstruction issues for the Biochemical Conversion R&D Technology Area.

PI Response to Reviewer Comments

- We thank the reviewers for the encouraging feedback regarding this work. The focused research on wet logistics systems for corn stover has shed light on multiple opportunities for additional cost reduction to consider in the future. We agree that wet logistics systems should be expanded to include energy crops, which are often harvested at moisture contents exceeding 50% (wet basis) and do not readily dry in the field, as in the case of biomass sorghum, or often need to be harvested earlier in the season at high moisture contents due to difficulties getting into the field in wet years, as can be the case with switchgrass. Energy crops have an advantage over corn stover in that they have high yields per harvested acre and would be able to fulfill the feed-

stock requirements for a biorefinery with a reduced draw radius compared to corn stover, resulting in reduced transportation distances and associated costs. Energy crops also present a challenge, as the soluble sugars at the time of harvest may be higher than corn stover, and these sugars must be preserved in order to contribute to biofuel production.

- We have demonstrated in this project, through laboratory and field studies, that wet, anaerobic storage can successfully preserve high moisture biomass. We will continue to look for ways to lower the costs of wet logistics systems so they are competitive with dry bale systems, for example by reducing transportation costs, preserving soluble and structural sugars in storage, and realizing the potential for pretreatment during wet storage.

SIZE REDUCTION, DRYING AND DENSIFICATION OF HIGH MOISTURE BIOMASS

(WBS#: 1.2.1.2)

Project Description

More than 50% of the biomass in the United States is at moistures >30% (weight basis). High preprocessing costs and poor flow properties limit their use for biofuels production. Developing cost-effective solutions is critical to utilize these biomasses for biofuel production. The goal of this project is to reduce preprocessing costs by 50% compared to the 2013 SOT and support the DOE feedstock cost of \$84 /dry ton. Our technical approach uses fractional milling, high moisture pelleting process, and low temperature drying to reduce the preprocessing cost. In fractional milling, bigger screens are used in the stage-1 grinder, and a separator is inserted between stage-1 and 2 grinders to bypass the fraction that has met the specification.

Recipient:	Idaho National Laboratory
Principal Investigator:	Jaya Tumuluru
Project Dates:	10/1/2015-9/30/2017
Project Category:	Ongoing
Project Type:	Annual Operating Plan
DOE Funding FY 2014:	\$1,500,000
DOE Funding FY 2015:	\$1,450,000
DOE Funding FY 2016:	\$1,232,500
DOE Funding FY 2017:	\$1,232,500

FY 2016 studies reduced the grinding costs to \$14.5/ dry ton for 0.25-inch screen size specification. In high moisture pelleting, biomass is pelleted at moistures >20%. The major advantage is that biomass loses some moisture due to heat generated in the pellet die, and the high moisture pellets produced can be dried using grain dryer. In FY 2016 high moisture pelleting was demonstrated on pilot-scale ring die pellet mill and pellet density and durability targets (>480 kg/m³ and >95 %) were met. Fractional milling and high moisture pelleting resulted in about 17% moisture losses in the biomass. Based on TEA, the cost to pelletize corn stover is reduced to

Weighted Project Score: 8.3

Weighting: For ongoing projects, there is equal weighting across all four evaluation criteria: Approach, Relevance, Accomplishments and Progress, and Future Work.

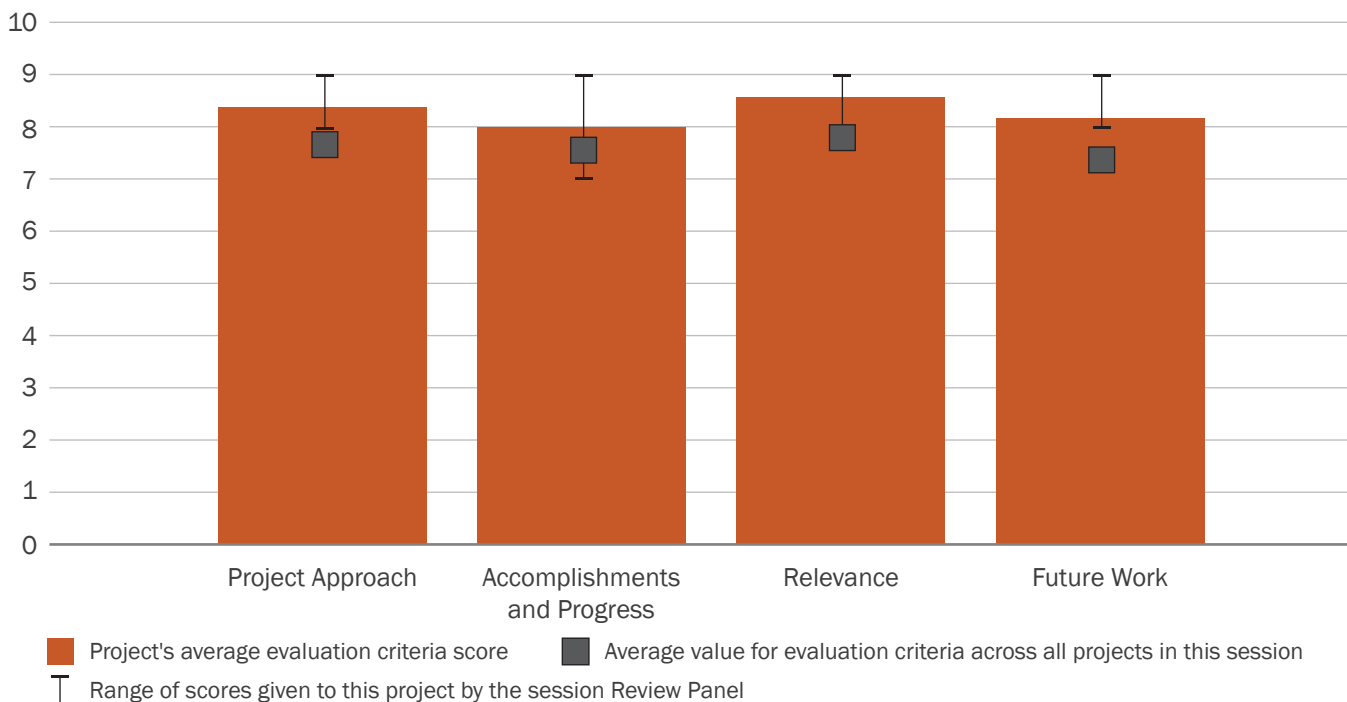

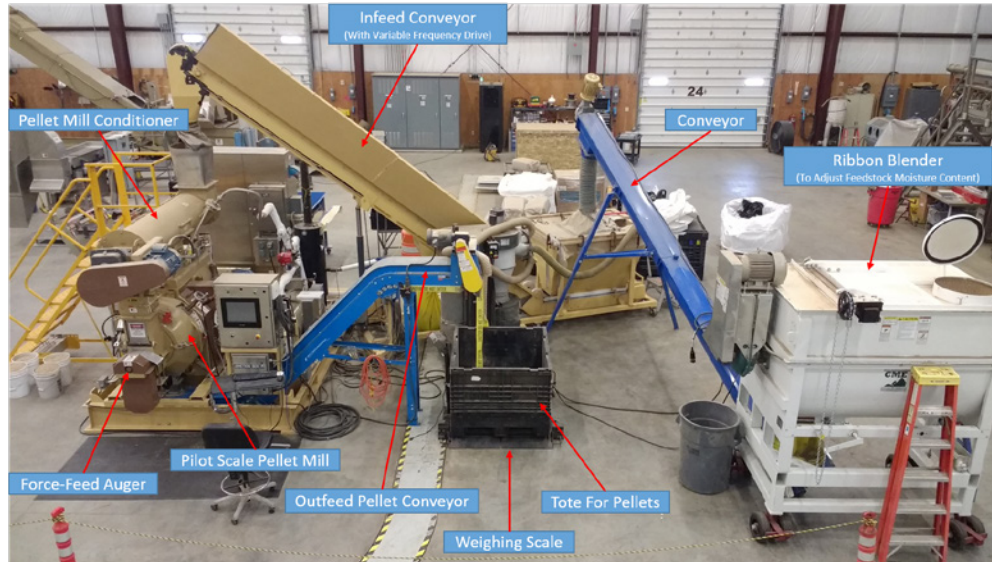

\$25.35/ dry ton, this is lower than the cost established for a 1-inch grind (\$25.67/ dry ton).

Overall Impressions

- My overall impressions of this work are that it provides predictive relationships that enable pelleting of higher moisture biomass while minimizing energy use and cost. Publicly available information supports the industry and saves them costly trial and error.
- The trade-offs of pelletization should be clearly defined to establish the viability of the concept on different conversion processes and biomass types. The benefits are dependent on the conversion process and the type of biomass.
- Great to see cost reduction. However, process evaluation with other feedstock materials/blended materials (higher lignin content, ash content) is needed.
- This is a good project with lots of results and progress made to meet preprocessing price reduction goals. However, this is an existing process used in forestry therefore it isn't really new technology. Please clearly explain the limits to cost reduction if new technology is not developed and this framework continues.
- Examination of the potential for pelleting high moisture biomass is part of the BETO strategy of developing pathways for handling feedstocks as they

are available from the field. This project has made considerable progress on evaluating SOT for pelleting high moisture feedstock. Significant energy savings over conventional pelleting operations were identified, but further validation of the claimed energy requirement in grinding high moisture feedstock using large screen-size is needed. The ability to store high moisture pellets without mold/fungal growth will need to be demonstrated. The project worked with reconditioned materials at 30% moisture. Real world situations will result in 30%–50% moisture material, so this project should expand the range of material (type, moisture level, quality) considered. This project addresses BETO's goals, and should be continued.

PI Response to Reviewer Comments

- This project has looked in understanding the effect of bigger screens in stage-1 and 2 grinders. The results indicated that a bigger screen size of 3 inches in Stage 1 and bigger screen size in Stage 2 (7/16 inch) using fractional milling has reduced the grinding energy by about 65% compared to conventional Stage 1 and Stage 2 grinding process fitted with 2-inch and ¼-inch screens. This will be verified in the integrated demonstration of the process at commercial scale, which is scheduled for September 2017.

- The high-moisture pelleting process tested in this project makes biomass drying optional. If the pellets have to be stored for a short time and be transported short distances drying can be avoided. If the pellets have to be stored for long durations and be transported to long distances, the low temperature drying technologies such as grain or belt dryer can be used to reduce the final moisture content of the pellets to <9% for safe storage to avoid mold or fungal growth.
- The studies on high moisture pelleting were done using reconditioned material and high-moisture bales. The trends observed for both the material in terms of product properties and energy consumption was similar.
- Our integrated design report⁷ deals with biomass bales at 50% moisture content. The storage task (WBS: 1.2.1.1) work is focused on finding cost-effective means to deliver corn stover bales at a maximum moisture content of 30%, via storage conditions that actively or passively reduce the moisture content over time in storage. Therefore, in this project preprocessing has to deal with biomass bales at 30% moisture content.
- We have tested pellets in fast pyrolysis and biochemical conversion. This testing has identified that the fines generated during pelleting can be a problem. Future work is aimed to address this issue which will involve additional testing to understand the viability of the concept on different conversion processes and biomass types.
- Pelleting is not a new technology, but biorefineries are not ready to use the pelleting process currently used in the industry due to high preprocessing cost. In this project we developed a new method which operates at different process parameters, and order of unit operations to produce pellets. This new process was demonstrated at pilot scale (1 ton/hour). TEA of the new process developed indicated that the cost of pelleting is reduced by 62% compared to current technology,⁸ which is commonly used in pellet industry.

⁷ Kevin L. Kenney, Kara G. Cafferty, Jacob J. Jacobson, Ian J. Bonner, Garold L. Gresham, J. Richard Hess, Leslie P. Ovard, et al., Feedstock Supply System Design and Economics for Conversion of Sugars to Hydrocarbons, (Idaho Falls, ID: Idaho National Laboratory, September 2013), INL/EXT-13-30342, <https://bioenergy.inl.gov/Reports/Design%20Case%202017.pdf>.

⁸ Patrick Lamers, Mohammad S. Roni, Jaya S. Tumuluru, Jacob J. Jacobson, Kara G. Cafferty, Jason K. Hansen, Kevin Kenney, Farzaneh Teymouri, and Bryan Bals, "Techno-Economic Analysis of Decentralized Biomass Processing Depots," *Bioresource Technology* 194 (2015): 205–213, <https://doi.org/10.1016/j.biortech.2015.07.009>.

RESOURCE MOBILIZATION

(WBS#: 1.2.1.5)

Project Description

This project investigates the dynamics and growth opportunities in current and emerging U.S. feedstock markets via business-to-business market information and econometric analysis to identify pathways for biomass resource mobilization. As U.S. biofuels industry representatives concluded in a DOE workshop, markets are a primary driver to enable a future billion-ton U.S. bioeconomy. In feedstock markets, processing is a requirement to achieve product fungibility. With the current lack of demand from U.S. biorefineries, alternative markets to biofuels, such as animal feed or biopower, are required to build out U.S. feedstock processing capacity, which increases the amount of resources available to the market. This increases supply security beyond individual farmer contracts, which, according to finance sector officials, is a prerequisite to access financ-

Recipient:	Idaho National Laboratory
Principal Investigator:	Patrick Lamers
Project Dates:	1/25/2010–9/30/2017
Project Category:	Ongoing
Project Type:	Annual Operating Plan
DOE Funding FY 2014:	\$160,000
DOE Funding FY 2015:	\$255,000
DOE Funding FY 2016:	\$255,000
DOE Funding FY 2017:	\$255,000

ing for conversion facilities. A specific focus of the project is to evaluate the risks and benefits commoditization and trade of domestic resources may have on future domestic supply quantities and prices. Leveraging existing modeling expertise at INL and collaborators at other U.S. national laboratories and partner universities, the project quantifies the impacts of current alternative and future competing feedstock uses to biofuels, supporting a respective BETO MYPP milestone. It also provides feedstock market intelligence to related BETO efforts (e.g., *BT16*, Biomass Scenario Model) to strengthen respective scenario developments.

Weighted Project Score: 6.8

Weighting: For ongoing projects, there is equal weighting across all four evaluation criteria: Approach, Relevance, Accomplishments and Progress, and Future Work.

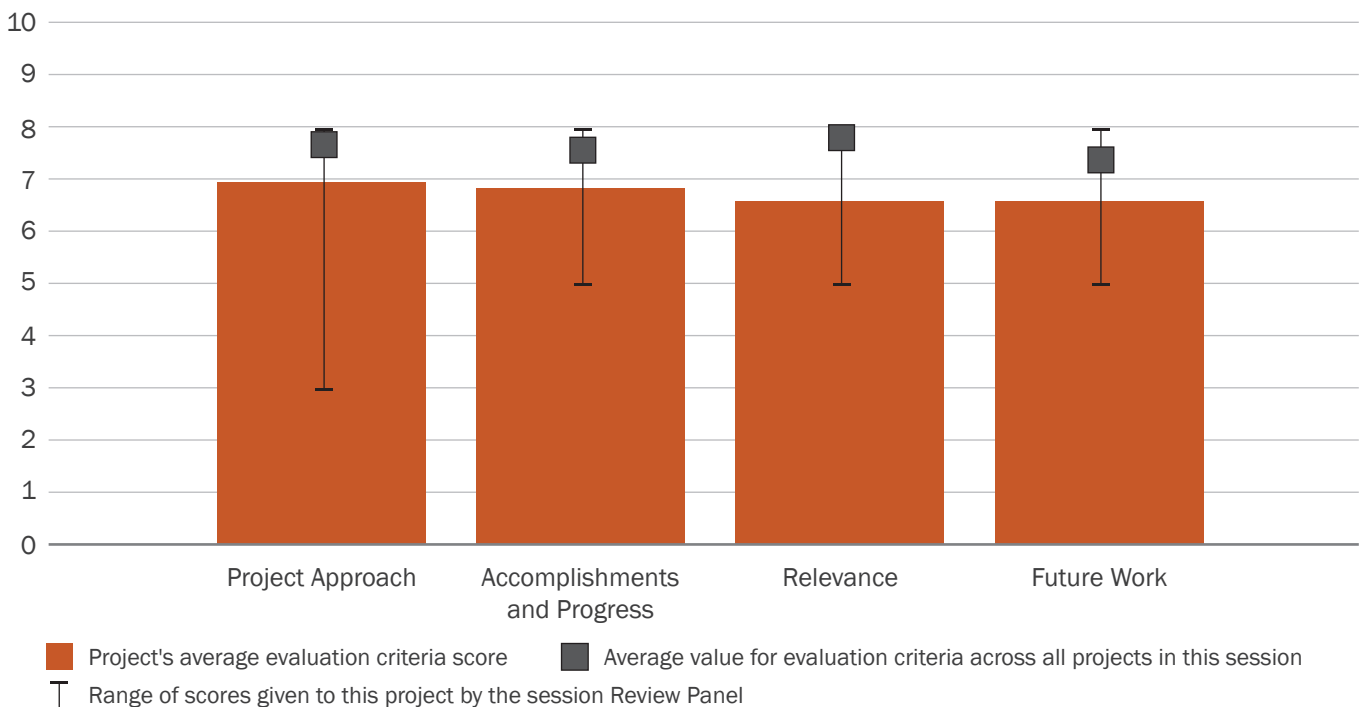

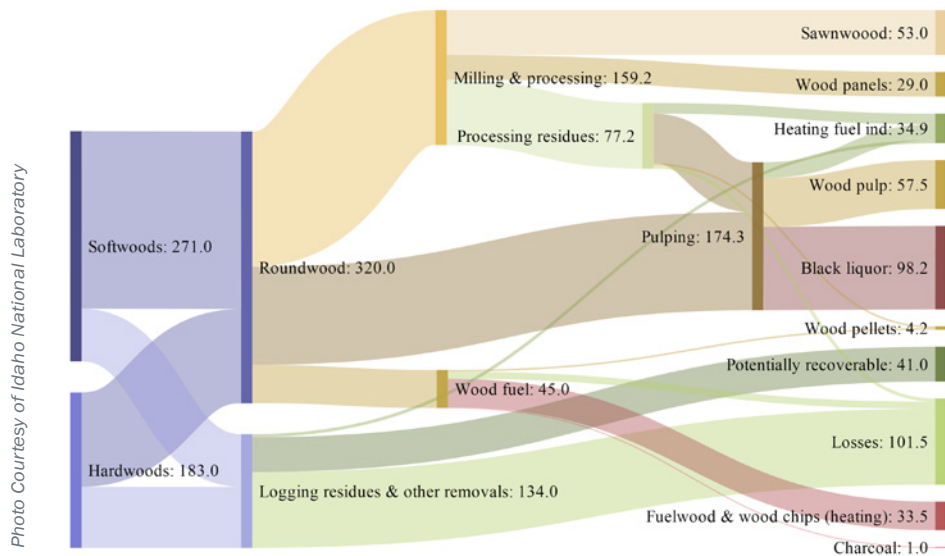

Overall Impressions

- My overall impression is one of confusion. I suggest in the future trying to use some concrete examples to explain approach and results. I learned more from the questions from reviewers when the presenter gave explicit examples than I did from the generalizations in the presentation.
- The project evaluates and provides information of a potential mature market. Its interesting work but of limited value.
- Strength: The potential domestic application of pellets into markets other than combustion.

Weakness: The project needs to vertically integrate supply chain to market, and bring in other partners.

- There are lots of insights and informative results presented here. All future work focuses on developing models with more detail or additional model assumptions. It seems more relevant for future work to focus on additional herbaceous feedstocks and alternative markets.
- This project seems to meet an internal BETO need, and as such provides value. As an exercise to identify methods for minimizing risk in the developing biofuels industry, it can provide insight to possible

directions of market development. Alternative markets for biomass feedstocks need to be examined more closely. Feedstocks grown for biomass have been selected for high productivity rather than palatability or nutrient content, and are likely not to be considered a high-quality animal feed. The project should consider near-/mid-term needs and the impact of vertical integration on the biomass market.

- Overall, the project has tried to identify issues related to market penetration of biomass products in the international market and solve issues raised from non-technical factors. However, the project should clearly state how the outcome of this project will directly impact BETO's goals and objectives.

PI Response to Reviewer Comments

- This project directly supports the BETO MYPP Milestone: "by 2017, determine the impact of competing uses and policy and market demands (e.g., biopower or pellet exports) on feedstock supply and price projections." It also indirectly supports BETO goals such as meeting a \$84/dry ton cost target at the reactor throat by identifying pathways for biomass mobilization that leverage existing and emerging non-biofuel markets to spread investment costs (e.g., of preprocessing facilities such

as a pelleting depots) across multiple markets and products and as such helps reduce intermediate unit production costs. Identifying non-biofuel feedstock markets for growers and processors to sell into (and determining their price, volume, and time span) creates near-term commercialization strategies in the biomass market. This directly supports the BETO goal of mobilizing domestic resource to fuel a U.S. bioeconomy.

The project does not explicitly model a mature market. Rather it is focused on analyzing current biomass supply chain and market structures to lay out pathways for additional resource mobilization, which could support the nascent bioeconomy. As such, the project aims at providing transition strategies via meta-level market analysis. It is not aimed at solving technical issues of emerging integrated biorefinery operations. Rather, it is a means to

supplement respective process solutions by market analysis on their scale-up and deployment potential.

Within the given budget only the most-promising biomass industries for near-term commercialization and feedstock supply have been investigated in detail. Across the last 2 years, this was foremost the U.S. wood pellet industry.

Future work aims at determining potential spill-over and learning curve effects from this industry to other markets, herbaceous biomass in particular. Also, the project will expand its supply chain analyses to include strategies and lessons learned from other industries (e.g., vertical and/or industrial integration). Less focus will be given to the development of new modeling capabilities. Rather, the next steps will be to integrate and connect this work to other modeling and analysis approaches across the FSL and Analysis and Sustainability Programs.

FEEDSTOCK SUPPLY MODELING

(WBS#: 1.2.3.1)

Project Description

Simulation analyses of this project identify regional supply chain strategies to reliably and cost-effectively deliver consistent feedstocks for production of competitive biofuels and bioproducts using highly variable biomass resources. The Integrated Biomass Supply Analysis and Logistics Model, Supply Characterization Model, and advanced visualization tools have been integrated with biomass availability projections from the 1.1.1.1 Resource Assessment Project to (1) determine progress toward BETO feedstock cost and quantity targets, (2) model impacts of quality-improvement strategies along the supply chain, (3) estimate equipment and infrastructure needed for supplying biomass feedstocks, and (4) identify promising candidate feedstock blends for experimental testing.

Recipient:	Oak Ridge National Laboratory
Principal Investigator:	Erin Webb
Project Dates:	10/1/2005-9/30/2018
Project Category:	Ongoing
Project Type:	Annual Operating Plan
DOE Funding FY 2014:	\$300,000
DOE Funding FY 2015:	\$1,050,000
DOE Funding FY 2016:	\$1,050,000
DOE Funding FY 2017:	\$950,000

Applying simulation tools across the supply chain can help develop strategies to avoid the system inefficiencies that can occur when component technologies are blindly selected without consideration of how they impact or are affected by other supply chain design decisions. Accomplishments in this project include the following: development of an algae biomass supply chain model, new analysis of corn stover field drying potential across the United States, and expanding the Billion-Ton projections to include cost delivered to the reactor throat.

Weighted Project Score: 8.0

Weighting: For ongoing projects, there is equal weighting across all four evaluation criteria: Approach, Relevance, Accomplishments and Progress, and Future Work.

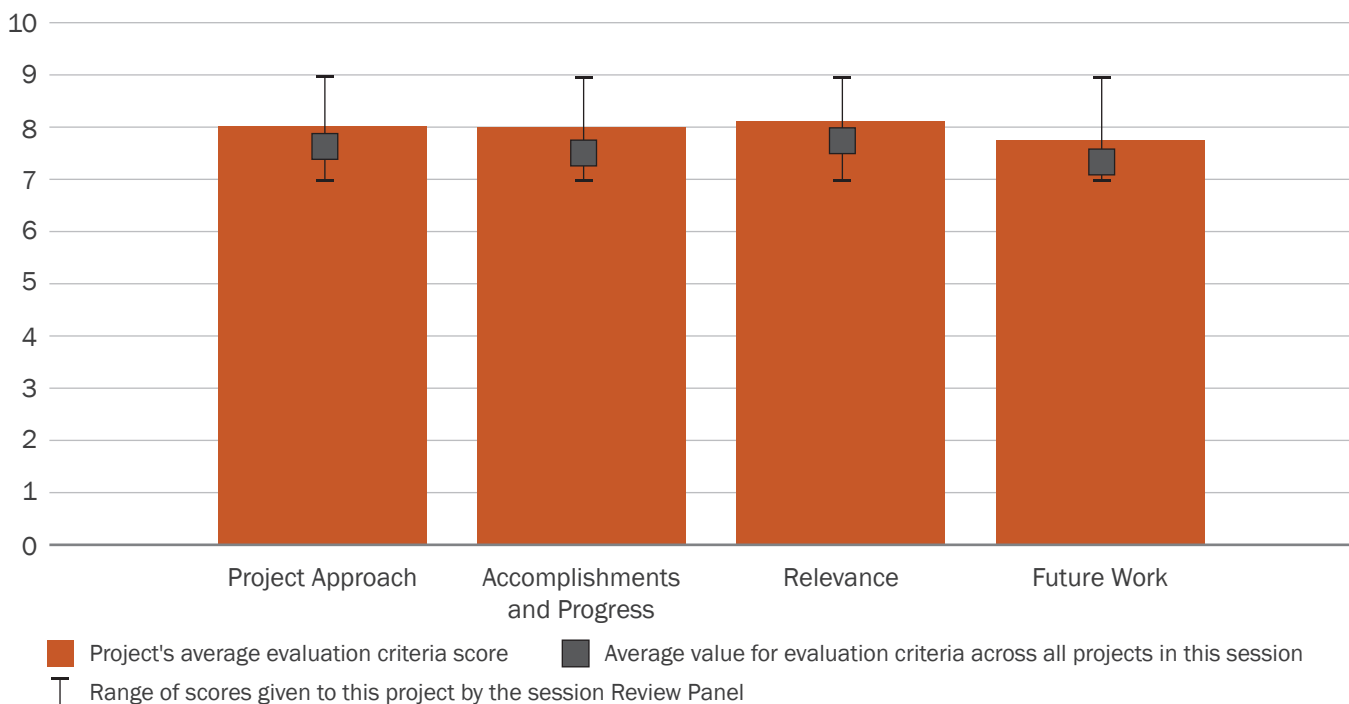

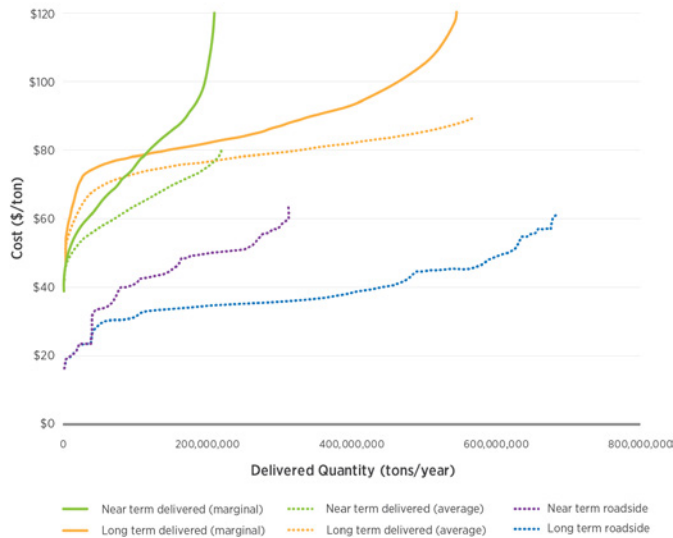

Overall Impressions

- This is a high-impact, high-quality project that provides useful, realistic information on feedstock supply. It is well-integrated with commercial and sustainability aspects of the BETO portfolio.
- This is excellent work to estimate the potential and growth of the industry.
- This project has presented useful research. However, there needs to be integration with agencies, universities, and industry. The project needs to validate simulations with real data. The project should put more emphasis on the near term (e.g., the next 5 years) and less on the long term (e.g., 15–20 years).
- This project has accomplished a lot with its integrated modeling work; however, these studies seem disjointed and it is not clear if data are available to validate these complex processes.
- This project utilizes best available information from BETO and other biomass logistics projects to conduct a systems analysis of the supply chains and associated biorefineries. These efforts are closely linked to and support the *BT16* estimations of

biomass availability. Technical accomplishments include the prediction of available biomass quantities at varying costs and the resulting number of biorefineries. The assumptions made are obviously overly optimistic, as a projection of 73 biorefineries in 2017 was shown, when we actually have two. Methodologies to benchmark and adjust predictions with current conditions should be considered.

The work presented and the future activities effectively utilize expertise in the national laboratories, particularly Oak Ridge National Laboratory and INL. The planned work on modeling of biomass moisture management should be closely aligned with the efforts at INL to consider the storage and processing of high moisture materials. This project makes valuable contributions to BETO.

- Overall, the project has developed and integrated field drying modeling into the FSL model to manage and monitor the moisture content of delivered feedstock. It is expected that the future work will include additional feedstock quality specifications explicit to a biorefinery for accurately estimating the feedstock cost, while minimizing the feedstock quality risks.

PI Response to Reviewer Comments

- In the last 2 years, the Oak Ridge National Laboratory logistics modeling team have been working with their industrial partners to collect field data such as equipment speed, fuel consumption, bale bulk density, and harvest moisture content, etc. These models currently have updated input data. New harvest data were collected from biomass producers, aggregators, and equipment manufacturers (i.e., local farmers, State University of New York harvest team in New York and Oregon, Antares, Pacific Ag, and AGCO Corporation).

DESIGN AND DEMONSTRATION OF AN ADVANCED AGRICULTURAL FEEDSTOCK SUPPLY SYSTEM FOR LIGNOCELLULOSIC BIOENERGY PRODUCTION

(WBS#: 1.2.3.101)

Project Description

This nearly-completed 3-year project developed and demonstrated four innovative, first-of-their-kind pieces of equipment that are aimed at significantly reducing the cost of delivered herbaceous biomass. This equipment included a Self-Propelled Baler (SPB), a Bale Picking Truck (BPT), a Self-Loading Trailer (SLT), and a Heavy Crop Header for harvesting high-yielding energy crops. This equipment was designed and fabricated during the first 2 years of the project and demonstrated on available crops (corn stover, wheat straw, and warm season grasses) across the nation, as available.

Recipient:	FDC Enterprises Inc. (FDCE)
Principal Investigator:	Fred D. Circle
Project Dates:	9/1/2010–6/30/2015
Project Category:	Sun-setting
Project Type:	FY 2009–Feedstock Logistics: DE-FOA-0000060
Total DOE Funding:	\$4,991,934
Project Dates:	2007-2014

Operational performance and cost data were collected and analyzed throughout the project to measure the costs of baseline harvesting (using conventional harvesting equipment) and advanced harvesting with the newly developed equipment. These data revealed that the project met its original goal of developing equipment that is realistically capable of reducing the cost of delivered biomass by \$13 per dry ton. Each machine was tested after fabrication and put to the test in one or more commercial harvesting seasons. During these tests, operational flaws were found and fixed through upgrades and improvements. The first new SPB, BPT,

Weighted Project Score: 9.2

Weighting: Approach–25%; Relevance–25%; Accomplishments and Progress–50%.

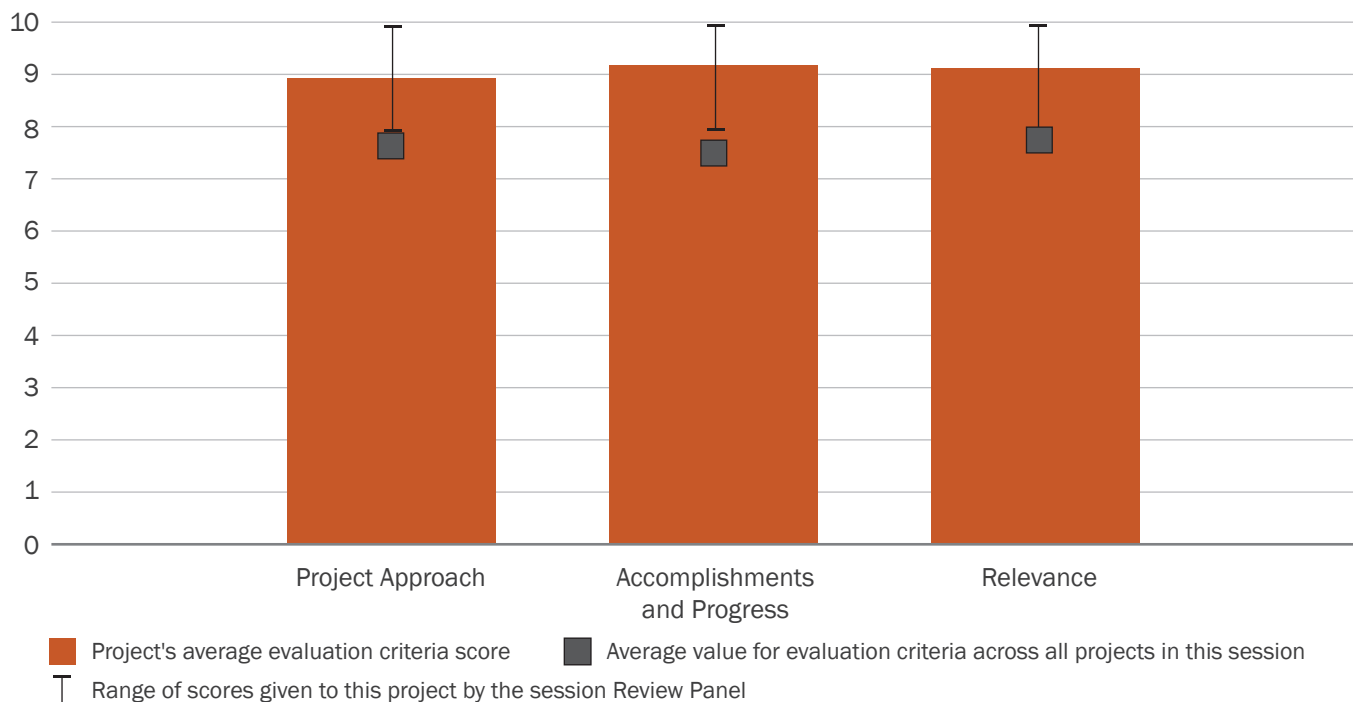

and two new SLTs were ready for use during the 2013 harvest season. Since then, over 40 SLTs have been ordered and are currently under fabrication. All of the equipment will be commercially available to the industry as demand increases.

Overall Impressions

- This was a very useful project that provided enabling experience, data, and equipment designs for the biomass industry, thus reducing commercial supply chain risk.
- This was an excellent project that provided a significant amount of industrial relevant data for the development and validation of industrial collection, harvesting, storage, and transport systems.
- This shows great improvements in bale transportation (e.g., more efficient and fast delivery, and direct feed into feed line). However, efforts in improving equipment for the efficient transportation of energy crops (e.g., sorghum or energy cane) are also needed. Separation of seed heads from stalks in the case of sorghum. Impact of harvesting equipment on biomass quality (e.g., ash or trash content) is needed. Overall, great project and execution.
- This project successfully developed and tested four new machines in 3 years that reduce cost by \$13/dry ton. Well done.
- This was a report of the FY 2009 High Tonnage projects by FDCE. This project must be viewed as a major success. Each of the proposed machines was developed, and evaluations have occurred over 15,000+ acres, providing confidence in the reported results. The results to date have been reduced cost to deliver biomass, innovation in the development of new machines that reduce cost/increase capacity, and commercialization of some of those machines in related industries. The Integrated Biomass Supply Analysis and Logistics Model modeled cost for the

full system showed a significant cost reduction, which was the primary goal of the project. This completed project provided significant innovation and directly addressed BETO goals.

- Overall, this project has accomplished all major challenges associated with collection, harvesting, storage, and transport of biomass bales using an integrated approach. The design innovation on the mobile floor trucking system is a major significant improvement to facilitate back-hauling capabilities.

PI Response to Reviewer Comments

- To the greatest extent possible, our team will continue our efforts to test and demonstrate the equipment innovations, where applicable, in crops other than corn stover. Our team has access to a 600-acre farm of high-yielding switchgrass and we will test as many pieces of equipment as possible as part of our annual harvest operations on that farm and elsewhere. We will also include biomass quality measurements as part of those efforts this will be much more affordable and practical now that we have developed the NIR bale probe that facilitates accurate and rapid measurement of key bale quality parameters.
- While one of our primary overall project objectives is to demonstrate innovative means of minimizing feedstock supply costs, our project team has been most focused on defining measurable technical goals and then measuring our performance against those goals for each piece of equipment our team members have developed and tested. Several performance targets were presented in the review presentation: (1) developing a self-unloading truck that can unload a full load of bales in less than 5 minutes; (2) developing a windrow merger that is capable of collecting two windrows of corn stover or perennial grass in a single pass through the field; (3) developing a bale gathering machine that can gather a full

truckload of bales (36) in each trip to the field; (4) increasing round bale density by more than 10%; 5) increasing round baler field efficiency by more than 50%; (6) developing a bale accumulator that can stack and drop six square bales at a time at each drop location in the field; (7) developing a square bale de-stacking machine that can reliably de-stack a 2 wide x 3 high stack of bales into a single line of bales for feeding a grinding line; (8) developing an automated round bale infeed line that can automatically remove net wrap and de-bale round bales for feeding into a grinding line; (9) developing a round bale hauling and unloading system that enables rapid high-volume unloading of round bales (20 bales in less than 10 minutes, including automated unloading onto a grinding line; and (10) developing a field-deployable NIR bale probe that can accurately and rapidly measure moisture, ash, glucan, and xylan content in biomass bales.

- Our team has gone to great lengths to document and measure all performance targets and other factors that will impact operational costs and functional value of each innovation our team members are developing. We have built an extensive database of harvest performance data, including results from harvest operations on over 30,000 acres of herbaceous biomass. This database includes labor, fuel, supplies, and maintenance costs for each harvested field. This and other performance data and results are periodically shared with DOE national laboratories (e.g., Oak Ridge National Laboratory and INL) for independent analysis and reporting. A similar approach has been and will (in future testing) be utilized for all process-related testing (bale handling, conveying, grinding, etc.) our team conducts. These results have and will include (wherever possible) efficiency improvements, productivity improvements, labor requirement reductions, fuel reductions, electricity reductions, cost impacts, and biomass quality measurements, etc.

DEMONSTRATION OF AN ADVANCED SUPPLY CHAIN FOR LOWER COST, HIGHER QUALITY BIOMASS FEEDSTOCK DELIVERY

(WBS#: 1.2.3.106)

Project Description

This project will demonstrate an advanced biomass supply chain for high-impact, high-quality feedstocks from the field to the throat of a biorefinery. In doing so, the project will address nearly all of the technical barriers by BETO’s FSL Program. The project builds on the earlier innovations of team members to reduce feedstock costs. This work highlights key gaps throughout the supply chain where biomass harvesting and processing costs could be further decreased while maintaining the end user’s feedstock quality specifications. This effort includes designing and deploying new systems for end-use processing (e.g., new milling equipment, advanced

Recipient:	FDC Enterprises
Principal Investigator:	Fred Circle
Project Dates:	9/15/2013–9/30/2017
Project Category:	Sun-setting
Project Type:	FY 2013–Advanced Biomass Feedstock Logistics Systems II (Logistics II): DE-FOA-0000836
Total DOE Funding:	\$5,250,000
Project Dates:	2006-2017

bale handling, NIR monitoring and sampling, etc.), further refining feedstock production equipment developed and demonstrated under prior efforts and testing by this and other project teams, and demonstrating new feedstock harvest and logistics equipment. Importantly, this includes development of equipment and processes to provide biorefiners and harvesters the flexibility to produce and use round and/or square bales more efficiently and cost-effectively than is possible using today’s “off the shelf” conventional equipment. To date, the

Weighted Project Score: 6.8

Weighting: Approach–25%; Relevance–25%; Accomplishments and Progress–50%.

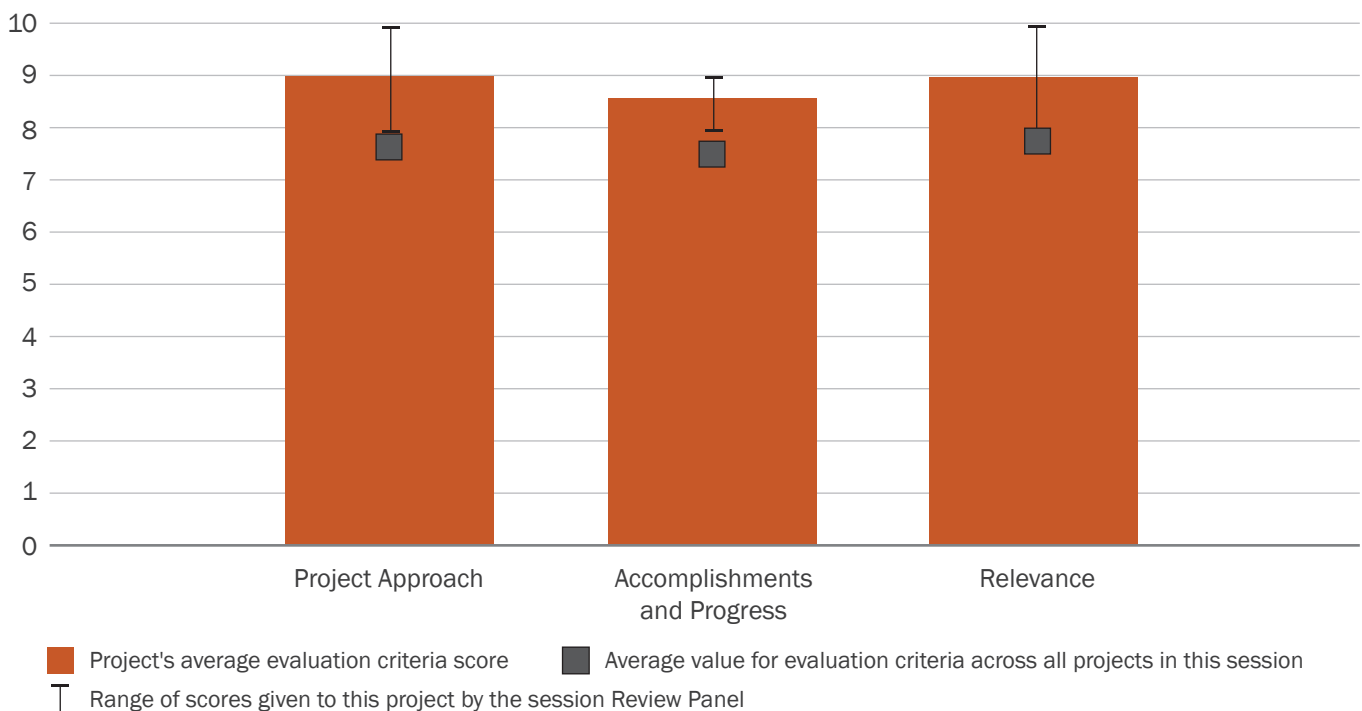

project has designed, fabricated, and tested many new equipment innovations, conducted commercial-scale biomass harvest demonstrations, tested new methods for analyzing biomass feedstocks with NIR, and assessed soil sustainability impacts.

Overall Impressions

- This is an important project for developing the equipment, analytical techniques, and workforce for the biomass industry. Project results have been rapid and impactful to industry partners.
- This project is well on its way to meeting the needs of the industry in the near to mid-term to lower the cost of the collection, harvesting, storage, and transport supply system. The team has a very good understanding of the needs of the industry and the systems required to lower the biomass supply cost.
- Great presentation, met all objectives mentioned, resulted in the development/improvement of equipment (prototypes) that will improve biomass quality, reduce harvesting cost. I would like to see the same approach on other feedstocks (energy crops).
- The team did a good job identifying and filling gaps in equipment supply chain to reduce cost.
- This was a report of the FY 2013 high tonnage projects by FDCE. The team of industrial partners from FY 2009 was successful enough that additional partners asked to join the FY 2013 project with no funding, a clear sign of impact for the project. The inclusion of an optimized system that would accommodate round bales, used in the smaller farm operations of the eastern states, is an expansion of the original project concept and potentially expands the portions of the United States where biofuels industries might be sited.

Suggestions for enhancing the value of this project during the remaining years include emphasizing the operation over a larger range of biomass crops (the

great majority to date has been corn stover), and the incorporation of delivered biomass quality into the evaluations of the systems. The FY 2013 funding did require quality assessment, and the NIR work reported does address that aspect. However, the project is urged to include those quality measurements into their assessments of the system performance.

- Overall, the project is directed right on the target and made considerable progresses to find solutions to technical barriers on handling round and square bales. A number of innovative technologies were developed in an attempt to successfully handle bales. The performance and cost targets will hopefully be addressed in order to meet the commercial viability and success of the project.

PI Response to Reviewer Comments

- Similar to the “Design and Demonstration of an Advanced Agricultural Feedstock Supply System for Lignocellulosic Bioenergy Production” project, our team will continue our efforts to test and demonstrate the equipment innovations, where applicable, in crops other than corn stover. Our team has access to a 600-acre farm of high-yielding switchgrass and we will test as many pieces of equipment as possible as part of our annual harvest operations on that farm and elsewhere. We will also include biomass quality measurements as part of those efforts--this will be much more affordable and practical now that we have developed the NIR bale probe that facilitates accurate and rapid measurement of key bale quality parameters.

While one of our primary overall project objectives is to demonstrate innovative means of minimizing feedstock supply costs, our project team has been most focused on defining measurable technical goals and then measuring our performance against those goals for each piece of equipment our team members have developed and tested.

Several performance targets were presented in the review presentation, including the following: (1) developing a self-unloading truck that can unload a full load of bales in less than 5 minutes; (2) developing a windrow merger that is capable of collecting two windrows of corn stover or perennial grass in a single pass through the field; (3) developing a bale gathering machine that can gather a full truckload of bales (36) in each trip to the field; (4) increasing round bale density by more than 10%; (5) increasing round baler field efficiency by more than 50%; (6) developing a bale accumulator that can stack and drop six square bales at a time at each drop location in the field; (7) developing a square bale de-stacking machine that can reliably de-stack a 2 wide x 3 high stack of bales into a single line of bales for feeding a grinding line; (8) developing an automated round bale infeed line that can automatically remove net wrap and de-bale round bales for feeding into a grinding line; (9) developing a round bale hauling and unloading system that enables rapid high-volume unloading of round bales (20 bales in less than 10 minutes, including automated unloading onto a grinding line); and (10) developing a field-deploy-

able NIR bale probe that can accurately and rapidly measure moisture, ash, glucan, and xylan content in biomass bales.

Our team has gone to great lengths to document and measure all performance targets and other factors that will impact operational costs and functional value of each innovation our team members are developing. We have built an extensive database of harvest performance data, including results from harvest operations on over 30,000 acres of herbaceous biomass. This database includes labor, fuel, supplies, and maintenance costs for each harvested field. This and other performance data and results are periodically shared with DOE national labs (Oak Ridge National Laboratory and INL) for independent analysis and reporting. A similar approach has been and will (in future testing) be utilized for all process-related testing (bale handling, conveying, grinding, etc.) our team conducts. These results have and will include (wherever possible) efficiency improvements, productivity improvements, labor requirement reductions, fuel reductions, electricity reductions, cost impacts, biomass quality measurements, etc.

NEXT GENERATION LOGISTICS SYSTEMS FOR DELIVERING OPTIMAL BIOMASS FEEDSTOCKS TO BIOREFINING INDUSTRIES IN THE SOUTHEASTERN U.S.

(WBS#: 1.2.3.107)

Project Description

The diverse portfolio of biomass sources that is available in the Southeast United States, including a vast supply of pine “residue,” creates a valuable strategic position for the region. To realize this opportunity, new systems are required that can utilize biomass with different characteristics to consistently produce a feedstock that meets process specifications. An alternative system for whole tree transport to a state-of-the-art merchandising depot will broaden access to pine biomass from current forest industry operation, minimizing in-woods contamination and lowering overall cost. This biomass

Recipient:	University of Tennessee
Principal Investigator:	Tim Rials
Project Dates:	2/1/2016–1/31/2019
Project Category:	Ongoing
Project Type:	FY 2013—Advanced Biomass Feedstock Logistics Systems II (Logistics II): DE-FOA-0000836
Total DOE Funding:	\$4,000,000
Project Dates:	2009-2017

source will be available to formulate feedstock to meet process specifications by blending with energy crops, like switchgrass and poplar. Implementing this vision requires new information on the chemical composition and the chemical changes that are induced during the multiple preprocessing steps (e.g., size reduction, moisture removal, and densification). Online sensors based on NIR spectroscopy are under development to monitor important properties of the biomass (i.e., carbon, ash, and moisture content). The newly available bio-

Weighted Project Score: 7.0

Weighting: For ongoing projects, there is equal weighting across all four evaluation criteria: Approach, Relevance, Accomplishments and Progress, and Future Work.

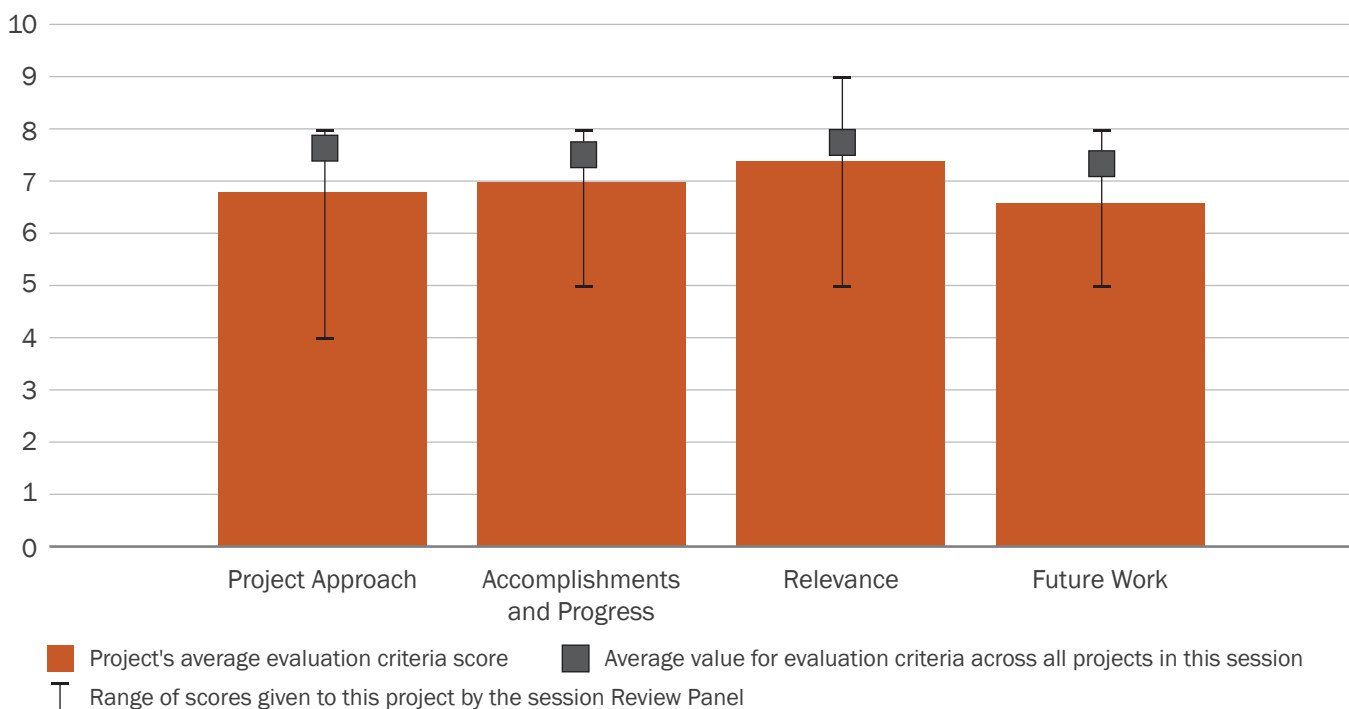

mass quality data will be incorporated into a statistical process control platform, allowing cost saving through process efficiency gains and enabling improved quality and consistency through blending. This capability will ultimately reduce operational risks from supply chain disruptions, while allowing larger-scale biorefineries to be constructed and operated.

Overall Impressions

- This is an important project to assess the feasibility of biomass depots to enable low-cost, high-quality, and abundant feedstock.
- The project is relevant to increase the quality and reduce the cost of the biomass for thermochemical conversion systems.
- The project is on track. However, the different rheological, physical, and chemical properties of the various biomass materials due to blending can be a challenge during pretreatment, enzymatic hydrolysis.
- There is a lot of future work planned but the go/no-go milestones and metrics for success are unclear.
- This project builds on earlier high tonnage projects, and is still early in the funding period. It focuses on the development of a mixed feedstock supply system based on pelleting woody and herbaceous materials together into a consistent product. The project team is large and includes partners with appropriate expertise to meet the project tasks. The plan for high-moisture pelleting leverages other ongoing FSL activities at INL.

With 33% of the project period past, progress toward the tasks seems to be on schedule. The full tree log trailer has been designed, fabricated, and testing is underway. While the design is apparently successful in increasing the payload, the need for The U.S. Department of Transportation to change highway regulations to allow the use of the trailer

raises questions about the industrial viability of that design. A central part of Task 1 is the merchandizing of pine trees at a forest depot.

From the presentation, it was difficult to identify the progress on that activity. The NIR quality evaluation of Task 2 is well underway, and the NIR models presented achieved high R^2 values. There should be significant synergy with other NIR biomass quality projects funded by BETO, but that was not discussed. Tasks 3 and 4 will be initiated in the near future.

Certain aspects of the project were addressed during the presentation, and are likely to impact the ultimate success. The project is based on an assumption of producing a mixed feedstock pellet that would be used in thermochemical (pyrolysis) conversion. The preliminary modeling of the conversion as impacted by varying carbon, ash, and moisture demonstrated significant change in the output, but no material was presented as to the acceptable limits for economic viability. Mixing wood and switchgrass to produce the pellets combines processes with biomass harvested year-round and over a short season. The influence of the dynamics of these collection systems did not seem to be included. The project appears to have individual partners conducting the portions that they are responsible for, but it is not clear how the parts will come together to provide a system evaluation.

- Overall, the project has some potential on achieving certain technical barriers. Hopefully, the team will consider addressing key technical barriers quantified to developing advanced supply logistics system and documenting critical performance measures and cost reduction approaches. The project has some opportunities to focus the directions at the interface of feedstock quality and conversion pathway requirement.

PI Response to Reviewer Comments

- The concept of a blended biomass feedstock is not unique to this work. INL has provided detailed analysis of several blended biomass feedstock designed to meet cost and quality targets. We are following this same approach but are actually demonstrating the performance on many of the specific unit operations and the performance of the biomass blends in biorefinery processes. Wood and switchgrass allow for a unique and complimentary supply chain for biomass crops. Wood can be harvested year-round, though weather can dictate access to the woods and regularity of availability. Switchgrass is optimally harvested in the winter, when the plant is dormant, allowing for collection of a biorefinery feedstock that is low in moisture and relatively low in ash, but then requires storage for a year-round supply. Blending the two into a single, consistent feedstock offers synergies in improving operational efficiencies, and reducing risk in the supply chain. Although we are only addressing pine and switchgrass in this project, it is likely that other biomass types could, and would, be incorporated into commercial practice.
- It is true that combining switchgrass and pine feedstocks will have a series of implications on the cost of the final biomass derived hydrocarbon fuel that can be grouped into three categories, as follows:
 - Costs and quality of the raw biomass delivered to the depot
 - Costs and quality of the blended feedstock delivered to the throat of the pyrolysis reactor
 - Cost of the final biomass derived hydrocarbon fuel produced from the blended biomass.

There are tasks in the project that will inform this integrated analysis.

As the Panel noted, the costs of the pine will depend on the effectiveness of the new transportation system. The portion of the whole tree mass allocated to the biorefinery, and the composition and moisture content of this pine fraction will also be important and demonstrated in this work. The composition and costs of switchgrass are reasonably well-established, and the low moisture content will balance the negative impacts of the higher ash content. The costs of creating consistent blends will also be demonstrated in this work. The consistent quality will have to compensate for the increased costs of blending and pelletizing this material. The value of blending these two feedstocks will be evaluated with experimental data generated by the team, and with engineering process models and financial models. The environmental life cycle impacts will also be tracked based on the field and demonstration data, and the process models. These benefits must be greater than the added costs of producing the blended feedstock.

In most cases, the economics will be based on the nth plant. As stated by Dutta et al., the nth plant and its economics assumes that several plants using the same technology have already been built and are operating. This assumes that a successful industry has been established with many operating plants. Because the techno-economic model is a tool used primarily for (1) studying new process technologies or (2) comparing integrated schemes in order to comment on their relative economic impact, it is prudent to ignore artificial inflation of project costs associated with risk financing, longer startups, equipment overdesign, and other costs associated with pioneer plants. According to this report by Dutta et al., these costs “overshadow the real economic impact of advances in conversion science or process engineering research.” At the very least, nth-plant economics should help to provide justification and support for early technology adopters and pioneer plants about longer term prospects.

⁹ Abhijit Dutta, Asad Sahir, Eric Tan, David Humbird, Lesley J. Snowden-Swan, Pimphan Meyer, Jeff Ross, et al., *Process Design and Economics for the Conversion of Lignocellulosic Biomass to Hydrocarbon Fuels: Thermochemical Research Pathways with In Situ and Ex Situ Upgrading of Fast Pyrolysis Vapors* (Golden, CO: National Renewable Energy Laboratory, 2015), NREL/TP-5100-62455, <https://www.nrel.gov/docs/fy15osti/62455.pdf>.

IMPROVED ADVANCED LOGISTICS UTILIZING WOODY AND OTHER FEEDSTOCKS IN THE NORTHEAST AND PACIFIC NORTHWEST

(WBS#: 1.2.3.108)

Project Description

The goal of this project is to lower the delivered cost of hybrid poplar and willow woody crops to \$84/dry ton by optimizing and demonstrating a supply system while maintaining the quality of the biomass. The project is divided into five task areas: (1) harvest and logistics, (2) transport and storage, (3) preprocessing, (4) feedstock characterization, and (5) logistic and economic modeling. As an iterative process that involves data collection from commercial harvests of woody crops, provision of these data to modeling teams who then suggest improvements for the next field season based on results from model runs. Improvements in the operation of a single pass cut and chip harvesting system

Recipient:	The Research Foundation of State University of New York (SUNY)/SUNY College of Environmental Science and Forestry
Principal Investigator:	Tim Volk
Project Dates:	4/1/2016–3/31/2019
Project Category:	Ongoing
Project Type:	FY 2013–Advanced Biomass Feedstock Logistics Systems II (Logistics II): DE-FOA-0000836
Total DOE Funding:	\$3,000,000

and in the optimization of the chip collection, handling, storage, and preprocessing systems will be implemented and tested. Additional objectives include overcoming technical hurdles to develop coordinated and optimized harvesting, transport, storage and delivery logistics so that feedstock of consistent quality and quantity can be delivered year-round. Preprocessing techniques including drying and densification with INL’s PDU and hot

Weighted Project Score: 7.7

Weighting: For ongoing projects, there is equal weighting across all four evaluation criteria: Approach, Relevance, Accomplishments and Progress, and Future Work.

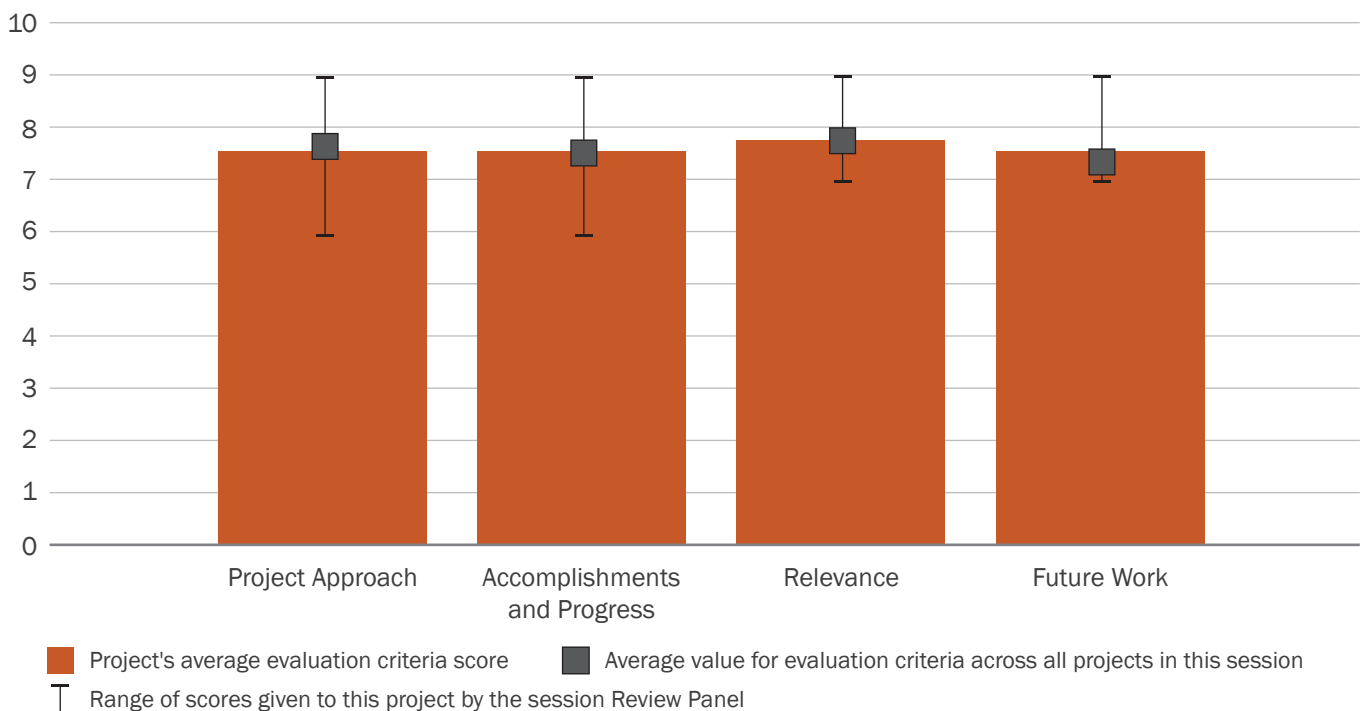



water extraction techniques will be tested to reduce variability of feedstock characteristics that are important to end-users. Rapid biomass quality assessment techniques based on NIR technology will be developed so that the quality of the feedstock can be assessed throughout the supply chain.

Overall Impressions

- Overall, this is a straightforward project that leverages other investments (Sun Grant) and commercial activities to reduce the cost of woody biomass.
- The project seems to lack innovation and is in the early stages of implementation.
- NIR data on woody biomass have been done by other agencies such as NIFA coordinated agricultural projects. USDA/DOE integration is recommended.
- This project is well-designed and addresses the entire woody supply chain in a logical and integrated fashion.
- This is a well-organized project that builds on the results of the earlier high tonnage biomass logistics project awarded to the same group. It is directly

addressing BETO goals. Appropriate progress has been made relative to the project timeline. No major weaknesses were identified for this project, although there was concern over the size of piles used in evaluating storage systems for the chopped material. Small piles with high surface to volume ratio (as shown in the presentation) likely will not provide the same storage results as industrial sized piles with smaller surface/volume ratios. NIR quality assessment should be coordinated with the work in multiple other BETO projects to maximize the value and accuracy of the quality data.

- Overall, the project has some potential to improve the supply logistics system and assessing the feedstock quality. It would be highly helpful if the project could break down the general barriers into specific technical barriers related to feedstock or end-user needs.

PI Response to Reviewer Comments

- We are working with two of the other BETO-supported harvesting and logistics projects to share ideas, knowledge, and develop NIR models collaboratively that will be as robust as possible. We have also been able to draw on some previous, preliminary work that has been done on willow at the SUNY College of Environmental Science and Forestry, Cornell, and GreenWood Resources as part of previous projects. GreenWood Resources will develop an NIR model to characterize non-commercial sections of hybrid poplar trees grown for solid-wood products. This includes the evaluation and incorporation of knowledge and models developed during the Sun Grant partnership (Project Title: Hybrid Poplars as a Regional Ethanol Feedstock: Its Development, Production and Economics).

The concerns about piles and NIR assessments are addressed in previous comments.

BIOMASS FEEDSTOCK NATIONAL USER FACILITY

(WBS#: 1.2.3.3)

Project Description

Biomass handling and feedstock preprocessing challenges have resulted in long startup time and low throughput of pioneer-integrated biorefineries. Challenges include the following: (1) an inability to quickly and accurately detect variation in properties of raw biomass delivered to the biorefinery, specifically the moisture and inorganic content, and (2) an inability to reliably process biomass with varied properties into feedstock that consistently meets conversion specifications.

BFNUF advances the BETO goal of growing a bio-economy by engaging with industry in the scale-up of biomass preprocessing systems and by developing robust biomass preprocessing technologies to overcome

Recipient:	Idaho National Laboratory
Principal Investigator:	Quang Nguyen
Project Dates:	7/3/2008–9/30/2018
Project Category:	Ongoing
Project Type:	Annual Operating Plan
DOE Funding FY 2014:	\$2,000,000
DOE Funding FY 2015:	\$2,130,000
DOE Funding FY 2016:	\$1,700,000
DOE Funding FY 2017:	\$1,700,000

variability and feed handling challenges. The project is designed to address these variability and handling challenges with an adaptive control system integrated into BFNUF’s PDU, a full-size feedstock preprocessing system. Sensors detect variability in the biomass and intelligent algorithms, incorporating PDU data as the basis for control system development, and adjust PDU equipment to compensate. Preliminary results show that the adaptive control logic improves the operability and throughput of two-stage grinding of high-moisture corn stover bales.

Weighted Project Score: 7.9

Weighting: For ongoing projects, there is equal weighting across all four evaluation criteria: Approach, Relevance, Accomplishments and Progress, and Future Work.

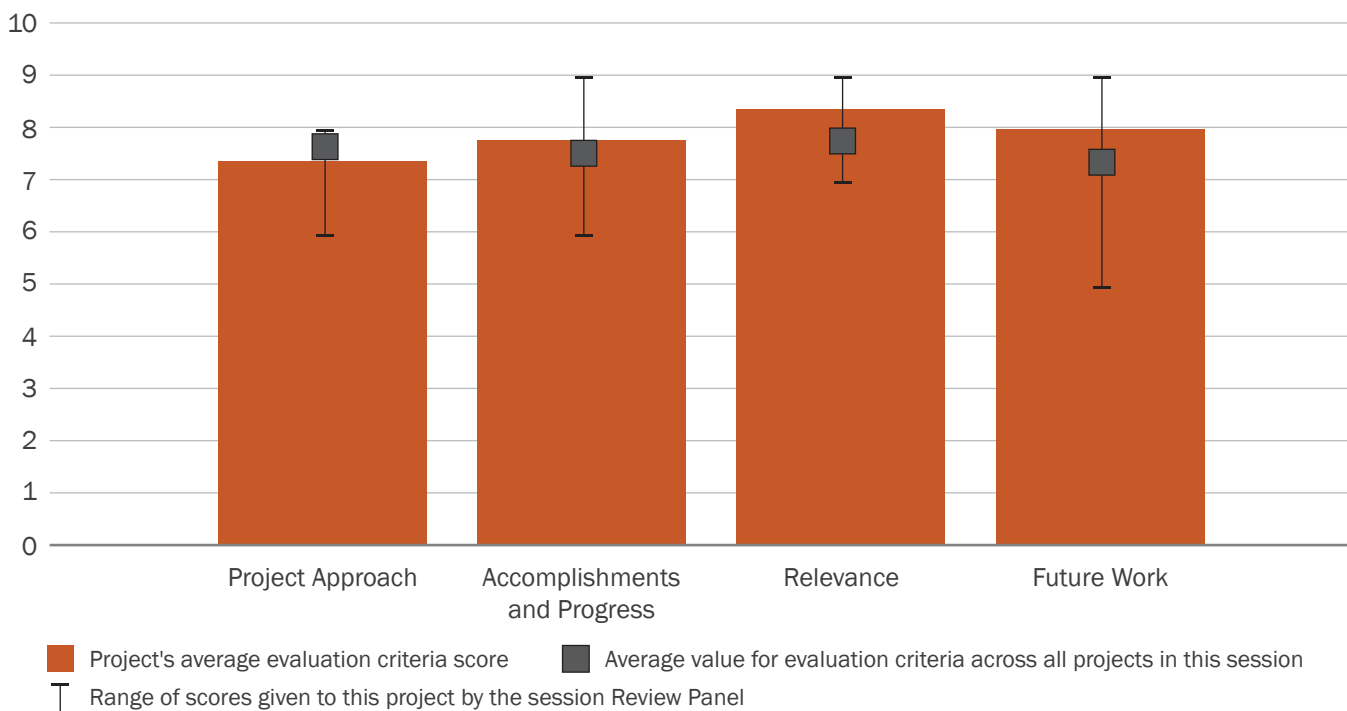



Overall Impressions

- BFNUF provides a valuable and unique asset to the FSL program. The ability to examine either individual unit operations in a feedstock supply chain or, ideally, the entire system of processing and conveying unit operations provides a necessary capability for supporting the development of a commercial scale biofuels industry. The development of the adaptive control grinding system clearly demonstrated the ability of the facility and the related personnel to address critical problems. Mention of the 1984 Rand Corporation report¹⁰ on the difficulties faced on startup by facilities handling bulk biomass materials was particularly pertinent, and provides a justification for research into methods to minimize the bulk handling/processing challenges. While BFNUF has demonstrated value, there remain several concerns about its ability to maximize success. Some of these are structural in the organization of and expectations for the unit.

The unit has been asked to be self-supporting. Funding can come from industrial users who pay 100% of costs for their tests, or from non-proprietary projects, which are charged only 50% of the costs. Most

of those reduced rate projects are BETO projects. At the same time, the unit is expected to do R&D projects such as the grinder control system. Since the review team was told that the number of full cost industrial projects has been limited, the managers of the facility should determine if this was due to a lack of demand, competition from original equipment manufacturer test laboratories or limitations such as concern over control of intellectual property rights. There is a fundamental conflict between an expectation that the BFNUF be self-supporting and also conduct research on enhanced operations. The necessary high levels of full-charged industrial project needed to reach the self-supporting goal are very likely to limit the achievement of BETO-focused research projects.

The unit is advised to concentrate efforts in two areas: (1) fundamental understanding of the limitations of unit operations over a wide range of biomass conditions (e.g., species, moisture ash, etc.), and (2) system performance throughout an entire preprocessing operation set. Enhancing the fundamental knowledge of unit operations as a function of the biomass properties will provide significant value, both to the second effort on overall system performance, and to the need to identify a quality basis for pricing biomass. This, of course, ties into the efforts to develop sensors that can rapidly assess quality parameters.

This project must be a central part of the FCIC portfolio.

- Overall, the project has established a series of PDUs that could be used for bioenergy industries to minimize feedstock risks and validate or optimize conditions suitable for commercial success. It is anticipated that the project team will identify barriers and develop strategies for increased use of this facility.

¹⁰ Edward W. Merrow, *Linking R&D to Problems Experienced in Solids Processing* (Santa Monica, CA: RAND Corporation, 1984), <https://www.rand.org/pubs/papers/P7034.html>. This paper is also available in print form.

PI Response to Reviewer Comments

- There are several challenges to reaching BFNUF’s goal of becoming self-sustaining, including the following:
 - BETO-sponsored projects take highest priority, and yet do not fully utilize the User Facility capability all the time. Nevertheless, the User Facility must be fully staffed in order to support these projects.
 - The PDU tries to fill in the gap with external contract work, but these small projects do not often fit in the schedule, which lead to inefficient use of resources and limited contract work.

- The PDU’s limited capability and specialized equipment do not allow broadening services. The current cumbersome contractual procedures do not allow quick response to industrial requests for quick acceptance of new work.

We are trying to improve the capability of the PDU by requesting new funding from BETO. We are working toward streamlining contract agreements to better respond to requests from industry. We are partnering with two industrial leaders in biochemical and thermochemical conversion in submitting a proposal to DOE-BETO’s and the USDA National Institute of Food and Agriculture’s joint Integrated Biorefinery Optimization FOA to develop robust feedstock pre-processing and reactor feeding systems.

US-INDIA CONSORTIUM FOR DEVELOPMENT OF SUSTAINABLE ADVANCED LIGNOCELLULOSIC BIOFUELS SYSTEMS

(WBS#: 2.5.2.7)

Project Description

This project is a collaborative effort between institutions and companies in the United States and India that participate in the U.S.–India Joint Clean Energy Research & Development Center. It emphasizes sustainable feedstock cultivation and supply, biochemical conversion technologies for production of butanol, and analysis of sustainability and supply chain management. The specific objectives of the United States’ component of the project are to (1) genetically improve biomass-sorghum feedstocks to generate cultivars and hybrids adapted to flooding or drought, (2) use switchgrass research plots on commercial farms to identify soil and environmental criteria that will ensure commercially successful feedstock production on mar-

Recipient:	University of Florida
Principal Investigator:	Wilfred Vermerris
Project Dates:	9/18/2012–9/17/2017
Project Category:	Ongoing
Project Type:	Other
Total DOE Funding:	\$6,213,857
Project Dates:	2010-2015

ginal lands, (3) develop novel microbial biocatalysts for the production of butanol from switchgrass and sorghum biomass, and (4) develop products from biorefinery residues that minimize environmental impact and maximize revenues. Furthermore, a sustainability analysis is being conducted, which includes development of certification protocols and sustainability standards, assessment of energy requirements and emissions, and economic analyses as the basis for successful supply chain management. Successful completion of the project is expected to result in benefits the United States and India by delivering a validated commercial working model for feedstock production and supply, biochemical conversion and affiliated biorefinery technologies as part of an integrated sustainable supply chain.

Weighted Project Score: 5.1

Weighting: For ongoing projects, there is equal weighting across all four evaluation criteria: Approach, Relevance, Accomplishments and Progress, and Future Work.

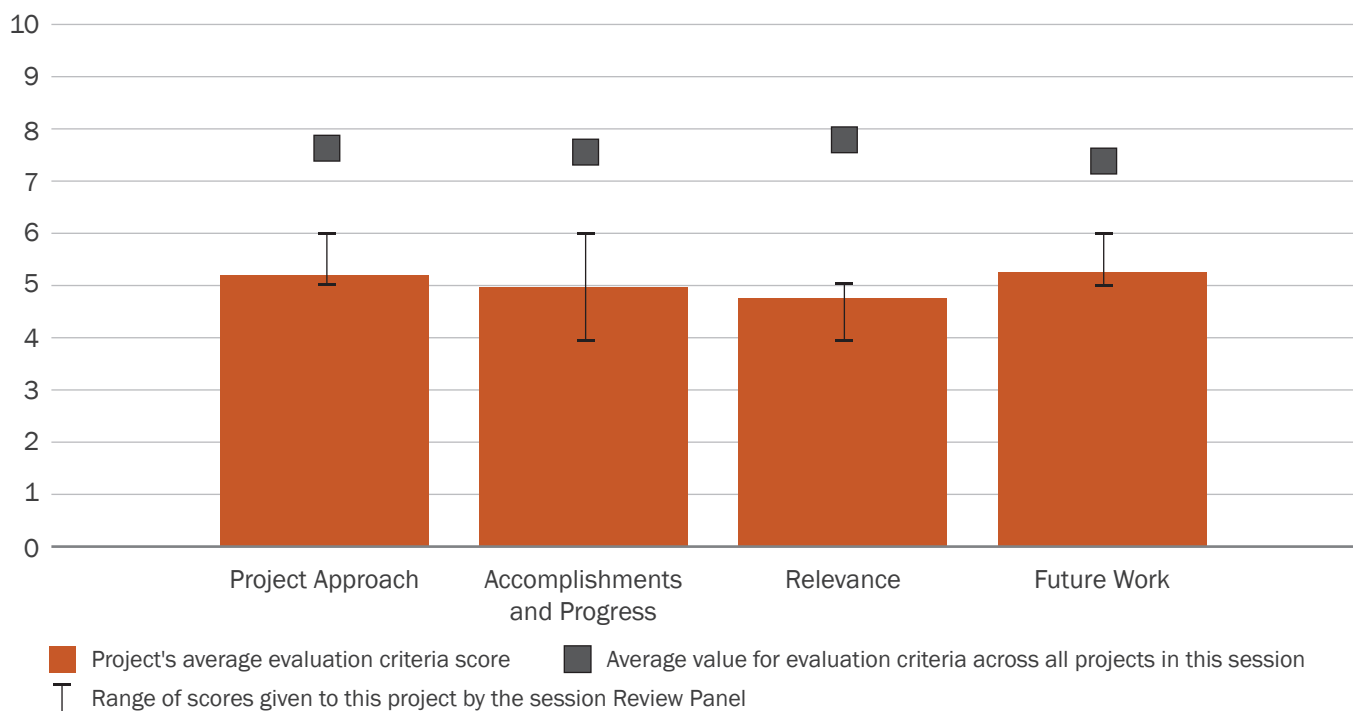

Overall Impressions

- Overall, this project provides some useful information for feedstock production (both breeding and agronomy), but must be more balanced and integrated to be useful. The conversion and life cycle analysis (LCA) aspects were not as compelling, but likely still useful.
- The value proposition needs to be established to justify the project; it has too many components diluting the efforts thus decreasing the value of the work.
- The project helps in the creation of academic capabilities and the training of the human resource for the deployment of the biorefinery industry.
- It is unclear if there is a use (if any) of generated waste streams. There is an overly optimistic goal of increasing butyrate yields from 45 g/L to 100 g/L by genetic modification. The presenter needed to clearly present project accomplishments and costs associated with byproducts.
- This project has many objectives that seem to have been poorly integrated, and accomplishments to date have been limited. The loss of industrial partners and the University of Florida biorefinery pilot plant have been complicating factors. Some progress was reported in identifying sorghum germplasm for flooding and sugarcane aphid (an addition to the project objectives) resistance. However, it is not clear what the potential for growing biomass in flood prone areas really is.

Regarding the production of butyrate, a significant improvement in the production rate (45 g/L) was reported, but the path to the goal of 100 g/L is unclear and perhaps overly optimistic. One of the project objectives is to demonstrate recovery and utilization of biorefinery and waste residues. Progress reported to date was limited to the design of an anaerobic digester for the stillage that would extract methane and possible fertilizer materials. Future work was stated as optimizing the use of biorefinery residues

for methane production and soil amendment, but the details provided were insufficient to give confidence that this objective will be achieved.

This project is a consortium with India, but no information was presented about synergies gained through that consortium. When questioned, the exchange of scientists was mentioned, but the planned exchange of breeding materials was not allowed. While this presentation rightly concentrated on the United States work funded by DOE, I would have expected a functional consortium to have generated enough scientific merit to have warranted mention.

Many of the comments from the 2015 reviewers still appear to be appropriate for the project in 2017. The progress in the last 2 years has not removed the concerns of those reviewers.

- Overall, the project has made moderate progress on the feedstock development and development of biocatalysts for improved production of butanol and ethanol from sorghum and switchgrass, respectively. The yield potentials and flood tolerance of developed varieties are yet to be determined to attract major bioenergy industries. The progress on the economic and environmental indicators for the specified pathways is still under developed.

PI Response to Reviewer Comments:

- On behalf of the project team, I would like to thank the review team for their time and comments. Responses to the recurring comments include the following:
 - Given the limited amount of time allocated for each project presentation, I chose to give a broad overview of the different activities, rather than a detailed report on a small selection. This meant leaving out many of the details. The statement of project objectives is updated annually, with detailed targets for all activities. Quarterly reports to DOE are used to determine progress towards these targets.

- In terms of the economic benefits, with several million acres of flood-prone land in the United States and over \$3 billion in crop losses each year due to flooding, having flooding-tolerant germplasm will reduce crop losses and associated loss in farm income. Crop improvement is a slow process, and it is only now (summer 2017) that we have advanced breeding material available for larger-scale trials that will generate yield data. This includes commercially promising high-biomass sorghum hybrids able to grow on poor soils, and a mapping population segregating for flooding tolerance that will enable us to measure the yield gains resulting from improved flooding tolerance.

The proposal's original focus on ethanol was changed due to DOE's focus on advanced bio-fuels, which led to butanol as the fuel of choice. Butanol is toxic to the microbes that produce it. Butyrate, on the other hand, is not, and can therefore be produced at high titer, and reduction of butyrate to butanol is straightforward. The two strategies for industrial production of microbial products are to (1) start with an organism that produces the target molecule but in low product yield or at high cost, or (2) start with an organism that is well-suited for industrial use (e.g., *Escherichia coli* [*E. coli*]) but that does not produce the target molecule. In the latter case, a new pathway needs to be introduced. We have pursued both strategies, maxing out at 45 g/L using the first strategy with *Clostridium thermobutyricum*, and aiming for 100 g/L with the second strategy in *E. coli*. This yield target is not unreasonable given industrial production of lactate and succinate. Multiple strategies for improvement of butyrate-producing *E. coli* are being pursued. Since

the presentation the butyrate titer has further increased from 18 to 25 g/L.

The progress on valorization of lignin-rich residues is, contrary to what is suggested in the review, not restricted to anaerobic digestion. In the presentation, I also showed enhanced plastics with enhanced ultra violet-tolerance. Additional efforts focus on antimicrobial films and use of biorefinery stillage as fertilizer.

- The economic and environmental components of the project are admittedly dependent on data generated by the crop management team and the Biomass Conversion team. This was also pointed out during the presentation. We now have those data in hand, which can be fed into the models that have been generated as part of the project. Some of those models were tested with data available from established production systems in the Midwest, and this is what led to the portfolio management strategy that was presented, and which is intended to mitigate shortages in the regional feedstock supply.

The project plan is updated annually, based on whether milestones set for the preceding year were met. Projects that did not meet their milestones have been discontinued. The current set of activities is more streamlined than at the start of the project, and further streamlining is expected.

In summary, at this point the groundwork has been laid to integrate the data from the different areas and to obtain robust production statistics for the improved crop germplasm, so that at the completion of the project the boundaries of what is and is not feasible will be defined.

WASTE TO WISDOM: UTILIZING FOREST RESIDUES FOR THE PRODUCTION OF BIOENERGY AND BIOBASED PRODUCTS

(WBS#: 3.4.1.4)

Project Description

Overcoming the barriers to utilizing low-value forest residues that are generated from forest management activities can be accomplished by employing biomass conversion technologies (BCTs). At present, the greatest obstacle to increasing utilization of these materials is the high cost of transportation. BCTs can convert comminuted forest residues into biochar, torrefied pellets, and briquettes; improve their market desirability; increase their value; and increase transportation efficiencies. This project aims to (1) develop system logistics that improve the economics, accessibility, and production

Recipient:	Humboldt State University
Principal Investigator:	Han-Sup Han
Project Dates:	9/30/2013–9/30/2016
Project Category:	Ongoing
Project Type:	FY 2012–BRDI (FY12): DE-FOA-0000657
Total DOE Funding:	\$5,881,974
Project Dates:	2010-2013

of high-quality feedstock; (2) evaluate and scale up standalone BCTs that are operated at or near the forest for their commercialization; and (3) perform economic analyses and LCAs to enhance sustainability of biomass utilization through improved knowledge on socio-economic and environmental benefits.

The Waste to Wisdom project has found that the commercialization of BCTs has the potential to improve the economics of forest management activities, improve forest health, reduce catastrophic wildfire, sequester carbon, and reduce GHG emissions. In addition, the project

Weighted Project Score: 6.0

Weighting: For ongoing projects, there is equal weighting across all four evaluation criteria: Approach, Relevance, Accomplishments and Progress, and Future Work.

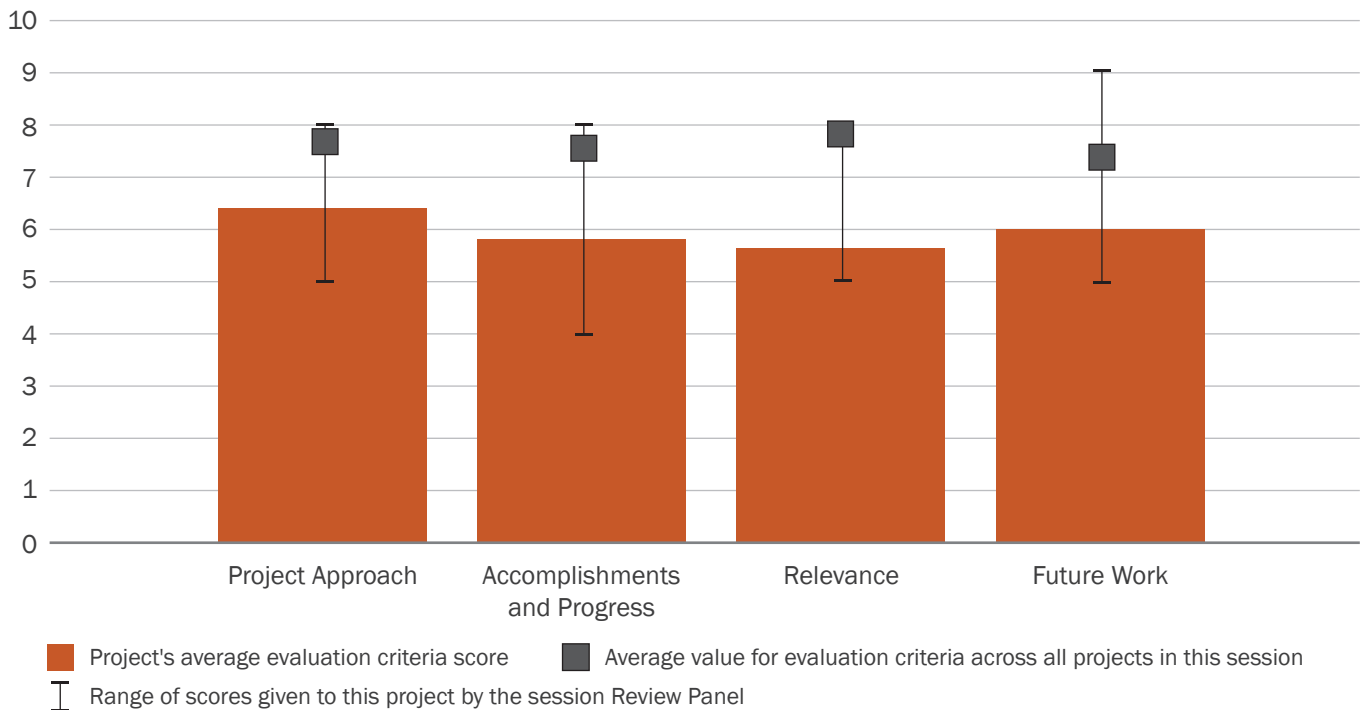



Photos Courtesy of Humboldt State University

may create employment in the forest and energy sectors, support economic development in rural areas, and effectively reduce our nation's dependence on fossil fuels by incorporating renewable fuels into current bioenergy and coal-fired energy facilities.

Overall Impressions

- This project does seem to support the forest products industry, but was not clearly relevant to BETO goals. Quality and impact of work over state of the art seemed minimal or not apparent.
- The project had created academic capabilities and provided for the training of students in the bioenergy opportunities.
- Biochar and torrefaction are not new. This project is similar to two Agriculture and Food Research Initiative coordinated agricultural projects funded in Washington. There has not been much output for

the length/duration of the project. There is a lack of cost assessments of pilot plant products. Objectives/goals overlap with other projects presented at the BETO Project Peer Review.

- The results of this project are not clear. One main result should be to determine which production pathway (biochar, torrefaction, or densification) is most logistically feasible, cost-effective, and sustainable.
- This project examined alternatives for converting West Coast forest residues into potential forms that could be utilized for biomass energy. The project has attempted to demonstrate biomass upgrading technologies at forest sites, and the project is nearing its completion. Biochar, torrefaction, and briquetting were all demonstrated.

The project intended to “...meet the price target (\$50–\$60/dry ton) with low ash contents (<1%),” but unfortunately, inadequate data were presented to compare results to these cost and quality targets. Data presented were generally subjective in nature, and when capacities of developed equipment were described, they were judged as successful when not meeting the target levels. After conducting the three demonstrations, the authors did not identify which of the alternatives would be most viable. While no complete analysis of the cost for delivered biomass in the form of biochar, torrefied, or briquetted material was provided, the costs reported for each machine operation provided in the extra pages seem to indicate that none of the examined systems could approach the BETO goal of \$84/demonstration and market transformation. The projections of potential jobs that might be created and the survey of public opinion about bioenergy were irrelevant to the focus of this project.

Although only a few months remain on this project, future work should concentrate on reporting on the feasibility of industrial scale operation of the examined systems and the likely delivered feedstock cost

for each system. The remaining \$1.6 million in the project should be focused on these efforts.

- Overall, the project has successfully addressed the integrated torrefaction and densification of woody biomass at a scale suitable to address technical feasibility of producing high-quality solid fuel. The project will hopefully address the issues related to converting forest residues into high-value solid biofuels along with targeted economic and environmental benefits.

PI Response to Reviewer Comments

- The Waste to Wisdom project management team can appreciate the reviewer's concern with the scope of the project and how it relates to BETO goals. We would like to reiterate that this research project was designed, proposed, and accepted as a Biomass R&D Initiative project and therefore the goals and

objectives are different from a normal DOE funding opportunity announcement. However, the goals of this project do align with several goals outlined in the 2016 BETO MYPP as mentioned in our relevance response.

- The management team would like to reassure you that we are following our proposed work scope and that we are on track to meeting all our project obligations. A significant delay in funding at the onset of the project forced a reorganization of the planned schedule. In addition, a switch in a major project partner created additional progress delays. These situations led to a request for a 1-year, no-cost extension. This extra time was necessary for us to complete important tasks and to move the project into the analysis phase. We anticipate finishing all project work tasks by the end of the fourth quarter of 2017.

CLEAN ENERGY MANUFACTURING ANALYSIS CENTER (CEMAC)

(WBS#: 6.3.0.8-10)

Project Description

CEMAC performs high-impact analysis, benchmarking, and assessment of supply chains and manufacturing for clean energy technologies that can be applied by decision makers to inform R&D, policy, and investment directions. Established in 2015, CEMAC is housed at the National Renewable Energy Laboratory and engages DOE, U.S. federal agencies, national laboratories, universities, and industry to promote economic growth and economic competitiveness. This collaborative project, which includes INL, National Renewable Energy Laboratory, and Oak Ridge National Laboratory, works to evaluate the manufacturing of agricultural equipment that would be necessary to meet the feedstock requirements for a large-scale biofuels industry. This work will outline the transitions needed between the existing conventional supply chains and the advanced logistics and designs necessary

Recipient:	National Renewable Energy Laboratory
Principal Investigator:	Maggie Mann, Quang Nguyen, Erin Webb
Project Dates:	10/1/2016-3/31/2018
Project Category:	New
Project Type:	Annual Operating Plan
DOE Funding FY 2014:	\$0
DOE Funding FY 2015:	\$0
DOE Funding FY 2016:	\$50,000
DOE Funding FY 2017:	\$350,000

to enable the large-scale deployment of biomass. The final product of this study will be a series of presentations and reports that outlines the forward-looking market drivers and barriers, the timelines required to bring equipment to market, and the costs associated with transitioning to these new systems. In addition, the study will work with industrial stakeholders to summarize business decisions regarding where to locate manufacturing facilities (in the United States or abroad) and to provide preliminary estimates on how biomass feedstock expansion could impact the U.S. economy.

Weighted Project Score: 7.2

Weighting: Approach–25%; Relevance–25%; Accomplishments and Progress–50%.

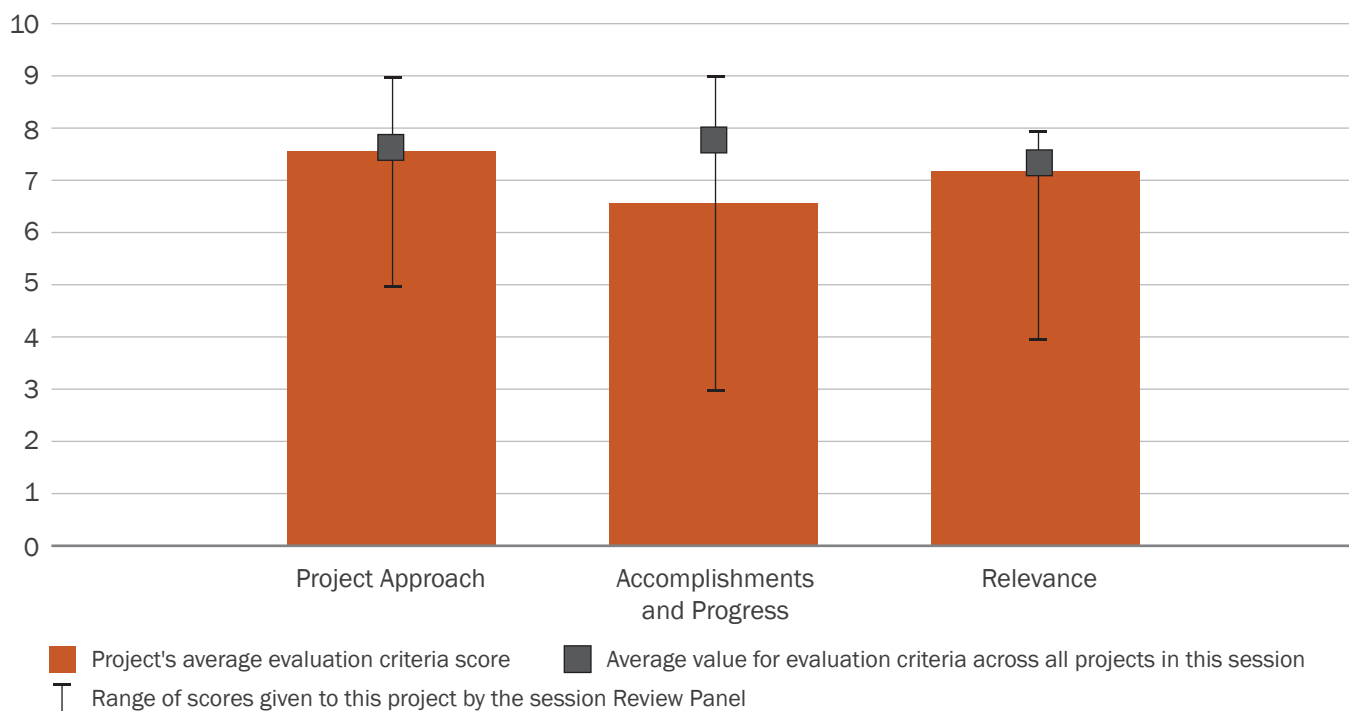

Overall Impressions

- This work complements the BETO portfolio by supporting the equipment industry needed to facilitate low-cost, high-quality, abundant biomass supply.
- This is a good effort to start planning for the growth of the industry in the long term.
- Valuable information will result from this work. I am glad to see collaboration with the various national laboratories, industry sector, and government agencies. Input of industry is crucial for the success of this project. I recommend that the project team validate existing models related to long-term trajectory.
- This work has value, but I don't think BETO should be leading this effort. It seems like there are many more pressing issues facing a billion-ton bioeconomy.
- This project focuses on the assessment of the market for equipment to support the biofuel industry. It represents the BETO contribution to the larger Clean Manufacturing Initiative of DOE. The result of this project has been the estimation of equipment and labor needs for the corn stover industry.¹¹ Future plans are to develop machinery needs for the advanced format feedstock system.

While the CEMAC engagement with original equipment manufacturers through American Society of Agricultural and Biological Engineers conferences is to be congratulated, this project represents a low priority activity for BETO. One of the lessons learned from interviewing equipment manufacturers is that the industry is responsive to the near-term market demands. Surveys of future market demand by a biofuels industry that is having difficulty growing are of little impact. The planned activities

require the projection of what logistics systems will be needed in the future, a problematic task at a time when active research is underway to identify those needs. This is a relatively small project that is entirely focused within the DOE-associated national laboratories. These funds could be better used at the laboratories to support the feedstock/conversion interface initiative.

- Overall, the project is focused on streamlining the FSL equipment and their feedstock specifications to meet biorefinery requirements. The project also has a potential to assess the socio-economic benefits of feedstock supply industries to a U.S. bioeconomy. Feedstock supply industries are key contributors to a bioeconomy along with bioconversion facilities (biorefinery).

PI Response to Reviewer Comments

- We thank the reviewers for their very helpful comments and suggestions. As we advance in this project, we will work to incorporate the feedback from the review team. Our overall objective in this CEMAC project is to understand the supply chains required for the agricultural equipment that will support the billion-ton bioeconomy and the potential impact that the growth of this industry can have on U.S. manufacturing and U.S. jobs. This project is looking far into the future to consider what equipment will be needed to enable this growth so that we can inform DOE, the stakeholder community, and the policy and decision makers to support U.S. economic growth. More specifically, we are working to understand how, as this field emerges, the United States can drive the creation of jobs and infrastructure to be a world leader in the manufacturing of agricultural equipment and support the needs of the bioeconomy.

¹¹ M. Ebadian, S. Sokhansanj, and E. Webb, "Estimating the Required Logistical Resources To Support the Development of a Sustainable Corn Stover Bioeconomy in the USA," *Biofuels, Bioproducts, and Biorefining* 11, no. 1 (2017): 129–149, doi:[10.1002/bbb.1736](https://doi.org/10.1002/bbb.1736).

To meet this goal, we must first understand what equipment might be required in these future scenarios and how it may vary from the equipment utilized to harvest and process conventional feedstocks in today's supply chain. The ongoing work supported by BETO has shown that conventional equipment will not meet the quality specifications required at the biorefinery gate and that modified equipment will be required to meet the quality and volume requirements. Therefore, this project builds on work led by Oak Ridge National Laboratory to consider these supply chains and from work led by INL to understand what is needed to meet the volumes and quality of feedstock in the future to support the needs of the bioenergy industry.

This project is working to fill an important need in the BETO portfolio by beginning to identify what potential gaps there are in U.S. manufacturing of agricultural equipment and how policymakers and funding agencies can help close those gaps in the near-term to support the growth of an emerging industry. This project seeks to develop and expand the metrics for BETO and biomass stakeholders to consider when investigating the biomass value chain, and provides a start to understanding the broader impact that the development of the bioindustry will have on the overall United States and global economy and how the United States can position itself to be a world leader in this field.

SDSU, SUN GRANT INITIATIVE, REGIONAL BIOMASS FEEDSTOCK DEVELOPMENT PARTNERSHIP

(WBS#: 7.1.2.1)

Project Description

The purpose of this program is to utilize a congressionally directed DOE project at South Dakota State University (SDSU) and the North Central Regional Sun Grant’s Competitive Grant program to address key issues and research gaps identified via the Sun Grant/DOE Regional Biomass Feedstock Partnership. SDSU agreed to employ the North Central Regional Sun Grant Center to administer a competitive grant program supporting the Regional Biomass Feedstock Partnership utilizing the Sun Grant’s authorization as a guide. Research that has been funded is germane to the sustainable production, harvest, transport and delivery of cost-competitive, domestically grown biomass. A total of 18 competitive

Recipient:	South Dakota State University
Principal Investigator:	Vance Owens
Project Dates:	7/30/2008–9/30/2016
Project Category:	Sun-setting
Project Type:	Congressional District Program
Total DOE Funding:	\$10,492,000

projects were funded in 11 states. Nine internal projects were awarded as well as six proof of concept projects. These 33 projects have covered a diverse array of topics.

Overall Impressions

- The project advanced collection, harvesting, storage, and transport systems and quantified the benefits of energy farms.
- Overall objectives/technical approach/ accomplishments were not clearly stated. Collaboration with other national laboratories would have been a plus.

Weighted Project Score: 7.0

Weighting: Approach–25%; Relevance–25%; Accomplishments and Progress–50%.

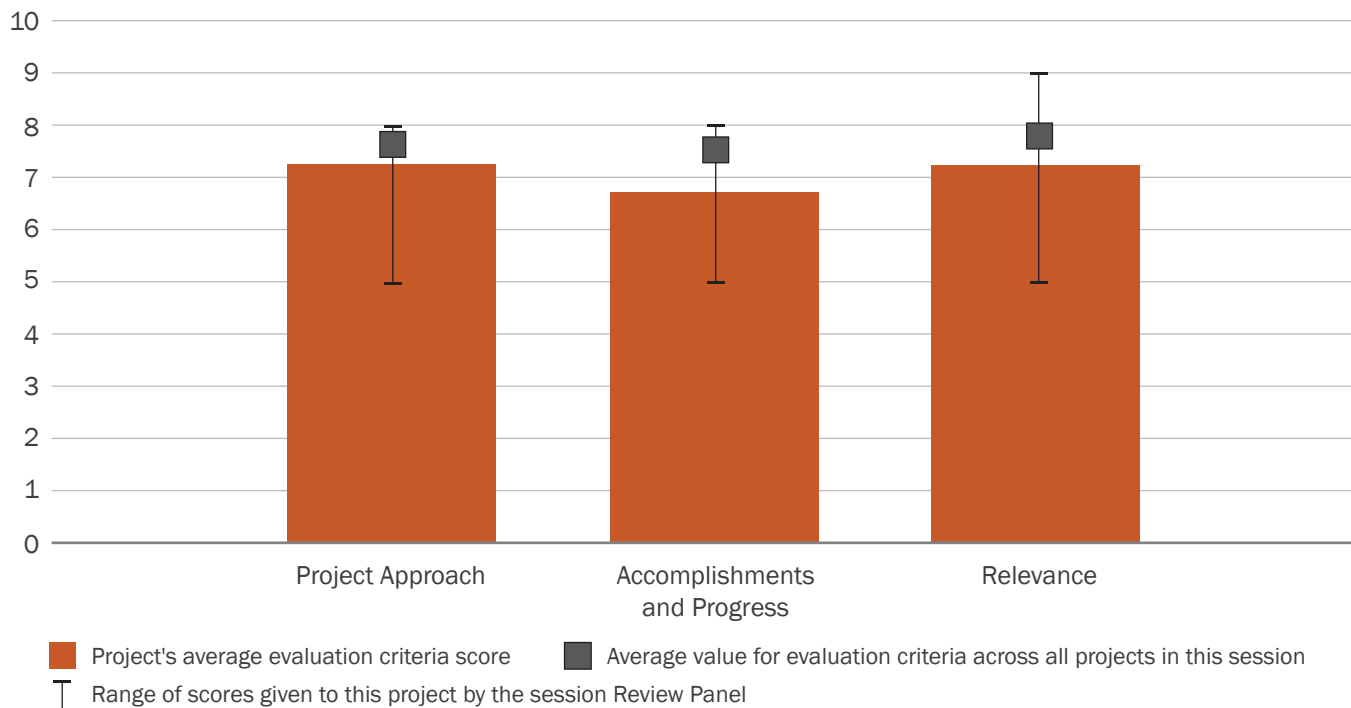

Photo Courtesy of
South Dakota State University



- Two activities of this completed project were reported. The Prairie Eco-Farm development examined the potential for a farming enterprise that would focus on grasses as the primary source of income provided value in documenting the income levels that could be achieved. However, the fact that the farm largely returned to row crop production when the project funding ended also demonstrated the limitations of that approach.

The second project addressed improvement of the corn stover supply chain in support of a biorefinery. This project provided significant value in terms of improving the productivity of the stover collection,

storage, and delivery system. It benefited from synergies with the BETO-funded high tonnage logistics systems that overlapped it in time. This project clearly aligned with and contributed to BETO's mission and goals.

- Overall, the project has accomplished some regional success related to biomass development and FSL systems. The technical successes are too diverse and may be further integrated to assess the overall success relevant to bioenergy industries.

PI Response to Reviewer Comments

- This project, through numerous sub-awarded projects across the nation, supported the DOE goal of producing a sustainable, cost-competitive supply of biomass feedstock. It was probably a little unconventional simply because it utilized these congressionally directed funds through the existing Sun Grant Initiative to identify and fund research projects relevant to the sustainable production, harvest, transport, and delivery of cost-competitive, domestically grown biomass.

RESEARCH, EXTENSION, AND EDUCATIONAL PROGRAMS ON BIOBASED ENERGY TECHNOLOGIES AND PRODUCTS

(WBS#: 7.1.2.2)

Project Description

The purpose of this program is to help develop more accurate feedstock cost supply information and improved communication with partners in the biomass feedstock supply chain. To accomplish this, replicated field trials were established across regions to determine the impact of residue removal on future grain yield and to develop energy crops within geographical regions. Further, a regional assessment of feedstock resources has been completed to determine feedstock supply curves. Field trials of corn, switchgrass, miscanthus, sorghum, energy cane, Conservation Reserve Program land, poplar, and willow were initiated in 2008, with some sites coming

Recipient:	North-Central Regional Sun Grant Center, South Dakota State University
Principal Investigator:	Vance Owens
Project Dates:	8/1/2005-12/31/2016
Project Category:	Sun-setting
Project Type:	HQ-Directed
Total DOE Funding:	\$20,619,986
Project Dates:	2010-2013

online one or 2 years later and some sites being planted before 2008.

Corn and sorghum final work were reported at the 2013 Peer Review and Conservation Reserve Program and sorghum were reported in the 2015 Peer Review; therefore, they will not be reported in this review. Data collected in this project are highly relevant to industry as biorefineries are sited and to policymakers as they evaluate bioenergy practices. These data have been uploaded to the KDF for use by the public, a key for making informed decisions regarding future bioenergy

Weighted Project Score: 8.3

Weighting: Approach-25%; Relevance-25%; Accomplishments and Progress-50%.

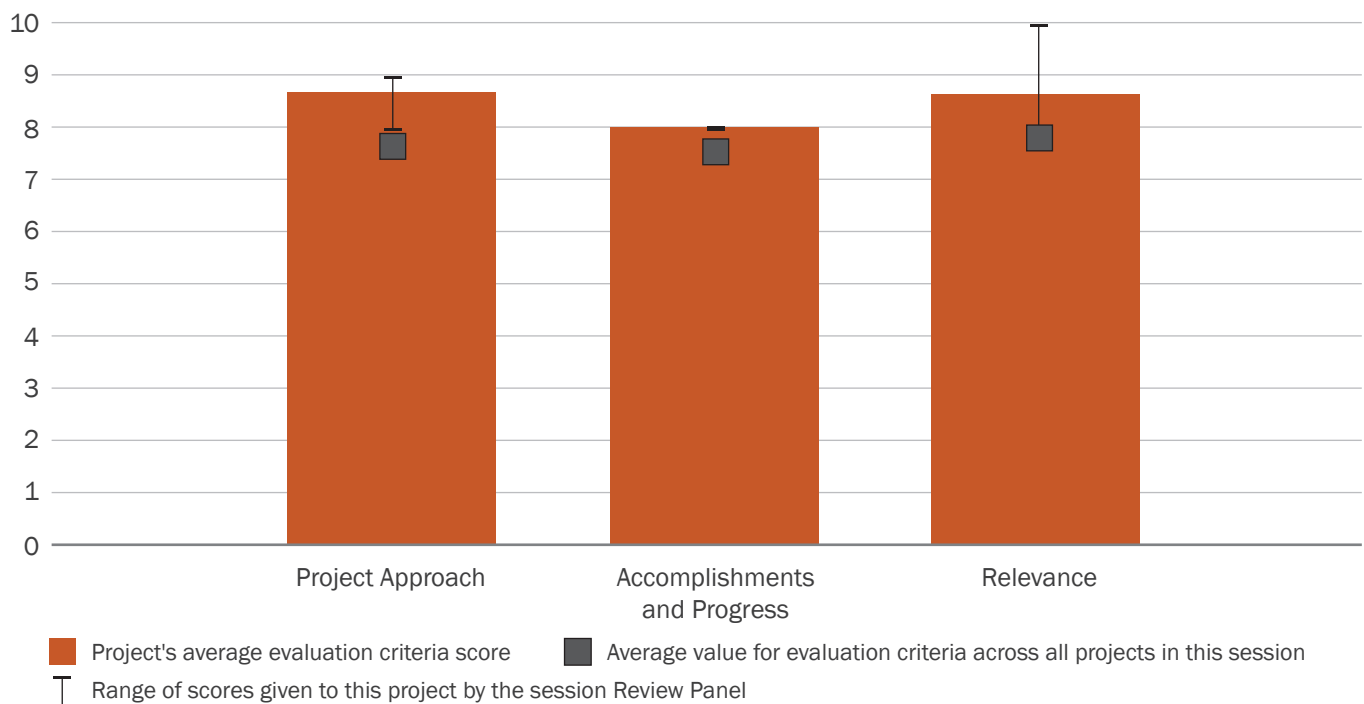



projects. Numerous scientific publications (including two special journal issues) and presentations, book chapters, websites, and reports (including a final summary report) have been produced from these efforts. In addition, BioWeb is an important outreach component of this research.

Overall Impressions

- Overall a comprehensive multi-year program to establish the feasibility of energy crops. The woody crop efforts are more mature and commercially relevant to deployment and commercialization of the crops. The herbaceous crops (miscanthus, energy cane, and switchgrass) provide relevant results to continue the development for the deployment and commercialization of the technology. The PI and the scientific collaborators should identify the gaps and propose recommendations for future research.

The mapping methods and analysis is an excellent reconciliation of available data, experimental results, expert judgment and use of relevant validated models for mature crops.

- The Sun Grant project significantly strengthens the role of energy biomass (herbaceous and woody biomass) potential in the U.S. bioenergy portfolio. The project has provided a fundamental underpinning of

BETO's analyses of the potential biofuels industry. Significant advances in improving herbaceous and woody biomass production resulted.

This project was necessary, and the data provided are extremely useful. Those data are limited however. The range of study sites was limited, and the study protocols did not include important information. Just as the Feedstock-Conversion Interface Consortium has been recognized as an area needed to be addressed, the interface between the energy crop and the logistics system that will harvest and deliver it also must be well-understood. Nitrogen and carbon balances for energy crops require further investigation.

The PIs of this project should be charged with conducting an assessment of the knowledge gaps that remain for their various feedstock crops. While a second round of study is not anticipated at this time, one of the needed outputs is that identification of research that remains to be done.

- Overall, the project has aimed to develop new energy crops, both herbaceous and woody crops, across the nation using regional sun grant partnerships. The project has developed a portfolio of biomass crops suitable for each region and disseminated the project outcomes through education and extension media.

The project also has a multidisciplinary team of scientists, researchers, educators, and policy analysts to focus on the critical issue of national energy security and local or regional economic development.

PI Response to Reviewer Comments

- We also feel that this has been an important project both in length and breadth. The opportunity to maintain field trials, particularly of perennial species, for up to 7 years is highly infrequent. As always, there are always questions that remain and further

research that is needed, not only on the species evaluated in the Regional Feedstock Partnership, but also on other species that were not studied. Some of these research gaps (e.g., lack of data for some species on the periphery of where they would be recommended) were identified through the in-person meetings between modelers and field trial PIs. In addition, some of this was addressed in the summary report that was developed in 2016. Part of the final technical report, currently being written, addresses some aspects of “where do go from here” as well.





FEEDSTOCK-CONVERSION INTERFACE CONSORTIUM



TECHNOLOGY AREA

CONTENTS

INTRODUCTION	78
FSL OVERVIEW	78
FSL REVIEW PANEL.....	80
TECHNOLOGY AREA SCORE RESULTS.....	81
FCIC REVIEW PANEL SUMMARY REPORT	82
FCIC PROGRAMMATIC RESPONSE	83
MULTI-SCALE PHYSICAL AND STRUCTURAL PARTICLE MECHANICS.....	85
ADVANCED FEEDSTOCK PREPROCESSING	88
BIOMASS FEEDSTOCK LIBRARY	91
FEEDSTOCK-PROCESS INTERFACE AND BIOCHEM BLENDED FEEDSTOCK DEVELOPMENT.....	94
DEVELOPMENT AND PROCESS INTENSIFICATION OF IONIC LIQUID-BASED LIGNOCELLULOSIC CONVERSION PROCESS.....	97
MIXED FEEDSTOCK CONVERSION SCREENING TO DEVELOP AND SCALE EFFICIENT INTEGRATED PROCESSING THROUGH PRODUCT TRANSFORMATION	100
FEEDSTOCK INTERFACE.....	103
FEEDSTOCK CHARACTERIZATION, PERFORMANCE, AND DEVELOPMENT	106
PRETREATMENT AND PROCESS HYDROLYSIS—PRETREATMENT	109

INTRODUCTION

Six external experts from industry and academia reviewed 14 projects (9 presentations) during the Feedstock-Conversion Interface Consortium (FCIC) portion of the 2017 Bioenergy Technologies Office (BETO or the Office) Peer Review.

Since FCIC is still in the planning stages (it is expected to be fully integrated and functional in fiscal year [FY] 2018), this review addressed existing feedstock conversion efforts. FCIC accounts for a total U.S. Department of Energy (DOE) investment value of approximately \$35,062,470, which represents approximately 5% of BETO's portfolio reviewed during the 2017 Peer Review. During the Project Peer Review meeting, the principal investigator (PI) for each project was given between 15 and 60 minutes to deliver a presentation and respond to questions from the Review Panel. Timeslots

were assigned based on each project's funding level and relative importance to achieving BETO goals.

The Review Panel evaluated and scored projects based on Peer Review evaluation criteria (approach, technical progress and accomplishments from FY 2015–FY 2017, relevance to BETO goals, and future plans). This section of the report contains the results of the project review, including full scoring information for each project, summary comments from each reviewer, and public responses from PIs. This section also includes an overview of FCIC, full scoring results and analyses, the Review Panel's summary report, and BETO's programmatic response.

BETO designated Dr. Steven Thomas as the FCIC Technology Area Review Lead. In this capacity, Dr. Thomas was responsible for all aspects of review planning and implementation.

FSL OVERVIEW

Many of the serious bottlenecks in the nascent bioenergy industry are centered on feedstock handling and preprocessing operations and on introducing feedstocks into the conversion process. These issues all occur where the feedstock supply system couples with the conversion process, referred to as the feedstock-conversion interface. Due to the increasing importance of these issues, these existing feedstock-conversion related efforts are being organized into FCIC, which will be fully integrated and functional in FY 2018. The consortium is funded primarily by three BETO program areas: (1) Feedstock Supply and Logistics (FSL), (2) Conversion Research and Development (R&D), and (3) Demonstration and Market Transformation (recently renamed Advanced Development and Optimization).

FCIC Support of Office Strategic Goals

The central concept behind FCIC includes managing feedstock quality characteristics to (1) optimize the amount of harvested biomass suitable for introduction into biomass conversion processes and conversion process yield, while (2) minimizing equipment downtime due to wear and tear, plugging, or fires.

FCIC's overall goal is to develop and demonstrate integrated feedstock/conversion processes that achieve >90% operational reliability (i.e., time on-stream), within the constraints of the established cost targets.

The guiding principle for FCIC is that feedstock's physical, chemical, and mechanical characteristics are primary design considerations for process development, scale-up, and integration. Understanding and managing these characteristics will reduce the cost of production and reduce the risk to sustainable biorefinery operation.¹²

¹² The FCIC overview was provided by Kevin Kenney at the Peer Review; it is posted online at https://energy.gov/sites/prod/files/2017/08/f35/fcic_overview.pdf.

FCIC Support of Office Performance Goals

FCIC supports four of the Office success indicators/milestones as published in BETO's *Strategic Plan for a Thriving and Sustainable Bioeconomy*¹³ and BETO's *2016 Multi-Year Program Plan*¹⁴:

- By 2018, start to develop a biomass feedstock grading or classification system for energy production and other end uses
- By 2019, develop and provide a framework for biomass quality grading systems for at least one woody and one herbaceous biomass supply shed associated with an existing or planned demonstration-scale (or larger) biorefinery
- By 2020, determine the impact of advanced blending and formulation concepts on available volumes that meet quality and environmental criteria, while also meeting the \$84/dry ton delivered cost target (\$2014), including grower payment/stumpage fee and all logistics costs
- By 2022, validate one blendstock for thermochemical conversion and one blendstock for biochemical conversion at a scale of 1 ton/day while also meeting the \$84/dry ton cost target, including grower payment/stumpage fee and logistics costs.

FCIC Approach for Overcoming Challenges

FCIC efforts are focused on feedstock-conversion interface issues, such as the following:

- Determining the required particle size and distribution for feedstock handling and conversion
- Minimizing equipment wear

- Minimizing fire and dust explosion risk
- Introducing feedstocks into conversion processes against a pressure gradient
- Understanding process yield variation as a function of physical and chemical characteristics of feedstock materials.

Effective communication between FSL and Conversion R&D researchers on conversion performance as a function of feedstock physical and chemical quality parameters and preprocessing operations is critical to developing an economically viable and sustainable value chain. Feedstock-conversion interface efforts therefore emphasize correlating conversion performance characteristics—such as product yield, quality, and process kinetic parameters—with the physical and chemical characteristics of the feedstock and preprocessing operating conditions to define ranges of conversion process input specifications that permit reliable and routine achievement of techno-economic and environmental targets. This effort also develops and produces a suitable variety of preprocessed feedstocks for testing in bench-scale reactors for different conversion pathways. Larger quantities of specific feedstock(s) that meet(s) conversion in-feed specifications will also be prepared for scale-up testing and verification of conversion process performance.

The Biomass Feedstock Library, an element of the Biomass Feedstock National User Facility (BFNUF), is also included in FCIC. The library includes information on sample origin and agronomic treatments and enables users to access all data related to raw or preprocessed biomass samples and any conversion process intermediates. This allows subsequent analyses conducted on any sample to be linked to the sample's source and all

¹³ U.S. Department of Energy, Bioenergy Technologies Office (BETO), *Strategic Plan for a Thriving and Sustainable Bioeconomy* (BETO, December 2016), https://www.energy.gov/sites/prod/files/2016/12/f34/beto_strategic_plan_december_2016_0.pdf.

¹⁴ U.S. Department of Energy, Bioenergy Technologies Office (BETO), *Multi-Year Program Plan* (BETO, March 2016), https://www.energy.gov/sites/prod/files/2016/07/f33/mypp_march2016.pdf.

related publications relevant to that sample. Library data improve understanding of the impact of feedstock variability on conversion process performance characteristics and biofuel production costs. The Biomass Feedstock Library data and physical samples are available at bioenergylibrary.inl.gov, or via the Bioenergy Knowledge Discovery Framework at bioenergykdf.net.

FSL REVIEW PANEL

Name	Affiliation
Gerson Santos Leon*	Abengoa
Brandon Emme	ICM Inc.
Emily Heaton	Iowa State University
Phil Marrone	Leidos
F. Michael McCurdy	Leidos
Lucca Zullo	VerdeNero LLC

*Lead Reviewer

TECHNOLOGY AREA SCORE RESULTS

Average Weighted Scores by Project

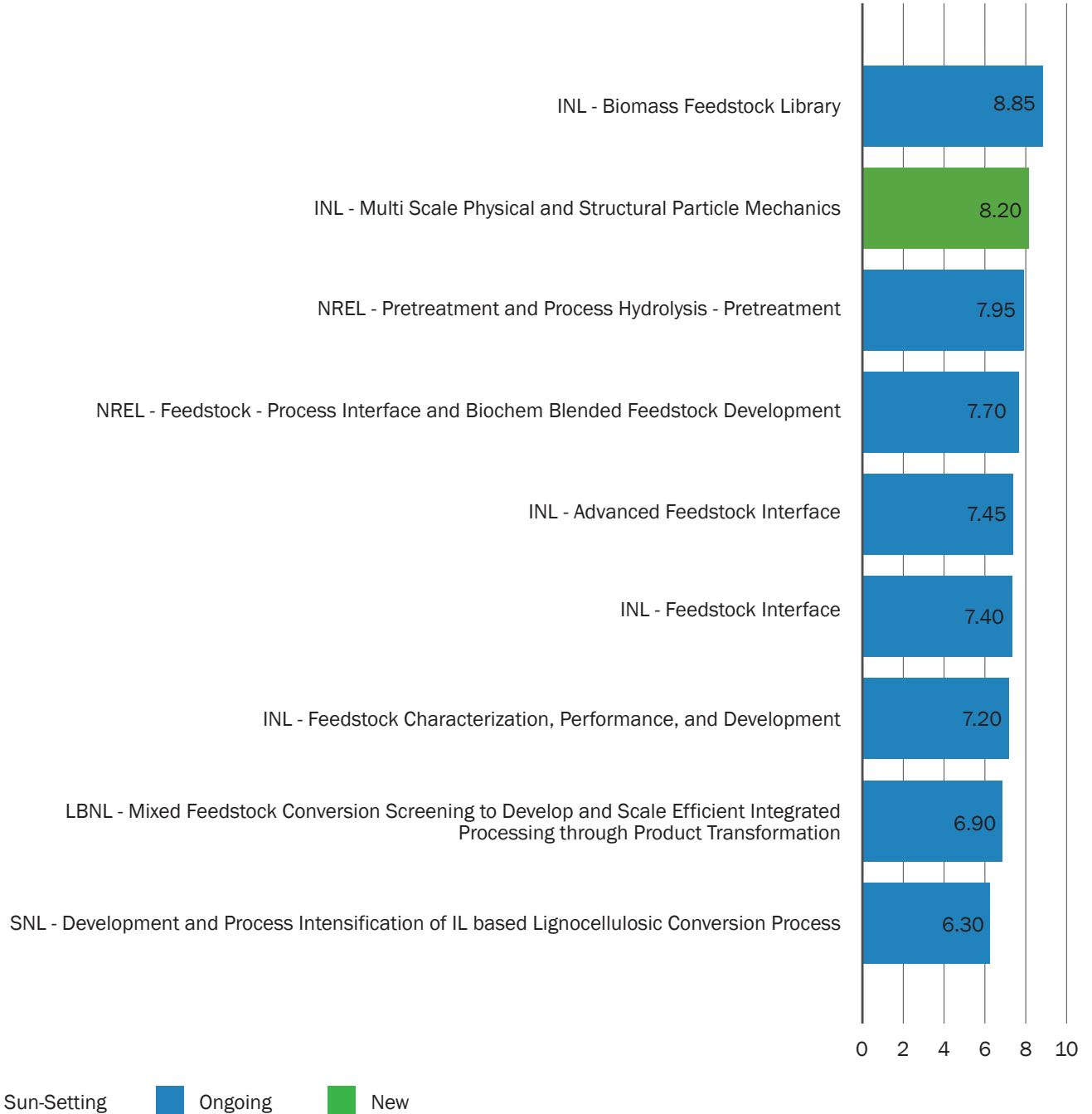

FCIC REVIEW PANEL SUMMARY REPORT

Prepared by the FCIC Review Panel

Collecting, delivering, cleaning, and preprocessing biomass substrates for biofuels and chemicals conversion is one of the most underestimated challenges in biomass-to-fuel conversion. Industry believed that engineered solutions were available for the design, construction, and operation of the first commercial facilities, but this belief has been proven wrong. Front-end processing has been problematic and very expensive for the first few pioneer plants. Full-scale biomass transport issues (e.g., biomass plugging and ash abrasion) are plaguing the startup, commissioning, and operation of these pioneer plants even after insights have been realized from building and operating pilot and demonstration facilities.

This summary report is intended to provide high-level, general comments to BETO program managers to help guide and focus FCIC projects to increase the return on the public investment. This summary does not necessarily reconcile the opinions of the individual reviewers to form a consensus; it is only intended to capture general themes and ideas for the manager's consideration. Detailed comments are provided in the individual project reviews. In addition, the Panel commends BETO for recognizing the importance of FCIC activities by adding this session to the Peer Review process.

Impact

These activities will help guide equipment suppliers, process designers, and plant operators to lower the risk associated with biomass handling, transport, and conversion of heterogeneous biomass feedstock. This is especially true of the Biomass Feedstock Process Demonstration Unit (PDU) at Idaho National Laboratory (INL), which provides a platform for the develop-

ment of design principles for the handling, transport, and preprocessing of biomass feedstock. This PDU will help define the concepts and strategies for FCIC considering the requirements of the feedstock and conversion processes. The preprocessing requirements for thermochemical and biochemical conversion are different and lend themselves to leverage various biomass attributes (e.g., the biochemical process may tolerate higher levels of moisture and ash while a thermochemical process may not).

Innovation

Following are examples of FCIC activities with significant potential to improve the operation and profitability of biomass biorefineries:

- The depot and blending concepts should help lower the cost and improve the quality of the feedstock for a mature biorefinery industry.
- Intelligent feedback control systems for biomass handling and processing will increase the operability and availability of the production plants.
- Development of heterogeneous biomass transport models for the design community have great potential. The current models based on biomass combustion and pelletization, pulp and paper, and sugar industries are insufficient to adequately meet the design requirements of the biorefinery industry.

Synergies

The Panel reviewed a portfolio of projects that are examples of forthcoming FCIC projects. If the intent is to address this critical subject, FCIC should develop an integrated plan to connect and address the near-, mid-, and long-term needs of FCIC. There are significant knowledge and capabilities at the national laboratories, commercial industrial partners, and biomass industries to help define and support the development of an integrated FCIC plan.

Focus

The recommendations of the Biorefinery Optimization Workshop¹⁵ should be the basis for the goals and objectives of the FCIC. The consortium should focus its activities on the development and implementation of an integrated, cohesive plan based on Workshop recommendations and balance the portfolio of projects to meet the objectives of the plan.

Commercialization

The present FCIC portfolio of projects is too broad and must be aligned with the recommendations of the Biorefinery Optimization Workshop to better the commercialization objectives of BETO.

Recommendations

Following are the recommendations of the Review Panel:

- Identify and appoint a diverse industrial guiding committee to build on the recommendations of the Biorefinery Optimization Workshop to continue capturing real world technical and operational issues
- Develop an integrated FCIC plan based on the recommendations of the Biorefinery Optimization Workshop and the guiding committee considering the different requirements of the various thermochemical and biochemical conversion processes
- Balance the portfolio of projects to include near-, mid-, and long-term FCIC projects. Wind down or terminate projects that do not fit in the portfolio.
- Perform a trade-off evaluation of the depot and blending concepts to validate the solutions and guide FCIC activities. The evaluation should consider and help define the battery limits of the depot and blending facility, the preprocessing require-

ments, and the capital allocation, e.g., if the interface is defined at the throat of the reactor, where the preprocessing will be conducted and how the biomass will be delivered. In addition, the techno-economic analysis (TEA) will have to consider where the preprocessing capital allocation will be made, at the blending depot or the plant.

FCIC PROGRAMMATIC RESPONSE

Introduction/Overview

BETO sincerely thanks the Peer Review Panel for its hard work, constructive reviews, and insights in shaping the emergence of FCIC. The Panel commended BETO for recognizing the importance of FCIC, and we would like to reiterate our strong commitment to this effort going forward. Reviewers described INL's Biomass Feedstock Library and Biomass Feedstock PDU efforts as important projects and crucial to FCIC. They also pointed to the National Renewable Energy Laboratory's (NREL's) Pretreatment and Process Hydrolysis project as having far reaching significance.

We very much appreciate the Panel's comment that FCIC's activities will help guide equipment suppliers, process designers, and plant operators to lower the risk associated with biomass handling, transport, and conversion of biomass feedstock. Risk reduction is key to the evolving bioeconomy sector, a focus of FCIC, and an area where FCIC can have significant impact. Our goal is to use a multidisciplinary approach to innovation in technology development. We appreciate the Panel members' recognition of the innovations in use of depots, blending, feedback controls, and advanced transportation systems. The lack of commercial facilities for testing will be handled through INL's and NREL's feedstock and conversion PDUs and simulation modeling. We agree to the importance of having industry involvement as well, and have made this a priority. We also agree that an immediate

¹⁵ The Biorefinery Optimization Workshop presentations and summary report are available on the workshop web page: <https://energy.gov/eere/bioenergy/events/biorefinery-optimization-workshop>.

need and goal is to develop an operating plan to address industrial involvement and the best ways to integrate the various activities for a synergetic approach. The individual recommendations are addressed below.

Recommendation 1: Establish an Industrial Advisory Board

It has been BETO's intention from the onset to establish an industrial advisory board for FCIC. The advisory board will include members from a wide range of sectors including agriculture and forestry harvesting equipment manufacturers, biomass producers and suppliers, preprocessing equipment manufacturers, co-product distributors, conversion technology developers, biorefineries, and end users. A workshop in FY 2018 will bring together diverse stakeholders to crystalize FCIC's priorities and approaches.

BETO will support the national laboratory partners and FCIC researchers to engage industry stakeholders, gather input, and solicit feedback via activities such as listening days, workshops, and webinars. A "virtual scale-up team" will be created to assist companies that are preparing to scale their technologies. The team could lead to cost-shared collaborative R&D with industry.

Recommendation 2: Develop an Integrated FCIC Plan

Three BETO program areas—FSL, Conversion R&D, and Advanced Development and Optimization (previously Demonstration and Market Transformation)—are working closely with the national laboratories during the Merit Review cycle to develop well-integrated, impactful work plans for FY 2018–FY 2020.

A package of new projects, involving tight coordination among seven national laboratories, is being developed to cover the range of FCIC research priorities to help enable >90% operational reliability in biorefineries. The following are the current FCIC project titles:

- Feedstock Variability
- Feedstock Informed Process Development

- Modeling of Biomass and Feedstock Physical Performance
- Integrated Analysis
- Industry Engagement.

Recommendation 3: Balance the Portfolio and Wind Down Out-of-Scope Projects

All of the current FCIC-relevant annual operating plans (AOPs) will be terminated at the end of FY 2017. FCIC work plans are now included in a package of new AOPs designed to operate on the same 3-year cycle (FY 2018–FY 2020), and are undergoing independent review as well as receiving strong guidance from BETO. All projects are focused on mutually agreed upon, well-integrated FCIC goals and objectives. The overall goal is to help enable integrated feedstock/conversion processes that function at >90% operational reliability (i.e., time on-stream). FCIC projects will appropriately balance near-, mid-, and long-term activities, with a near-term focus on operational issues caused by feedstock variability. Feedstock variability is a high impact challenge because several integrated biorefineries (IBRs) have failed due to unexpected operational issues. Due to feedback received from the Peer Review Panel, depot and blending projects will be longer-term activities instead of near-term.

Recommendation 4: Perform TEA of the Depot and Preprocessing Concepts

BETO agrees on the importance of understanding the downstream technical and financial impacts of feedstock quality parameters, potential preprocessing operations, and the depot concept for FCIC activities on overall process reliability.

FCIC's Integrated Analysis project will evaluate the integrated value chain, which spans the field-to-fuel, system-wide impacts of feedstock variability on cost, down time, achievable biofuel yield, and environmental sustainability trade-offs to understand the path forward for IBRs to realize reliable and profitable operations.

MULTI-SCALE PHYSICAL AND STRUCTURAL PARTICLE MECHANICS

(WBS #: 1.2.1.3)

Project Description

Feeding and handling represent a substantial challenge in biomass feedstock supply systems. Conventional systems for dry bulk solids are generally not suitable for lignocellulosic biomass, which typically has large particle size variations, low densities, and high compressibility. Methods do not exist to either physically characterize or computationally model the complex mechanical response of such materials. As such, the primary objective of this project is to develop robust mechanical characterization methods and computational models that can be applied to reliably predict the flow of biomass materials at all scales in a wide range of feeding and handling operations. This objective will

Recipient:	Idaho National Laboratory
Principal Investigator:	Tyler Westover
Project Dates:	10/1/2016–9/30/2017
Project Category:	New
Project Type:	AOP
DOE Funding FY 2014:	\$200,000
DOE Funding FY 2015:	\$0
DOE Funding FY 2016:	\$0
DOE Funding FY 2017:	\$650,000

be accomplished in several steps. First, materials will be physically and mechanically characterized at the individual particle and bulk solid scales. Next, discrete element (e.g., particle) models at bench scale will be combined with material characterization to determine the multi-dimensional and time-sensitive stress-strain relationships (e.g., constitutive relations) that govern the flow behavior at all relevant conditions. These constitutive relations will then be used in finite-element or control-volume models to predict the flow behavior at all scales. Finally, bench- and pilot-scale physical tests will be conducted to validate the flow models. The resultant

Weighted Project Score: 8.2

Weighting: Approach–25%; Relevance–25%; Future Work–50%.

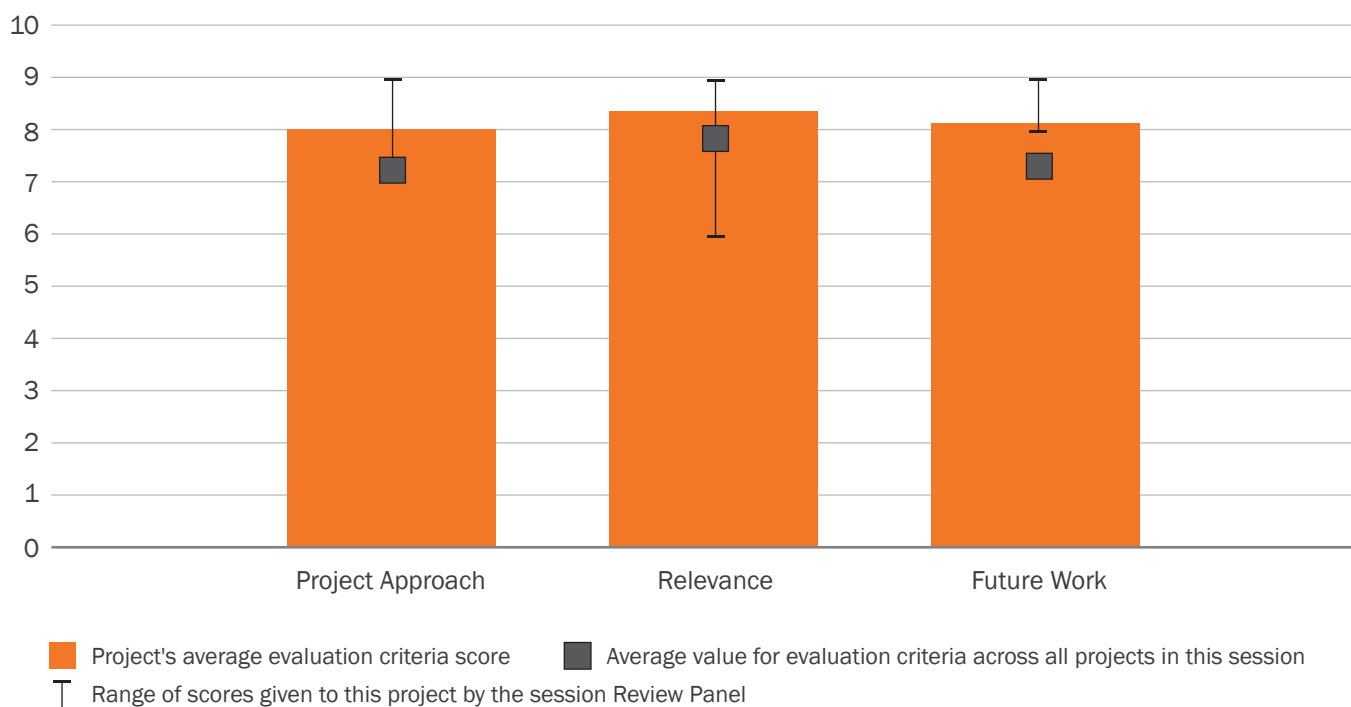

characterization methods and flow models will be used to control the sensitivity of feeding and handling operations to variation in biomass properties.

Overall Impressions

- Overall, this project seems like an effective balance between empirical data collection and model development/validation and is a good template for how BETO might effectively frame other projects. If it really does relate well to commercial scale as proposed, this should be directly practical today, while making considerable advances to the state of the art in both engineering and material science.

The degree of involvement from industry experts needs to be described. If we assume the pioneer plants involved experts in their design, one might wonder why this kind of analysis (e.g., work by Jenike and Johanson Inc.) has not already been done if they wanted to be dominant in the nascent biomass industry. Can we understand/quantify the degree of de-risking the output from this project? The project needs to have a high level of relevant industrial partner/pioneer interaction helping to design and analyze the experiments.

The relative impact of the milling example is scary. With high levels of anticipated wear on the milling systems, there will be transient flow quality. How will the project deal with this dynamic engineering requirement?

A key deliverable should be a series of protocols that can be applied to any feedstock. A relative scoring of different feedstock forms will also help grade biomass supplies.

Should the project also study flow aids? Knowing mitigation methods can be as valuable as knowing the design. The speaker mentioned part of the project will be to set quality limits on the feedstocks to keep them in controllable range.

- This is an excellent project that is starting to address the biomass feedstock conversion interface. Before it embarks on the testing program, the project should seek the input of industry and equipment suppliers to help prioritize and focus the development and testing effort.
- This is a good project of clear relevance for BETO. The challenge is to prevent it from being a pure science project by introducing more direct ties to vendors, operational recommendations, and explicit TEA.
- Overall, I really like this project and believe that it fits well within FCIC. There is a distinct lack of data for the design of biomass handling systems, and this work could fill a major gap. Better designed systems would also reduce the startup time of biorefineries and increase their availability. My only recommendation would be that some of the work focus on wet materials as many industrial partners use soak tanks to reduce silica and increase biomass availability, and these materials handle differently than dry materials.
- This project, which focuses on understanding and developing tools for predicting the behavior of biomass feedstock solids handling, is unique and of great importance. Solids handling problems are one of the biggest issues hindering operation at existing biorefineries, so this project addresses a critical industry need at this time. The approach appears to be straightforward and involves a good mix of experimental measurement testing with modeling. It will be important to tap into the expertise of the solids handling companies that are part of the team to ensure that the right issues are being addressed without “reinventing the wheel.” Also, developments should be tested at commercial scale to ensure assumptions are correct and because acceptance of results and any proposed feed handling modifications by industry will be critical to the project’s ultimate success.

PI Response to Reviewer Comments

- This project will continue to balance empirical data collection and model development/validation during each year of the project with the intent to bring both approaches to sufficient maturity that they can be ready for testing at commercial scale in future DOE-funded efforts. Establishing strong connections with operators and consultants in the industry is a high priority for this project. Once significant progress is made toward understanding the flow performance of dry materials, the intent is to start a similar effort for wet materials, which should be able to borrow many of the characterization and modeling approaches already developed for the dry materials.

We strongly agree that close collaboration with industry stake holders is necessary to identify the correct problems to focus on and also to deploy the solutions that are developed.

The degree of de-risking that this project will provide to biorefineries can be estimated by using a preliminary TEA to determine the impact of the project outputs on pilot-scale feeding and handling operations at INL and possibly partner institutions. The pilot-scale information will have to be extrapolated to commercial scale until commercial data

become available. Until then, it is clear that there are substantial cost incentives to reduce feeding and handling problems, and it is the hypothesis of this project that workable solutions need not be cost prohibitive.

Being aware of the potential for equipment wear to impact material flow properties opens opportunities to solve this problem before it becomes an issue. Equipment wear does not usually occur suddenly, so that if biomass flow properties can be measured real-time inline during processing, then it should be straightforward to use active monitoring to correct equipment deficiencies before they cause expensive failures. This approach is common in the pharmaceutical industry, which requires extensive testing for quality assurance in regard to determining appropriate intervals for equipment maintenance and replacement.

Looking more into flow aids is certainly advisable. The common approach of flow experts for handling springy materials is to design equipment to prevent over-pressures that may cause problematic elastic behavior.¹⁶ By investigating the fundamental flow behavior of biomass materials, we believe that insights can be gained into effective equipment designs that incorporate measures, such as flow aids, to facilitate flow at critical points.

¹⁶ For example, Jerry Johanson, "Bin and Feeder Design for Wood Chips and Other Springy Bulk Solids," *Powder and Bulk Conference Proceedings* (Chicago, IL, May 1989), <http://www.diamondbacktechnology.com/Articles-and-Papers.html>.

ADVANCED FEEDSTOCK PREPROCESSING

(WBS#: 1.2.2.1)

Project Description

To be successful, the Bioenergy industry requires a sustainable supply of low-cost biomass in sufficient quantities and with sufficient quality. This is challenging for several reasons: (1) biomass is not evenly distributed so few areas have a single biomass resource; (2) in areas with a single biomass types (e.g., corn stover), there are large ranges in compositions and characteristics; (3) methods to improve quality add cost; and (4) biomass is seasonal and degrades in storage reducing quality. Our approach is to mobilize low-cost and quality biomass and take advantage of the low cost to use preprocessing methods to improve quality. These preprocessed materials can then be blended with other available biomass to reduce cost, improve quality, and increase quantities available. Our methods include mechanical preprocess-

Recipient:	Idaho National Laboratory
Principal Investigator:	Vicki Thompson
Project Dates:	10/1/2009–9/30/2019
Project Category:	Ongoing
Project Type:	AOP
DOE Funding FY 2014:	\$1,350,000
DOE Funding FY 2015:	\$1,435,000
DOE Funding FY 2016:	\$1,275,000
DOE Funding FY 2017:	\$871,970

ing (i.e., air classification and sieving), chemical preprocessing (i.e., acid leaching, water washing, and alkaline extraction), and formulation. A parallel task developed cost models for preprocessing methods and TEA to target the best preprocessing technologies. We have developed a flexible method for optimizing all biomass resources in a region and meeting the required cost/quality/quantity targets. We demonstrated this by developing blends for fast pyrolysis using logging residues, clean pine, and construction and demolition waste that are air classified, acid leached, and formulated to be 16%–20% cheaper than clean pine.

Weighted Project Score: 7.5

Weighting: For ongoing projects, there is equal weighting across all four evaluation criteria: Approach, Relevance, Accomplishments and Progress, and Future Work.

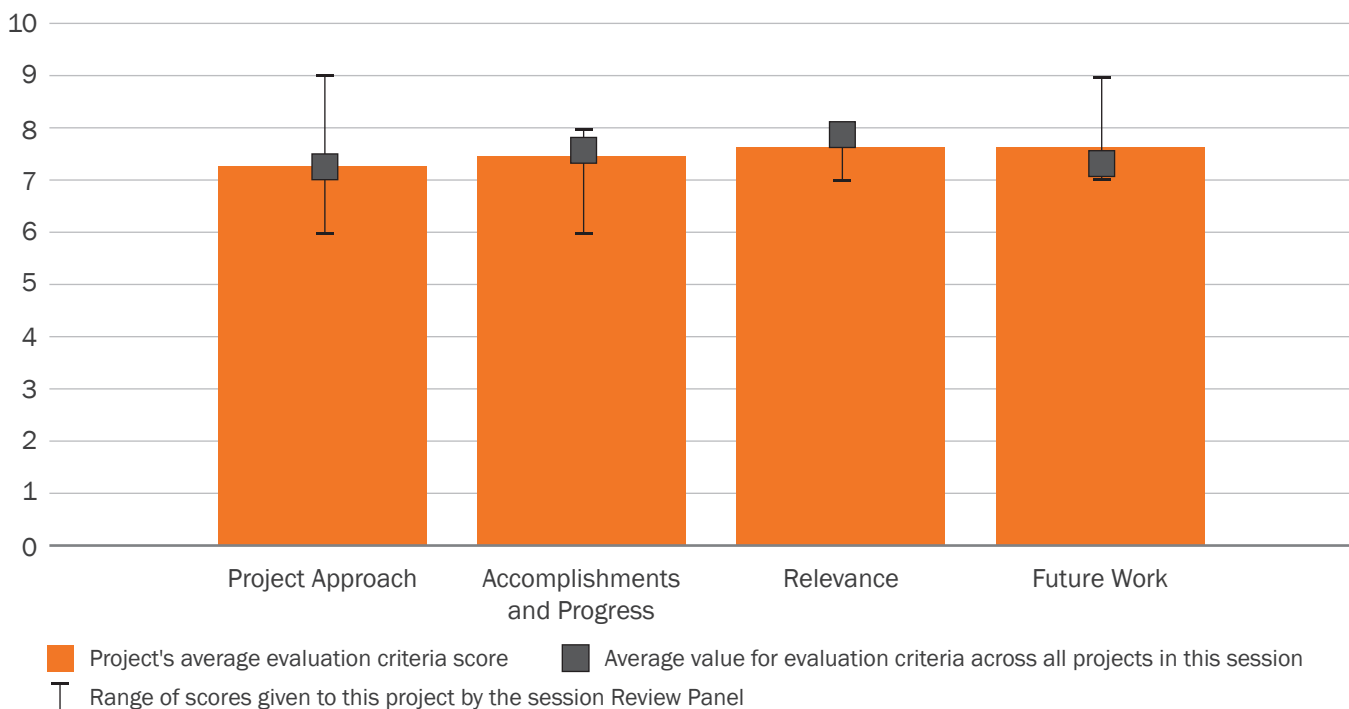

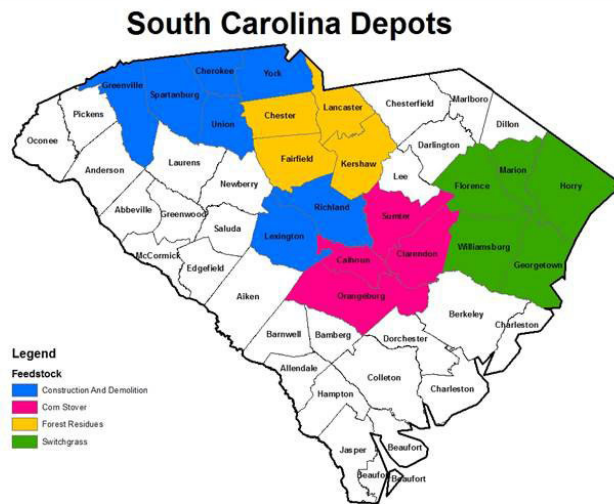

Overall Impressions

- Overall, this project uses a combined modeling and data collection approach that results in improved models as well as useful data. It is very useful for enabling improved decision making today for the industry, as well as providing data and improved tools for future work.
- This is interesting work and it is good to see national laboratory data backing up field observations.

It is a promising concept to blend in small amounts of cheap, low-quality materials without much, if any, penalty. It might be interesting to consider then how this would tie into the grading project; if there is not much of the cheap feedstock around where there really isn't a practical penalty, will the price still be lower?

A key concern around lower grade feedstocks is how it will fit with the new Food Safety Modernization Act (FSMA) that all ethanol plants that make animal feed co-product will have to comply with starting in 2017. This will require a higher level of lot traceability and diligence about the feedstock safety. I have some doubts if municipal solid waste will be allowed at all.

- The project provides additional preprocessing alternatives for industrial consideration with the objective of lowering the cost, reducing the risk, and increasing the quality of the feedstock.
- I struggled with this project which starts as a TEA of feedstock blends to meet a specific requirement and ends focusing on a very relevant, but only marginally connected to the main topic proposed of technique analysis to reduce abrasiveness of biomass on size reduction equipment.
- The project was a good one in that it examined processes that would be helpful for a number of different conversion platforms and that it demonstrated the efficacy of the air classification and leaching systems. This project fits squarely within FCIC and would be a good model going forward.
- This project, which focuses on investigating how the use of preprocessing steps and blending impacts feedstock cost and availability, is important in assessing how these parameters can be used to optimize feedstock properties for biochemical and thermochemical conversion processes. The results demonstrate clearly that use of air classification and leaching can achieve a significant improvement in key feedstock qualities, and that these preprocessing steps with the right combination of biomass feed blends can be used to design optimal feed choice strategies for meeting cost targets. Since it is not clear if the results shown represent the best options or are just examples of what is possible, it is recommended that a more systematic study of all variables be performed to map out the best combinations that will meet the desired cost and quantity targets. It is also important to examine the effects on the ultimate bioenergy product to ensure that any additional costs incurred to improve feedstock cost and quantity do not get hidden downstream and added to the more important final product cost.

PI Response to Reviewer Comments

The perceived disconnect between TEA and biomass abrasiveness comes from seeing two different projects. The bulk of the work shown represented the conclusion of a 3-year project which ended in 2016. We prepared a proposal for a new scope of work and chose to apply the methods we had previously developed to solve problems that the biorefineries are facing now (abrasion). The previous work scope had a different goal, which was to provide feedstocks to the biorefinery that met BETO cost, quality, and volume targets.

We will monitor the implementation of the FSMA and will make adjustments to our feedstock blends as necessary.

BIOMASS FEEDSTOCK LIBRARY

(WBS#: 1.2.2.2)

Project Description

The Bioenergy Feedstock Library is creating a central repository for biomass/feedstock samples, information, and research data. Biomass and feedstocks are the foundation of all activity in BETO and understanding the qualities, characteristics, variability, and operations of feedstocks is critical to advancing a bioeconomy. This project advanced from collecting BETO research samples to develop a public web application for secure, reliable access to data and robust methods to examine it. The project continues to gather samples of physical biomass which it shares with researchers to advance analysis understanding. The Library provides tools and methods to help learn from the research data. To effectively meet the needs of the community, the Library is challenged to gather a more complete and rich data set,

Recipient:	Idaho National Laboratory
Principal Investigator:	Victor Walker
Project Dates:	10/1/2009–9/30/2017
Project Category:	Ongoing
Project Type:	AOP
DOE Funding FY 2014:	\$750,000
DOE Funding FY 2015:	\$885,000
DOE Funding FY 2016:	\$752,250
DOE Funding FY 2017:	\$993,250

to identify reliable answers to critical questions, and increase visibility and use. To meet these challenges, the Library underwent a redesign and introduced several public and private tools that aggregates data into usable formats. These tools include graphing, blend prediction, variability examination, and tools to determine the least cost formulations with quality constraints. The Library continues to focus on increasing use by external groups, gathering targeted data sets, increasing categorization of the data, and providing more powerful tools to understand variability sources and impacts of operations.

Weighted Project Score: 8.9

Weighting: For ongoing projects, there is equal weighting across all four evaluation criteria: Approach, Relevance, Accomplishments and Progress, and Future Work.

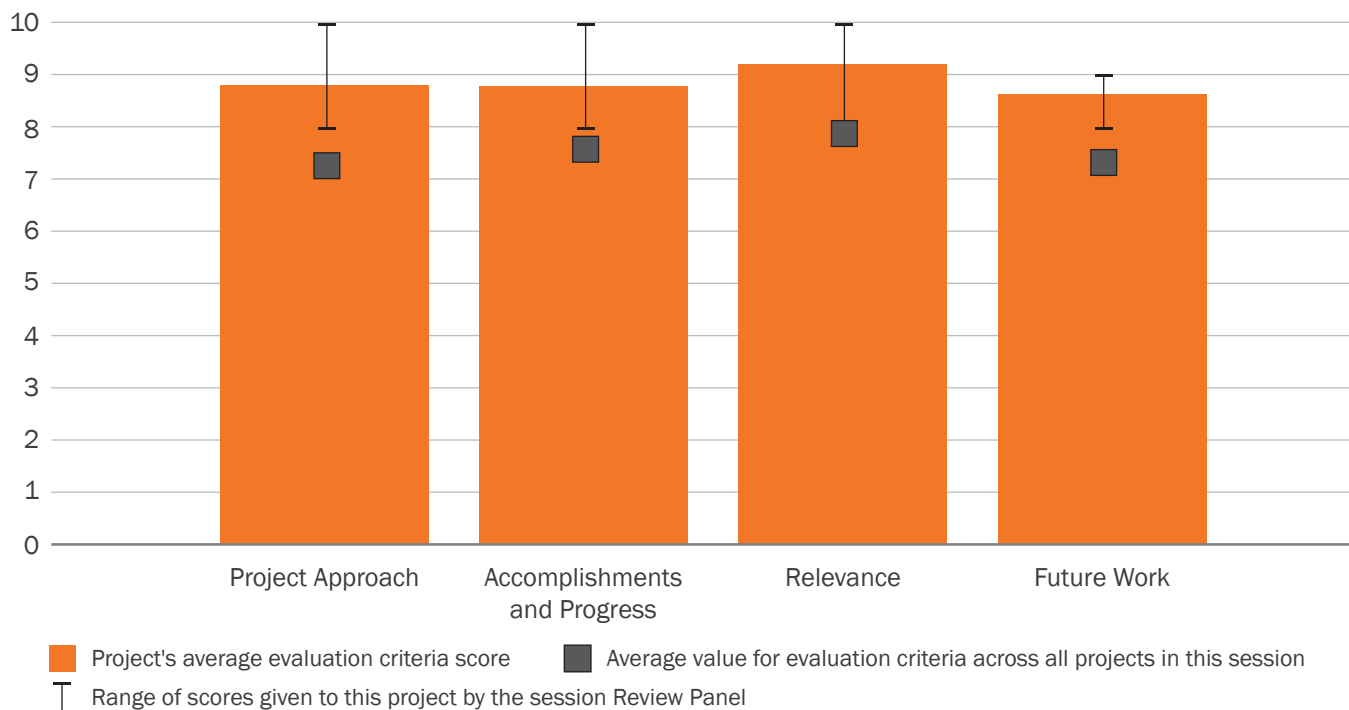

Users around the world

1 512

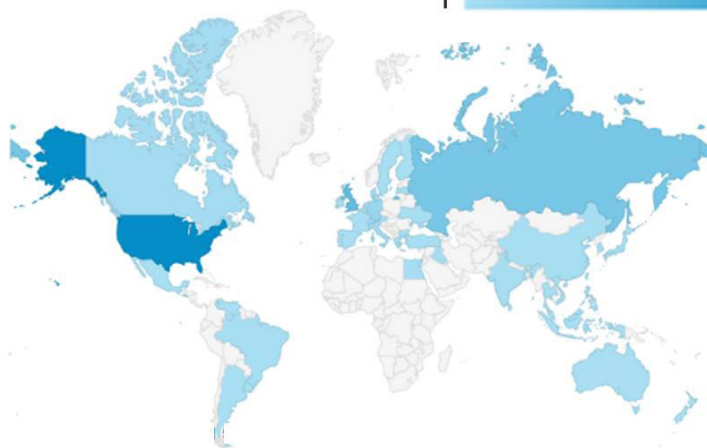

Photo Courtesy of Idaho National Laboratory

Overall Impressions

- This library is critical to BETO’s mission. It is one of the most potentially impactful projects in the BETO portfolio because it underpins not only feedstock, but also sustainability and conversion work. Providing data resources is one of the single most effective ways to inform industry and academia, enabling synthetic understanding and avoiding duplicative or myopic activities. It is important that the library team be empowered to make the library connect to the Bioenergy Knowledge Discovery Framework (critical!) and the broader data community. It is also essential that other BETO projects are using the library data (and its variability!) to inform their work. Predictive modeling about biomass, feedstock, and feedstock blends is useless without informing those models with prior information. See papers by Dave LeBauer and/or Michael Dietze.

A lot of great, meaningful information is accumulated and into a myriad of usable forms in the Library. It seems like a rather daunting task for a novice to come into the system and harvest value from it. The speaker described a relatively recent effort to produce tutorials and support resources so that industry and academia can get adept at the information quickly as the database is made public.

A danger to any database of information like this is the context/history of the data. As we learn and get smarter, the information we collect gets more relevant; but what happens to our history/memory of the past? Is there are filter of some sort to help qualify some data as more relevant than others? Do some data have an expiration date? What if the Laboratory Analytical Procedures (LAPs) methods change over time? Do data get flagged when things like this occur as part of learning? The speaker described the project’s quality control methods to help this challenge. Should it also include (perhaps prioritized by data relevance and volume) a round of reaching out to past data contributors to interview them and gain this added level of data identity that experience has shown is also important with the data?

- This is an excellent effort to create a common baseline for the academic and industrial communities to facilitate the development and growth of the industry.
- The Library is a highly relevant project. As mentioned, this is an area where BETO R&D can fill a need that is unlikely to be occupied by the private enterprise. The key challenge for the developers will be to drive an aggressive adoption. On the other hand, the more successful they will be in driving

adoption, the more the tools will be recognized as authoritative by the researchers generating data in a virtuous cycle of expanding adoption and content of the database. These considerations could and should drive future work.

- This is a very important project that transfers data from the national laboratories to the industrial users involved in the deployment of technologies. The collection of the data, tools developed, and outreach have been impressive to date. The composition, moisture, fuel properties, and particle data look particularly robust. A focus on rheology and other material handling data in the near term would be particularly useful for future work.
- Though this project does not involve generation of any new experimental data or models, it is arguably one of the most important projects that BETO has implemented. The value of a large database that can be publicly accessed, sorted, and explored cannot be underestimated and can make the jobs of all stakeholders much easier and efficient. The storage of physical samples as well as analytical data is another advantage which makes this project even more unique and valuable. The biggest challenge this project needs to address is increasing public awareness of this incredible resource, as this reviewer, for example, was previously unaware of the extent and availability of this database.

PI Response to Reviewer Comments

- Thank you to the reviewers for their excellent input and feedback. I appreciate that the significant impact that this work can have on the industry is evident and I agree with many of the challenges you have identified.

Some of these challenges, such as ensuring that we can gain greater visibility and usability of the library tools and database, are ones that require us to work with partners and increase the ties to the Library. We are working toward this and hope to make some progress as part of our current year work. For instance, we will be completing a focused effort on creating tools and policies for external research groups to contribute and cite their data in the Library application. We anticipate an academic paper to increase visibility of these results and any input into the structure of these policies and tools is welcome.

I agree with the desire to have the Library connected with more related data sources and we are proposing some focused effort in this area into the next BETO cycle. We also will work on increasing robustness of the data sets by requesting more data (such as additional physical characteristics) from related projects and ensuring that most relevant BETO projects are represented.

Through all our efforts, the quality of the data is critical and we are currently working on ways to make it clearer what the data represent so that users understand the results and comparisons. So, rather than removing older data we hope to make it clear what may have changed from one set of data to another set of data. We hope that the history and context of the data can be a significant learning environment.

Overall, we anticipate that further focus on visibility, usability, connectivity, and quality can make this an even more effective tool.

FEEDSTOCK-PROCESS INTERFACE AND BIOCHEM BLENDED FEEDSTOCK DEVELOPMENT

(WBS#: 2.2.1.101 and 2.2.1.102)

Project Description

Densification and blending are strategies to reduce the cost of feedstock logistics, maintain quality, and provide consistent feedstock properties. Densification reduces transportation costs, while producing feedstock with consistent physical properties. Blending diversifies biomass supply to include low-cost biomass resources that reduce cost and risk associated with reliance on a single resource. Current data on the impact of these combined strategies on sugar and lignin yields are limited. During FY 2015/17, this project evaluated more than 25 feedstocks and blends and developed predictive models based on laboratory-scale conversion testing. A study, examining blends of corn stover, switchgrass and waste,

Recipient:	Idaho National Laboratory/ National Renewable Energy Laboratory
Principal Investigator:	Alison Ray/Nick Nagle
Project Dates:	10/1/2006-9/30/2018
Project Category:	Ongoing
Project Type:	AOP
DOE Funding FY 2014:	\$550,000
DOE Funding FY 2015:	\$1,625,000
DOE Funding FY 2016:	\$1,625,000
DOE Funding FY 2017:	\$1,625,000

grass clippings, combined total glucose and xylose yields from laboratory-scale, dilute acid pretreatment, and enzymatic hydrolysis with grower payment data from the U.S. Billion-Ton Update: Biomass Supply for a Bioenergy and Bioproducts Industry to develop a model for blend formulation based on cost and performance. In FY 2016, corn stover, switchgrass, and a 50:50 blend of corn stover and switchgrass, both pelleted and non-pelleted formats were dilute acid pretreated under continuous operation and process-relevant conditions.

Weighted Project Score: 7.7

Weighting: For ongoing projects, there is equal weighting across all four evaluation criteria: Approach, Relevance, Accomplishments and Progress, and Future Work.

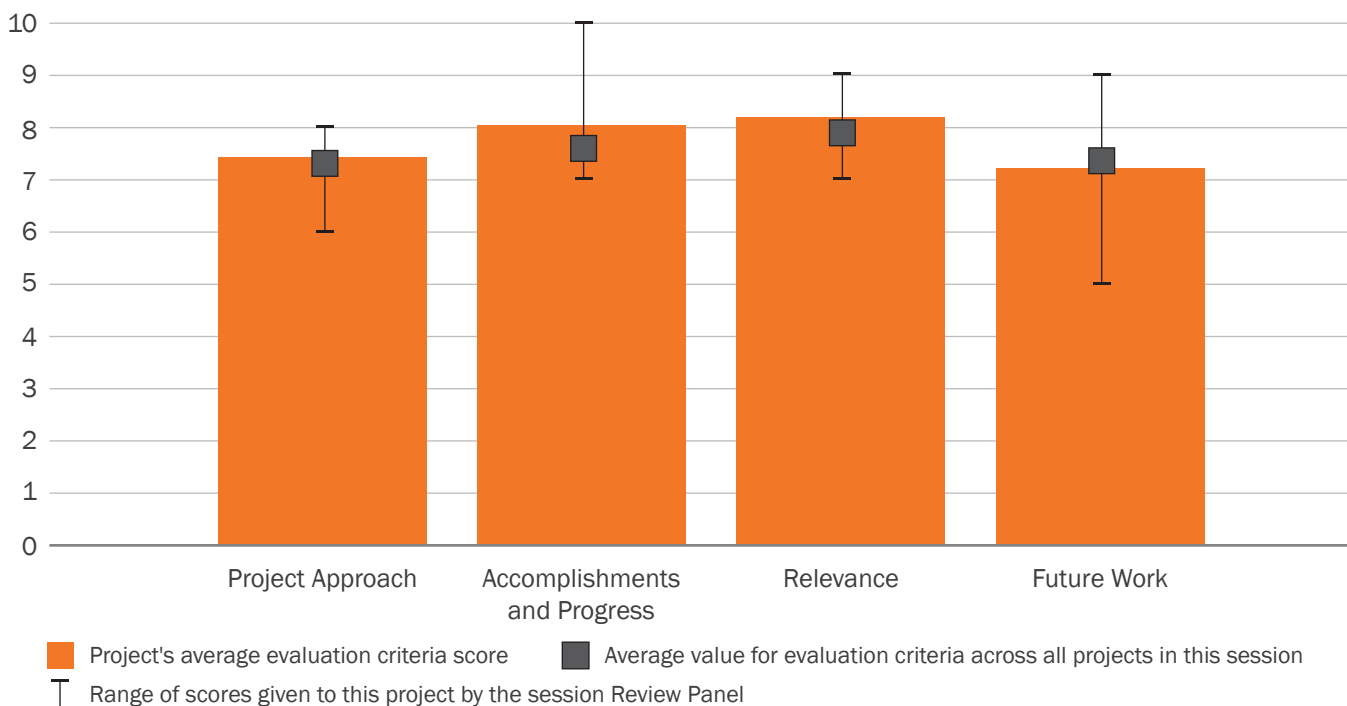



The 50:50 blends of corn stover and switchgrass showed improved performance with reduced torque loading in the screw feeders and similar sugar yields when compared to corn stover. These results demonstrate that blending and densification provide great promise for more cost-effective downstream processing.

Overall Impressions

- My assessment based on my understanding of the work presented is that this project is not well informed by existing work elsewhere in BETO. It might be using experimentally sound biochemical science, but it is not clear that the project is examining anything that actually matters for BETO.
 - The speaker mentioned that the blend will still be somewhat local; does this fit with any goal to normalize/commoditize the biomass with Analysis of Sustainability, Scale, Economics, Risk and Trade? I expect densification and blending will allow feedstocks to come from larger distances. If the feedstock is local, does the cost of pelleting densification still make it reasonable to pursue from a variability/processability standpoint? I would like to see some information come out about the TEA benefits and trade-offs to give some clarity and get some vetting from industry.
- Overall the project results are interesting and probably very relevant for the nth of a kind facility if one assumes that future biomass feedstock supply systems are based on blending and densification.
 - Overall impressions are similar to other projects around this general area:
 - The effort has merits and the approach is relevant especially for future IBRs.
 - The execution is somewhat disjointed although individual impressive results can be found.
 - The TEA should be strengthened.
 - It appears that there is a duplication of effort with other similar project and there would be benefits in some coordination.
 - While relevant for future IBRs, this whole effort seems of limited applicability to the few existing IBRs which are struggling with a variety of interface problems. Can we find some more connection to today's IBR's problems without losing the long view approach to these projects?
 - Overall, this is important work in that it will help the industry with availability concerns and blending for cost/availability in the medium term. The size impact on yield is an important learning as well as the improvement on yield/narrowing of the yield distribution with a blend. The project does seem too focused on deacetylation, and may benefit from a refocus on the more common dilute acid hydrolysis processes so that the work has the maximum impact.

PI Response to Reviewer Comments

- Given the time limitations, we did not explicitly discuss linkages and identify specific research efforts between FCIC and the FSL and Conversion Program Areas that were previously presented and regret this wasn't clear to the reviewer. This project is informed by the Feedstock Supply Chain Analysis (TEA), Bioenergy Feedstock Library, Advanced

Preprocessing, Feedstock Characterization and Densification projects at INL. In addition, we work in conjunction with conversion platform projects at NREL-Biochemical Platform Analysis (TEA), Pretreatment and Process Hydrolysis, Lignin Utilization, and Lawrence Berkeley National Laboratory Mixed Feedstock to look at the impact of advanced feedstock preprocessing strategies on sugar and lignin-derived fuels and co-products for meeting \$3/gasoline gallon equivalent cost target. This project directly supports larger BETO goals and objectives outlined in the 2016 *Multi-Year Program Plan*:

- By 2017, validate sustainable feedstock supply and logistics cost of \$84/dry ton at conversion reactor throat (including grower payment and logistics cost) for at least one biochemical and one thermochemical conversion process)
- By 2018, select an integrated bench-scale lignin deconstruction and upgrading strategy for valorization of lignin in a hydrocarbon fuel production process
- By 2020, determine the impact of advanced blending and formulation concepts on available volumes that meet quality and environmental criteria, while also meeting the \$84/dry ton cost target (\$2014) (including grower payment/stumpage fee and logistics costs)
- By 2022, validate one blendstock for thermochemical conversion and one blendstock for biochemical conversion at a scale of 1 ton per day while also meeting the \$84/dry ton cost target (including grower payment/stumpage fee and logistics costs).

We agree with the reviewer: addressing the challenges faced by the existing IBRs is a critical near-term issue. In FY 2018 we will be re-scoping our AOPs to provide more resources for IBR issues, specifically focusing on feeding and handling biomass at the biorefinery. Integrated efforts between the laboratories will allow for both the near-term focus on IBR challenges and on achieving longer-term BETO goals.

We will continue to use dilute acid hydrolysis (pretreatment) and enzymatic hydrolysis as the baseline conversion process to evaluate new/existing feedstocks and feedstock formats. As this work is integrated with the Pretreatment and Process Hydrolysis project, we will employ deacetylation, where it has demonstrated that it can reduce variability in feedstock performance.

We agree with the reviewer that there are factors, beyond yield, associated with densification that affects the overall process. Some of the initial work will happen in later FY 2017--guided by TEA, we'll be producing data to compare several types of densification processes to determine cost/benefits associated with each format.

Thanks for the opportunity to clarify this. A more accurate statement would be that blends will be defined regionally. In the Advanced Feedstock Supply System model, biomass pellets need not be only from local sources, as they are densified in distributed depots and transported to regional blending terminals. Individual biomass pellet sources (blendstocks) need not meet any given set of specifications; however, the blended feedstock meets all specifications for a given conversion process. This includes composition, feeding, handling and aerobic stability requirements. In the sense of a commodity, only the feedstock blend meets all of the requirements. While densification will allow for larger economic supply radii, there will still be an economic benefit to being able to utilize materials that are available locally. In addition to the transportation benefits, densification improves feeding and handling, material stability, and compatibility with existing grain system infrastructure.

Thanks to all of our reviewers—your feedback will be used to focus FY 2018 AOPs and advance FCIC goals.

DEVELOPMENT AND PROCESS INTENSIFICATION OF IONIC LIQUID–BASED LIGNOCELLULOSIC CONVERSION PROCESS

(WBS#: 2.2.1.103 and 2.2.1.104)

Project Description

Renewable energy technologies are being looked at as significant new sources to meet our current and future energy needs. Cellulosic biomass is an important source for the production of biofuels and bioproducts. Biomass feedstock costs remain a large contributor to biofuel production costs. Feedstock blending using municipal solid waste (MSW) with year-round availability and low cost could decrease the feedstock cost to achieve BETO feedstock cost target of \$84/ton. However, MSW utilization to reduce feedstock must be investigated since current biomass conversion technologies are not feedstock flexible and have a low tolerance for feedstock heterogeneity. Ionic liquid–based pretreatment technol-

Recipient:	Sandia National Laboratories/Lawrence Berkeley National Laboratory
Principal Investigator:	Seema Singh/Ning Sun
Project Dates:	10/1/2013–9/30/2016
Project Category:	Ongoing
Project Type:	AOP
DOE Funding FY 2014:	\$150,000
DOE Funding FY 2015:	\$160,000
DOE Funding FY 2016:	\$175,000
DOE Funding FY 2017:	\$250,000

ogies for biomass conversion are novel approaches with the potential to overcome feedstock flexibility problem, and need to reduce enzyme and process consolidation to enable lignocellulosic biorefineries. The objectives of this AOP are to evaluate the (1) potential of MSW as a blending agent, (2) efficiency of ionic liquid–based technologies for conversion efficiency on blended feedstock, and (3) impact of ionic liquid and any MSW-derived inhibitors on downstream fermentation processes.

Weighted Project Score: 6.3

Weighting: For ongoing projects, there is equal weighting across all four evaluation criteria: Approach, Relevance, Accomplishments and Progress, and Future Work.

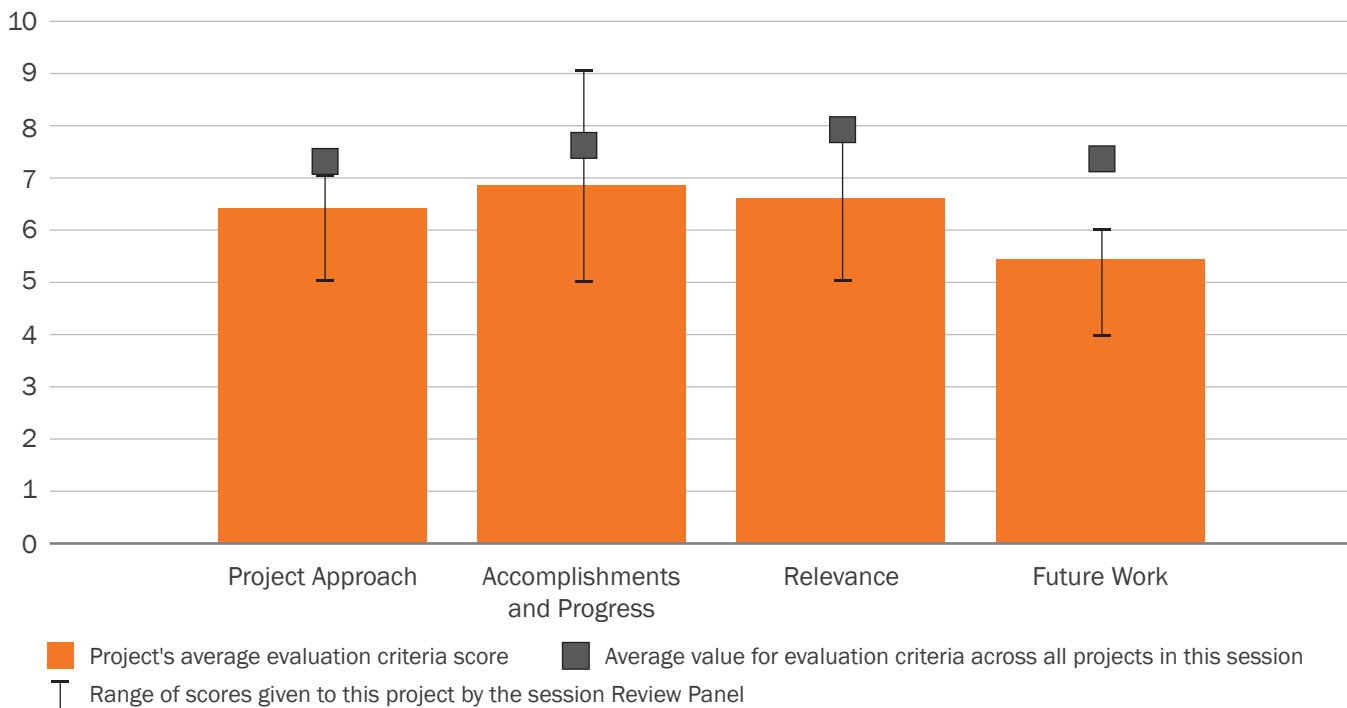



Overall Impressions

- Presentation of conversion data that only goes to 5–50 g/L is not relevant—data should be shown at TEA concentrations. It is not completely clear if the conditions are going to be relevant for larger scale and industrial conditions with reference to solids loading and practical needs for processing. Relevance needs to be more clearly defined and tested. What are the total solids limitations to these ionic liquids? Speaker stated 15%–20% Total Solids at different stages; have gone as high as 50% in past ionic liquid cases.

Catalyst use cost is historically the main issue from a TEA perspective. Is this a sufficient concern/key performance indicator in the project? Will recycling/recovery be the main technical barrier? TEA assumption was 90%, but state of technology is at ~80%.

Wastewater treatment considerations need to be defined, validated, and tracked.

- The objectives of this project are not commensurate with the available resources; the project should refocus to demonstrate the viability of ionic liquids on a

model feedstock to define the technical and economic barriers to future commercialization. Based on my experience, the organic fraction of MSW is not cheap and very difficult to segregate. It is not suitable as a raw material for blending or large-scale production of biofuels.

- Is this a relevant project or an interesting science exercise which at this time has no commercial applicability? If the latter is the case is there a set of circumstances under which the project would be again commercially feasible? These are unanswered questions.
- Overall, the work is impressive and the reduced conversion times could potentially lower the capital cost for future facilities. I am not sure that the project belongs in FCIC, but rather in the Biological Conversion Technology Area. The project does need significant work in the separation and recovery of the ionic liquid—this work should be prioritized over the conversion of sugar to fuels (which is covered by other projects).
- This project, which is focused on improving feedstock preprocessing for downstream biochemical conversion, is unique in its focus on use of ionic liquids to improve sugar yields. The results clearly show an improvement in yield from use of ionic liquids (much more than blending) and scale-up results are also encouraging. However, there needs to be an honest cost/benefit analysis done to determine whether the improved yield justifies the added cost of ionic liquid use, which may be significant. Based on minimal cost data presented so far, it is not clear whether the BETO cost target can be achieved with this approach, and thus this goal should be closely monitored periodically to ensure that all future work has a reasonable chance at meeting the cost target.

¹⁷ Jian Sun, N. V. S. N. Murthy Konda, Jian Shi, Ramakrishnan Parthasarathi, Tanmoy Dutta, Feng Xu, Corinne D. Scown, et al., “CO₂ Enabled Process Integration for the Production of Cellulosic Ethanol Using Bionic Liquids,” *Energy and Environmental Science* 9 (2016): 2822–2834, doi:[10.1039/C6EE00913A](https://doi.org/10.1039/C6EE00913A); Feng Xu, Jian Sun, N. V. S. N. Murthy Konda, Jian Shi, Tanmoy Dutta, Corinne D. Scown, Blake A. Simmons, and Seema Singh, “Transforming Biomass Conversion with Ionic Liquids: Process Intensification and the Development of a High-Gravity, One-Pot Process for the Production of Cellulosic Ethanol,” *Energy and Environmental Science* 3 (2016): 1042–1049, doi:[10.1039/C5EE02940F](https://doi.org/10.1039/C5EE02940F).

PI Response to Reviewer Comments

- We thank all the reviewers for their comments.
- The wastewater treatment is being looked at and we have an initial life-cycle analysis draft currently under peer review. We have included TEA as part of the study in our recent peer-reviewed publications,¹⁷ which also looks into total solids loading, key industrial factors, and development of a high-gravity fed batch process. As we put our effort on ionic liquid screening for ionic liquids that can overcome the need of dilution and ionic liquid dehydration, the life-cycle analysis and TEA will be an integral part for that particular ionic liquid and processes. We thank the reviewer again for pointing out these important considerations—they are consistent with our drive and future directions.

We have refocused our efforts away from MSW and onto ionic liquid screening, recovery, process intensification, and comprehensive TEA. Early efforts on the project and success were critical to start to understand the commercial viability and identification of areas of improvements for this promising novel conversion technology.

The rapid advancement made in the development of low-cost ionic liquids and effectiveness of aqueous ionic liquids (very small ionic liquid amount needed) is overcoming the early, unfounded conclusions drawn by many. The ionic liquid technology is fairly new but very promising and should be pursued as currently there is no silver bullet technology that is deployable and viable for recalcitrant second-generation feedstocks utilization and enabling hefty goals of replacing petroleum fuels with biofuels.

We thank the reviewer for the thoughtful comments about the fit of the project in FCIC, and completely agree with the opinion. The project was part of biological conversion in previous years. In addition, I can also see several reasons this effort could also be part of FCIC (where feedstock heterogeneity and necessary preprocessing is a big challenge). Ionic liquid technology also has advantage on sugar to chemicals (in addition to fuel) and from lignin to chemicals. The ionic liquid technology provides a very clean stream of lignin and early results show depolymerization/conversion in the absence of expansive catalyst and these are all potential avenues to be explored in our years.

We are pleased with the reviewer's comments on sugar yields, "one pot" process development, process scale-up, and ionic liquids. These are some of the rapid advancement made on ionic liquid technology in such a short span (in comparison, dilute acid and ammonia-based processes are being looked at since early 1930s–1940s). We also agree with reviewer's comment on a detailed cost/benefit analysis. The current one-pot costs are indeed well above the BETO target for the methyl ketone production due to relatively low titers of the microbial production. For the ethanol case, our preliminary TEA and sensitivity analysis indicates the Minimum Ethanol Selling Price range of ~\$2.80-\$4.50. Therefore, our research effort in FY 2018 and beyond would be on neutral ionic liquid screening and lignin utilization. The success on this effort could be game changing for enabling the lignocellulosic biorefineries).

MIXED FEEDSTOCK CONVERSION SCREENING TO DEVELOP AND SCALE EFFICIENT INTEGRATED PROCESSING THROUGH PRODUCT TRANSFORMATION

(WBS#: 2.2.1.106 and 2.2.1.107)

Project Description

Commercial-scale biorefineries are designed to process 2,000 tons/day of single lignocellulosic biomass. Several geographical areas in the United States generate diverse feedstocks that, when combined, can be substantial for biobased manufacturing. Blending multiple feedstocks is a strategy being investigated to expand biobased manufacturing outside the Corn Belt. In this study, we developed a model to predict continuous envelopes of biomass blends that are optimal for a given pretreatment condition to achieve a predetermined sugar yield or vice versa. For example, our model predicted more than 60% glucose yield can be achieved by treating an equal part blend of

Recipient:	Lawrence Berkeley National Laboratory/Sandia National Laboratories
Principal Investigator:	Deepti Tanjore/Seema Singh
Project Dates:	10/1/2015–9/30/2016
Project Category:	Ongoing
Project Type:	AOP
DOE Funding FY 2014:	\$0
DOE Funding FY 2015:	\$255,000
DOE Funding FY 2016:	\$255,000
DOE Funding FY 2017:	\$255,000

energy cane, corn stover, and switchgrass at 10% solid loading with alkali at 120°C for 14.8 hours. By using ionic liquids to pretreat an equal part blend of the biomass feedstocks at 160°C for 2.2 hours, we achieved 87.6% glucose yield. Such a predictive model can potentially overcome dependence on a single feedstock, substantially lower feedstock costs, and reduce supply chain risks for a biorefinery. To assess the commercial applications of the model, we tested predictions from the model at higher

Weighted Project Score: 6.9

Weighting: For ongoing projects, there is equal weighting across all four evaluation criteria: Approach, Relevance, Accomplishments and Progress, and Future Work.

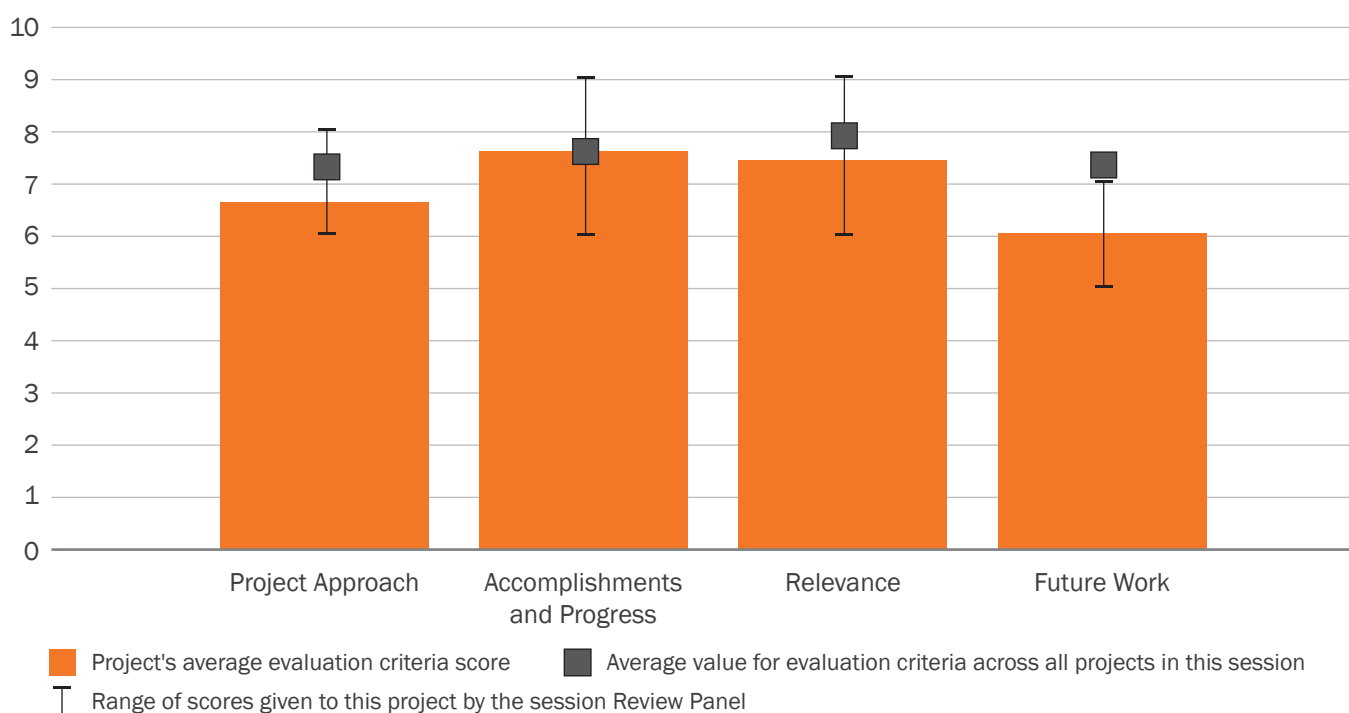

biomass loading of 30% weight by weight (w/w). Higher biomass loading led to half the sugar yields as those observed from lower loadings, but bore similar trends as predicted by the model. A blend of energy cane and switchgrass yielded at a lower shear stress (10 Pa) than energy cane itself (50 Pa). We observed 100% (of theoretical) ethanol yield from fermentation of biomass blend with only 20% corn stover. TEA provided a comprehensive understanding of the impact of biomass blends on biobased manufacturing.

Overall Impressions

- This is interesting work but is not well-informed by upstream variability in biomass and feedstocks. Results are not currently actionable because they need to incorporate biomass variability. I do commend the way the approach tries to incorporate upstream information from INL, but it is not yet doing it properly.
- It is not altogether clear if models produced at this tube/bomb scale are especially relevant as noted by the speaker. Laboratory scale should generally be used just for high-level screening, and then taken to pilot scale for creating valid models because significant differences in heat transfer, flowability, residence time distribution, solids loading, et al, can be simulated. Speaker made the comment that the pretreatment ranges were perhaps too narrow as time and temperature were insignificant in the model. Similarly, the ionic liquid yields did not vary enough to make for a strong model. I suggest adding an R² goal on the model with all insignificant variables removed while at the same time having method controls added.

An R₂ of 80% for a model is good but is largely coming from feedstocks, which hides the other variables. I suggest making mini models for each feedstock to understand the other variables.

If the project team finds the 20% corn stover blend relevant, they should consider adding mechanistic understanding as to why to their future work.

Acid pretreatment of mixtures led to furfural generation due to uneven severities for feedstocks with different recalcitrance. Excessive furfural indicates

the pretreatment laboratory protocol is potentially not in control. I would suggest doing some method/protocol validation with finer steps to quantify.

- This project creates the foundation and proves the concept for a future predictive model based on industrial data.
- This is a general comment for a variety of these activities focusing on the interaction between biomass types and blends and pretreatment. At this stage, the effort appears still a bit disjointed. The project has very interesting technical results, though it is based on highly idealized process conditions. In turn, the TEA is preliminary at best, and in most cases, there is not a precise analysis of risk factors. In general, scalability appears to be an afterthought if at all present. Lastly, it is not clear if these tools will allow only better planning for location of future IBRs or also better operations.

Overall, I still consider this interesting research. However, it would benefit from a concerted effort to focus it better.

- The rheology work is incredibly important, and could translate to useful learnings for industrial facilities in the near term. More focus there would place this work squarely within FCIC. The researchers did use a good experimental method that varies parameters resulting in good useful data on the rheology. I am not sure that the fermentation work is not duplicative from projects in the Biochemical Conversion Technology Area.
- This project is one of several in this session exploring various pretreatment effects on sugar production (via experiment and modeling) for biochemical conversion processes. The presentation of model results via triangular diagram with all key variable values highlighted is impressive. The rheological studies are also unique and important. It is not clear how blending tests, while important, differ from those in at least two other studies presented in this session,

which presents a concern of possible duplication of efforts. Seeing that this FCIC session is relatively new, BETO should verify all project scopes and revise as necessary so that all projects build constructively on each other's work.

PI Response to Reviewer Comments

We appreciate reviewer's concerns about the comprehensiveness of this project. With a limited budget, we attempted to study a broad research topic, and as such designed studies to primarily identify the most impactful variables. Scale-up work was an integral part of the proposal submitted in FY 2014. As a research unit placed in the PDU, scale-up is always in the forefront of several of our research projects, and never an afterthought. Scale-up of our predictions continues to be our intention. Due to the time limit of the Peer Review, we could not go into the details of the TEA efforts. The analysis was limited by a \$60K budget but was studied in detail. Our quarterly reports to BETO captured this detail with several risk factors considered.

We appreciate the reviewer's concern about possible overlap. While some of the efforts seem similar, the experiments were very different. In the future, we want to focus on the interface of feedstock conversion, e.g., fermentation of hydrolysates to a variety of biofuels including bisabolene and mixed ketones. This work coupled with rheological characterization will separate our efforts from those of other research teams in the BETO portfolio.

We echo the reviewer's comment on creating a foundation, a proof of concept, required to build a robust predictive model. We emphasize that the plan for FY 2017 and proposed future work are oriented toward developing a comprehensive predictive model applicable in an industrial setting.

To ensure relevance, in FY 2017, we will scale up predicted blends and deconstruction conditions to 100 L at 30% (w/w) biomass loading. In the future, we propose to develop a predictive model by performing all laboratory-scale alkali pretreatment studies at 30% (w/w) alone. This will allow us to create valid models for batch processing at the pilot scale. We propose to expand our rheological understanding of the blends to predict flowability issues, but the reviewer is accurate in pointing that we may not be able to estimate residence time in a continuous reactor. For this, we propose to work with an industry partner in FY 2019–FY 2020 to ensure that our model is applicable in real world scenarios.

We are now modeling data from each pretreatment catalyst individually. As such, ionic liquid data are not interfering with acid or alkali models. As our data set is limited, we were unable to further break it down based on feedstock. We will incorporate this suggestion into our future work, beyond FY 2018. Mechanistic modeling is also a part of the proposed future work. Our design of experiments, focused on extracting low- and high-sugar yields, led to some high severity acid pretreatments that may have caused furfural production. As mentioned in the accomplishments and progress section of our presentation, we will be performing only alkali pretreatments in the future and thereby furfural production will not be an issue.

Studying upstream variability seemed to be the most common suggestion from the Peer Review. We agree with the reviewers that this topic is most interest, when developing a model applicable in real world scenario. Accordingly, upstream variability in feedstocks is the factor of highest priority in developing our predictive model in the coming years.

FEEDSTOCK INTERFACE

(WBS#: 2.2.1.301, 2.2.1.304, and 2.2.1.305)

Project Description

Cost-competitive production of domestic biofuels on a national scale will require the conversion of low-cost and diverse biomass types, the impact of which on product yield and process efficiency is poorly understood. The joint Feedstock Interface project between National Renewable Energy Laboratory/Idaho National Laboratory/Pacific Northwest National Laboratory seeks to understand the process and economic impacts of variable biomass resources in thermochemical processes (i.e., fast pyrolysis, hydrothermal liquefaction, catalytic fast pyrolysis, gasification, and hydrotreating). We are testing commercially-relevant feedstocks at the bench scale with a near-term goal of establishing in-feed specifications that ensure BETO’s conversion cost targets (e.g., \$2.53/gasoline gallon equivalent for pyrolysis/hydrotreating) are met using an \$84/dry ton blended

Recipient:	Idaho National Laboratory/ National Renewable Energy Laboratory/ Pacific Northwest National Laboratory
Principal Investigator:	Tyler Westover/Dan Carpenter/Dan Howe
Project Dates:	10/1/2015–9/30/2018
Project Category:	Ongoing
Project Type:	AOP
DOE Funding FY 2014:	\$1,200,000
DOE Funding FY 2015:	\$3,335,000
DOE Funding FY 2016:	\$2,465,000
DOE Funding FY 2017:	\$2,465,000

feedstock. Among this project’s key recent achievements was confirming that a low-cost blend can meet conversion targets, reducing the modeled fuel production cost by 7% (\$0.24/gasoline gallon equivalent), and the development of a model to predict pyrolysis oil yield based on feedstock composition. Our work shows that feedstock impacts multiple parts of the process, including pyrolysis oil yield/composition, hydrotreating yield,

Weighted Project Score: 7.4

Weighting: For ongoing projects, there is equal weighting across all four evaluation criteria: Approach, Relevance, Accomplishments and Progress, and Future Work.

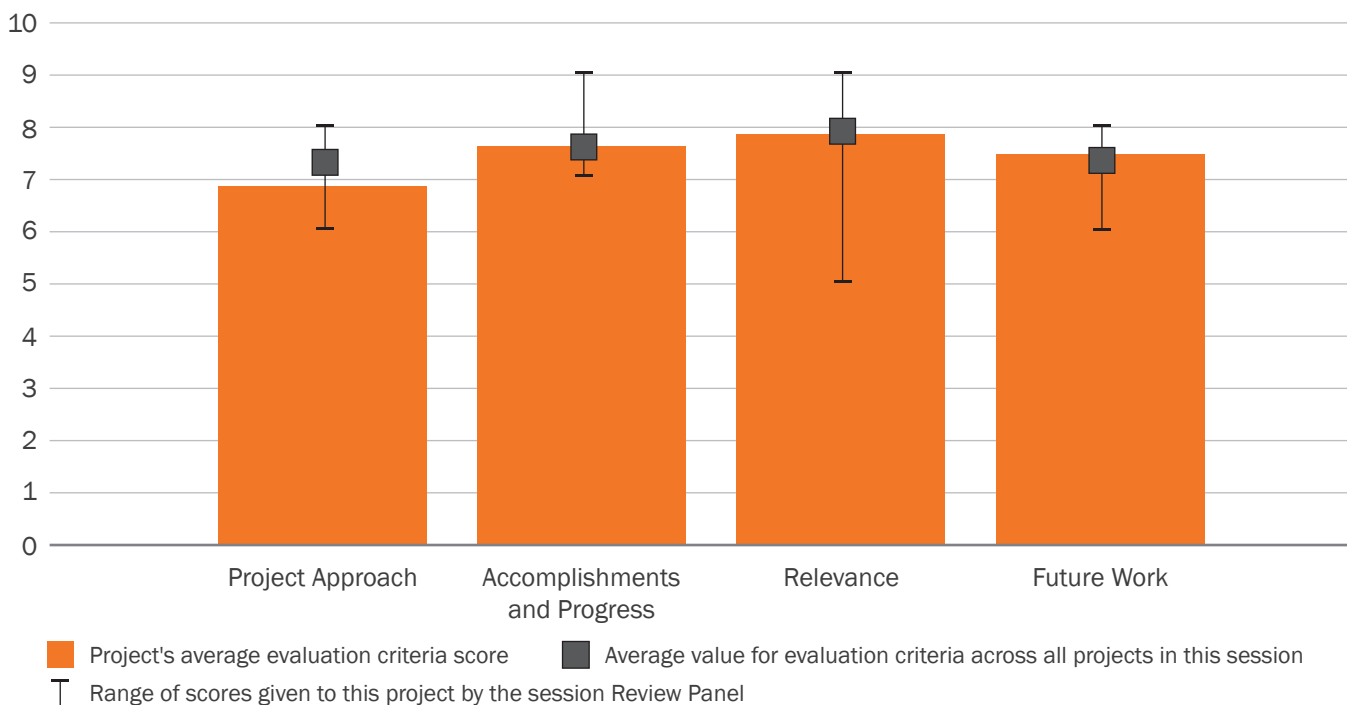



hydrogen consumption, selectivity to fuel products, and can result in a 40% variation in final biofuel cost. By quantifying these impacts, this project provides insight into the financial risks of various conversion approaches with respect to feedstock, enabling more flexible and market-responsive technologies.

Overall Impressions

- Generally, this is a useful project and a first step to enable assessment of field to fuel. It is nice to finally see this happen. However, it is still not particularly realistic in assessment of non-pristine feedstocks, and the statistical model developed is likely not capable of capturing the variability of all factors assessed, and therefore probably doesn't accurately predict "winners." The project team needs to use different methods to assess and incorporate variability (e.g., Bayesian approaches) and identify places where future effort should focus.
- Why pilot after the modeling step? This isn't a typical way to do it with the relatively significant

impact of scale. Consider some piloting earlier in the project.

I would like to see some thoughts about where variation comes from between the field and the reactor throat? Impact of pelleting and others in the future plans may need considered. Aging impacts on the blending quality could be significant.

Relevance: The plan is to do other thermochemical treatments—is this particularly value adding versus other downstream tests? Can the variation on the optimal blend be good enough for all? Broad success ranges would be easier to rollout broadly.

- Overall the quality of the work is adequate and it is moving toward the achievement of its stated goals. The project does not adequately address the feedstock interface questions and it assumes that a blended feedstock will help the achievement of the cost objective. The optimization tool should help the nth-of-a-kind facility, but it is unlikely to answer the needs of the first of a kind facilities.
- I have very mixed feeling about this project. The blending of feedstocks and the understanding of blend properties is going to be of significant importance. However, as the proposed reference technologies haven't been credibly proven at any scale, I struggled on whether this is a relevant project at this stage. The work on ash removal and control is an important redeeming quality.
- It appears that the project is doing a good job of addressing the BETO goals from a few years ago, but it may be prudent for a minor adjustment to focus more on the feedstock interface for the new FCIC area. Product yield and cost reductions due to blending are more medium- or long-term issues, where blending for optimization or ease of processing may fit the current needs better. The project is an impressive blend of different laboratories and complementary capabilities.

- The concept behind this project, which focuses on addressing feedstock variability effects on thermochemical conversion processes, is an important contribution to process optimization. By concentrating on the effects of blending of pure feedstocks, this project represents a good start. However, other feedstock aspects that impact variability and thus product yield (e.g., ash content, feedstock local and seasonal quality, and impurities) need to also be considered in order for the full value of this project to be realized.

PI Response to Reviewer Comments

- We appreciate the reviewers' concerns over capturing variability across the supply chain. This project started with testing a wide variety of potential feedstocks with the intent of capturing a large range of performances and developing robust models with respect to feed composition. Future work will hone in on key thermochemical conversion feedstocks including forest residues, pulpwood, and sorted construction and demolition wastes to determine the impacts of preprocessing on conversion performance at different scales. Ultimately, the objective is to correlate conversion performance to feedstock attributes rather than type or cultivar. The type of feedstock for each test in this work is provided only as a means to identify the particular test and is not intended to represent the wide range of properties and attributes that can be found in every feedstock type.

Regarding the modeling efforts, the statistical regression fits used to date have identified strong correlations between feedstock attributes and conversion parameters, but we acknowledge the more

complex effects will require more advanced modeling. We will pursue these types of approaches in coming years. Bayesian and other similar statistical approaches to understand the impact of feedstock variability will require knowledge of the distributions of the key feedstock attributes, both in the raw biomass and in the preprocessing operations. Those data are being generated within BETO and will be incorporated into this project as they become available.

We agree that there are challenges presented by evaluating feedstocks in conversion processes that are rapidly developing, and there will likely be additional challenges during scale up. However, as a de-risking strategy, we feel that there is value in identifying potential feedstock-related issues early on that can help avoid these scale-up problems (e.g., dealing with contaminants or catalyst poisons by hot filtration). We understand the importance of assessing feedstock performance at multiple scales. Bench- and pilot-scale efforts are being pursued simultaneously, although the pilot facilities were only recently brought online for long-term testing.

Future efforts will focus on determining the impact of feedstock attributes on the ease of processing at pilot scale and the ability to control variability sufficiently in both raw materials and preprocessing operations such that feedstocks are reactor-ready (i.e., they meet conversion specifications, which this project assists in establishing). Based on comments from the project reviewers and new directions within FCIC, the focus on blends is being somewhat deemphasized to allow more focus on the impacts of feedstock attributes within a smaller range of high-impact feedstocks.

FEEDSTOCK CHARACTERIZATION, PERFORMANCE, AND DEVELOPMENT

(WBS#: 2.2.1.501)

Project Description

The first-of-a-kind cellulosic ethanol demonstration plants have been struggling with feedstock variability. Performance, processing, and operations are significantly affected by the quality variation and the presence of contaminants in the biomass materials that are fed into these units. This clearly indicates that not every biomass material is a feedstock. This project tries to map the biomass resources to potential conversion pathways, maximizing their incorporation into the bioeconomy. Our approach is to define and implement a conversion-based biomass grading system founded on key biomass characteristics selected from the comprehensive characterization of more than 150 commercially relevant

Recipient:	Idaho National Laboratory
Principal Investigator:	Magdalena Ramirez
Project Dates:	10/1/2005-9/30/2018
Project Category:	Ongoing
Project Type:	AOP
DOE Funding FY 2014:	\$630,000
DOE Funding FY 2015:	\$0
DOE Funding FY 2016:	\$1,940,000
DOE Funding FY 2017:	\$1,940,000

samples. The selected characteristics are those that most affect conversion to fuels. The ranges of variation of these key properties have to be determined to define the corresponding grades. This simple three-step approach includes a binning methodology and an extensive network of collaborators and partners to facilitate the solution of such a complex problem. A framework has been already defined that provides economic and technical rationale for the quality grades and establishes the basic principles for grading. It is expected that grading not only will set the price scale for the supply side and the

Weighted Project Score: 7.2

Weighting: For ongoing projects, there is equal weighting across all four evaluation criteria: Approach, Relevance, Accomplishments and Progress, and Future Work.

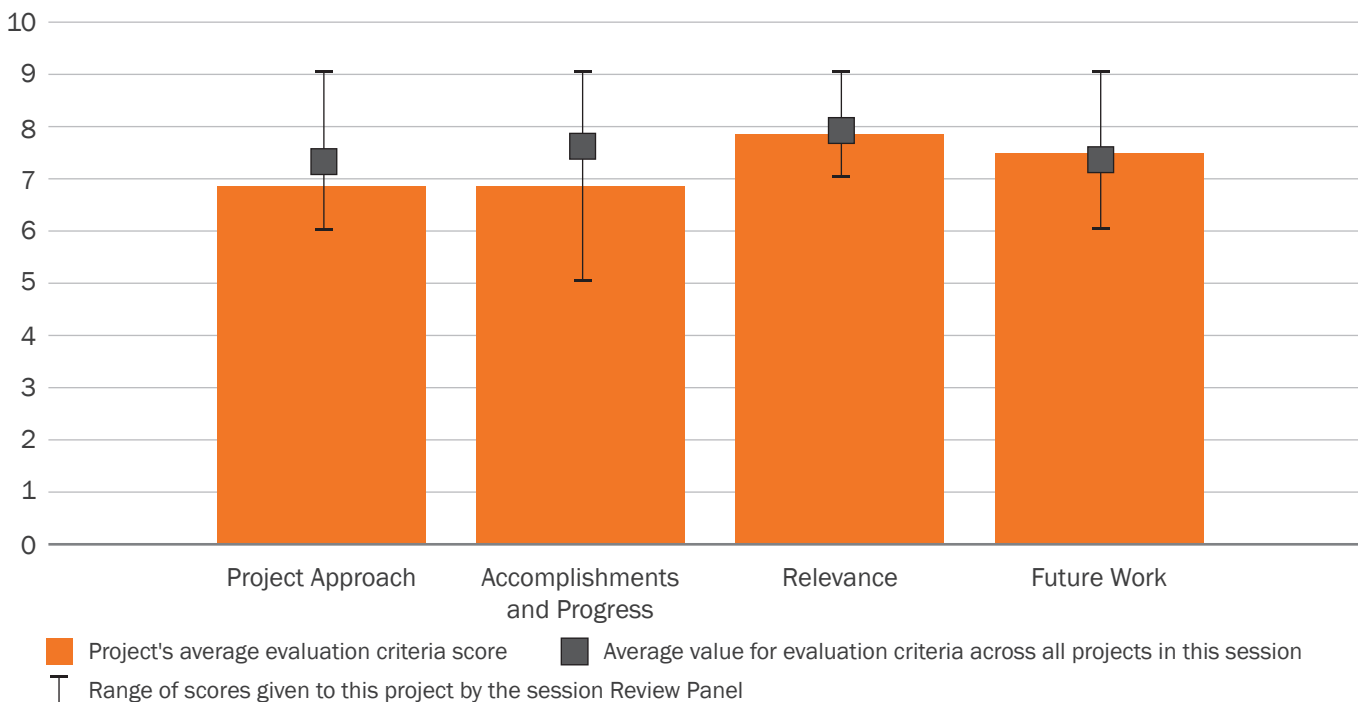
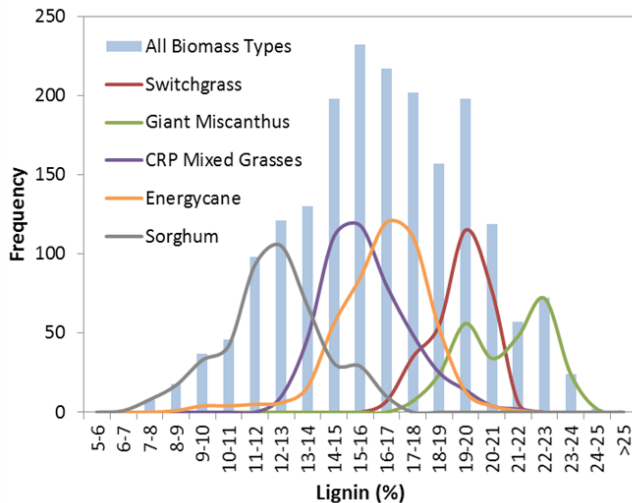

Photo Courtesy of Idaho National Laboratories



preprocessing needs for the demand side, but also will allow the incorporation of low cost and/or low-quality resources into the bioeconomy.

Overall Impressions

- This is a useful project and foundational to the industry. It needs to tie into the existing biomass grading systems so it is possible to translate between industries. For example, how does a thermochemical grade here relate to a grade in the heat and power industry? The team is aware and is looking forward to involvement of advisory board to guide future work and deployment.
- Same comments for other projects. The effort has merit but is a bit confused.
- A standard grading system could increase the deployment rate of biomass energy projects by establishing biomass as a tradable commodity. It would be particularly useful for future purpose grown crops and would help farmers select the most valuable strains to plant. A commodity system for agricultural waste that focuses on items that the farmer/harvester can control such as moisture or ash content could be very useful.
- The concept behind this project, which is focused on establishing a grading system for feedstocks

based on measurements of key properties, is good and would be a helpful tool. If successful, a grading system has the potential to more fairly assess cost and balance and the need for any necessary preprocessing. However, any grading system developed has to be sufficiently comprehensive to accurately classify wide varieties of feedstock types, but at the same time be simple to implement and use, which is no easy task. Until all the metrics are fully identified and bin ranges established, it is not clear if the proposed approach will be successful. Furthermore, a bigger potential challenge is getting buy-in from the feedstock supplier community where there is potential for lost revenue from lower quality stock under the new grading system that previously would have been sold at the same price. Finding a way to involve these stakeholders in this project is critical to its future implementation.

- The project is a good idea that could benefit from the biomass suppliers and the industry users to focus on the present needs of the industry.
- What sort of timeline for the grading implementation is targeted to be able to help support the Co-optima? The speaker stated that the existing INL information is likely already available to start rollout.

How does the project anticipate the grading will influence the feedstock cost and therefore the general rollout of the industry? The presenter anticipates the project will allow for low-cost and/or low-quality resources.

How will storage losses/quality changes be managed in the grading system? Due to the combustion application where high lignin fetches higher value/price, a given feedstock “batch” will likely have a somewhat dynamic valuation. The presenter discussed a need to create models to simulate the storage changes on the value versus reanalyzing batches.

This is a good project providing a necessary tool to the industry.

PI Response to Reviewer Comments

- Direct translation among different industrial interests may be difficult if not impossible. For instance, translating fuel oil grades into coal grades would be difficult, and both are used by the same end user (energy generation via combustion). Nevertheless, the forecast from companion markets and the advice of the FCIC Industry Advisory Board will be used to keep on the right track.

Not all grading properties have been selected. The grading properties would ideally be intrinsic characteristics of the biomass and the penalties would be under farmer/harvester control. In this way, best practices will be promoted. Hopefully, the number of grades can be minimized. Our goal is to define a small number of technically (and economically) meaningful bins. It is understood that ash and moisture are important parameters in a grading system for biofuels. The main problem with ash incorporation in the grading system at this time is lack of availability of analytical tools that can easily discriminate between soil contamination (caused mainly by harvesting technique) and inorganic nutrients in the biomass itself (e.g., affected by climate, soil, or fertilizers). The project interacts with another project that is developing methodologies to discriminate between these two measurements. Once these techniques become available the mode of incorporation into the grading system can be defined. The effects of moisture certainly go beyond degradation, which was cited in the presentation as an example. Moisture affects different preprocessing techniques as well as conversion processes. We are working with INL projects that have already collected some

information regarding the impacts of moisture and ash and their potential cost in addition to the Bio-energy Library where much of this characterization information is stored.

We agree with the reviewer that it will be a challenge getting buy-in from the feedstock supplier community where there is potential for lost revenue from lower quality. It is difficult to keep the vendor and the buyer happy on only economic grounds. Finding the win/win balance between the supply and demand sides is the determinant. Involvement of industrial stakeholders on each side will mitigate implementation risks.

Focusing on the present needs of industry will start in FY 2018 by working with the FCIC Industry Advisory Board.

We envision a closer industrial involvement in the immediate future, particularly to ensure the consistency checking exercise and to minimize industrial concerns during the future rollout. The timing for the rollout is yet to be determined and will be influenced by these efforts.

The development of the grading system requires large efforts in characterization work. The resulting characterization data and identification of a small number of properties that have the most impact on conversion can be used to focus on the most meaningful preprocessing, allowing for a more cost-effective approach. Hopefully, low-cost and/or low-quality resources could be incorporated with less technical risk.

The definition of penalties (dockage) or rewards is part of the scope for the remainder of FY 2017 and FY 2018, and will be included as part of a preliminary grading system. This scope will include working with analysis and feedstock projects at INL.

PRETREATMENT AND PROCESS HYDROLYSIS—PRETREATMENT

(WBS#: 2.2.3.100)

Project Description

The Pretreatment and Process Hydrolysis project develops scalable lower severity deconstruction/fractionation processes that produce low cost, low toxicity, high concentration sugar syrups and tractable, reactive lignin streams at low enzyme loadings using relevant advanced blended and formatted feedstocks in collaboration with FCIC and INL for the biological and catalytic upgrading to hydrocarbon fuel precursors. Enzymatic hydrolysis reactions with deacetylation/mechanical refining (DMR) corn stover substrates at 32 weight percent (wt%) insoluble solids achieved 270 g/L fermentable monomeric sugars at >80% yields (with up to 10% oligomers) that are fermentable to 86 g/L at >90% process yields with a co-fermenting *Zymomonas* strain, demonstrating the low toxicity of the syrups. Rheology studies showed the

Recipient:	National Renewable Energy Laboratory
Principal Investigator:	Melvin Tucker
Project Dates:	1/30/2003–9/30/2018
Project Category:	Ongoing
Project Type:	AOP
DOE Funding FY 2014:	\$800,000
DOE Funding FY 2015:	\$1,400,000
DOE Funding FY 2016:	\$1,400,000
DOE Funding FY 2017:	\$1,400,000

hydrolysate was pumpable at 60 h. Batch-wise counter-current recycle of deacetylation black liquor showed minimal effects on deacetylation, enzymatic hydrolysis, and fermentation performances, with TEA showing a decrease in water and energy usage and decreased fuel selling price. Blended feedstocks were found to be more recalcitrant, with enzymatic hydrolysis yields of 80% monomeric sugars achieved with deacetylation/dilute acid (DDA) and DMR. In the future we are investigating continuous deacetylation, testing advanced blended and formatted tri- and quad-blended feedstock performance

Weighted Project Score: 8.0

Weighting: For ongoing projects, there is equal weighting across all four evaluation criteria: Approach, Relevance, Accomplishments and Progress, and Future Work.

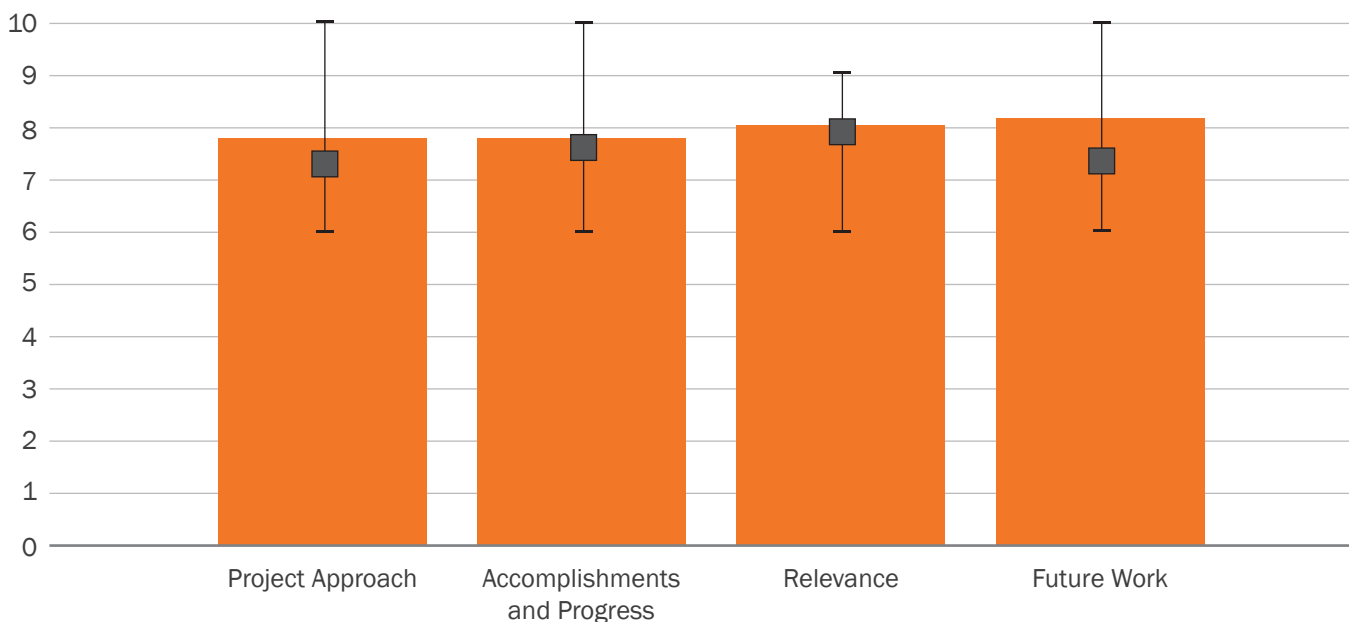

■ Project's average evaluation criteria score
 ■ Average value for evaluation criteria across all projects in this session
 Range of scores given to this project by the session Review Panel

in DDA and DMR, and a microbial electrochemical technology to recycle the sodium hydroxide without the use of an expensive recovery boiler/lime kiln.

Overall Impressions

- This is an excellent project with far reaching significance.
- This project has an innovative approach to lower the severity of the pretreatment process.
- I ended up being a bit confused by the project as the author tried to cram too much into it and failed to provide a clear pathway to scalability focusing on a few critical issues. Overall the technical results are interesting, but the TEA is not well spelled out. Because of it, it is difficult to assess the real prospect of this project for commercial viability and under which conditions.
- The researchers have an interesting process focused on underutilized/abandoned pulp and paper assets. This project may be better suited for the Biochemical Conversion Technology Area, as it is a full process and not an agnostic pretreatment process that could be utilized with a number of existing processes.
- This project, which focuses on developing chemical and mechanical pretreatment steps for separating lignin and increasing sugar yield from biomass, is unique and important work. If successful, these pretreatment steps may help improve the feedstock quality for downstream bioconversion processes and thereby lower the fuel or bioproduct cost closer to or below the target value. The results from several investigations in this project are encouraging. However, it is not entirely clear how all of the individual tests and results described fit together to achieve the overall goal. A more systematic study of the effects of key variables on sugar yield and/or lignin separation (if not already done or planned) would be good

to consider, as well as a comparison of the overall cost of the full production process with pretreatment steps relative to baseline to know the true value of any proposed improvements.

PI Response to Reviewer Comments

- We thank all of the reviewers for their insightful comments.

This project collaborates very closely with other Biochemical Conversion projects and INL, concentrating on DDA pretreatments and DMR deconstruction/fractionation processes performed in parallel on aliquots of the same deacetylated individual and blended feedstocks, with results incorporated into TEA analysis for direct comparisons. The TEA analyses were performed by key personnel from the Biochemical Platform Analysis project to maintain consistency with the methods and assumptions within the NREL TEA models. Thus, DDA pretreatments were used as baselines for comparison to DMR.

Dilute alkali (0.1 to 0.3 molar sodium hydroxide) deacetylation is retained for both processes because up to 30 wt% (or more) of the incoming biomass is solubilized in the unit operation, substantially decreasing downstream equipment sizes, thus saving capital and operating expenses. The DMR process was shown here to be as robust as DDA pretreatments on corn stover harvested in multiple years from various parts of the country, switchgrass, sorghum and other herbaceous crops. In contrast to DDA, the low toxicity, high concentration sugar syrups, and reactive lignin streams significantly enhance downstream biological and catalytic upgrading of these streams, where the DMR sugar streams allowed fermentations to intermediates (i.e., lipids or 2,3-butanediol) with high titers, rates, and productivities similar to pure sugar controls as presented in other project reviews within Biochemical Conversion sessions.

The lignin streams from DMR have been shown to be biologically and catalytically upgradable to bioproducts and bio-jet blendstocks by a number of peer-reviewed publications and work presented in other project reviews within the Biochemical Conversion sessions. We showed the progression of DMR research from 2014 through 2018 and beyond, starting with bench-scale work and low solids enzymatic hydrolysis then addressing critical issues such as efficacy on feedstock blends and increasing insoluble solids concentrations in enzymatic hydrolysis (up to 33 wt% and 270 g/L monomeric sugar concentrations) while maintaining high yields at low-enzyme loadings using DMR substrates. We are investigating higher solids loadings. In contrast, we found DDA pretreated substrates reached a maximum of ~150 g/L monomeric sugar concentrations in enzymatic hydrolysis, and the hydrolysates were more toxic.

All of the DMR results presented here were obtained using a pilot-scale 36-inch disc refiner (at measured 20 to 36 dry ton/day throughputs) that can be directly scaled to larger 54- and 60-inch refiners of 700 dry tons/day throughputs. Because DMR provides an opportunity for a simpler, atmospheric pressure deconstruction process and uses equipment

well known in commercial industries that could help resolve feedstock management and feeding issues being encountered commercially in the pioneer biorefineries, thus it could be considered to be highly relevant to the feedstock interface problem.

Due to the time constraints, an in-depth discussion of all the assumptions in the three TEA analyses presented was not possible. These assumptions were described by Ryan Davis in his talk for the Biochemical Platform Analysis Project in the Biochemical Conversion session.

We have tested several key variables in DMR such as sodium hydroxide concentrations/loadings, temperature, residence times, refiner plate gaps, refiner feed rates, solids concentrations entering the refining step, refining energy, and solids and enzyme loadings in high solids enzymatic digestions, etc. on sugar yields, lignin separation, lignin quality (e.g., degree of polymerization, β -O-4 linkages, molecular weight, and catalytic/biological upgradability), all of which were compared in parallel directly with DDA pretreatment results using aliquots of the same deacetylated feedstocks. The DDA pretreatment results (including fermentations) were used as the baselines for the TEA comparisons presented.

ADVANCED ALGAL SYSTEMS



TECHNOLOGY AREA



CONTENTS

INTRODUCTION.....	115
ADVANCED ALGAL SYSTEMS OVERVIEW.....	115
ADVANCED ALGAL SYSTEMS REVIEW PANEL.....	116
TECHNOLOGY AREA SCORE RESULTS.....	117
ADVANCED ALGAL SYSTEMS REVIEW PANEL SUMMARY REPORT.....	118
ADVANCED ALGAL SYSTEMS PROGRAMMATIC RESPONSE	122
MICROALGAE ANALYSI	124
ALGAE POLY CULTURE CONVERSION AND ANALYSIS.....	127
ALGAL BIOFUELS TECHNO-ECONOMIC ANALYSIS	129
ALGAE TECHNOLOGY EDUCATIONAL CONSORTIUM.....	131
SUSTAINABLE DEVELOPMENT OF ALGAE FOR BIOFUEL.....	134
FUNCTIONAL CHARACTERIZATION OF CELLULAR METABOLISM.....	137
MULTI-SCALE CHARACTERIZATION OF IMPROVED ALGAE STRAINS	140
ALGAE BIOTECHNOLOGY PARTNERSHIP.....	142
BREEDING ALGAE FOR LONG-TERM STABILITY AND ENHANCED BIOFUEL PRODUCTION.....	144
MAJOR NUTRIENT RECYCLING FOR SUSTAINED ALGAL PRODUCTION.....	146
INTEGRATION OF NUTRIENT AND WATER RECYCLING FOR SUSTAINABLE ALGAL BIOREFINERIES.....	148
CONTINUOUS BIOLOGICAL PROTECTION AND CONTROL OF ALGAL POND PRODUCTIVITY	151
INTEGRATED PEST MANAGEMENT FOR EARLY DETECTION ALGAL CROP PRODUCTION	153
ALGAE PRODUCTION CO ₂ ABSORBER WITH IMMOBILIZED CARBONIC ANHYDRASE	155
ATMOSPHERIC CO ₂ CAPTURE AND MEMBRANE DELIVERY.....	157
ALGAE DISCOVER PROJECT: DEVELOPMENT OF INTEGRATED SCREENING, CULTIVAR OPTIMIZATION, AND VALIDATION RESEARCH	160
GENETIC BLUEPRINT OF MICROALGAE CARBON PRODUCTIVITY	163
THE GREENHOUSE: A COMPREHENSIVE KNOWLEDGE BASE OF ALGAL FEEDSTOCKS	166
MICROALGAE BIOFUELS PRODUCTION ON CO ₂ FROM AIR.....	168
DIRECT PHOTOSYNTHETIC PRODUCTION OF BIODIESEL BY GROWTH-DECOUPLED CYANOBACTERIA.....	170
A NOVEL PLATFORM FOR ALGAL BIOMASS PRODUCTION USING CELLULOSIC MIXTROPHY	173
ALGAL FEEDSTOCKS LOGISTICS AND HANDLING	176
THERMOCHEMICAL INTERFACE	179
BIOCONVERSION OF ALGAL CARBOHYDRATES AND PROTEINS TO FUELS	181
ALGAL BIOMASS CONVERSION	183
ALGAL BIOMASS VALORIZATION.....	186
PRODUCING TRANSPORTATION FUELS VIA PHOTOSYNTHETICALLY DERIVED ETHYLENE	188

ALGAE TESTBED PUBLIC-PRIVATE PARTNERSHIP (ATP3)	191
REGIONAL ALGAL FEEDSTOCK TESTBED (RAFT) PARTNERSHIP	194
DEVELOPMENT OF ALGAL BIOMASS YIELD IMPROVEMENTS IN AN INTEGRATED PROCESS – PHASE II	196
BIOMASS PRODUCTIVITY TECHNOLOGY ADVANCEMENT TOWARDS A COMMERCIALY VIABLE, INTEGRATED ALGAL BIOMASS PRODUCTION UNIT	198
REALIZATION OF ALGAE POTENTIAL (REAP)	200
SCALE-UP OF ALGAL BIOFUEL PRODUCTION USING WASTE NUTRIENTS.....	203
INTEGRATED LOW-COST AND HIGH-YIELD MICROALGA BIOFUEL INTERMEDIATES PRODUCTION	206
ADVANCING COMMERCIALIZATION OF ALGAL BIOFUELS THROUGH INCREASED BIOMASS PRODUCTIVITY AND TECHNICAL INTEGRATION.....	209
DEVELOPMENT OF ALGAL BIOMASS YIELD IMPROVEMENTS IN AN INTEGRATED PROCESS – PHASE I	211
PRODUCTION OF BIOCRUDE IN AN ADVANCED PHOTOBIOREACTOR-BASED BIOREFINERY	213
PRODUCING ALGAE FOR CO-PRODUCTS AND ENERGY (PACE)	216
MARINE ALGAE INDUSTRIALIZATION CONSORTIUM (MAGIC): COMBINING BIOFUELS AND HIGH-VALUE BIOPRODUCTS TO MEET RFS	219

INTRODUCTION

Six external experts from industry, academia, and other government agencies reviewed a total of 39 projects during the Advanced Algal Systems session. This review addressed a total U.S. Department of Energy (DOE) investment of approximately \$115,631,328, which represents approximately 16% of the Bioenergy Technologies Office (BETO) portfolio reviewed during the 2017 Project Peer Review. During the Project Peer Review meeting, the principal investigator (PI) for each project had 30 minutes to deliver a presentation and respond to questions from the Review Panel.

Reviewers evaluated and scored projects for their approach, technical progress and accomplishments, relevance to BETO goals, and future plans. This section

of the report contains the results of the Project Review, including full scoring information for each project, summary comments from each reviewer, and any public response provided by the PI. This section also includes overview information on the Advanced Algal Systems Program, full scoring results and analysis, the Review Panel Summary Report, and the BETO Programmatic Response.

BETO designated Daniel Fishman, Technology Manager, as the Advanced Algal Systems Review Lead. In this capacity, Mr. Fishman was responsible for all aspects of review planning and implementation. Lead Reviewer, Dr. Eric Jarvis, prepared the Advanced Algal Systems Review Panel Summary Report with support and contribution from the entire Review Panel.

ADVANCED ALGAL SYSTEMS OVERVIEW

The role of the Advanced Algal Systems Program is to fund the research and development (R&D) of sustainable algae production, logistics, and conversion to biofuels. Projects within the portfolio address a diverse range of topics, including algal biology; algal cultivation, harvest, and processing logistics; conversion interfaces and conversion technologies; and analyses of high-value co-products, techno-economics, sustainability, and resource availability.

Advanced Algal Systems R&D focuses on demonstrating progress toward achieving high-yield, low-cost, environmentally sustainable algal biomass production and logistics systems that produce algal feedstocks well suited for conversion to fuels and other valuable products. Algal biomass includes micro- and macro-algae, as well as cyanobacteria. Algal feedstocks include concentrated whole algae biomass, fermentable substrates, extractable lipids, secreted metabolites (alcohols or others), or biocrude resulting from hydrothermal liquefaction

(HTL). These feedstocks must be upgraded, blended, and/or purified to produce a finished fuel or bioproduct. Developing algal feedstocks to achieve BETO's advanced biofuel price goals requires breakthroughs along the entire algal biomass supply chain.

Advanced Algal Systems Support of Office Strategic Goals

The strategic goal of Advanced Algal Systems R&D is to develop algae production and logistics technologies that, if scaled up and deployed, could support the production of 5 billion gallons per year of sustainable, reliable, and affordable algae-based advanced biofuels by 2030. The strategic goal directly addresses and supports production of algal feedstocks for use by all potential conversion pathways to both biofuels and bioproducts.

Advanced Algal Systems Support of Office Performance Goals

The Advanced Algal Systems performance goal is to increase the projected productivity of large-scale algae

cultivation and preprocessing while maximizing efficiency of water, land, nutrient, and power use to supply a stable biofuel intermediate for conversion to advanced biofuels. Specifically, the program will validate the potential for algae supply and logistics systems to produce 5,000 gallons of oil (or an equivalent biofuel intermediate) per acre of cultivation per year at the pre-pilot scale by 2022; this will achieve a modeled nth plant minimum selling price of \$3.00/gasoline gallon equivalent (gge) of algal biofuel. For details on the technology area goals, please review BETO’s 2016 *Multi-Year Program Plan* (MYPP).

Advanced Algal Systems Approach for Overcoming Challenges

The Advanced Algal Systems approach for overcoming challenges and barriers is outlined in its work breakdown structure (WBS), organized around five key activities. Current activities are focused on (1) assessing current and potential sustainable biomass feedstock resources and corresponding costs; (2) developing improved algal strains and sustainable feedstock cultivation systems; (3) improving the capacity and efficiency of harvesting, preprocessing, storage, and handling; (4) characterizing algae to interface appropriately with conversion methods; and (5) scaling integrated algae R&D systems. These activities are performed by national laboratories, universities, industry, consortia, and a variety of state and regional partners.

ADVANCED ALGAL SYSTEMS REVIEW PANEL

The following external experts served as reviewers for the Advanced Algal Systems Program during the 2017 Project Peer Review.

Name	Affiliation
Eric Jarvis*	Independent Consultant
Toby Ahrens	U.S. Department of Agriculture, National Institute of Food and Agriculture
Louis Brown	Synthetic Genomics
Bill Crump	Leidos
Sarah Smith	A.E. Allen Laboratory, Scripps Institution of Oceanography
Rebecca White	Qualitas Health

* Lead Reviewer

TECHNOLOGY AREA SCORE RESULTS

Average Weighted Scores by Project

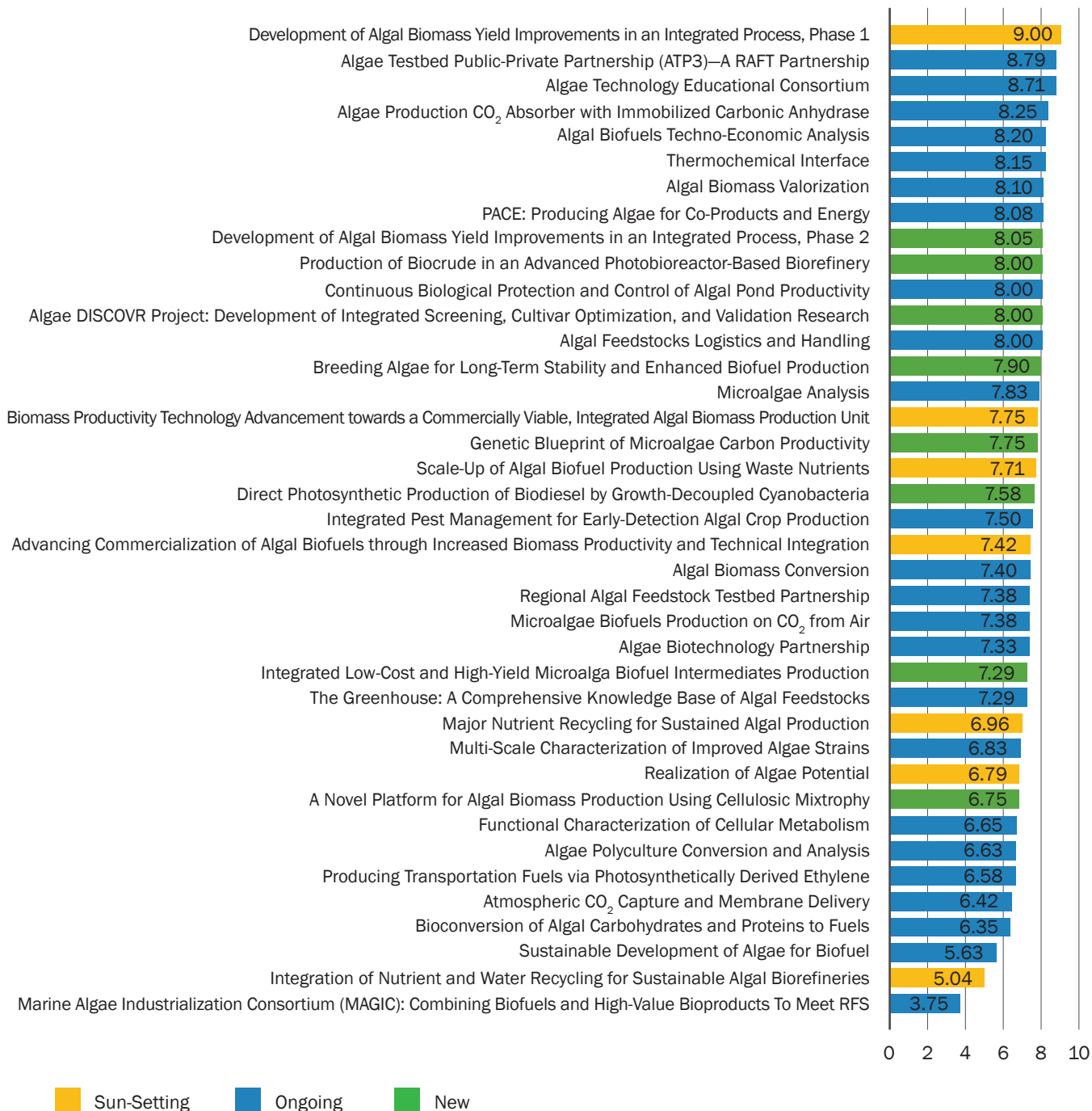

ADVANCED ALGAL SYSTEMS REVIEW PANEL SUMMARY REPORT

Prepared by the Advanced Algal Systems Review Panel

Overall, the projects within Advanced Algal Systems have demonstrated excellent productivity over the past 2 years. The projects are well aligned with the goals of BETO's MYPP and show a high degree of diversity, touching on all of the critical technology barriers. High levels of innovation are evident in many of the projects, and there is an excellent balance between lower-risk, incremental reward and higher-risk, potentially transformational approaches.

BETO has effectively molded the research directions of the ongoing projects through the guidance of multiple funding opportunity announcements (FOAs). This has led to significant changes in emphasis since the last review, including a focus on marine strains, increased attention to co-products, and novel approaches for atmospheric carbon dioxide (CO₂) utilization. An across-the-board emphasis on reaching productivity targets is evident.

The three top-scoring projects reflect the overall diversity of the portfolio:

- The first of three presentations by Global Algae Innovations Inc. (GAI) outlined its Advancements in Algal Biomass Yield (ABY1) project, which targeted improved strains, cultivation, and novel harvest/dewatering technology to demonstrate an integrated process at large scale. The work was tightly linked to GAI's cost models and demonstrated significant progress toward BETO goals in terms of biofuel intermediate yield and reductions in preprocessing energy. Specific outcomes include commercialization of the Zobi Harvester[®] dewatering system and claims of a modeled \$3.33/gge minimum fuel selling price (MFSP) for GAI's integrated process.
- The Algae Testbed Public-Private Partnership (ATP3) stood out as an outstanding resource for the

entire community. The team has served many stakeholders and provided high-quality, multi-regional, long-term growth data to establish the BETO state of technology (SOT). Methods development, standardization, and harmonization have been critical. ATP3 is one of several foundational projects that support the program, including the National Renewable Energy Laboratory's (NREL's) Algal Biofuels Techno-Economic Analysis and Algal Biomass Valorization and Pacific Northwest National Laboratory's (PNNL's) Microalgae Analysis projects.

- The Algae Technology Educational Consortium run jointly by NREL and University of Southern Maine scored highly as filling an important role for the algal biotechnology industry. By working to establish degree programs and coursework through academic partners, the project has already made progress toward satisfying industry's need for trained workers.

The Advanced Algal Systems Program is on track. Over the coming years, it will be critical to maintain momentum, particularly in productivity improvements and identification of viable co-products. Improvements in agronomic practices at scale and strengthening of connections between researchers and industry will also be critical for establishing a viable algal biofuels industry.

Impact

The projects BETO is funding are clearly advancing the SOT, and future work planned should continue to move the industry toward BETO's targets. Extensive work has been completed over the past 2 years to solidify the current SOT, both through ATP3's long-term productivity data and through NREL's in-depth techno-economic analyses (TEAs). The unavoidable conclusion from this work is that achieving \$/gge MFSP targets will require significant advances across the entire value chain and must include valorization of other components (i.e., co-products). Private-sector investment cannot yet substitute for government funding because of the degree of risk that must still be overcome to achieve cost-ef-

fective algal fuel production. For the foreseeable future, it is appropriate for BETO to continue funding projects at a variety of technology readiness levels all the way through large-scale, pre-commercial deployment.

Projects in three main areas stood out as having the highest impact in the past or are expected to have high impact over the next 2 years:

- A few annual operating plan (AOP) projects led by national laboratories serve as a foundation for all of the other projects in the portfolio. These projects have enabled an in-depth understanding of the current SOT and have brought much needed standardization of methods. Stand outs include Arizona State University's (ASU's) ATP3 testbed and NREL's Algal Biofuels Techno-Economic Analysis and Compositional Analysis projects.
- Three industry-led deployment projects are seeking to demonstrate an integrated process at scale. The top-scoring project was GAI's ABY1, which appears to have demonstrated particularly impactful advances in productivity and harvesting/dewatering and claims to be well on the way to meeting BETO's targets.
- Given the understanding that co-products will be critical to meeting cost targets, several pursuits may be poised for high impact. This includes projects such as NREL's Algal Biomass Valorization and Algal Biomass Conversion, Algenol's Photobioreactor-Based Biorefinery, and the Colorado School of Mines-led Producing Algae for Co-Products and Energy (PACE) consortium.
- **Strain improvement:** Many investigators reported incremental but significant improvements in productivity. However, innovative tools and datasets coming online have the potential to greatly accelerate this progress. Several labs are exploring promising Cas9 methodologies, which may even allow the generation of non-genetically modified organisms engineered strains. Other advances—such as rapid strain screening methods, cell-sorting capabilities, classic breeding techniques, functional genomics databases, etc.—will further accelerate progress.
- **Carbon capture:** Several approaches to improving carbon capture are being explored, including a large-scale GAI absorber unit, ASU's membrane capture system, University of Toledo's high alkalinity cultivation, and PNNL's carbonic anhydrase studies. The potential for these innovative approaches to enable atmospheric CO₂ capture, if successful, could be transformational in relieving siting constraints.
- **Crop monitoring and protection:** Some investigators are addressing issues of culture instability due to predators and pathogens. Lawrence Livermore National Laboratory (LLNL) is seeking to understand pond microbiomes and select beneficial probiotic bacteria. A University of California, San Diego project is searching for chemical signatures of impending crashes. Such work is critical to increasing yields through crash prevention.
- **Algal polyculture using impaired water:** Cultivation of mixed algal cultures—such as Sandia National Laboratories' (SNL's) Algae Turf Scrubber and California Polytechnic State University's and MicroBio Engineering's wastewater projects—show promise for good productivity while providing water remediation benefits and simultaneously addressing nutrient recycle.
- **Direct fuel/product production systems:** Two of the most innovative projects seek to produce fuel/chemical intermediates directly in photobioreactors

Innovation

A high level of innovation was evident within the 39 projects presented. The flexibility of BETO's target-driven FOA process has been very successful in attracting innovative approaches. Some of the research areas that stood out to the Review Panel as being particularly innovative include the following:

(PBRs) using cyanobacteria (ethyl laurate at ASU and ethylene at NREL).

Synergies

Overall, the synergies between projects are excellent. Reviewers noted an unprecedented level of collaboration between groups. Several of the consortium projects—such as the Development of Integrated Screening, Cultivar Optimization, and Validation Research (DISCOVER); ATP3; and NREL’s Algae Biotechnology Partnership—stood out as models of inter-laboratory cooperation. There is little duplication of effort; approaches that appear similar are yielding different outcomes in different settings (i.e., some degree of redundancy is valuable).

Some additional opportunities for synergy were noted:

- Sharing knowledge between corporate and national laboratory projects has been limited and needs to be encouraged at all levels for cross-fertilization. This is particularly true in order to benefit calibration of TEA and life-cycle analysis (LCA) models.
- Interactions with industry are also lacking when it comes to product and co-product quality and integration. For example, several of the projects have attempted to quantify the impact of HTL for conversion of algal biomass to intermediates, and using the value of the intermediate in their TEA. However, there is no clear consensus on the value of these intermediates to a refiner, or the cost of upgrading the intermediates to an acceptable specification.
- Standardized methods (developed by NREL/ATP3) and biomass productivity units ($\text{g}/\text{m}^2/\text{day}$) have been embraced by most, but not all, teams in the portfolio. Productivity reporting for PBRs is particularly problematical.
- There is still little consensus on the best algal species, cultivation methods, and downstream processing approaches (e.g., combined algal processing versus HTL) to be pursuing, and projects are underway

to further broaden the scope of possibilities (e.g., DISCOVER and the Algae Biotechnology Partnership). A tighter focus would enhance cross-fertilization between projects. Given the number of unknowns and the fact that different situations may require different organisms and strategies, BETO should not impose down-selection at this point. However, the Office should monitor whether lack of focus is due to entrenched interests or true value in continuing to pursue alternatives.

- Projects proposing to integrate herbaceous feedstocks—such as the Idaho National Laboratory (INL) feedstocks logistics and ASU mixotrophy projects—should explore synergies with the cellulosic biomass industry.

Focus

The 39 projects reviewed represent very broad coverage of the entire value chain, including strain improvement and tool development, cultivation practices, crop protection, storage, downstream processing, fuel intermediates, co-products, sustainability, techno-economics, etc. The emphasis placed on each of these areas seems appropriate.

No notable gaps were identified; however, one consistent theme is lack of interaction with end users, particularly refiners that would purchase fuel intermediates or industries that would purchase or market co-products. It would be useful for DOE to sponsor projects with recognized industrial experts to determine the cost of upgrading fuel intermediates and co-products and the corresponding value of the upgraded materials.

There appears to be relatively little ongoing work on algal harvesting and dewatering. Some players might argue that this has been solved; if so, that needs to be definitively demonstrated since this is a critical barrier.

Finally, there is always room for more disruptive technologies and out-of-the-box thinking that could lead to greater than incremental improvements. This can

continue to be encouraged through FOAs that allow for flexibility in the investigators' approach.

Commercialization

BETO is appropriately funding projects across the technology readiness level spectrum, from early stage research to later-stage deployment at relatively large scale. There has been an excellent tie-in between TEA and LCA results and BETO's decision making. Some of the national laboratory efforts could benefit from closer interactions with industrial growers to ensure their developments will satisfy commercial needs. Promoting more direct interaction between PIs and end users would help to obviate surprises or showstoppers, such as was found with devalued HTL-derived fuel intermediates due to quality issues such as high metals content.

It is clear that identifying appropriate co-products with relatively large market size and sufficiently high value will be a critical challenge over the next 2 years. It is also important to identify co-products where algae pose a unique advantage, rather than simply competing with other commodities such as corn starch. There is little, if any, consensus on what the best target co-products will be. Perhaps BETO could work to help refine the co-product options through engagement of industrial interests. Currently, the value of many algae-derived co-products is assumed rather than demonstrated; funding research on actual co-product utilization (e.g., algal meal feeding trials or studies of algal co-polymers) could be of value.

Regulatory issues need to be dealt with more systematically, including genetically modified organism (GMO) deployment issues and genetically modified product requirements for many co-products.

The Review Panel's recommendations fall into three categories:

1) **Productivity improvements:** Improving the yield of algal biomass and useful compounds therein should continue to be of highest priority.

- Ongoing work on upstream components is critical. This includes tool development, strain engineering, photosynthetic efficiency enhancement, carbon uptake, product/co-product yields, cultivation practices, crash resistance, etc.
- Further improvements are needed in realistic lab-scale testing and iteration between lab and field (demonstrations under real-world conditions, long-time scales, and large pond sizes).
- Current FOAs are limited to pond sizes of 60,000 liters (L) and smaller, which is too small to really demonstrate commercial applicability.
- Funding of both further incremental improvements and high-risk, potentially transformational concepts should continue.

2) **Connections with industry:** Better ties between laboratory researchers and industrial interests are needed.

- Concepts aimed at growth enhancement or crop protection need buy-in from real-world algal producers.
- Modelers need more input from producers to realistically capture effects of nutrient loss, harvesting schedules, downtime, etc.
- Thorough market assessments and sensitivity analyses are needed for the evaluation of potential co-products.
- Researchers and industry should work together toward consensus on what types of products are particularly well suited to production in algal systems.
- Buy-in from end users of fuel intermediates and co-products is needed, including an understanding of cost penalties associated with quality issues.
- The value of algae-derived co-products should be demonstrated (e.g., feeding trials for algal meal).
- Mechanisms are needed to leverage valuable data confined within companies that are receiving funding from BETO. This should include lessons learned, not just the successes.

3) **Agronomic approaches:** The Review Panel would like to see algal cultivation treated more as agriculture than biotechnology. Agronomic approaches to crop improvement and integrated pest management are needed, possibly in collaboration with the U.S. Department of Agriculture and trained agronomists. Approaches should be evaluated under realistic condi-

tions at large scales with best management practices; long-term field testing (greater than 1 year, across seasons) is needed for meaningful results. Associated regulatory issues need to be addressed, including both GMO deployment and genetically modified product protocols for co-products.

ADVANCED ALGAL SYSTEMS PROGRAMMATIC RESPONSE

Introduction/Overview

The Advanced Algal Systems Program would like to thank the Review Panel for recognizing the success of the BETO-funded portfolio in advancing the SOT and the effectiveness of the program strategy, as informed by our rigorous analysis portfolio. The program is working to continually advance in areas identified by national laboratory-led analysis as the most impactful: productivity improvements and increasing the value of biomass through investigation of co-products. BETO also thanks the panel for acknowledging how critical government funding is in supporting these innovative technologies in order to reduce risks for private investors. The program will continue to focus on improvements at a variety of pre-pilot R&D technology readiness levels at the national laboratories and through competitive FOAs.

The Review Panel affirmed that BETO funding has enabled innovative approaches, significant advances along the SOT, and unprecedented synergies among projects. While the panel noted that gaps were not significant, we acknowledge that the program's dedicated work in harvesting, dewatering, and logistics was absent from this review because it is focused within the Small Business Innovative Research portfolio, though the Algal

Biomass Yield portfolio also includes “downstream” logistics within project plans, notably the GAI Zobi Harvester®. With regard to regulatory issues related to GMO deployment, BETO is coordinating closely with the Environmental Protection Agency through the Biomass Research and Development Board to provide guidance on permitting requirements managed by that agency. We also concur that there is always room for more disruptive technologies, and the program will continue to encourage non-incremental improvements through FOAs that allow for flexibility in the investigators' approach.

Recommendation 1: Focus on improving the productivity of biomass production

The Review Panel's key recommendation to the program is to focus on improving the productivity of biomass production. The program fully agrees with this recommendation and has focused R&D on achieving productivity targets for the last several years. Biomass productivity and biofuel yield have been key targets in the program's competitive funding opportunities since 2013. Future work will continue to keep productivity as our highest priority, focused on biological improvements tested in outdoor-relevant conditions. In addition to the existing portfolio's efforts in strain improvement, the program is initiating a new program under the Productivity Enhanced Algae and ToolKits funding oppor-

tunity—announced in Fiscal Year (FY) 2017—to not only set new targets for productivity and yield, but also to create tools and methods to advance the SOT across the field.

Recommendation 2: Establish better ties between laboratory researchers and industrial interests

The program agrees that there needs to be better ties between national laboratory researchers and industrial interests, and we hope to continue fostering interactions with industry boards. The program discusses industrial interests regularly with the Algae Biomass Organization through stakeholder meetings, listening days, workshops, and conferences. The program will continue to leverage the industrial boards of ATP3 and other competitive projects and encourage relationships between national laboratories and private partners. The national laboratory DISCOVER consortium, for example, is soliciting strains from industrial partners to test through its “pipeline” process. Going forward, the program will be sure to critically evaluate and improve upon “tech-to-market” plans of the national laboratories, as well as support partnerships between industry and fundamental R&D.

Recommendation 3: Develop agronomic approaches to crop improvement and integrated pest management

The Advanced Algal Systems Program solicited agronomic approaches to crop protection and pest management in topic two of the FY 2015 Targeted Algae Biofuels and Bioproducts FOA, as well as the FY 2017 Productivity Enhanced Algae and ToolKits FOA. The program agrees that agronomic approaches are a necessary element in this field of study and is pursuing R&D strategies to improve the state of cultivation technology of the NREL Algae Farm design case.¹⁸ We concur that algal cultivation should be envisioned as a large-scale agricultural practice and not only as a biotechnology. Long-term outdoor field testing at meaningful scales is planned per our MYPP, within a 5-year time frame. BETO will continue to coordinate with the U.S. Department of Agriculture and Environmental Protection Agency through the Biomass Research and Development Board on issues such as GMO deployment.

¹⁸ Ryan Davis, Jennifer Markham, Christopher Kinchin, Nicholas Grindl, Eric C. D. Tan, and David Humbird, *Process Design and Economics for the Production of Algal Biomass: Algal Biomass Production in Open Pond Systems and Processing Through Dewatering for Downstream Conversion* (Golden, CO: National Renewable Energy Laboratory, February 2016), NREL/TP-5100-64772, <http://www.nrel.gov/docs/fy16osti/64772.pdf>.

MICROALGAE ANALYSIS

(WBS #: 1.3.1.102)

Project Description

An important step toward realizing the biofuel potential of algae is quantifying the demands commercial-scale algal biofuel production will place on water, land, and nutrient resources. This project developed and advances a high-resolution spatiotemporal Biomass Assessment Tool (BAT) focused on fundamental questions of where production can occur; what are the associated demands for nutrient, land, and water resources; how much energy is produced; and, by evaluating numerous trade-offs, where the ideal production sites are located. To help answer these questions, the BAT considers site-specific, high-fidelity climate information; existing land use/land cover; transportation networks; known and quantified nutrient sources; and refinery infrastructure. The BAT provides a biophysics-based analysis tool for linking key BETO and industry research activities to achieve

Recipient:	Pacific Northwest National Laboratory
Principal Investigator:	Mark Wigmosta
Project Dates:	10/1/2015–9/30/2018
Project Category:	Ongoing
Project Type:	AOP
DOE Funding FY 2014:	\$600,000
DOE Funding FY 2015:	\$900,000
DOE Funding FY 2016:	\$800,389
DOE Funding FY 2017:	\$600,000

high-impact objectives. Results from this study have resulted in 15 peer reviewed publications of direct benefit to industry for evaluating optimal site locations, strains, and operations.

Overall Impressions

- The model they are developing is very detailed in terms of selecting the parameters required to make an informed site selection. For cases where they model strain rotation, it would be a good addition

Weighted Project Score: 7.8

Weighting: For ongoing projects, there is equal weighting across all four evaluation criteria: Approach, Relevance, Accomplishments and Progress, and Future Work.

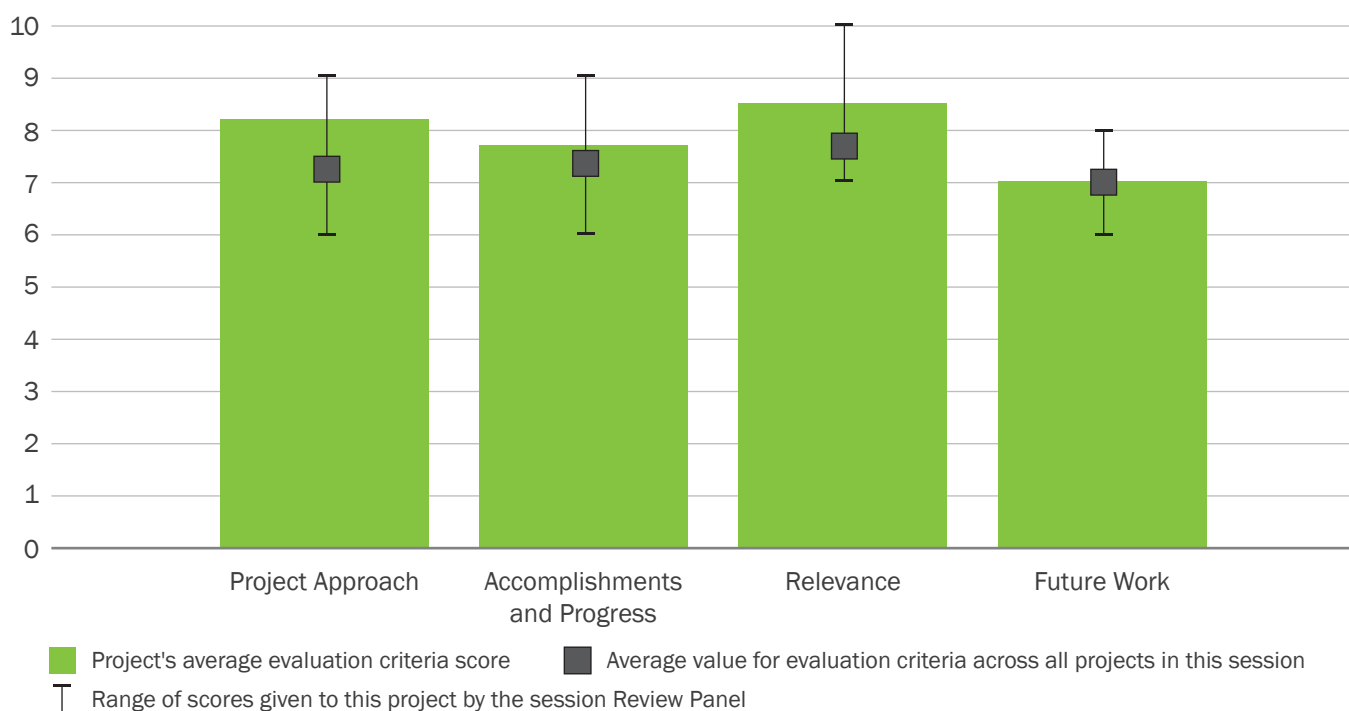

to include the scheduling inefficiencies encountered using this approach. This model will be very helpful for assisting industry with their decision making and helping policymakers in evaluating the potential of the algae industry.

- This is one of the bedrock projects in the portfolio, and key findings from this work have continued to help guide the program. Integrating soil-type data to glean information on where pond liners would be required could be a valuable addition.
- The continued development of sound site-specific TEA analysis is an important component of the successful deployment of large-scale algal biomass productivities. Overall, this project addresses the majority of questions and issues related with certain large-scale production sites. The model could incorporate more detailed information on water availability on a state-by-state basis to provide more clarity as to how much water resource is available given a specific state's regulatory issues.
- The BAT should be a key tool for the industry as it expands. Anyone considering building or buying algae production facilities should be using it as part of their due diligence efforts. Proposed improvements to the tool via the future work will enhance it greatly, particularly the inclusion of alternative paths to biomass production.
- This project fits well within the BETO portfolio by providing a tool focused on assessing resources required for the large-scale production of fuel from microalgae, an essential component of determining the viability and scale-up of algal-derived fuels. The project has been productive with important key findings, such as the significant potential for production using saline water and co-location with CO₂ sources.
- The team has made strong contributions to biomass assessment efforts in the past with clear links to BETO MYPP goals. Overall, the goals and

milestones for the new 3-year effort were unclear, including how those goals differed from previous efforts.

PI Response to Reviewer Comments

- We thank the reviewers for their valuable and encouraging input. For all aspects of the BAT, we have strived to develop components and a level of detail required by BETO, MYPP goals, and the algae research community. By design, we use a systematic process of building a best representation and then subsequently add additional detail as the needs and data support. This approach helps to identify research needs and data gaps, for BETO and others in the algae community. When gaps are filled, we are able to utilize these results and continue to build more detail and rigor into the BAT.

We agree with the reviewers that BAT/TEA integration is critical. BAT calculates some spatially derived TEA components (cost of pipeline/well drilling/water transport, land valuation, land preparation, transport costs of moving biocrude to refineries, etc.). Through BETO model harmonization efforts, we continue to integrate resource assessments with TEA models (i.e., NREL). This combination allows site-specific analyses to be conducted throughout the United States and allows results and research to be shared, which has been done through direct working relationships with industry, trade groups, conference talks, and publications.

Major cost barriers associated with pond liners drives the need to evaluate soils and respective infiltration of pond water into those soils. We built a preliminary soil-plugging model based on a national soils database that uses soil texture, organic matter content, and cation-exchange capacity to develop estimates of saturated conductivity under both natural and compacted soil conditions to aid with this assessment. This analysis would benefit from additional research.

We are developing more detail into our water availability models, including sustainable water use that considers environmental flow requirements and seasonal use, along with other existing competitive uses. This will significantly improve our previous approach. In addition, we are evaluating site operation strategies (e.g., pond operating depth, harvest strategies, water recycle) to gain a more realistic representation of water use. In the past, we have proposed evaluating state regulatory water issues and factoring these into the BAT and agree that this topic should be considered—at least for the states that show the most promise for production.

We agree with the reviewers in that our strain rotation work needs additional ‘operational’ detail, particularly in how we represent the logistics of switching strains. What has been presented shows a first-order evaluation of the possible production potential by implementing rotations to reflect seasonal environmental conditions at a monthly time-step. We need to obtain operational data of strain rotations so we can better represent the processes and effects. To this end, we are also using the BAT to help inform experimental design under the Regional Algae Feedstock Testbeds (RAFT) program. We expect data and feedback from the RAFT and ATP3 programs to provide data on relevant operational details.

Key efforts over the next 3 years include the following:

- Developing an improved estimate of sustainable algal biomass productivity for harmonized assessment (with Argonne National Laboratory, NREL, and Oak Ridge National Laboratory), including CO₂ co-location, saline versus fresh water, requirement for liners, and maximum farm size.
- Using improved site-specific operations to increase seasonal and annual feedstock production.
- Establishing improved metrics for sustainable algal feedstock production to reduce impact to water and land resources (with Oak Ridge National Laboratory) considering environmental flows, water quality, and additional saline water constraints.
- Gaining an improved understanding of the trade-offs associated with alternative pathways to meet MYPP 2018 and 2020 production targets considering the use of PBRs and CO₂ co-location.
- Quantifying the feedstock production potential associated with alternative sources of nutrients (wastewater; concentrated animal feeding operation) that contribute to a continental United States-wide trade-off analysis.
- Providing BAT model support to SOT reports.

ALGAE POLY CULTURE CONVERSION AND ANALYSIS

(WBS #: 1.3.1.103)

Project Description

The overall objective of this project is to establish the technical and economic feasibility of achieving and scaling high and reliable production of easy-to-harvest algal turf polyculture for biofuels using fresh and estuarine/marine surface waterways without supplemental CO₂ and nutrients addition. Commercial algal turf scrubber systems deployed for cleaning water have not been optimized for biomass production, but rather for the treatment and reduction of nitrogen and phosphorous contamination in surface waters in the environment to extremely low levels at discharge. Extrapolation of the productivities observed over a year give an annual yield

Recipient:	Sandia National Laboratories
Principal Investigator:	Ryan W. Davis
Project Dates:	10/1/2015–9/30/2018
Project Category:	Ongoing
Project Type:	AOP
DOE Funding FY 2014:	\$0
DOE Funding FY 2015:	\$440,000
DOE Funding FY 2016:	\$950,000
DOE Funding FY 2017:	\$750,000

of more than 34 tons per acre, per year. Through this project, we seek to increase productivity to 18–25 g/m²/day ash free dry weight by optimizing cultivation and harvesting system operations and reducing biomass losses. Finally, combining techno-economic, resource, and geographic information assessments are being applied to determine U.S. scale-up potential.

Weighted Project Score: 6.6

Weighting: For ongoing projects, there is equal weighting across all four evaluation criteria: Approach, Relevance, Accomplishments and Progress, and Future Work.

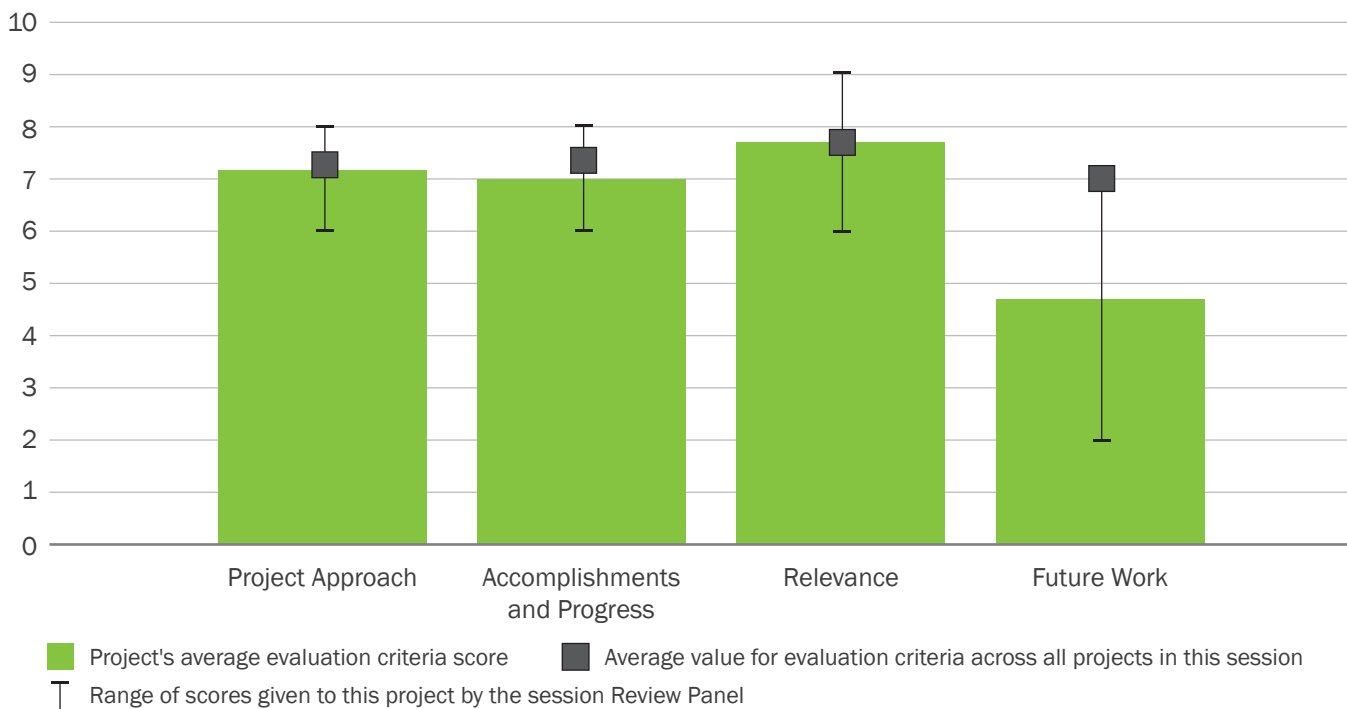

Overall Impressions

- This is a promising project for economical water cleanup. Future work should include improving the productivity, working on algae cleanup, and developing a strong TEA for an identified site. While this approach may be a difficult method to meet the productivity goals of the MYPP, it may be better suited for meeting sustainability goals.
- This approach lends important diversity to the portfolio. The project has both revealed promise (such as good productivity and the scale of available resources) and challenges (such as the very high ash content). Critical deliverables for the remainder of the project should include detailed water analysis before and after treatment, analysis of the suitability of the biomass for downstream processing, and completion of TEA/LCA.
- Overall, this is a well-planned and deployed project that could provide a feasible methodology for the production of algal biomass using wastewater technology and phycoremediation. Issues of scaling the system could be problematic. Setting this system up in a manner that is “off the grid” provides an interesting approach for stand-alone automated systems that could reduce the overall operating cost of this type of system.

- This is an excellent contribution for algae biomass production, and making the best of waste from one industry into products for another, if this can scale as predicted in the project and is economically feasible.
- Using the algal turf scrubber system to cultivate algae for fuel is very interesting, though there may be some critical issues to overcome, such as lower-than-expected productivity and high ash content. This project has made some demonstrable progress toward producing biomass with this system, but should focus on a clear plan for future work to ensure continued progress and relevance.
- The project has installed, operated, and generated data from an innovative technology package. Early data suggests productivities approach current microalgal SOT. It is unclear whether the biomass generated from this technology package will be compatible with conversion technologies for fuel applications, but the technology may provide valuable water treatment services in certain situations.

PI Response to Reviewer Comments

- The AOP team would like to thank the reviewers for their generous contributions toward the success of this and the associated BETO Advanced Algal Systems projects. Their feedback was greatly appreciated.

ALGAL BIOFUELS TECHNO-ECONOMIC ANALYSIS

(WBS #: 1.3.1.200)

Project Description

The objective of this project is to provide process modeling and analysis to support Advanced Algal Systems Program activities, utilizing process and economic models to relate key process parameters with overall economics for cultivation, processing, and conversion of algal biomass to fuels and co-products. By quantifying economic implications of key process metrics, TEA models highlight the requirements to achieve future program cost goals, as well as provide a means for tracking progress toward these goals. This project is highly relevant to BETO objectives because it produces critical cost data tied to funded research at NREL and elsewhere, with the analyses subsequently exercised

Recipient:	National Renewable Energy Laboratory
Principal Investigator:	Ryan Davis
Project Dates:	10/1/2016–9/30/2019
Project Category:	Ongoing
Project Type:	AOP
DOE Funding FY 2014:	\$0
DOE Funding FY 2015:	\$350,000
DOE Funding FY 2016:	\$300,000
DOE Funding FY 2017:	\$300,000

by BETO to guide program plans, FOA priorities, and other strategies to guide research toward achievement of cost targets that are set from the “top-down.” Moreover, our work strives to address the large disparity in public claims regarding cost potential for algal biofuels by establishing rigorous, peer reviewed cost models based on multiple input sources. The Algal Biofuels TEA project has made significant achievements since the 2015 Peer Review, including publication of a new “algae farm”

Weighted Project Score: 8.2

Weighting: For ongoing projects, there is equal weighting across all four evaluation criteria: Approach, Relevance, Accomplishments and Progress, and Future Work.

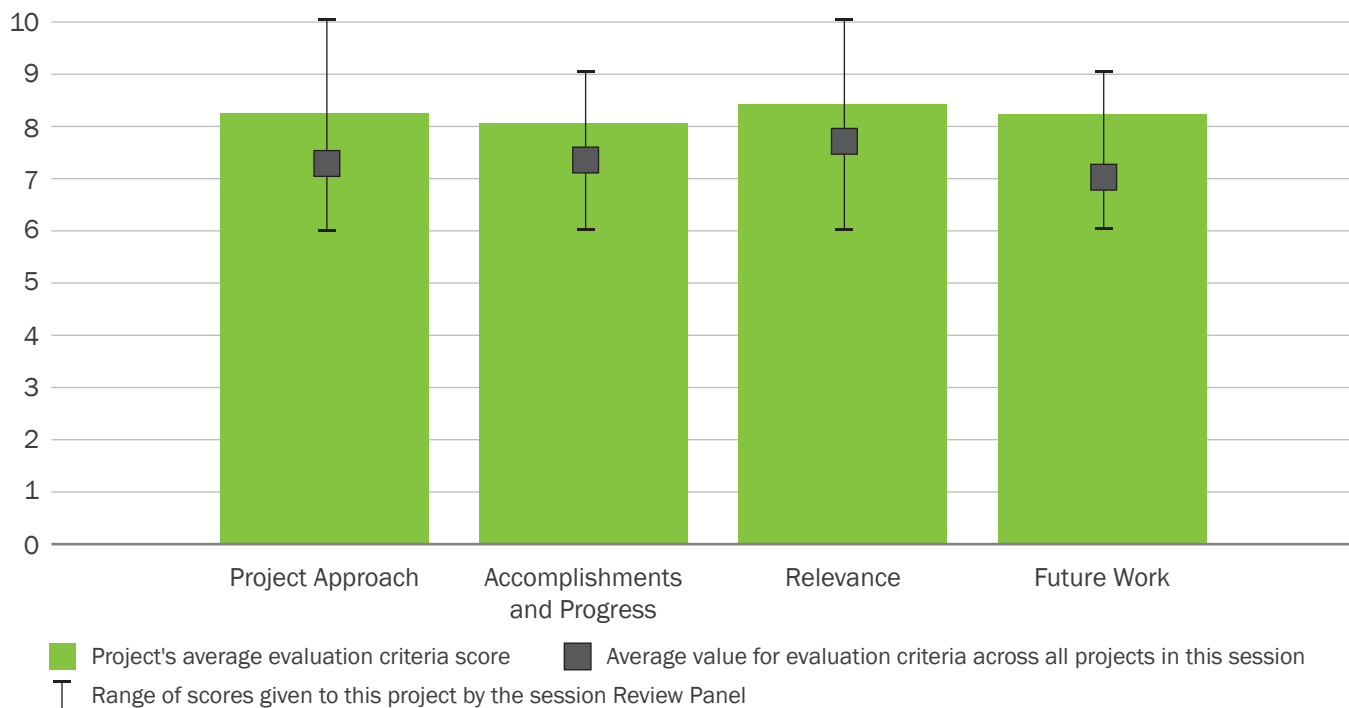

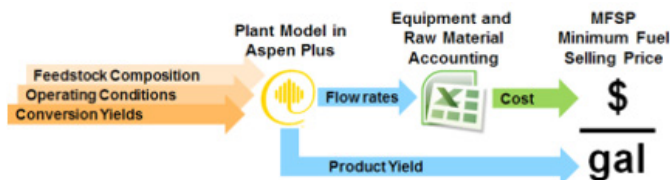

design report that documents cost projections for algal biomass cultivation and harvesting, as well as demonstrates viable paths to achieving \$3/gge fuel cost targets by 2022 as set by BETO, based on co-production of fuels and value-added co-products.

Overall Impressions

- This project is one of the essential core elements of the portfolio. Its past and future work provides unbiased data for BETO and industry to direct their resources. Continued emphasis on co-products is critical.
- The continued development of sound and relevant TEA for the use of defining and identifying gaps within the current knowledge base of large-scale algal biofuel production is important. These studies have a great research impact, as they provide a blueprint for current or needed optimization within the field. More interaction with large-scale production cultivators may help to focus the TEA. Possibly, interaction with commercially viable nutraceutical systems that are currently in operation may shed some light on areas or processes that have already been or are being explored.
- This TEA project is large and complex, but it provides clear direction for areas that must be targeted for additional work in order to meet cost per gge (or cost per ton of biomass).

- This project has been an essential part of setting BETO benchmarks and thereby has driven progress across several other projects in the BETO portfolio.
- This project has made strong contributions to benchmarking the state-of-the-art in algal biofuel technology pathways. The proposed future work is expected to continue being highly valuable to BETO in helping to monitor the progress of the Office’s algal portfolio and helping to prioritize future funding efforts. The team has a strong track record of collaboration, and the proposed future work should continue that trend.

PI Response to Reviewer Comments

- We thank the reviewers for their positive feedback in recognizing the utility of this project for BETO and the algae community. We plan to continue leveraging the expertise established for both algal biomass production and conversion TEA models to update SOT benchmarks and track progress against future cost goals, and to provide insights that industry may build upon regarding algal biomass valorization opportunities for fuels and co-products. We do have a number of working relationships with stakeholders in industry, and we hope to continue those discussions and reach out to others to leverage existing knowledge they’ve established in validating or improving our models. We always welcome such inputs and also would gladly seek similar guidance from other related industries, such as nutraceutical producers (although recognizing that there may be some differences in processing practices, constraints, and costs between nutraceutical production and commodity-scale fuels and other products).

ALGAE TECHNOLOGY EDUCATIONAL CONSORTIUM

(WBS #: 1.3.1.201)

Project Description

The Algae Technology Educational Consortium (ATEC) project was created to support BETO’s vision of the algal industry and bioeconomy growth by training technicians to meet the 12,000 positions anticipated by 2021. The Algae Foundation and NREL have collaborated to lead a consortium of academic and commercial algal experts to develop two separate community college degrees in algal farming and biotechnology—providing an educational platform resulting in the next generation of algal professionals. Additionally, ATEC has assembled an industrial advisory board comprised of senior management from America’s leading algal companies to ensure that the ATEC skill set meets industry needs. An ATEC jobs survey identified present and future job op-

Recipient:	National Renewable Energy Laboratory
Principal Investigator:	Cindy Gerk
Project Dates:	10/1/2015–9/30/2018
Project Category:	Ongoing
Project Type:	AOP
DOE Funding FY 2014:	\$0
DOE Funding FY 2015:	\$250,000
DOE Funding FY 2016:	\$55,000
DOE Funding FY 2017:	\$600,000

portunities. Future efforts include formalizing relationships with more community colleges; online courses; institutionalization of the intensive, in-person laboratory courses; distribution of the Algae Cultivation Extension Short-course learning modules; distribution and analysis of the second generation algal-based jobs survey, targeting the biotechnology and wastewater treatment industries; and curriculum and learning outcome assessment by an external educational assessment team and the ATEC industrial advisory board. ATEC continues to

Weighted Project Score: 8.7

Weighting: For ongoing projects, there is equal weighting across all four evaluation criteria: Approach, Relevance, Accomplishments and Progress, and Future Work.

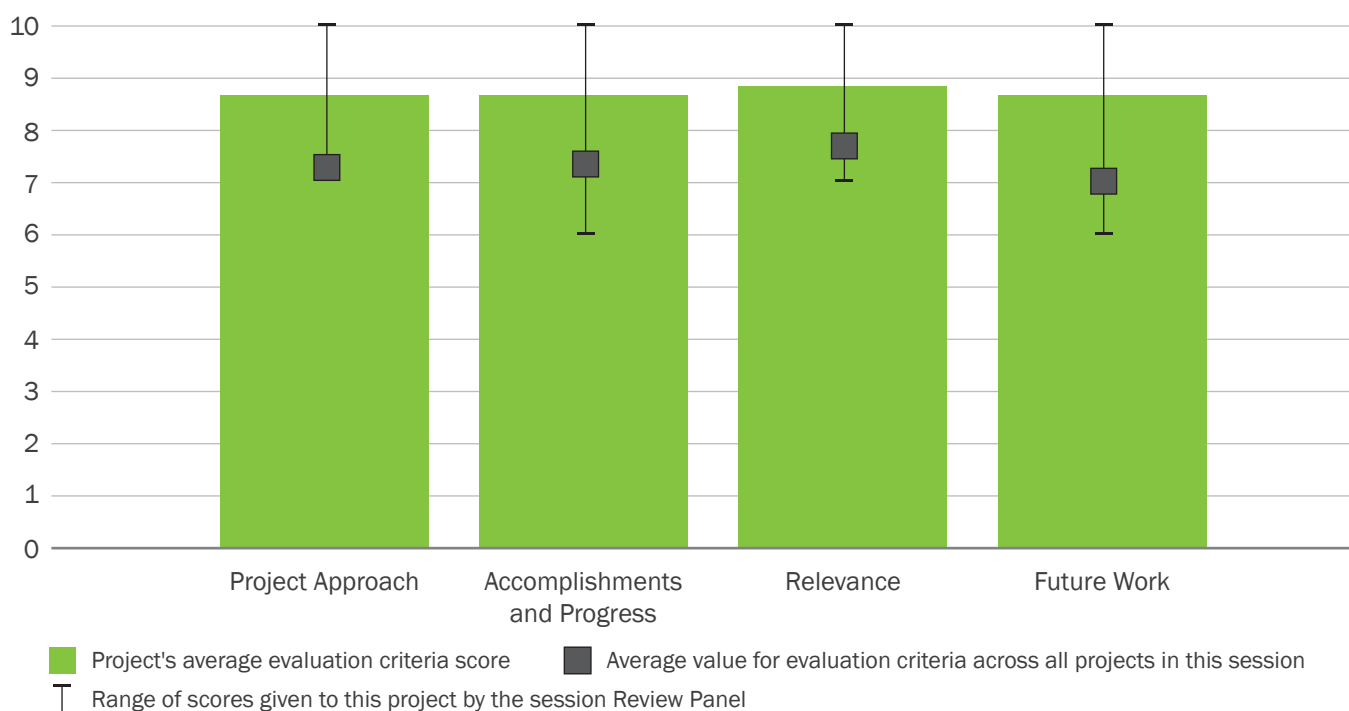

engage all stakeholders and pursues collaborative relationships with algal companies, academics, and community colleges.

Overall Impressions

- This is a very exciting project. The project effort is important and relevant for meeting several DOE objectives, and it addresses industrial challenges for finding and retaining trained professionals (in particular, in some of the rural regions). This project would also be very relevant for the U.S. Department of Agriculture's goals. The project is very excellent at identifying schools that already have biotechnology or related degrees and adding in the algae component, other colleges, and an online course. The project has good insights on methods and goals for how to teach college students and for coordinating with algae companies to make the course relevant and acceptable to the industry.
 - This project is already yielding great 'bang for the buck' and is gaining traction on the introduction of algal technology degree programs and coursework. Assuming growth of the industry proceeds as anticipated by the survey, such a program will be essential to meet the industry's workforce needs in the coming years. The diversity of approaches and functions of ATEC, such as the proposed free Massive Open Online Courses (MOOC) and internship coordination, will go far toward serving the community.
 - Overall, this project is a forward-thinking approach to combat the growing need for skilled workers in the future.
 - Training programs are dearly needed; in addition to providing required skills sets, they also help promote awareness and interest in the industry. It would be a wonderful addition if this project could modify its curriculum or promote its MOOC to extend to continuing education or job training for existing employees.
- This is an excellent, thoughtful, and creatively approached project that will undoubtedly support a growing industry by providing a skilled workforce to companies that don't necessarily have the resources to train their own. Likewise, this effort will serve students by preparing them to be effective contributors to a developing field.
 - The team appears to have met all original goals and continues to make a strong contribution to workforce development for the algae biofuels industry. The group is building early learnings into future plans and is poised to reach a wide audience with education and training activities that should be applicable to adjacent industries, as well as the nascent algal biofuels industry.

PI Response to Reviewer Comments

- ATEC is grateful to the reviewers for their insightful comments and suggestions. We thank the reviewers for their support and encouragement as ATEC moves forward in achieving more successes, generating additional momentum from academia, and producing the first class of graduates to enter the workforce in the growing algae industry.

The ATEC flowchart clearly indicates that the MOOC is the 'interest generator' for the entire ATECs program. We have always envisioned the MOOC would come first for all participants, including our two community college degrees; Algae Cultivation Extension Short-course learning modules; or alternative existing programs, including ATP3, the University of California, San Diego Edge Program, or Maine Kelp Farming educational efforts. The Algae Foundation fully intends to disseminate and advertise the MOOC in our publications, professional presentations, social media, and all of our degrees and Algae Cultivation Extension Short-course efforts.

The concept of pre-training employees is the very essence of the ATEC philosophy. As the owner of an algal farm, two of three new hires didn't last more than 1 week. Either they were ill prepared or we were poor teachers. Either way, the existence of the ATEC farming degree would have been invaluable

to our operational efficiencies and budget. ATEC degree programs are built around understanding the skills and mindset expected in new employees, and we instill these experiences and values into our training and educational program.

SUSTAINABLE DEVELOPMENT OF ALGAE FOR BIOFUEL

(WBS #: 1.3.1.500)

Project Description

This project supports the development of a sustainable and cost-effective domestic supply of algal biomass, biofuels, and bioproducts. Environmental and socioeconomic indicators for measuring and modeling aspects of sustainability were developed, published, and are being used to identify sustainability synergies and trade-offs. Co-location of algae with waste CO₂ sources can improve profitability while also improving key environmental indicators and energy return on investment. We estimated, for the first time, both the potential algal biomass and qualitative environmental effects across the United States, and results were presented in the *2016 Billion-Ton Report*. We have completed proof-of-principle experiments showing that the addition of carbon

Recipient:	Oak Ridge National Laboratory
Principal Investigator:	Rebecca Efrogmson
Project Dates:	10/1/2015–9/30/2018
Project Category:	Ongoing
Project Type:	AOP
DOE Funding FY 2014:	\$200,000
DOE Funding FY 2015:	\$800,000
DOE Funding FY 2016:	\$465,000
DOE Funding FY 2017:	\$83,000

sources and/or algae can reduce soil conductivity—a prerequisite to determining locations and conditions for which unlined or minimally lined ponds could be feasible while maintaining water quality and quantity. We identified algal strains that are synergistic, out producing monocultures when grown together in model wastewater conditions. These polycultures have the potential to decrease susceptibility to pond crashes, moving toward energy security, and improve water quality and quantity. Food security from joint production of protein

Weighted Project Score: 5.6

Weighting: For ongoing projects, there is equal weighting across all four evaluation criteria: Approach, Relevance, Accomplishments and Progress, and Future Work.

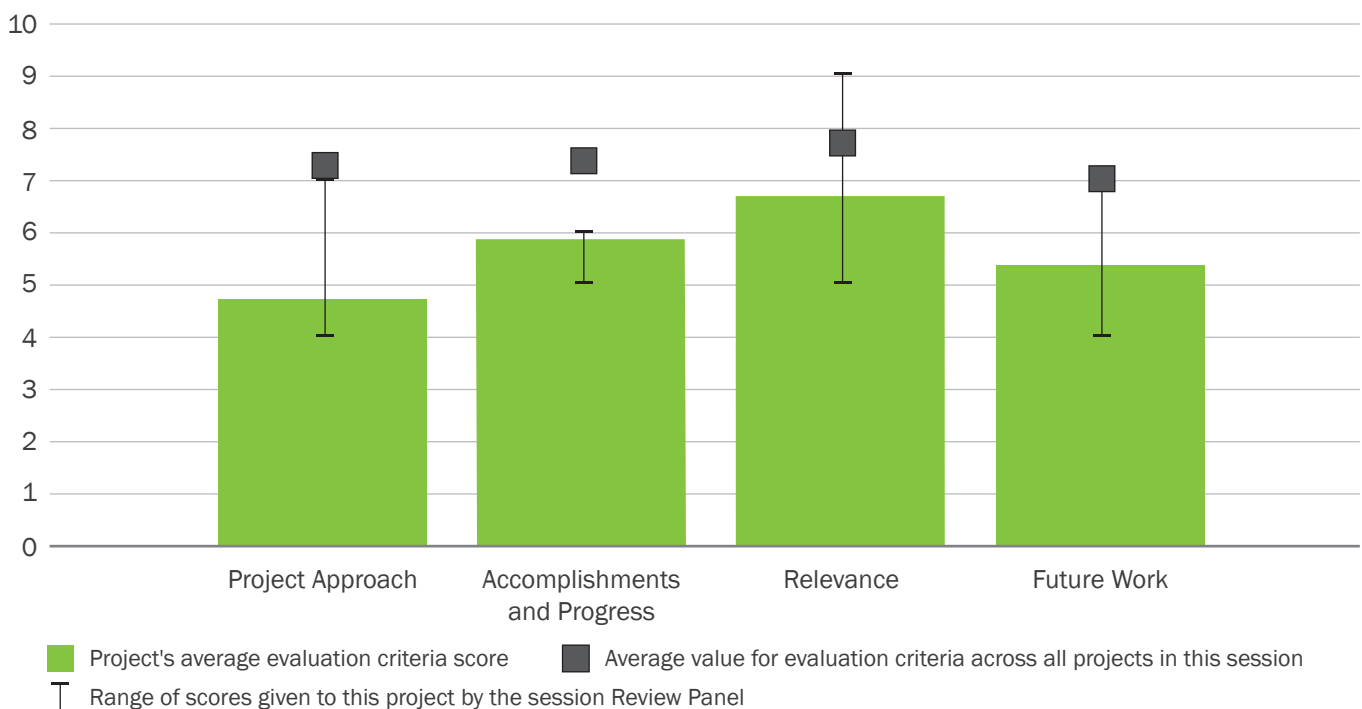



and energy from algae will be considered in the future. Efforts are underway to identify criteria, data, models, and regions to meet DOE's goal to model 1 million tons of sustainable algal biomass.

Overall Impressions

- This effort seems very disjointed. It is difficult to understand the goals, how they are related, and what was performed as part of this project or performed under other projects. It appears that this project changed over time, and that the accomplishment and emphasis end up not 100% aligned with original goals. The stated conclusions appear to be more directional in nature, and they are not very definitive. I think this presentation would have benefited from a “cold-eyes” review to help the presenter communicate to the Review Panel.
- Important areas of sustainability (economic, environmental, and socioeconomic) are being investigated. The project made important contributions to the *2016 Billion-Ton Report*. Overall, though, the project appears disjointed and relatively lacking in quantitative deliverables.
- Overall, the analysis and incorporation of sustainable practices to large-scale production systems has importance.
- Fully evaluating all potential inputs for sustainability and issuing a best management practices tool will

be extremely useful for the industry; however, there needs to be strong industry involvement to make it relevant.

- Vaguely, this project aims to make algae fuels sustainable through defining indicators of sustainability, establishing best practices, and identifying challenges for commercialization. However, the overall approach to accomplish this is not particularly cohesive or well-defined.
- Overall, the project has made strong contributions to BETO's goals for modeling the supply of sustainable algal biomass. The project seems to include several bench science efforts that are not integrated with the modeling work in terms of management, goals, or relevance. Future work also seems beyond the scope of original project goals and seems unlikely to succeed given the current team members.

PI Response to Reviewer Comments

- Reviewers found that the project is important and relevant to the platform goals and objectives of the BETO MYPP (“...the project has made strong contributions to BETO's goals for modeling the supply of sustainable algal biomass.”) The CO₂ co-location contributions to the *2016 Billion-Ton Report* were highlighted as a significant accomplishment.

Some reviewers felt that the objectives were well framed, but a few reviewers felt that presenting the

breadth without a more comprehensive discussion of the links among tasks, the project history, and the integrated management approach made the project seem disjointed. The presentation involves a few different tasks related to sustainability and resource analysis of algal biomass production. In the time allotted for the presentation, we were not able to clearly convey how all tasks were linked, but we have made a concerted effort to coordinate objectives among tasks and between labs. Also, the resource analysis work was moved to a feedstock platform project to focus this sustainability project more on its sustainability roots, yet the resource analysis task was presented in the algae platform to get expert feedback.

The overall focus of this project is now on sustainable biomass, indicators, targets, and best practices, with a broad definition of sustainability. The project's two proof-of-concept tasks (unlined ponds and polycultures in wastewater) were re-

sponses to the following key needs for sustainable algal production: (1) reducing costs, (2) reducing freshwater consumption and nutrient consumption, (3) maintaining water quality, and (4) increasing productivity. The specific lab studies were not being done elsewhere, and the expertise to do them was at Oak Ridge National Laboratory. These lab studies end this year. The project will continue to identify sustainability needs and conduct needed research on different indicators, as well as best management practices.

There were some concerns about our future work in food security; we have a diverse team of economists, agricultural engineers, landscape ecologists, and other experts who have focused on food security issues for many years. We believe that food security is a real advantage of algae (potential co-products, use of non-agricultural lands, etc.), and that it is relevant to sustainability goals.

FUNCTIONAL CHARACTERIZATION OF CELLULAR METABOLISM

(WBS #: 1.3.2.100)

Project Description

The goals of this project are to advance technical capabilities for rapid strain improvement in productivity and robustness. We will expand the molecular toolbox through Cas9 editing of key regulatory genes involved in nitrate sensing and signaling in *Nannochloropsis salina* CCMP1776. Overexpression of assimilatory proteins, including chloroplastic and cytosolic glutamine synthetase, and asparagine synthase will be explored for altering carbon/nitrogen balance in coordination with overexpression of phosphoenolpyruvate carboxylase for anapleurotic carbon backbone biosynthesis. This project will also focus on developing novel applications of flow cytometry probes for rapid characterization of algal cell physiological status. Phenotyping cells for lipid accumulation,

Recipient:	Los Alamos National Laboratory
Principal Investigator:	Scott Twary
Project Dates:	10/1/2016–9/30/2019
Project Category:	Ongoing
Project Type:	AOP
DOE Funding FY 2014:	\$1,000,000
DOE Funding FY 2015:	\$1,000,000
DOE Funding FY 2016:	\$1,000,000
DOE Funding FY 2017:	\$650,000

intracellular pH, REDOX status, autophagy responses, and cell cycle/ DNA ploidy will be developed and applied to multiple production species. We have demonstrated a linear pH response with pHrodo Green AM in *Picochlorum* and DNA ploidy responses with DyeCycle Orange. Application of these rapid assays will allow for developing a basis for understanding population responses to environmental stimuli and optimizing algae systems.

Weighted Project Score: 6.7

Weighting: For ongoing projects, there is equal weighting across all four evaluation criteria: Approach, Relevance, Accomplishments and Progress, and Future Work.

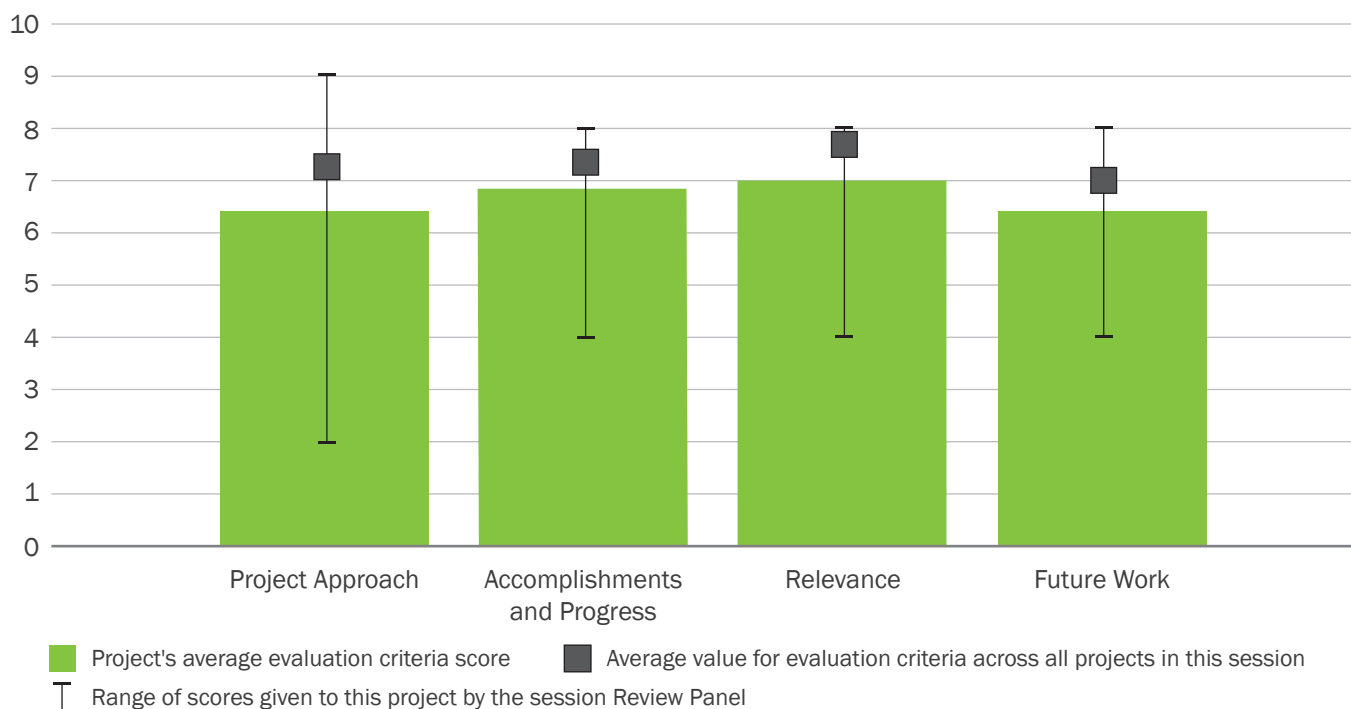

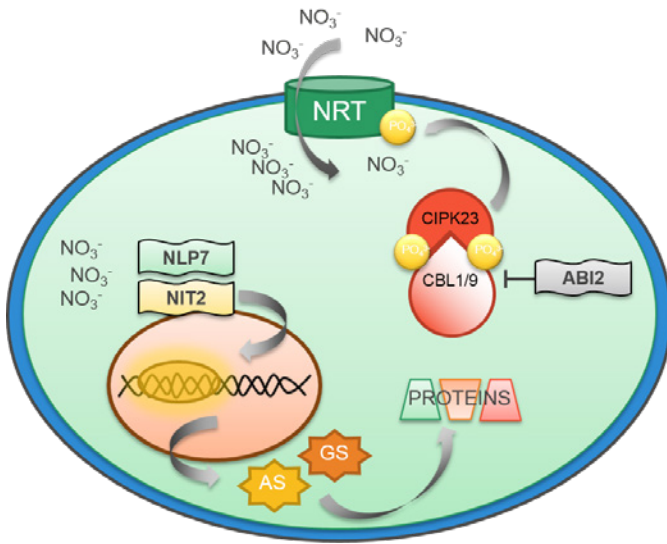

Overall Impressions

- This long-term project has resulted in some significant advances in pathway engineering. The improved strains require further characterization, trait stacking, and real-world testing. Future work on nitrogen regulatory responses and non-GMO Cas9 strategies could result in important advances. Future cytometry work is perhaps of less value, particularly if it is envisioned as a real-time cultivation diagnostic tool.
- Overall, continued improvement in the creation of genetic information on potential cultivation species is important. The project seems to have an understanding that taking things to scale will provide substantial information. Looking into the optimization of nutrient management and the increase of lipid accumulation through optimizing the nitrogen pathway shows forethought and the ability to create an impact at scale. The project seems to have developed a robust pipeline to generate cohesive results while taking information from the lab to scaled systems.
- Development and application of Cas9 techniques for genetic modification will significantly improve the chances of improved strains making it to commercial readiness.
- The overall objectives of this project are commendable and relevant to BETO, as understanding and engineering algal metabolism will likely be a key part of developing algae as an agricultural crop. This project suffers from a lack of focus and is not realistic regarding the magnitude of and potential challenges with the endeavor. Though the overarching ideas and goals presented are interesting and valuable, the lack of specific and clear targets and dearth of data included give the sense that this project is on track to overpromise and under deliver.
- The team is on track to make valuable contributions to expanding the molecular toolbox to include more methods (e.g., CRISPR Cas9) that need methodological improvements to work in algal systems. Work on understanding the genetic and metabolic basis for carbon partitioning is important for understanding the limitations on lipid production during the growth phase, which has implications for large-scale algal biomass production goals.

PI Response to Reviewer Comments

- We greatly appreciate the independent reviewers' insights into our research approach. These perspectives help us to focus on the identified important issues and direct resources to make the most significant improvements. Specifically, in the past year, we have refocused and consolidated our AOP portfolio into two main endeavors: flow cytometry physiological characterizations and genetic knock-out toolbox advancements. These will be applied to relevant BETO challenges for developing algae strains for enhanced productivity and improved robustness in the wake of environmental stress. These recent redirections have allowed us to complete the initial foundational work for both objectives and now quickly advance meeting the future milestones for strain improvements and performance testing. One strong, consistent message is the need to continue to push developed strains forward for extensive environmental testing at production-scale cultures.

One of our goals is to create a diagnostic toolbox, not only for the transgenic lines we are engineering, but also for use with other algal strains for rapid, high-throughput, single-cell analysis that other researchers will find useful. We had significant success in the first months developing these probes requiring experimentation for different strains, growth conditions, and physiological states. We now have functional protocols for three probes for two different strains achieved in the first quarter. Our goal is to have developed at least six total probes for different strains by the end of this AOP. These probes provide a significantly more comprehensive evaluation of cellular responses, thereby yielding more information to deepen our understanding of physiological responses. We agree that developing the real-time diagnostics will require methodology that is easily transportable to the field. However, to determine in-depth phenotypic characteristics, a robust, reliable, efficient, and user-friendly method-

ology is required. Thus, flow cytometry is the ideal method for these types of assessments. Protocols for phenotypic characterization in algae using appropriate flow probes that will not interfere with algal auto-fluorescence signals and will not undermine the fitness of the organism have not been developed to date.

We will continue to develop the molecular toolbox for *Nannochloropsis*, but are now directing efforts to design effective engineering platforms and protocols for applications to many algae strains. We have achieved significant foundational advancements, identifying many challenges but also recognizing overlap for optimization. The metabolic targets and expected response outcomes for our engineered pathways are conserved among species based on our genomic and bioinformatics analysis. Results from our studies can then be applied for broader impact across many algae species.

MULTI-SCALE CHARACTERIZATION OF IMPROVED ALGAE STRAINS

(WBS #: 1.3.2.102)

Project Description

The primary goal of this project is to generate improved algae strains and characterize their performance at multiple scales, from the bench to outdoors. By achieving this goal, this project aims to tackle two challenges. First, algal biofuel costs are highly sensitive to algae biomass and lipid productivity, but identifying or generating strains that have a productivity that is sufficiently high for profitable fuel production has been a challenge. Second, strategies for accurately down-selecting strains indoors, in an outdoor-relevant manner, require development. We specifically address these challenges by generating improved algae strains, testing them at multiple scales, and examining the metabolic changes responsible for the new phenotypes.

Recipient:	Los Alamos National Laboratory
Principal Investigator:	Taraka Dale
Project Dates:	10/1/2015–9/30/2018
Project Category:	Ongoing
Project Type:	AOP
DOE Funding FY 2014:	\$250,000
DOE Funding FY 2015:	\$350,000
DOE Funding FY 2016:	\$500,000
DOE Funding FY 2017:	\$600,000

We have three objectives: (1) Strain Improvement: use non-genetic modification strategies to improve strain productivity and robustness, including flow cytometry and adaptive evolution methodologies; (2) Strain Transition: develop and utilize strategies for transitioning our improved strains from laboratory flask experiments to outdoor ponds; and (3) Molecular Mechanisms: uncover the mechanisms by which sorted and adapted strains show improved phenotypes. Taken together, these ef-

Weighted Project Score: 6.8

Weighting: For ongoing projects, there is equal weighting across all four evaluation criteria: Approach, Relevance, Accomplishments and Progress, and Future Work.

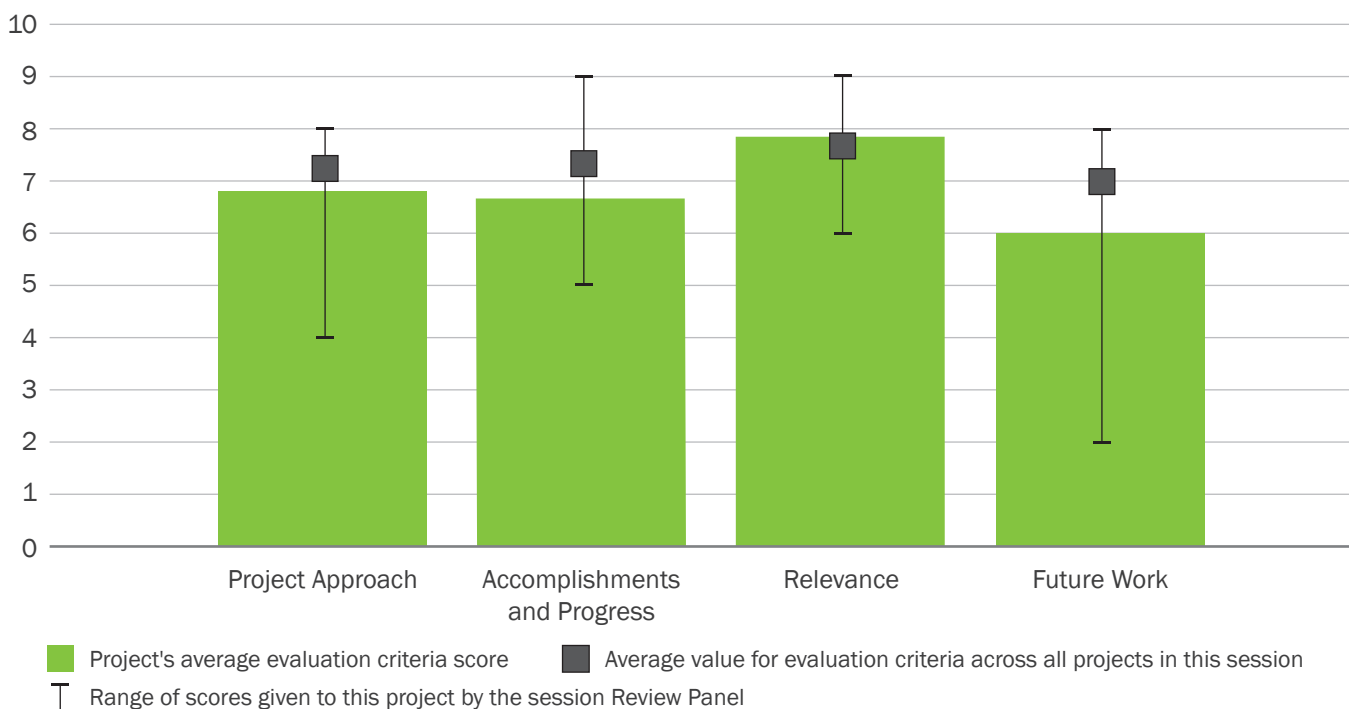

forts are generating improved strain phenotypes, as well as a better understanding of algae performance across scales, both of which will enable BETO to reach \$3/gge advanced biofuels.

Overall Impressions

- This project has shown significant ability in being able to sort for lipid concentration and separately for productivity. The work they are doing to down-select strains from in-door experiments and have the results translate to outdoors performance addresses issues that the industry has experienced. However, I think that having a goal of biomass accumulation instead of growth rate can be very misleading due to potential growth lag times.
- The project is focused on important questions of strain improvement and “flask-to-farm” issues. Some of the stated accomplishments require considerably more validation. Future plans are quite ambitious and may require a narrower focus.
- Overall, this is sound project with clear and relevant objectives. Integration of this project with others helps to standardize results relevant to the field. Clear and successful transition of lab-based assessment to field-scale pilot studies show a sound approach and well-thought-out pipeline for bio-feedback and relevant results.
- Very interesting work on productivity improvement, but I would like to see work at a scale larger than 1,000 L ponds to demonstrate that productivity improvements would hold as you move up in scale, as the project has demonstrated in moving from the lab to the field.
- Work conducted in this project is highly relevant for BETO and should be particularly commended for working with production strains and considering

applications of project outputs for algal production at scale. It is also effective at interactions with other national facilities and leveraging resources such as national testbeds. The overall technical approach would benefit from improving experimental design to increase confidence in the validity of strain improvements.

- This project addresses an important issue of utilizing advanced cell sorting and genetic tools to develop improved cell lines. If the project is able to overcome the transience of advanced phenotypes, the project has a strong platform to benchmark performance in a pipeline that spans the lab to the outdoor field conditions.

PI Response to Reviewer Comments

- Thanks to the reviewers for their thoughtful comments and general support of this work. We agree that ongoing validation is important for project success and aim to continue to do so. We agree that larger-scale data (greater than 1,000 L) would be relevant to collect. Should resources become available for such a task, we may pursue it; meanwhile, we will leverage similar work conducted at the testbed facilities and by our industry collaborators. Regarding validation of the improved strains and transience of phenotype, we have noted multi-year stability of improved phenotypes, in the lab for multiple strains and up to the 1,000 L scale for the one strain tested with that particular question in mind. We could have communicated this more clearly, as well as our onboarding of mutagenesis strategies to isolate even more stable phenotypes, which we did not have time to discuss but is ongoing. We take the reviewer’s point regarding productivity calculations and will be extensively characterizing the new improved-growth phenotypes to better understand the impact on relevant productivity measurements.

ALGAE BIOTECHNOLOGY PARTNERSHIP

(WBS #: 1.3.2.103)

Project Description

The commercial viability of algal biofuel pursuits requires improved biological productivity across the entire value chain, which comprises a function of growth rate, biomass accumulation capacity, and a robust biosynthetic capacity for target molecules. Additional characteristics related to sustainability and deployment, such as tolerance to a wide range of salt concentrations and temperatures, must also be considered. To this end, the Algae Biotechnology Partnership aims to identify novel, halotolerant algal strains with productivity superior to current SOT strains, suitable for outdoor deployment in saline water as summer and winter crops. We are targeting the development of broad-host-range genetic tools in these halotolerant strains in an effort to achieve the level of development seen in the top-performing fresh-

Recipient:	National Renewable Energy Laboratory
Principal Investigator:	Michael Guarnieri
Project Dates:	10/1/2015–9/30/2018
Project Category:	Ongoing
Project Type:	AOP
DOE Funding FY 2014:	\$0
DOE Funding FY 2015:	\$300,000
DOE Funding FY 2016:	\$200,000
DOE Funding FY 2017:	\$500,000

water strains. To date, we have successfully screened, isolated, and characterized a series of halotolerant algal strains with exemplary productivity metrics, validated strain productivity in outdoor ponds, and developed baseline genomic and genetic tools for targeted strain engineering pursuits. Importantly, these strains have demonstrated productivity superior to BETO 2016 SOT metrics. This work directly targets identified BETO MYPP barriers, including feedstock availability and cost, sustainable production, and feedstock genetics and development.

Weighted Project Score: 7.3

Weighting: For ongoing projects, there is equal weighting across all four evaluation criteria: Approach, Relevance, Accomplishments and Progress, and Future Work.

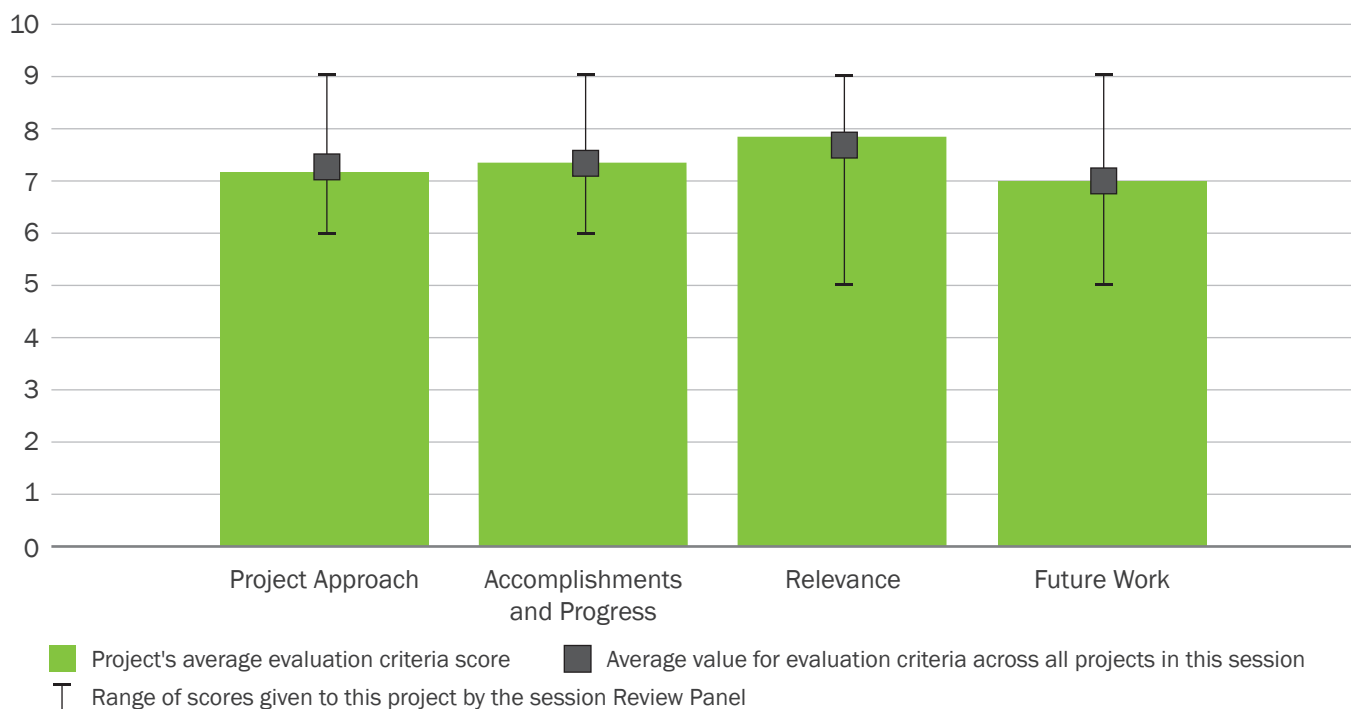

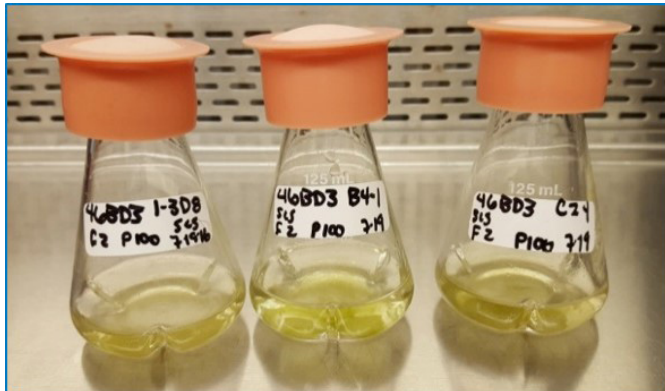

Overall Impressions

- This project is working on finding strains that can grow in adverse, non-fresh-water environments and are suitable for typical downstream processing. The work to develop a high-productivity strain is relevant to the industry and meeting MYPP goals. To this point, the work has been done partially indoors and/or batch systems. The future work to enable targeted strain engineering to improve the productivity and demonstrate in outdoor ponds is appropriate for their presented plan.
- Strain screening and characterization has identified some promising-looking salt tolerant strains with high productivity and suitable compositions. Genetic toolbox development is making good progress. More complete characterization should be forthcoming. The future plans for the project as presented were quite vague, especially for FY 2018.
- Overall, this project has substantial merit and potential for the discovery of higher-productivity microalgae species. Integration of simulated outdoor screening blends well with the ability to transition for lab to field pilot-scale data collection.
- Advanced genetic tools (especially newly developed CRISPR technology) for algae will be important for advancing toward productivity targets and improving strain robustness.
- Screening several halotolerant algal strains for modest improvements in productivity relative to SOT is a key accomplishment of this project to date. Regarding genetic tool development, this project is ambitious at the risk of being somewhat unfocused. Beneficially, this project leverages core capabilities of several partner institutes and has effectively utilized testbed facilities (ATP3).
- This project couples strain improvement efforts with scale-up and testing in outdoor ponds. Results to date include identification of several fast-growing strains and demonstrated performance above a benchmark strain under several conditions and scales. Identification of fast-growing, halotolerant strains will have clear relevance to industry and BETO goals if successful.

PI Response to Reviewer Comments

- We thank the Review Panel for their encouraging and constructive critique. We are optimistic that our progress to date to identify high-productivity halotolerant algal strains and develop associated genetic and genomic toolkits represents a critical advancement for the BETO algae portfolio and the larger algal research community as a whole. We look forward to continued efforts to enhance productivity in top-candidate strains via the further development of robust genetic and functional genomic tools.

BREEDING ALGAE FOR LONG-TERM STABILITY AND ENHANCED BIOFUEL PRODUCTION

(WBS #: 1.3.2.104)

Project Description

With molecular-assisted breeding, great strides have been made in developing higher-yielding and more robust crops. To date, however, these techniques have not been applied to commercial strains of algae for crop improvement. This has been due to a lack of understanding of the genomics and reproductive life cycles of algae. Recently, we and collaborators completed the genome annotation of three independent isolates of the commercial algal production strain *Chlorella sorokiniana*. We discovered tremendous genetic diversity in these strains and the presence of genes involved in meiosis and encoding the flagellar proteins required for mating. Thus, the potential to use molecular-assisted

Recipient:	Los Alamos National Laboratory
Principal Investigator:	Richard Sayre
Project Dates:	10/1/2016–9/30/2017
Project Category:	New
Project Type:	AOP
DOE Funding FY 2014:	\$0
DOE Funding FY 2015:	\$0
DOE Funding FY 2016:	\$0
DOE Funding FY 2017:	\$150,000

breeding strategies for algal improvement exists. Over the first quarter of the project, we have developed conditions to induce breeding in *Chlorella sorokiniana*, as well as demonstrated induction of the flagella following meiosis and cytoplasmic exchange. We have developed a novel genetic transformation system to introduce genetic markers to track mating events and saturated the three genomes with genetic markers spaced on average 37 kilobase apart. Next, we will demonstrate generation of new recombinant lines and backcross these lines to

Weighted Project Score: 7.9

Weighting: Approach–25%, Relevance–25%, and Future Work–50%.

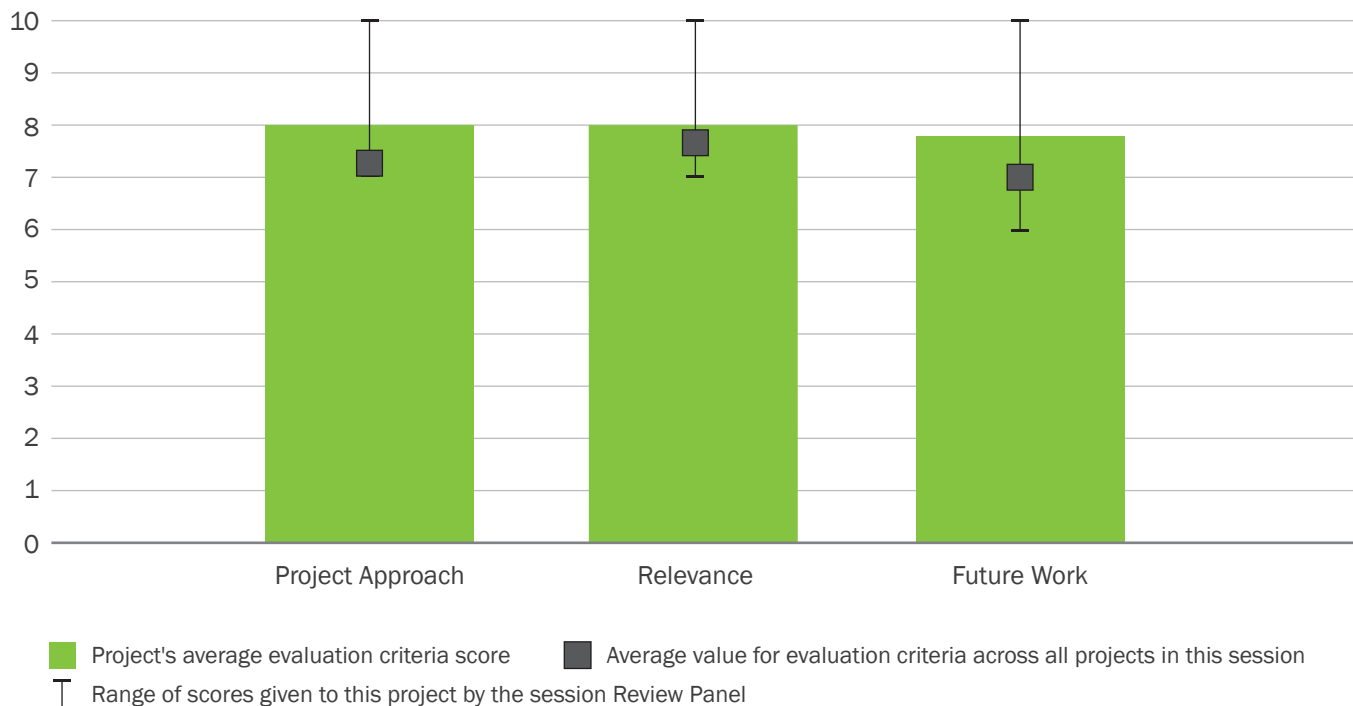

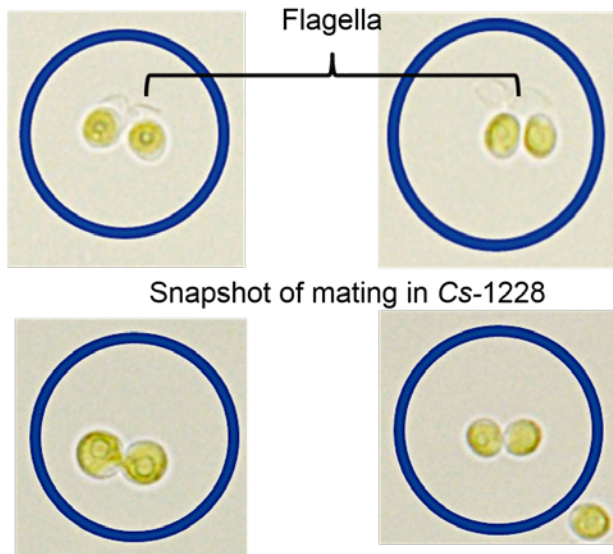

develop stable inbred lines. Longer-term goals are to select for traits of interest and to map the genes conferring those traits. The toolkits developed through this project will be made available to the community.

Overall Impressions

- Molecular-assisted breeding systems are being developed for a promising green algal strain. The success of such systems in higher plant improvement, and the fact that resulting strains would be non-GMO, makes this a worthwhile option to pursue. The species specificity of the approach is one downside, but methods developed could benefit others.
- This project employs a somewhat different approach than that of the other genetic manipulation projects, which I find to be very interesting. The stated goals of this approach try to lend the practices of what

was done in conventional agriculture to that of the current algae farming industry. Though the project does have some challenges with deploying these strains and maintaining these improvements through the breeding process, it could be a step in the right direction.

- Great advancement in breeding systems—marker assisted for trait fixation and work on sterility systems is critical for progress in improved strains for production.
- Understanding algal reproduction is essential to harness potential (introduction of stable traits) and mitigate potential problems (trait loss in production settings). Most studies aiming to improve strains for large-scale biomass production don't consider the potential benefits and problems associated with algal breeding in a production setting, and researchers should be commended for developing a strategy to investigate the potential with this project.
- With a single year of funding, this project is on track to make significant accomplishments that could lead to methodologies that are widely applicable in the algae community. The rigorous approach to developing stable lines could help modernize algae breeding efforts, which appears to be a gap in the algal industry today.

PI Response to Reviewer Comments

- We thank the reviewers for their efforts and helpful comments.

MAJOR NUTRIENT RECYCLING FOR SUSTAINED ALGAL PRODUCTION

(WBS #: 1.3.2.200)

Project Description

A consortium of researchers from SNL, Texas A&M AgriLife Research, and Open Algae have developed a novel, cost-effective, and efficient remineralization process to convert organic forms of nitrogen and phosphate present in algae to chemical forms that can be liberated from the harvested algal biomass, then readily captured and returned to algal mass culture systems, and that are capable of supporting algal growth. We have developed methods for the rapid remineralization of up to 70% of the cellular phosphate from osmotically shocked, non-denatured algal biomass using endogenous enzymes under a range of relatively mild incubation conditions. Our phosphate remineralization process, which we have demonstrated at both laboratory and pilot-pond scale,

Recipient:	Sandia National Laboratories
Principal Investigator:	Todd Lane
Project Dates:	10/1/2013–9/30/2016
Project Category:	Sun-setting
Project Type:	FY 2012—Advancements in Sustainable Algal Production (ASAP): DE-FOA-0000615
Total DOE Funding:	\$2,145,126

supports equivalent algal growth and does not contain any growth inhibitory compounds, as evidenced by multiple sequential cycles of growth and nutrient remineralization. We have also demonstrated the remineralization of approximately 60% of cellular nitrogen through the fermentative conversion of amino acids to ammonium. We have precipitated re-mineralized phosphate and ammonia through the formation of struvite and demonstrated growth of algae on these recaptured nutrients. Finally, we have demonstrated the potential to integrate

Weighted Project Score: 7.0

Weighting: Approach–25%, Relevance–25%, and Accomplishments and Progress–50%.

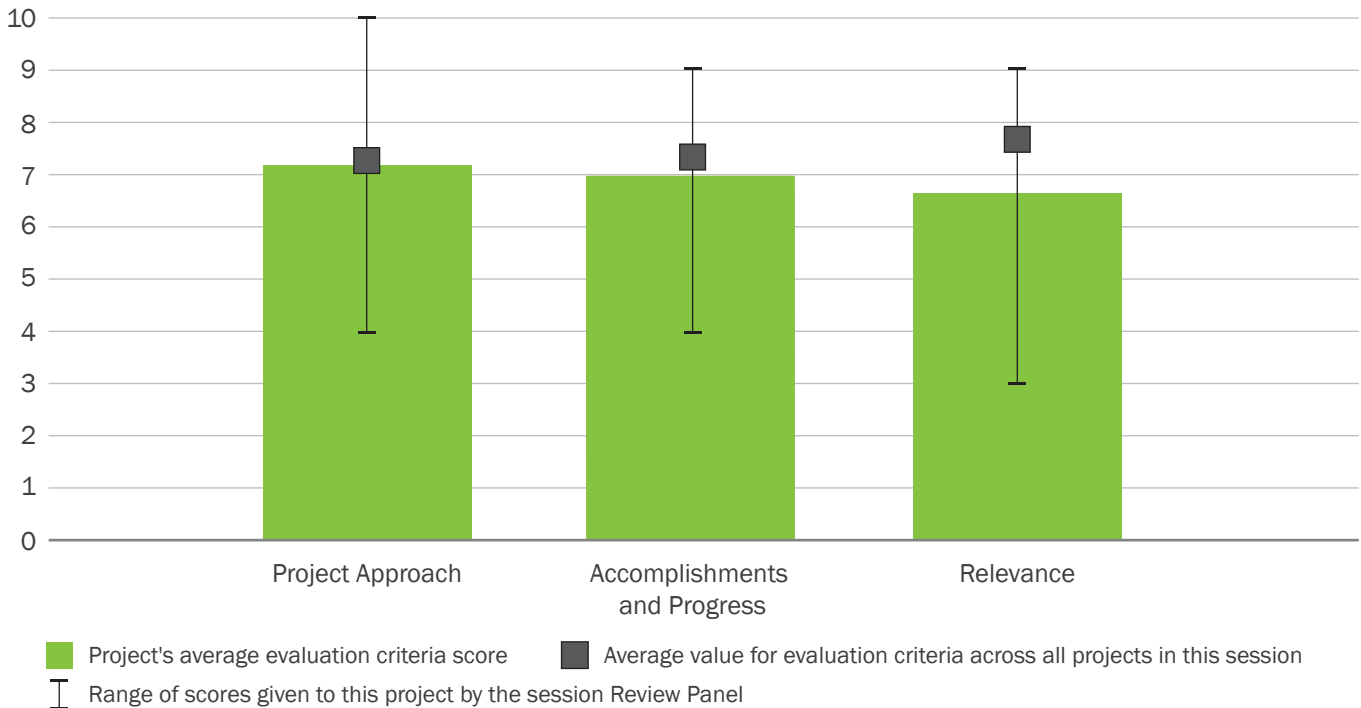

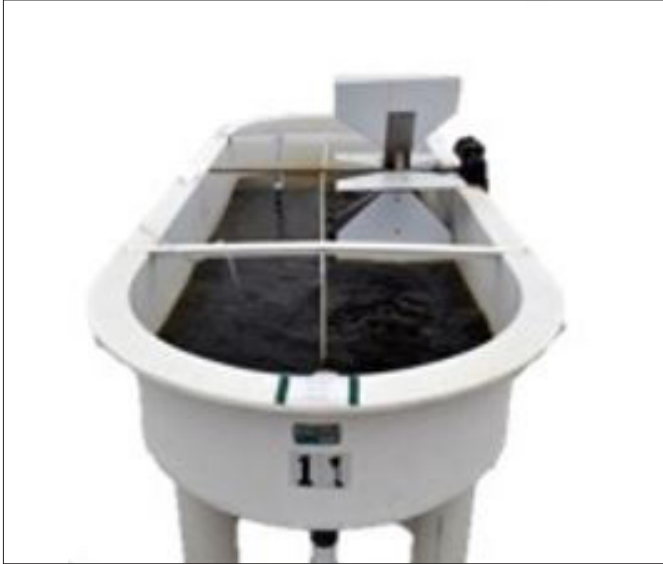

our nutrient recycle protocols with biomass processing methods, such as those for the extraction of neutral lipids.

Overall Impressions

- Excellent presentation. The goals, methods, and conclusions were clearly communicated and to the point. This is a well-focused project with clearly stated results and conclusions. I appreciate the work done to demonstrate the results from bench scale to out-of-doors. The project demonstrated a feasible method for recycling phosphorus and the majority of nitrogen. Additional work to determine the economics of this approach may be warranted.
- This project was an important demonstration of a mechanism for recycling nitrogen and phosphorus

to enhance the sustainability and economic viability of algal biofuels. This is particularly critical work given potential global phosphate supply limitations. Though perhaps somewhat “dated” now, the goals of the project were achieved, including a demonstration of biological accessibility. Integration with TEA should have been discussed.

- Overall, the recycle of nutrient stream back to the main production systems has significant value. The main issues may relate to how this process scale and integrates itself into the larger-scale production system in a cost-effective manner. Value may be found for the resale of recovered nutrients as a potential co-product.
- This project demonstrated promising results for nitrogen and phosphorus recycling and should be continued—particularly the work around struvite.
- Nutrient recycling efforts have a clear link to BETO priorities for resource use efficiency, and the presenter articulated a clear rationale for a need for phosphorus use efficiency in general terms. It is unclear if this project would have relevance to large-scale algae production.

PI Response to Reviewer Comments

- We would be happy to continue work should additional resources become available to address the TEA, engineering, and marketing issues that were not in the scope of the original project.

INTEGRATION OF NUTRIENT AND WATER RECYCLING FOR SUSTAINABLE ALGAL BIOREFINERIES

(WBS #: 1.3.2.202)

Project Description

Our project has focused on isolating and characterizing high-productivity microalgae strains that thrive in alkaline conditions. The microalgae are cultivated under conditions that simultaneously provide (1) a high pH (approximately 10.2) to effectively scavenge atmospheric CO₂, and (2) a high alkalinity (greater than 100 milliequivalents) to maintain high, non-limiting bicarbonate concentrations (greater than 30 millimolar) for photosynthetic carbon fixation. Under these growth conditions, we have demonstrated sustained high productivity (approximately 20 g/m²/day) of strain SLA-04 under outdoor conditions, even in the absence of supplemental CO₂ input. Furthermore, in 2 years of outdoor experi-

Recipient:	University of Toledo
Principal Investigator:	Sridhar Viamajala
Project Dates:	2/1/2013–8/31/2016
Project Category:	Sun-setting
Project Type:	FY 2012—Advancements in Sustainable Algal Production (ASAP): DE-FOA-0000615
Total DOE Funding:	\$2,999,934

ments, the cultures resisted detrimental contamination and culture “crashes,” likely due to the high pH values. Finally, we demonstrated that the cultures grow well in fresh water, high salinity waters, and with a low input of synthetic fertilizers. The resulting low-N-content biomass (approximately 3%) is favorable for biofuel production due to the higher relative proportion of carbohydrates and lipids. Our project has thus addressed cultivation challenges related to (1) sourcing limitations and high cost of CO₂ delivery, (2) high culture productivity while maintaining culture stability, and (3) mini-

Weighted Project Score: 5.0

Weighting: Approach–25%, Relevance–25%, and Accomplishments and Progress–50%.

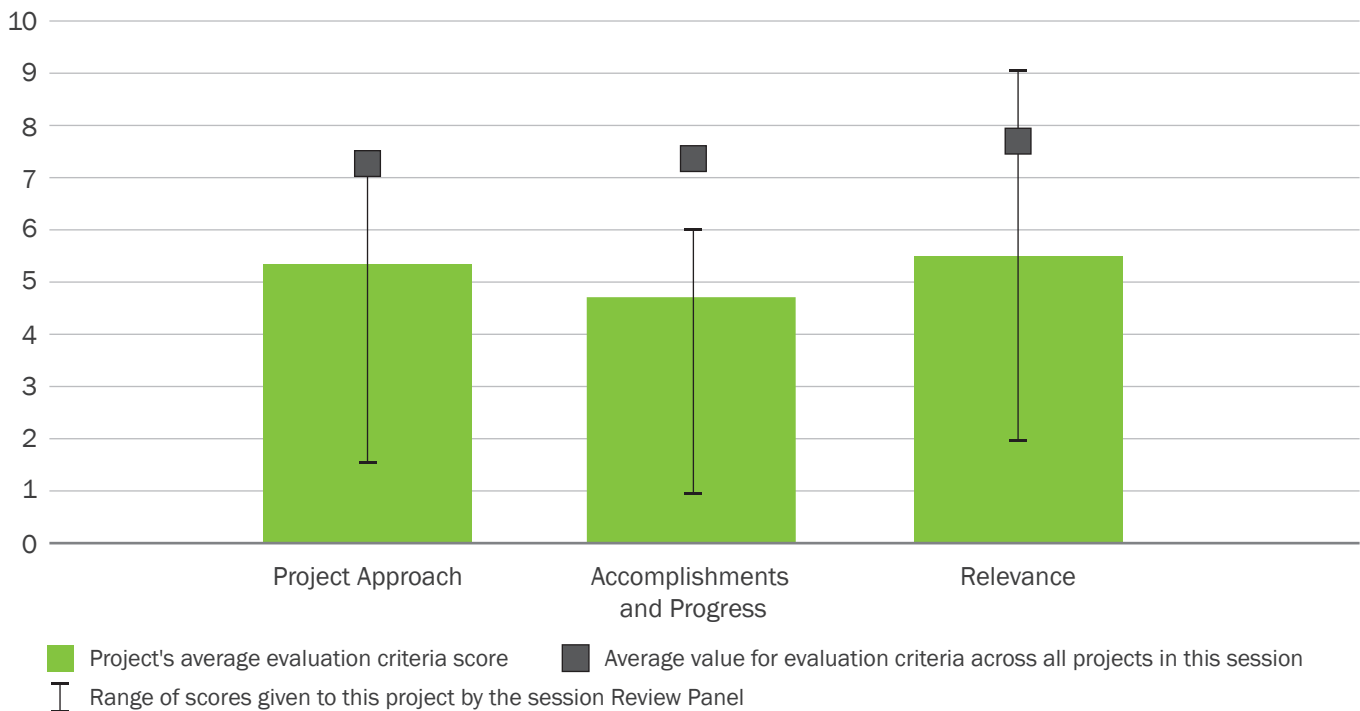

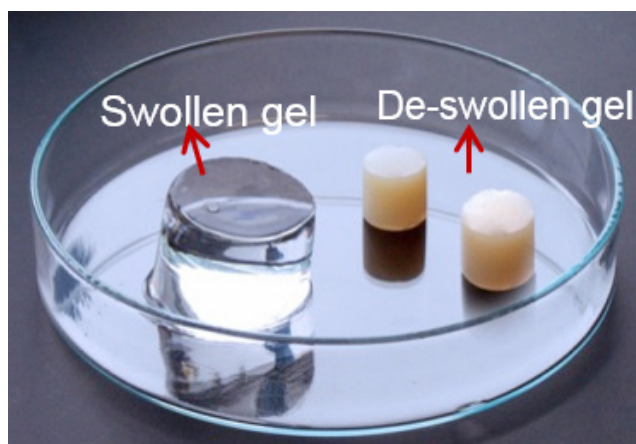

mization of nutrient inputs. We have also developed and tested novel “smart hydrogel”-based solid-liquid separations that allow for low-energy harvesting and effective water recycle without chemical contamination.

Overall Impressions

- The cultivation studies performed as part of this project have produced some unexpectedly high productivities while relying only on CO₂ transport from the atmosphere. It is my understanding that these tests occurred over the time frame of 4 to 8 days. To validate the results, it would be beneficial if the investigators would increase the testing period to several months. The use of hydrogels is an innovative approach for dewatering. The hydrogels should be tested to see what effect media contaminants have on the gel performance and a TEA prepared to explore potential commercial uses or limitations.
- The project explored two approaches that touch on critical limitations of algal biofuels production (CO₂ cost and pond siting, culture stability, and dewatering efficiency). Results are promising when taken at face value, but were not convincingly presented.
- The reduction of needed CO₂ for the operation of a large-scale system does have merit. Decoupling the sites from co-location lends to the possibility of more attractive siting opportunities. There are potential issues with the overall scaling of this system

with site-specific water sources causing precipitation issues due to the heavy loads of bicarbonate, which in turn could increase the overall operating costs.

- This is an interesting project, but there are many issues with how experiments were conducted (i.e., length of growth trials) relative to the conclusions drawn.
- Conceptually, cultivating algae at high pH/alkalinity is beneficial for both CO₂ delivery and crop protection. This project provides data demonstrating that high productivities can be obtained in a high pH/alkalinity system, which is one of the most important findings from this work. Few publications have resulted directly (yet), and the effort could be more productive.
- This project addresses high-priority issues of improving productivity, culture stability, and low-cost dewatering through a targeted set of technologies (high pH growth and hydrogel dewatering). Results appear promising, but the short-term nature of the experimental approach and the lack of economics for the dewatering approach make it unclear how results will be used by the broader community.

PI Response to Reviewer Comments

- We thank the reviewers for their careful review of our project and acknowledgement of its many strengths. The reviewers also expressed some concerns, which are addressed below.
 - Duration and scale of growth experiments: The scope of our project is to develop fundamental science and engineering-based solutions to some of the critical challenges associated with microalgae cultivation—high cost of CO₂ supply and frequent culture crashes. As such, using first-principles mass transfer models coupled with aquatic inorganic carbon chemistry, we assessed that a

high pH and high alkalinity media would allow high-productivity microalgae cultivation without concentrated CO₂ inputs. The high pH media would also mitigate frequent predator infestation. Conceptual validation of this approach was achieved through outdoor pond cultivations at 30 L and 1,000 L scales. As correctly pointed out by the reviewers, the next steps would be pilot-scale studies to address (1) scale-related issues, if any; and (2) long-term culture performance. We have ongoing work to complete longer-term studies (of 3-month duration), and we anticipate that these will be completed by the end of July 2017 (before the end date of the project).

- Potential for precipitation: We agree with the reviewers that precipitation of carbonates can become a concern in high carbonate alkalinity media. Until now, the team has not observed significant issues with precipitate formation since pH values, carbonate concentrations, and

multi-valent cation concentrations will have to be high for carbonate (e.g., calcium carbonate) precipitation to occur. Geochemical modeling using MINTEQA2 and PHREEQC have been accompanying the work, and we continue to be vigilant regarding the possibility of mineral precipitation having an impact on the potential of the high-alkalinity culturing approach.

- Publications: Two patent applications (one provisional and one utility) and one publication have been submitted, describing aspects of the high-pH and high-alkalinity cultivation and hydrogel harvesting. The bulk of the work on this aspect of our project has only recently been completed (and some work is still ongoing), and additional manuscripts are under preparation for submission.
- TEA of hydrogel harvesting: This has been addressed in (1) a recent publication from our group,¹⁹ and (2) a recent master's thesis.²⁰

¹⁹ Adam M. Hise, Gregory W. Characklis, Jordan Kern, Robin Gerlach, Sridhar Viamajala, Robert D. Gardner, and Agasteswar Vadlamani, "Evaluating the Relative Impacts of Operational and Financial Factors on the Competitiveness of an Algal Biofuel Production Facility," *Bioresour. Technol.* 220 (2016): 271–281.

²⁰ Adam Hise, "Interdependence of Financing Parameters and Processing Improvements in the Design of Economically Competitive Algal Biofuel Production Pathways" (master's thesis, University of North Carolina at Chapel Hill Graduate School, 2015), <https://cdr.lib.unc.edu/record/uuid:981f952c-f518-4f0f-ad25-599178aaaf8a>.

CONTINUOUS BIOLOGICAL PROTECTION AND CONTROL OF ALGAL POND PRODUCTIVITY

(WBS #: 1.3.2.300)

Project Description

A team of researchers that brings together complex microbial community analyses (Lawrence Livermore National Laboratory), cutting-edge algal monitoring (Sandia National Laboratories), a leading commercial algal company (Heliac Inc.), and techno-economic modeling (University of California, Davis) are developing protective bacteria for crop protection that will increase algal pond stability and improve predictability and annual yield. Pipeline development to identify probiotic species and conditions will also provide a path forward for translating microbiome work from bench scale to process development. While causative pests in pond crashes often are unknown, grazing in general is estimated to result in a 20% loss in biomass productivity

Recipient:	Lawrence Livermore National Laboratory
Principal Investigator:	Michael Thelen
Project Dates:	10/1/2015–9/30/2018
Project Category:	Ongoing
Project Type:	FY 2015—Targeted Algae Biofuels and Bioproducts (TABB): DE-FOA-0001162
Total DOE Funding:	\$695,000

annually. By targeting common culprits of ponds crashes, we estimate that, at minimum, a 5%–10% increase in annual yield is possible if our goal is achieved. To date, we have developed assays to determine grazing and parasitism rates of model pests (rotifers and chytrids) and set up a screening pipeline to identify novel probiotic consortia and isolates that decrease these rates. We have demonstrated isolates and consortia that decrease grazing rates under variable bench-scale conditions, and we profiled an industrial system microbiome over an entire year to identify conditions for optimal probiotic application.

Weighted Project Score: 8.0

Weighting: For ongoing projects, there is equal weighting across all four evaluation criteria: Approach, Relevance, Accomplishments and Progress, and Future Work.

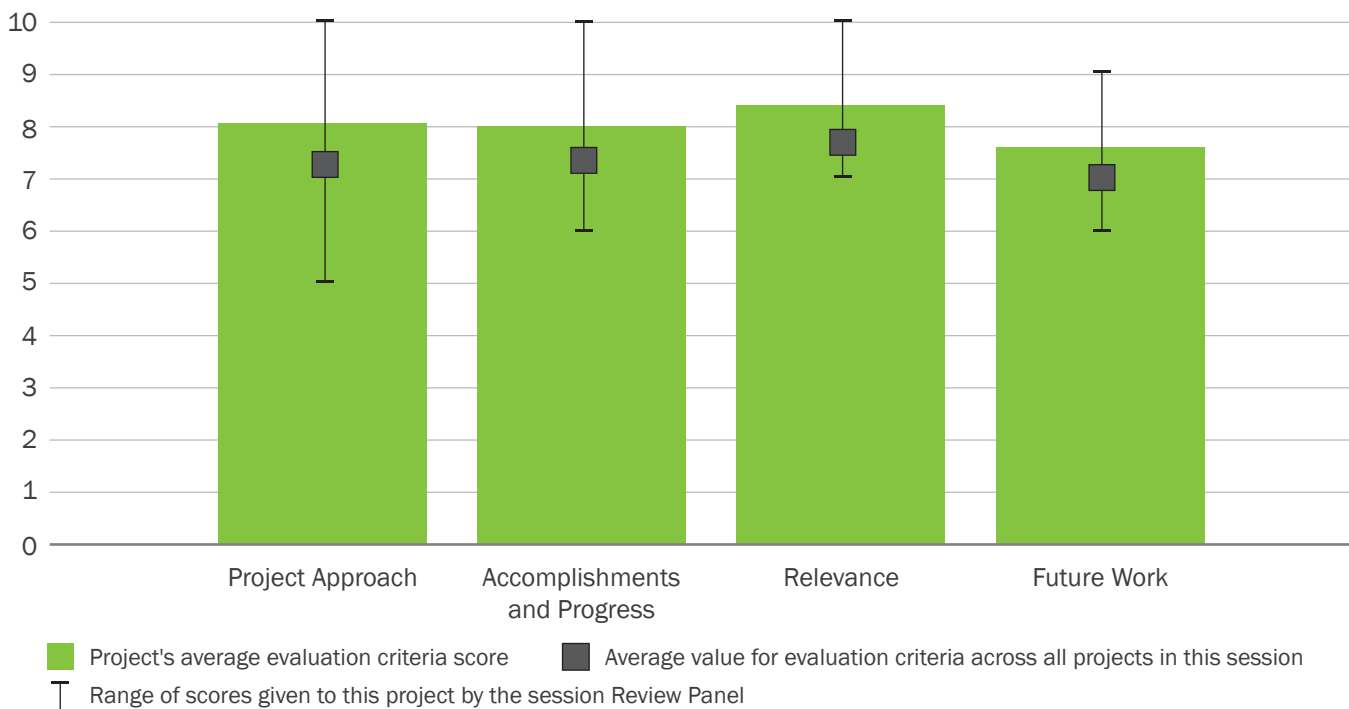

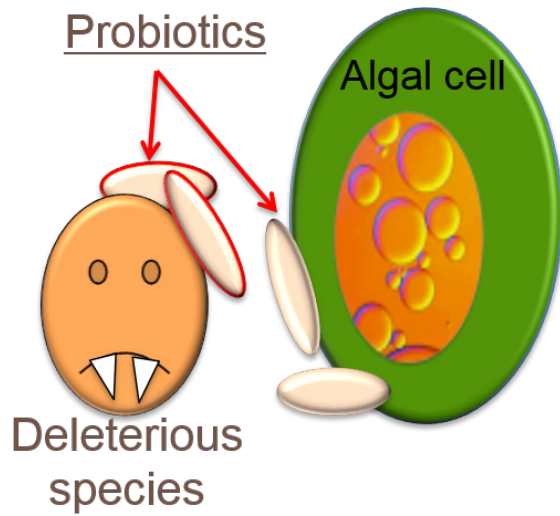

Overall Impressions

- This project is good initial work for determining the potential protecting properties of probiotic bacteria. Future work should include the ability to sustain the effects long term. The long-term effects may be very complicated to control and predict as a pond's susceptibility to pests can be due to accumulative stress factors, which makes determining a solution complex. The future work will include a TEA, which should be revealing. I appreciate the scale-up to commercial size this project will use to test their conclusions.
- The investigators have developed powerful tools to screen for probiotic bacteria for crop protection. This is a very valuable approach and has already yielded promising bacterial candidate strains. The microbial community interactions that will be revealed through this work will be of fundamental scientific interest, but also will have practical implica-

tions for increasing real-world algal productivities. It is important to include studies to assess bacterial effects on productivity with no predation challenge. Elucidating the protective mechanisms would be an important contribution if the project scope allows.

- Overall, this project is an innovative approach that could show significant value moving forward. Though there may be some issues with the ability to apply this at scale due to regulatory and co-product issues, this project could provide a new and innovative way to combat pond predation and improve overall crop productivity.
- This project demonstrates the potential of non-chemical crop protection of outdoor raceway ponds and the importance and potential leveraging of the microbiome of an algal culture. Alternative crop protection methods are required to move the industry to the scale needed for the MYPP. However, the methods must be deployable at scale and cost-effective.
- The team presented a clear rationale for the project, and the technical approach appropriately addresses interaction between scales. A TEA was integrated through the team's efforts. The team appears to be on track, and future work is clearly aligned with the original work plan. This project is highly relevant, as pond stability is absolutely critical to all long-term BETO MYPP productivity and cost targets.

PI Response to Reviewer Comments

No official response was provided at the time of report publication.

INTEGRATED PEST MANAGEMENT FOR EARLY DETECTION ALGAL CROP PRODUCTION

(WBS #: 1.3.2.310)

Project Description

Large-scale, outdoor algal biomass growth, production strain(s) are subject to attack by pathogens, predators, and non-productive competitors. This project focuses on the early detection and identification of pests with the intent of guiding the best practices for prevention and control. An automated mass spectrometry-based crop protection monitoring system coupled with quantitative polymerase chain reaction/high-resolution melt analysis that will be integrated into existing environmental control systems is under development. These systems will enable robust biomass production through automat-

Recipient:	University of California, San Diego
Principal Investigator:	Robert Pomeroy
Project Dates:	10/1/2015–3/31/2019
Project Category:	Ongoing
Project Type:	FY 2015–Targeted Algae Biofuels and Bioproducts (TABB): DE-FOA-0001162
Total DOE Funding:	\$760,725

ed, early, and potentially pest-specific crop protection and will greatly reduce the costs and labor associated with current monitoring systems and resultant losses of valuable biomass from contaminations. The project has encountered problems related to sample collection and strain purification. To date, we have a mass spectrometry-based platform that has shown promising results as an early detection system; a cataloging of molecules specific to prey-predator interactions, both in the head

Weighted Project Score: 7.5

Weighting: For ongoing projects, there is equal weighting across all four evaluation criteria: Approach, Relevance, Accomplishments and Progress, and Future Work.

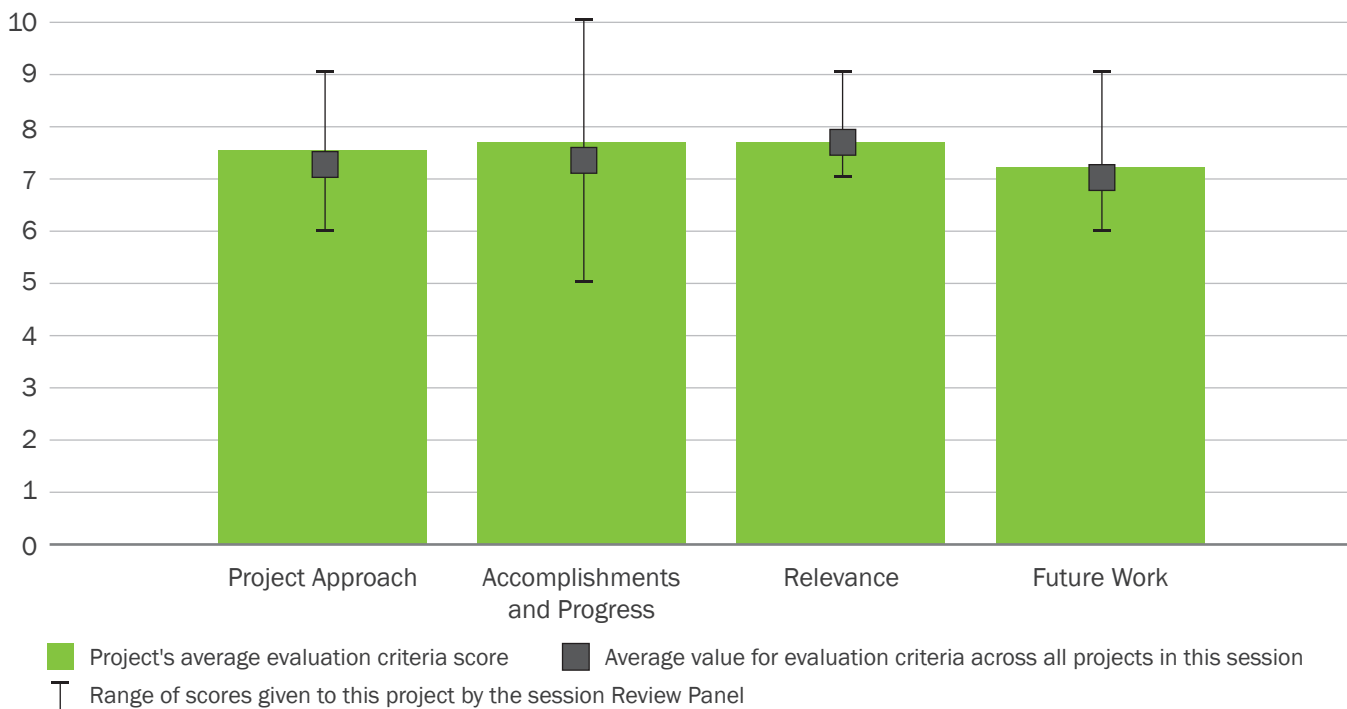

space and bulk liquid has been collected and will be expanded; a Chemical ionization mass spectrometry capable of continuous monitoring is in development; a set of primers has been optimized for quantitative polymerase chain reaction/high-resolution melt as a simple closed-tube method of class/species identification; the techno-economic impact of this platform is underway; and intellectual property in the form of chemical marker identification, primer sequences, and new application-specific instrumentation is in development.

Overall Impressions

- Interesting project and detection method for determining if a pond is being stressed by predation. I would like to see a more detailed plan on how this system would be deployed in a commercially sized field, along with costs and operations plans. I think it will be difficult to quantify the benefit of this approach in a TEA. However, the early detection seems intuitively to be a good idea.
 - The sensitivity of the approaches being used should allow for significantly earlier detection of upcoming culture crashes. If appropriate intervention strategies are available, this should lead to reductions in the number and length of downtimes. This is early-stage research and could elucidate specific markers for various biotic challenges. However, it is not clear how this will transition into a low-cost, field-deployable detection system (i.e., “simple, automated, affordable, and robust technologies”).
 - Overall, this is a very interesting and forward-thinking project. Though the described system at scale may not be feasible for deployment due to various complications with maintaining and the costs of installing specific high-cost infrastructure, the premise of the project could have a dramatic impact on the ability to maintain crop integrity and stability moving forward. The concept of this project may find a better deployment option as the system is tested and costs are considered at scale.
- Novel approach to pest detection that seems reasonable for field deployment; it could be used by field operators in real time (depending on prototype), or, depending on the cost of infrastructure, put online for real-time monitoring. This would enable early detection of pests, which is critical for crop stability and productivity improvements.
 - Significant progress has been made during this project toward understanding the biology of predator-mediated pond crashes, which is critical knowledge necessary to develop systems aimed at early detection. Additionally, investigators have shown the economic value of early intervention through the use of TEA, making this work directly applicable for industry and increasing relevance. Knowledge gained from this project has the potential to contribute significantly toward production at scale, and future work should focus on developing industrially relevant prototypes.
 - Improving detection sensitivity for pond crashes has clear relevance to mitigation strategies for maximizing uptime. The team presented a nice TEA to quantify the advantage of early detection, and the technology also may have applications in adjacent industries. It is unclear how the technology in its current form would be deployed in a large-scale algae farm, but the approach could be used for low-cost sensor development in the future.

PI Response to Reviewer Comments

No official response was provided at the time of report publication.

ALGAE PRODUCTION CO₂ ABSORBER WITH IMMOBILIZED CARBONIC ANHYDRASE

(WBS #: 1.3.2.320)

Project Description

GAI is a leader in low-cost algae production technologies. A suite of advances in open pond algae growth is being developed to achieve commercially viable production of oil and high-protein meal. An essential part of GAI’s production method is the efficient and economical capture, storage, and distribution of CO₂ from power plant flue gas to the actively growing algae, ensuring an ample supply of CO₂ for photosynthesis. GAI has operated a large-scale open raceway algae cultivation system with all of the CO₂ supplied from power plant flue gas for the past 3 years. An advanced flue gas CO₂ supply method, which incorporates an absorber and carbonate shuttle, overcomes the permitting and engineering/cost limitations of other state-of-the-art approaches.

Recipient:	Global Algae Innovations Inc. (GAI)
Principal Investigator:	David Hazlebeck
Project Dates:	7/1/2016–7/1/2019
Project Category:	Ongoing
Project Type:	FY 2015—Targeted Algae Biofuels and Bioproducts (TABB): DE-FOA-0001162
Total DOE Funding:	\$900,000

The objective of this project is to further improve the efficiency of this CO₂ supply method. The goals are to achieve 80% CO₂ capture efficiency and 90% carbon utilization efficiency in integrated operation of a high-efficiency absorber with open raceway algae cultivation. This project will improve the efficiency of GAI’s proven system for utilizing power plant flue gas to supply CO₂ to large-scale open raceway cultivation, which is important to BETO objectives because low-cost CO₂ is necessary to achieve algal biofuel cost metrics, and high CO₂ capture and utilization efficiency are necessary to achieve biofuel life-cycle and production potential metrics.

Weighted Project Score: 8.3

Weighting: For ongoing projects, there is equal weighting across all four evaluation criteria: Approach, Relevance, Accomplishments and Progress, and Future Work.

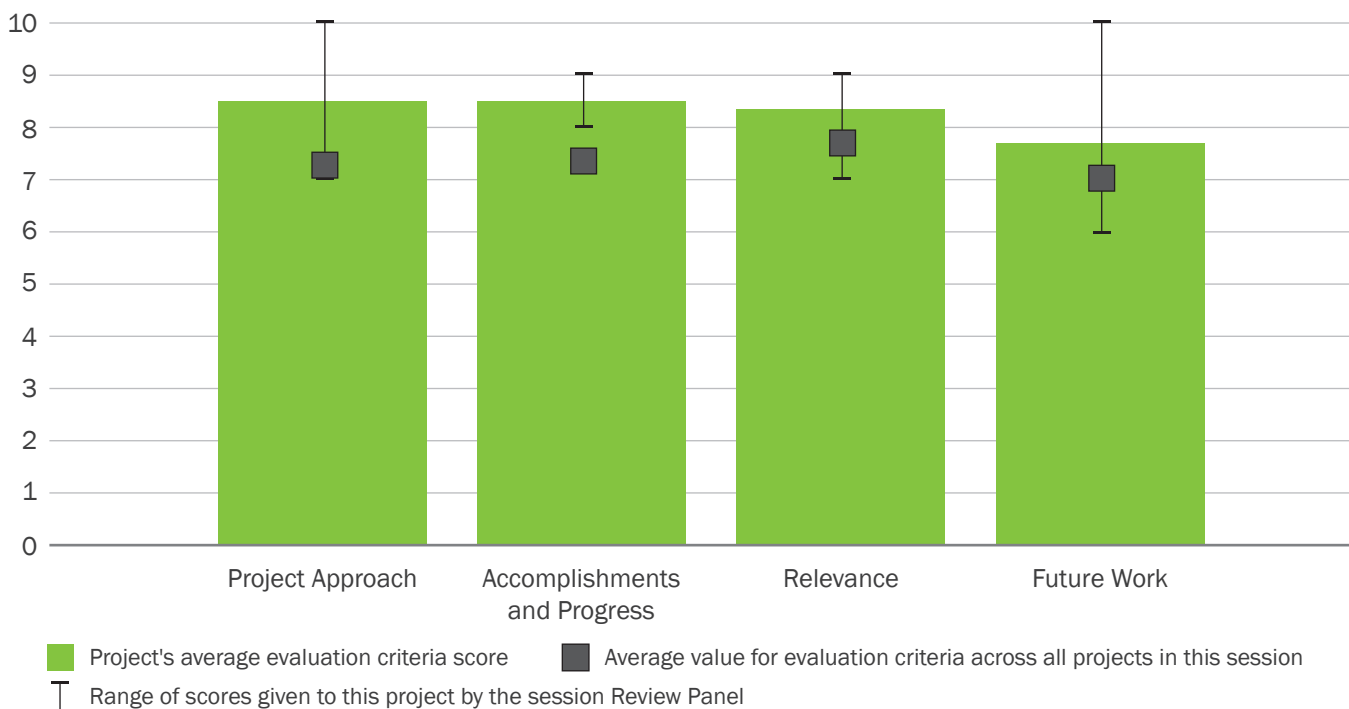



Overall Impressions

- Very innovative approach to use enzyme to speed the absorption of CO₂ into the media. While this approach is being investigated by others, this project will test, and hopefully improve, its robustness in an actual industrial application. Great job.
- GAI is taking a novel approach to issues around carbon delivery that many had not perceived as issues, but compelling arguments are presented to support the value of such an approach. The concept has the potential to reduce capital and operation expenditures around flue gas delivery to ponds. Good progress has already been made. Hopefully the economic case for (or against) this approach will be made available at some point to the greater community.
- Overall, this project has made significant progress in the completion of its deliverables. Utilizing a system of this nature provides the opportunity to reduce loss of conventional CO₂ injection systems currently

used by industry. These advancements can and will have a significant impact on the industry.

- This project is highly relevant—growing algae exclusively on flue gas at over 5 acres for 3 years and developing commercially deployable technology to advance the industry.
- This straightforward and worthwhile project is aimed at developing technologies to improve sustainability and reduce the cost of producing fuel from algae at scale. It is particularly constructive to work to address engineering challenges (such as the capture and delivery of CO₂) in a facility involved in all aspects of production.
- Large-scale deployment of algal biofuels depends on high CO₂ utilization efficiency, and the proposed approach appears to result in large efficiency improvements compared to gaseous approaches in neutral-pH, unbuffered media. Strong progress toward technical targets was reported for carbon use efficiency and cost of CO₂ capture. The project appears ahead of schedule and on target for milestones.

PI Response to Reviewer Comments:

- CO₂ delivery is a crucial component of making algae biofuel a reality. Flue gas delivery for open-pond systems is particularly challenging with difficult permitting and engineering/cost issues. Our 8-acre open-pond operations have been integrated with CO₂ supplied from flue gas for 3 years, and our approach resolves the permitting and engineering/cost issues. We are excited to lead this project, which will provide a good option to the algae industry for low-cost CO₂ delivery by making further improvements to the efficiency of the CO₂ supply system.

ATMOSPHERIC CO₂ CAPTURE AND MEMBRANE DELIVERY

(WBS #: 1.3.2.330)

Project Description

Increasing the CO₂ concentration in gas supplied to a microalgae growth system can improve its productivity many fold over using atmospheric air. While flue gas seems like a good source of CO₂-enriched gas, it is not sustainable, can require significant transportation costs, and can include contaminants that can be toxic to the microalgae and contaminate fuel or other high-value products. We will overcome this obstacle by concentrating atmospheric CO₂ at the site of microalgae growth using moisture swing sorption (MSS) to provide a sustainable source of CO₂ without contaminants. MSS uses a dry/wet cycle to passively collect and concentrate ambient CO₂ about 100 fold. We propose to deliver the concentrated

Recipient:	Arizona State University
Principal Investigator:	Bruce Rittmann
Project Dates:	10/1/2015–2/28/2018
Project Category:	Ongoing
Project Type:	FY 2015—Targeted Algae Biofuels and Bioproducts (TABB): DE-FOA-0001162
Total DOE Funding:	\$1,000,000

CO₂ using special bubble-less gas-transfer membranes, called membrane carbonation (MC). MC delivers CO₂ via diffusion on demand with efficiencies near 100%, which is a significant improvement over sparging. We will combine MSS and MC to deliver CO₂ to microalgae growth systems with high efficiency and at a rate that is high enough to promote high biomass production rates in closed or open systems. The project’s objective is to scale up both approaches and integrate them into a single system that we will test at prototype scale outdoors using various algal strains (Scenedesmus, Chlorella, and Syn-

Weighted Project Score: 6.4

Weighting: For ongoing projects, there is equal weighting across all four evaluation criteria: Approach, Relevance, Accomplishments and Progress, and Future Work.

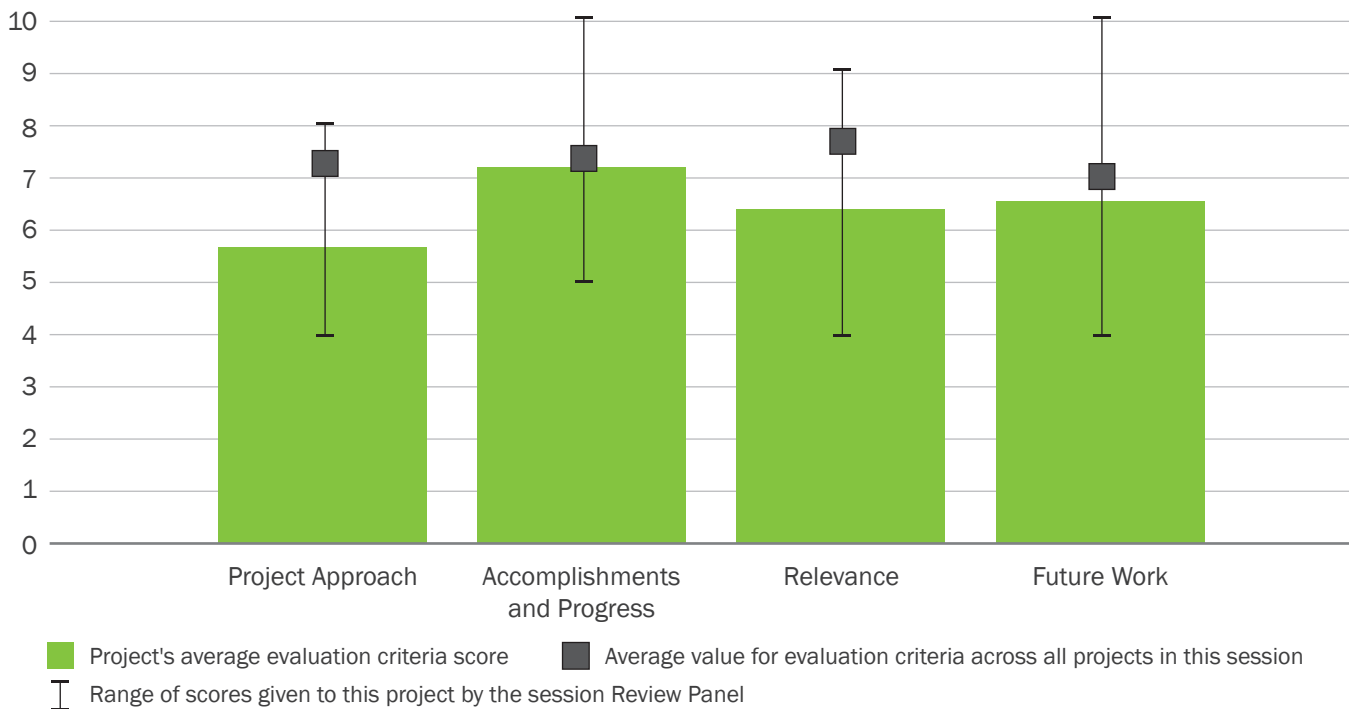

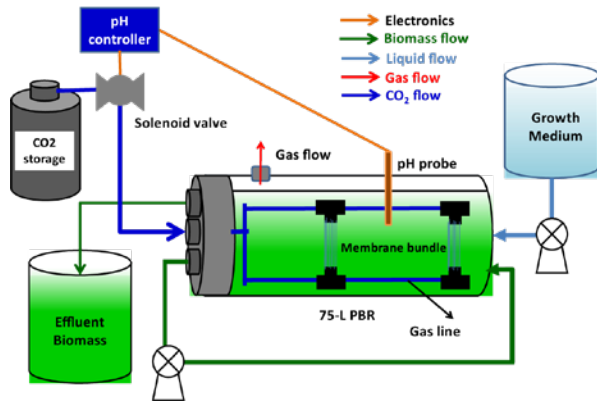

echocystis) that grow optimally with different concentrations of inorganic carbon.

Overall Impressions

- This project is attempting two innovative developments. One is for capturing atmospheric CO₂ using a “filter unit,” and the other is a new method for delivering CO₂ to PBRs using membranes. I would rather these were separate projects so the focus would be strengthened. The approach for releasing CO₂ from a carbonate mixture and delivering gaseous CO₂ to the media using membranes has several processing steps, equipment, and requires energy input. It is not clear to me the cost-benefit of this approach, as we could much more directly feed the carbonate solution to the media. The cost of the filter unit is prohibitive. I understand that the project is exploring cost-reduction ideas for the filter unit. If the team is not able to significantly reduce the cost of the filter unit, maybe they will be able to recommend where additional research is needed to potentially make this approach feasible in the future.
- This project addresses an important goal of atmospheric CO₂ capture for algal cultivation, which could be game-changing. Good progress has been made in demonstrating the underlying technologies and evaluating the economics. However, the complexity and energy requirements of the system would seem to make economic viability of this

approach extremely unlikely (as supported by the TEA). The value proposition for the CO₂ delivery system is particularly doubtful, and resources for that part of the project should be redirected to reducing costs in the CO₂ capture technology.

- Overall, this project illustrates an innovative approach that could provide significant impact. Some particle concerns with the potential scalability of a system of this nature may be difficult to overcome. But, this level of out-of-the box thinking drives innovation.
- Novel carbon capture and delivery system that is definitely applicable to PBRs, but needs significant work on cost reduction, open-pond suitability, and scalability.
- Improving delivery of CO₂ to algal ponds is important, and this project utilizes a novel technology—anionic resin sheets. The concept is interesting; however, there should be careful attention paid to system engineering and TEA to ensure this system/process is viable for industry.
- The proposed technology concentrates atmospheric CO₂ for delivery into algae production systems, which, if successful, would add considerable flexibility to land available for deployment of algae farms. The project appears to be on schedule and meeting proposed milestones. It is unclear if the proposed approach will be able to de-risk a technology that appears to have cost-prohibitive capital requirements.

PI Response to Reviewer Comments

- In principal, the carbonate/bicarbonate storage solution could be fed directly to the PBR in lieu of extracting and compressing the CO₂ gas for delivery via MC. However, this approach presents several problems: (1) photosynthesis normally drives up the

pH by consuming inorganic carbon and reducing nitrate, so delivering the acidic form avoids the need for adding acid to regulate the pH; (2) delivering bicarbonate requires a balancing cation, usually Na^+ , which increases the salt concentration; and (3) the storage tank contains a mixture of carbonate and bicarbonate at high pH such that it can more efficiently take up CO_2 delivered from the capture system, whereas PBRs are typically operated at a pH near 8.5. Thus, adding bicarbonate from storage will tend to increase the pH of the bioreactor, requir-

ing compensating forms of acidity. Put another way, extracting accumulating alkalinity from the algae pond would be expensive. The storage system, as designed, retains the alkalinity in the storage tank and only transfers CO_2 to the microalgae.

Another more direct approach might be to deliver captured CO_2 directly to the PBR using a fabric contactor and bypassing the storage subsystem. As part of the final report, the team will suggest future lines of research to address commercial feasibility.

ALGAE DISCOVER PROJECT: DEVELOPMENT OF INTEGRATED SCREENING, CULTIVAR OPTIMIZATION, AND VALIDATION RESEARCH

(WBS #: 1.3.2.501, 502, 503, 505)

Project Description

The Algae DISCOVER Project is a national laboratory consortium consisting of PNNL, LANL, NREL, and SNL. The overall objective of the Algae DISCOVER project is to develop an integrated platform for standardized, deep characterization of high-productivity microalgae strains for robust year-round outdoor cultivation. In this 3-year project cycle, we will characterize at least 30 selected strains in terms of their detailed growth characteristics (TIER I); evaluate 10 strains in terms of their seasonal areal biomass productivity, basic biomass composition, and resilience to biological stressors (TIER

Recipient:	Multi-lab
Principal Investigator:	Michael Huesemann
Project Dates:	10/1/2016–9/30/2019
Project Category:	New
Project Type:	AOP
DOE Funding FY 2014:	\$0
DOE Funding FY 2015:	\$0
DOE Funding FY 2016:	\$0
DOE Funding FY 2017:	\$1,500,000

II); improve and further characterize 6 strains in terms of more detailed biomass composition and biological stress resistance in indoor ponds (TIER III); and test 4 strains in outdoor ponds (TIER IV) to provide inputs to life-cycle and techno-economic analyses (TIER V). This streamlined, coordinated effort capitalizes on the consortium labs' complementary core capabilities in environmental simulation and productivity prediction, robustness evaluation, biomass valorization, and strain improvements. In summary, the DISCOVER project will develop a standardized, industrially relevant process for characterizing

Weighted Project Score: 8.0

Weighting: Approach–25%, Relevance–25%, and Future Work–50%.

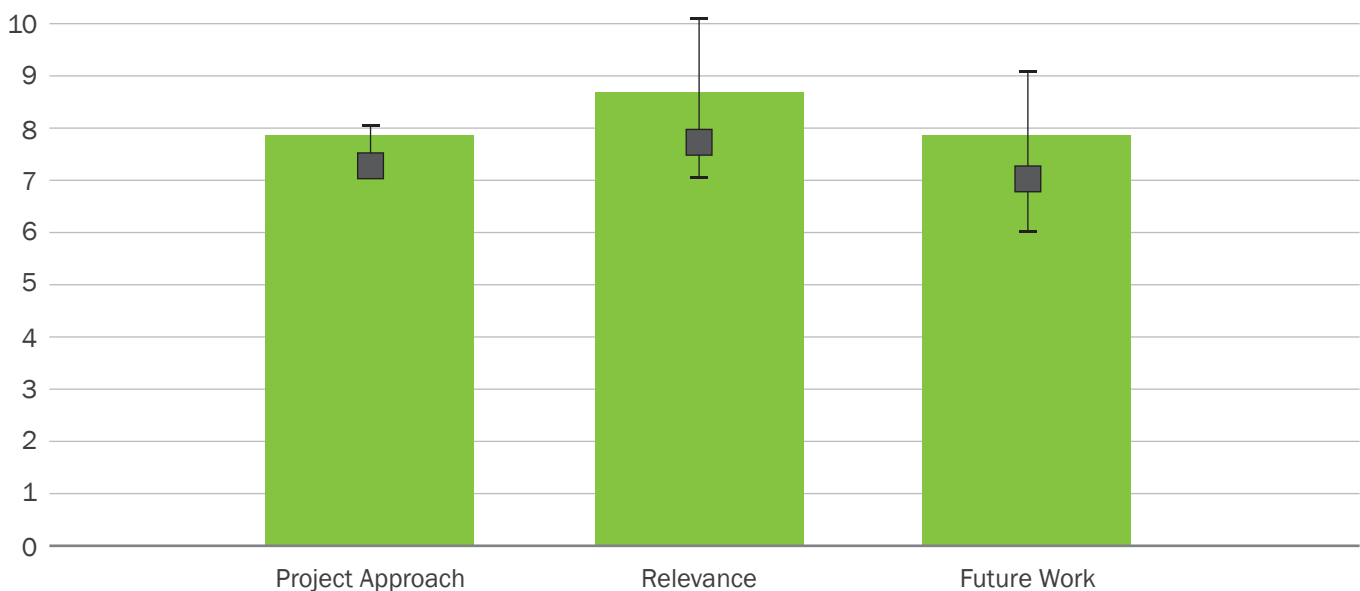

■ Project's average evaluation criteria score
 ■ Average value for evaluation criteria across all projects in this session
 Range of scores given to this project by the session Review Panel

potential biofuels/bioprocess strains and aims to deliver the best strains to industry to assist in meeting BETO's goal of producing biofuels at less than \$3/gge.

Overall Impressions

- This project appears to be very competently planned with good use of industry/academic expertise. The project goal of identifying specific strains and then going through a process of strain down-selection until finally testing in outdoor ponds and then developing a TEA should provide good characterization data and may also achieve a new SOT level. However, I suggest the project test how well their outdoor results in a small outdoor pond on a controlled site translates to larger ponds that are operated as would be expected for a large commercial facility.
- This relatively massive project seeks to identify and thoroughly characterize new strains with high potential for fuels and co-products. The overall approach is excellent and inclusive of many critical screens. It is also a model for inter-laboratory cooperation. There were some questions raised by industrial growers in the review session as to how well maximum specific growth rate of dilute cultures in microtiter plates will ultimately relate to productivity.
- The project's goal of setting the "gold standard" of strain evaluation is certainly within reach; however, the size limitation on final outdoor trials will eventually be a significant limitation.
- The development of a gold standard algal prospecting and strain development pipeline is highly meritorious, and the DISCOVER project is an organized, coordinated effort aimed at doing this. Strengths include leveraging national lab core capabilities and

integrating efforts across multiple institutions. There are some concerns with workflow organization.

Waiting until strains are completely characterized in the lab prior to conducting pond trials may be misguided because some strains that perform well outdoors may appear inferior to strains that perform well at the bench.

- This project represents an ambitious integration of national lab capabilities from strain screening, to optimization, to field validation. The project is clearly organized and managed. Early iterative indoor/outdoor testing is encouraged.

PI Response to Reviewer Comments

- Regarding screening at low cell densities: The DISCOVER screening process is based on our long-term experience in biomass growth modeling (validated for more than five strains) where we found that cells with a high maximum specific growth rate (measured in dilute cultures) and low light extinction coefficient have high biomass productivity in dense cultures.²¹ Thus, strain screening in dilute cultures is predictive of productivity in high-density cultures.

Regarding conducting outdoor trials at different scales: The testing of strains in ponds of different sizes is beyond the proposed scope of the DISCOVER project. However, depending on budget availability, it may be possible to test selected strains in ponds of different sizes at the ATP3 testbed site. ATP3 testbeds were developed to address algae production scaling challenges, and productivity comparisons have been performed across different scales in the past (for example, we are aware that the Cellana Kona Demonstration Facility, an ATP3 testbed site, ran comparative outdoor pond trials at 1,000 and 60,000 L). Furthermore, depending on industry interest in se-

²¹ M. Huesemann, B. Crowe, P. Waller, A. Chavis, S. Hobbs, S. Edmundson, M. Wigmosta, "A Validated Model To Predict Microalgae Growth in Outdoor Pond Cultures Subjected to Fluctuating Light Intensities and Water Temperatures," *Algal Research* 13 (2016): 195–206, <https://doi.org/10.1016/j.algal.2015.11.008>.

lected strains, these could be grown at larger outdoor facilities. We will consult with our Technical Advisory Board regarding their knowledge of the effects of scale and will take advantage of any interest in potential outdoor testing at industrial facilities.

Regarding testing strains outdoors at TIER IV and not earlier in the 'pipeline:' There are many reasons why we developed a tiered approach for strain testing, such as time- and cost-effectiveness (i.e., similar to drug screening), knowledge of a strain's temperature and salinity tolerance, and pre-confirmation of high biomass productivity potential in PNNL's laboratory environmental algae pond simulator PBRs. In addition, in evaluating robustness in terms of predator or pathogen resistance, indoor testing under simulated environments has numerous advantages over a program of outdoor testing. Pond crashes are somewhat stochastic and unpredictable, so a dependence on 'naturally occurring crashes' severely limits the amount and quality of data that can be recovered.

With indoor climate simulation ponds, we can control the conditions under which studies are conducted and are not hostage to the vagaries of weather, nor limited to specific growing seasons, single growth conditions, or naturally occurring environmental inputs to cause crashes. Furthermore, uncontrolled environmental inputs from outdoor culture can confound the measurement of resistance to specific predators or pathogens. In short, we can collect much more useful information on resistance through controlled challenge experiments. Finally, through the use of environmental simulation ponds, we do not run the risk of contaminating other portions of the outdoor test facility or compromising other experiments.

Lastly, there may be a misunderstanding regarding the outdoor testing schedule. Outdoor testing will start early in the project (not at 2.5 years): there will be two rounds of outdoor strain testing with the first round starting as early as the second quarter in Year 2 and the second round starting in Year 3.

GENETIC BLUEPRINT OF MICROALGAE CARBON PRODUCTIVITY

(WBS #: 1.3.2.504)

Project Description

The potential of microalgae to emerge as major biofuel producers is limited by the fact that maximal internal carbon accumulation (lipids and/or carbohydrates) in algae occurs at the expense of cell growth. Furthermore, different strains of algae have adapted and evolved in various environmental conditions and thus rotation of specific “seasonal” strains is required to maximize/stabilize biomass production throughout the year. The project objective is to gain a better understanding of algal biology, in particular (1) mechanisms regulating carbon production and switches from rapid growth to stress-induced carbon storage, and (2) growth responses at varied temperatures critical to overcome these limitations. Improving the

Recipient:	Lawrence Berkeley National Laboratory
Principal Investigator:	Igor Grigoriev
Project Dates:	10/1/2016–9/30/2019
Project Category:	New
Project Type:	AOP
DOE Funding FY 2014:	\$0
DOE Funding FY 2015:	\$0
DOE Funding FY 2016:	\$0
DOE Funding FY 2017:	\$125,000

productivity and robustness of algal strains against perturbations will require extensive advanced genetic, genomic, and molecular biology tools, which currently are lacking for most algal species. This project directly addresses barriers to genetic modification and development, as described in the BETO MYPP. Combining expertise in algal genomics, transcriptomics, metabolomics, and gene editing to characterize novel algal strains with the highest potential as third-generation biofuels will improve bio-

Weighted Project Score: 7.8

Weighting: Approach–25%, Relevance–25%, and Future Work–50%.

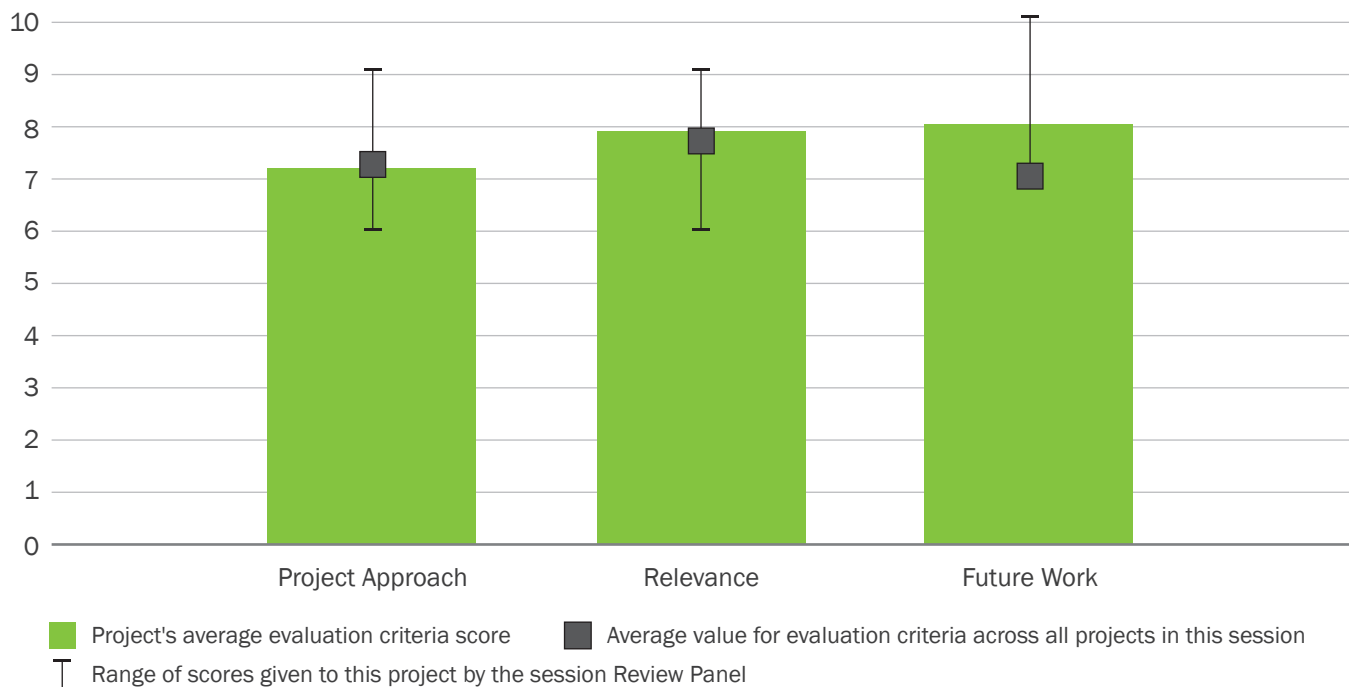



mass production rates by 25% and significantly decrease the lag time for genetic modification.

Overall Impressions

- Hopefully this project is successful in speeding up the time it takes to understand a strain. It would be good if the presenter provided more information on the extent of the issue they are attempting to address and the real benefits to industry if their intended target for reducing the schedule is realized.
- Development of functional genomics tools for new strains and new cultivation conditions is of potentially high value. A massive amount of data will be collected under this project, but at this point the nature of the expected deliverables is quite vague. Choice of temperature variations as the first conditions to study is questionable.
- Overall, this project is another genetic development plan to enhance overall large-scale productivity.

Issues with using small-scale optimization information and a slow throughput may be an issue. But the overall improvement of genetic information in the algal community, which is lacking in many respects, would lend greatly to the overall understanding of certain variables that can lend to the overall improvement of algal biomass production.

- Great tool for strain improvement work; integrating the omics and deciphering the regulatory network will help elucidate not only seasonal transition information, but can also help to maximize product/co-product production.
- This straightforward project aims to sequence the genome and do initial/exploratory functional genomics studies on an industrially relevant strain (*Chlorella luteoviridis*). Eventually, this project will enable strain engineering for enhanced production traits in this species. While it is difficult to say whether results from this project will directly contribute transformational knowledge for large-scale cultivation, it will certainly enable additional investigations on an organism with industrial potential, making this project a relevant and important part of the portfolio.
- The proposed work seeks to demonstrate a method for using a ‘pipeline approach’ for coupling genetic and genomic technologies to improve strain performance. It is unclear whether the project will result in an improved strain that has industry relevance, but demonstration of the pipeline approach should have wide applicability.

PI Response to Reviewer Comments

- Expected deliverables for this project include a (1) functional genomics pipeline applicable to various strains produced by other BETO projects, (2) accelerated cycle to identify gene targets for algal strain improvement, and (3) list of targets for the *Chlorella luteoviridis* improvement.

Regarding choice of temperatures, we selected the *Chlorella* strain as the first pilot because it outperformed other strains in the Mesa, Arizona, outdoor pond experiments, and we aim to simulate these conditions with perturbation experiments in an environmental PBR to identify a ranked list of gene targets for strain improvement.

Regarding comments on low throughput, small scale, and industrial relevance, we intend to accelerate the target selection process, completing the first phase within 2 years (50% improvement over current cycle time). In the first small-scale experiments, we will develop a robust and customizable pipeline that can be applied to other industrially relevant strains at different scales. In addition, we will collaborate with NREL and its partners to further develop and improve *Chlorella luteoviridis* as an industrially robust strain.

THE GREENHOUSE: A COMPREHENSIVE KNOWLEDGE BASE OF ALGAL FEEDSTOCKS

(WBS #: 1.3.2.600)

Project Description

The main goal of this project is to create a multi-functional, web-based repository and novel software to organize and integrate metadata with algal ‘-omics’ profiles to standardize and accelerate algal strain improvement. Improving productivity in the presence of abiotic and biotic stressors requires extensive ecological, genetic, and biochemical information, which currently is lacking for most algae. Successful completion of this project will help mitigate these barriers to achieve cost parity with petroleum-based fuels by 2022.

Specifically, this project will maintain and expand a web-based platform (www.greenhouse.lanl.gov) by developing and deploying (1) “user management” functionality to

Recipient:	Los Alamos National Laboratory
Principal Investigator:	Shawn Starkenburg
Project Dates:	10/1/2015–9/30/2018
Project Category:	Ongoing
Project Type:	AOP
DOE Funding FY 2014:	\$0
DOE Funding FY 2015:	\$0
DOE Funding FY 2016:	\$0
DOE Funding FY 2017:	\$350,000

enable both public and private data sharing for individual users or large consortia; (2) genomes of production strains; (3) strain-level diagnostics tools for crop monitoring and pathogen/predator detection; and (4) a pathway viewer and annotation tools that integrate and display genomics, metabolomics, transcriptomics, and proteomics data on biochemical pathway maps. These tools and resources enable academic and industrial entities to both contribute to and reap the benefits of BETO-funded national laboratory programs and serve as the foundation of

Weighted Project Score: 7.3

Weighting: For ongoing projects, there is equal weighting across all four evaluation criteria: Approach, Relevance, Accomplishments and Progress, and Future Work.

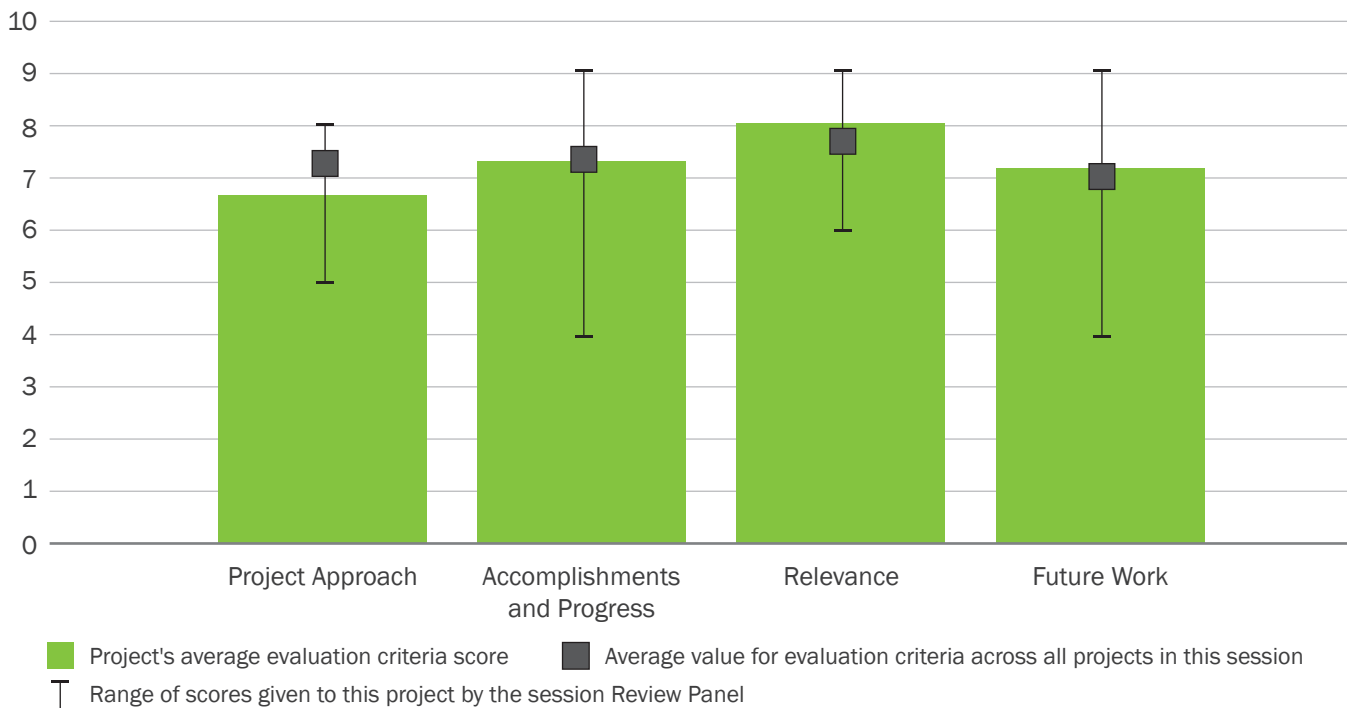

future BETO-funded, targeted strain-engineering efforts; transgene selection; molecular assisted breeding; genome editing; and identification of critical enzymes used to produce fuel precursor molecules and co-products.

Overall Impressions

- This website seems to be very useful and is currently being used by private industry. This website has the potential to include a wide array of metrics.
- The Greenhouse project is making excellent progress and is providing vital tools to the algal research community that are centralized and standardized. This project is on track to become one of the core foundational projects in the portfolio. Close ties to complementary projects and end users should be maintained.
- Overall, this is strong project with great collaboration and potential. The open-source system for accessing public data on specific species could lend greatly to the advancement of improving overall algal productivity. Issues with sourcing relevant material—not just lab-based material—could slow progress. It would be sound to source material that has been cultivated at the larger scale to strengthen the project.
- The Greenhouse tool has a lot of potential and very exciting plans for upcoming work; however, it needs to get into the hands of more people.
- In theory, a web portal that hosts genome data and -omics data and incorporates other knowledge of algal feedstocks is an incredibly valuable tool/resource. However, in reality, Greenhouse suffers

from a bit of an identity crisis in that it isn't clear if it's meant to be a data repository or an interactive analysis interface (or both). Current project progress has been made primarily on the data repository end, but its current iteration isn't functionally differentiated enough from other data repositories to offer a unique utility. This is a massive and commendable undertaking. Ultimately, the project may not have sufficient resources (personnel, expertise) to be successful in every aspect, but it has the potential to be very successful in certain elements, provided the focus is more finely honed.

- The project is in the process of developing a robust web-based portal to facilitate storage and dissemination of omics and metadata to accelerate strain improvement efforts. The team has made clear progress, and the web portal is currently functional. A clear set of improvements will be added to the portal, and the project appears to be on schedule.

PI Response to Reviewer Comments

- In its infancy, Greenhouse was strictly a data repository. Going forward, the focus will shift to building and deploying 'interactive' analysis tools customized for algal production strain characterization. Differentiation from other data repositories will improve as the aforementioned omics analytical tools are built in the later stages of the project. Furthermore, industrial relevance is a top priority. We will continue to seek consultation from industry to ensure the tools and omics resources disseminated through the Greenhouse website bolster strain improvement efforts.

MICROALGAE BIOFUELS PRODUCTION ON CO₂ FROM AIR

(WBS #: 1.3.2.900)

Project Description

The project objective is to demonstrate the potential feasibility of the AlgaeAirFix™ process. AlgaeAirFix™ uses the enzyme carbonic anhydrase (CA) to accelerate the mass transfer rate of CO₂ from the atmosphere into the algal culture, allowing microalgae biomass production without use of enriched CO₂ sources. The goal is to determine the enhancement of CO₂ mass transfer from air and resulting increases in algal productivity by adding commercially available CA. Experiments have been carried out with laboratory and climate simulation bench-scale reactors at PNNL, as well as outdoor ponds operated by the industrial partner, MicroBio Engineering.

The CO₂ mass transfer rate coefficient has been determined as a function of CA concentration, mixing speed,

Recipient:	Pacific Northwest National Laboratory
Principal Investigator:	Michael Huesemann
Project Dates:	10/1/2015–9/30/2017
Project Category:	Ongoing
Project Type:	FY 2013—Incubator: DE-FOA-0000974
Total DOE Funding:	\$900,000

temperature, salinity, and alkalinity. The baseline biomass productivity in outdoor ponds has been determined as a function of paddlewheel speed and alkalinity. A TEA and resource assessment has been carried out based on the data obtained to detail the cost-benefit potential of this technology and further R&D required to move the process to industrial reality. Favorable results would enable the production of algal biofuels without use of enriched CO₂ sources—such as power plant flue gases—thereby greatly increasing the potential of algae to contribute to reducing fossil energy use in the transportation sector.

Weighted Project Score: 7.4

Weighting: For ongoing projects, there is equal weighting across all four evaluation criteria: Approach, Relevance, Accomplishments and Progress, and Future Work.

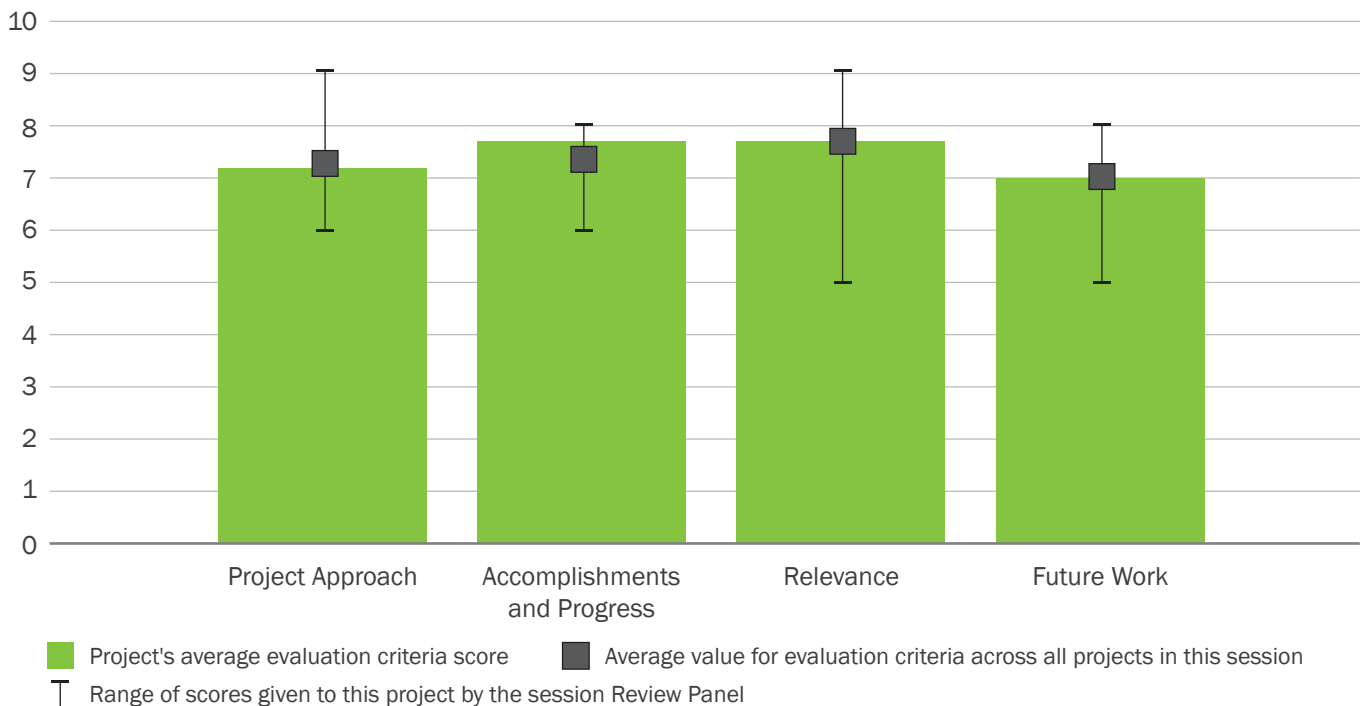

Overall Impressions

- This project has a good start on developing baseline values, identifying mechanisms, and exploring some approaches for increasing the CO₂ transfer rate to a pond media using a CA. Their future work includes some innovative ideas on increasing the efficacy of the CA and for altering the media properties to increase the CO₂ transfer rate.
- This work directly addresses the need to decouple production from CO₂ point sources, thus increasing the number of suitable sites and overall sustainability. Excellent demonstrations of the potential for enhancing atmospheric CO₂ mass transfer to the culture have been made. The current limitations of the project around the number of strains and water types are currently being addressed, and future work includes several promising avenues to reach the end goal.
- Overall, this project is an innovative approach that cost-effectively decouples large-scale algae farms from co-location issues.
- The most significant outcome of this project is the potential to uncouple algae production from CO₂ co-location. Much work is needed on how this would deploy at a relevant scale.
- Developing a cost-effective CO₂ delivery system to algae in order to boost productivity is a worthwhile endeavor. However, there are some major barriers to the success of AlgaeAirFix™, the most prominent one being the requirement for external addition of an expensive enzyme. The solution presented (endogenous CA production) is problematic, as there will necessarily be issues like unanticipated energetic costs reducing productivity. There are several other potential feasibility issues that should be investigated, such as enzyme stability in ponds due to both abiotic and biotic factors.
- Co-location with CO₂ sources could severely limit algal biofuel siting options, and viable technologies that enable use of atmospheric CO₂ could broaden deployment options dramatically. If the proposed technology is able to be deployed without reducing current or productivity targets, results from an initial TEA suggest that it could be economically viable. The project appears to be on schedule and has met a go/no-go decision on time.

PI Response to Reviewer Comments

- Regarding barriers to the success of AlgaeAirFix™: There are, certainly, major barriers to successfully growing microalgae on just air levels of CO₂. Extracellular CA will be a key factor in this process; however, at present, it is undefined exactly how extracellular, if, as in essentially all cases studied, it is only periplasmic or possibly excreted into the culture medium. Without going into a long discussion, these issues will remain for future study. The main objective of the present project is to demonstrate that there is a path to enhancing atmospheric CO₂ transfer into algal ponds sufficiently to allow for a relatively high productivity. Follow-up research will need to address translating this work into an actual working that is economic process. However, we emphasize that, at this point, the need is for a proof of concept from which the economic issues can be addressed via conducting a TEA. Also, there are several approaches to this process, from shallow cultures and attached biofilms to use of alkaliphilic algal strains operating at high pH (where chemical enhancement will also play a role). These will be addressed in our follow-on proposal.

DIRECT PHOTOSYNTHETIC PRODUCTION OF BIODIESEL BY GROWTH-DECOUPLED CYANOBACTERIA

(WBS #: 1.3.2.910)

Project Description

This project aims to engineer the photosynthetic production of ethyl laurate—an excreted, “drop-in” biodiesel alternative resistant to microbial scavengers—using cyanobacteria and inputs of just CO₂, water, and light. Also, we will induce growth arrest of the culture, decoupling ethyl laurate production from culture growth, to enhance ethyl laurate productivity. Ethyl laurate production will be further increased by (1) boosting metabolic flux through the fatty acid biosynthesis pathway to intermediates used for ethyl laurate production, and (2) reducing the production of exopolysaccharides.

Recipient:	Arizona State University
Principal Investigator:	Wim Vermaas
Project Dates:	9/30/2016–3/31/2018
Project Category:	New
Project Type:	FY 2014—Incubator II: DE-FOA-0001320
Total DOE Funding:	\$1,818,000

The project builds on the team’s prior success in efficient photosynthetic production of laurate by an engineered strain of the cyanobacterium *Synechocystis* sp. PCC 6803; this strain contains a thioesterase that cleaves off laurate from the native fatty acid biosynthesis machinery. This platform strain will be engineered further to improve laurate production, convert laurate to lauryl-CoA, co-produce ethanol (using constructs provided by Algenol), and synthesize ethyl laurate from lauryl-CoA and ethanol. Inducible gene circuits are being engineered to dynamically arrest cell growth without harming viability and metabolic activity. Additional genetic changes to reduce the level

Weighted Project Score: 7.6

Weighting: Approach–25%, Relevance–25%, and Future Work–50%.

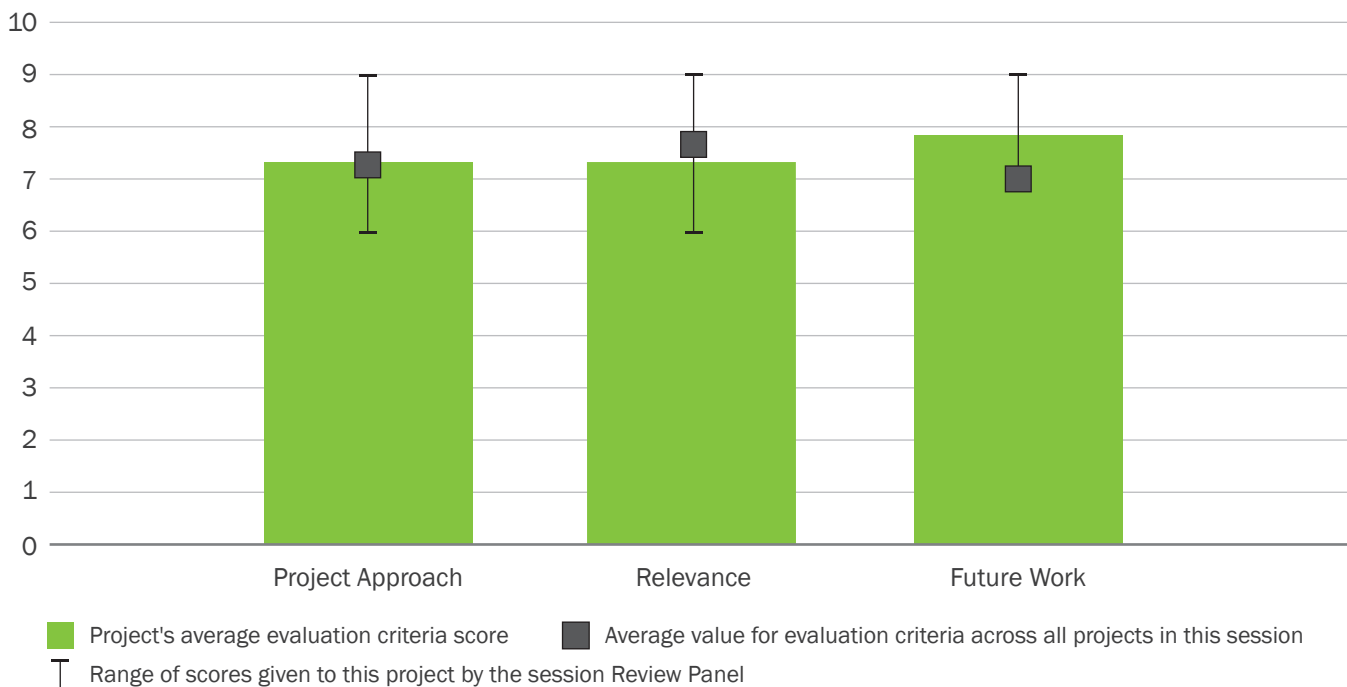

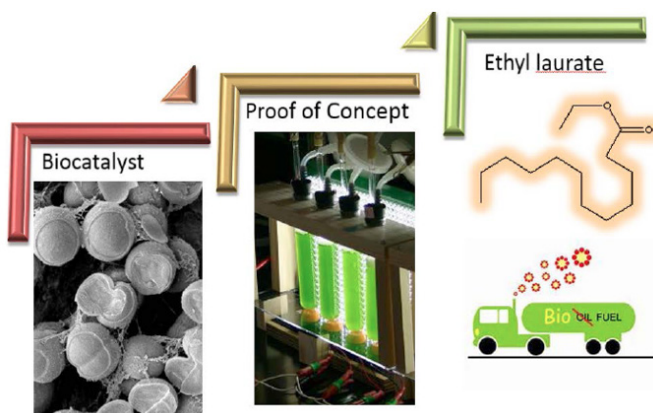

of exopolysaccharides will help to further direct fixed carbon toward biofuel production while also reducing the level of potential substrate available to opportunistic heterotrophic contaminants.

Overall Impressions

- Great start on getting the bacteria to produce both laurate and ethanol. This project has identified the need to modify the cyanobacteria to form the ethyl laurate and for increasing the carbon flux to product. I believe the TEA they generate will be fairly uncertain until they can develop a solid plan for harvesting methods and cleaning methods; I believe both of these hurdles will be difficult to overcome.
- This is an exciting, potentially transformational approach to direct fuel production by cyanobacteria. This is high-risk research with many challenges, including some that are not considered, but the potential payoffs of obviating harvest, extraction, and downstream processing are huge. This adds valuable diversity to BETO's portfolio. Near-term production of the product as an industrial chemical could help with deployment. Future work is quite ambitious and could benefit from early TEA to help narrow focus.
- This project has an innovative concept that could produce significant results moving forward.

- Novel concept for meeting fuel production goals. Because the project is so new, commercial scalability is unclear; TEA work will need to address this.
- Production of ethyl laurate in cyanobacteria has the potential to be transformative, provided there is a clear path to scaling up the technology. Early results are exciting and promising, and the investigators clearly possess the technical expertise needed to explore the production of this compound in this organism and move it in the right direction. This project could be improved by assessing the potential of this product by contextualizing the work with engineering and economic analyses.
- The proposed plan of work for this high-risk, high-reward research seems appropriate for the FOA. The project identified a clear plan of work guided by appropriate management tools. Potential challenges were identified and incorporated into the project plan. If successful, the project will contribute to yield and cost goals of BETO's MYPP.

PI Response to Reviewer Comments

- One reviewer viewed the project to be potentially transformational, but also high risk with many challenges. We concur with this assessment and note that this project is a first step to prove feasibility of the approach. Details of harvesting, extraction, and downstream processing are not yet worked out extensively, as production rates and product accumulation on top of cultures first will need to be known and analyzed better. At that time, TEA for the whole process will be more useful. TEA will inform commercial scalability and potential.

We share reviewers' concerns regarding scalability, but we are still too early in the project to have a reasonable idea about the challenges that we will actually face. We anticipate that we will have further information on this at the next review. We have

engineering and TEA expertise on the team, and we can further expand the team in a next phase of the project after the current project comes to an end.

One reviewer shared the excitement and high-risk nature of the project with the first reviewer. Indeed, it is a high-risk project, but excellent progress has been made thus far. Another reviewer lauded the strong

start of the project, but views definition of harvesting and cleaning methods to be critical in developing an optimal and detailed TEA. We fully concur, and while development of harvesting and cleaning methods is beyond the scope of the current project, these are very important research directions once we have gathered information on the production rate and accumulation (on top of the culture) of ethyl laurate.

A NOVEL PLATFORM FOR ALGAL BIOMASS PRODUCTION USING CELLULOSIC MIXTROPHY

(WBS #: 1.3.2.920)

Project Description

Abundant, flat land in the southwestern United States plays little role in the current BETO algal portfolio, yet the region offers significant potential for algal biomass production if evaporative water loss issues can be addressed. The goal of this project is to utilize mixotrophic metabolism of cellulosic glucose and xylose by red algal extremophiles in the genus *Galdieria* to maximize biomass productivity. Mixotrophy couples stoichiometric oxygen-dependent sugar oxidation to photosynthetic CO₂ capture, thus reducing CO₂ supply costs and bioreactor mixing energy—two major contributors to greenhouse gas emissions in current algal biofuel models. Preliminary results show the low pH and high temperatures preferred by *Galdieria* allow it to outcompete other microorganisms

Recipient:	Arizona State University
Principal Investigator:	Peter Lammers
Project Dates:	9/1/2016–8/31/2018
Project Category:	New
Project Type:	FY 2014—Incubator II: DE-FOA-0001320
Total DOE Funding:	\$1,956,515

for sugar utilization, achieving volumetric productivities between 0.5 and 1.0 g/L/day outdoors. Our biomass productivity target is to exceed 50 g/m²/day, which is a minimum fivefold increase over baseline photoautotrophic cultivation. The project includes techno-economic and greenhouse gas emission modeling for both vertical and tubular PBRs for overall decision support and down-selection of the best reactor for deployment in the southwestern United States. Resource assessments will identify cellulose sources available in the deserts of this region. The project also will identify direct and indirect practices that limit catabolic repression of photosynthesis by cellulosic sugars.

Weighted Project Score: 6.8

Weighting: Approach—25%, Relevance—25%, and Future Work—50%.

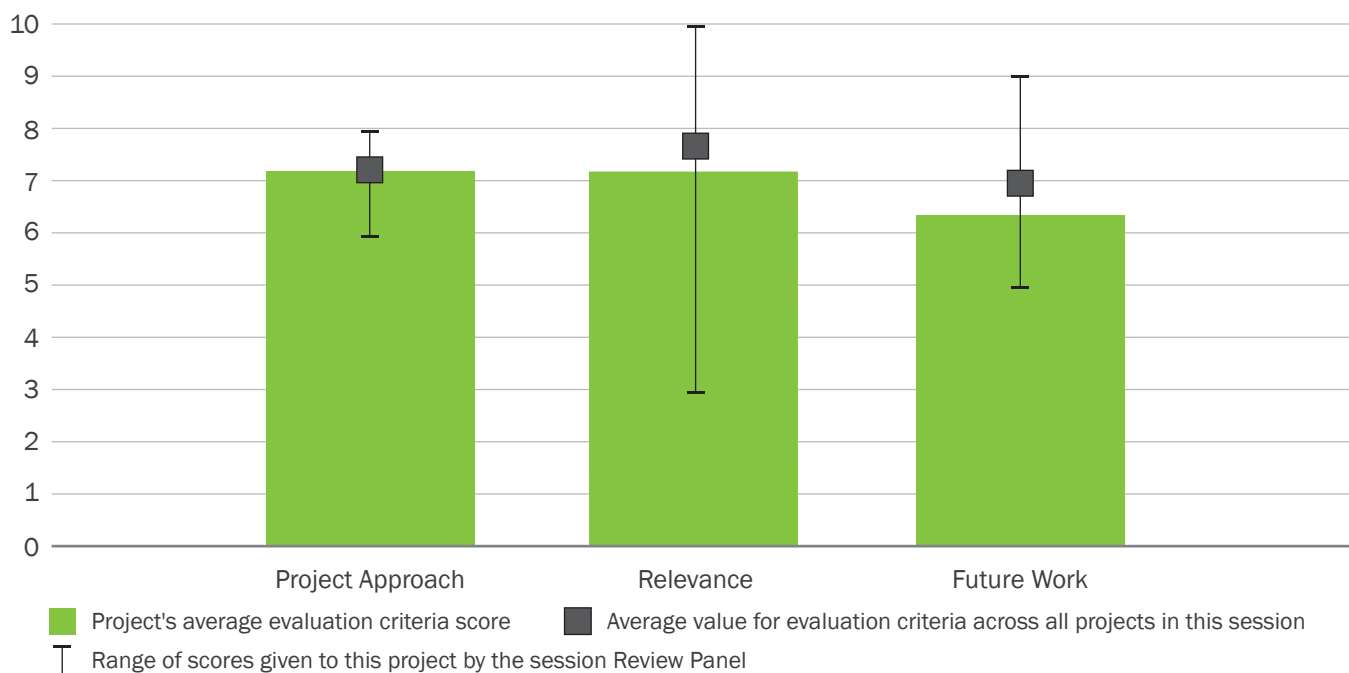

Overall Impressions

- This project appears to be mostly about advancing the state of making phycocyanin. Addressing the MYPP goals of high productivity with this method seems of minimal value, as the industry has already shown high productivities with certain cellulosic sugars. I expect this project to encounter issues with running a system with multiple strains that need to be kept in performance balance, keeping the system clean of competitors, and developing systems that can be effectively cleaned in place.
- This is an intriguing mixotrophy concept with potential to reduce gas delivery and mixing costs. Significant challenges include temperature dependence, cellulose resource availability, and PBR costs. Overall, this is a high-risk but potentially breakthrough approach that adds diversity to the portfolio. Given high production costs in PBR systems, addressing the purification and marketing of phycocyanin will be critical to successful commercialization, and this was poorly addressed in the presentation. The path of future work was not clearly articulated.
- Overall, this project seems like an innovative way to produce a high-value product and possibly consider the biofuel as a co-product in a sense. The production of this material in a PBR could become cost prohibitive, but the potential of high-value products may be beneficial in reducing the capital impact of the PBR system.
- Complex biology (Galdieria and Cyanidioschyzon merolae synergistic relationship) was put to use to “unlock algal productivity potential.” Additionally, stability of the system should be increased because crop protection issues are due to an acidophile environment and high temperatures.
- The advantages and disadvantages of mixotrophic cultivation of algal biomass have not been fully tested or explored, making this project an interest-

ing addition to the BETO portfolio. Though it is just getting started, and has demonstrated progress toward meeting the overall objective of maximizing algal productivity (to more than 50 g/m²/day). The short time frame during which this project will receive funding means that it will need to be highly focused in order to be productive. The path moving forward should be described more clearly.

- The team presented a clear history and rationale for the project. The technical and management approaches were identified and appropriate for the project. The team is encouraged to make an effort to measure the relative contribution of fixed carbon that comes from heterotrophic versus autotrophic growth. Without these measurements, it is unclear how mixotrophic efforts (and results reported for areal productivity) are aligned with BETO MYPP goals.

PI Response to Reviewer Comments

- This project is based on a novel cultivation route to fuel feedstock plus co-product designed to achieve a 5–10-fold increase in biomass productivity. Previous BETO-funded work by members of this team has established HTL-based conversion to biocrude at yields up to 40% from Galdieria feedstock. The TEA, LCA, and resource assessment tasks will evaluate fuel-scale manifestations of the cellulosic mixotrophy approach in the arid southwestern United States with phycocyanin co-product analysis built into the TEA. Phycocyanin yield maximization is directly addressed in the proposal, including glucose/xylose limitation prior to harvest and other strategies. Heliae will focus on nutraceutical-grade phycocyanin in the \$100–\$200/kilogram price range. A 10% market share could be achieved with a 25-acre mixotrophic facility.

A detailed TEA is included (Task 8) to guide the proposed work. We specifically target the arid

southwestern United States region for deployment with a major design objective to minimize evaporative water loss. Thus, PBR use is a strategic necessity. Various PBR design concepts (Task 5) will be evaluated to minimize the cost of the system. Plans to extend the mixotrophic growing season through winter will evaluate cultivation at pH values of 0.2–1.0 to suppress contaminants.

The 24-month period of performance is divided into two 1-year phases. The first year focuses on establishing the degree of mixotrophy when growing on cellulosic hydrolysate, completing an initial round of PBR design and cost reduction and building the TEA and LCA tools. The second year combines cultivation and analysis to co-optimize the cultivation conditions and PBR design. In this phase, seasonal productivity data will be collected and leveraged by TEA and LCA to document achievement of final targets at the end of the project based on cost, emissions, and scale-up potential.

The team is well aware of the importance of maximizing photosynthesis in the context of a mixotrophic production platform. The relative contributions of photoautotrophy and heterotrophy will be addressed in Task 1 by quantifying metabolic gases in an off-gas, mass spectrometry analyzer. These values will be used as criteria to screen and down-select from six different *Galdieria* strain candidates. Metabolite analysis of Calvin-Benson cycle intermediates (Task 4) will help reveal underlying mech-

anisms. A potential route to maximizing photosynthesis is to restrict the rate of aeration in PBRs. The consequences of variable aeration rates with respect to cultivation and the balance of photo-/heterotrophic metabolism will be evaluated in the context of minimizing mixing energy for the LCA modeling (Task 9). The project presentation included elements of a dual culture approach to mitigate the risk of partial catabolic repression of photosynthesis by sugars. While this is a common sense approach, it is outside the approved scope of work and will not be pursued with the current funding. The PI apologizes for this confusion.

Our team is not aware of any stable, high-productivity mixotrophic system using cellulosic sugars other than our own. The team fully understands that mixotrophic systems must exceed the productivity and/or economics of any fermenter-based fuel-feedstock production system in order to be adopted. Project funding is based on the assumption of phycocyanin co-production along with fuel feedstock generation. The approved scope of work is for cultivation of a single strain that does not require any clean-in-place procedures (other than those used to clean the PBRs) to maintain culture stability based on the extreme pH and temperature conditions used. The full pH range of 0.2–4.0 will be used to extend the mixotrophy growth season along with rotation of *Galdieria* strains with high- and low-temperature optima for full-year production potential.

ALGAL FEEDSTOCKS LOGISTICS AND HANDLING

(WBS #: 1.3.3.100)

Project Description

This project addresses feedstock logistics challenges occurring between algal biomass production and conversion in order to provide solutions that assist in meeting conversion cost targets. The goal of this project is twofold: to manage seasonal variation in algal biomass production through stabilization, and to reduce ash to increase conversion yield. Algal biomass is susceptible to rapid degradation once harvested; losses have been measured at 2%–3% per day. This project will demonstrate a wet storage approach that preserves harvested algal biomass for 6 months and enables a biorefinery to run year-round with a consistent feedstock supply.

Wet, anaerobic storage, or ensiling, is a low-cost storage approach that is commonly used to preserve wet herba-

Recipient:	Idaho National Laboratory
Principal Investigator:	Lynn Wendt
Project Dates:	10/1/2016–9/30/2019
Project Category:	Ongoing
Project Type:	AOP
DOE Funding FY 2014:	\$350,000
DOE Funding FY 2015:	\$0
DOE Funding FY 2016:	\$0
DOE Funding FY 2017:	\$800,000

ceous feedstock. Initial storage studies with algae/herbaceous blends have demonstrated losses of less than 10% over 1 month and 10%–17% over 6 months, meeting a go/no-go milestone target of 30% loss. Wet storage of algae alone is also promising; preliminary results show 1-month storage losses as low as 6.5%. This project will also identify a process that stabilizes algal turf scrubber biomass and reduces its ash by more than 70%, which could be applied to other high-ash algae species. In these tasks, optimal conditions will be determined in the laboratory, followed by estimation of conversion performance

Weighted Project Score: 8.0

Weighting: For ongoing projects, there is equal weighting across all four evaluation criteria: Approach, Relevance, Accomplishments and Progress, and Future Work.

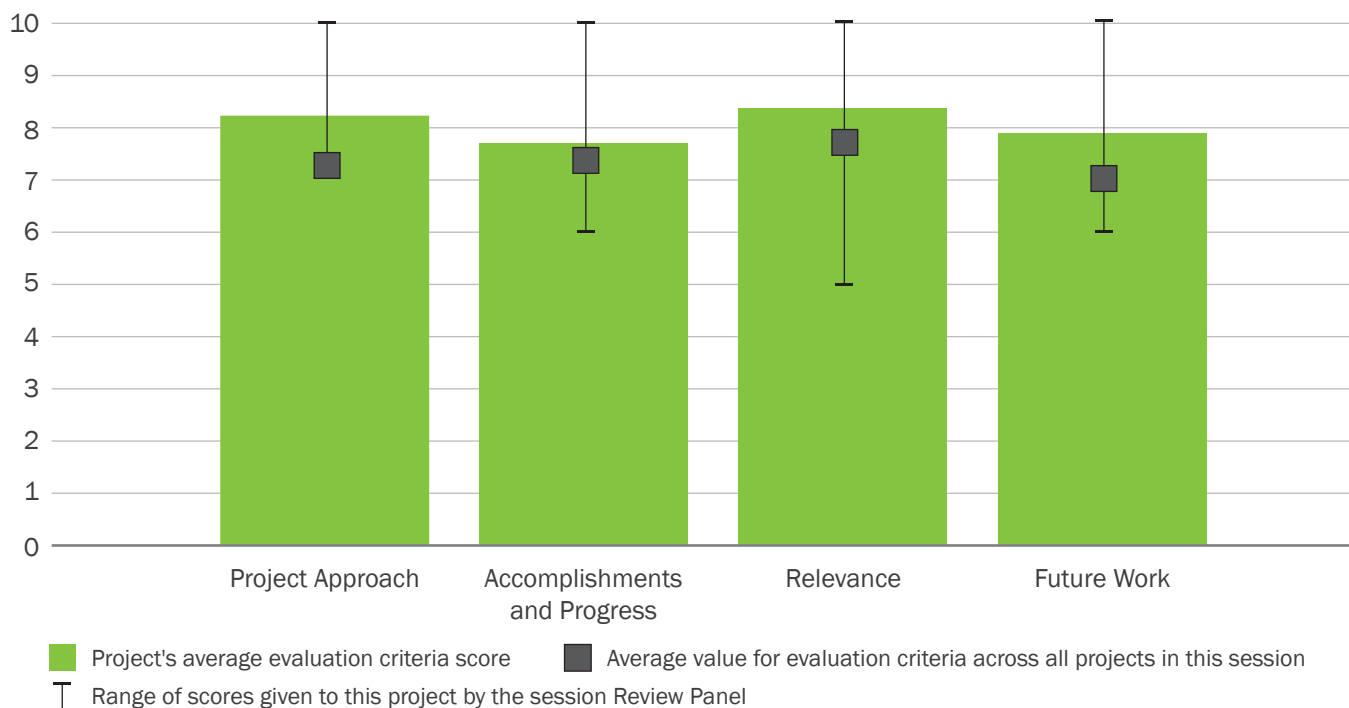



made in collaboration with national laboratory partners, and TEA will be used to compare to baseline targets.

Overall Impressions

- This project is very relevant for long-term storage, quantifying feedstock changes, and being able to feed at constant rate during low-productivity months. The project objectives are going to be relevant to the algae industry and potentially to other industries with high moisture content feedstocks and intermediates. A TEA that includes the cost of delivering blending material to the plant, the loss of dry matter, and conversion versus blending would be very helpful.
- This project is addressing key algal feedstock logistics barriers in novel ways. Adaptation of existing agricultural methods is a plus. Use of turf scrubber biomass might seem to be an unnecessary diversion from the industry mainstream.
- This project has interesting and innovative ideas. The blending of algal with other types of feedstocks

presents an interesting case for the supplementation of material for the larger-scale refining process. Ideas for the stabilization of harvested material to reduce the loss of target products could lend to production systems maintaining greater recoverable yields and in turn make the system more profitable. High ash quantities are a serious problem facing the industry, so steps to reduce the ash quantities provide a serious benefit to the industry as a whole.

- Storage and shipping is too often overlooked; this project provides a novel solution that appears to be more sustainable than traditional drying or refrigerated storage.
- Developing a baseline understanding of the effectiveness of algal biomass stabilization techniques and optimizing these techniques are essential elements of developing algae as an energy crop. With that in mind, this project represents a valuable step toward industrialization of microalgal biomass. Commendably, this project considers both technical and economic barriers of algal biomass stabilization, but could benefit from a more organized experimental approach to generate more concrete data that would improve the impact of the contribution.
- This project has a strong management plan with clearly defined goals and a rigorous technical approach. The scope addresses a clear bottleneck for large-scale production and may have near-term relevance for industry as well. The project does a good job building off of approaches in other agricultural disciplines, and early results have achieved project goals to minimize biomass losses during storage. Progress appears to be on track to meet project goals and milestones.

PI Response to Reviewer Comments

- We thank the reviewers for their thoughtful comments and suggestions. We agree that addressing feedstock logistics barriers and proposing solutions

for stabilization and maximizing conversion yield will advance the commercialization of algal-based biofuels. We agree that TEA and LCA should be conducted alongside experimental work such that the full impact of our stabilization approaches can be assessed. We have defined the unit operations and capital and operating costs of a system for stabilization of microalgae through blending and long-term storage and have found it as a cost-competitive approach to drying algae in order to manage seasonal production variation. We will continue to incorporate TEAs, in collaboration with NREL, for the storage of algae alone, and in conjunction with SNL on the impact of ash removal from biomass derived from a turf scrubber.

We have, and will continue to, incorporate multiple microalgae strains in our experimental plans to ensure that our approaches are applicable to a wide range of industrially relevant strains. We are also working with our partnering national laboratories to understand the impact that wet storage designs have on conversion potential.

While biomass derived for an algal turf scrubber was described by one reviewer as less relevant to mainstream processes, it does represent a feedstock that could benefit from advanced logistics (e.g., stabilization, ash mitigation). The ash-reduction approaches determined through this research effort may also be applicable to microalgae grown specifically for fuel production, where open-pond configurations could introduce significant ash contamination.

THERMOCHEMICAL INTERFACE

(WBS #: 1.3.4.101)

Project Description

This project is focused primarily on developing advanced HTL-processing methods to improve process efficiency and reduce capital and operating costs for the production of drop-in biofuels from microalgae. The algal HTL pathway is also developing processes to enable nutrient recycle/bioavailability from HTL waste streams and upgrading technology for the production of finished fuels. The project is validating process scale-up at engineering scale using a newly acquired HTL-processing system at PNNL with three skids for (1) feedstocks preparation, (2) HTL processing, and (3) product separations. All data from these efforts will directly support the pathway model TEA/LCA and SOT. Scale-up and technology transfer are important components of the project.

Recipient:	Pacific Northwest National Laboratory
Principal Investigator:	Daniel Anderson
Project Dates:	10/1/2016–9/30/2019
Project Category:	Ongoing
Project Type:	AOP
DOE Funding FY 2014:	\$1,000,000
DOE Funding FY 2015:	\$1,100,000
DOE Funding FY 2016:	\$1,520,000
DOE Funding FY 2017:	\$1,200,000

Overall Impressions

- This project is making progress on characterizing algal biomass, making some optimization improvements on the HTL process, and exploring methods for increasing nutrient recycle. I think the TEA of this project would benefit greatly by including a reputable member of industry practiced in upgrading oils to make them suitable as a refinery feedstock.

Weighted Project Score: 8.2

Weighting: For ongoing projects, there is equal weighting across all four evaluation criteria: Approach, Relevance, Accomplishments and Progress, and Future Work.

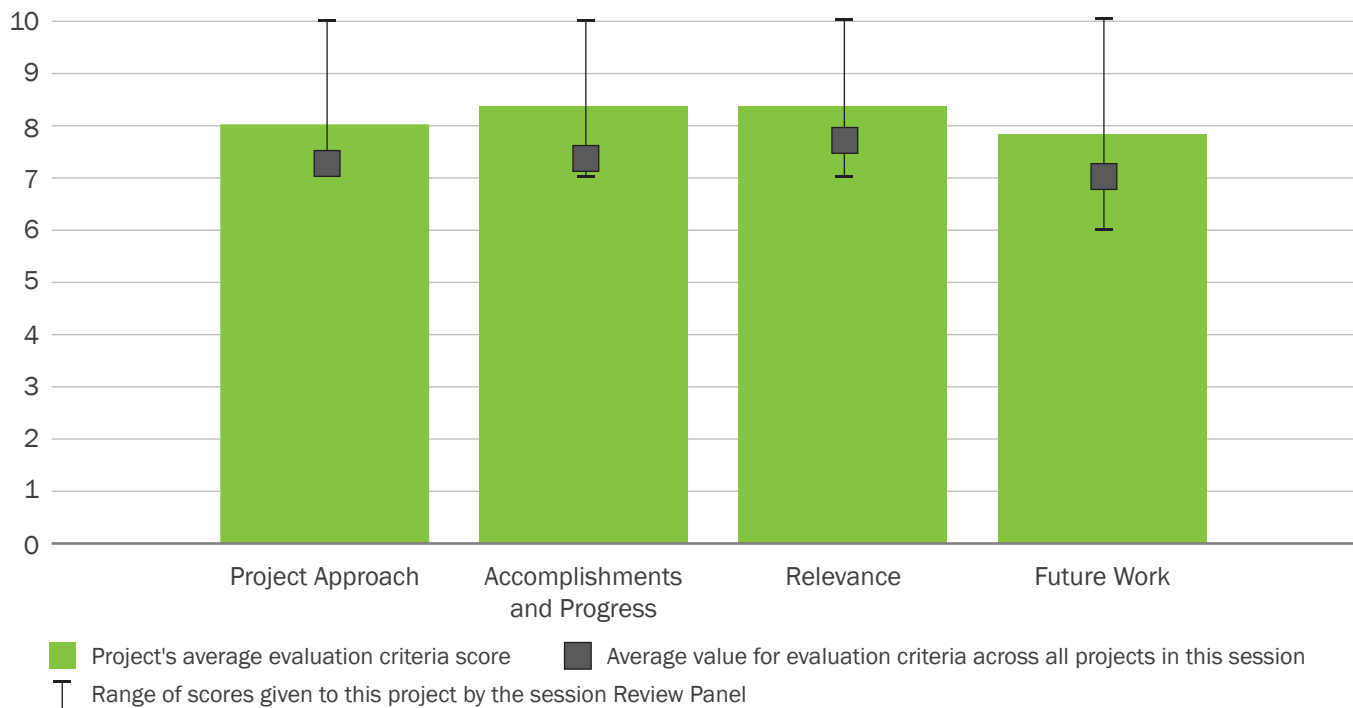



The industry partner should advise on the cost of upgrading (including the removal of metals) the different oils generated by different HTL operating conditions to make them acceptable to a refiner and at what discount the refiner would want in order to take the oils.

- This project is clearly on BETO's critical path. Impressive technology demonstrations and improvements have been made to date, with significant cost-reduction implications. The vision for the blending work is unclear. Further opportunities for aqueous stream valorization and interactions with end users of fuel products should be sought.
- Overall, the HTL platform has shown great progress since its inception. The development of the system has provided a substantial amount of data, as well as opportunities for cultivators and industry partners.

- This project demonstrates significant advancement of HTL development, particularly with the pilot unit to enable further field testing at multiple sites (unit is relocatable). Phosphate recovery from the HTL solids is an important step forward.
- The team continues to lead the field in quantifying the SOT for a promising conversion technology (HTL). The work is clearly aligned with BETO MYPP goals for low-cost conversion of algal biomass into biofuels. The team continually engages with leading algae producers (whether in industry, academia, or national laboratories) and has validated a number of process improvements that help increase efficiencies and drive down capital costs.

PI Response to Reviewer Comments

- Thank you for your review and insights.

The vision for future feedstock blending with algae will be based on (1) an ongoing resource assessment in a related project of the available feedstocks for potential blending with algae, and (2) the experimental results from testing selected blendstocks in the HTL process.

We believe you have an excellent suggestion in getting industrial participation, and this is the basis for future planned work through a new NREL-PNNL experimental project aimed at understanding the requirements needed for petroleum refinery acceptance. Key to this effort will be assistance from refining experts.

BIOCONVERSION OF ALGAL CARBOHYDRATES AND PROTEINS TO FUELS

(WBS #: 1.3.4.200)

Project Description

Algae biomass is an intrinsically heterogeneous feedstock consisting predominantly of proteins and carbohydrates under high growth conditions. Therefore, the objective of this project is to develop algae conversion technologies that enable utilization of multiple substrates for generation of algal-derived fuel products. Our approach was to engineer fermentation microbes and apply process optimization and intensification in order to biologically produce more than 10 g/L of fusel alcohols at productivity and yield of more than 0.5 g/L/hour and 0.2 g/g (equivalent to greater than 70% net theoretical yield), respectively, from whole benthic and microalgae hydrolysates. This objective supports BETO's 2022 MYPP goals

Recipient:	Sandia National Laboratories
Principal Investigator:	Ryan W. Davis
Project Dates:	10/1/2016–9/30/2019
Project Category:	Ongoing
Project Type:	AOP
DOE Funding FY 2014:	\$150,000
DOE Funding FY 2015:	\$300,000
DOE Funding FY 2016:	\$350,000
DOE Funding FY 2017:	\$350,000

to demonstrate algae biofuel yield of 5,000 gallons of bio-fuel intermediate per acre per year at \$3/gge.

Overall Impressions

- This project has potential for a combination of water cleanup and as a potential pathway for fuels/chemicals production. I think this is a useful first step for the next scale-up stage and the generation of a third-party-verified TEA.

Weighted Project Score: 6.4

Weighting: For ongoing projects, there is equal weighting across all four evaluation criteria: Approach, Relevance, Accomplishments and Progress, and Future Work.

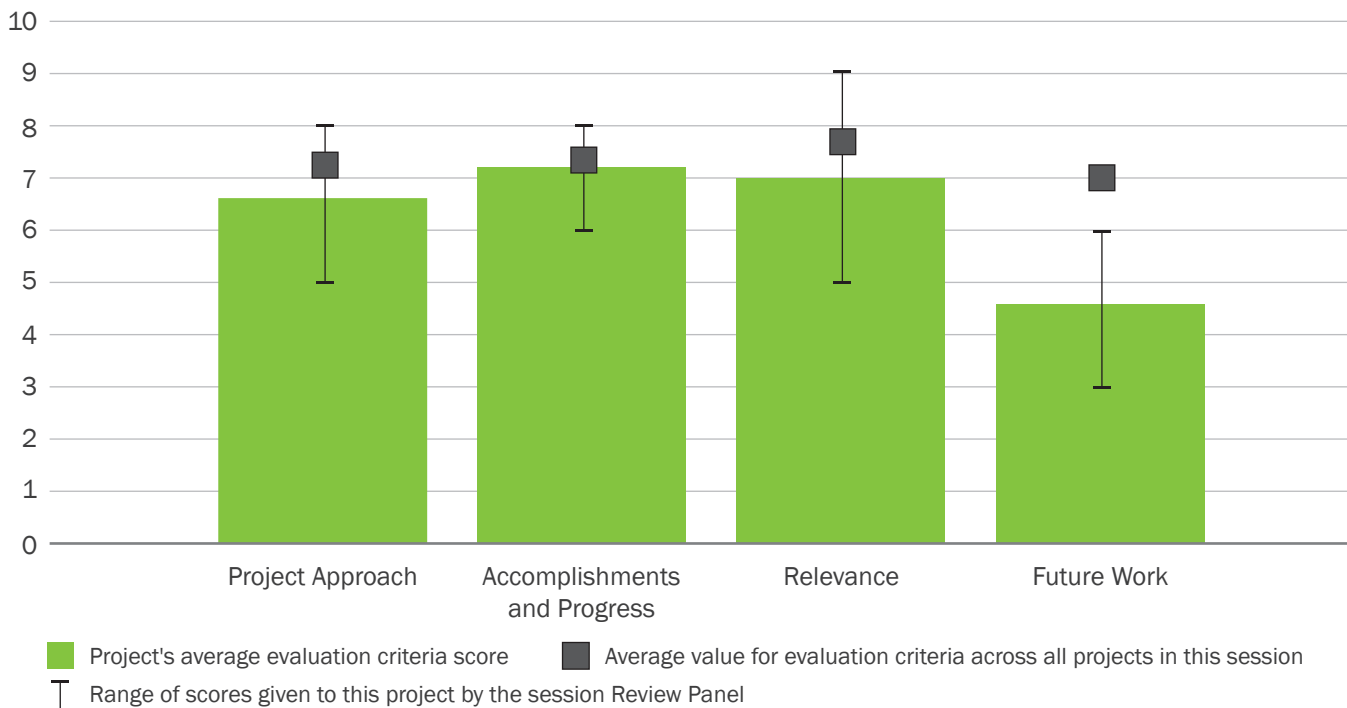



- This project explores an interesting alternative pathway for the utilization of algal proteins and carbohydrates. Excellent progress was made in the optimization of fermentation for fusel alcohol production. Relevance should be considered in the context of fusel alcohol as a higher-value co-product rather than a fuel. In order to decide whether future development of this approach is warranted, TEA needs to be addressed.

- Overall, this project has merit and the potential to meet the program’s goals and deliverables moving forward. Innovative approach using algal turf systems for production of new biomass. Productivity of benthic algal material may be an issue moving forward, as well as high ash content.
- This project demonstrates an excellent use of turf scrubber biomass from water cleanup to also generate fuels.
- This team’s efforts to increase biofuel yields and co-products through algal hydrolysate fermentation are clearly aligned with BETO MYPP goals to increase per-acre algal biofuel yields. There appears to be nice market flexibility in the target fusel alcohol products, from industrial solvents to biodiesel. It is unclear if the approach will have market relevance given several inherent disadvantages in the fermentation feedstock relative to competing technologies in the marketplace. High-density fermentation could be difficult with hydrolysates without expensive pre-concentration steps.

PI Response to Reviewer Comments

- The PI would like to thank the reviewers for their valuable insights.

ALGAL BIOMASS CONVERSION

(WBS #: 1.3.4.201)

Project Description

The Algal Biomass Conversion (ABC) project identifies and develops bolt-on unit operations for the Combined Algal Processing (CAP) scheme to valorize all algal components to fuels and chemicals to accelerate biofuel commercialization. ABC leverages work begun by the Sustainable Algal Biofuels Consortium, becoming an AOP project in FY 2015. CAP is the SOT for the algal lipid upgrading pathway. TEA models indicate that the cost of algal biomass production will never become low enough to support a process designed to produce only biofuels, and thus the addition of a scalable portfolio of co-products is the only way to achieve the target of less than \$3/gge. ABC's challenges include identifying production algal strains (especially halotolerant) with high carb/lipid composition, identifying co-products with

Recipient:	National Renewable Energy Laboratory
Principal Investigator:	Philip Pienkos
Project Dates:	10/1/2015–9/30/2018
Project Category:	Ongoing
Project Type:	AOP
DOE Funding FY 2014:	\$0
DOE Funding FY 2015:	\$500,000
DOE Funding FY 2016:	\$600,000
DOE Funding FY 2017:	\$500,000

sufficient price and volume to justify consideration, and developing co-product processes that can plug and play with CAP. We have identified a number of halotolerant strains with high lipid/carb content; demonstrated the fully integrated CAP process at bench scale, including the upgrading of the lipids to hydrocarbons; substituted succinic acid for ethanol with significant reduction in MFSP; demonstrated the conversion of algal sterols to surfactants; and demonstrated the conversion of algal proteins to four

Weighted Project Score: 7.4

Weighting: For ongoing projects, there is equal weighting across all four evaluation criteria: Approach, Relevance, Accomplishments and Progress, and Future Work.

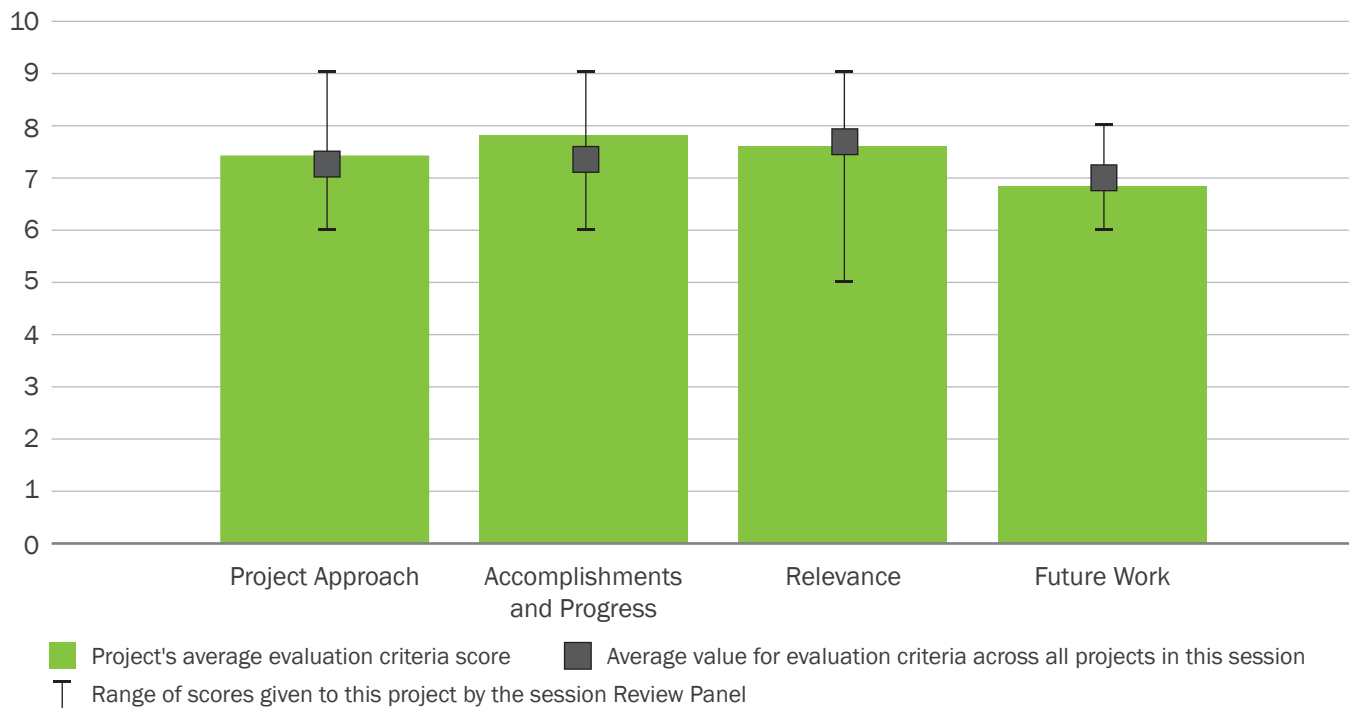

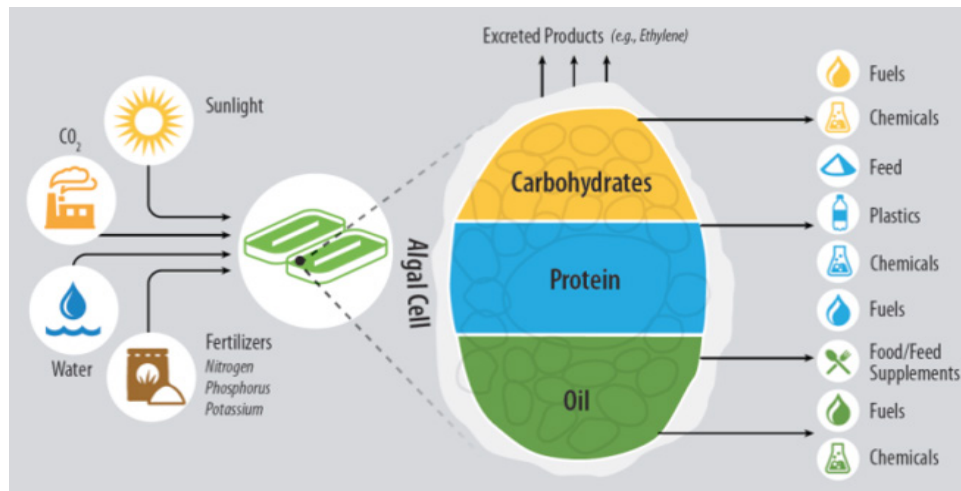

co-products. A biorefinery concept producing hydrocarbon fuels, succinic acid, surfactants, and bioplastics can achieve an MFSP of less than \$3/gge.

Overall Impressions

- This project is a good start on characterizing algal biomass with a goal of providing products into certain higher-value markets. They have made good definitive progress in their stated goals. I would have liked to hear more information on how the project envisioned controlling the culture to optimize their intended composition. They provided some encouraging results toward meeting certain unit cost goals, but I believe considerable more work needs to be done to allow for the creation of a credible TEA.
- This clearly presented project is fleshing out one of the two front-running pathways for bioprocessing of algal biomass to glean maximum value. It is extremely well integrated with other projects, in particular, NREL's TEA and Algal Biomass Valorization efforts, but also serves as the process design basis for many other projects in the portfolio. A myriad of options exists for co-products, and how future directions will be decided is not completely clear.
- Overall, this is an innovative approach that could provide significant impact in regard to large-scale

algal production. By setting up a multi-product pipeline, it allows the farmer to attack various markets as they shift; this will in turn help maintain overall product value while achieving biofuel production goals.

- This project demonstrated the feasible production of several co-products and the necessity of having a portfolio of co-products to ensure target \$/gge is met.
- The project has demonstrated a conversion technology that could significantly improve areal yields of fuels and co-products from algal biomass, which is aligned with BETO MYPP near-term yield goals. The project appears to be on schedule and has achieved many of the stated conversion yield goals. Development of co-product strategies appears promising. It is unclear whether the fermentation portions of the CAP process will be competitive in the marketplace with competing technologies that utilize concentrated glucose feedstocks.

PI Response to Reviewer Comments

- We thank the reviewers for their thoughtful and encouraging comments. Our TEA models suggest that a co-product approach is the only way that MFSP targets can be achieved regardless of the conversion platform. Working with our colleagues in TEA and Algal Biomass Valorization, we have developed a

strategy to identify a broad portfolio of co-products rather than focusing on a single option, spending our resources trying to justify that decision. As noted by reviewers, the portfolio allows for flexibility in decision making for a conceptual algal biorefinery and also allows for better opportunities to develop partnerships with industrial stakeholders.

- It is only in the past calendar year that we have begun to demonstrate feasibility for some of our more promising co-products, such as succinic acid, sterol-based surfactants, and protein-based bioplastics. The shift to biomass from halotolerant strains as feedstock could present unique co-product opportunities that we have not yet identified with *Scenedesmus*. We believe that a strategy of early feasibility studies, coupled with preliminary TEA analyses, will help to identify an integrated process with highest economic potential with least complexity. Detailed TEA modeling is a time- and labor-intensive activity and cannot be easily incorporated into early-scenario casting. However, our initial prioritization was greatly helped by a high-level overview of the potential value of eight different co-product scenarios, allowing us to justify development of detailed TEA models. This provides an optimal list of co-products for a conceptual biorefinery, as well as guidance on how to deploy research resources. Thus, co-products that are promising on a theoretical basis might be rejected in favor of less promising ones that require less developmental work. At the same time, we will continue to leverage process improvements coming from the work of others that would otherwise be out of this project's reach. A case in point is the work done by colleagues on projects within BETO's Conversion R&D Program to isolate an improved strain of *Actinobacillus*

succinogenes, which has shown promise for higher yields on algal sugars (a critical metric). The ABC project does not have the resources to make this sort of improvement, but we will take advantage of such crosscutting opportunities whenever possible.

- But we realize that the time to make an impact with this project is fleeting and that decisions on ideal co-product scenario must be made soon. It is our plan to continue to evaluate new opportunities into FY 2018 and then wrap up (or greatly reduce) the exploratory phase of this project in favor of process development in the areas that can provide the greatest benefit to the overall economics. This will be incorporated into the FY 2018 goal to "Demonstrate all unit operations for conversion of algal biomass to optimal fuels and co-product portfolio for 20% reduction in modeled MSFP relative to FY 2016 SOT."
- Finally, it is important to respond to the criticism that it will be challenging to develop processes with algal sugars that can compete with concentrated industrial sugar feedstocks. It is clear that algal biomass is always likely to be more expensive than terrestrial biomass and thus all components must be valorized to the maximum extent. There are certainly process options that currently require highly concentrated sugar streams, and we have deliberately stayed away from these (e.g., the use of algal sugars to grow oleaginous yeast) for precisely that reason. This is the reason we continue to be interested in ethanol (where the penalty for low titers have been quantified in our TEA model) and succinic acid, which is toxic to the organism at titers much higher than 30 g/L so that concentrated sugars do not provide much of an advantage. We will continue to be guided by TEA to note the economic impacts of titers constrained by low sugar concentrations and develop mitigation strategies where appropriate.

ALGAL BIOMASS VALORIZATION

(WBS #: 1.3.4.300)

Project Description

To drive the critically needed transition from research to commercialization scale, demands increase for rigorous experimentation and characterization to provide the requisite data on biomass products. The isolation of co-products from algae processing routes is the only way to reduce the cost of fuels to \$3/gge by 2022. By implementing an integrated cost-value framework, this task focuses on increasing the intrinsic value of algal biomass. Experimental work is focused on the identification and isolation of key co-products beyond lipid-based fuels in a multi-product algae biorefinery model, commensurate with the Combined Algal Processing conversion process. A second major objective focuses on uncertainties surrounding current harmonized models and productivity assessments; analytical experimental procedures support the generation of verified data to underpin the econom-

Recipient:	National Renewable Energy Laboratory
Principal Investigator:	Lieve Laurens
Project Dates:	10/1/2016–9/30/2019
Project Category:	Ongoing
Project Type:	AOP
DOE Funding FY14:	\$0
DOE Funding FY15:	\$800,000
DOE Funding FY16:	\$850,000
DOE Funding FY17:	\$750,000

ic base case and set realistic process and cost targets for future strain improvements. Similarly, robust data are needed to assess progress toward the targets using standardized measurements. This task publishes experimentally validated procedures that can advance the field of algal biofuels with reference analytical methods, data for techno-economic modeling, and analysis and help set quantitative metrics for process and strain improvement strategies.

Weighted Project Score: 8.1

Weighting: For ongoing projects, there is equal weighting across all four evaluation criteria: Approach, Relevance, Accomplishments and Progress, and Future Work.

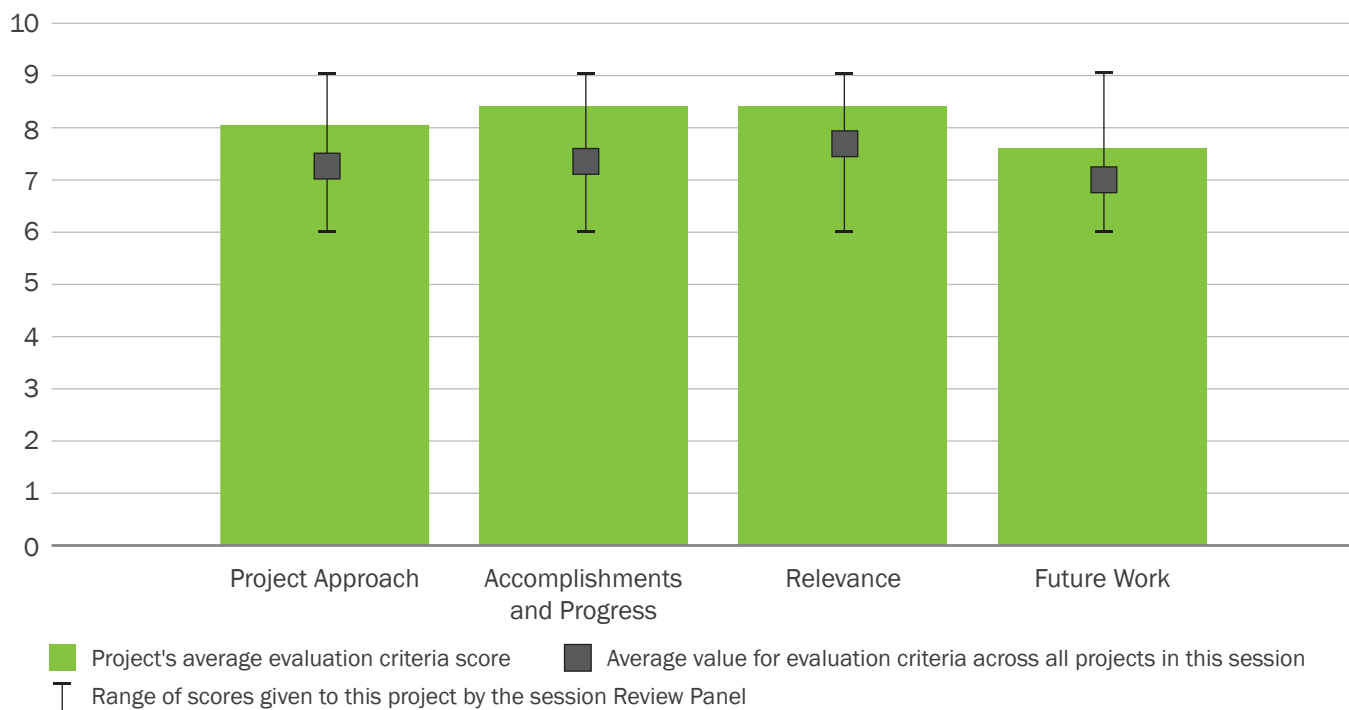

Overall Impressions

- The identification and extraction of valuable co-products is critically important for advancing the economic viability of this industry. The approaches and methodology for identifying valuable co-products and doing initial work on the economics is a good start. Additional work on the capture and purification of the co-products and harvest strategies would be good ongoing work.
- This continues to be one of the essential core projects in the portfolio. Expansion into algal biomass valorization via co-products is taking advantage of the core expertise of this group and providing assistance to many other projects, both within BETO's portfolio and within the algal community in general. Close interactions with TEA modelers and industry are essential as this project moves forward.
- Overall, this project has the potential for significant impact and importance within the field of scaled algae production. The potential impact of the standardization of metrics and process is very great and could help to harmonize information across the industry.
- Full biomass valorization and the measurement methods required to achieve it give important direction and tools to both research and industry for maximizing the potential of algal biomass.
- This project has made strong contributions to method standardization across the algal industry. The team should be commended for their methods work, as well as stakeholder engagement and outreach efforts (both for input and information dissemination). Efforts related to co-product development and market analysis are highly relevant to BETO MYPP goals to achieve \$3/gge selling price for algal biofu-

els. The team is encouraged to engage with industry in future co-product development efforts to ensure co-product TEAs capture appropriate regulatory compliance and downstream-processing costs.

PI Response to Reviewer Comments

- We appreciate the complimentary remarks by the review team and welcome the opportunity to respond. Overall, the comments reflect a deep understanding by the reviewers of the critical value this work brings to the algae bioeconomy and in particular of how this project is helping to drive down the cost of algal biofuels and bioproducts. As we move forward in the experimental work for this project, we will address the points brought forward by the reviewers in that we will continue to engage industrial partners to help prioritize products and pathways and, ultimately, to help shape the regulatory landscape where it is applicable.

Quantitative pursuit of the feasibility and cost assumptions for isolation and purification of products is a standard part of our detailed TEA modeling. As we move forward with the development of promising new co-product options, we will work those, with their respective purification pathways, into our models. Simultaneously, we will integrate a detailed cost-value framework around cultivation productivity and the respective trade-offs in biomass composition. This will allow us to more fully understand and optimize opportunities for algal biofuels and bioproducts over a range of cultivation conditions. Ultimately, we are driving this work toward a fully transparent and open framework for the integrated algae biorefinery concept and multi-product pathways, and we look forward to a continued collaboration with BETO and commercial partners.

PRODUCING TRANSPORTATION FUELS VIA PHOTOSYNTHETICALLY DERIVED ETHYLENE

(WBS #: 1.3.4.301)

Project Description

Ethylene is the most widely produced petrochemical feedstock globally and a potential fuel intermediate. It is currently produced from fossil resources, and its production via steam cracking is the largest CO₂-emitting process in the chemical industry. A potentially more sustainable alternative is a biological process that converts CO₂ to ethylene by photosynthesis. The efe gene encoding an ethylene-forming enzyme was expressed in the cyanobacterium *Synechocystis* 6803, leading to continuous ethylene production. Ethylene production can be supported by seawater. The productivity has been increased by enhancing efe expression levels, such that up to 20% of photosynthetically fixed carbons are redirected from

Recipient:	National Renewable Energy Laboratory
Principal Investigator:	Jianping Yu
Project Dates:	10/1/2015–9/30/2018
Project Category:	Ongoing
Project Type:	AOP
DOE Funding FY 2014:	\$0
DOE Funding FY 2015:	\$150,000
DOE Funding FY 2016:	\$400,000
DOE Funding FY 2017:	\$400,000

biomass growth to ethylene formation in simulated diurnal light conditions. Despite losing carbons as ethylene, biomass growth is not affected, indicating stimulation of photosynthesis. Detailed characterization using metabolic flux analysis identified global adjustments in carbon and energy metabolism. Both light reactions of photosynthesis and carbon uptake are stimulated by ethylene production. We are trying to identify and overcome current rate-limiting step, presumed to be the supply of arginine, which is a substrate of an ethylene-forming enzyme. A

Weighted Project Score: 6.6

Weighting: For ongoing projects, there is equal weighting across all four evaluation criteria: Approach, Relevance, Accomplishments and Progress, and Future Work.

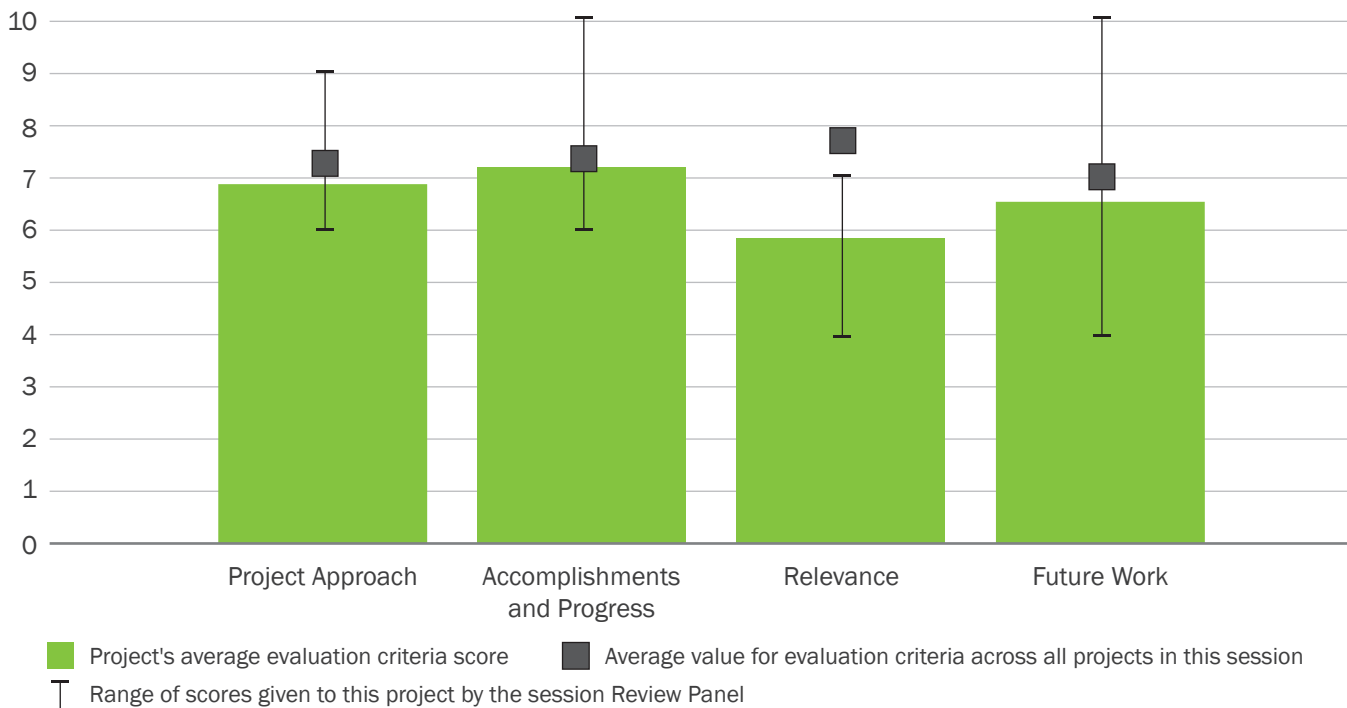

process design and cost model is under development to drive future studies. Co-product guanidine, a versatile intermediate and fertilizer, is found to accumulate in the culture medium.

Overall Impressions

- The production of ethylene does not appear to directly advance the goals of the MYPP in terms of biofuel or biomass production (although ethylene can be converted to liquid fuels that are not the highest-value product). However, if this technology can be advanced to the commercial stage the benefits will be meaningful in terms of reducing petroleum usage for the production of products and providing an economically sustainable avenue for the development of methods and facilities for cultivating and processing cyanobacteria. After being over half done with the project, their carbon flux toward ethylene is very low. Their future work includes the use of PBRs and separation membranes. I believe they should put the PBR and membrane work on hold until they can significantly improve the production toward ethylene.
- This is an exciting concept that certainly has potential as a direct photobiological chemical production system. However, the vision of this concept at scale is still lacking many important details, and the economic feasibility has only been examined to a very rudimentary level. The guanidine co-product scenario being explored may or may not be feasible, and product purification (of ethylene and guanidine) needs to be worked out. Further dialogue with industry is essential.
- Overall, this project is very conceptual in nature and may provide a very interesting aside as to what alternative pathways there are to achieve the overall

programs goals and deliverables. Continued investigation as to the merit of how this system will be deployed commercially will help to illustrate its viability to meet BETO's goals and deliverables.

- This is very exciting work, but more consideration needs to be given to commercialization.
- Significant knowledge has been generated regarding engineered metabolism toward ethylene production as a result of this project and should be commended. There may be issues with the economics for large-scale production, particularly if guanidine is to be used as a co-product as methods to harvest soluble guanidine haven't been developed.
- If successful, the project could result in a bio-based alternative to one of the most widely produced petrochemicals, as well as co-products and biofuels. The project approach appears to involve a number of high-risk, high-cost components even if the team is successful in achieving target production rates of ethylene, co-products, and biomass. It is unclear if the TEA accurately accounts for these costs.

PI Response to Reviewer Comments

- We sincerely appreciate all of the valuable comments and constructive suggestions. We strongly agree that strain development (to further improve productivity and carbon partition) and process development (to test ethylene production from bench to large-scale PBRs) remains the focus of our R&D efforts, while TEA remains an important tool to guide future R&D with integrated assessment of the overall process concept. As mentioned in slide 21,²² the strain development effort is centered on identification of rate-limiting step and subsequent genetic modification. The process development effort stud-

²² Jianping Yu, "Producing Transportation Fuels via Photosynthetically Derived Ethylene" (presentation given at the Bioenergy Technologies Office 2017 Project Peer Review, Washington, DC, March 8, 2017), https://energy.gov/sites/prod/files/2017/05/f34/algae_yu_134301.pdf.

ies PBR operation targeting for a deployable production system particularly suitable for ethylene and other co-product production. Both efforts are needed to move the technology forward, including meeting our FY 2017 year-end milestone—a 50% increase in ethylene productivity in PBR. We also plan to have a TEA milestone in FY 2018 to incorporate ethylene, guanidine, and biomass valorization.

As algae platform research shifts from lipid-based biodiesel production to more integrated biorefinery with fuels and chemicals, high-value co-product is key to achieving \$3/gge. This is also true for the cyanobacterial ethylene project. The project team will expand to study alternative, more integrated process concepts beyond just making ethylene for upgrading to transportation fuels. For example, an integrated biorefinery can photosynthesize CO₂ to ethylene, while also converting ethylene to value-added co-product; converting cyanobacterial cell biomass to renewable diesel blendstock, proteins, pigments, and other co-products; and harvesting guanidine and upgrading it to value added co-product. Guanidine accumulation in media was discovered only a few months ago. Guanidine salts can be major components of fertilizer or rocket fuel, among many other uses. Our engineering efforts will include purification of guanidine and converting it to high-value co-product. Guanidine can be converted to desired guanidine salts by reaction with a strong base, such as an alkali metal hydroxide or methoxide. The guanidine salts can then be separated from the solution by crystallization for high purity. Iron exchange column may be an alternative method to harvest guanidine based on its positive charges.

The success of this project (high-impact publications, patent, and major awards) has attracted collaborators from both academia and industry, maximizing the impact of BETO funding. Collaboration with industry has influenced this project in many ways. Our TEA manuscript received valuable feedback from major chemical and algal companies. We recently started to collaborate with a company on larger-scale cultivation located at ASU using tubular reactors. We have also collaborated with an algae cultivation company on attached growth, and with Colorado State University on thin film reactors. Ultimately, we will test various PBRs in order to (1) understand feasibility and robustness of continuous cultivation and harvesting of the main product and co-products for targeted productivity, yields, or carbon flux; (2) enhance both our and BETO's knowledge base for commercialization strategies; and (3) ensure technology development following the path toward a viable process. On product harvesting, we have been working with a company on membrane separation of ethylene. Moving forward, the process development effort will include co-product production/credits, PBR cost, gas-phase separation cost, and separations of dissolved products, and will be studied in collaboration with industrial partners.

As a component of the NREL algae platform, we are planning to coordinate with other projects and take advantage of our compositional analysis capabilities, as well as newly updated PBR designs and costs by the algae platform analysis team. We will look for opportunities and potential application of the reported PBRs to ethylene and co-products production.

ALGAE TESTBED PUBLIC-PRIVATE PARTNERSHIP (ATP3)

(WBS #: 1.3.5.100)

Project Description

The goal of ATP3 is to establish a sustainable network of regional testbeds that empowers knowledge creation and dissemination within the algal research community, accelerate innovation, and support growth of the nascent algal fuels industry. ATP3 increases stakeholder access to high-quality facilities (Function 1) by making an unparalleled array of outdoor cultivation, downstream-process equipment, and laboratory facilities available, along with world-renowned expertise from a tightly managed multi-institutional and transdisciplinary team. ATP3 utilizes a powerful combination of facilities, technical expertise, and proactive management structure to support DOE’s techno-economic, sustainability, and resource

Recipient:	Arizona State University
Principal Investigator:	John McGowen
Project Dates:	1/31/2013–12/31/2017
Project Category:	Ongoing
Project Type:	FY 2012—Advancements in Sustainable Algal Production (ASAP): DE-FOA-0000615
Total DOE Funding:	\$14,999,658

modeling and analysis activities, helping to close critical knowledge gaps and inform robust analyses of the SOT by conducting coordinated, long-term cultivation feedstock trials at ASU’s geographically diverse sites to provide a unique data set regarding reproducibility, scalability, seasonal, and environmental variability (Function 2). These data are critically important to support TEA and LCA activities that will guide R&D toward the transformative goal of cost-competitive algal biofuels by 2022.

Weighted Project Score: 8.8

Weighting: For ongoing projects, there is equal weighting across all four evaluation criteria: Approach, Relevance, Accomplishments and Progress, and Future Work.

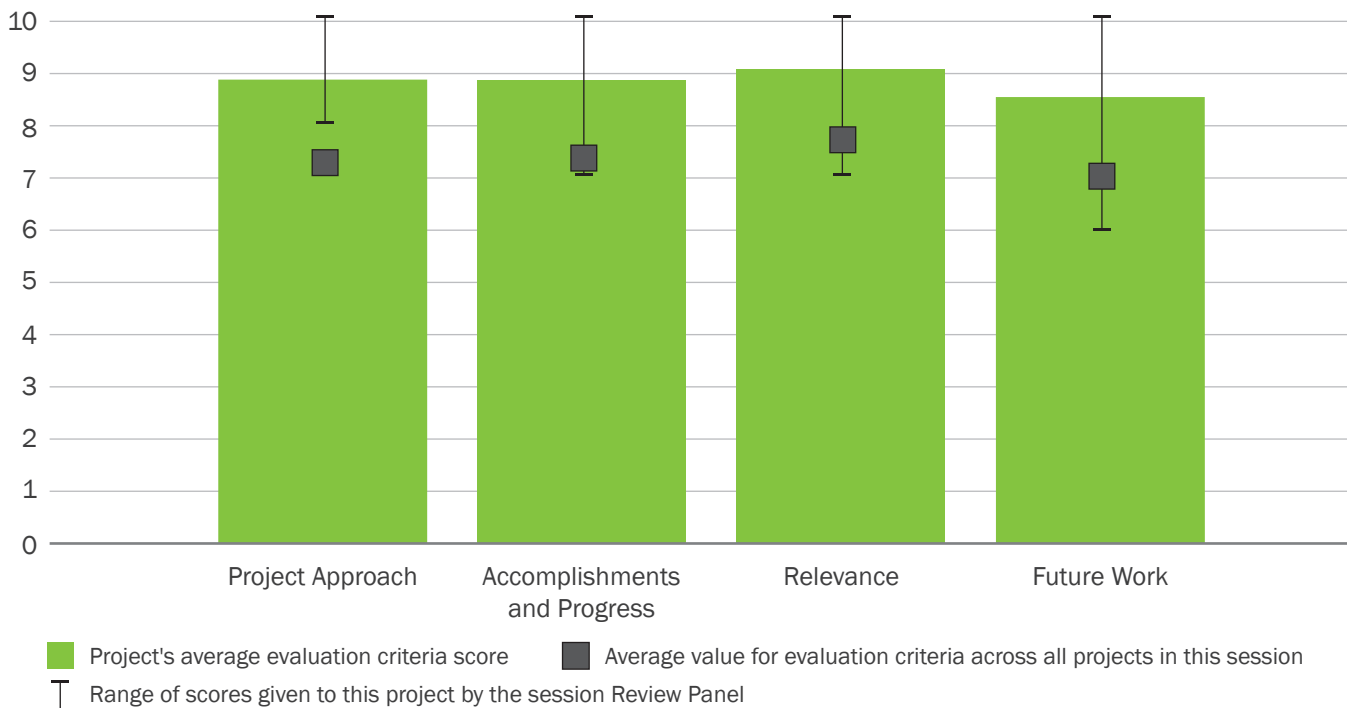



Overall Impressions

- This is a flagship effort for the algae industry, for both academia and industry. Excellent progress has been made in advancing protocols, methodologies, and training, and in being a reliable testbed. It appears to me that private funding for this facility may be necessary in the future. If they have not already done so, the project should consider providing third-party-verification services where vendors can have their equipment or processes verified by ATP3 (ATP3 personnel run the equipment, not the vender).
- ATP3 is serving a vital role in supporting the stakeholder community. Its record of high productivity and the feedback from stakeholders speak to the fundamental value of this project. It would be a serious loss to the community if this function were no longer available, and it seems too early in the evolution of the industry to expect this work to be self-supporting.
- Overall, the ATP3 testbed has provided a valuable resource to the algal production industry. The ATP3 team has helped move the industry forward and provide a valuable service to companies needed to test and prove technologies.
- A sustainable network of regional testbeds is required to continue the work on improvements to meet MYPP goals. Multi-regional, long-term field

trials with publicly available and widely shared data are critical to achieving the goals set in the MYPP. Demonstration in outdoor conditions is critical not just for productivity, but for demonstration of viability of co-product production, providing biomass for downstream development, method development, method harmonization and variation reduction, etc.

- ATP3 is a keystone effort within the BETO portfolio and integral to the success of several other projects funded by BETO. The kind of standardization achieved and aimed for by ATP3 is essential for generating data and setting baselines that will drive the industry forward. The project should continue to develop standardization metrics to ensure a high quality of reproducibility moving forward.
- The project has had broad stakeholder engagement, with over 40 clients and 60 projects in 4 years. The testbed has engaged a mix of national labs, academics, and industry, and has served as a primary source of data for BETO's SOT for empirical data feeding into TEA efforts. The project has achieved major milestones and critical success factors. The project accomplished education and training goals and effectively served the broad stakeholder community, including a long list of collaborators.

PI Response to Reviewer Comments

- We appreciate the comments and look forward to continued dialogue with BETO's Advanced Algal Systems team about how we can continue to be a resource for the algae stakeholder community. Through critical focus areas such as Standards Development and Deployment; High-Impact Data from Lab-to-Field-to-Lab studies at pilot scales that support SOT assessments; and Open-Access Testbed(s) Education and Training for Workforce Development and Outreach activities, we are a key resource for R&D and technology and business risk reduction.

We feel there is significant value in the partnership established under ATP3 and that there are several

critical capabilities lost if future support for the testbeds is not secured, including the following:

- SOT support with year-over-year integration/objective validation of
 - Cultivation systems improvements/testing
 - Geographic variability/seasonal variability
 - Quantitation of annual operating days
 - Pond contamination and reliability monitoring.
- National lab access to outdoor testing for validation of lab-based R&D.
- Access to facilities for validation/due diligence/standards for industry and early-stage technology company support.
- Standardized, genetically modified algae outdoor testing facilities.
- Workforce development through an established program centered on access to facilities; ATP3 is the only hands-on workshop providing participants access to outdoor cultivation facilities.

The ATP3 network is the first-ever demonstration of the value of implementation of standardized analytical and process-monitoring methodology across a multi-institutional group of researchers. We built on years of experience in developing and validating procedures,²³ and throughout the ATP3 project the implementation, training, and quality control of data was refined and is the subject of two recently accepted manuscripts to be published in *Algal Research* (Lieve M.L. Laurens et al. and John McGowen et al., *Algal Research* 2017; in press). This approach has been well received by the community, and at least two newly funded consortium projects

are implementing a similar approach. Standardization is critical to a nascent industry establishing itself and achieving long-term viability. We are very proud of the efforts we have put in to our own standardization activities and look forward to continued stakeholder engagement on this topic.

The ATP3 testbed network provides easy access for researchers to an outdoor testbed site to validate and capitalize on improvements made in the laboratory, such as with genetically engineered strains, and provide established methodology and an easy cost structure that is invaluable to the support for the burgeoning algae industry in which different technologies can be road-tested and compared and technology and business risk reduced. We are eager to continue in that support role. And while we were not able to go into detail in our presentation, third-party validation is a key offering for ATP3 and in fact is something that we have already done and is part of the revenue we reported.

The investment BETO has made over the past 4 years has built a unique research group with demonstrated ability to carry out complex algae cultivation experiments, broadly increase access to outdoor cultivation facilities, and implement robust education and workforce development programs. We have provided robust, reliable, publicly available and outdoor algae cultivation, harvest, composition, and pond ecology and pathology data for SOT assessments and decision support for BETO's Advanced Algal Systems Program and are uniquely suited to continue to serve that platform. Reconstituting this capability in the future will be costly and time consuming, and we continue to pursue opportunities to remain active in this role.

²³ See: (1) Lieve M. L. Laurens, Thomas A. Dempster, Howard D. T. Jones, Edward J. Wolfrum, Stefanie Van Wycken, Jordan S. P. McAllister, Michelle Rencenberger, et al., "Algal Biomass Constituent Analysis: Method Uncertainties and Investigation of the Underlying Measuring Chemistries," *Analytical Chemistry* 84, no. 4 (2012): 1879–87, doi:[10.1021/ac202668c](https://doi.org/10.1021/ac202668c). (2) Lieve M. L. Laurens, Stefanie Van Wycken, Jordan P. McAllister, Sarah Arrowsmith, Thomas A. Dempster, John McGowen, and Philip T. Pienkos, "Strain, Biochemistry, and Cultivation-Dependent Measurement Variability of Algal Biomass Composition," *Analytical Biochemistry* 451, no. 1 (2014): 86–95, doi:[10.1016/j.ab.2014.02.009](https://doi.org/10.1016/j.ab.2014.02.009). (3) Stefanie Van Wycken, William Long, Stuart K. Black, and Lieve M. L. Laurens, "MBTH: A Novel Approach to Rapid, Spectrophotometric Quantitation of Total Algal Carbohydrates," *Analytical Biochemistry* 518, no. 1 (2017): 90–93, doi:[10.1016/j.ab.2016.11.014](https://doi.org/10.1016/j.ab.2016.11.014).

REGIONAL ALGAL FEEDSTOCK TESTBED (RAFT) PARTNERSHIP

(WBS #: 1.3.5.111)

Project Description

The overall goal of the RAFT Partnership is to obtain long-term cultivation data that is model driven. The project is a collaboration between the University of Arizona, PNNL, New Mexico State University, and Texas A&M AgriLife Research. Our approach is to characterize the growth rates of production strains as a function of light, temperature, and salinity. This data is then given to modelers to predict and design a crop-rotation strategy for the testbeds. Each testbed implements the rotation strategy to obtain cultivation data. RAFT researchers have grown three strains over three seasons in three sites. The team has also cultivated algae in recycled media and wastewater. All data will be publicly available at <http://www.algaeknowledge.org>. Additional work involves quantitative

Recipient:	University of Arizona
Principal Investigator:	Kimberly Ogden
Project Dates:	9/1/2013–8/31/2017
Project Category:	Ongoing
Project Type:	FY 2012—Advancements in Sustainable Algal Production (ASAP): DE-FOA-0000615
Total DOE Funding:	\$8,000,001

polymerase chain reaction data to monitor contaminants and development of an online optical density sensor to continuously monitor algal growth.

Overall Impressions

- This project is providing good baseline-type data that other projects can start with. In addition to their stated goal of cultivating algae year-round outdoors, this project has also developed operating procedures to help improve productivity, reduce downtime,

Weighted Project Score: 7.4

Weighting: For ongoing projects, there is equal weighting across all four evaluation criteria: Approach, Relevance, Accomplishments and Progress, and Future Work.

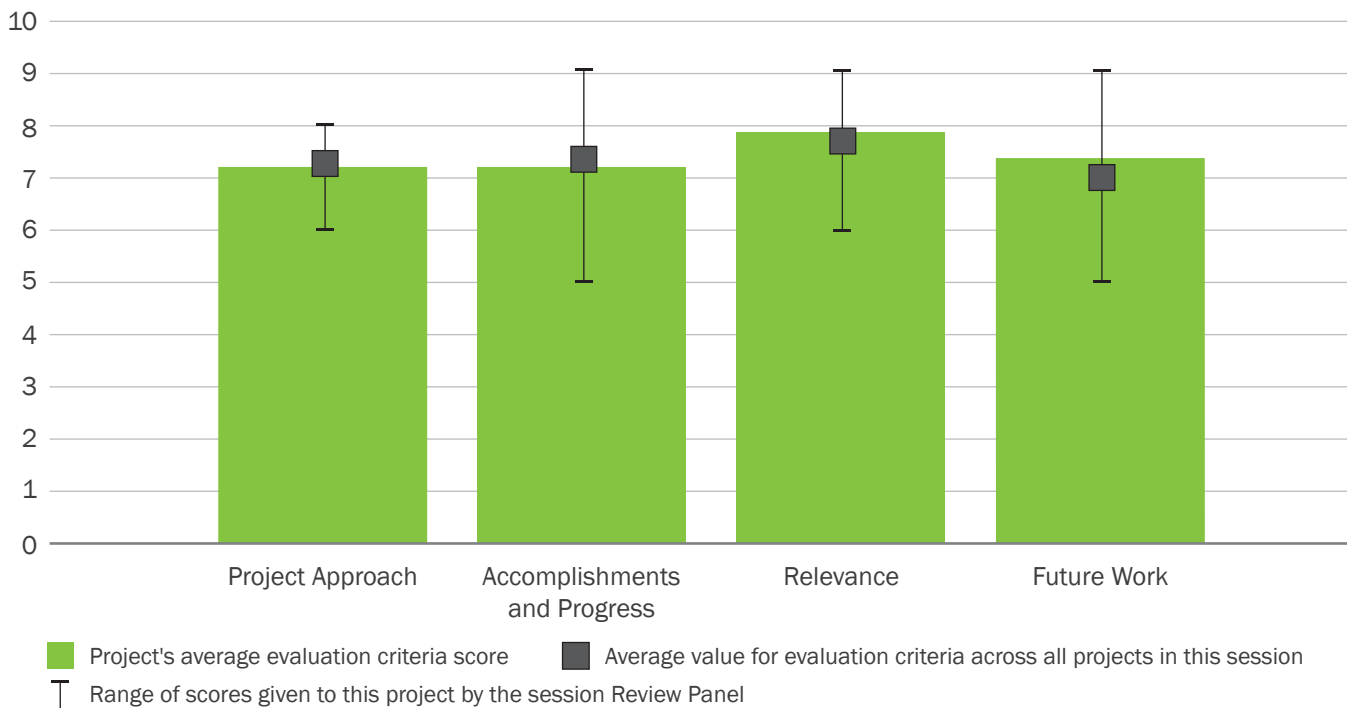

and detect contaminants. This project has developed equipment and procedures that I assume will be available for industrial use. It would be good if this program coordinated with ATP3 on developing and agreeing to standard operating and analytical procedures.

- This project casts a wide net. Useful data on the SOT, pond crashes, seasonal strain performance, etc., have been collected. Defined, unifying goals are lacking, and reviewers' concerns from the 2015 Project Peer Review regarding lack of interaction with the algae community have not been fully addressed.
- Overall, the RAFT project and team have combined to provide relevant algal production data over the course of the project. The information generated can and will provide important information as to the processes of scaling algal biomass production systems and integrating various species and pond designs in different locations.
- Multi-location, multi-season field trials for validation of Biomass Assessment Tool and other tools combined with the pond ecology work demonstrates that these collaborative field trial efforts are critical to continue productivity improvements. This is required to meet the productivity goals in the MYPP.

- RAFT is generating real productivity measurements and dealing with problems that arise during cultivation at scale in different environments, making it a valuable effort toward developing systems for sustainable production of algae fuels. The data management system currently being developed will be useful for transparency in sharing data and moving the industry forward.
- The project is making strong contributions to publicly available, large-scale outdoor production tests at multiple locations. The project has resulted in several pond-monitoring and crop-protection improvements, and biomass produced has been used by a number of groups for downstream-process testing and product development. The team has made a strong commitment to making publicly available data sets user-friendly and will continue to improve data accessibility moving forward.

PI Response to Reviewer Comments

- A near-term goal is to send biomass to NREL to determine how well our techniques for determining ash-free dry weight, protein, carbohydrate, and lipid compare with theirs, and then we can have a discussion regarding standard operating and analytical procedures.

Thank you for your feedback, both written and in person at the Project Peer Review.

DEVELOPMENT OF ALGAL BIOMASS YIELD IMPROVEMENTS IN AN INTEGRATED PROCESS – PHASE II

(WBS #: 1.3.5.211)

Project Description

GAI’s Phase 1 project resulted in tremendous productivity and processing improvements that have moved algal technology closer to economic viability for biofuels than ever before. This project builds on these successes to accelerate the commercialization of algal biofuels. Best-in-class cultivation and processing technologies are being combined in some of the world’s leading strain development laboratories to develop yield and energy use improvements. Yield improvements will come from better strains generated by world-class algal strain developers and from open-pond cultivation innovations.

Recipient:	Global Algae Innovations Inc. (GAI)
Principal Investigator:	David Hazlebeck
Project Dates:	10/1/2016–9/30/2019
Project Category:	New
Project Type:	FY 2016—Advancements in Algal Biomass Yield Phase 2 (ABY2): DE-FOA-0001471
Total DOE Funding:	\$6,250,000

Energy use improvements will come from new drying and extraction unit operations.

Two parallel pathways to a biofuel are being investigated. In the crude oil pathway, an algal slurry is converted to oil and an aqueous recycle stream via hydrothermal liquefaction. In the lipid oil pathway, the algae biomass slurry is dried, and oil is extracted to produce lipid oil and a high-protein algae meal co-product. Generally, the algal lipid oil pathway has lower productivity because of the need to accumulate lipids, but it has better

Weighted Project Score: 8.1

Weighting: Approach–25%, Relevance–25%, and Future Work–50%.

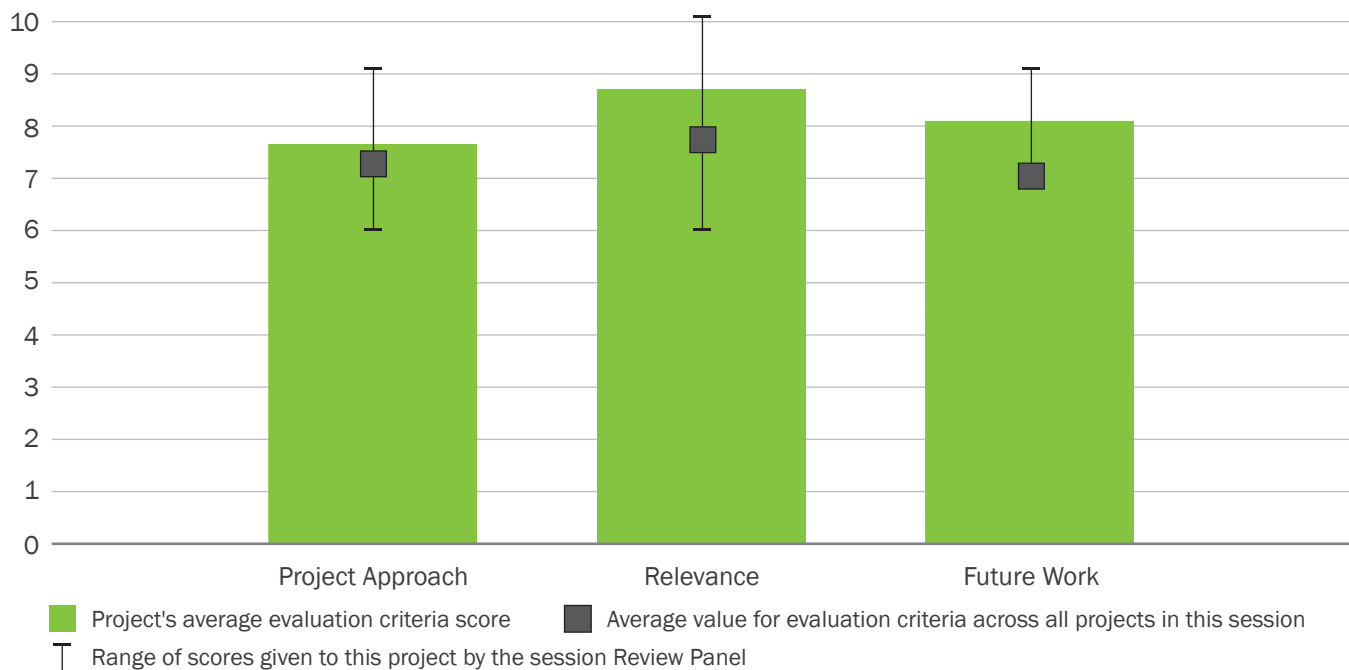



economics because the lipid oil is higher quality than crude oil and a protein meal co-product is produced. The productivity goals for the project are 5,000 and 8,000 gallons per acre per year for the lipid and crude oil pathways, respectively. The energy use reduction goals for this project are 58% and 19% for the lipid and crude oil pathways, respectively.

Overall Impressions

- The advances are very encouraging in terms of pond design, operating procedures, and equipment development. The development of a full TEA with independently validated technical inputs will be important for determining the future of these advancements as a whole.
- The lack of detail presented in project approach and future work is understandable for a for-profit entity, but it makes evaluation difficult. Ambitious metrics have been set, and the comprehensive approach that addresses every facet of the process will likely result in significant advances.
- Overall, this is a solid project with a solid team of investigators. By doing most of the work at a

commercial scale, data and information can be directly translated to provide clarity into further TEA assessments. Optimization of CO₂ stream into the production systems show significant promise for the improvement of productivity while reducing overall facility capital cost.

- The integrated approach is useful; viewing process from end to end allows for synergies between unit operations. Continued iterative optimization of ABY1 technologies and improvements, with a focus on energy reduction, will hopefully lead to additional similar breakthroughs as in ABY1.
- The proposed project has a clearly defined plan for strain improvements, cultivation improvements, and efforts to decrease downstream-processing energy. The team has a track record of meeting project goals within proposed timelines and budgets. The work will be executed in an integrated, industrial environment and has clear relevance to industry, as well as BETO MYPP goals.

PI Response to Reviewer Comments

- This project builds on the success of the ABY1 effort with ambitious goals that will require development of new transformational technologies. The approach is to combine best-in-class cultivation and processing technologies with some of the world's leading strain development laboratories to develop yield and energy use improvements. All of the technologies are filtered through a comprehensive techno-economic model so that only work is restricted to approaches that will contribute to formation of an economically viable, sustainable algae commodities industry that can provide oil for drop-in biofuels.

BIOMASS PRODUCTIVITY TECHNOLOGY ADVANCEMENT TOWARDS A COMMERCIALY VIABLE, INTEGRATED ALGAL BIOMASS PRODUCTION UNIT

(WBS #: 1.3.5.220)

Project Description

Sapphire Energy Inc. (Sapphire) has developed an end-to-end process to produce renewable, algae-based fuel that is fungible with existing refinery streams. The project addresses three priority areas: (1) improve algal biomass productivity in outdoor cultivation environments relevant to commercial scales, (2) improve preprocessing technologies that can be integrated at scale with biomass production, and (3) successfully integrate priority areas 1 and 2 to ensure that target yields are met at a scale that enables production of cost-competitive fuels and prod-

Recipient:	Sapphire Energy Inc.
Principal Investigator:	Craig Behnke
Project Dates:	10/1/2013–8/31/2016
Project Category:	Sun-setting
Project Type:	FY 2013—Advancements in Algal Biomass Yield (ABY1): DE-FOA-0000811
Total DOE Funding:	\$5,000,000

ucts. In meeting each of these objectives, Sapphire aims to demonstrate sufficient improvements in algal biomass yield at lab and outdoor pilot scales to provide a positive indication toward success of a 1-acre demonstration of 2,500 gallons per acre per year oil productivity by 2018. In a highly integrated process, Sapphire aims to increase intrinsic algal biomass productivity by employing evolution-based strain engineering and developing a systems biology approach to identify the regulatory networks associated with controlling both biomass productivity and oil content. To improve its cultivation process, Sapphire is

Weighted Project Score: 7.8

Weighting: Approach–25%, Relevance–25%, and Accomplishments and Progress–50%.

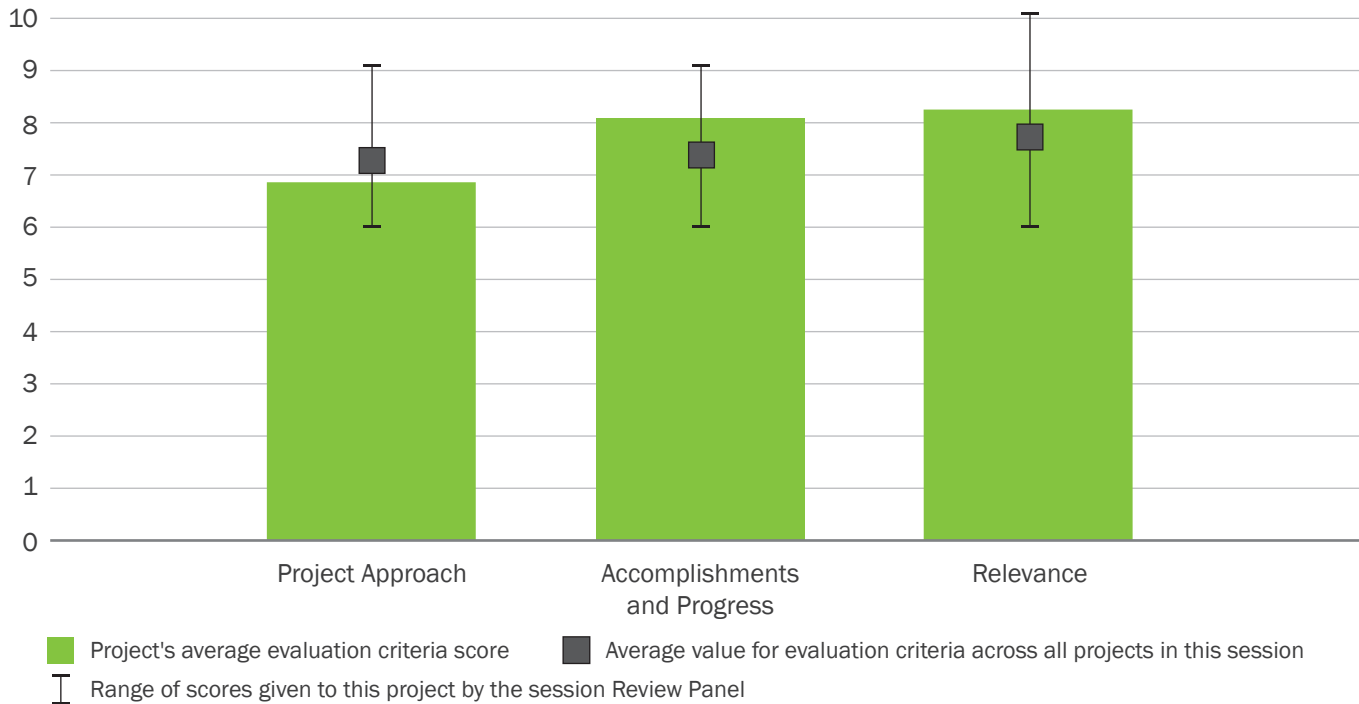

constructing ecologies to minimize yield loss in the ponds by increasing robustness across biotic and abiotic stresses. Improvements are also developed in nutrient recycle, harvest and extraction, and hydrothermal treatment and extraction methodologies by increasing efficiency and decreasing cost.

Overall Impressions

- This is a well-executed project. The project considered many of the factors other projects are trying to address in more detail. Great approach and demonstration at larger scale out of doors and for an extended period of time. This project demonstrated exceeding the MYPP goal of 2,500 gallons per acre in an outdoors raceway and reduced the estimated cost to \$5.20/gge from their baseline of \$7.60. I believe the TEA was done with the cost of de-metaling the HTL oil included. In the presentation, the HTL was done at severe conditions of 400oC and 60-minute residence time. If the severity was lessened with corresponding oil yield loss, I assume the cost for treating the HTL oil would decrease as the oil quality improves. How would this “better oil” at a lesser yield impact the TEA? I believe other projects assuming upgrading of HTL oils would benefit from this presentation and an understanding of what a refinery might be willing to accept as a feedstock.
- The lack of specifics presented (due presumably to both time/space considerations and proprietary data) make it difficult to assess the specific approaches and accomplishments. However, it appears that the overall productivity goal was reached. Valuable lessons were learned, including the importance of HTL oil quality for acceptance by refiners. It is hoped that these lessons will become available to the greater community through publications.
- Overall, this project shows good lab-to-field testing and implementation. Lessons learned in the field with larger-scale growth trails can lend to significant improvements in large-scale culture optimization.
- This project demonstrated impressive advancement in crop protection, leading to increased crop stability.
- The project appeared to meet many stated technical targets, including productivity improvements leading to a demonstration that exceeded BETO’s MYPP goals for areal production (2,500 gallons per acre per year by 2018). The project has clear relevance to the algal biofuels industry and virtually all work has been completed.

PI Response to Reviewer Comments

No official response was provided at the time of report publication.

REALIZATION OF ALGAE POTENTIAL (REAP)

(WBS #: 1.3.5.230)

Project Description

The goal of the REAP R&D program is to develop an integrated process for producing at least 2,500 gallons of biofuel intermediate per acre per year within 30-months (Performance Period 1). This outcome will advance the DOE goal of demonstrating 5,000 gallons per acre per year by 2022. We take a translational approach, building on only the most promising technology options for each unit operation. The focus is on implementation and integration driven by cost, scale-up potential, and energy-balance design criteria. Process integration trials will occur at ASU's algal cultivation testbed. This work will produce engineering data for system modeling so that those data will be coherent and integrable. Simultaneously, REAP

Recipient:	Arizona State University (ASU)
Principal Investigator:	Pete Lammers
Project Dates:	9/30/2013–3/31/2016
Project Category:	Sun-setting
Project Type:	FY 2013—Advancements in Algal Biomass Yield (ABY1): DE-FOA-0000811
Total DOE Funding:	\$5,000,000

members at Washington State University will explore improvements to oil production by sequential HTL; work at Los Alamos National Laboratory will improve strains; work at PNNL will validate quantitative growth models required for resource assessment modeling; work at Pan Pacific Technology and Argonne National Laboratory will produce energy- and material-balanced system models in Aspen based on the REAP process data; and work at Algenol Biofuels will support cultivation studies and provide assistance for techno-economic readiness.

Weighted Project Score: 6.8

Weighting: Approach–25%, Relevance–25%, and Accomplishments and Progress–50%.

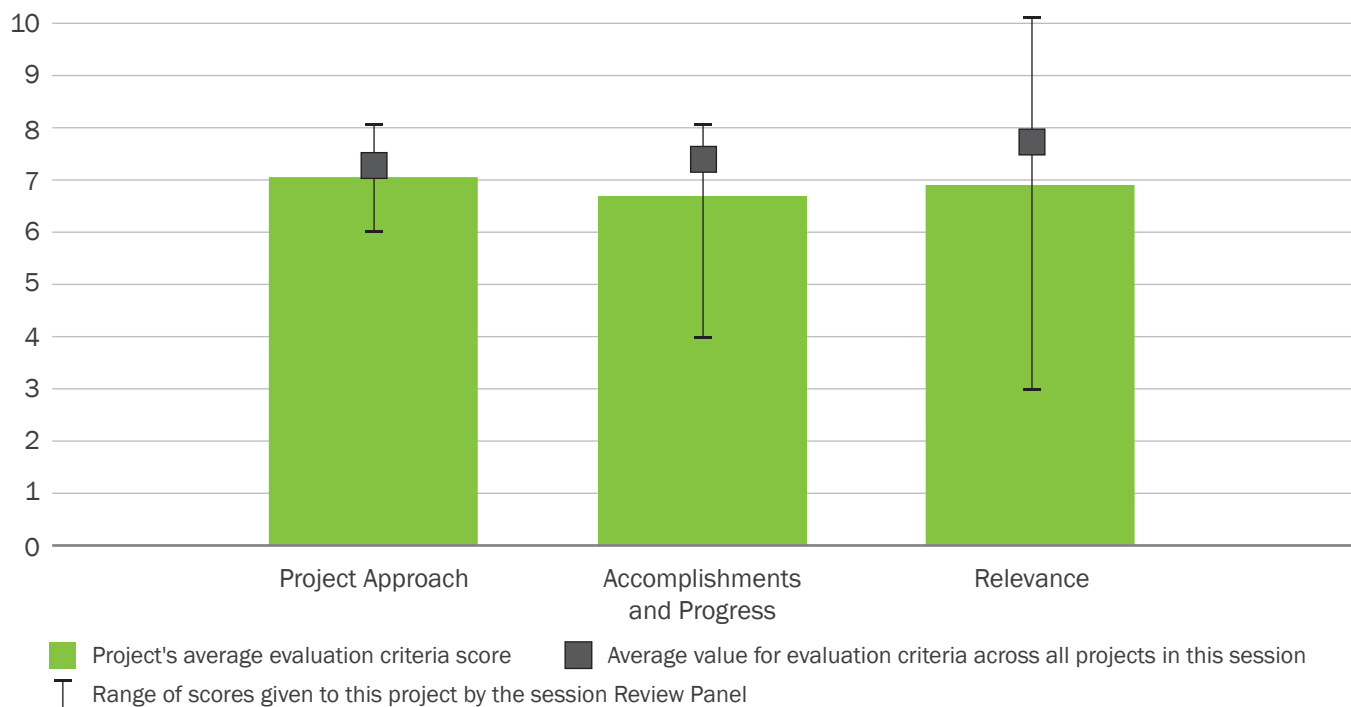

Overall Impressions

- I think the TEA of this project would benefit greatly from including a reputable member of industry practiced in upgrading oils to make them suitable as a refinery feedstock. The industry partner should advise on the cost of upgrading (including the removal of metals) the different oils generated by different HTL operating conditions to make them acceptable to a refiner and at what discount the refiner would want in order to take the oils.
- This project explored important issues across the entire process. Perhaps it was a failing of the presentation rather than the actual work, but it is not clear what, if any, important takeaways resulted from this work. The demonstration of a novel mixotrophy strategy did result in funding of a new project.
- Overall, this project has shown some interesting and relevant results that should provide some significant impact on further development.
- This project was well executed and demonstrated that more than 5,000 gallons per acre per year is feasible in a PBR system using mixotrophy, as well as over a year of stable cultivation with multiple crop rotations (called strain switches in the presentation).
- Somewhat marginal progress was made in strain improvement during this project; however, the hallmark accomplishment of this project was mixotrophic cultivation in outdoor PBR systems that improved productivity above targets. This is a new accomplishment since the last review, making this an overall successful endeavor/partnership.
- The team presented a clear management and technical plan and achieved several of the project's original goals. Long-term stability of heat-tolerant cultures was demonstrated, and high-density harvests were possible with mixotrophy. Productivities exceeded BETO MYPP goals, although it is unclear if areal productivities using mixotrophic approaches

are meaningful for these targets. The TEA suggested that BETO MYPP biofuel cost targets could not be met with this approach.

PI Response to Reviewer Comments

- The team acknowledges the broad scope of the REAP project. There are several important project conclusions that may have been underemphasized in the presentation. The ABY1 program goal for areal fuel feedstock yield was achieved (or missed by a small margin). This was accomplished with wild-type organisms in PBRs operated continuously without culture failures for more than 1 year. Mixotrophy was then shown to provide a route to 6,700 gallons of biocrude per acre per year, more than double the ABY1 yield goal and more than the 2022 goal of 5,000 gallons per acre per year.
- Obstacles to transformation were overcome and genetically improved strains are now in the BETO pipeline. While the team could not evaluate the yield impact and TEA implications of the genetically improved strains, the BETO portfolio was significantly advanced by the entire REAP team's efforts. TEA modeling included analyses that meet or go beyond other TEAs in BETO's portfolio. The LCA analysis identified critical barriers to PBR design with respect to mixing energy and CO₂ mass transfer. Threshold values for air/CO₂ supply were established, providing critical design standards for scalable PBR systems.
- Statements that PBR systems are too expensive may be premature. Quantifying the economic benefit of the low-crash rates in REAP PBRs should be a goal for future TEA studies. The effect of additional co-products toward achieving BETO cost targets in nth generation PBR systems cannot be assessed at present. The strategic design decision made during proposal preparation to focus on water conservation for arid-region deployment rests on sound reasoning

that has not changed. The REAP vision was ambitious and made within the context of a limited-competition, two-phase project plan. With no phase two funding, it is inevitable that some key REAP assessment parameters will be lacking at the end of stage one.

- The value proposition for extremophile growth in PBR systems for deployment in arid regions to reduce evaporative water loss was firmly established. Cyanidiales strains demonstrated over 35 weight percent biocrude oil yields from high-protein/low-lipid biomass, eliminating the need for lipid induction via nutrient limitation and thus the associated productivity losses. Significant progress toward nutrient recycling was obtained and published.²⁴ The algae crop rotation system was effective in minimizing winter/summer productivity differences, and the

PBR systems operated without any rain or wind associated culture crashes seen so often in open-raceway ponds. This was true for the green and red algal strains in the rotation.

- Direct and sequential HTL systems were compared and benefits for both approaches identified. Sequential HTL offers a potential route to co-product recovery, but direct HTL afforded better results in terms of yield and oil quality in batch processing. With a no-cost extension in place, the PI and HTL team are conferring with UOP engineers regarding the upgrading of biocrude feedstock and solids separation to include metals and additional phosphorus removal, plus associated cost estimates.
- Finally, BETO-REAP funding has resulted in 12 papers published to date in the primary scientific literature with 4 more submitted and under review.

²⁴ T. Selvaratnam, H. Reddy, T. Muppaneni, F. O. Holguin, N. Nirmalakhandan, P. J. Lammers, and S. Deng, "Optimizing Energy Yields from Nutrient Recycling Using Sequential Hydrothermal Liquefaction with *Galdieria Sulphuraria*," *Algal Research* 12 (2015): 74–79, doi:[10.1016/j.algal.2015.07.007](https://doi.org/10.1016/j.algal.2015.07.007).

SCALE-UP OF ALGAL BIOFUEL PRODUCTION USING WASTE NUTRIENTS

(WBS #: 1.3.5.240)

Project Description

Growing algae in wastewater media utilizes waste nutrients and carbon, supporting mixotrophic and heterotrophic growth in addition to autotrophic, leading to high areal productivities and biofuel potential with relatively low greenhouse gas intensity. Experimental studies were conducted at a full-scale wastewater treatment plant (0.6 million gallons per day, 7 acres of raceways) in California. Pilot raceway ponds were also installed at the site to investigate optimization of biomass production, wastewater treatment, and harvesting through the manipulation of pond dilution rates, diel influent timing, and CO₂ addition. Biomass harvested from these systems (33 g/m²/day

Recipient:	California Polytechnic State University
Principal Investigator:	Tryg Lundquist
Project Dates:	10/1/2013–3/31/2016
Project Category:	Sun-setting
Project Type:	FY 2013—Advancements in Algal Biomass Yield (ABY1): DE-FOA-0000811
Total DOE Funding:	\$1,480,883

annual average productivity) was transformed to biocrude through HTL, and yields of biocrude and fuel distillate were measured. Wastewater from HTL was found to be a suitable medium for additional algal growth. Productivity and bioflocculation of cultures was found to correlate to certain community genetic compositions. Finally, laboratory PBR technology was developed that allows rapid estimation of areal raceway productivity of test strains under stimulated climates. TEA and LCA using the CA-GREET model and BETO harmonized inputs resulted

Weighted Project Score: 7.7

Weighting: Approach–25%, Relevance–25%, and Accomplishments and Progress–50%.

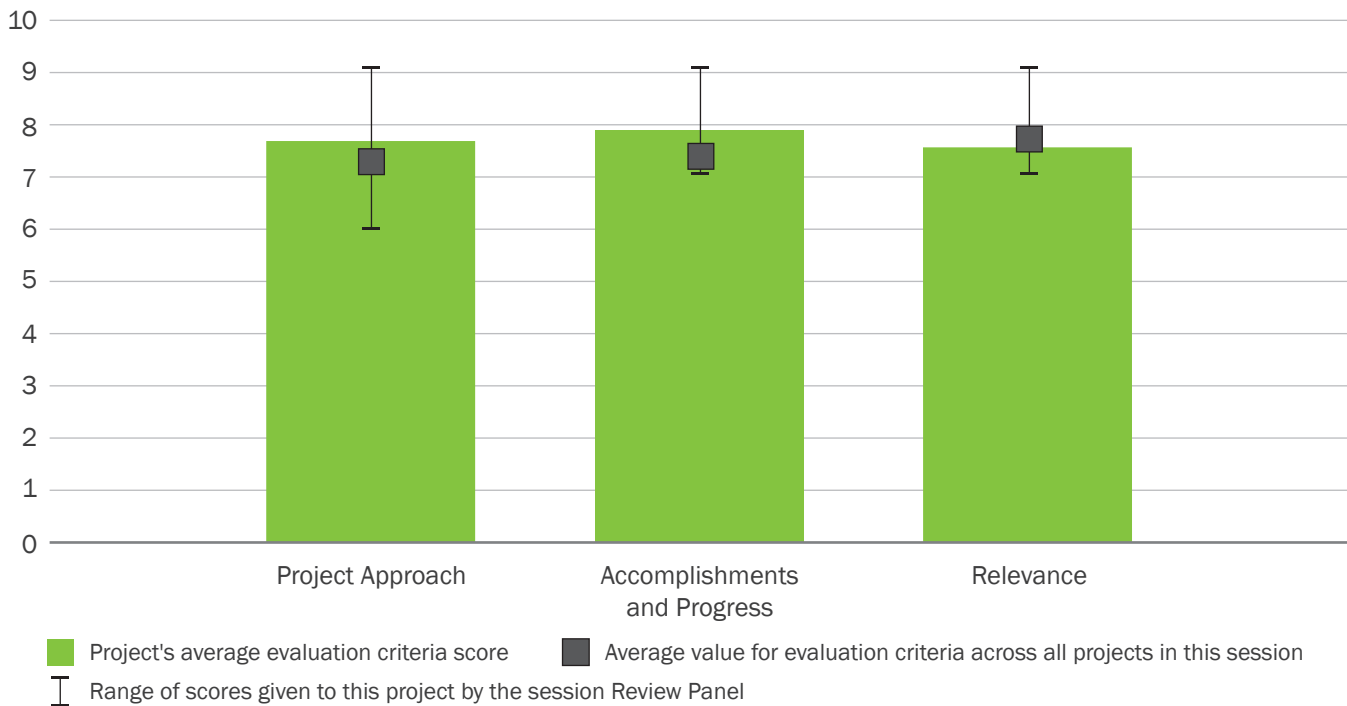

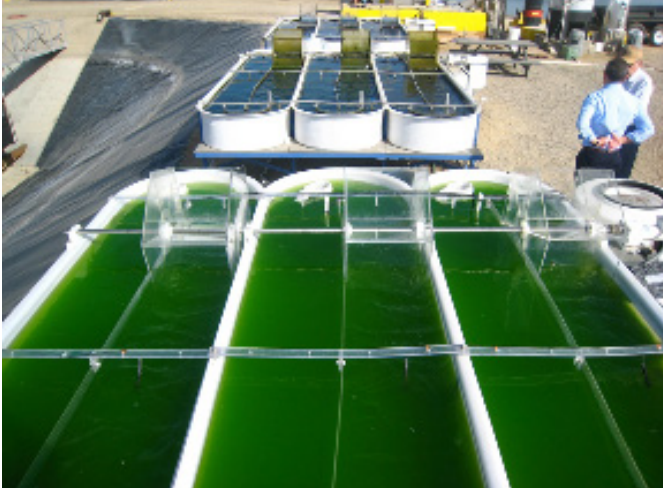

in a MFSP of \$4–\$9/gge (2011\$) depending on revenue streams. Greenhouse gas emissions were estimated to be 13 g of CO₂ equivalent per megajoule biofuel intermediate.

Overall Impressions

- This project did an excellent job of focusing on using wastewater for algal growth and water cleanup. I think the TEA of this project would benefit greatly from including a reputable member of industry practiced in upgrading oils to make them suitable as a refinery feedstock. The industry partner should advise on the cost of upgrading (including the removal of metals) the different oils generated by different HTL operating conditions to make them acceptable to a refiner and at what discount the refiner would want in order to take the oils.
- Algae wastewater systems represent low-hanging fruit that will help to jumpstart the algal biofuels industry. This work has demonstrated excellent productivities and \$/gge that can be achieved with such an approach. The concept of a closed loop with complete recycle of the HTL aqueous stream is encouraging, but will require longer-term studies. It is not clear how identification of high-performance strains and community genetics studies will be used to influence polycultures at scale when using wastewater in outdoor systems.
- Overall sound project that shows the impact of using nutrient from wastewater streams, which could have severe impact on the cost of large-scale cultivation.
- Using wastewater treatment service as main nutrient inputs, demonstrating such high productivities, and meeting or exceeding several MYPP goals and the accompanying TEA/LCA demonstrates the clear feasibility of this method for biomass production.
- Overall, this project should be commended for a multi-faceted approach toward addressing several relevant barriers for BETO, as well as generating data indicating progress toward improved productivity and processing toward the objective of 2,500 gallons per acre per year. Uniquely, this work incorporates wastewater as a source of water and nutrients, differentiating it from many other projects in the BETO portfolio and making it a valuable endeavor.
- The project has accomplished many of its original goals. Work appeared to be fully integrated—from strain selection through outdoor production, harvesting, conversion, and regrowth on recycled nutrient streams. Models of the integrated approach suggested that BETO MYPP goals for productivity and carbon intensity of algal biofuels could be met. Wastewater treatment credits could be used to drive down the cost of fuels to values close to BETO MYPP goals. The project did not evaluate the relative contribution of autotrophic and heterotrophic growth to the system's overall productivity, so it is unclear how much of the growth comes from photosynthetic growth.

PI Response to Reviewer Comments

- Regarding the value of community genetics characterization for scaled-up wastewater polyculture: If organisms are identified that correlate to culture properties (e.g., bioflocculation, productivity), then

perhaps the community composition of the cultures could be influenced to promote desirable characteristics. Such influences might be through inoculation, enrichment, or otherwise changing the operation of the culture reactors. At a minimum, genetic techniques might give algae farmers forewarning of culture changes, allowing early response. This community genetics work is among the first ever conducted on algae polycultures. The modest sub-contract to SNL to improve our understanding of algal-bacterial community dynamics was seen by the PI as a relevant investment. SNL has to develop new methods to analyze and understand the large amounts of data generated from our polyculture sampling. This development process is continuing at SNL beyond the end of the ABY1 project. Additional results and recommendations are expected in the coming months.

An important outcome of Dr. Huesemann's work at PNNL-Sequim was development of the benchtop Laboratory Environmental Algae Pond Simulator (LEAPS) reactors as part of this project. LEAPS is meant to more accurately simulate outdoor pond culture performance than other available technologies. During ABY1, LEAPS performance was tested against 3.5-square meter raceways operating at the Delhi, California, site. *Chlorella sorokinana* (DOE 1412) cultures in LEAPS had similar growth curves as the same strain in the Delhi raceways. During our ABY2 project, this pure culture validation will be

extended to wastewater polycultures using new continuous-flow benchtop reactors, similar to LEAPS. If successful, such benchtop reactors should greatly reduce the cost and increase the rate of R&D related to both mono- and poly-culture raceway cultures. The ultimate promise of this type of research equipment is that culturing methods and strains could be optimized in the lab for any future outdoor scale-up location, saving a larger onsite R&D effort and more quickly reducing uncertainties for scale-up investments.

Data to calculate the contribution of heterotrophic and autotrophic growth to the systems overall productivity has been collected for this project, and this is currently being calculated for inclusion in the final report. In past projects, the amount of heterotrophic biomass (both algal and bacterial) has ranged from one-half of the biomass in the winter to approximately one-third of the biomass in the summer. Therefore, historically depending on season, the photosynthetic biomass is approximately one-half to two-thirds of the total biomass. Preliminary analysis of this project's data seems in line with these conclusions.

PNNL advised and continues to advise on HTL oil upgrading and oil conditions needed for refining for the TEA.

The PI appreciates the reviewers' helpful comments and critiques.

INTEGRATED LOW-COST AND HIGH-YIELD MICROALGA BIOFUEL INTERMEDIATES PRODUCTION

(WBS #: 1.3.5.243)

Project Description

This project will develop improved microalgae strains for higher productivity of biofuels and biofuel intermediates. Microalgae will be cultivated on treated wastewater, providing nutrient removal along with biofuel production. This will allow achievement of DOE’s goal of 3,700 gallons of algae biofuel intermediate per acre per year in an outdoor test environment by 2020, as well as \$3/gge by 2022. The project includes the integration of several innovative processes, including the development of algae strains with improved carbohydrate and lipid productivity; increased biomass productivity through mixotrophic processes; and conversion of the entire biomass to biofuel

Recipient:	MicroBio Engineering
Principal Investigator:	John Benemann
Project Dates:	10/1/2016–9/30/2019
Project Category:	New
Project Type:	FY 2016—Advancements in Algal Biomass Yield Phase 2 (ABY2): DE-FOA-0001471
Total DOE Funding:	\$5,000,000

intermediates utilizing extractions, fermentations, and HTL of residual biomass. Strain selection will be conducted on mutagenized cells through the manipulation of environmental parameters in PBRs operated to enrich for strains with desired traits. Selected strains will be cultivated outdoors in wastewater ponds and biomass harvested by bioflocculation. Challenges to be overcome include the successful selection of enhanced strains and the maintenance of desirable traits in the absence of continued selective pressure, and their applications in mixotrophic cultivation. The initial stage of this recently funded

Weighted Project Score: 7.3

Weighting: Approach–25%, Relevance–25%, and Future Work–50%.

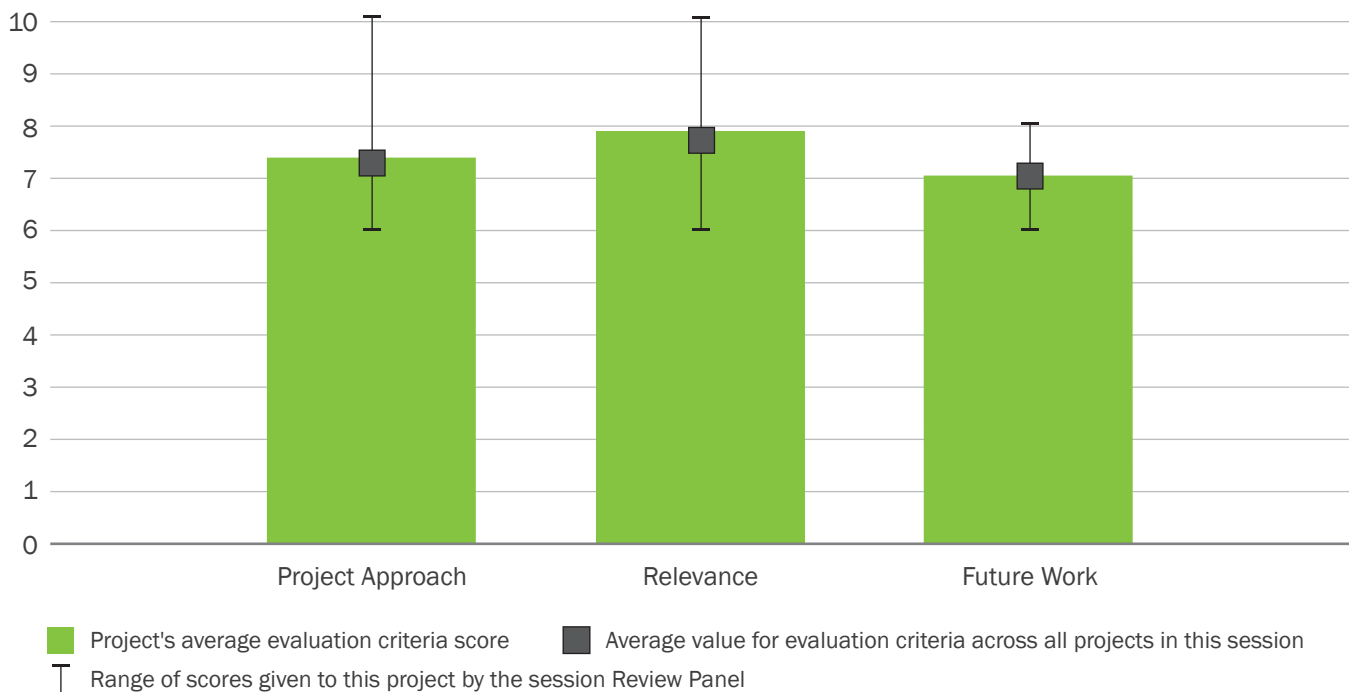



project, currently underway, focuses on the acquisition of baseline data from wild-type strains and the development of PBRs for enrichment cultures.

Overall Impressions

- I think the TEA of this project would benefit greatly from including a reputable member of industry practiced in upgrading oils to make them suitable as a refinery feedstock. The industry partner should advise on the cost of upgrading (including the removal of metals) the different oils generated by different HTL operating conditions to make them acceptable to a refiner and at what discount the refiner would want in order to take the oils.
- This will be a large effort with an excellent team. A variety of approaches will be used to increase overall fuel productivity, including strain improvements, mixotrophy, and downstream-process optimization. However, it was not clear from the presentation what sort of innovation will be implemented that is expected to enable productivity targets to be met. Trying to simultaneously generate strains with high lipid, carbohydrate, or protein would suggest the lack of a clear path to improved economic outcomes, and strains that are enriched for one component may exhibit lower productivity overall.
- Overall, this project shows some innovative ideas in order to best take advantage of wastewater streams. The use of wastewater could potentially reduce the overall operational costs by the reduction of nutrient inputs, though care may need to be taken as high biomass yield can sometimes not be achieved without supplemental nutrients.
- This is a straightforward project addressing strain selection and improvement with clear targets.
- This project aims to improve several aspects of algal biomass production for biofuels, ranging from strain selection through conversion technologies, making it highly relevant for BETO. A strength of the project is the focus on using reclaimed wastewater to cultivate strains, making it stand out from other projects in the portfolio. Overall, this project takes on a lot of varied efforts and will likely lead to significant advances in at least a few technology areas that will demonstrate concrete advances in improving areal productivity of fuels derived from algal biomass.
- This new project seeks to address BETO MYPP goals for productivity (3,700 gallons per acre per year by 2020) and price (\$3/gge by 2022) through optimized growth on wastewater and low-energy downstream processing, though it is unclear how much of the yield target is accomplished from heterotrophic growth versus photosynthetic growth. The team presented a clear plan aligned with original project objectives. The team is encouraged to build off of previous accomplishments during resource allocation for this project.

PI Response to Reviewer Comments

- The central objective of this project is to select algal strains that preferentially produce either carbohydrates or oils, not both, without decrease in productivity. (Wild-type strains can produce high levels of

oils or carbohydrates, but only when nutrient-limited and with reduced productivities). High protein content is typical for wild-type strains; therefore, protein fermentations are included to cover all options, including fermentation of residual biomass (after extraction of oil or fermentation of carbohydrates).

The reclaimed (secondary treated) wastewaters used in the pond cultivation studies have all the required nutrients for maximum growth, as already demon-

strated by prior work by the Cal Poly-MicroBio Engineering team.

In response to the question on how much of the yield target is accomplished from heterotrophic growth versus photosynthetic growth, the objective of the mixotrophic growth is to minimize actual heterotrophic growth, at least by the non-algal actors.

The PNNL team is highly qualified and suffices to cover upgrading oils to make them suitable as a refinery feedstock.

ADVANCING COMMERCIALIZATION OF ALGAL BIOFUELS THROUGH INCREASED BIOMASS PRODUCTIVITY AND TECHNICAL INTEGRATION

(WBS #: 1.3.5.249)

Project Description

Using top-performing algal *Nannochloropsis* sp. strains, sustained improvements in biomass productivity and lipid yield were explored throughout the different unit operations at Cellana. The goal was to integrate approaches representing the “best of the best” results achieved in three primary areas: strain improvement, cultivation, and downstream dewatering. Improvements leveraged from work across all sites in this team yielded algal biomass with a lipid content of more than 40% and culture productivity of 14 g/m²/day, sufficient to enable yields consistent

Recipient:	Cellana LLC
Principal Investigator:	David Anton
Project Dates:	7/18/2014–1/30/2015
Project Category:	Sun-setting
Project Type:	FY 2013—Advancements in Algal Biomass Yield (ABY1): DE-FOA-0000811
Total DOE Funding:	\$3,500,000

with BETO’s advanced biofuel intermediate goal of 2,500 gallons per acre per year by 2018. In addition, this project demonstrated the use of recycled flue gas as a CO₂ source without compromise in productivity. Improved energy efficiency was achieved through process changes in the dewatering step, and supercritical CO₂ extraction proved to capture more than 80% of the high-value Omega 3’s from the neutral lipid fraction. Challenges included replication of indoor cultivation results at one site to outdoor production at another, as well as translation of productivity and compositional results from the 1,000 L outdoor scale

Weighted Project Score: 7.4

Weighting: Approach–25%, Relevance–25%, and Accomplishments and Progress–50%.

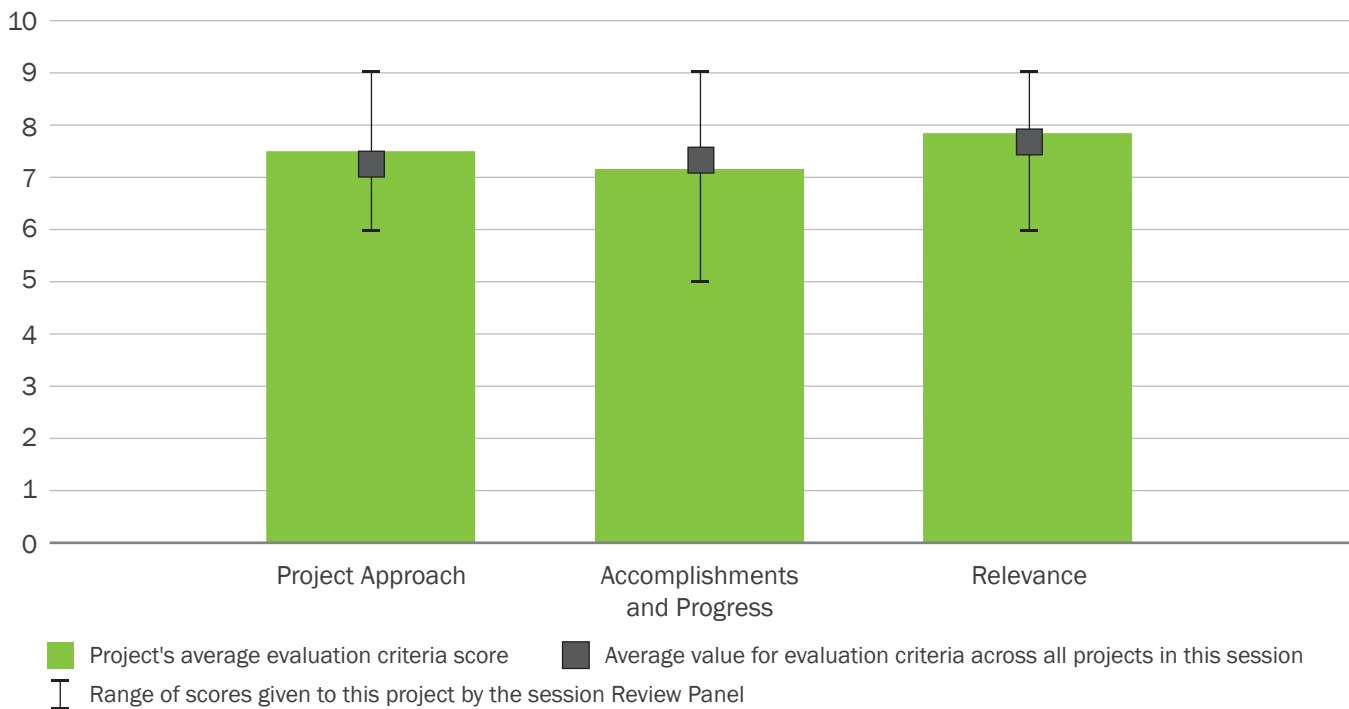



to the 60,000 L scale. Project results confirm the techno-economics to support commercial-scale production of algae-based energy products and nutritional co-products, representing a highly sustainable source for oils, proteins, and Omega-3s that can be produced in the United States.

Overall Impressions

- Great project. The trajectory is promising to increase productivity further. I appreciate the full integration and extended testing. Additional work on scaling up further would be necessary to understand if the results can be replicated at larger facilities.
- It appears that productivity improvements have been made that enable the MYPP targets; however, enough detail is lacking that it is difficult to make a thorough evaluation. Details and lessons learned from this project should continue to be disseminated through peer reviewed publications.
- This project shows significant accomplishments that show the viability of using strains that have commercial value in the high-value product space that may also have an impact on the need for algal biomass for fuel production.
- Achieving sustainable high productivity is still a challenge, but addressing it by batch production may be part of the answer.

- The project reported incremental progress toward specific focus areas, including meeting project goals in all three priority areas. None of the technical accomplishments stand out as particularly important. This project considered the applications of the expected outputs, and worked to scale up, making it more relevant.
- The project appeared to meet many stated technical targets, including strain improvements, productivity improvements, dewatering energy use, and conversion yields. The project goals and accomplishments are clearly in line with BETO MYPP goals for areal production (2,500 gallons per acre per year by 2018). The project has clear relevance to the algal biofuels industry and involved entities with commercial ambitions tied directly to project results.

PI Response to Reviewer Comments

- The team thanks the Review Panel for its comments and looks forward to future continued and expanded collaboration opportunities to sustain and advance progress toward the MYPP goals, which, in turn, will move the algae industry forward. Sustained DOE support and its recognition of the need for multi-product business models to drive initial economic viability in the commercial development of algal biofuels has been critical to success in this field to date. Further proof of concept at industrially and commercially relevant demonstration scales is required to ensure that additional improvements necessary to this emerging and expanding area are realized. Given the expense and associated timing with work at larger scale, the substantial involvement of DOE, the near real-time feedback from DOE program officers, and their close coordination and oversight of BETO projects truly enable differential flexibility and response to results generated in these projects. Our team is truly grateful for BETO's ongoing support of work on algal biofuel development.

DEVELOPMENT OF ALGAL BIOMASS YIELD IMPROVEMENTS IN AN INTEGRATED PROCESS – PHASE I

(WBS #: 1.3.5.250)

Project Description

GAI collaborated with the Scripps Institution of Oceanography at the University of California, San Diego; TSD Management; GE Power & Water; Kuehnle AgroSystems; and other organizations to increase algae oil yield and optimize unit operations to create a clear path for successful commercial development of algal-derived, drop-in fuels. The project goals include (1) developing improved strains and cultivation methods for a 40% increase in algal biofuel intermediate yield, (2) developing new harvest and dewatering technology for an 88% reduction in downstream-processing energy, and (3) achieving these

Recipient:	Global Algae Innovations Inc. (GAI)
Principal Investigator:	David Hazlebeck
Project Dates:	10/1/2013–9/30/2016
Project Category:	Sun-setting
Project Type:	FY 2013—Advancements in Algal Biomass Yield (ABY1): DE-FOA-0000811
Total DOE Funding:	\$4,996,784

improvements in an integrated outdoor system that reduces the projected algae biomass production cost by 58%.

All project objectives were exceeded, two major breakthroughs were achieved, and the project was completed on schedule and within budget. The first breakthrough is an improved cultivation system approach that increases algal productivity by 80% in growth phase while simultaneously reducing the energy use for cultivation by 67%. The second is a harvesting and dewatering technology that reduces energy use by 95%–99%, achieves 100%

Weighted Project Score: 9.0

Weighting: Approach–25%, Relevance–25%, and Accomplishments and Progress–50%.

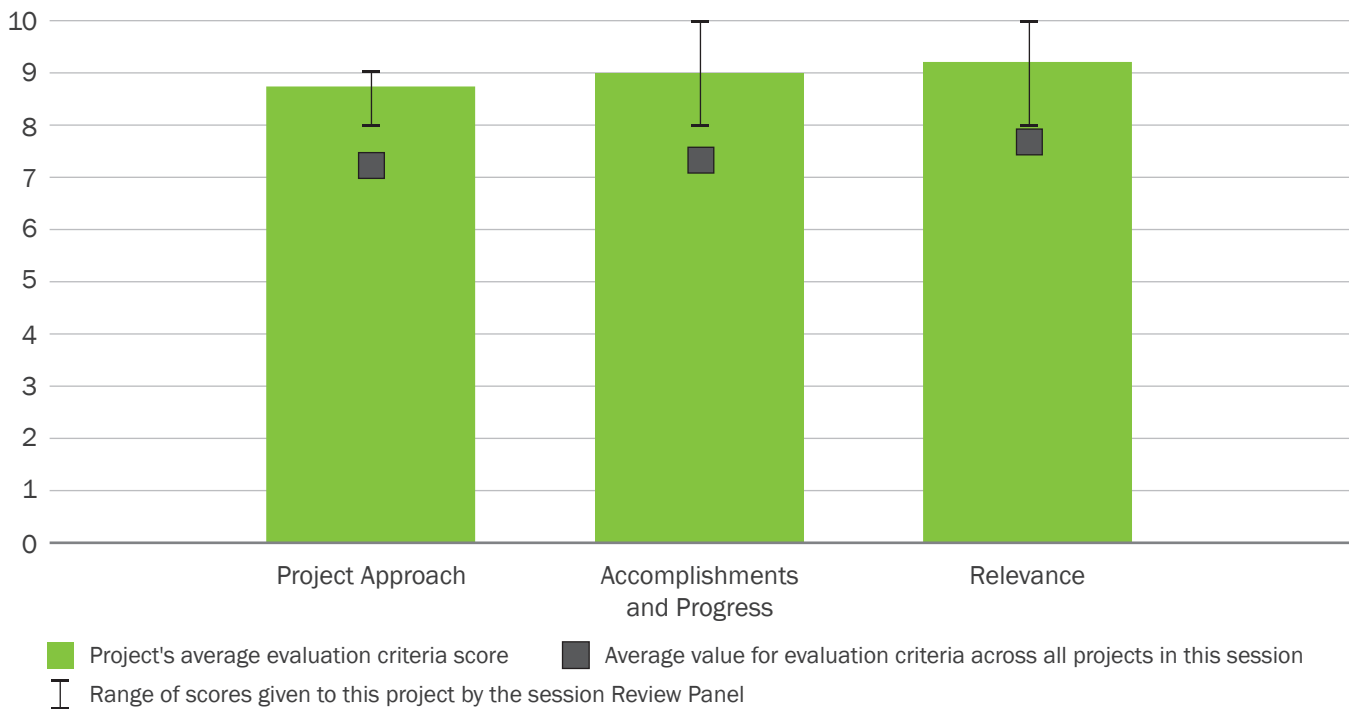

harvest efficiency with crystal clear permeate, and produces a 15%–20% algae slurry. This technology is now available to the algae industry commercially as the Zobi Harvester[®]. These revolutionary technologies enabled the project to exceed the BETO MYPP 2020 target of 3,700 gallons per acre per year and exceed the 2022 targets for energy use and production cost.

Overall Impressions

- Excellent project. Well thought out and demonstrated at a meaningful scale. The approaches are innovative and transformative and have achieved future goals of the MYPP. The dewatering system development is relevant to the industry as units have already been sold. It will be useful to find out the performance of the dewatering system once it has been in operation at other, more extreme environments (higher loading of contaminants and agricultural residue) and how well the productivity gains translate to other environments.
- GAI has presented a very strong package of improvements throughout an integrated and proven process. Lack of detail requires us to take some aspects on faith.

- Overall, this project exhibited a solid technical approach in achieving stated goals and deliverables. Innovative ideas for productivity improvement through improved process improvement.
- This project accomplished its goals in a fully integrated industrial environment. Accomplishments in productivity improvement and low-cost dewatering are particularly notable. Productivity enhancements were made primarily through improvements in cultivation strategies and operations rather than strain improvements. Project results are highly relevant to industry, as well as BETO's MYPP goals.

PI Response to Reviewer Comments

- The revolutionary improvements in cultivation and harvesting achieved in this project have brought economical algae biofuel production within reach. Support for longer-term operations at scales of 1 acre or more to solidify process consistency and product quality could lead to a commercially viable algae commodities industry. An algae industry operating with the high agricultural productivity demonstrated in this project, which is 50-fold over terrestrial crops, would be transformational in terms of creating high-quality, rural jobs and increasing our standard of living.

PRODUCTION OF BIOCRUDE IN AN ADVANCED PHOTOBIOREACTOR-BASED BIOREFINERY

(WBS #: 1.3.5.260)

Project Description

Algenol Biotech, NREL, Georgia Institute of Technology, and Reliance Industries Limited have formed a team to advance the state of the art in algal production and downstream processing with the end goal of a sustainable, economically viable biofuel intermediate product. The project includes examining the production of high-value co-products as a market entry strategy and to enhance the economics of a biorefinery for biocrude production. The project targets innovations in biology, operations, and engineering. It builds on the experience gained at Algenol in its DOE-funded project for an integrated biorefinery for ethanol production. The goals of the project are to achieve

Recipient:	Algenol
Principal Investigator:	Ronald Chance
Project Dates:	10/1/2016–9/30/2019
Project Category:	New
Project Type:	FY 2016—Advancements in Algal Biomass Yield Phase 2 (ABY2): DE-FOA-0001471
Total DOE Funding:	\$5,000,000

a biofuel intermediate productivity of greater than 4,000 gallons per acre per year on an annualized basis; pilot energy efficient innovations in biomass harvesting, dewatering, and HTL to deliver an energy expenditure less than 10% of the energy content in biofuel intermediate and an overall greater than 60% carbon footprint reduction compared to fossil sources; and deliver a comprehensive TEA that identifies limiting factors for commercial viability for a PBR-based biofuel product.

Weighted Project Score: 8.0

Weighting: Approach–25%, Relevance–25%, and Future Work–50%.

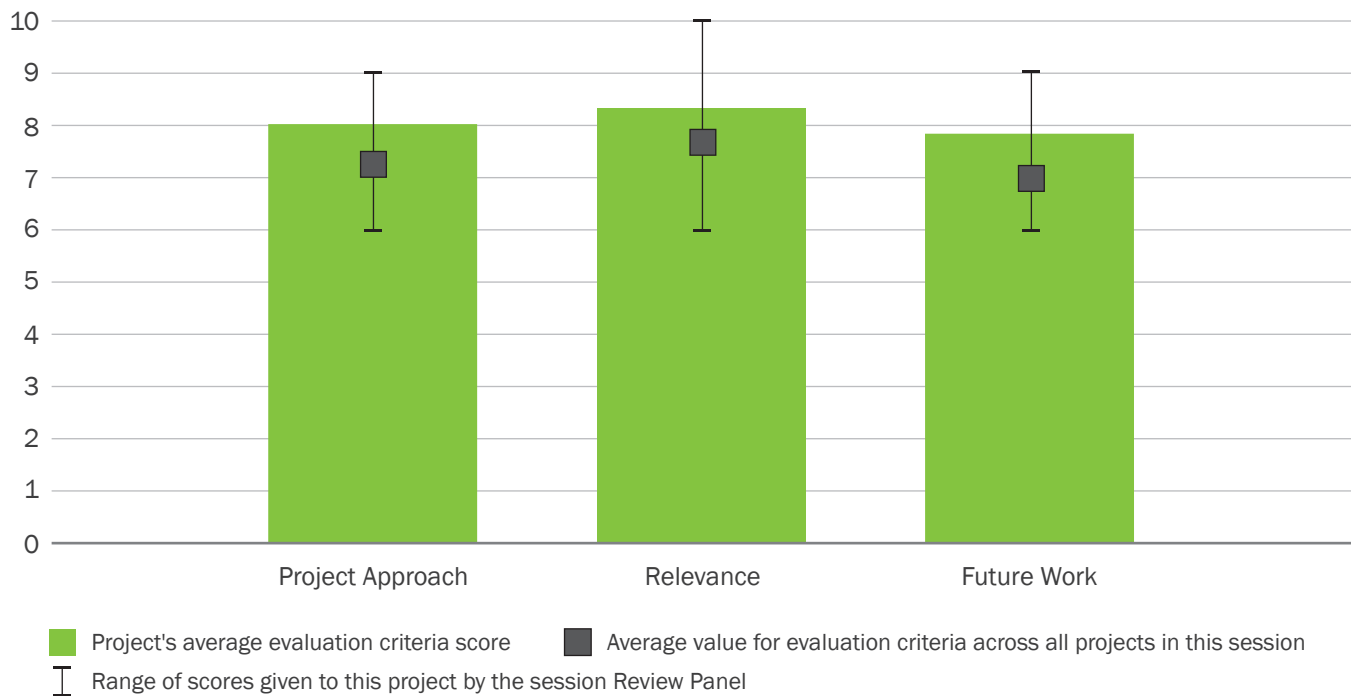



Overall Impressions

- This is a very strong project that should provide reliable information on costs and productivity for some unique algal strains. The presentation contained good and relevant details for their intended technical approach. This project has the potential to set the SOT for PBR in terms of both economics and lower-cost biomass production.
- This team is well poised to explore the potential for PBR-based biofuel production through a combination of strain and process improvements. Few details are provided, but opportunities throughout the pathway are being considered. A systematic TEA comparison with open ponds will be of particular value. The chosen co-product strategy is excellent and may enable fairly rapid commercialization.
- Overall, this project is well laid out and clearly has objectives that meet the current program's goals and deliverables. Generally, large-scale PBRs for fuel production are not able to scale up due to large capital and operational expenses. Due diligence should be performed in analyzing capital and operational cost when compared to large-scale open-pond systems. Phycocyanin market analysis should be done in order to better understand the market pricing, as well as the potential impact of new input streams.
- It is important to include PBR production of biomass in the overall evaluation of potential biomass production from algae, and having a detailed com-

parison between PBRs and open-pond cultivation will give direction to development and improvement of PBR systems.

- The plan forward is polished and organized; however, it is somewhat short on detail regarding specific strategies, making this project somewhat opaque. An advantage of this project is the aim and ability to improve multiple aspects of fuel production from algae in a highly integrated way. It's anticipated that this effort will lead to advances in technology that will directly benefit industry and lead toward more cost-effective production of algal biomass for biofuels.
- This new project presented a clear work plan aligned with original project objectives and, if successful, could meet a number of BETO MYPP goals. The project has clear relevance to the bioenergy industry, uses co-products to drive down the cost of fuels, and involves team members that could pull the technology through to commercialization if the project meets its stated goals.

PI Response to Reviewer Comments

- As discussed above, Algenol believes that PBR-based technology can compete favorably with open-pond production systems when viewed from a broad and comprehensive perspective. As part of the planned program, a comparison of growth of Algenol's proprietary cyanobacterial strain in ponds versus PBRs will be made, and the results will help to further refine our existing, highly detailed techno-economic model. We have already shared our TEA analysis with NREL in a PBR-pond comparison exercise separate from the project under discussion. Their independent work showed PBRs and open ponds to be much closer in costs than previously thought, mainly due to the advancements we have made in PBR manufacturing combined with the productivity enhancement that PBR operation enables.

In support of the selection of phycocyanin as the leading co-product candidate, we have performed a detailed assessment of the existing phycocyanin market along with anticipated future growth trends. This analysis has supported our conclusion that phycocyanin represents an excellent co-product opportunity, which was further validated through discussions with several potential customers and partners, who have provided detailed guidance on phycocyanin pricing and quality requirements.

PRODUCING ALGAE FOR CO-PRODUCTS AND ENERGY (PACE)

(WBS #: 1.3.5.300)

Project Description

Building off the most advanced algal biofuels systems designed to date, PACE is developing and integrating emerging and leading-edge technologies to (1) produce algal biofuel at less than \$5/gge; (2) achieve an energy return on investment greater than 8; (3) achieve a carbon index less than 40 g CO₂ per millijoule; and (4) recover and recycle more than 80% nutrients and CO₂ while reducing water use by 50%. These objectives will be achieved by (1) improving sustainable biomass yield greater than two-fold; (2) producing co-products to offset fuel costs by 30%–50%; and (3) optimizing integrated processes through LCA/TEA studies. PACE uniquely addresses each of BETO’s MYPP objectives for algal biofuels.

Recipient:	Colorado School of Mines
Principal Investigator:	Richard Sayre
Project Dates:	10/1/2015–3/31/2019
Project Category:	Ongoing
Project Type:	FY 2015—Targeted Algae Biofuels and Bioproducts (TABB): DE-FOA-0001162
Total DOE Funding:	\$9,000,000

Major challenges include (1) developing robust genetic transformation and genome editing tools for *C. sorokiniana*, (2) producing and recovering valuable co-products from biocrude, and (3) developing energy efficient algal harvesting systems that are scalable. To date, PACE has developed robust genetic engineering and genome editing protocols for *C. sorokiniana*; demonstrated cultivation of algae in 80% seawater at normal growth rates; achieved substantial progress on improving acoustic harvester efficiency; chemically converted algal carbohydrates to fuel

Weighted Project Score: 8.1

Weighting: For ongoing projects, there is equal weighting across all four evaluation criteria: Approach, Relevance, Accomplishments and Progress, and Future Work.

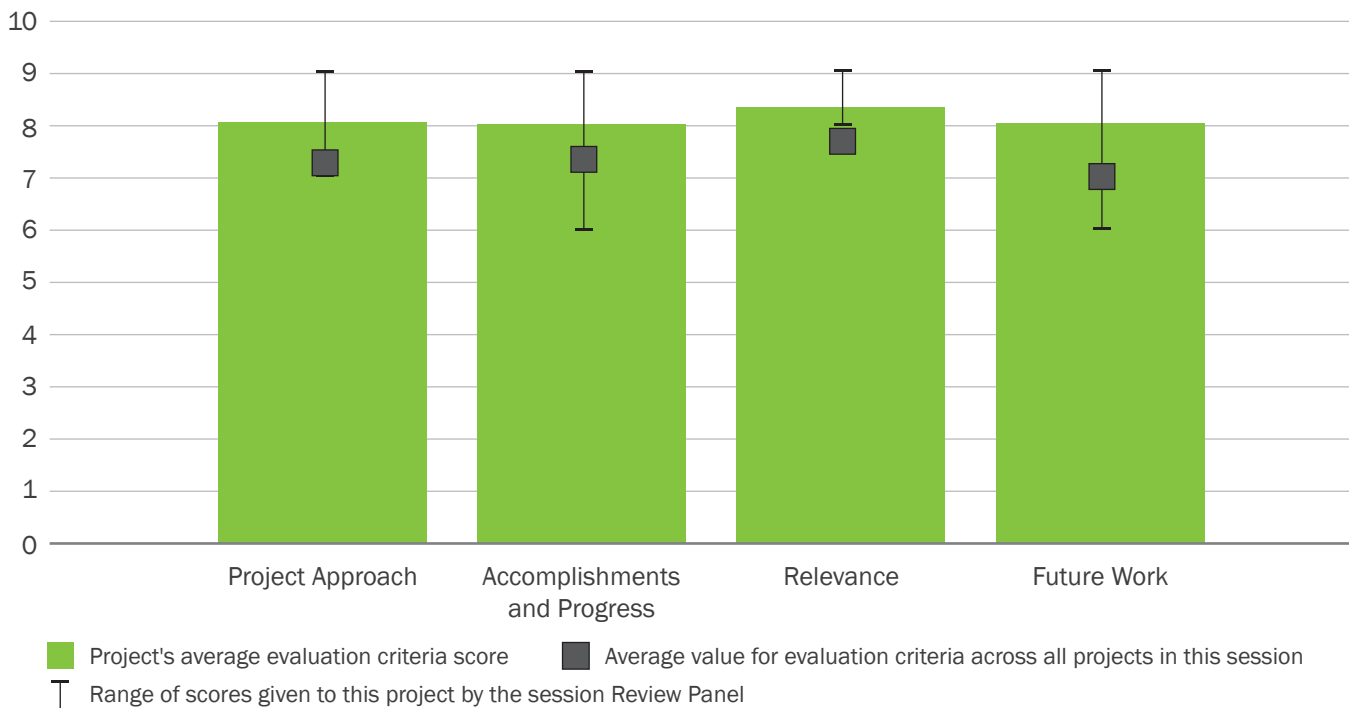

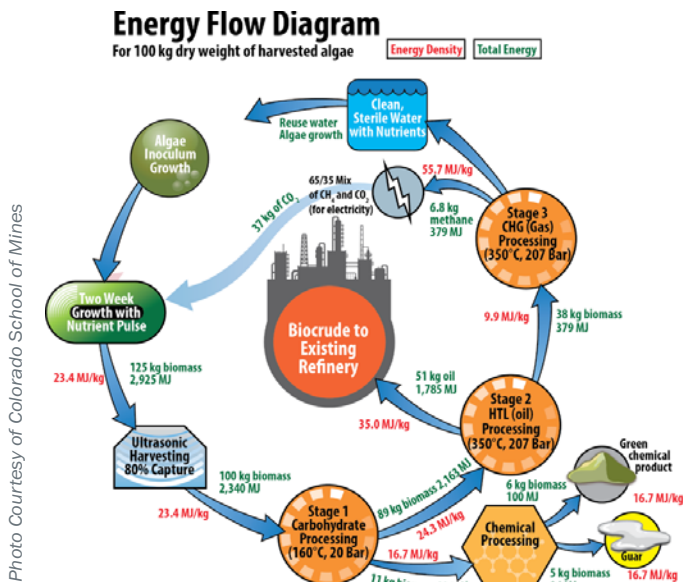

and co-products; developed a continuous flow, two-stage HTL process to separate carbohydrates from the oil fraction—partner Reliance Industries has established the first fully integrated algal biofuels system at Gagwa, India; and carried out extensive LCA/TEA modeling to identify process bottle necks and constraints.

Overall Impressions

- This project team is a collection of leaders in their fields brought together to address the project's technical tasks. I suggest the project consider how a commercial facility producing these products (or any types of products) impacts the market price and how this would impact their cost evaluation. I think the TEA of this project would benefit greatly from including a reputable member of industry practiced in upgrading oils to make them suitable as a refinery feedstock. The industry partner should advise on the cost of upgrading (including the removal of metals) the different oils generated by different HTL operating conditions to make them acceptable to a refiner and at what discount the refiner would want in order to take the oils.
- This is a massive project exploring many promising strain and process enhancements. The specific approaches appear, in general, to be well considered. The choice of co-products is questionable, particularly the PEA product, which has a tiny market. Integration of all project improvements will be challenging, particularly in the stacking of multiple traits of interest. It will be critical for the investigators to be flexible as the project evolves and not be locked into a particular technology path.
- Overall, this project shows significant promise in the ability to provide data and improvements essential to meeting the program's goals and deliverables.
- The project demonstrates several key improvements in crop stability and crop protection via genetic engineering, and the suicide gene system development will be critical as well. There are a lot of tasks in this project (full process from cultivation to extraction/co-product production), and it seems well executed so far.
- This large consortium is clearly organized into three main project areas that are aimed at reducing the overall cost of producing biofuel from algae. Within these three main areas, there is a diversity of more specifically focused projects leveraging expertise and infrastructure developed from previously funded efforts, making this a valuable continued investment.
- The project is clearly aligned with BETO MYPP goals for genetic advances, increasing productivity, and using co-products to enable competitively priced fuels. If successful, the project should have broad impact on the algal biofuels industry by demonstrating utilization of the genetics toolbox to improve system economics for fuels and co-products. Timelines related to production of the improved organism at a reasonable scale for downstream processing work may present a challenge, but the project team is aware of these challenges and will work to mitigate them to the extent that they are able.

PI Response to Reviewer Comments

- We thank the reviewers again for their comments. We have a very reputable full-scale algal production, harvesting, fuel conversion, and refinery operations partner in Reliance Industries Limited. An additional relevant partner is Genefuel Corporation, with experience in commercial-scale HTL. Additional academic input comes from the energy conversion group at Colorado State University. These and other partners' inputs are integral to the TEA development planned for Budget Period 3. By continuously integrating LCA/TEA analyses throughout the project to meet milestones and deliverables, we are confident that we can address challenges to fully integrate operations.

MARINE ALGAE INDUSTRIALIZATION CONSORTIUM (MAGIC): COMBINING BIOFUELS AND HIGH-VALUE BIOPRODUCTS TO MEET RFS

(WBS #: 1.3.5.310)

Project Description

Not provided by project team.

Overall Impressions

- This project team is composed of many experienced individuals and companies. However, it seems this project is disjointed and in many separate areas that may make this project difficult to manage and execute. It also appears that the technical plans are not clear and potentially in flux. This project has been struggling with funding. Minimal information

Recipient:	Duke University
Principal Investigator:	Zackary Johnson
Project Dates:	10/1/2015–8/31/2019
Project Category:	Ongoing
Project Type:	FY 2015—Targeted Algae Biofuels and Bioproducts (TABB): DE-FOA-0001162
Total DOE Funding:	\$5,240,313

was given on the future work details, and I am concerned about the trajectory of this project.

- The presentation for this project was devoid of any substantive information, making it impossible to make a fair evaluation. The project’s underlying approach and work plan may be excellent, but the reviewers were unable to score it well based on what was presented. The relevance to BETO’s goals appears to be on target based on the focus on marine species and adding value through co-products.

Weighted Project Score: 3.8

Weighting: For ongoing projects, there is equal weighting across all four evaluation criteria: Approach, Relevance, Accomplishments and Progress, and Future Work.

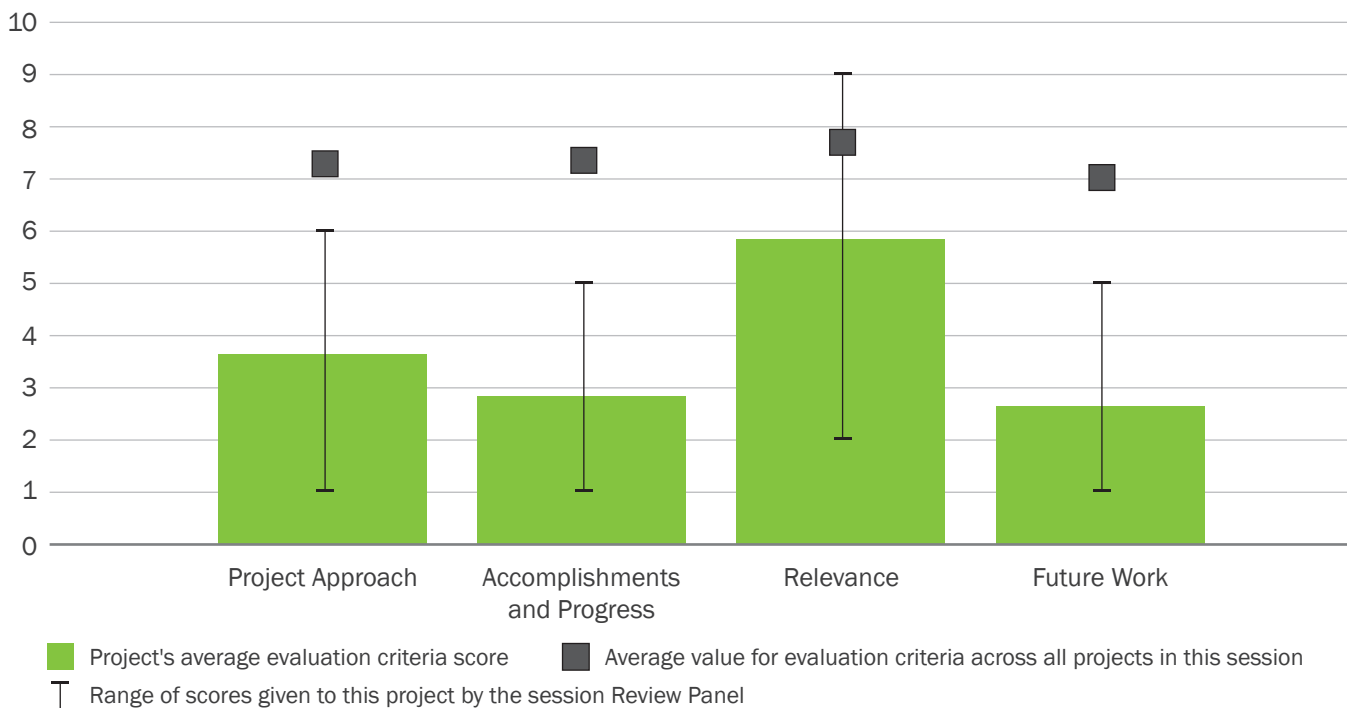

- Overall, this project seems to have potential, but current issues with starting certain aspects of the project, as well as stated goals seeming to be off of the proposed goals, may create irrelevant data or information.
- Not enough details were given to properly evaluate this project. No work was presented, and no details of the work plan were presented.
- Unfortunately, neither the approach nor future work of this project was presented during the Project Peer Review, making it impossible to evaluate these aspects of the work. The only technical accomplishments reported were a list of publications, and it could not be determined which (if any) of these publications directly resulted from work conducted as a part of this project. The overall impression that was given was that the actual project was not well represented by the presentation given.
- The presentation for this project was not responsive to most review requirements. For this reason, it is difficult to determine the relevance of the project to BETO goals or whether the work plan (not discussed) is appropriate for project goals (also not covered).

PI Response to Reviewer Comments

- The MAGIC team thanks the reviewers and DOE for their time and comments on the presentation. Within the minimum space allotted, we have provided additional details that we hope will help with the evaluation process.

It is important to note that this peer review of our project was effectively conducted prior to the full group receiving funding, and so the progress made to date only represents a small fraction of what we expect in the future. Nevertheless, the progress documented in this response, as well as the Project Peer Review presentation, represents work toward this project's goal and does not come from past projects. As documented with previous evaluation criteria, with the successful completion of the validation process and the recent (days before the Project Peer Review meeting) release of funds, the work on this project has just started. The original proposal; validation process, including modified statement of project objectives with revised milestones and decision points (go/no-go); and this peer review all provide us with the solid framework for completing this future work.

We welcome the opportunity to answer any other questions or provide additional clarification.



CONVERSION R&D



PROGRAM AREA



INTRODUCTION

The Bioenergy Technologies Office's (BETO's or the Office's) Conversion Research and Development (R&D) Program focuses on deconstructing feedstock into intermediate streams (sugars, intermediate chemical building blocks, bio-oils, and gaseous mixtures), followed by upgrading these intermediates into fuels and chemicals. Historically, R&D in this area has been divided between thermochemical and biological conversion. BETO recognizes, however, that these divisions are no longer as clear-cut as they once were and that many promising pathways to achieving the Conversion R&D Program's goals require a hybrid approach. The full integration of

these two areas has taken place since the 2015 Project Peer Review.

While Conversion R&D is now managed as a single program, the large number of projects this area funds could not be reviewed in a single session over the course of a week. Because of time constraints, projects were grouped into the following three sessions: Thermochemical Conversion, Biochemical Conversion, and Waste to Energy. To the extent possible, projects were grouped with those utilizing similar technologies, though BETO recognizes that many projects contain elements that could fit into multiple sessions. Each project was only reviewed in one session.

CONVERSION R&D OVERVIEW

Conversion R&D Support of Office Strategic Goals

Conversion R&D's strategic goal is to develop commercially viable technologies for converting biomass feedstocks (via biological and chemical routes) into energy-dense, fungible, finished liquid transportation fuels, bioproducts or chemical intermediates, and bio-power. To achieve this goal, BETO and its partners are exploring a variety of conversion technologies that can be combined into pathways from feedstock to product.

Conversion R&D Support of Office Performance Goals

Conversion R&D's overall performance goal is to develop technologies that reduce the estimated mature technology processing cost of converting algae or lignocellulosic biomass into hydrocarbon fuels, while maximizing the renewable carbon in the desired products. There are many different combinations of unit opera-

tions that could result in a successful conversion strategy. To track the maturity of these processes and evaluate the R&D hurdles for each, several design cases (with cost targets and technical goals) outline how Conversion R&D might achieve its performance goals via continued R&D over the near, medium, and long term. To benchmark the progress of a few representative pathways that link conversion technologies, the Office funds R&D to overcome barriers to support the following cost goals:

- By 2017, validate an nth-plant modeled minimum fuel selling price of \$3/gasoline gallon equivalent (\$2014) via a conversion pathway to hydrocarbon biofuel with a greenhouse gas emissions reduction of 50% or more compared to petroleum-derived fuel.
- By 2022, validate an nth-plant modeled minimum fuel selling price of \$3/gasoline gallon equivalent (\$2014) for two additional conversion pathways to hydrocarbon biofuel with a greenhouse gas emission reduction of 50% or more compared to petroleum-derived fuel.

Conversion R&D Approach for Overcoming Challenges

Conversion R&D has identified the following challenges and barriers across the supply chain as key hurdles to achieving the goals outlined above. Some challenges are shared across other platforms.

- ***Deconstruction and Fractionation Challenges***

- Feedstock variability
- Reactor feed introduction
- Efficient preprocessing
- Efficient pretreatment
- Efficient low-temperature deconstruction
- Efficient high-temperature deconstruction to intermediates

- ***Separations, Cleanup, and Conditioning Challenges***

- Efficient intermediate cleanup and conditioning

- ***Synthesis and Upgrading Challenges***

- Efficient catalytic upgrading of sugars/aromatics, gaseous and bio-oil intermediates to fuels and chemicals

- Product finishing acceptability and performance

- ***Integration and Intensification Challenges***

- Process integration
- Petroleum refinery integration of intermediates
- Aqueous-phase utilization and wastewater treatment

- ***Crosscutting Challenges***

- Cost-effective hydrogen production and utilization
- Materials compatibility and reactor design and optimization

To address these challenges, Conversion R&D organizes activities into six broad groupings: Analysis and Sustainability, Deconstruction and Fractionation, Synthesis of Intermediates and Upgrading, Integration and Intensification, Enabling Technologies, and Oversight and Support. Technical challenges in each of these areas are identified through technology road mapping, techno-economic analyses, stakeholder meetings, industry lessons learned from demonstration and market transformation activities, and active project management of historical and existing projects.





THERMOCHEMICAL CONVERSION R&D

TECHNOLOGY AREA

CONTENTS

INTRODUCTION	229
THERMOCHEMICAL CONVERSION R&D OVERVIEW	229
THERMOCHEMICAL CONVERSION R&D REVIEW PANEL	230
TECHNOLOGY AREA SCORE RESULTS.....	231
THERMOCHEMICAL CONVERSION R&D REVIEW PANEL SUMMARY REPORT.....	232
THERMOCHEMICAL CONVERSION R&D PROGRAMMATIC RESPONSE	238
ANALYSIS AND SUSTAINABILITY INTERFACE	241
THERMOCHEMICAL CONVERSION PLATFORM ANALYSIS.....	243
LIQUEFACTION OF AGRICULTURAL AND FOREST BIOMASS TO “DROP-IN” HYDROCARBON BIOFUELS.....	246
THF CO-SOLVENT BIOMASS FRACTIONATION TO CATALYTIC FUEL PRECURSORS WITH HIGH YIELDS.....	248
CATALYTIC UPGRADING OF BIOCHEMICAL INTERMEDIATES	250
ONE-STEP HIGH-YIELD PRODUCTION OF FUNGIBLE GASOLINE, DIESEL, AND JET FUEL BLENDSTOCKS FROM ETHANOL WITHOUT ADDED HYDROGEN.....	253
CATALYTIC PROCESSES FOR PRODUCTION OF α , ω -DIOLS FROM LIGNOCELLULOSIC BIOMASS.....	256
FAST PYROLYSIS AND UPGRADING	259
LIQUID FUELS VIA UPGRADING OF INDIRECT LIQUEFACTION INTERMEDIATES.....	261
ELECTROCHEMICAL METHODS FOR UPGRADING PYROLYSIS OILS	264
RECOVERING AND UPGRADING BIOGENIC CARBON IN BIOMASS-DERIVED AQUEOUS STREAMS	266
CATALYTIC FAST PYROLYSIS (CFP).....	269
A HYBRID CATALYTIC ROUTE TO FUELS FROM BIOMASS SYNGAS.....	272
CATALYTIC UPGRADING OF THERMOCHEMICAL INTERMEDIATES TO HYDROCARBONS: CONVERSION OF LIGNOCELLULOSIC FEEDSTOCKS.....	275
CATALYTIC CONVERSION OF CELLULOSIC OR ALGAL BIOMASS PLUS METHANE TO DROP-IN HYDROCARBON FUELS AND CHEMICALS.....	277
INTEGRATION AND SCALE-UP + THERMOCHEMICAL (TC) CAPITAL EQUIPMENT	279
CATALYTIC UPGRADING OF THERMOCHEMICAL INTERMEDIATES TO HYDROCARBONS – RESEARCH TRIANGLE INSTITUTE.....	282
BIOMASS-DERIVED PYROLYSIS OIL CORROSION STUDIES	285
BRAZIL BILATERAL—NREL PETROBRAS CRADA.....	287
CONSORTIUM FOR COMPUTATIONAL PHYSICS AND CHEMISTRY	291
DEVELOPMENT AND STANDARDIZATION FOR BIO-OIL CHARACTERIZATION TECHNIQUES	294
CATALYST COST MODEL DEVELOPMENT	297
ADVANCED CATALYST SYNTHESIS AND CHARACTERIZATION	300
FRACTIONATION AND CATALYTIC UPGRADING OF BIO-OIL	303
NOVEL ELECTRO-DEOXYGENATION PROCESS FOR BIO-OIL UPGRADING.....	305

IMPROVED HYDROGEN UTILIZATION AND CARBON RECOVERY FOR HIGHER-EFFICIENCY THERMOCHEMICAL BIO-OIL PATHWAYS.....	308
ADVANCED MEMBRANE SEPARATIONS TO IMPROVE EFFICIENCY OF THERMOCHEMICAL CONVERSION.....	311
FRACTIONAL MULTISTAGE HYDROTHERMAL LIQUEFACTION OF BIOMASS AND CATALYTIC CONVERSION INTO HYDROCARBONS.....	313
RENEWABLE HYDROGEN PRODUCTION FROM BIOMASS PYROLYSIS AQUEOUS PHASE.....	315
BUILDING BLOCKS FROM BIOCRUDE: HIGH VALUE METHOXYPHENOLS.....	317
MELT-STABLE ENGINEERED LIGNIN THERMOPLASTIC: A PRINTABLE RESIN	320
CHEMCATBIO OVERVIEW	323
BIOMASS GASIFICATION FOR CHEMICALS PRODUCTION USING CHEMICAL LOOPING TECHNIQUES.....	326

INTRODUCTION

In the Thermochemical Conversion Research and Development (R&D) session, five external experts from industry reviewed a total of 33 presentations (representing more than 33 projects, as a few presentations were collaborations of different projects across multiple national laboratories).

This review addressed a total U.S. Department of Energy (DOE) investment value of approximately \$144,621,875, which represents approximately 20% of the Bioenergy Technologies Office (BETO or the Office) portfolio reviewed during the 2017 Project Peer Review. During the Project Peer Review meeting, the principal investigator (PI) for each project was given 15 to 60 minutes (depending on the project's funding level and relative importance to achieving BETO goals) to

deliver a presentation and respond to questions from the Review Panel.

The Review Panel evaluated and scored projects for their project approach, technical progress and accomplishments, relevance to BETO goals, and future plans. This section of the report contains the results of the project reviews, including full scoring information for each project, summary comments from each reviewer, and any public response provided by the PI. This section also includes overview information on the Thermochemical Conversion R&D Program, full scoring results and analysis, the Review Panel's summary report, and BETO's programmatic response.

BETO designated Andrea Bailey as the Thermochemical Conversion R&D Technology Area Review Lead. In this capacity, Ms. Bailey was responsible for all aspects of review planning and implementation.

THERMOCHEMICAL CONVERSION R&D OVERVIEW

The Thermochemical Conversion R&D session covered projects involving pathways that utilize bio-oil and gaseous intermediates to produce products, including finished fuels, fuel precursors, high-quality intermediates (e.g., sugars, syngas, or stabilized bio-oils), and high-value, biobased chemicals that enable fuels production.

Projects typically utilized one of the following high-temperature deconstruction technologies:

- **Pyrolysis** is the thermal and chemical decomposition of feedstock without the introduction of oxygen to produce a bio-oil intermediate. The bio-oil produced contains hydrocarbons of various lengths, but it contains more oxygenated compounds than petro-

leum crude oils and must undergo upgrading before it can be finished into a fuel or used in a refinery. BETO currently funds research on fast pyrolysis and catalytic (both in-situ and ex-situ) fast pyrolysis.

- **Liquefaction** is a deconstruction process that utilizes wet feedstock slurry under elevated temperature and pressure to produce a bio-oil.
- **Gasification** is the thermal deconstruction of biomass at high temperature (typically >700°C) in the presence of sub-stoichiometric air or an oxygen carrier, and sometimes steam, followed by gas cleanup and conditioning.

Some projects that utilize other intermediates or pathways were presented in this session due to similarities to other technologies.

THERMOCHEMICAL CONVERSION R&D REVIEW PANEL

Name	Affiliation
Shawn Freitas*	Thermochem Recovery International
Lorenz (Larry) Bauer	Independent Consultant
Timothy Brandvold	Abbott Molecular
Jeffrey J. Scheibel	Independent Consultant
Neils Udengaard	Haldor Topsøe (Retired)

*Lead Reviewer

TECHNOLOGY AREA SCORE RESULTS

Average Weighted Scores by Project

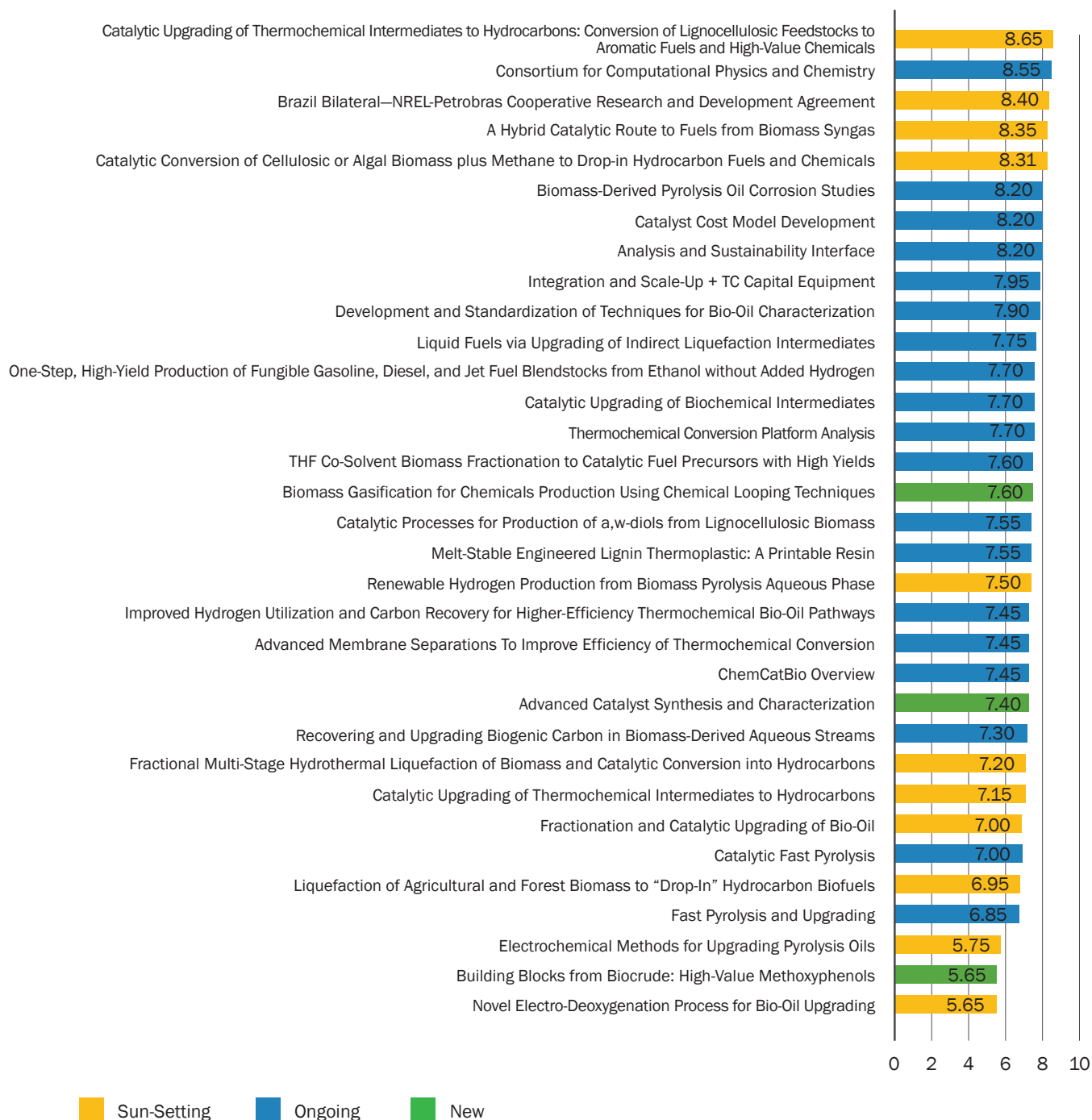

THERMOCHEMICAL CONVERSION R&D REVIEW PANEL SUMMARY REPORT

*Prepared by the Thermochemical Conversion R&D
Review Panel*

Impact

The Review Panel found that all of the projects reviewed were representative of the current state of the art for thermochemical conversions and reflected the industry-leading expertise and professionalism that has become the standard for BETO-funded work. In general, enough technological and operational progress was achieved in the 2015–2017 period that certain key thresholds and milestones were reached for some technologies, setting the stage for additional focus on successful pathways and reduced focus on others. With the lessons learned from these projects, constructive new developments in thermochemical conversions are very likely.

Advancing the State of the Art

The major thermochemical pathways represented in the current portfolio can be broken into three primary areas: liquefaction, gasification, and fast pyrolysis. These pathways are the most likely to contribute to reducing reliance on foreign oil imports, but they are also the most complex and face significant challenges for commercial adoption. The liquefaction and gasification projects in particular were ranked highly and viewed as leading the current state of the art. These technology areas have progressed significantly with BETO support and are viewed as having real commercial potential in the near to medium term. Continued focus on improving process efficiencies and generating high-value products in these areas will maintain the cutting-edge status this work currently represents. The fast pyrolysis work unquestionably represents the current state of the art. However, it was ranked lower due to the lack of evidence for

significant breakthroughs that would support the widespread commercial utilization of pyrolysis liquids as an alternative to oil. The successes with this technology clearly support its capabilities for efficient biomass deconstruction, but outside of isolated cases, the products generated from whole biomass have shown very little potential to become economically integrated into current fuel and chemical supply chains. Continuing to advance the state of the art for fast pyrolysis should be done by targeting biomass fractions like cellulose and lignin or by integrating new co-reactants into the processes to reduce reliance on hydrogen.

Torrefaction, slow pyrolysis, and thermomechanical refining are not currently represented in the portfolio, but these thermochemical pathways have significant potential to contribute to revitalizing the rural economy. Advanced cook stove and pellet heating objectives should also be considered as biomass is a fundamentally important source of heat for rural economies. These technology areas are compelling due their scalability and reduced process intensity, making them better suited for smaller-scale, distributed, and rural implementations. Additional BETO focus in these areas to advance the state of the art would positively contribute to several portfolio objectives important to the bioeconomy.

Relevance of BETO Focus Areas for Investment/Finance

Most of BETO's current focus areas, such as fast pyrolysis and gasification, require major capital investments for commercialization, typically in the hundreds of millions. Due to process intensity, significant economies of scale must be achieved, which necessarily increases the importance of efficiency, product value, and reduced risk profiles. Given major shifts in supply and demand associated with oil and gas resources in the last few years, a shift in BETO's focus may be necessary. With increases in supply due to fracking and decreases in value potentially associated with reduced hedging, the most practical insertion point for thermochemical products is no longer the front end of the refinery, but

further downstream. Thermochemical conversions that efficiently generate lower volumes of higher-value fuels and chemicals should be prioritized to adjust to shifting market needs. This places new importance on conversions pathways like liquefaction, both solvent and hydrothermal, as they are capable of efficiently generating a narrower selection of higher-value products. It also places additional pressure on fast pyrolysis to move away from solutions with a heavy reliance on hydrogen and towards solutions that can be economically implemented without relying on petroleum refineries. Adjusting to support cellulosic ethanol, industrial microbiology, wastewater, and pulp and paper facilities with thermochemical solutions is likely to improve finance options in the near to medium term. For the longer term, a revised look at where biomass can contribute to fuel, chemical, and heat supply chains so that smaller-scale, distributed approaches could be utilized should be considered, as this could improve options for finance. Biomass is a distributed resource and has a long history of being effectively monetized using rural/distributed approaches that are scaled based on access to sub-regional supplies.

High- and Low-Impact Directions

Scaling up a new process or technology from the bench, to a pilot, to a process demonstration, and then to commercial scales is not only difficult, but tends to contain so much uncertainty/risk that it often substantially limits investment options. From this perspective, reviewers identified the highest-impact directions related to projects making a significant effort to utilize existing commercial facilities or commercially relevant reactors to prove a conversion or catalysis step. Specific examples include the Brazil Bilateral—National Renewable Energy Laboratory Petrobras project, the Hybrid Catalytic Route to Fuels from Biomass Syngas project, and the Consortium for Computational Physics and Chemistry project. Opportunities to use commercial facilities are not common, but when possible, these projects should be given high priority as they will generate data critical-

ly important for accelerating the commercialization process. Generating finished products that can be used in existing engines and processes is also highly valuable.

From a technology perspective, one of the most compelling conversion areas currently in the portfolio is liquefaction. Some notable examples are the Catalytic Upgrading of Thermochemical Intermediates to Hydrocarbons: Conversion of Lignocellulosic Feedstocks project, the Tetrahydrofuran (THF) Co-Solvent Biomass Fractionation project and the Liquefaction of Agricultural and Forest Biomass to “Drop-In” Hydrocarbon Biofuels project. The last 3–5 years have seen some fairly significant improvements in solvent and hydrothermal liquefaction technology, and BETO’s support of this work appears to have pushed it towards an inflection point where commercial adoption is more likely. Improved solvent recovery, lower process intensity, and higher-value product options are all seen as constructive developments leading to increased interest in this area. This contrasts with much of the work relying heavily on hydrogen as a method to chemically force whole-biomass pyrolysis liquids into becoming hydrocarbons. The hydrocarbons generated from this hydrotreating are not as valuable as the synthetic hydrocarbons generated from syngas, and they are not as desired by petrochemical refineries because they are still chemically different enough from crude oil that they represent an unnecessary risk. While BETO’s expertise in hydrotreating biomass chemistries is a positive development with potential to enable new contributions to fuel and chemical supply chains, hydrotreating whole-biomass pyrolysis liquids as an alternative to oil is viewed as a low-impact direction unlikely to find wide commercial adoption.

Innovation

Current Thermochemical Innovations

Thermochemical conversions excel in the fast breakdown of large biomass polymers into smaller polymers and chemicals. As a function of this, they have the po-

tential to create chemical building blocks that can then be reassembled into large molecules and oligomers. This is attractive because these products often have more chemical functionality and different structures than those typically generated from a petrochemical refinery. Several well-regarded projects have been innovative in this area in ways that could be noticeably impactful in the future. Specific examples include the Liquid Fuels via Upgrading of Indirect Liquefaction Intermediates project and the Fractionation and Catalytic Upgrading of Bio-Oil project.

Thermochemical products are often highly reactive, but by performing separations and using this reactivity for targeted construction of useful chemicals and fuels, these projects are redefining some of the long-held assumptions about current fuel and chemical supply chains. Projects exploring alternative hydrogen donors to avoid traditional hydrotreating also show notable innovations, such as the Catalytic Conversion of Cellulosic or Algal Biomass plus Methane to Drop-in Hydrocarbon Fuels and Chemicals project and the Liquefaction of Agricultural and Forest Biomass to “Drop-in” Hydrocarbon Biofuels project. Alternative hydrogen donors are yet another way of exploiting the reactivity of thermochemical intermediates because the intermediates will more readily react with a much wider variety of chemicals than hydrocarbons. Innovations in this area promise to show that we can efficiently alter the composition of thermochemical breakdown products using different and more advantageous reactants.

Particularly interesting innovations are also occurring in projects exploring improved solvent recycling and in-situ solvent generation technologies for liquefaction processes, such as the Catalytic Upgrading of Thermochemical Intermediates to Hydrocarbons: Conversion of Lignocellulosic Feedstocks project, the THF Co-Solvent Biomass Fractionation project, and the Liquefaction of Agricultural and Forest Biomass to “Drop-in” Hydrocarbon Biofuels project. The Review Panel considers these developments critical for commercial adoption.

Necessary Future Innovations

To help advance thermochemical conversions to the next level, innovations related to chemical separations and narrowing product distribution are needed. Much like how petrochemical refineries are designed primarily to first separate and often refine the various components of crude oil before chemical modifications are made, a fresh look at how biomass separations can enable thermochemical conversions to generate more specific and higher-purity products must occur. As a result of a singular focus on up-front carbon efficiency associated with solid-to-liquid/gas conversions, innovation in this area has stalled. Too much emphasis has been placed on trying to refine mixed thermochemical biomass products as hydrocarbons and not enough has been done to explore separations unique to biomass and critical to the production of higher-value products. Biomass is easily separated into chemically distinct polymers, and avoiding this separation before conversion perpetuates the idea that thermochemical breakdown products are always crude and difficult to valorize. With additional focus and work to advance up-front separations, downstream separations will be less process intensive and far more likely to generate higher-value products. However, this does not preclude the additional necessity of innovations in downstream separations for pyrolysis liquids, which are fundamentally different than those that can be used for hydrocarbons. The value of a product is directly related to how expensive it is to produce, and separations are consistently one of the most expensive steps for generating fuel and chemical products. As such, further innovations in this area and potentially a new consortium are recommended.

Synergies

Current Synergies

There are currently numerous synergies between projects in the portfolio as a result of BETO’s consortium approach. Since 2013, BETO has steadily moved

toward creating more consortiums. This is a positive and high-impact shift that has reduced redundancies, improved standardization, and accelerated the rate of discovery and progress for all the major technological pathways currently in the portfolio. While not every project is suitable for a consortium, the national laboratories' work to create a shared understanding of TEA models, process models, mass and energy balances, cost models, analysis and characterization standards, and materials studies is impressive, and the Review Panel views this work as extremely important for building the industry. These areas are important for taking ideas from the laboratory and charting a path towards commercialization, and the consortiums are proving an efficient mechanism to not only develop these fundamentals, but to disseminate them in an interdisciplinary way across the BETO portfolio.

The greatest challenge this consortium approach currently faces is how to give projects outside the national laboratories access to the same synergies that are being enjoyed inside the national laboratories. Similarly, improving public dissemination of these projects' various models, standards, and studies must take a higher priority and grow beyond published papers and presentations and into open-source, web-based education and invited workshops where interested parties can directly interact with BETO resources and learn how to utilize these new tools. The Consortium for Computational Physics and Chemistry has done an exceptional job in this area and could be used as model for some of the newer consortiums. If pursued correctly, this is an opportunity to align the broader thermochemical community with a commonly shared set of tools and understanding, a foundation of functional synergies.

Necessary Future Synergies

The synergy between thermochemical and biochemical conversions is an increasingly important synergy that

must be addressed. The long-standing philosophy that thermochemical conversion does not require the same feedstock considerations as biochemical conversion has become limiting for thermochemical advancements. All biomass comminution steps and biomass chemical separations that benefit biochemical conversions will also benefit thermochemical conversions. Similarly, there are numerous opportunities for thermochemical conversions after biochemical conversions, as a way of improving overall process efficiency and economics. Low-value product streams from biochemical processes—including underutilized biomass fractions and fermentation cell mass—can often be thermochemically converted into additional products or low-cost biochemical feedstocks. A closer look at the fundamental needs each these conversion pathways requires for commercial success would likely reveal more similarities than differences and lead to constructive synergies. Areas highly likely to yield such overlaps are biomass separations, product separations, and utilization of downstream waste products.

Focus

Areas Requiring Additional Focus

Improving the domestic fuel supply chain through utilization of biomass means focusing on fuels and fuel infrastructure, which is very different than contributing alternatives to oil or general hydrocarbons. Furthermore, due to reactivity and structural differences, biomass chemistries are less likely to efficiently and economically contribute to lower-value commodity fuel supplies like diesel and gasoline, and they are more likely to contribute to high-performance and specialty areas like jet fuels, fuel additives, and solvents. Contributions in these areas are critically important to accommodate changing transportation trends and improved fuel economy. Two recent and particularly noteworthy examples of this are the use of hydrogenated pinene dimers as a biobased

blendstock for high-energy-density jet fuel JP-10^{25,26} and the use of dihydrolevoglucosenone as biobased performance solvent similar to N-Methyl-2-Pyrrolidone.^{27,28} Pinene is widely available as a byproduct of pulp and paper production, and levoglucosenone is a product of sugar pyrolysis. While neither of these examples has the potential to replace the barrel, they could absolutely contribute positively to the domestic supply of high-energy fuels and to the fuel production process. These examples offer proof that additional focus in the areas of jet fuels, fuel additives, and solvents is not only important, but could have the desired effects of growing the bioeconomy and leveraging domestic biomass resources to improve the fuel supply chain. BETO has been cultivating the expertise to contribute to these areas through focus in thermochemical conversion, hydrogenation, and targeted catalysis, but they have not yet become areas of specific focus. A recalibration based on lessons learned that leans toward high performance and specialty and less toward low-value commodity would likely yield near- to medium-term benefits and improve the probability of commercial adoption.

Areas to Consider Reduced Focus

Two areas needing less focus are hydrogenation of whole-biomass pyrolysis liquids and forced introduction of crude pyrolysis liquids into petrochemical refineries. Hydrogen is a highly valued and fully utilized reactant in commercial processes that require it. Its excessive use as an oxygen removal and stabilization tool for whole-biomass pyrolysis liquids is not practical as the product generated is not valuable enough to support this

level of process intensity. BETO has generated a considerable body of work validating this, and it would be more constructive to apply these techniques to different thermochemical process streams. Similarly, there is insufficient justification inputting pyrolysis liquids into petrochemical refineries as a crude-oil blendstock. Petrochemical refineries are designed to separate, refine, and often upgrade oils, but pyrolysis liquids are not oils, and their conversion into something more oil-like is expensive and complicated. BETO has considered multiple refinery insertion points for a number of years, and based on this work, BETO should reduce its focus on upstream crude-oil blendstock inputs and increase its focus on downstream finished-product blendstocks. This includes fuel additives like antioxidants, octane boosters, oxygenates, multifunctional additives, fuel oil additives, etc. Fuel at the pump is an engineered mixture with numerous components and fairly specific engine-related objectives. If possible, the focus should be on components of these various mixtures that can be generated more efficiently from biomass and thermochemical conversions.

Commercialization

Funding Philosophy

There is no indication that BETO is funding projects at the wrong stage of development, and in fact, based on the constructive growth of conversion areas like liquefaction, there is evidence that the funding philosophy is functioning as needed. Conversion technologies that have not been commercially adopted appear to face more

²⁵ Benjamin G. Harvey, Michael E. Wright, and Roxanne L. Quintana, "High-Density Renewable Fuels Based on the Selective Dimerization of Pinenes," *Energy & Fuels* 24, no. 1 (2009): 267–273, doi:[10.1021/ef900799c](https://doi.org/10.1021/ef900799c).

²⁶ Kale W. Harrison and Benjamin G. Harvey, "Renewable High Density Fuels Containing Tricyclic Sesquiterpanes and Alkyl Diamondoids," *Sustainable Energy & Fuels* 1, no. 3 (2017): 467–473, doi:[10.1039/C6SE00108D](https://doi.org/10.1039/C6SE00108D).

²⁷ James Sherwood, Mario De Bruyn, Andri Constantinou, Laurianne Moity, C. Rob McElroy, Thomas J. Farmer, Tony Duncan, et al., "Dihydrolevoglucosenone (Cyrene) as a Bio-Based Alternative for Dipolar Aprotic Solvents," *Chemical Communications* 50, no. 68 (2014): 9650–9652, doi:[10.1039/c4cc04133j](https://doi.org/10.1039/c4cc04133j).

²⁸ James H. Clark, Thomas J. Farmer, Andrew J. Hunt, and James Sherwood, "Opportunities for Bio-Based Solvents Created as Petrochemical and Fuel Products Transition towards Renewable Resources," *International Journal of Molecular Sciences* 16, no. 8 (2015): 17101–17159, doi:[10.3390/ijms160817101](https://doi.org/10.3390/ijms160817101).

challenges from market acceptance and market penetration issues than from issues with BETO funding. From a bioenergy and biofuels perspective, the current relationship between the Advanced Research Projects Agency – Energy (ARPA-E) and BETO looks to be complementary, keeping novel ideas flowing and down-selecting projects that have matured enough to appear ready for the next stage. BETO should continue to invest at the technology readiness levels (TRLs) that it has in the past and should also continue to enable growth in areas that help to realize its strategic fuels objectives associated with bioeconomy.

Enabling Commercialization

An aspect of commercialization that may need to be considered differently is product value versus market size. Most current approaches are supported by the idea that thermochemical technologies are needed to leverage the considerable biomass supply described by the 2016 Billion-Ton Report and to then feed as much biomass as possible into our domestic petrochemical refineries. This objective assumes that the products will not only be able to compete, but that they will also provide a benefit to the commodity fuels and chemicals markets that justifies the costs associated with change. The market is huge, but the margins are small, and the space is extremely competitive. This is maybe one of the most difficult objectives to choose for introducing a new chemical or material. It also demands that any new, high-risk commercial implementation is enormous so that it can benefit from economies of scale, which in turn makes investment challenging.

To increase the number of commercial successes using an unconventional chemical feedstock like biomass, BETO should consider focusing on product value and let market forces decide how large or small a market will become. There are a number of high-performance fuel, fuel additive, and specialty chemicals directions where biomass chemistries would offer natural strengths and, therefore, a value proposition worth maturing further. If BETO can succeed in increasing the number of commercially adopted technologies, even if the markets are initially

small, they will have contributed to building momentum towards the desired bioeconomy.

Another similar area is renewed focus on valorization of existing biorefining waste and product streams. Cellulosic ethanol, corn ethanol, industrial microbiology, wastewater, and pulp and paper facilities are all foundational in the current bioeconomy. Focus on underutilized byproducts and wastes is important because realizing more value from these outputs immediately improves process economics. Focus on existing product streams is also important because innovations here that lead to improved or new products can potentially expand options and capacity. Commercialization probability with this approach is high because these developments represent an improvement on in-place capital, so financing options will be numerous.

Recommendations

BETO has developed world-class capabilities in the fast pyrolysis area. These resources should be leveraged to advance fast pyrolysis beyond its current role as a front-end solid-to-liquids conversion step and towards a downstream role where more valuable, better-refined products are generated. Pyrolysis as a decomposition process has been utilized for precise conversions of various organic chemistries for well over a hundred years, and its relatively recent use to liquefy whole biomass has not been able to replicate that precision or utility. The substantial body of work on pyrolysis chemistries and the current proficiency at BETO for using and scaling up fast pyrolysis conversions suggests that greater things can be achieved if fast pyrolysis is not limited to generating low-value, mixed liquids that require significant upgrading. It is recommended that BETO work to realign current fast pyrolysis efforts towards conversion of biomass components representing various forms of lignin, cellulose, hemicellulose, and extractives. The Review Panel also recommends exploring co-reactants under fast pyrolysis conditions to expand or improve products. Advancements here have the

potential to noticeably improve both product distribution and product value, which would support improved commercialization efforts.

BETO catalysis projects and consortiums are strongly positioned to support compelling new developments in a wide range of biomass chemistry–related areas. These resources should work in concert with DOE fuel and engine researchers to find new ways to leverage biomass thermochemical products for improving the domestic fuel supply chain, particularly in higher-performance and specialty areas like jet fuels, fuel additives, and solvents. Fuel at the pump is an engineered mixture with numerous components and fairly specific turbine- or engine-related objectives. If some components of these various mixtures can be generated more efficiently from biomass and thermochemical conversions, focus on these chemistries would be constructive. It is recommended that BETO leverage its extensive abilities in both thermochemical conversion and chemical synthesis using thermochemical products to find new and better routes for generating turbine and engine fuel components, such as antioxidants, octane/cetane boosters, oxygenates, multifunctional additives, and fuel oil additives. Contributions in these areas are critically important to accommodate changing transportation trends and improved fuel economy and would have the desired effects of both growing the bioeconomy and leveraging domestic biomass resources to improve the fuel supply chain.

BETO works to revitalize the rural economy by finding new and better ways to enable biomass resources to contribute to the domestic fuel supply chain. Evolving manufacturing techniques, biomass harvesting options, and market needs suggest that in order to continue making an impact on this objective, BETO should consider shifting its project portfolio to include more technologies designed to function at smaller scales. Biomass is a distributed resource and has historically been effectively monetized using rural/distributed approaches, which are fundamentally different than the massive, centralized approaches that are more practical for oil- and gas-using pipelines. As options for manufacturing to de-centralize increase and biomass harvesting become more automated, technologies designed to convert biomass into chemical and fuel products at smaller scales will have a much higher probability of being commercialized and making an impact on rural economies. Furthermore, focused efforts to use thermochemical and biochemical conversions to improve the efficiency and economics of current corn ethanol, cellulosic ethanol, industrial microbiology, wastewater, and pulp and paper facilities would also make a positive contribution to the bioeconomy. The Review Panel recommends that BETO consider revising its portfolio strategy to better reflect some of the major developments occurring in the energy and manufacturing sectors. Additional focus on smaller-scale technologies and on opportunities to leverage underutilized and non-conventional sources of biomass would have a constructive impact on this objective.

THERMOCHEMICAL CONVERSION R&D PROGRAMMATIC RESPONSE

Introduction/Overview

Conversion R&D would like to take the opportunity to thank the five thermochemical conversion reviewers for their time and careful review of the portfolio. We

recognize that this was a difficult review process since additional projects relevant to this area were presented in other sessions due to time constraints. We have worked since the 2015 Project Peer Review to integrate biochemical- and thermochemical-based projects where possible and will continue this effort, taking the panel's recommendations for hybrid pathways into account. For future reviews, we may present projects with a hybrid

focus differently to give reviewers a better picture of the full portfolio. The Review Panel's recommendations will be discussed and taken into consideration when working on future project selection and program design, as future appropriations allow.

The Conversion R&D team recognizes that many of the issues with separations the Review Panel brings up are important barriers to achieving programmatic goals. A national laboratory consortium specifically working on the separations issues raised here presented in the Biochemical Conversion session, but was unable to present in the Thermochemical Conversion session due to time constraints. We will continue to prioritize R&D tackling pervasive separations challenges.

We appreciate the Review Panel's recommendation to increase focus in areas such as "torrefaction, slow pyrolysis, and thermomechanical refining," as well as cook stoves. Research on cook stoves has previously been funded as its own program in BETO, and additional research in this area would not fall under the scope of Conversion R&D. Expanding the portfolio to include additional technologies is subject to available funding, but the recommended areas will be discussed internally moving forward. Responses to the comments on current pyrolysis research and capital-intensive systems are presented in the sections below.

The following sections specifically address the three top recommendations from the Review Panel:

Recommendation 1: Re-Scope Pyrolysis Research

Much of the national laboratory pyrolysis research presented at this Peer Review has been scaling up in anticipation of the 2017 technology pathway verification, which will measure progress towards the Office's goal of an nth-plant modeled minimum fuel selling price (MFSP) of \$3/gasoline gallon equivalent (gge). Additional competitively funded projects working on fast pyrolysis also presented their final results at this review.

With this in mind, we agree that now is an ideal time to carefully consider the direction of future pyrolysis research.

As part of this process, Conversion R&D has already approached the national laboratory staff who have previously contributed to pyrolysis research to discuss their research moving into fiscal year (FY) 2018. The Chemical Catalysis for Bioenergy (ChemCatBio) consortium is increasing focus on other thermochemical and hybrid pathways and deemphasizing research on hydrotreating and other pyrolysis oil stabilization techniques moving forward. Conversations with outside stakeholders who have also provided valuable guidance in the past on pyrolysis research will also be used when developing this new strategy.

Though pyrolysis research will be deemphasized to an extent, we will continue to advance modeling efforts related to pyrolysis on particle heating, hydrodynamics, and other reaction-level mechanisms. We appreciate the Review Panel's feedback on the utility of these computational efforts and will use them to help guide decision making on the recommended potential pathways for pyrolysis research suggested by the panel.

Recommendation 2: Increase the Value Proposition of Biomass

Conversion R&D agrees that additional research should be targeted at increasing the value proposition of biomass by synthesizing higher-value products like fuel additives or chemicals that are closer in structure to biomass feedstocks. Since the 2015 Peer Review, we have kicked off a number of new efforts to begin moving in this direction.

The MEGA-BIO: Bioproducts To Enable Biofuels funding opportunity announcement (FOA), awarded in FY 2016, supported the development of biomass-to-hydrocarbon biofuels conversion pathways that can produce variable amounts of fuels and/or products based on external factors, such as market demand. This effort

to expand the portfolio to include projects that can supplement the development of fuels by tapping into bioproduct markets has further expanded with internal and national laboratory analyses (some of which were presented in other review sessions) on the market potential of bioproducts. The Conversion R&D team has also integrated feedback on bioproducts into broader goals present in the Office-wide 2016 *Strategic Plan for a Thriving and Sustainable Bioeconomy* and continues to seek feedback on products, in addition to fuels, at listening days and workshops.

In June 2017, Conversion R&D also held a workshop focused specifically on performance-advantaged bioproducts, including functional replacements, targeting products that could be made from biomass feedstocks that offer a performance advantage over petroleum-based products. This input will be integrated into the design of future projects as funding allows.

The Conversion R&D team also recognizes that there is overlap between potential research in higher-value fuels and work being done by the Co-Optimization of Fuels and Engines initiative. We will continue to collaborate with the Co-Optimization of Fuels and Engines initiative to avoid duplication and provide input where relevant.

While we plan to take these recommendations into account, it is also important to note that at the time of this review, cost targets for finished hydrocarbon fuels

remain the main driver of R&D. However, given persistent low oil prices, and the importance of flexibility in directing research to areas where it can be the most impactful, alternative success measures are also being considered.

Recommendation 3: Leverage “Waste” Streams and Existing Capital Resources

The Conversion R&D team appreciates this recommendation and recognizes its potential to reduce the large capital costs associated with many potential biorefinery projects, while also valorizing undervalued feedstocks. Much of the Conversion R&D Program’s research on potential “waste” streams was reviewed in the Waste-to-Energy session. This portion of the Conversion R&D portfolio covers projects utilizing municipal, industrial, and agricultural wastes. By design, many of these waste streams come from facilities ideal for the co-location recommended by the panel.

The Office, as a whole, has also made an effort to solicit more projects on modular systems or projects that can take advantage of existing infrastructure. Some of these efforts either were not eligible for this review because they are too new or were reviewed in other sessions.

As the 2017 pathway verification effort draws to a close, we will also look into ways to take this recommendation into account, potentially utilizing more existing infrastructure and avoiding large capital costs.

ANALYSIS AND SUSTAINABILITY INTERFACE

(WBS #: 2.1.0.301)

Project Description

This project provides technical, economic, and sustainability analysis for biomass conversion routes to hydrocarbon fuels and chemicals in order to direct research toward high-impact results. Pacific Northwest National Laboratory develops target conceptual biorefinery models with researcher input and compares them against benchmark models that incorporate currently achieved research results. This (1) identifies barriers, cost-reduction strategies, sustainability impacts; (2) helps to set technical and costs targets; and (3) tracks research progress. Frequent, close interactions with researchers to review sustainable cost-reduction strategies are necessary. Key specific outcomes are the publication of the target design case and the annual state of research technology

Recipient:	Pacific Northwest National Laboratory
Principal Investigator:	Sue Jones
Project Dates:	7/27/2006–9/30/2016
Project Category:	Ongoing
Project Type:	Annual Operating Plan
DOE Funding FY 2014:	\$125,000
DOE Funding FY 2015:	\$725,000
DOE Funding FY 2016:	\$875,000
DOE Funding FY 2017:	\$925,000

reporting for pyrolysis oil upgrading towards meeting the BETO FY 2017 goal of \$3/gge on a modeled mature technology basis. Also supported is catalysis (conversion of oxygenated intermediates) and biochemical (fungal conversion) research to develop targets and track progress towards the 2022 BETO goals. Interactions with researchers and analysts at Argonne National Laboratory, Idaho National Laboratory, the National Renewable Energy Laboratory, and other BETO-funded laboratories enhance project effectiveness.

Weighted Project Score: 8.2

Weighting: For ongoing projects, there is equal weighting across all four evaluation criteria: Approach, Relevance, Accomplishments and Progress, and Future Work.

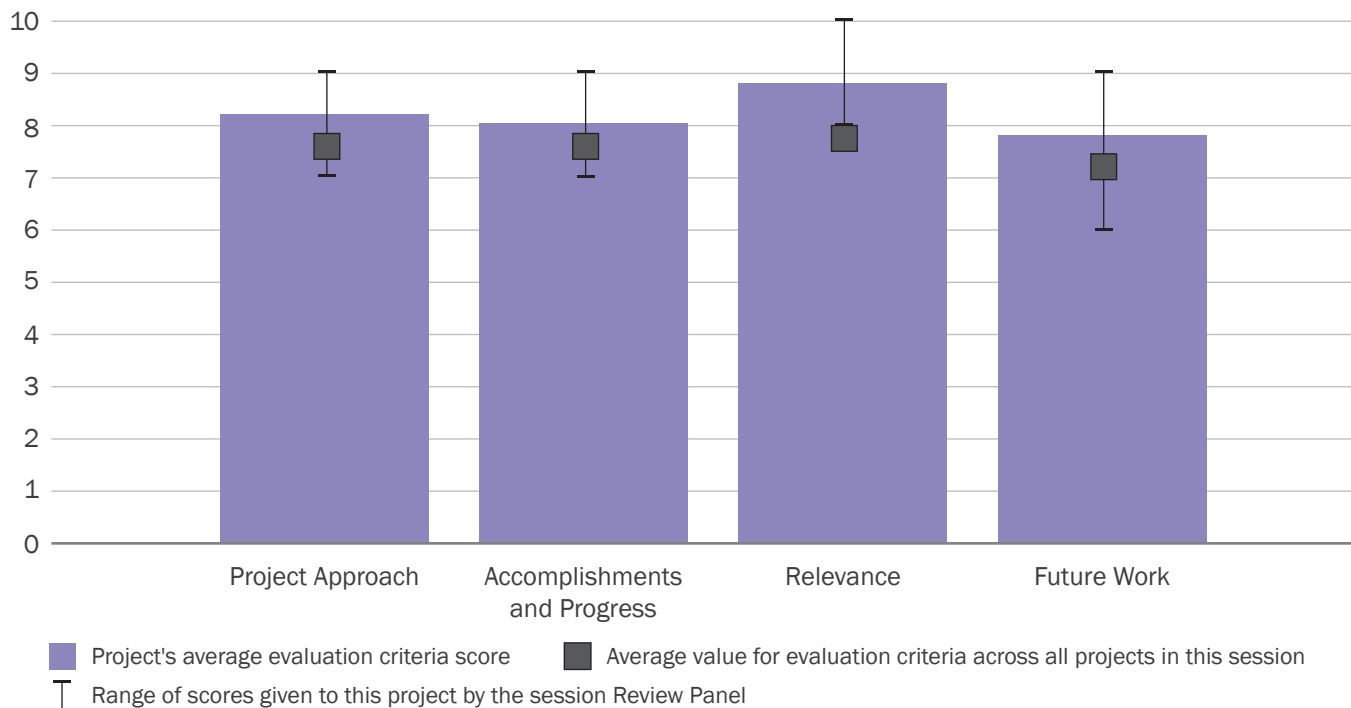

Overall Impressions

- The team demonstrated solid organization both at working and management levels, as well as excellent communication across teams working with the principal investigators (PIs). The feedback mechanisms are solid, as proven by the results of directing PIs toward the right tasks to maximize results and minimize money spent to achieve BETO's goals. There is no indication of weaknesses since the last review's positive feedback in 2015. This project is a well-oiled machine that is even already showing results on task 3 modeling: fungal approach. It might even be useful at some point to share with parts of industry how this team has managed to do so much in a short time frame. Often modeling efforts are not fast enough in industry to impact team direction in a significant way.
- Overall, this is a strong project with very positive impact for the biofuel community. It allows comparisons between different routes on the same basis and can direct research towards the least-costly routes to biofuels.

I am concerned that the results will be taken too literally by outside groups. The model does not take into account the development risks associated with the given routes including outside market factors, application of novel technologies, design complexity, and potential operation issues. The results of the verification study are correctly identified as the critical success factor. Allowing public access to the spreadsheets would be a great additional task for this program, as would open access to the Aspen modeling work.

- This is an excellent project that is/will greatly benefit and provide valuable guidance for overcoming technology and cost barriers in several other bio-energy projects. The project is well managed with clear objectives and goals, as well as milestones. Coordination with multiple national laboratories and research organizations ensures a broad and diverse knowledge base.
- Overall, project relevance is greater than what was suggested in presentation. Models such as these not only help focus catalyst research, but also reactor design, process design, and target product selection. Additionally, they contribute towards streamlining and improving R&D efficiencies, a critical cost-saving measure.
- Well-planned and executed project. Key challenge is ensuring models are used consistently to guide decision making in support of technical project and DOE program objectives.

PI Response to Reviewer Comments

- We thank the reviewers for their thoughtful and informative comments. We agree that although n-plant analysis assists research focus at the laboratory level, the commercial maturity level can be misunderstood. While this is addressed in the design reports and emphasized in presentations, the need to understand the cost implications for first-of-a-kind plants should be clarified and perhaps could best be handled through public-private partnerships. Public availability of the analysis from this project is a key goal, and we are making progress through increased publications and presentations. While model maintenance for public use is not funded within this project, we do share detailed information with stakeholders when appropriate.

THERMOCHEMICAL CONVERSION PLATFORM ANALYSIS

(WBS#: 2.1.0.302)

Project Description

The National Renewable Energy Laboratory's (NREL's) Thermochemical Platform Analysis provides process design and techno-economic analysis (TEA) for the Thermochemical Conversion Platform to inform and guide NREL/BETO R&D priorities. TEA provides a consistent, business-relevant basis for comparing diverse conversion options through use of process and economic models, which translate key technical parameters into overall economics (dollars and cents). TEA results are used for setting future R&D targets and evaluating experimental progress and any deficiencies against those targets. Outcomes of integrated TEA modeling

Recipient:	National Renewable Energy Laboratory
Principal Investigator:	Michael Talmadge
Project Dates:	5/30/2002–9/30/2016
Project Category:	Ongoing
Project Type:	Annual Operating Plan
DOE Funding FY 2014:	\$1,350,000
DOE Funding FY 2015:	\$2,000,000
DOE Funding FY 2016:	\$1,900,000
DOE Funding FY 2017:	\$1,950,000

are utilized by BETO to guide program plans, and by other NREL/partner projects to quantify the impact of research on key technology barriers. This work is highly relevant to BETO goals as TEA directly informs, supports, and guides R&D for cost-competitive fuels and products. By providing a framework to translate technical performance into cost reductions within conceptual biorefinery designs, our TEA models are leveraged to direct R&D towards the most economically impactful

Weighted Project Score: 7.7

Weighting: For ongoing projects, there is equal weighting across all four evaluation criteria: Approach, Relevance, Accomplishments and Progress, and Future Work.

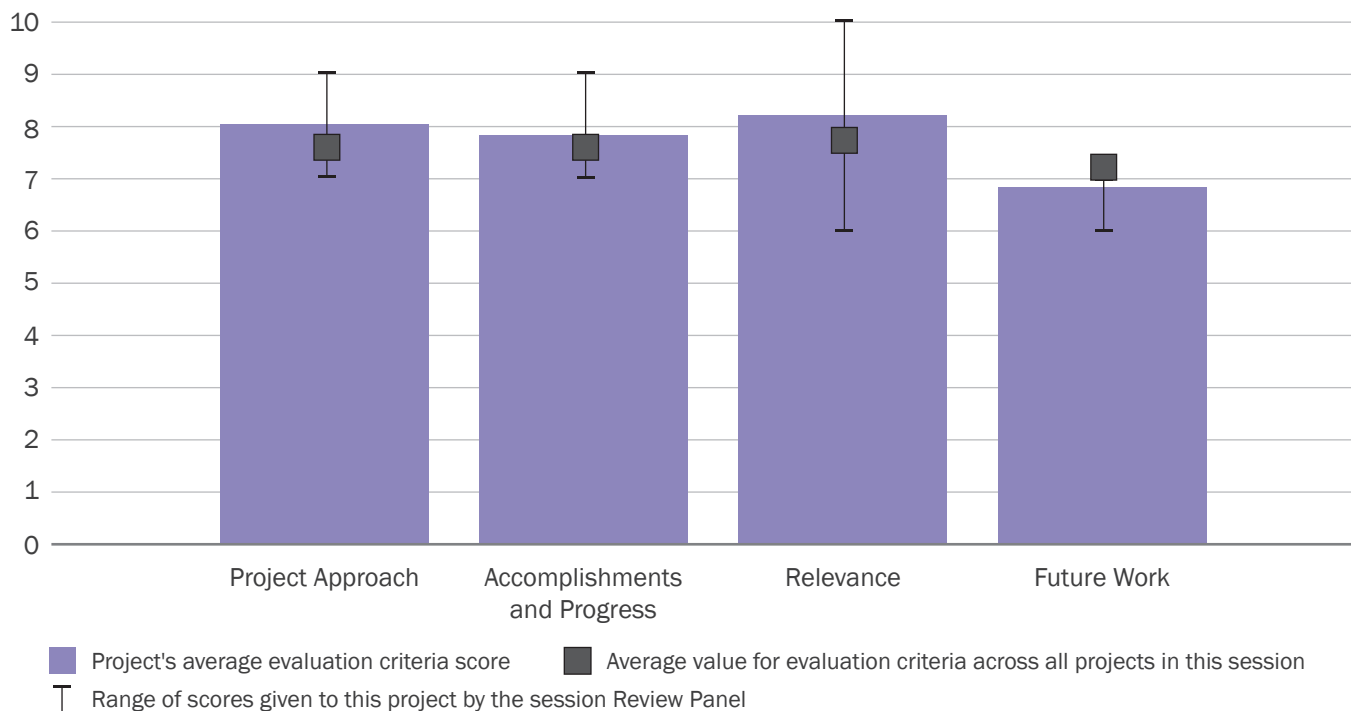

outcomes. This project has made major achievements since the 2015 Peer Review, including completing state-of-technology assessments to quantify R&D cost reductions on catalytic fast pyrolysis and indirect liquefaction pathways, sensitivity analysis for process alternatives, development of new analysis capabilities, and future scope for developing complex, industry-relevant, market-responsive biorefinery designs.

Overall Impressions

- It is a large team and working on so many different aspects to impact the programs, making it hard for the reviewer to fully understand team impact in such a short review time and slides. The examples were helpful, but perhaps showing more examples would have been more helpful for reviewing the team's accomplishments. I understand, however, that it can be hard to show lots of smaller contributions the team has made. I do believe modeling is key and critical to the success of projects. Early modeling is also critical, but I caution that with insufficient data, the modeling can be misleading to teams. Keep focusing on this area as key to drive success.
- This is a very strong project with a history of successfully providing key information. I have found that the results from the earlier part of the projects matched the results from the analysis from my similar process development work.
- It would be great if there was a method for accessing the resulting tools interactively to evaluate outside work. However, the fast turnaround analysis portion of the program could help with this kind of request. I am concerned that the dollar amounts for the sale price resulting from the model are misleading due to failure to include risk and other outside factors that influence the value.
- The project provides excellent information and evaluations that will help other bioenergy projects to focus on relevant targets. The project is well-managed with clearly defined barriers and critical issues.

- Overall, TEA models are notoriously complex and hard to replicate because, like all models, they are only as good as the data you put into them, and the more they encompass, the more complex they are, which tends to decrease the probability that their predictions will be accurate. It is validating that these models have already been shown to improve some existing BETO projects, but more cases should be run and additional validation should be completed using existing industrial processes.
- This is a good project. I'd like to see some discussion of how the tools (TEA, phase equilibria, kinetic modelling) are evaluated independently of the technical projects, possibly by benchmarking against well-understood technologies. While none of these will be used alone to make key program decisions, DOE wants to make sure the models are pointing in the correct direction.

PI Response to Reviewer Comments

- Thank you for your helpful feedback and guidance. The project team agrees with the reviewer feedback and recognizes the challenges in assessing risks and uncertainties associated with capital and operating costs for emerging technologies, operational learning curves in early stages of commercial deployment, and inherent uncertainties in projecting mature plant economics based on early-stage R&D. In this context, we will continue to engage experts from industry, academia, and partner laboratories to ensure that analysis continues to maintain high quality and transparency and that we make improvements based on critical feedback. Per the reviewers' recommendations, we will increase focus on smaller-scale conversion systems, while studying in parallel how technologies might integrate into more complex, industry-relevant designs for the co-production of fuels and products.

The project team appreciates the recommendation to increase benchmarking with developed technol-

ogies and will seek opportunities to improve this aspect of the project. The team develops capital and operating cost structures for biomass conversion pathways by often leveraging published industrial data on capital and operating costs for comparable commercially mature technologies. In order to complement the ground-up approach for capital costs for new technologies, the team compares costs with similar industrial technologies where relevant, e.g., utilizing published data on capital costs for various mature catalytic reforming units (semi-regeneration, cyclic-regeneration, and continuous-regeneration) to assess capital costs for low-pressure vapor swing-reactor systems in biomass conversion processes.

To address the challenge of industry confidentiality regarding catalyst costs, the TEA team is leveraging the Catalyst Cost Model being developed under ChemCatBio (that project also has critical industrial input). The development of TEA for the co-processing of pyrolysis oil in a fluid catalytic cracking unit

is a good example where we benchmarked relative to commercial fluid catalytic cracking units before extending analysis to pyrolysis-oil co-processing.

The project team also maintains and utilizes capabilities to assess biorefinery economic scenarios outside of the mature/nth-plant basis. While we do not regularly report pioneer plant economics, we provide this information to BETO whenever it is necessary to extend our economic projections to pioneer plants. In this context, we also worked with industry partners to develop TEAs for the immediate (first-of-a-kind plant) integration of bio-intermediates into the existing petroleum refining infrastructure, as well as the commercial deployment of syngas-derived products based on NREL's catalyst R&D.

As detailed in previous responses, the team will also continue to identify and utilize channels for presenting our work, disseminating our models/tools in the public domain, and seeking collaborative projects with industry partners.

LIQUEFACTION OF AGRICULTURAL AND FOREST BIOMASS TO “DROP-IN” HYDROCARBON BIOFUELS

(WBS#: 2.2.2.401)

Project Description

Iowa State University has developed and implemented a continuous pilot-scale process in which loblolly pine is converted to a partially deoxygenated bio-oil via solvent liquefaction. The primary objective of this project is to convert the pine feed to a bio-oil containing less than 20 weight percent (wt%) oxygen at a 50 wt% yield using a recycled wood oil product. This bio-oil will then be hydroprocessed to biocrude and upgraded to gasoline- and diesel-range hydrocarbons. The pilot-scale system generated three unique cuts of bio-oil (light, medium, and heavy wood oil), an aqueous fraction, non-condensable gaseous products, and bio-char. Biomass and solvent (hydrocarbon and wood oil) were fed to the

Recipient:	Iowa State University of Science and Technology
Principal Investigator:	Ryan Smith
Project Dates:	1/1/2013–12/31/2015
Project Category:	Sun-setting
Project Type:	FY 2011–BRDI: DE-FOA-0000510
Total DOE Funding:	\$3,500,000

liquefaction unit at rates of 0.5–1 kg/hour and 2–4 kg/hour, respectively. The liquefaction unit was operated between 300°–400°C and 27–48 bar. Preliminary experiments utilizing a hydrocarbon solvent resulted in a biomass conversion of 83.5% and mass closure of 99.8 wt%. Bio-oil yield was 55.3 wt%, surpassing the project goal of 50.0 wt%. Initial moisture-free and solvent-free elemental analysis of a mixture of light, medium, and heavy wood oil determined the oxygen content to be 19.7 wt%. The use of recycled wood oil as a solvent has not yet been conducted in the pilot-scale system. Instead, a surrogate recycled wood oil has been used in the solvent mix to simulate product recycle. The result was

Weighted Project Score: 7.0

Weighting: Approach–25%; Relevance–25%; Accomplishments and Progress–50%.

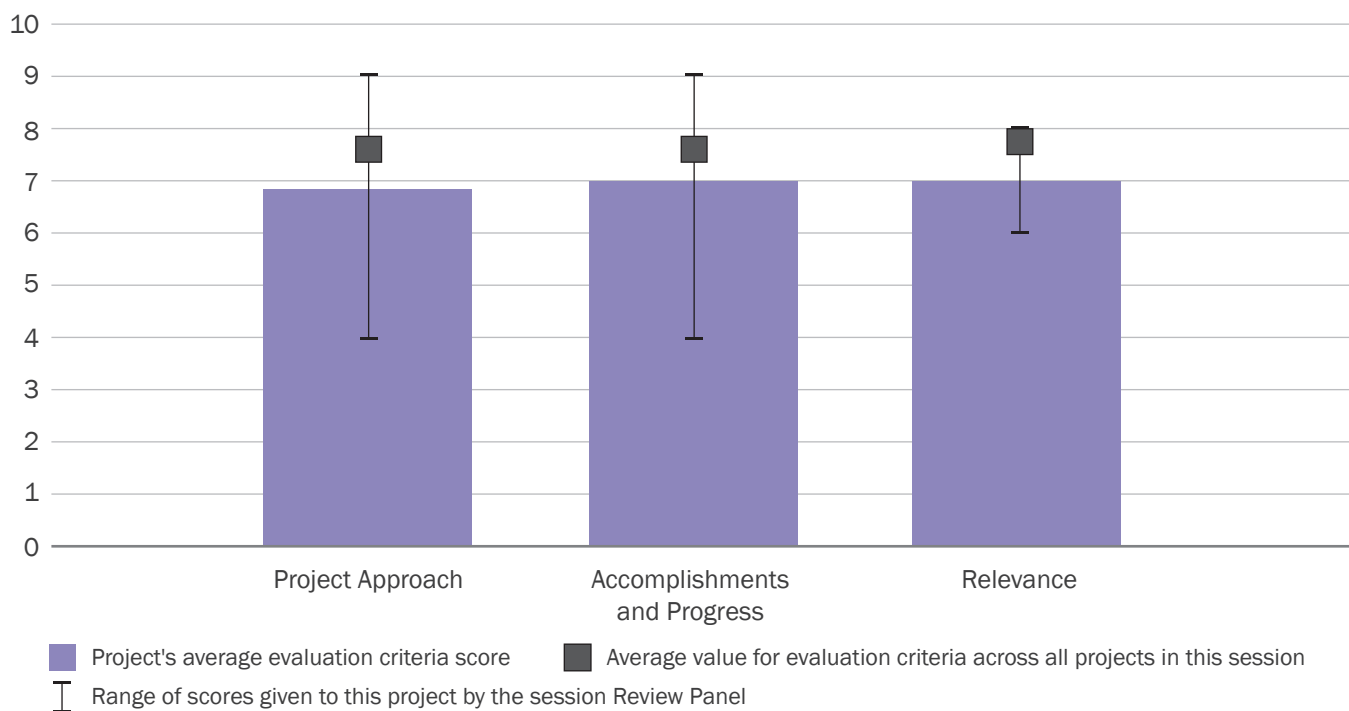



an increase in biomass conversion to 91.0% and mass closure of 93.6 wt%.

Overall Impressions

- Excellent work results show the utility of solvent liquefaction, which has been standard in coal liquefaction. The key will be whether the economics for biomass match that for existing coal liquefaction practiced today. I would also like to see environmental impact studies run also in parallel to techno-economic analysis (TEA), as these types of processes have quite a bit of chemical solvent moving around the system and should require cleanup at some time after longer use. Although the project is ending, it is key to get the following final information:
 - Bio-oil upgrading catalyst work—it will be interesting to see if constraints on poisons are reduced by solvent processing.
 - TEA is not yet defined, so claim of less than \$3/gallon should not be made yet.
 - Exploring lignin conversion should fit well with results from coal liquefaction.

- The project confirmed that high-pressure thermal solvolysis can produce good yields of a bio-oil with high carbon retention. This approach is one of the most promising of those being studied. However, the project failed to meet many of its stated goals of exploring upgrading the products by hydroprocessing and using an actual recycle stream. More importantly, there was no TEA analysis to allow the technology to be compared with other approaches.
- Project appears almost completed, but future tasks are still listed? The results so far are encouraging, but time will show how this technology will be accepted as a competitive alternative.
- Overall, this is a very compelling project. Process uses relatively mild temperatures and pressures, which dramatically improves its commercial potential. Future publications that explain solvent chemistry and mechanisms will provide important insights regarding the contribution of this work to the pyrolysis community.
- While the technical achievements of this project were limited, successful biomass upgrading technology will likely utilize the concepts incorporated in this project.

PI Response to Reviewer Comments

- The less than \$3/gallon figure is a target, and the TEA will be included in the final report.

Regarding future work, results so far are encouraging, but time will show how this technology will be accepted as a competitive alternative.

The project officially ends June 30, 2017, leaving time to conduct the hydroprocessing work and finalize the TEA results, which are currently underway.

THF CO-SOLVENT BIOMASS FRACTIONATION TO CATALYTIC FUEL PRECURSORS WITH HIGH YIELDS

(WBS#: 2.2.4.400)

Project Description

The overall goal of this project is to advance transformative co-solvent enhanced lignocellulosic fractionation technology to achieve high yields of fuel precursors, such as furfural and 5-hydroxymethylfurfural, from hardwood poplar and their conversion to “drop-in” fungible fuel blendstocks (methylated furans, higher alcohols, and hydrocarbons). The project will concurrently capitalize on the co-solvent enhanced lignocellulosic fractionation process’s extremely high lignin-extraction capability to produce liquid fuels and aromatic platform chemicals from lignin to increase process revenues. The project will be divided into two budget periods, lasting 12 months (1 year) each, and four main tasks

Recipient:	University of California, Riverside
Principal Investigator:	Charles Wyman
Project Dates:	9/1/2015–2/28/2018
Project Category:	Ongoing
Project Type:	FY 2013—Incubator: DE-FOA-0000974
Total DOE Funding:	\$1,060,000
DOE Funding FY 2015:	\$1,185,000
DOE Funding FY 2016:	\$1,190,000
DOE Funding FY 2017:	\$1,190,000

corresponding to the four project milestones, including a techno-economic analysis.

Overall Impressions

- This is a very impressive work result for a first year or so effort. I like the solvent/catalyst approach as it makes the best utilization of biomass and lignin and fits with other work on transformations in the BETO programs. The team has done an outstanding job. I do think the team needs to present what they

Weighted Project Score: 7.6

Weighting: For ongoing projects, there is equal weighting across all four evaluation criteria: Approach, Relevance, Accomplishments and Progress, and Future Work.

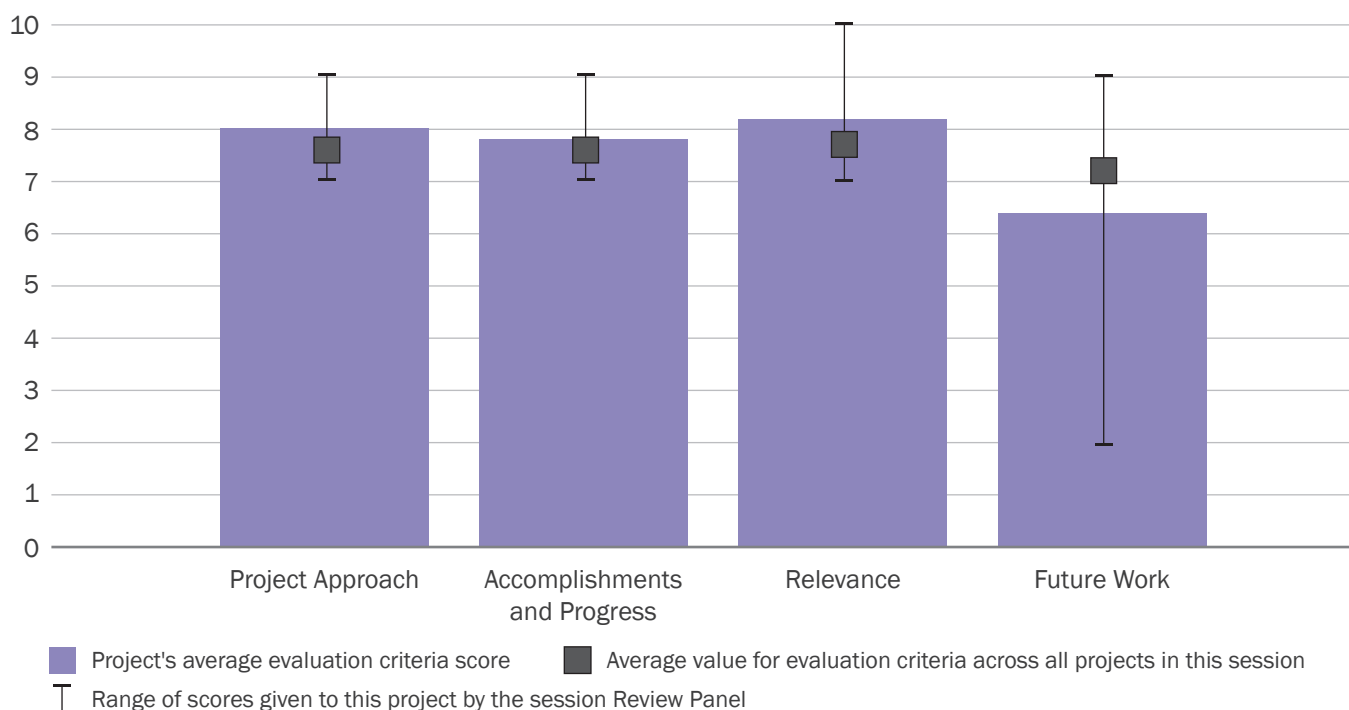

believe are killer issues, which were not addressed in this review: (1) solvent impact on market and (2) contribution cost to raw material cost of solvent easily calculated at various levels (such as 80%, 90%, 100% recovery) without using fancy modeling. The same could be said for (3) defining cost and market impact on iron halide use and recovery. These are simple calculations that can be done by any scientist for an early rough estimate. I believe, however, that this team has a right to succeed in their program in the next year or more, but the key will be the future economic assessment and solvent recovery results.

- This project is off to very good start but will need some input from people with more commercial experience. The potential of the approach was clearly demonstrated. I am concerned with the use of THF as solvent in terms of both cost and safety. The techno-economic analysis done so far is not very strong and could use input from the BETO consortium. The project could also use input from people with commercial experience.
- This is an interesting project for the longer term. There are still many issues that need to be solved and demonstrated before the technology is ready for commercialization.
- Overall, this is a very compelling addition to the organosolv liquefaction community. The choice of THF as solvent was well thought out and supports very efficient recovery and reuse of solvent. However, while this is very effective chemistry, lessons need to be learned from the industrial furfural and furfuryl alcohol industries. Understanding the commercially relevant routes for furfural and furfuryl alcohol derivatives, as well as the existing markets, needs to be part of the design decision-making

process. THF is also a classic example of a solvent where great power comes with great responsibility—it is frequently avoided at commercial scales for its volatility, flammability, and generally hazardous nature. This must be considered more in the future.

- Overall, this is a nice project showing reasonable progress by processing biomass feedstocks in parallel. But, it needs to consider transitioning from a reaction to a process.

PI Response to Reviewer Comments

- We would love to be able to collaborate with groups specialized in performing techno-economic analysis if permitted by BETO management. Our project is currently being advised by commercial partner MG Fuels, who is committed to commercializing the co-solvent enhanced lignocellulosic fractionation process in North America and has begun pilot-scale testing based on our experimental results.

We have already performed high-level economic analysis of raw material costs, as reported in our Quarter 2–Quarter 4 reports, demonstrating positive cash flow and reasonable operating margins (suitable for return on investment of <5 years) using experimentally derived yield data and solvent recycle efficiencies.

We have mentioned strategies we have implemented in our proposed process design to mitigate the dangers of THF usage in our responses for sections 1, 2, and 3.

We are working with our commercial partner, MG Fuels, to achieve our laboratory results at a continuously operated pilot scale.

CATALYTIC UPGRADING OF BIOCHEMICAL INTERMEDIATES

(WBS#: 2.3.1.100-3)

Project Description

The Catalytic Upgrading of Biochemical Intermediates project is a multi-laboratory effort within ChemCatBio that is specifically focused on catalytic upgrading of sugars/related intermediates from biochemical deconstruction and/or biologically derived (i.e., fermentation) intermediates to hydrocarbon fuels. As several companies are developing catalytic upgrading routes from clean sugars, this project will help facilitate a transition to catalytic upgrading of biomass-derived intermediates by providing a quantitative performance and economic assessment of several catalytic upgrading approaches using biochemical deconstruction/fermentation intermediates.

While there are strong reasons for use of biochemical conversion—appropriate feedstocks and deconstruction

Recipient:	National Renewable Energy Laboratory, Oak Ridge National Laboratory, Los Alamos National Laboratory, Pacific Northwest National Laboratory
Principal Investigator:	Rick Elander
Project Dates:	7/25/2011–9/30/2019
Project Category:	Ongoing
Project Type:	Annual Operating Plan
DOE Funding FY 2014:	\$950,000
DOE Funding FY 2015:	\$2,100,000
DOE Funding FY 2016:	\$2,100,000
DOE Funding FY 2017:	\$1,950,000

methods, numerous challenges exist, including integration of biochemical upstream and catalytic downstream operations; understanding inhibitory impacts on upstream and downstream operations; developing specifications for biochemically derived feed streams to catalytic processes; and quantifying impacts of such

Weighted Project Score: 7.7

Weighting: For ongoing projects, there is equal weighting across all four evaluation criteria: Approach, Relevance, Accomplishments and Progress, and Future Work.

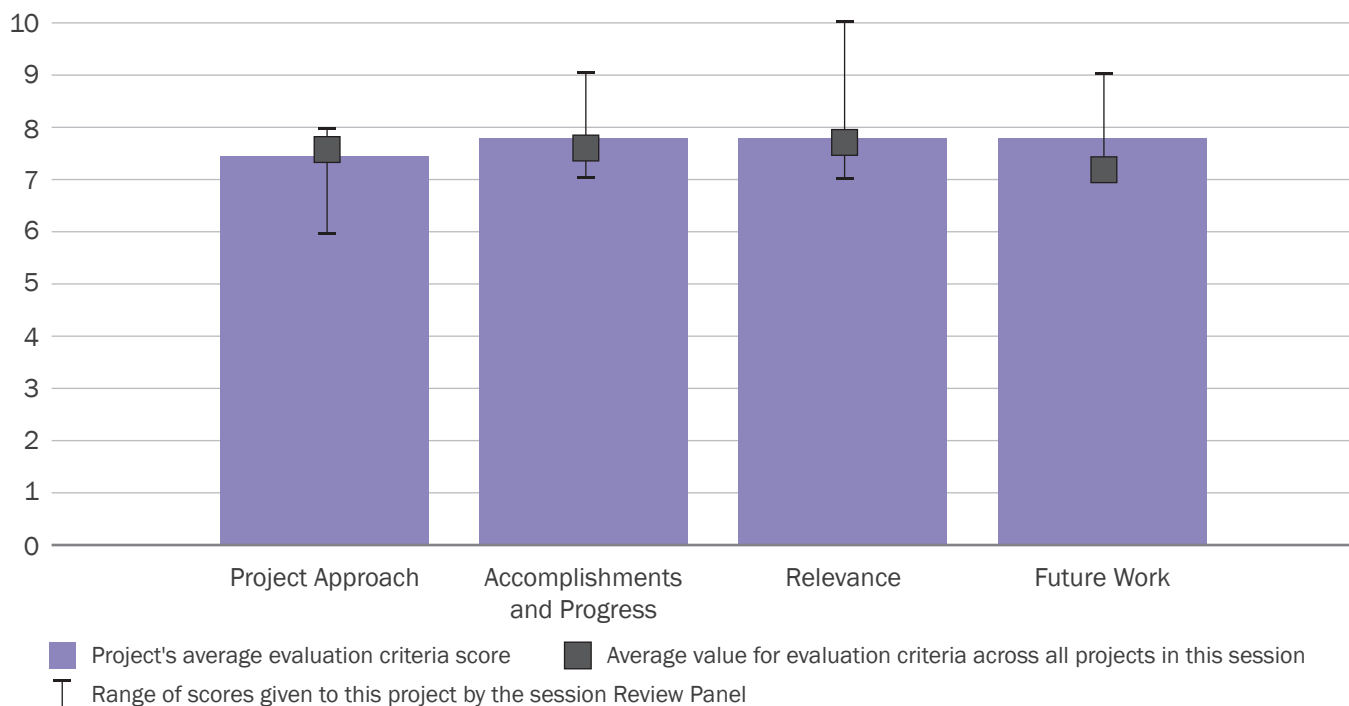



feed-streams on catalyst durability/lifetime, efficiency, and selectivity. The main project outcome will be the evaluation of four routes for catalytic upgrading of sugars and sugar-derived intermediates into hydrocarbon fuels and co-products and select routes(s) that can achieve hydrocarbon fuel costs of \$3/gge in 2022 (when coupled with lignin co-product valorization), with >25% (gge basis) in the jet or diesel range.

Overall Impressions

- The teams have done a great job in exploring the potential routes feasible that will maximize the use of all the carbon versus other approaches. I see this approach overall as having best chance to be successful in the long term if sufficient funds continue to be put into this program. It requires complex chemistry to achieve all the processing steps commercially at economics, but the team has the right approach to narrow the possibilities and should continue to attempt to combine steps into one or two where feasible. Initially some carbon loss may occur, but the key challenge for this approach will be the capital necessary for all the unit operations. The team did the best job in their presentation in providing summary slide of approach, accomplishments, relevance, and future work. Ethanol utilization was highlighted from the last review but will be most economically challenging, even in the

future, for cellulosic-derived ethanol. The cost of producing cellulosic ethanol by fermentation and the fermentation cost need to be defined if this will even be close to ever meeting the cost needed in the future. Chemical processes are much easier to predict on scale-up, so my key cautionary statement to the team is from my past teams' experience—the fermentation piece will be easy early on, as shown, while catalyst conversion will be more challenging early on in program. In the long run, chemical processes are more readily scaled than biological ones, from my experience.

- This project continues to produce important results. The production of biochemical intermediates and their conversion to chemicals and fuels is increasingly recognized as the most promising route for replacing fossil fuels with biomass. This route is the best suited to take advantage of the available biomass and the potential growth in high yield varieties grown specifically for fuels, as outlined in the 2016 *Billion-Ton Report*.

The project has clearly demonstrated the chemistry can work. The focus should begin to shift towards optimizing the process to provide data to the techno-economic analysis (TEA) by choice of catalyst and reactor conditions. Scale-up to produce sufficient quantities to allow product evaluation should be considered as a next step.

There is significant prior work involving these routes. The next step should be to place these in a commercial context and conduct careful TEA on the same basis. The performance of each of the routes needs to be benchmarked against the prior work both in government and in outside laboratories.

Most of the biomass the fuel processes produce light oxygenates that can be upgraded to fuel via these routes, making this project relevant across many platforms.

- This is a well-organized project with clear goals. The project will provide an excellent knowledge basis that will enhance the chance of making bioenergy projects successful. The project leverages on experience from several national laboratories.
- Overall, great work—this program’s focus on sugar conversions is showing that it can efficiently produce narrow product distributions and also products with high potential value. This is a result that continues to elude whole-biomass conversion and therefore is a solid step forward in a constructive direction. However, technical success is different than commercial or strategic success, and the number of steps required to take sugars all the way to hydrocarbon fuels is concerning. Looking at biomass sugars and selecting conversion targets that could be produced with the least steps, in a thermodynamically favorable way, is a logical approach for reducing process intensity and improving the odds of commercial/strategic success. It is possible that the program would contribute to the fuel supply in a more constructive manner if focus was on increasing availability/decreasing costs of fuel additives like antioxidants, octane boosters, multifunctional additives, fuel oil additives, etc. Fuel is not a neat chemical; it is an engineered mixture with numerous components, and if there are components that can be generated more efficiently from sugars than petroleum, that would be most helpful.
- This is a big, ambitious project focusing on conversion strategies. Good technical work demonstrated to date.

PI Response to Reviewer Comments

- We thank the Review Panel for their supportive and constructive comments regarding this project. We are evaluating and developing a targeted range of process routes to exploit the specificity of intermediate compounds associated with bio-

chemical deconstruction and biological upgrading of biomass to target more specific fuel compounds and blendstocks. This is one of the key advantages afforded by the generation of biochemically derived intermediates. We agree with the Review Panel’s recommendation to identify potentially higher-value fuel additives, oxygenates, octane boosters, etc., and we will work with BETO technical managers, other projects within the ChemCatBio project landscape, other relevant projects within the BETO portfolio (such as the Co-Optimization of Fuels and Engines effort), and the future ChemCatBio Industrial Advisory Board to identify such opportunities.

The TEA activities within this project will also be utilized to perform a wide-ranging analysis that considers both the volume and the value of potential fuel compounds and additives that can be produced via the various process routes within the project, both individually and as a broader suite of compounds. This will be a central theme of the FY 2018 go/no-go deliverable, which can be used as a mid-project focusing mechanism for the second half of this project. In conjunction with this, we intend to utilize the opportunities within ChemCatBio’s future industrial engagement mechanisms to guide project direction and focus efforts on the R&D approaches and pathways of greatest relevance to industrial stakeholders.

As initial TEAs around these process routes are developed, opportunities to reduce process complexity and increase process intensification will be identified, using sensitivity analysis to identify the most economically impactful opportunities. Additionally, the TEA activities in this project will leverage and utilize rigorous integrated biochemical deconstruction and biological upgrading modeling modules that are already available within the BETO portfolio, coupled with appropriate catalytic upgrading modeling methodologies for the upgrading routes being developed in this project.

ONE-STEP HIGH-YIELD PRODUCTION OF FUNGIBLE GASOLINE, DIESEL, AND JET FUEL BLEND-STOCKS FROM ETHANOL WITHOUT ADDED HYDROGEN

(WBS#: 2.3.1.201)

Project Description

Most fuel ethanol is currently produced from starch in the United States and cane sugar in Brazil, and new technologies are emerging for producing ethanol from cellulosic biomass, such as wood, grasses, and agricultural and forestry residues. However, U.S. ethanol is used primarily as 10% blends with gasoline, and current U.S. ethanol production has virtually saturated that market. The resulting “blend wall” and limited infrastructure to supply or use higher ethanol levels inhibits expansion of bioethanol production. Vertimass, LLC, through an exclusive license from Oak Ridge National Laboratory, seeks to commercialize novel catalyst technology to convert

Recipient:	Vertimass LLC
Principal Investigator:	John Hannon
Project Dates:	5/15/2015–5/14/2017
Project Category:	Ongoing
Project Type:	FY 2014—Biological and Chemical Upgrading: DE-FOA-0001085
Total DOE Funding:	\$1,600,000
DOE Funding FY 2015:	\$1,450,000
DOE Funding FY 2016:	\$1,232,500
DOE Funding FY 2017:	\$1,232,500

ethanol into diesel fuel, gasoline, and jet fuel blendstocks compatible with the current transportation fuel infrastructure. The blendstocks produced are anticipated to fall under the Renewable Fuel Standard at the same level as feedstock ethanol. The catalytic process benefits from (1) production of minimal amounts of light components, (2) relatively mild temperatures and pressures, (3) the ability to process 5% to 100% inlet ethanol concentrations, (4) product flexibility to respond to changing market demands, and (5) no need to add hydrogen. In this project,

Weighted Project Score: 7.7

Weighting: For ongoing projects, there is equal weighting across all four evaluation criteria: Approach, Relevance, Accomplishments and Progress, and Future Work.

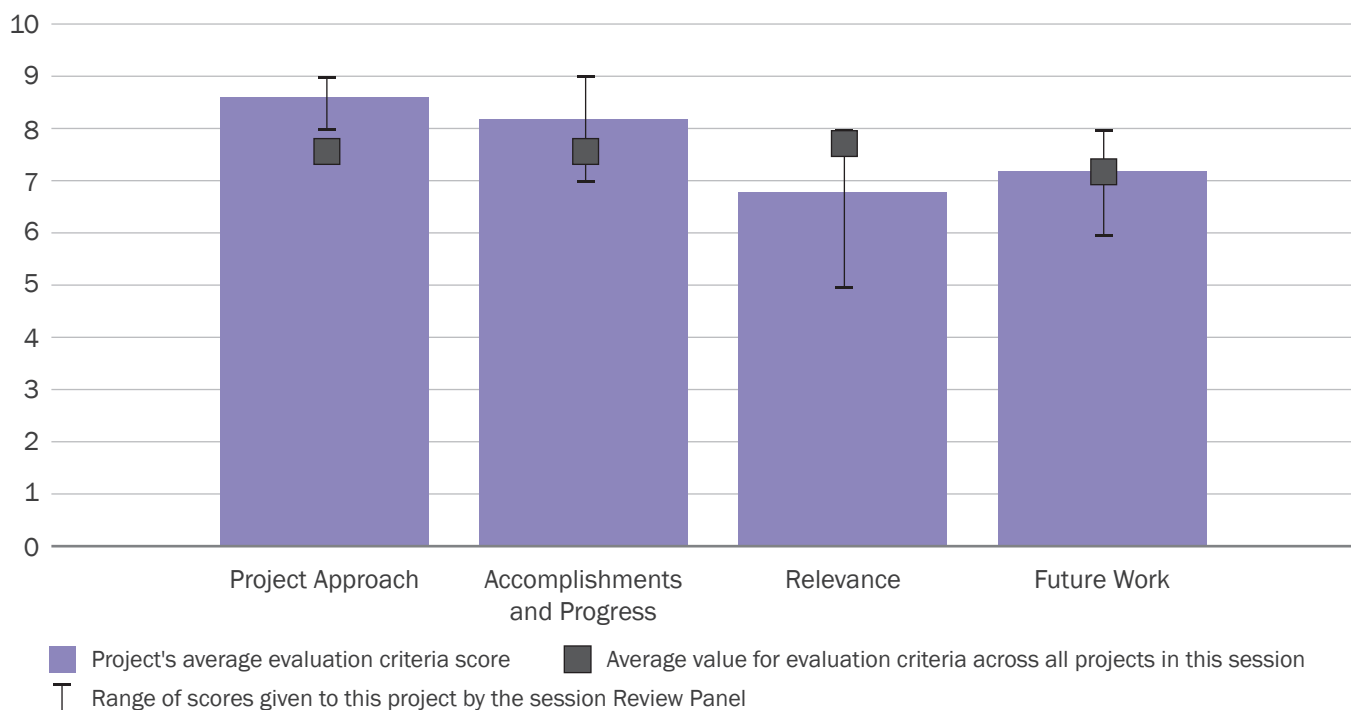



Vertimass has taken major steps in advancing this technology to date, including (1) scaling up the process 150x, (2) maintaining 100% conversion yields of ethanol, (3) increasing liquid yield product distribution from 36% to 83%, (4) moving from powder to pelletized catalyst form, and (5) running ethanol feedstocks with no dilution. The technology advances through Phase 1 of this project have enabled economic feasibility of the Vertimass bolt-on for industrial application.

Commercialization of this novel technology would overcome fungibility issues that limit ethanol use in gasoline for light-duty vehicles and open up new markets for ethanol for heavy-duty vehicles and aircraft. Vertimass plans to partner with ethanol producers—with particular emphasis on emerging cellulosic ethanol plants—as rapidly as possible to overcome the blend wall and also to allow airlines to achieve U.S. Federal Aviation Administration targets of 1 billion gallons of renewable aviation fuel by 2018. This technology would expand opportunities to use more sustainable fuels in the United States. BETO funding will accelerate the scale-up of this technology to realize the important goals of reduced greenhouse gas emissions, enhanced energy security, and domestic jobs.

Overall Impressions

- This is excellent work by the team and a nice fit with ethanol producers to make additional money on chemicals, but this no longer fits with the BETO goal of the fuel program. Also, from past experience, chemical value is questionable for production at ethanol site, which still means it has to go to a fuel/chemical producer mega-plant for isomerization to higher p-xylene fraction to maximize value. Transport and handling of benzene-containing materials is challenging to permit and, as such, would require numerous plants in the future producing ethanol at a smaller scale. Thus, what is an interesting proposition can become a benzene-production nightmare across the entire United States if implemented at numerous plants. This concern needs to be addressed quickly if ethanol producers are to be advantaged by this extra production of BTEX (benzene, toluene, ethylbenzene, xylenes) for value.

Capital and operating expenses for this technology are also an issue as the plant must have a business case that justifies upgrading to BTEX versus selling product as ethanol. Return on investment is a key concern in the long run for the corn producers. It is yet to be seen if this can add value on top of cellulosic, as there is no Renewable Identification Number (RIN) credit for BTEX.

- The project is well-run, and the results are very positive. It is likely that the ethanol conversion process could be commercialized, depending on the price.

This project anticipates that there will be a surplus of ethanol in the near future, and the RINs will not be available. It is prudent to develop a hedge against this time. However, the assumption that this can be a quick add-on to an ethanol plant is not viable because the products include aromatics, which will greatly affect the Occupational Safety and Health Administration and U.S. Environmental Protection Agency burden on the plants.

- This is a nice project that helps solve the issue of excess ethanol caused by the “blending wall” by converting it into fuels and chemicals. The project shows good progress and is well-managed, including relevant partners.
- Overall, this is a very interesting and timely project given the parallel developments happening in ethanol to olefins. Efficient conversion of ethanol into hydrocarbons has the potential to dramatically change the conversation regarding ethanol’s importance in the chemical supply chain. This would not only affect corn and cellulosic ethanol, but also the coal-based ethanol that could come online in the future. As far as this project is concerned, yields have been improved, scale has been increased, multiple ethanol concentrations have been tested, and the process does not require hydrogen. Overall, this project’s accomplishments and progress have been very impressive. Some future work around mixed alcohol feeds, or other even mixed volatile fatty acid feeds, could expand utility and options.

- This is a very promising project with team dedicated to technology commercialization. It is a good use of DOE funding to accelerate development and commercialization of ethanol conversion technology.

PI Response to Reviewer Comments

- We are engaging industrial contacts regarding both our gasoline-like main product and chemical (BTEX) co-product values and how they can be incorporated into existing refining infrastructure. Our main product still is a fuel, and the BTEX is intended as a co-product to offset operating expenses.

The ethanol producers will have the flexibility to partially or fully produce Vertimass products (gasoline-like fuel and concentrated BTEX) or continue to make ethanol to take advantage of market conditions and maximize their revenue. We anticipate the ethanol RINs will transfer into our fuel product, supporting higher prices. However, the ethanol RINs do not currently transfer into the BTEX product, but these BTEX products command a price premium over fuels, so this is partially hedged.

CATALYTIC PROCESSES FOR PRODUCTION OF α , ω -DIOLS FROM LIGNOCELLULOSIC BIOMASS

(WBS#: 2.3.1.204)

Project Description

This project is developing a multi-step catalytic approach for converting biomass into 1,6-hexanediol and 1,5-pentanediol. These α,ω -diols are high-volume (2.6 million tons/year), high-value (\$2,000–\$4,600/ton) commodity chemicals used in the production of polyurethanes, coatings, acrylates, adhesives, polyesters, and plasticizers. The biomass is first converted into furfural, lignin, and cellulose. The cellulose is then converted into levoglucosan, which is dehydrated into levoglucosenone (LGO) in the condensed phase with dilute acid using a polar, aprotic solvent. The product selectivity is a function of the water concentration, the solvent type, and the cellulose loading. Increasing the water content

Recipient:	University of Wisconsin
Principal Investigator:	George Huber
Project Dates:	2/1/2015–1/31/2018
Project Category:	Ongoing
Project Type:	FY 2014—Biological and Chemical Upgrading: DE-FOA-0001085
Total DOE Funding:	\$2,957,576

in the solvent leads to the production of 5-hydroxymethylfurfural. The LGO is then hydrogenated into dihydrolevoglucosenone, levoglucosan, and tetrahydropyran-2-methanol. The tetrahydropyran-2-methanol then undergoes selective C-O-C hydrogenolysis to produce 1,6-hexanediol using a bifunctional catalyst with more than 90% selectivity to 1,6-hexanediol. The furfural then undergoes a series of reactions to produce 1,5-pentanediol. We will describe the catalytic chemistry that happens in each of these steps and estimate the economic viability of our approach to produce infrastructure-compatible biomass based commodity chemicals.

Weighted Project Score: 7.6

Weighting: For ongoing projects, there is equal weighting across all four evaluation criteria: Approach, Relevance, Accomplishments and Progress, and Future Work.

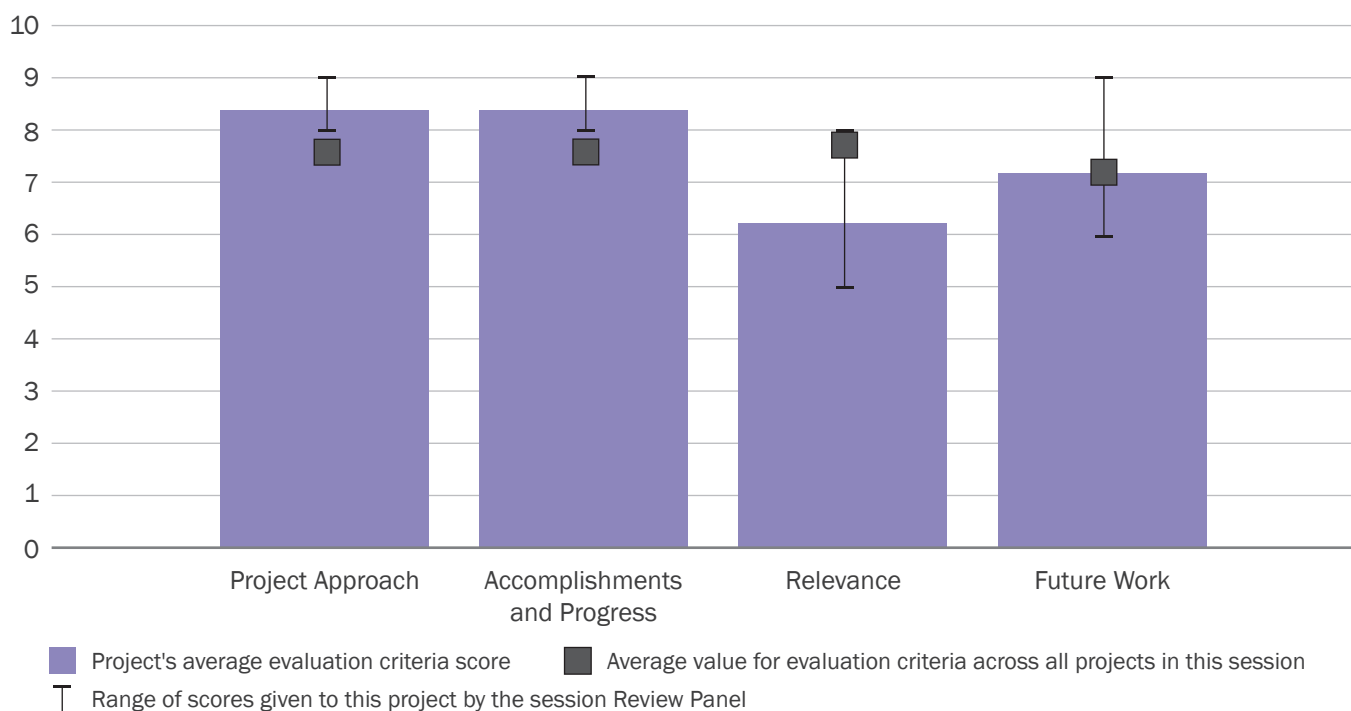

Overall Impressions

- The work was high quality as always by George, with clear goals and solid achievements. Economics appears more challenging than presented, considering the number of process steps and use of large amounts of solvent to recycle. If possible, in the final project year it would be useful to prove out conversion of 1,6-hexanediol to a commercial polymer to compare side by side to the current petrol-produced material.
- This project is more appropriate for a startup company with the goal of producing the diols rather than as an add-on to a biofuel project. The complexity of the project suggests it will take many years to completely develop. Does BETO have the resources to be ready to commit for the long term? The value of the diols produced is limited by the global market needs. Only 2–3 plants would fill this need. It is unclear whether the amount of fuel co-produced by the technology would significantly progress BETO's mission to use 1 billion tons of biomass for energy.
- This is an interesting alternative process scheme for production of valuable chemicals from biomass. It's still to be seen if the technology can attract commercial interest from industry. The process scheme appears very complex.
- Overall, this is an impressive and compelling project. The team has shown considerable levels of innovation and adaptability as more has been learned about these conversions. Consideration of alternative C6 products with better yields, such as LGO, cyrene, tetrahydrofuran-dimethanol, and 1,2,6-hexanetriol is interesting. Chemical conversions are well thought out, and experimental results mostly show conversion efficiencies that can be worked with. There is a high probability that this work will contribute to important new developments in the field, but economics should first be grounded in facilities purchasing commercially available raw

materials, like furfural and cellulose, before making the leap to mega-scale biorefinery integrations that could potentially collapse the market for some of these specialty, niche chemicals.

- This was a good overall discussion of an interesting technology option for biomass valorization. However, feed molecule substitution in the polymer area is tough. Unless the technology provides tangible benefits (cost!) compared to existing processes, it is difficult to see a scenario in which pentanediol demand will be sufficient to justify investment. Hexanediol is used in substantial amounts so market penetration has a higher likelihood of success.

PI Response to Reviewer Comments

- We thank the reviewers for their comments and analysis of this project. We are legally constrained to follow the guidelines put forth in the FOA for this project. The FOA requires starting with lignocellulosic biomass. Therefore, we focused our analysis on technology for the conversion of lignocellulosic biomass into 1,5-pentanediol and 1,6-hexanediol. As described in our presentation a plant that produces 43 kilotons (kt) α,ω -diols/year from white birch costs \$810 million. We also agree that a process that converts lignocellulosic biomass into α,ω -diols has too many process steps to make economic viability right now. However, as described in our presentation, this technology could economically convert furfural into 1,5-pentanediol with a low capital cost and only three steps. We estimate that a plant that produces 37 kt 1,5 pentanediol per year would have a capital cost of \$50 million.

Each of the three steps for the conversion of furfural into 1,5-pentanediol has been done in continuous flow reactors in our laboratory with hundreds of hours of time on stream. Based on our rigorous economic analysis and assuming an internal rate of return of 10%, the minimum selling price of 1,5-pentanediol from furfural ranges from \$1,300–\$3,000

per ton. We agree that a biorefinery that focuses on conversion of lignocellulosic biomass into α,ω -diols would take years to completely develop. However, a biorefinery that takes furfural and converts it into 1,5-pentanediol is simpler and would take less time and resources to develop. The same is true for a biorefinery that converts cellulose into some of the other oxygenated molecules we produce in our approach.

One of the reviewers claims that only 2–3 plants would fill the need for α,ω -diols. This is not correct. The current production of 1,4-butanediol and 1,6-hexanediol is 2,500 and 138 kt/year, respectively. These markets are growing at over 5% year. Therefore, the annual growth of the diols market volume is about 130 kt. Thus, if our technology was to become the low-cost producer of α,ω -diols and capture the growth of this market, then 2–3 plants would have to be built each year.

The scope of this project is to develop and commercialize new technology for biomass conversion, which is a feedstock that has inherent disadvantages, such as low energy density and the presence of solids, compared with fossil fuels. Based on the financial reality, we think the prices of α,ω -diols are high enough to represent reasonable commercial targets. There are no high-price and large-volume

materials. Targeting a larger market volume leads to a lower price that would seriously threaten commercial viability. Thus, to attain a large-volume and low-price commoditized market is extremely high risk.

Another reviewer stated that “it would be useful to prove out conversion of 1,6-hexanediol to a commercial polymer to compare side by side to the current petrol-produced material.” We agree this is an important goal in the technology development pathway. Unfortunately, the legal rules of the current FOA do not allow us to do this type of research with this funding. We are in the process of trying to obtain funding to do this important research step. We also agree that this technology has the potential to produce other niche chemicals like LGO, cyrene, tetrahydrofuran-dimethanol, and 1,2,6-hexanetriol and are studying ways we can produce these products more efficiently.

We would like to thank the reviewers for their time in reviewing this project. We would also like to thank DOE for supporting this research. In this project, we are studying and demonstrating new catalytic chemistry that has previously been unexplored. We think this project will lead to new commercial technologies for biomass conversion into commodity chemicals. We will continue to discuss our technology with interested industrial partners.

FAST PYROLYSIS AND UPGRADING

(WBS#: 2.3.1.301-2)

Project Description

The project objective is to advance the technology for converting liquid transportation fuel from biomass via pyrolysis and catalytic upgrading. This will be accomplished by techno-economic analysis (TEA)—targeted research to drive the technology toward targets established in the 2016 Multi-Year Program Plan. The approach combines understanding of chemistry, catalyst, and process development for improved efficiency and economy, guided and measured by TEA, stakeholder involvement, and demonstration of the technology at scale. This project addresses the major challenges associated with fast pyrolysis bio-oil upgrading, including the following: (1) bio-oil deep stabilization by hydrogenation enabling bio-oil upgrading via hydrotreating; (2) highly reactive catalyst, contaminant management, and efficient regeneration to significantly enhance stabilization catalyst

Recipient:	Oak Ridge National Laboratory, Pacific Northwest National Laboratory
Principal Investigator:	Jae-Soon Choi
Project Dates:	10/1/2016–9/30/2019
Project Category:	Ongoing
Project Type:	Annual Operating Plan
DOE Funding FY 2014:	\$1,430,000
DOE Funding FY 2015:	\$2,210,000
DOE Funding FY 2016:	\$2,450,000
DOE Funding FY 2017:	\$1,925,787

lifetime; and (3) demonstration at different feedstocks and reactor scales to enhance technology viability.

The project has made continuous improvements to meet BETO's targets for the fast pyrolysis state of technology every year since 2009, targeted and measured by TEA, and is on schedule to meet BETO's 2017 target of \$3.50/gge. It also seeks to enable technology-to-market transformation by demonstrating at scale, contributing

Weighted Project Score: 6.9

Weighting: For ongoing projects, there is equal weighting across all four evaluation criteria: Approach, Relevance, Accomplishments and Progress, and Future Work.

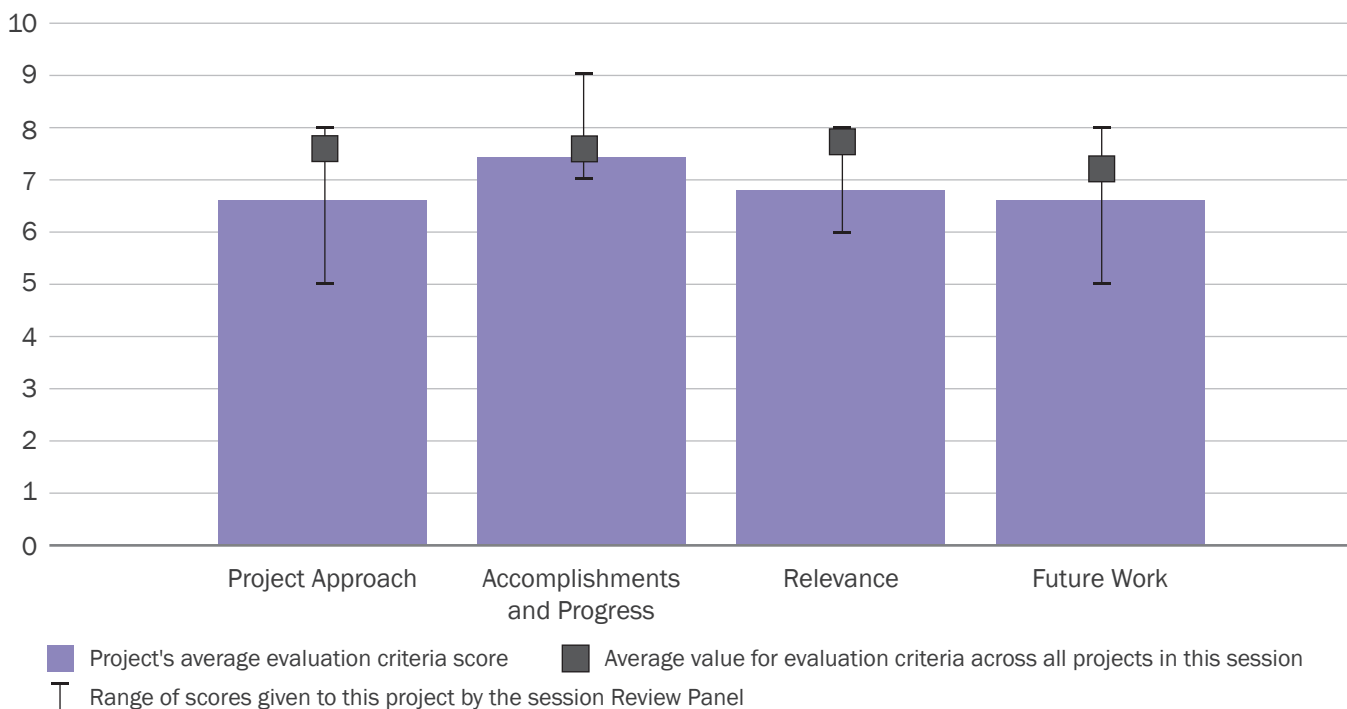

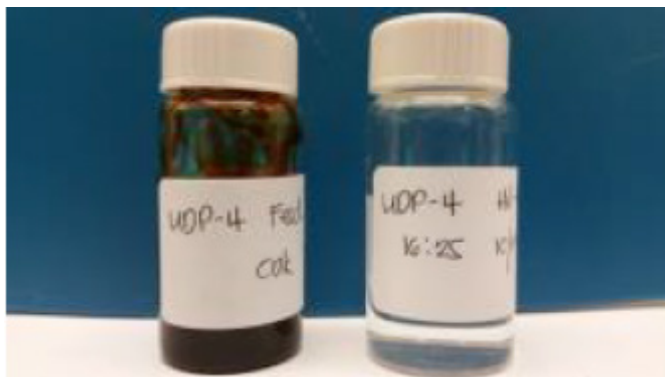

experimental measurements to reactor modeling efforts, and developing technology options based on TEA/ life-cycle analysis and input from stakeholders. Results from this project, including upgrading processes, catalysts, and capabilities, will be leveraged by existing and future BETO-funded efforts.

Overall Impressions

- This is a high-impact, high-quality project that provides useful, realistic information on feedstock supply. It is well-integrated with commercial and sustainability aspects of the BETO portfolio.
- This is excellent work to estimate the potential and growth of the industry.
- This project has presented useful research. However, there needs to be integration with agencies, universities, and industry. The project needs to validate simulations with real data. The project should put more emphasis on the near term (e.g., the next 5 years) and less on the long term (e.g., 15–20 years).
- This project has accomplished a lot with its integrated modeling work; however, these studies seem disjointed and it is not clear if data are available to validate these complex processes.
- This project utilizes best available information from BETO and other biomass logistics projects to conduct a systems analysis of the supply chains and

associated biorefineries. These efforts are closely linked to and support the *BT16* estimations of biomass availability. Technical accomplishments include the prediction of available biomass quantities at varying costs and the resulting number of biorefineries. The assumptions made are obviously overly optimistic, as a projection of 73 biorefineries in 2017 was shown, when we actually have two. Methodologies to benchmark and adjust predictions with current conditions should be considered.

The work presented and the future activities effectively utilize expertise in the national laboratories, particularly Oak Ridge National Laboratory and INL. The planned work on modeling of biomass moisture management should be closely aligned with the efforts at INL to consider the storage and processing of high moisture materials. This project makes valuable contributions to BETO.

- Overall, the project has developed and integrated field drying modeling into the FSL model to manage and monitor the moisture content of delivered feedstock. It is expected that the future work will include additional feedstock quality specifications explicit to a biorefinery for accurately estimating the feedstock cost, while minimizing the feedstock quality risks.

PI Response to Reviewer Comments

- In the last 2 years, the Oak Ridge National Laboratory logistics modeling team have been working with their industrial partners to collect field data such as equipment speed, fuel consumption, bale bulk density, and harvest moisture content, etc. These models currently have updated input data. New harvest data were collected from biomass producers, aggregators, and equipment manufacturers (i.e., local farmers, State University of New York harvest team in New York and Oregon, Antares, Pacific Ag, and AGCO Corporation).

LIQUID FUELS VIA UPGRADING OF INDIRECT LIQUEFACTION INTERMEDIATES

(WBS#: 2.3.1.304-5)

Project Description

This project seeks to develop a responsive, integrated biorefinery concept based on indirect liquefaction technologies that (1) produces a suite of fuels and co-products and (2) provides control over the product distribution such that process operation can be adjusted to meet increasing distillate fuel market demand. Advanced upgrading technologies from syngas are critically needed for the successful commercial implementation of fuel production at a scale relevant for biomass. Research tasks leverage light oxygenate intermediates from syngas and focus on the development of new catalytic pathways with lower severity conditions to achieve high-carbon yields of gasoline, diesel, and jet fuel with integrated routes to co-products that

Recipient:	Pacific Northwest National Laboratory, National Renewable Energy Laboratory
Principal Investigator:	Rob Dagle
Project Dates:	10/1/2016–9/30/2019
Project Category:	Ongoing
Project Type:	Annual Operating Plan
DOE Funding FY 2014:	\$3,258,000
DOE Funding FY 2015:	\$3,750,000
DOE Funding FY 2016:	\$3,750,486
DOE Funding FY 2017:	\$3,600,000

can improve overall economics. Each pathway under investigation offers promise to generate high-quality fuels (e.g., high-octane gasoline with low aromatics, desirable jet- and diesel-range hydrocarbons) and to achieve favorable cost targets by 2022. Recent catalyst and process-development accomplishments are shown in the 2x–3x productivity increase in two of the pathways under investigation. By the end of FY 2019, this project will develop a new indirect liquefaction process

Weighted Project Score: 7.8

Weighting: For ongoing projects, there is equal weighting across all four evaluation criteria: Approach, Relevance, Accomplishments and Progress, and Future Work.

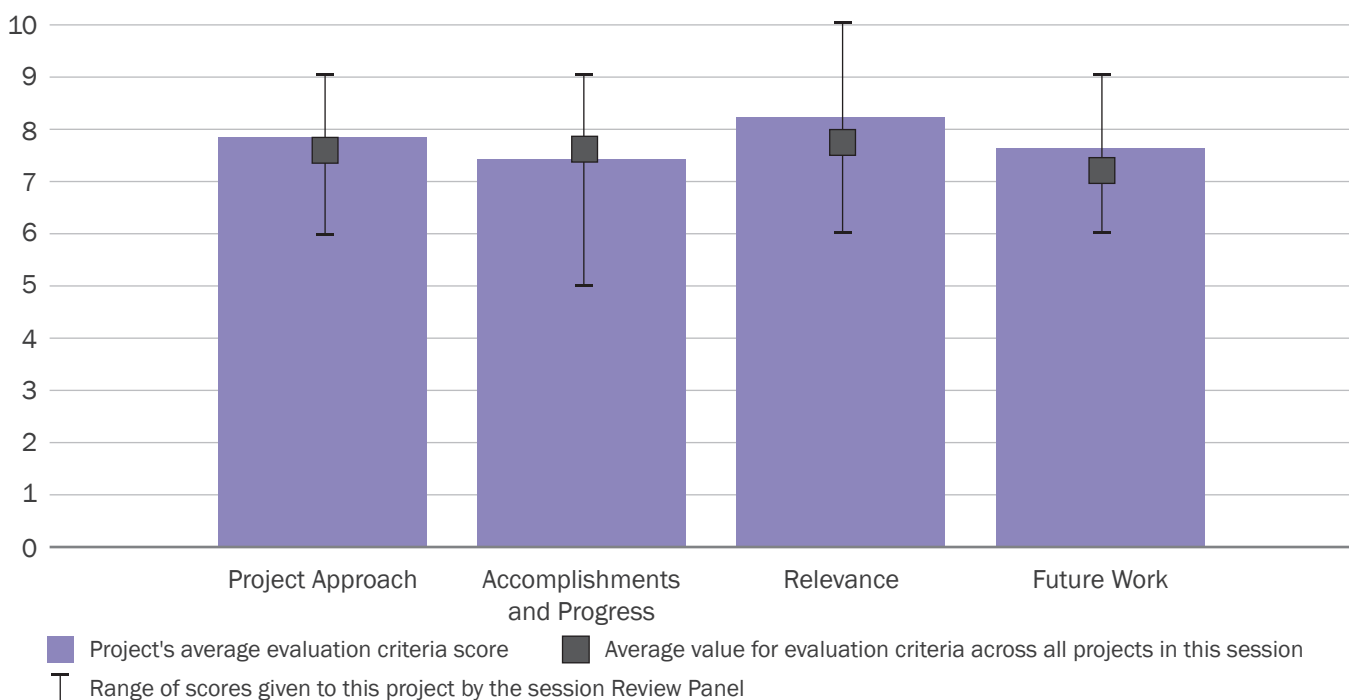

for distillate fuel production for verification in FY 2022. This new process will exceed the distillate fuel product yield of 27.4 gge/dry ton biomass of the benchmark Mobil olefin-to-gasoline/distillate process.

Overall Impressions

- Team results are impressive and commendable. The team has well-planned approaches and excellent organizational structure to maximize results, from modeling to catalyst development to improvements since last review. One question I may have not seen an answer to is carbon efficiency for the various processes. I did see gge cost clearly identified and highlighted for Task 1. Is this in progress for Task 2?
- The project promotes alternatives to the Fischer-Tropsch process for the conversion of syngas via light oxygenates. These alternative routes are currently too expensive to be competitive with other routes for the production of lower-quality fuels. However, the team has found target markets that take advantage of the high-octane and other properties of the feed that provide more venues.

It may be difficult to select between the alternative processes in the time available. Catalyst life, regenerability, and process complexity should be factors in the selection process.

The use of an Rh catalyst should be avoided; however, the team responded that they were already moving away from rhodium.

Direct conversion of bio-syngas to light olefins would be the most attractive route. The Ni-Co catalysts are being developed by a number of groups as the next wave of Fischer-Tropsch catalysts. Showing that this type of catalyst and process conditions can be adjusted to produce olefins from real biomass would be a major leap forward.

- This is an interesting project that will develop new

and maybe more economical ways to produce fuel from syngas rather than the current Fischer-Tropsch and methanol-to-gasoline technologies. It is important for the project team to stay focused and not get distracted by the multiple options for fuel flexibility and co-products. Co-products in a biorefinery may add value, but they also add complexity, as well as uncertainties for the future profitability of the biorefinery if the co-product value decreases.

- Overall, there are promising developments and a good perspective on how to address challenges. The program is working to reduce process intensity and is targeting higher-value fuels. To some extent, this is being done by using product octane content as a standard or measure, and this is a great idea. Fewer separations, less H₂ utilization, and close work with the fuel/engine teams is a recipe for success that will support commercial relevance.
- The technical approaches described in this project presentation were sound. The technical work performed in the prior budget period was described in detail, and the results were impressive, so I'm willing to grant some leeway. But, the FY 2017 project plan lacked detail that would have been helpful in project evaluation.

PI Response to Reviewer Comments

- We appreciate the reviewers' positive remarks about the project results, approach to target high-value fuels, organizational structure, and incorporation of enabling technologies and researchers with fuel property expertise.

We appreciate the reviewers' encouragement to stay focused and not get distracted in too many directions. This is reflected in our 2018 go/no-go milestone, where a single pathway will be selected for detailed development and verification in 2022, and we understand that the 2018 go/no-go is an ambitious goal. We appreciate the suggestion of addition-

al factors, such as catalyst life, regenerability, and process complexity to aid in the decision. We note that we have begun to address some of these issues with extended operation and regenerability demonstration for both the copper/zeolite beta polymorph (100 hours) and the Guerbet ethanol coupling catalyst (500 hours). Also, process complexity is certainly a major concern and is incorporated in the techno-economic analyses. We will certainly incorporate these factors in the selection processes. The reviewers' comments about co-product value and, importantly, fluctuations in value are well put and appreciated.

We agree that the use of an Rh catalyst may not enable cost-effective production of commodity chemicals. This is one reason why we have shifted away from the use of the Rh mixed oxygenate catalyst to other more promising pathways.

With sustained funding, we will continue to develop the direct pathway from syngas to light olefins over Ni-Co catalyst (Task 3), and we agree that success in this area represents a major leap forward for syngas conversion specifically. We do note that while this pathway offers tremendous potential, there are major challenges as well that need to be overcome, particularly with respect to carbon efficiency. Thus, we consider this a high-risk but high-reward pathway. We plan to continue to develop this route given adequate resources.

We did not highlight carbon efficiency for the processes during the presentation, but rather, focused on the technical accomplishments that feed into that

calculation and the resulting MFSP versus mature industry comparisons (e.g., Fischer-Tropsch, Mobil olefin-to-gasoline/distillate). For example, in Task 1, moving from the parent zeolite H-beta polymorph catalyst to the National Renewable Energy Laboratory's copper/zeolite beta polymorph catalyst results in an increase in C efficiency to C5+ product from 20.8% to 31.0%, which nearly reaches the maximum in this design case of 31.2%. For both Task 2 ethanol conversion pathways (i.e., butadiene and Guerbet), we project carbon efficiency to a final distillate to be >70% from ethanol. Note that this does not take into account carbon efficiency prior to the ethanol production. Due to time constraints, we were not able to highlight the overall processing pathways (which includes oligomerization of produced olefins, etc.). Also, techno-economics using recent data are being fed into models for determining overall performance and cost assessments. Overall, carbon efficiency is certainly one of the most important factors in assessing processing effectiveness.

We apologize that the future project plan was not presented in sufficient detail for one reviewer. To elaborate here, our FY 2017 plan is the initial year targeting distillate fuels. We will set the state-of-technology and initial techno-economic analysis models for the processes based on initial technical accomplishments. Also, we will complete our previous effort that focused on gasoline production through an integrated verification from biomass to hydrocarbon fuels, targeting 300 hours of continuous operation.

ELECTROCHEMICAL METHODS FOR UPGRADING PYROLYSIS OILS

(WBS#: 2.3.1.307-9)

Project Description

This project has sought to develop an electrochemical processing method to upgrade biomass materials and waste streams. Electrochemical upgrading of bio-oil is a potential substitute for hydrothermal stabilization processing where several upgrading functions are possible in a single step: partial hydrogenation without adding elemental hydrogen, total acid number reduction and separation, and recovery of carboxylic acids. Starting as a lab-directed seed project, work over 3 years has focused on achieving a process to economically stabilize bio-oil. A phased approach to development involved advancement in several tasks: processing with a single membrane cell, anion exchange membrane development, acid separation cell testing, theoretical modeling/experimental assessment, and techno-economic analy-

Recipient:	Idaho National Laboratory, Pacific Northwest National Laboratory, Argonne National Laboratory
Principal Investigator:	Tedd Lister
Project Dates:	10/1/2015–9/30/2016
Project Category:	Sun-setting
Project Type:	Annual Operating Plan
DOE Funding FY 2014:	\$815,000
DOE Funding FY 2015:	\$825,000
DOE Funding FY 2016:	\$935,000
DOE Funding FY 2017:	\$0

ses. In the last year, the team integrated knowledge from these tasks into developing a dual-membrane electrochemical cell, which possesses the ability to reduce bio-oil and separate bio-oil. While the goals of the project were not fully realized, the project has made significant strides in understanding the issues and technological challenges ahead for using electrochemistry to upgrade bio-oil. The project identified a promising path using the dual membrane system that significantly increased pH,

Weighted Project Score: 5.8

Weighting: Approach–25%; Relevance–25%; Accomplishments and Progress–50%.

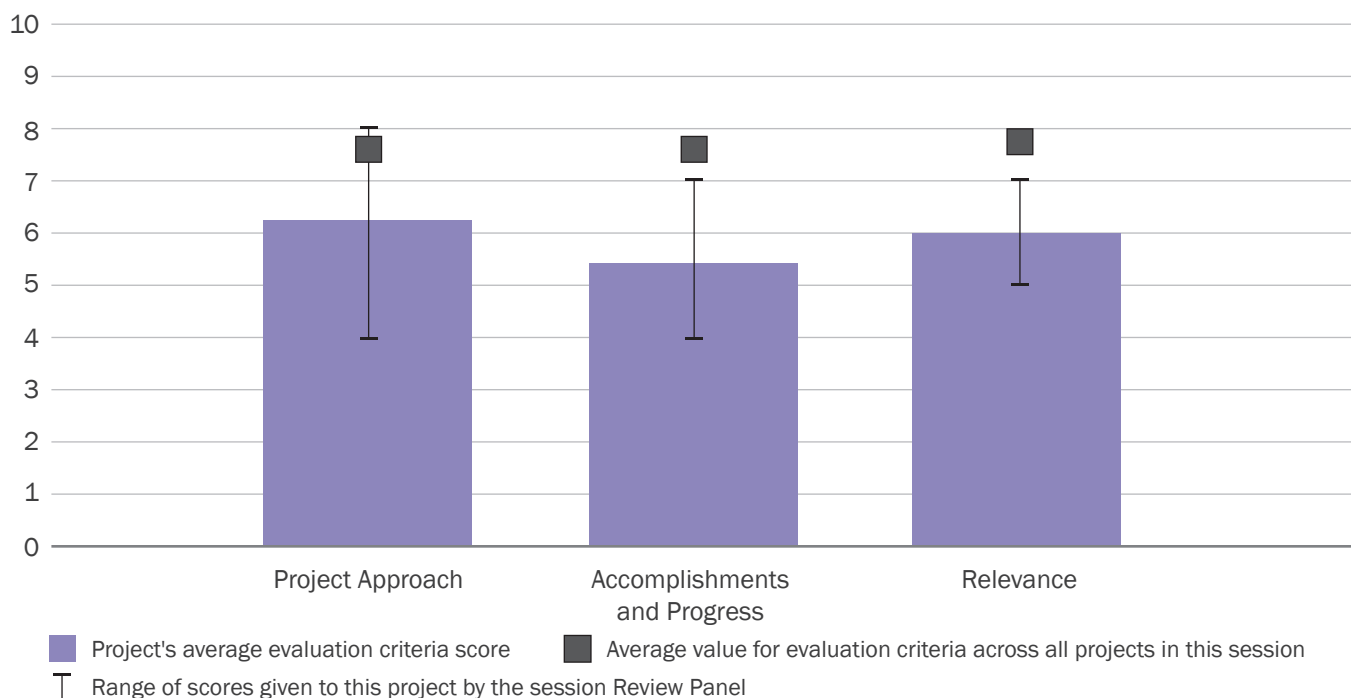

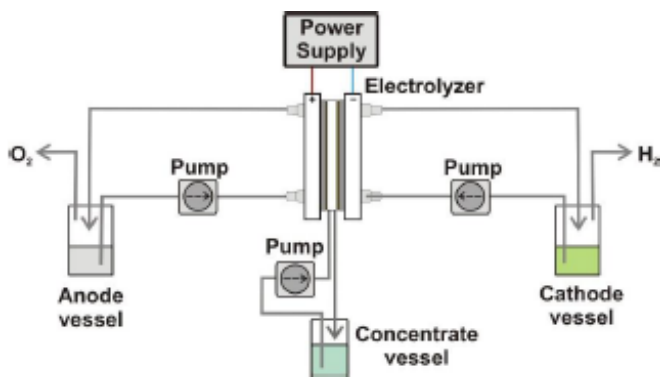

removed organic acids, and showed modest carbonyl reduction.

Overall Impressions

- This was a novel and interesting approach, but the hurdles and challenges were far too great to have the ability to provide a route for stabilization of fast pyrolysis oils. I am still happy that BETO is exploring some unique and novel approaches along with the standard ones. Keep looking to unique breakthrough approaches, even though this one was not successful.
- This was a good attempt to employ a new technology to biomass upgrading. I am unsure that storing renewable energy as hydrocarbons will ever be able to beat the rapidly developing battery technology. I believe that the separation applications have more promise as a method for water purification or pulling out highly polar species from the bio-oil phase. Distillation of biomass products is very difficult, and alternatives are needed.
- The project investigated an interesting alternative route for biofuel upgrading. Several challenges were

identified. The project has not resulted in an optimal solution.

- Overall, this is an interesting project. An important issue is that the standard of measure is H₂ hydrogenation, which will almost certainly never be a commercial reality at any significant scale. It is also widely accepted that water hydrolysis is a more expensive way to generate H₂ at scale than steam reforming. However, it is likely that this technology would have more utility as a form of low-pressure membrane concentration for other waste streams containing a high level of acid or ionic components.
- This was an interesting approach to pyrolysis oil stabilization and worth investigation. Technical results were promising. I still want to know whether or not the EC-treated oil showed enhanced stability and particularly improved lifetime in hydrodeoxygenation (or other upgrading approaches) to hydrocarbon fuels.

PI Response to Reviewer Comments

- A final thank you to the reviewers for your comments—I feel this was a very constructive experience. While battery technology is a viable option, fuels from biomass leverage significant combustion technology and infrastructure that batteries will struggle to match. Moving forward with all viable options is the best path. Clearly, we did not perform to the level we had hoped. However, we do feel that there are some very positive results coming from the work performed. Given that we were venturing into unknown terrain, there was always a risk to delivering a scale-up ready process.

RECOVERING AND UPGRADING BIOGENIC CARBON IN BIO-MASS-DERIVED AQUEOUS STREAMS

(WBS#: 2.3.1.310-1)

Project Description

Biomass direct liquefaction processes (e.g., hydrothermal liquefaction [HTL], catalytic fast pyrolysis, or fast pyrolysis) produce aqueous phases during bio-oil generation and/or subsequent hydrotreating. The objective of this project is to enhance the economic viability of converting biomass to fuel by converting “waste” aqueous-phase organic compounds to value-added chemicals or fuels while reducing wastewater treatment costs, which can be considerable, especially for phenolic rich streams. Pacific Northwest National Laboratory and the National Renewable Energy Laboratory are developing complementary thermocatalytic and separation processes,

Recipient:	Pacific Northwest National Laboratory, National Renewable Energy Laboratory
Principal Investigator:	Karl Albrecht
Project Dates:	10/1/2016–9/30/2019
Project Category:	Ongoing
Project Type:	Annual Operating Plan
DOE Funding FY 2014:	\$1,925,000
DOE Funding FY 2015:	\$1,900,000
DOE Funding FY 2016:	\$1,910,200
DOE Funding FY 2017:	\$1,750,000

es, each with advantages and disadvantages depending upon the types and concentrations of organics present.

Pacific Northwest National Laboratory developed a LaxZryOz catalyst with excellent stability in condensed water, with demonstrated stable ketonization activity for thousands of hours. A \$0.30/gge modeled decrease in MFSP for HTL was demonstrated by converting aqueous acids to olefins. Pacific Northwest National Laboratory

Weighted Project Score: 7.3

Weighting: For ongoing projects, there is equal weighting across all four evaluation criteria: Approach, Relevance, Accomplishments and Progress, and Future Work.

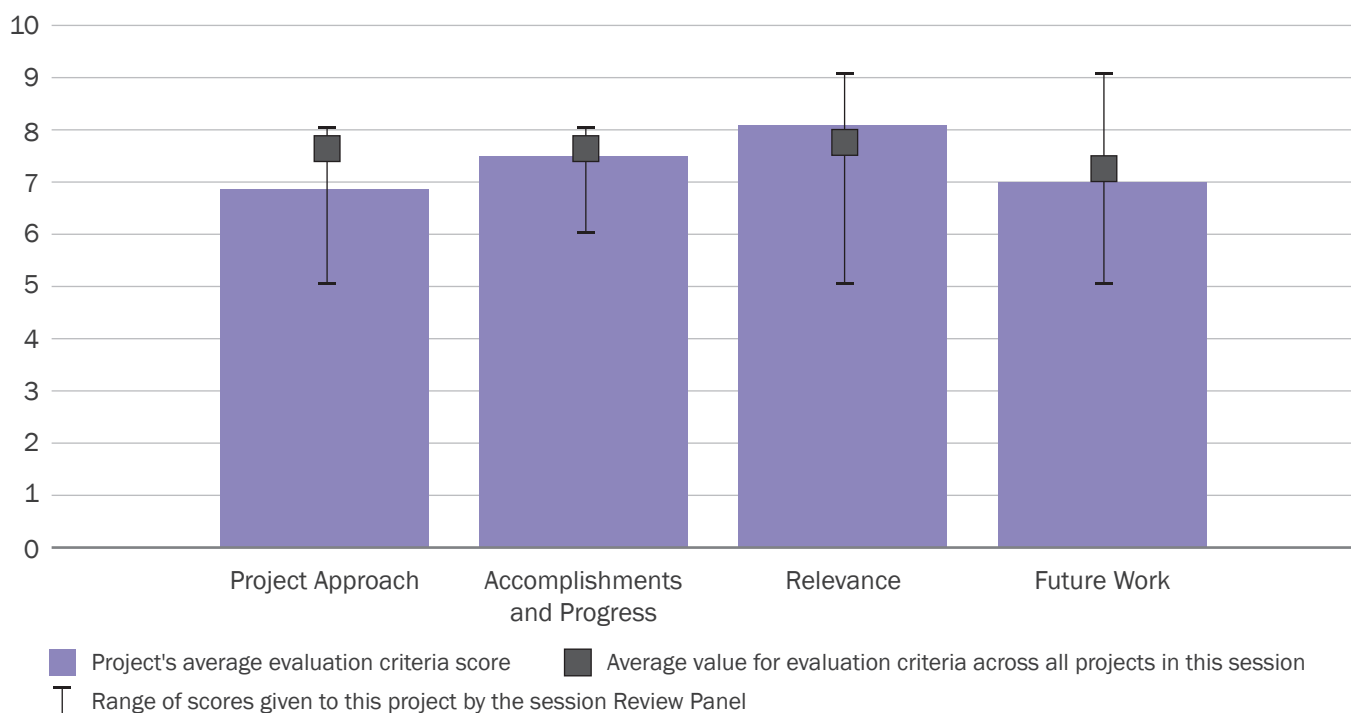

Goals for SOT experiments

- Assess **yield and selectivity** of conversion to **BTX**
- Compare **best** catalysts (HZSM-5 and Ga/HZSM-5)

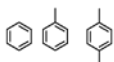

Aqueous phase from catalytic fast pyrolysis*

Carbon: 13.8 wt%
Hydrogen: 8.1 wt%
Water: 67 wt%

Composition of CFP Aqueous Phase*

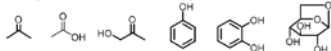

Contain some unreacted pyrolysis products

tory also developed a new dual-bed ketonization-steam reforming process that converts HTL-derived acid-rich feedstock to H_2 . An H_2 yield of 96% was demonstrated and with 4x less coke on the catalyst than when using steam methane reforming catalyst alone. Complimentary gas-phase technologies to produce fuels (aromatics) and chemicals (furans) with zeolitic and amorphous Si-Al are also under development at the National Renewable Energy Laboratory. A process for converting catalytic fast pyrolysis-derived aqueous product to aromatics was developed that is projected to decrease the MFSP by \$0.20/gge.

Overall Impressions

- The team has done a nice job of laying out the approaches, the key need, and organization. Work results, considering how long the team has been in place, are substantial. The approach via oxidation chemistry of aromatics will be extremely challenging on economics. It may make more sense to convert them to acetate esters for separation and isolation to make other materials, as a suggestion.
- Finding the best methods for recovering carbon from the aqueous product of biomass processing is critical to improving the process economics. Combining the efforts of all of the national laboratories should help accelerate this work and generate new ideas and synergies. The approaches need to be held to a rigorous economic standard to help focus on those most likely to succeed. The development of a comprehensive guide to wastewater treatment from biomass conversion process will be a major help to smaller commercial companies. There are examples

of companies stopped very late in the demonstration process by issues concerning water management.

- The project is an important and valuable part of the BETO portfolio. It is always great to convert “waste” into “valuable co-products.” It will be interesting to follow the developments.
- Overall, these are innovative ideas and some interesting potential developments. However, there are serious scale-up issues with the quest for complete carbon utilization, and many forest products and agro-industrial processes have faced a similar dilemma regarding how to address their wastewater. Many of these challenges are not new and have been studied and focused on for decades, often with the same results—local/onsite wastewater treatment plant or onsite anaerobic digestion. It is important to focus efforts on waste streams that have species or concentrations that can justify the expense of separation and purification. It is better to focus on opportunities where there are naturally occurring thermodynamic advantages, rather than increasing process intensity to valorize dilute waste streams.
- Upgrading of the biomass-derived aqueous phase is a promising approach that could be one technical piece for addressing biomass valorization. While I believe that there are valid approaches that include biomass fractionation, the number of unit operations (with attendant capital costs) will need to be carefully evaluated in detail for overall process economics.

PI Response to Reviewer Comments

- We appreciate the reviewers’ time and dedication to providing useful and implementable comments on our project. Moving forward, we plan to continue to use techno-economic analysis to determine what is economically feasible when converting these potentially lucrative streams into valuable co-products. We will also focus on sharing the results of our research and techno-economic analyses with stakeholders through peer-reviewed publications and presentations. Not all aqueous streams investigated are

candidates for our processes. For example, algal-derived and wastewater-sludge-derived HTL aqueous streams have very low levels of organics and are likely best sent back to the algae pond for nutrient recycle or anaerobic digestion to produce fuel gas. It is important to analyze and consider process streams on a case-by-case basis even as we develop processes that are applicable to a wide variety of chemical functional groups.

Certainly, the minimization of process steps and process intensification must be a focus whenever possible in all chemical process development. As this project inherently proposes to increase process steps in the pursuit of providing greater value, we must be continually cognizant of the trade-offs between higher yield, greater product purity, and sufficient decontamination of feedstocks. The processes we are developing are robust and capable of handling low levels of impurities, e.g., 10–100s of parts per millions of dissolved solids. We believe this project is also well-aligned with the role of the national laboratories to consider the development of higher-risk/higher-reward research that the forest products and agro-chemical industries may not see as immediately viable. These areas often require technological breakthroughs to demonstrate feasi-

bility. This project is working diligently to provide these types of breakthroughs. For example, hydrothermally stable catalysts are needed throughout the bioenergy space and indeed are interesting as catalysts outside bioenergy. As part of the ChemCatBio consortium, we will work to understand the needs and challenges of these industries through our external advisory board. Along the way, we will continue to be open to new suggestions and ideas for these streams. As an example, suggestions provided by the reviewers for the formation of phenyl acetate and using the HTL aqueous stream as a pretreatment stream will be considered.

Finally, we appreciate the comments regarding the need for a guiding document focused on wastewater valorization and disposal throughout the bioenergy community. This is again an area where our work has the potential to impact numerous stakeholders. In order to fill the wastewater disposal guidance gap, we will begin to compile literature and reviews that discuss wastewater disposal as a first step towards the aqueous-phase options task. Publishing a review paper as a lead-in to our anticipated valorization and disposal guiding document is a worthy first step in the pursuit of rapid information dissemination.

CATALYTIC FAST PYROLYSIS (CFP)

(WBS#: 2.3.1.312, 14, 15)

Project Description

Fast pyrolysis of biomass is a promising route for converting lignocellulosic feedstocks into fungible biofuels; however, the resulting bio-oil must be upgraded prior to utilization as a fuel or blendstock. The focus of this project is to improve the fuel quality and stability of bio-oil through catalytic fast pyrolysis (CFP), in which catalytic upgrading is performed in the vapor phase prior to condensation. The major challenge for CFP is to achieve high carbon yields to the desired fuel-range molecules while operating under relatively harsh conditions that are conducive to catalyst deactivation via carbon deposition.

The overarching goal of this project is to develop a market-responsive biorefinery concept based on CFP, which

Recipient:	Pacific Northwest National Laboratory, National Renewable Energy Laboratory
Principal Investigator:	Huamin Wang
Project Dates:	10/1/2016–9/30/2019
Project Category:	Ongoing
Project Type:	Annual Operating Plan
DOE Funding FY 2014:	\$4,635,000
DOE Funding FY 2015:	\$4,090,000
DOE Funding FY 2016:	\$5,985,500
DOE Funding FY 2017:	\$5,230,329

is capable of producing both cost-competitive biofuels and high-value co-products with targeted yields and compositions. To advance the state of technology, this project will demonstrate by 2019 the production of fuel blendstocks (<1 weight percent oxygen) from optimized CFP processes coupled with hydrotreating that achieve an MFSP of less than \$4/gge, with greater than 25% of the fuel in the diesel range. Over the last 2 years, the

Weighted Project Score: 7.0

Weighting: For ongoing projects, there is equal weighting across all four evaluation criteria: Approach, Relevance, Accomplishments and Progress, and Future Work.

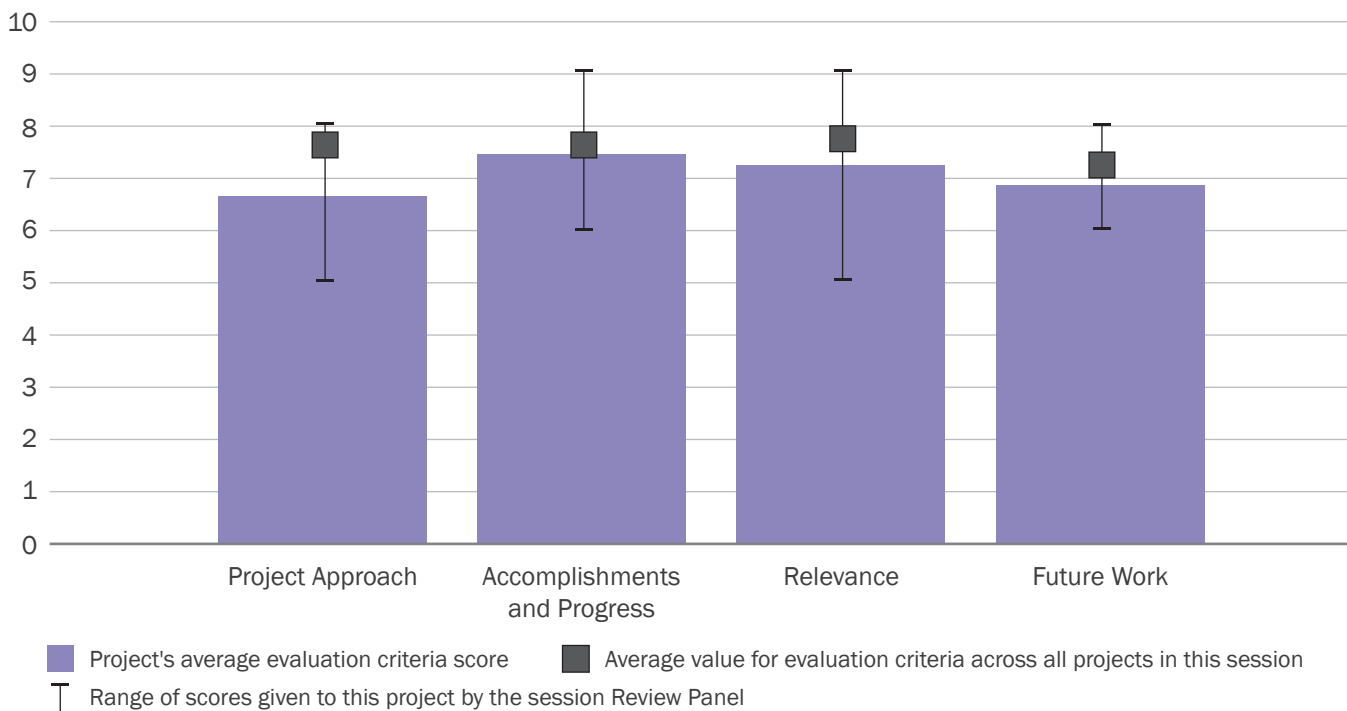

carbon efficiency for the process has been improved from 23% to 28%, resulting in a reduction in MFSP of over \$1.40/gge.

Overall Impressions

- The team has done a great job of assessing three complex approaches to date using solid modeling and solid thinking on what are key factors to address in all three process approaches. It is challenging to say if fast pyrolysis will meet future needs over other approaches, such as isolation of sugars and lignin approaches. However, I believe both need to continue to be developed towards the goals as it is too early to tell which will be the overall best final solution, and the answer most likely will be that multiple approaches are needed to achieve BETO goals in the long term.

I would like to see broader testing of off-the-shelf catalysts outside the Johnson Matthey catalysts and internal catalyst synthesis work. However, perhaps team has done this already? I do not see any specific flaws in team structure, approaches, or work definition and accomplishments to date, which are solid.

- Major improvements in carbon efficiency are needed to make catalytic pyrolysis a viable route. I support the process scheme changes, like evaluating the fixed-bed scheme. Radical changes are needed.

Targeting stabilization makes sense since it may allow integration with refinery processes. This may require the use of a specialized centralized hydroprocessing facility rather than integration into current unit operations. New process configurations like the fixed-bed reactor are very promising and should be emphasized. Reducing the costs of catalysts is vital. Extending the lifetime of the catalyst may be the most effective route to accomplish this. This may require feed pretreatment to reduce ash and/or finding a market for an equilibrium zeolite catalyst.

Input from the modeling group concerning the effect of reactor design, heat transfer, and feed particle

size and structure could have a significant impact on carbon efficiency.

Of course, substituting a less expensive material is also a good approach, but at high attrition almost any material will be expensive.

I believe the use of red mud is a significant lead. However, red mud itself presents problems with consistency since it is not deliberately produced. Looking at the effect of red mud composition or other natural ores would be an interesting approach.

Current catalyst costs are out of line with any current commercial fuel process. Catalyst costs should be significantly less than 5% of the selling price. Methods for reducing these costs should be investigated, including changes in feed.

Replacement of noble metals, particularly Ru, is necessary. There are no commercial commodity chemical processes using Ru because of its lack of natural abundance, despite its advantage as a catalyst for many reactions.

Attempting to process the lignin and cellulose portions of the biomass in the same thermochemical reactor has not accomplished the original goal of simplifying pretreatment and processing requirements. The cellulosic material decomposes into small molecules at temperatures well below those needed to break apart the lignin. The catalysts have not succeeded in adjusting the activities to balance the activities of two fractions.

- The project is well-managed and well-defined and has shown a steady development. The industrial partnership is important for future market acceptance of the technology by industry.
- Overall, this is a solid project with accomplishments that reflect the hard work and determination of the team. Given the thermodynamic challenges being faced head on by this project, the progress is impressive. However, the narrow focus on hydro-

treating is concerning, even if the source of the hydrogen comes from light gases produced *in situ*. More focus on staged pyrolysis to drive off light O₂ rich gases would be more economic, and more focus on catalytic conversion of biomass fractions (crude fiber and cellulosic ethanol lignin) would lead to narrower product distributions. Additionally, *ex-situ* fixed-bed CFP is a logical solution to addressing the challenges of fast pyrolysis on whole biomass, but it is not a logical solution for leveraging what has been learned about catalytic pyrolyzers. Rather than re-tool the pyrolyzer, these learnings should be focused on more-refined biomass feedstocks that enable the catalytic pyrolyzers to generate products of interest.

- This project is a continuation of approaches that have been attempted for many years. While the technical work done so far is interesting, I do not envision the future work plan as described overcoming the remaining technical and commercial challenges.

PI Response to Reviewer Comments

- We thank the reviewers for their support of our accomplishments, team, and management. We acknowledge that CFP is a complex and challenging process, but it has many distinct advantages. CFP allows for utilization of the entire plant matter and produces a narrower product slate as compared to fast pyrolysis. We greatly appreciate the reviewers' constructive feedback and guidance on how to best advance the state of technology towards commercialization, especially in regard to innovative process configurations, alternative downstream processing, evaluation of off-the-shell catalysts, reductions in catalyst cost, integration with modeling, and utilization of refined or fractionated feedstocks. The reviewers also raised a number of valid concerns, and we have addressed specific comments below.

Feedstock properties definitely affect CFP performance. These effects are currently being evaluated

in the Thermochemical Feedstock Interface project, a joint effort between the National Renewable Energy Laboratory, Pacific Northwest National Laboratory, and Idaho National Laboratory, and will be further evaluated in the future as part of the Feedstock-Conversion Interface Consortium. We have evaluated various biomass fractions for CFP in small-scale experiments (pyrolysis-gas chromatography/pyrolysis-molecular-beam mass spectrometry) to target specific product distributions and will evaluate CFP of these fractions at a larger scale in 2018 using the pyrolyzer–Davison Circulating Riser system. We plan to use these experiments to guide feedstock selection (and feedstock engineering).

We agree that the high catalyst replacement rate for in-situ CFP is a major challenge for that approach. The red mud catalyst under development within this project was identified because of its low cost, resistance to deactivation, regenerability, and comparable catalytic performance to HZSM-5. However, we agree that the red mud composition and properties will not be consistent as it is not deliberately produced as a catalytic material. To address this concern, our research is and will continue to focus on determining the composition-performance relationship of red mud and on assessing red mud variability based on the source. Using this information, we can evaluate the commercial feasibility of using red mud as a catalyst for in-situ CFP and can identify strategies to produce similar low-cost materials, but with consistent properties.

We agree with the reviewers that processing lignin and cellulose together through CFP is challenging; however, we believe that significant improvements can still be made in this area through design of bi(multi)-functional catalysts and implementation of new process configurations (e.g., catalytic hot gas filtration or dual fixed-bed systems) that enable strategic upgrading based on targeted reaction chemistry.

A HYBRID CATALYTIC ROUTE TO FUELS FROM BIOMASS SYNGAS

(WBS#: 2.3.1.403)

Project Description

LanzaTech, with partners Pacific Northwest National Laboratory, Imperium Aviation Fuels, InEnTec, Orochem Technologies, University of Delaware, Michigan Technological University, National Renewable Energy Laboratory, and the Boeing Company, developed a cost-effective hybrid conversion technology to catalytically upgrade biomass-derived syngas to jet fuel that meets the price, quality, and environmental needs of the aviation industry. The process makes a type of “alcohol-to-jet” (ATJ) synthetic paraffinic kerosene from ethanol. Objectives also included co-product chemicals (e.g. 2,3-butanediol, a precursor to key chemical intermediates). The project successfully demonstrated the viability of a future model with distributed ATJ production fed by multiple ethanol sources and showed the value of co-product chemicals to

Recipient:	LanzaTech Inc.
Principal Investigator:	Mike Schultz
Project Dates:	10/1/2011–6/30/2016
Project Category:	Sun-setting
Project Type:	FY 2011–TC Upgrading: DE-FOA-0000467
Total DOE Funding:	\$1,480,763

reduce ATJ costs, accelerating commercial production of alternative jet fuel from biomass. The project also generated key data for the review process required to add ethanol to D7566 Annex 5, the ASTM (previously an abbreviation for American Society for Testing and Materials) standard for alternative jet fuels. Challenges identified in the project included the following: (1) high capital cost of gasification, addressed by additional integration in future commercial designs, including full utility integration; (2) ATJ catalyst development, addressed through extensive studies, leading to a new oligomerization catalyst that was successfully scaled up and demonstrated; and (3) high cost of co-product separation, addressed by design of a novel separations scheme.

Weighted Project Score: 8.4

Weighting: Approach–25%; Relevance–25%; Accomplishments and Progress–50%.

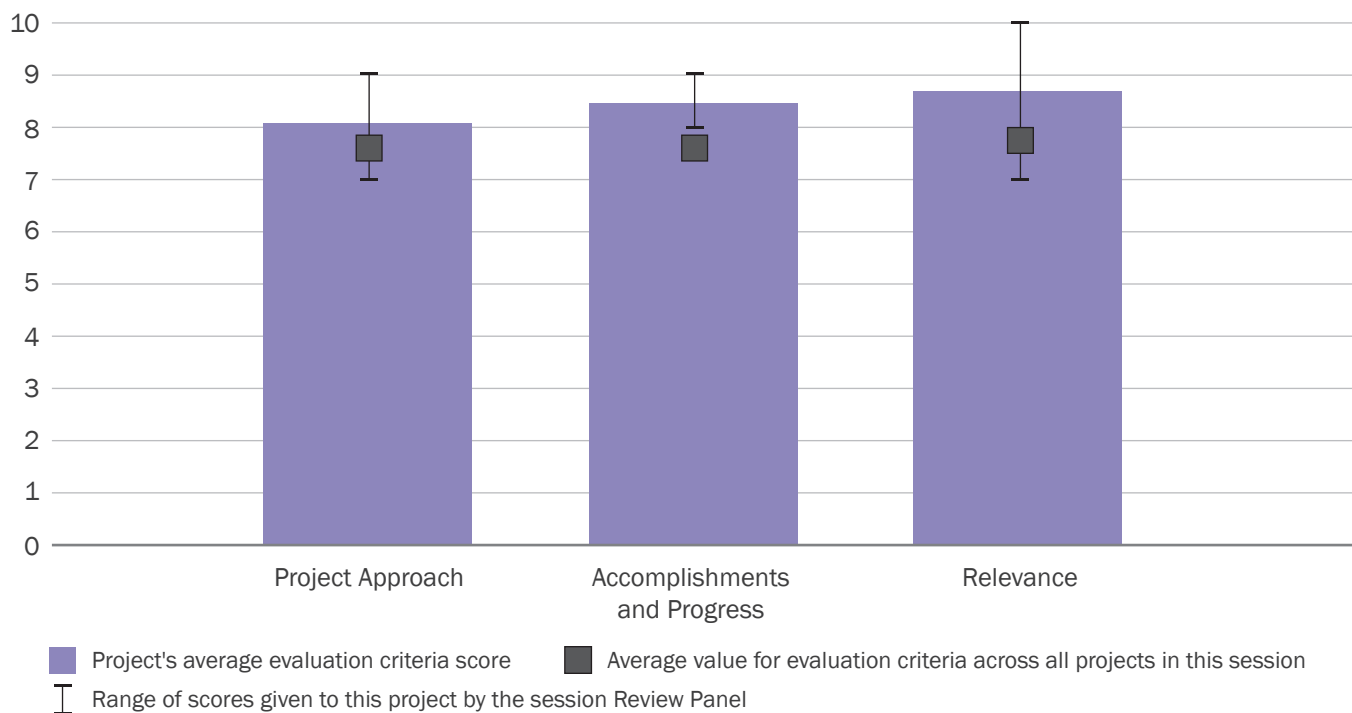



Overall Impressions

- This is an outstanding team work result for pilot scale, meeting BETO objectives and goals. The team did an excellent job managing complex relationships and program integrations to be able to output real fuel for trials. This is one of the top programs I have assessed. My only concern was the lack of mention of potential value of the isolated olefin oligomers. These could further drop the cost from \$3/gge since these go into the detergent market.
- The project successfully demonstrated the production of jet fuel from biomass syngas at a scale sufficient to product material for jet fuel certification. The final products were successfully tested and certified. Previous reviewers' concerns with the difficulty of integrating the chemical and bioprocess proved to be valid. Gasification of biomass is still a technology that needs further development work. Now would be a good time for an independent review of the techno-economics of the process to establish a solid cost of production. Future work should closely track operations, including run times and any operational issues that will lead to lower plant throughput.
- This is an interesting integration of biomass gasification and syngas fermentation for the production of jet fuel. Overall cost-competitiveness is a challenge and will rely on co-production of valuable chemicals.
- Overall, this is a very innovative project that successfully integrated a complete gasification system and a product upgrading system. It is compelling

that this conversion pathway does not require a complex $H_2:CO$ ratio, high pressures, ultra-clean syngas, or high temperatures. However, the fermentation broth is complex, and the economics are reliant on multiple revenue streams coming from both fuels and chemicals. While this project team successfully addressed the gas-cleanup challenges faced by INEOS Bio at the Vero Beach facility, the necessity to generate multiple product streams means there is important work to be done regarding separations and process optimization. That said, a commercial-scale success with this technology would be extremely meaningful.

- This was a very well-designed and well-executed project. The project team clearly understands what needs to be done to successfully commercialize the technology. There are no apparent technical show-stoppers, so commercial viability seems to depend on overall economics. Good luck!

PI Response to Reviewer Comments:

- Thank you for the positive comments. We address three related comments posed by the reviewers.

In response to the paraphrased reviewer comment of “the requirement for integrated gasifier may make it difficult to achieve goals in timely fashion,” in parallel with the project, LanzaTech operated a pilot-scale fermentation unit on MSW syngas for over two years, providing technical confidence in integrated operation on syngas. The project was reformulated to demonstrate integrated operation of LanzaTech’s Gas Testing Station with the InEnTec gasifier for a minimum of one week on each of three biomass feedstocks. Ethanol samples were produced in laboratory fermenters using bottled syngas from each biomass feedstock and used to validate conversion to jet blendstock.

In response to the paraphrased reviewer comment of “this approach is risky since it involves coupling biological and thermochemical systems,” the project

demonstrates that gasification is an effective means of deconstructing different types of biomass into a consistent intermediate for biochemical upgrading to ethanol. The project demonstrated that ethanol as an intermediate isolates the catalytic upgrading from biomass feedstock variability. The ethanol to jet process was successfully demonstrated on ethanol from multiple sources with no impact on performance.

In response to the paraphrased reviewer question of “how this process compares to cost for Fischer-Tropsch (F-T), when the process still requires syngas production and cleanup but adds costly separation steps. It must be driven by the cost of chemical co-products,” gasification is required to produce syngas from biomass for both F-T and gas fermentation processes. Gas fermentation is very flexible because biologic processes can accommodate a wide range of syngas compositions (e.g., $H_2:CO$ ratios). This reduces gasification costs by eliminating the water-gas shift process step needed to control syngas composition for F-T processes. Gas fermentation requires less stringent syngas cleanup, representing a cost

savings. Gas fermentation inhibitors are reversible and once a contaminant is removed, its impact on a microbial gas fermentation system is eliminated. In contrast, even a short contaminant breakthrough can poison millions of dollars of costly F-T catalyst and result in extended downtime.

Biomass F-T project cost estimates often only cover the gasification to F-T crude portion excluding the substantial capital expenditures for conversion of F-T crude to actual fuel products. The steps necessary to process F-T crude, such as hydrocracking, hydroisomerization, and several fractionation columns, are often integrated with refinery operations elsewhere. Note that ethanol to jet conversion is the smallest contributor to capital expenditures in the biomass-based ethanol-to-jet process. While additional separations are required for a chemical co-product such as butanediol, separation costs are more than outweighed by additional product revenues. As shown in techno-economic analyses, inclusion of a chemical co-product enables the cash cost of production for the ATJ product to be competitive with conventional jet fuel.

CATALYTIC UPGRADING OF THERMOCHEMICAL INTERMEDIATES TO HYDROCARBONS: CONVERSION OF LIGNOCELLULOSIC FEEDSTOCKS

(WBS#: 2.3.1.406)

Project Description

The goal of the project is to couple Virent Energy Systems' (Virent's) biomass liquefaction process (solvolysis) with the BioForming® process to convert bagasse, corn stover, and loblolly pine into aromatic-rich fuels and chemicals. The unique ability to effectively solubilize hemicellulose, cellulose, and lignin components of biomass into convertible intermediates sets this process apart from other approaches. Solvolysis involves solvent-assisted liquefaction of biomass coupled with stabilization of the reactive species through the use of catalysts. After stabilization, the intermediates can be

Recipient:	Virent Energy Systems Inc.
Principal Investigator:	Randy Cortright
Project Dates:	10/3/2011–10/2/2015
Project Category:	Sun-setting
Project Type:	FY 2011–TC Upgrading: DE-FOA-0000467
Total DOE Funding:	\$4,000,000

fed into a condensation reactor, producing a stream of aromatic-rich hydrocarbons for use as fuels and high-value chemicals.

Since the project's inception in Quarter 4 of 2011, the team has reached several project milestones, including biomass liquefaction in excess of 95% and soluble oxygenate yields exceeding 80%. The team improved the stability and lifetime of the stabilization catalyst and built, commissioned, and operated a larger-scale, fully continuous deconstruction system. In order to optimize the fully integrated system, a 2,000-hour demonstration

Weighted Project Score: 8.7

Weighting: Approach–25%; Relevance–25%; Accomplishments and Progress–50%.

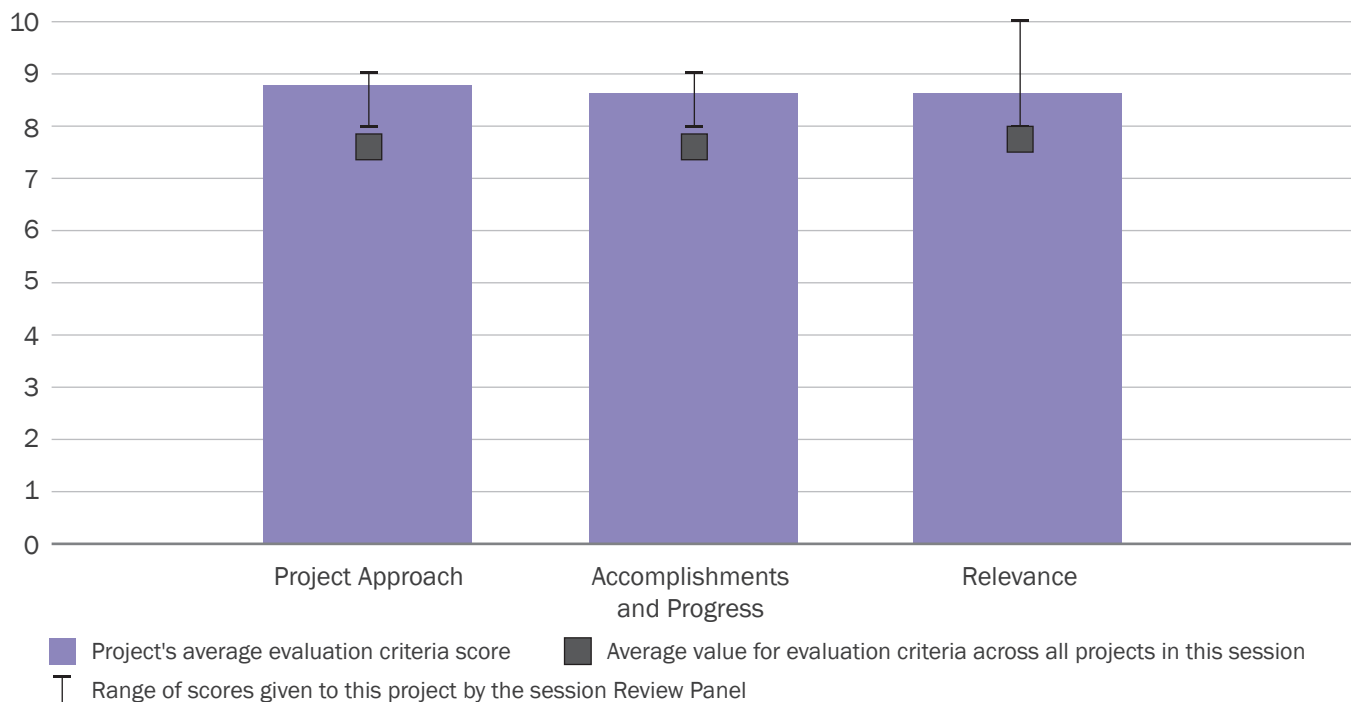

run of the fully integrated system was completed inclusive of process simulation and cost models updated. The project was completed in October 2015, and results will be discussed during the review.

Overall Impressions

- I was surprised that the true values are not on the chart for economics, only showing relative information in slide 18. Is the cost info proprietary to Virent? This is my only question and concern. As always, I think Virent does a great job of putting together programs and being clear about results. Other teams now can benefit from the results since solvents are in several other programs in BETO, as well as conversion technologies of intermediates that are the same in this operation.
- This was a very strong program, showing good integration between the partners at Virent and Iowa State. The solvolysis deconstruction has great promise. As with all pretreatment technologies, the costs versus benefits need to be carefully evaluated. It is becoming clear that thermal treatment of cellulosic and lignin material at the same conditions is problematic and causes low carbon recovery or the production of a very low-quality product. The products from solvolysis have proved to be more easily upgraded by the Virent reforming technology to value-added products.

- This is a well-managed project for conversion of biomass into aromatic products. The technology appears competitive and with the potential for even further improvements.
- Overall, this is a very innovative project with a fascinating approach for solvent liquefaction related to *in-situ* solvent generation and recovery. Solvent chemistry allowed the project to operate at reasonable conditions and solubilize 90% of the biomass, which is very impressive. The 2016 *Billion-Ton Report* makes it clear that grass feedstocks will be considerably more important than wood feedstocks in the future bioeconomy. Project work with corn stover and bagasse increases the relevance of these results to future challenges and proves that the process has an appropriate level of flexibility. However, increasing catalyst life will be fundamentally important for commercial success, and moving to a cheaper, more sacrificial catalyst may be necessary.
- This is a good application of DOE money to support commercial-adjacent technology. The project seems to have a chance at commercial viability.

PI Response to Reviewer Comments

No official response was provided at the time of report publication.

CATALYTIC CONVERSION OF CELLULOSIC OR ALGAL BIOMASS PLUS METHANE TO DROP-IN HYDROCARBON FUELS AND CHEMICALS

(WBS#: 2.3.1.411)

Project Description

The objective of this project is to catalytically convert biomass plus methane to drop-in hydrocarbon liquid fuels and chemicals. The goal of the project is to increase C4+hydrocarbon yields from biomass, while decreasing hydrogen consumption and capital cost. In this project, bench-scale experiments have been completed using the Gas Technology Institute's mini bench unit (1) to catalytically convert model compounds and also (2) to catalytically convert biomass plus methane to drop-in hydrocarbon liquid fuels and chemicals, using methane or methane plus hydrogen fluidizing gas mixtures in catalytic methane/hydrolysis. The hydrogen transfer

Recipient:	Gas Technology Institute
Principal Investigator:	Terry Marker
Project Dates:	2/9/2015–5/31/2017
Project Category:	Sun-setting
Project Type:	FY 2013—Incubator: DE-FOA-0000974
Total DOE Funding:	\$1,485,415

catalyst provided by W.R. Grace has been used to activate the methane so that it reacts with the olefins, free radicals, and oxygenates produced from biomass devolatilization. The project participants are the Gas Technology Institute, W.R. Grace, Algae Energy, the National Renewable Energy Laboratory, and Michigan Technological University.

Overall Impressions

- I take issue with the project basis on one point— literature as foundation for funding. The team, however, did nice job of getting positive results by further exploring possibilities and shifting approach and experiments, once poor results were shown in the laboratory for the initial studies of Ga-ZSM-5.

Weighted Project Score: 8.3

Weighting: Approach–25%; Relevance–25%; Accomplishments and Progress–50%.

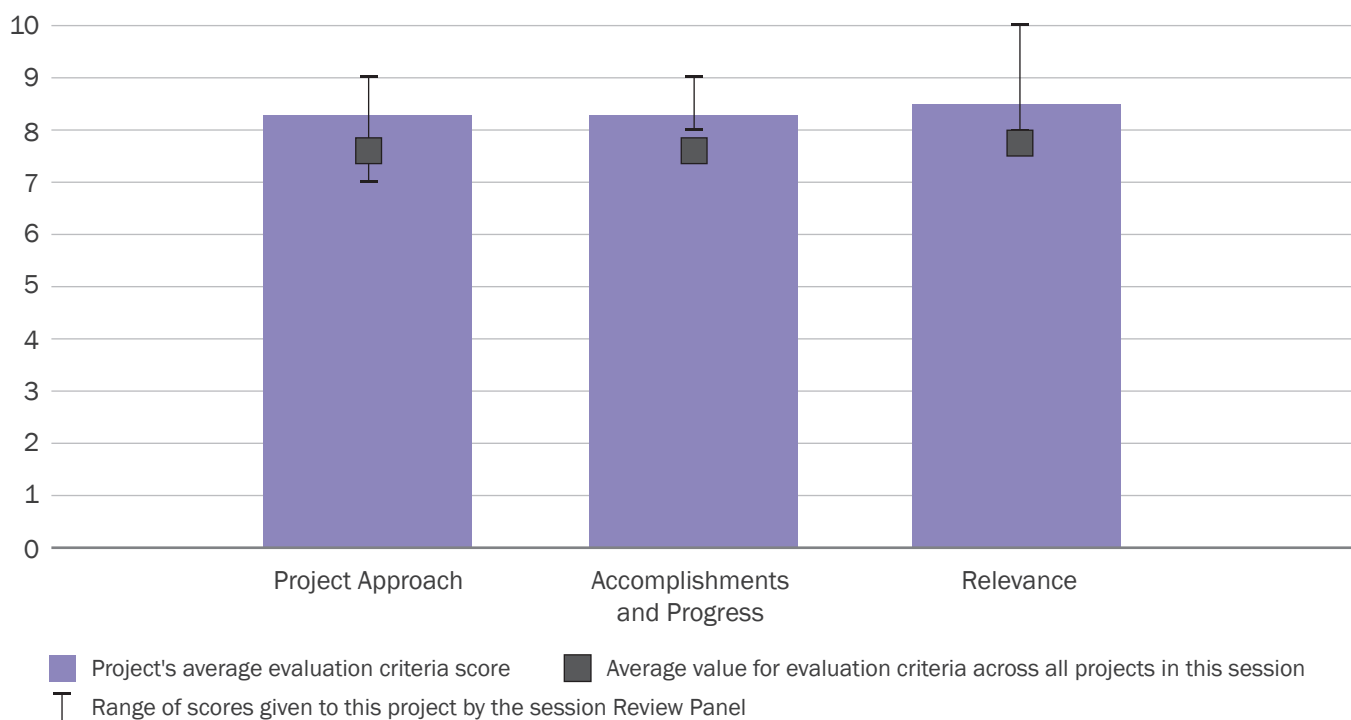

I am also glad to see the use of realistic feeds in the testing. I am not sure that the benefit of going to higher diesel is worth the loss in yield, which is substantially more important.

The higher-temperature improved yield of 16% is unexpected and nice to see. A key question for the team is do they believe optimum reaction temperature is now 482°C? Did they identify the increased temperature sweet spot? An 82°C difference in temperature is huge in thermodynamic terms. Did the team do laboratory experiments on the bench unit at 410–500°C in 10-degree increments and only show the best data in slide 16 at 482°C, which is optimum? Good science dictates temperature ramps in ranges of a maximum of 20°C, and preferred 10°C, to make sure the temperature result is as robust as possible.

Finally, is the intent to use methane really adding substantial value to project? Techno-economic analysis will define. I also am surprised that, once they identified improvement with methane, they did not pursue experiment with natural gas to see if this brought further improvement, since ethane and propane give more hydrogen transfer than methane and natural gas (sulfur removed of course) would give better result than methane accordingly. I am not sure, however, that the economics improves in terms of raw material cost, due to resale value of the separated ethane and propane versus remaining pure methane.

- The Integrated Hydrolysis and Hydroconversion process has the highest carbon retention in fuel of any thermochemical approach to biomass con-

version. The technology is very far along. A critical review of this technology is needed to determine the barriers to its cost. Is it concerned about high-pressure hydrogen use, feed preparation, overall complexity? What is DOE's role in supporting the technology? This project is an extension of prior work that was DOE-funded.

- This is interesting work that will improve the Integrated Hydrolysis and Hydroconversion technology. It would be interesting to confirm if methane could be replaced by natural gas, as such co-feed of natural gas and biomass may be an attractive way to accelerate the use of biomass due to the relatively low price of natural gas.
- Overall, this is a great project with a talented team. Even though methane contribution was minimal, showing any effect at all was significant. Methane is the hardest hydrocarbon target that the team could chose to be catalytically activated for these reactions. Using C2-C4 hydrocarbons should noticeably improve the thermodynamics and still have a positive effect over traditional H₂ hydrogenation approaches. Additionally, economics could be improved further if natural gas liquids or natural gas were utilized instead of methane because a process like this would not suffer from the utilization of a cheaper, mixed hydrocarbon feed. This is a strong step forward in an innovative direction.

PI Response to Reviewer Comments

No official response was provided at the time of report publication.

INTEGRATION AND SCALE-UP + THERMOCHEMICAL (TC) CAPITAL EQUIPMENT

(WBS#: 2.4.1.301)

Project Description

This project uses the Thermochemical Process Development Unit (TCPDU), a more than 0.5 ton/day pilot plant, to verify thermochemical biomass conversion catalysts, processes, and other technologies developed at the lab scale. The project team develops engineering solutions necessary for scale-up, thereby enabling commercialization and reducing cost and risk to industry. The TCPDU can be configured for fast pyrolysis, *ex-situ* catalytic fast pyrolysis, and indirect liquefaction pathways. It has been a BETO asset for over 20 years, contributing to achieving BETO goals and being used by industry. This project also provides samples and

Recipient:	National Renewable Energy Laboratory
Principal Investigator:	Esther Wilcox
Project Dates:	10/1/2014–9/30/2017
Project Category:	Ongoing
Project Type:	Annual Operating Plan
DOE Funding FY 2014:	\$3,000,000
DOE Funding FY 2015:	\$2,100,000
DOE Funding FY 2016:	\$2,500,000
DOE Funding FY 2017:	\$2,500,000

pilot-scale data to support numerous other research efforts.

The primary challenge is designing systems prior to completion of lab-scale research in order to have operational pilot-scale systems for technology verifications. The team overcomes this challenge by communicating with the researchers to understand the potential needs, designing in flexibility, and providing design limits to guide the research. Recently, we designed, fabricated,

Weighted Project Score: 8.0

Weighting: For ongoing projects, there is equal weighting across all four evaluation criteria: Approach, Relevance, Accomplishments and Progress, and Future Work.

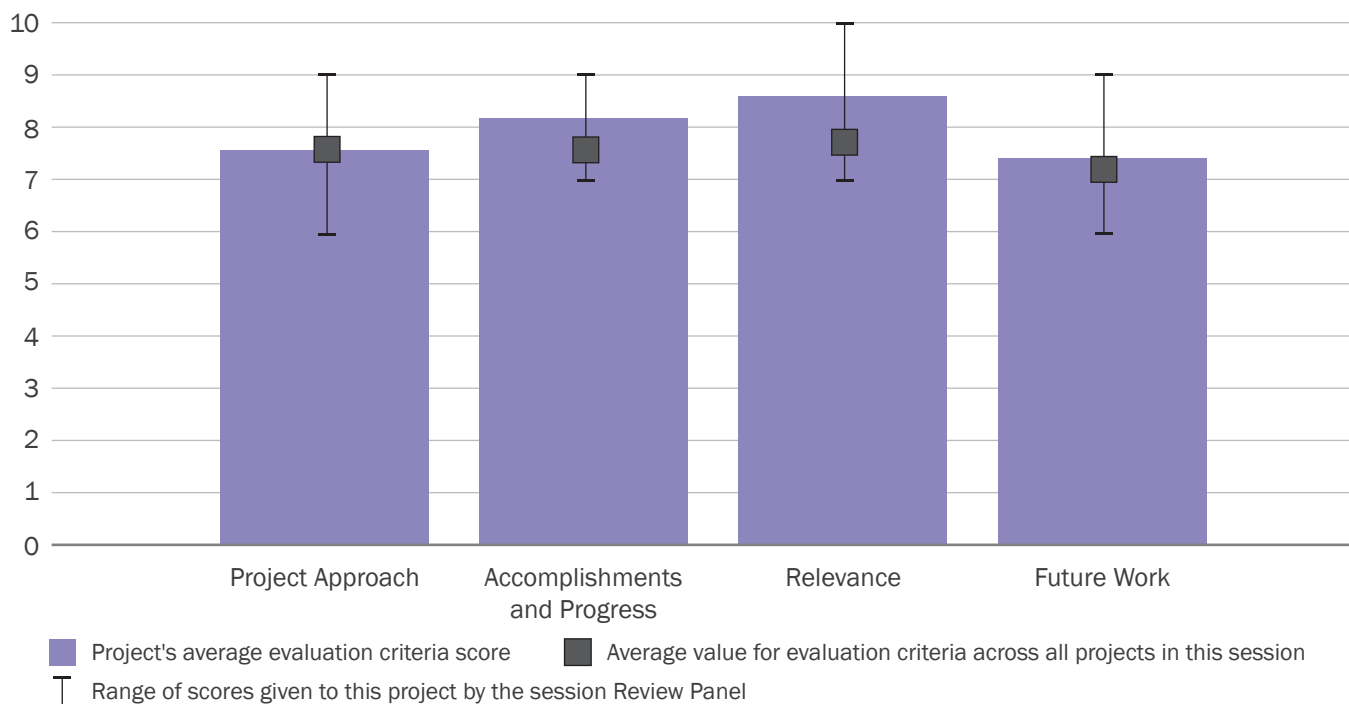

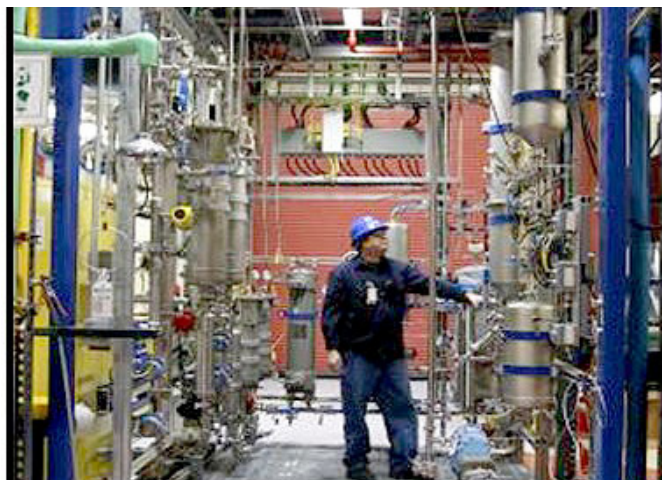

and installed two new unit operations in the TCPDU. This added *ex-situ* catalytic fast pyrolysis capabilities, which will be used for BETO's FY 2022 verification. In FY 2017, the TCPDU produced more than 200 gallons of fast pyrolysis oil from an industrially relevant blended feedstock to enable achievement of BETO's Government Performance and Results Act goal. The oil met performance targets and is being hydrotreated at Pacific Northwest National Laboratory (PNNL) to complete a pilot-scale fast pyrolysis pathway verification.

Overall Impressions

- The team has done great job to solve issues on pilot-scale designs, provide pyrolysis oil for upgrading teams, and keep work on track to meet the needs of the various teams. I see no issue with results to date.
- Creating a separate project for design, construction, and maintenance of the national laboratories' pilot plants is a good idea and allows for coordination and standardization. The approach of the team and project management looks good. Economic and timing constraints have placed constraints on the experimental design. For example, the need to adapt a gasifier feed system and entrained flow reactor in the pyrolysis scale-up may limit yields due to heat transfer and residency time effects.

- The need to split the pyrolysis conversion and upgrading adds some uncertainty to the integration work. It would be much better to have the two tests collocated. My experience is that hydroprocessing aged feeds is different than hydroprocessing fresh feeds.
- This is an excellent project that provides important support for accelerated commercialization of bioenergy technologies and catalysts. Having a common, flexible pilot plant facility with an experienced crew will make pilot demonstrations more economical and reliable.
- Overall, this is solid work. It is very difficult to build, commission, troubleshoot, and operate a fully integrated system, and the hard work and successes of this team are clearly reflected in the hours on stream and the reliability of the system. Several innovative approaches appear to have been developed to get this system online and running under steady-state conditions, which is impressive. However, now that a platform system exists, additional unit operations should be added to improve the capabilities of the process and to give it unit operations more in line with current commercial trends. This is not something the project could have planned for, but it is something that should be addressed in the future.
- I am very much in favor of continuing this effort. A dedicated pilot plant support effort, focused on technology integration and scale-up, will provide value for the long term, regardless of the specific technologies investigated in the future.

PI Response to Reviewer Comments

- We have taken into consideration the concern regarding fluid bed versus entrained flow reactors. Based on experimental results, the TCPDU entrained flow reactor performs comparably to the bench-scale fluid bed systems. There is currently

an ongoing effort with the Consortium for Computational Physics and Chemistry to model both the entrained flow reactor and fluid bed systems. The entrained flow reactor does provide some advantages, from a research perspective, that fluid beds cannot, such as independently changing the residence time. Since the TCPDU is intended to be a flexible research pilot plant, we can design and install a fluid bed pyrolyzer if it is deemed critical to industry and the capital funds are provided for the effort.

We agree with the reviewers' concerns regarding co-location of hydroprocessing. The National Renewable Energy Laboratory houses the pyrolysis pilot plant, and PNNL possesses the demonstration-scale hydrotreating capabilities. Given the ex-

pertise and equipment available at both laboratories and the needs of the verification, we determined to separate the processes. The efforts at PNNL leading up to the verification included hydrotreating aged pyrolysis oils, thereby minimizing the risk associated with not co-locating the processes. All oils were maintained in cold rooms and were cold-shipped to PNNL to minimize aging.

We will initiate a directed effort in FY 2018 based on the Energy I-Corps (previously LabCorp) approach, which will entail reaching out to industry, gaining an understanding of the challenges they face, and then aligning our R&D activities to meet industry needs.

CATALYTIC UPGRADING OF THERMOCHEMICAL INTERMEDIATES TO HYDROCARBONS – RESEARCH TRIANGLE INSTITUTE

(WBS#: 2.4.1.403)

Project Description

This project demonstrates a technology that integrates catalytic biomass pyrolysis with hydroprocessing to produce advanced hydrocarbon biofuels. RTI International is developing a novel single-step catalytic biomass pyrolysis process to produce a hydrocarbon-rich biocrude intermediate. Haldor Topsøe has developed a strategy for upgrading biocrude intermediates based on extensive hydroprocessing catalyst and process development expertise. The technical goals are to optimize the catalytic biomass pyrolysis process to produce a

Recipient:	RTI International
Principal Investigator:	David Dayton
Project Dates:	10/1/2011–9/30/2016
Project Category:	Sun-setting
Project Type:	FY 2011–TC Upgrading: DE-FOA-0000467
Total DOE Funding:	\$4,349,928

low-oxygen-content, thermally stable biocrude intermediate and evaluate the impact of biocrude quality on the hydroprocessing step. The desired outcome for the integrated process is to minimize hydrogen demand while maximizing biofuels yield. We scaled up the catalytic biomass pyrolysis process to a 1 ton/day pilot unit, and a commercially scalable hydroprocessing unit has been designed, built, commissioned, and operated. The project team has produced more than 200 gallons of biocrude and achieved more than 2,000 cumulative hours of upgrading.

Weighted Project Score: 7.2

Weighting: Approach–25%; Relevance–25%; Accomplishments and Progress–50%.

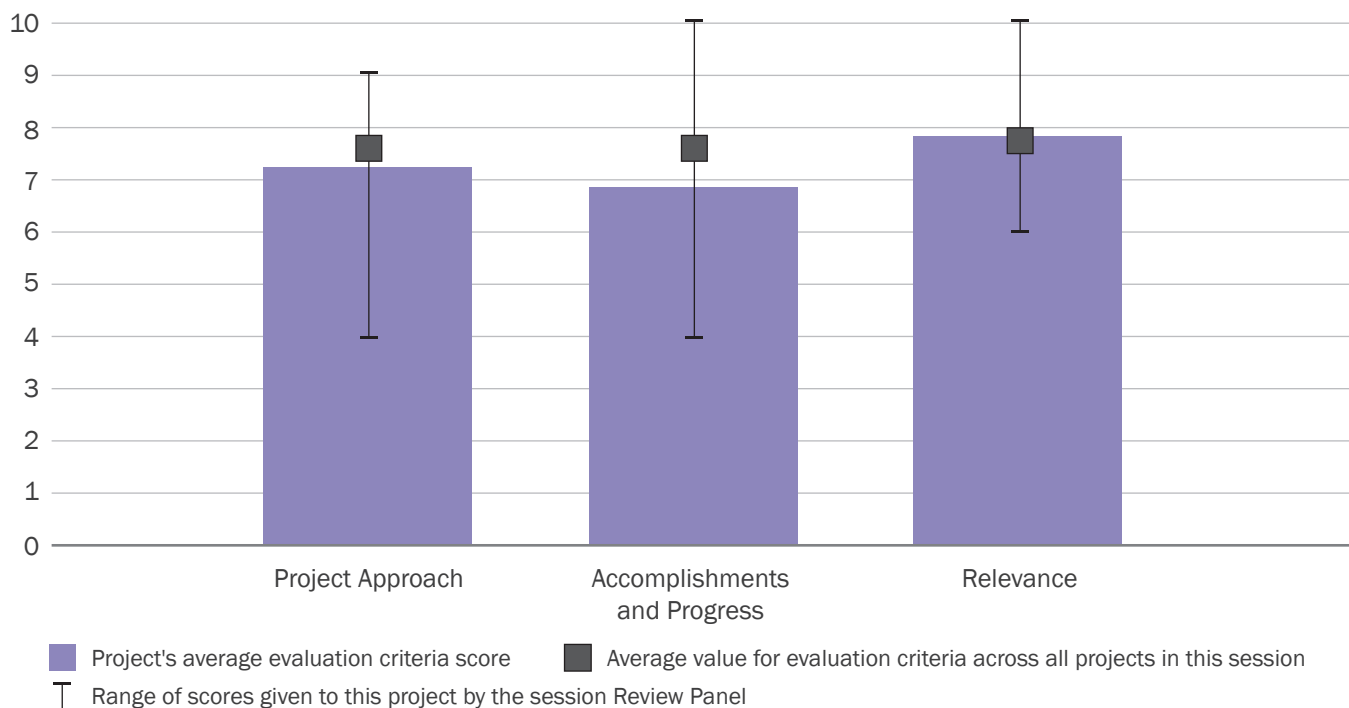



Overall Impressions

- These are well-orchestrated project scale-up and integration results on a challenging area of work for the pilot scale, i.e., bio-oil and upgrading. I have no concerns over the data or results generated. This was a well-presented project as well. The team did an outstanding job overall. My concern with the bio-oil catalyst upgrading is with future feedstocks and ash associated, which will be the biggest challenge for catalytic pyrolysis issues.
- The scale-up of the catalytic pyrolysis process is a major accomplishment, but the performance of the plant was questionable. Hopefully, the report will include details of the operation and equipment, explaining what happened. This would be a great learning tool for future projects in this area. It would be a shame for these details to be lost.

Greater care in planning is required to ensure that feed and catalyst are available in the quantities needed to run the plant. Additional partners should have been found or additional funds requested for these purposes.

- This is a great project with good results.
- Overall, this is a solid project that showed that it is technically feasible to consistently generate 20% O₂ pyrolysis liquids and that these liquids can be effectively hydrotreated into low-oxygen fuel blendstocks. However, technical success often does not lead to commercial or strategic success, and in this case, the process intensity in combination

with the realistically low commercial value of the product means that new approaches for constructively utilizing these processes and equipment must be explored. Focusing on the conversion of whole, unmodified biomass makes the probability of generating a valuable end product very low. Like produced crude oil, separations can and should begin before the high-temperature processes happen. Furthermore, from a process objective perspective, pyrolysis conversions have more in common with a fractional distillation tower than they do with a fluid catalytic cracking unit. Biomass can be broken into fiber, lignin, and extractive fractions fairly easily, and pyrolysis of these individual fractions will absolutely generate a narrower product distribution that should be easier to upgrade/separate efficiently. The project should take its highly impressive pyrolysis reactor testing setup and apply it to biomass fractions that are commercially available, like crude fiber and cellulosic ethanol lignin. Trying to solve these challenges through brute force H₂ hydrogenation is unlikely to be constructive in the long term.

- This is a continuation of a technical approach that has been well-studied. In my opinion, this project did not demonstrate any novel pathways or catalytic results compared with the state of the technology at project start. I do not see an obvious path forward for this technology, absent a major breakthrough in catalytic fast pyrolysis product yield and quality and catalyst stability.

PI Response to Reviewer Comments

- This project was a continuation of laboratory-scale catalyst and process development supported by a DOE/ARPA-E project awarded in 2009. The scope of this project was to evaluate the integration of catalytic fast pyrolysis with hydrotreating to produce advanced biofuels. The design, construction, and commissioning of the 1 ton/day pyrolysis unit was completed in the DOE/ARPA-E project. This

project supported the operation of the unit. Early experiments were hampered by fouling of a heat exchanger that was originally installed directly downstream of the spray quench. This design was not suitable for long-term operation, so a new design was developed and modifications were implemented. The quench system modifications that are still in use today significantly improved system operability and led to the operational success of the unit. The project team surpassed the biocrude production target deliverable of 75 gallons with a total biocrude production of 230 gallons for upgrading.

This project also supported the design and fabrication of a laboratory-scale hydroprocessing unit. This unit was successfully commissioned and operated to meet project deliverables amid certain operational challenges expected with such larger research units. The hydroprocessing studies at RTI on vacuum gas oil and biocrudes were performed for close to 2,000 hours; specifically, upgrading of pine and oakwood biocrudes were performed for more than 1,500 hours. The original upgrading target for the project was a total of 2,000 hours of biocrude upgrading. Additionally, Haldor Topsøe performed the co-processing studies of hydrotreated liquid products from pine and oakwood with straight run gas oil and light cycle oil were performed for more than 1,800 hours.

Pilot-scale quantities of catalyst and feedstock are more difficult to find than sufficient quantities needed for small laboratory systems, but we found sources of both catalyst and feedstock to meet the project needs. We used feedstock from a previous DOE/BETO project (the National Advanced Biofuels Consortium), and after the first go/no-go decision point, we worked with Idaho National Laboratory to obtain additional feedstocks. Unfortunately, the material we received from Idaho National Laboratory (4 tons of ground hybrid poplar) did not

successfully feed in our system. The bulk density was too low, and the material bridged in the lower section of the feeder. We worked with Idaho National Laboratory to try and get material that was more suitable, but their pilot-scale feedstock preparation unit proved too inflexible to significantly alter the physical properties of prepared biomass to be of use to the project. We eventually found a local provider of loblolly pine sawdust that was suitable for our system. We also went back to Iowa State University (the source of the National Advanced Biofuels Consortium feedstock) and procured red oak sawdust that we successfully converted to biocrude in our system.

Different commercially available catalysts, such as fluid catalytic cracking and non-zeolite alumina catalysts, were also evaluated. While we were not able to scale up the catalyst identified and developed in the previous ARPA-E project, we could find a commercially available alumina catalyst that was available in sufficient quantities to run our system. Laboratory testing validated the performance of the alumina catalyst, and it was used to produce over 230 gallons of biocrude.

Several technical challenges remain before catalytic biomass pyrolysis becomes a commercial reality; most notably, biocrude yields and quality still need to be improved. A lot of activity in this area occurred in the past 10+ years, with notable successes and failures; however, very little technical information is available in the open literature from pilot-scale studies, such as those performed in this project. This project showed that it is technically feasible to reproduce small-scale pyrolysis yields at the 1 ton/day scale and consistently generate 20% O₂ pyrolysis liquids that can be effectively hydro-treated.

BIOMASS-DERIVED PYROLYSIS OIL CORROSION STUDIES

(WBS#: 2.4.2.301)

Project Description

Thermochemical liquefaction of biomass offers a promising means to produce liquid fuels and high-value chemicals from a wide variety of biomass sources. The high oxygen content of biomass results in formation of a wide variety of oxygen-containing organic compounds, including carboxylic acids, aldehydes, and ketones, which can cause significant degradation of metallic and non-metallic (elastomers, plastics, etc.) materials. The organic acids in bio-oils can result in an acidity that is the equivalent of a pH in the 2–3 range, thus presenting a corrosion concern for many metallic structural materials. Other carbonyl-containing compounds can degrade many non-metallic materials. This project seeks to identify the bio-oil components degrading materials and to identify materials with sufficient resistance for use in bio-oil production, processing, and storage environ-

Recipient:	Oak Ridge National Laboratory
Principal Investigator:	Jim Keiser
Project Dates:	10/1/2016–9/30/2019
Project Category:	Ongoing
Project Type:	Annual Operating Plan
DOE Funding FY 2014:	\$1,265,000
DOE Funding FY 2015:	\$1,600,000
DOE Funding FY 2016:	\$1,600,000
DOE Funding FY 2017:	\$1,600,000

ments. Identification of corrosion-resistant materials is essential if promising liquefaction technologies are to be taken to the commercialization stage. The wide variety of liquefaction methods and processing technologies result in unique environmental issues and, consequently, unique material requirements for each liquefaction scheme. Our studies have identified many organic compounds that could degrade structural materials, as well as corrosion mechanisms that are operative in these environments. We have identified improved materials, and samples are being exposed in operating systems in North America and Europe.

Weighted Project Score: 8.2

Weighting: For ongoing projects, there is equal weighting across all four evaluation criteria: Approach, Relevance, Accomplishments and Progress, and Future Work.

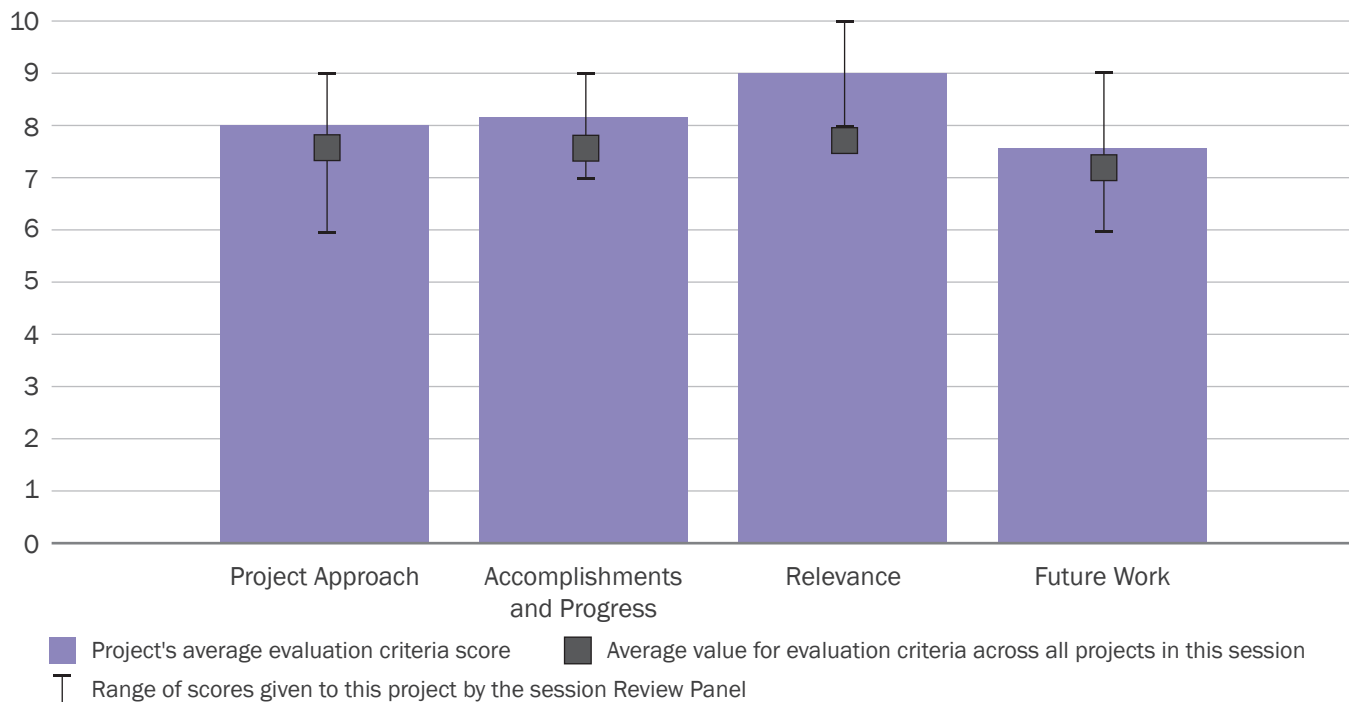

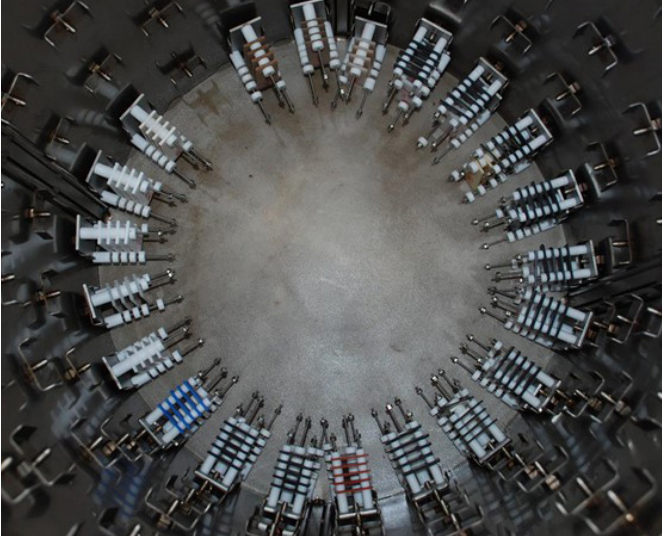

Overall Impressions

- This is a solid work result program, as corrosive studies are always challenging in industry and particularly so for such complex chemical mixtures, such as bio-oils. I applaud the team for using blends of real compounds to study for early insight into impact of mixtures that are well-defined. Broadening work to other feedstocks will be critical.
- This project is close to a perfect example of how the capabilities of national laboratories can be used to support the development of an industry. The information collected is of general interest, and they are willing to take on specific projects when requested at little or modest costs.

Equipment designers must have information on the compatibility and corrosion of materials to design robust plants. The choice of materials has a major effect on the costs of equipment and plant operability. The experimental results presented provide vital information to plant designers and potential bio-oil customers. There are data available concerning both metals and polymers. The information concerning the relationship between oxygen type and corrosion will help establish targets for the future.

- This is a comprehensive project focusing on the very important issue of corrosion by bio-oil and

intermediates in production equipment, as well as storage and transportation. There are, of course, numerous construction materials available, and it may be difficult to focus in on the best candidates. It was not clear from the presentation how the selection of the materials to be tested was handled.

- Overall, this is a great project working to advance a fundamental need of the industry that is often overlooked until it's too late. Identification and development of materials that are resistant to pyrolysis liquids is extremely important. The focus on low-cost, economic materials makes this work even more valuable. Given that pyrolysis liquids have more in common with blackstrap molasses than they do with petroleum products, there should be additional inquiry into the metallurgical experiences that the molasses industry has had. There could also be some interesting materials comparisons with the furfural and pulp and paper industries, given the kind of conversions they typically carry out on both woody and grassy biomass.
- This is a very important project for biomass utilization. While this is a large project in terms of time and dollars, corrosion issues are likely to be encountered for most anticipated feedstocks, so building knowledge of corrosion mechanisms and correlations with feedstock composition will be critical to enabling commercial development. I strongly recommend continuation of this work, whether as a separate team or as a funded task within other funded projects.

PI Response to Reviewer Comments

- We greatly appreciate all the positive comments provided by the reviewers, and we will do our best to maintain a high standard of performance and identify the most suitable materials for the various processes and processing conditions.

BRAZIL BILATERAL—NREL PETROBRAS CRADA

(WBS#: 2.4.2.303)

Project Description

The Petrobras–National Renewable Energy Laboratory (NREL) Cooperative Research and Development Agreement (CRADA) aims to demonstrate preliminary technical and economic feasibility of co-processing raw fast pyrolysis oil in fluid catalytic cracking (FCC) operation in a conventional refinery. The project is part of the Strategic Energy Dialogue between the governments of the United States and Brazil in advanced biofuels. Using Ensyn pine pyrolysis oil, the project produced 400 gallons each of diesel and gasoline co-processed precursor fuels that enabled industrial partners to produce hydro-treated finished fuels in the United States. The finished fuels met U.S. specifications, thus leading to the approval of the co-processing pathway by the U.S. Environmental Protection Agency and California Air Resources Board (2015/2016). CRADA results at 5 weight percent

Recipient:	National Renewable Energy Laboratory
Principal Investigator:	Helena Chum
Project Dates:	10/1/2007–9/30/2016
Project Category:	Sun-setting
Project Type:	Annual Operating Plan
DOE Funding FY 2014:	\$100,000
DOE Funding FY 2015:	\$115,000
DOE Funding FY 2016:	\$87,000
DOE Funding FY 2017:	\$0

(wt%) and 10 wt% bio-oil and vacuum gas oil (VGO) were published in *Fuel*, volume 188, and a prior Petrobras paper (in *Fuel Processing Technology*, volume 131) enabled NREL to develop two co-processing models. With these models, we examined the economic feasibility of many co-processing scenarios. Co-processing at 5% py-oil with VGO is economically feasible in the near term. At 10%, it is promising with progress in the pyrolysis industry in reducing costs (scale) and technology. The impact of 5% FCC co-processing with VGO is similar to that of a 1,000–1,200 tons/day cellulosic fuel facility with minimal refinery investment. The direct

Weighted Project Score: 8.4

Weighting: Approach–25%; Relevance–25%; Accomplishments and Progress–50%.

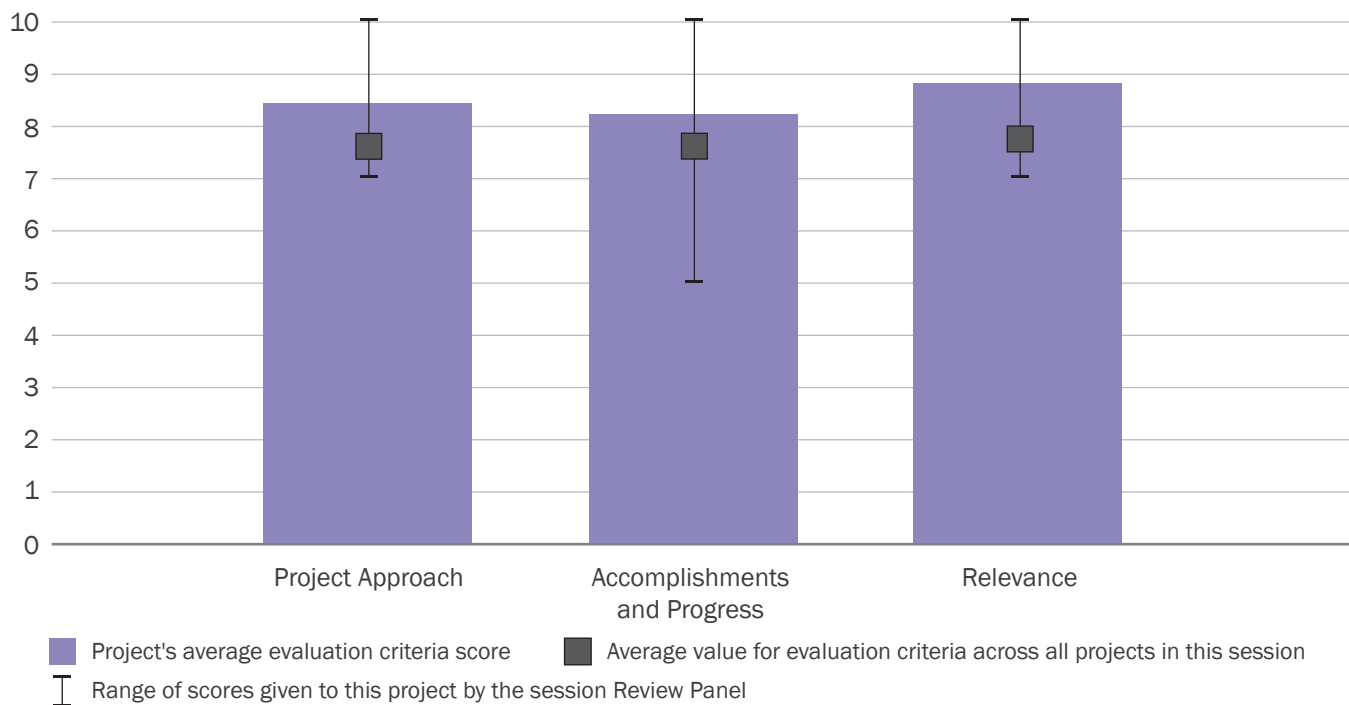



FCC co-processing of pyrolysis oil in a refinery has the potential to contribute significantly towards U.S. (e.g., Renewable Fuel Standard, California Air Resources Board's Low Carbon Fuel Standard) and global future biofuels goals.

Overall Impressions

- This is an outstanding program of cooperation with Brazil and Petrobras to define feasibility. I am concerned that some incentives are necessary if this blend approach is to be implemented in the near term. I am not sure about your statement that co-processing at 5% is economically feasible in the near term without incentive due to the price of oil in \$50/barrel range currently in the United States. What is the intention of DOE in terms of encouraging this implementation in the near term in the United States? I did not see any specifics on how this will be potentially moved forward beyond finalization of the modeling and life-cycle analysis. Since bio-oil was old, I am unsure what the impact of fresh oil would be on process. Are there any plans to address this concern that results might be substantially different and hard to predict? Also, the project only used the easiest feedstock to process. When would grasses be assessed?
- This project is a good example of international cooperation between commercial companies and a national laboratory. The results from this project are very relevant to the future of fast pyrolysis. Adding bio-oil to an FCC unit is likely the fastest way of incorporating it into a refinery and obtaining the environmental positive impact of displacing fossil fuels. I am still not entirely convinced that gas yields from the reaction of the bio-oil do not limit the carbon efficiency of the process. The Ensyn fast pyrolysis plants have already been commercialized. The techno-economic and life-cycle analyses conducted by NREL provide information that validates the Ensyn information in commercial proposals. It is possible that localities with aggressive environmental programs, like California, will decide to be early adopters of this co-processing approach.
- This is an excellent project that is very well-executed and provided promising results that should accelerate the commercialization of biofuels projects. This is a great collaboration across borders between a DOE laboratory, refiner, and bio-oil supplier.
- Overall, this is a fascinating and extremely useful project that enables important insights into benefits and drawbacks of inserting pyrolysis liquids into a petrochemical FCC unit. While this work is extremely intriguing, questions around the economic decisions underpinning commercial viability are legitimate. It may be that what was proven here was that commercial-scale integration is possible, but it should be done with an independent unit operation (alongside the traditional petrochemical unit ops), and it should be optimized to accept primarily pyrolysis liquids and then convert them into something inherently valuable to the refinery. The ultimate objective here has to be direct and provable contribution of the pyrolysis liquids to the fuel products.
- Very nice work. Demonstration at steady-state conditions for longer runs and/or at near commercial scale is the key next step, along with tightening up the biogenic carbon analysis. If pyrolysis oil is simply acting as a char (and light gas) machine, there may

be alternate technologies that are more economical (e.g., burning pyrolysis oil directly for heat/power).

PI Response to Reviewer Comments

- We thank the reviewers for their very positive comments on our demonstration of steady-state conditions at near-commercial-size scale of co-processing bio-oil with VGO in an FCC unit operating at 200 kg/hour of a Petrobras demonstration, development, and troubleshooting unit.

Specific responses:

- **Total run time.** Regular FCC test protocols set 1 hour as the run time for FCC pilot riser units (Davison Circulating Riser). The demonstration-scale FCC unit is equipped with a pseudo-adiabatic riser reactor and a continuous catalyst regenerator, operating under steady-state conditions. Thus, the catalyst is being continuously burnt during the test. We used 2 or 3 hours run time for each test. However, the entire first set of experiments (using the “young” 9-months-old bio-oil) was carried out by varying operating conditions—such as bio-oil feed rate, as shown in our paper (Fig. 6a), and feed temperature—during more than 70 hours, without any need to stop the unit. Moreover, another long-duration test was carried out to produce high amounts liquid effluent (gasoline and diesel cuts), which lasted more than 70 hours. It is important to emphasize that, although the riser reactor diameter is 2 inches, we did not observe any coke formation inside the riser after the first set of experiments. Nevertheless, Petrobras believes that some of the effects of bio-oil co-processed, if they behave differently from regular heavy VGO feedstocks, could only be detected in a commercial riser reactor because some of features of the test unit geometry do not emulate perfectly a commercial riser reactor. Therefore, a commercial test, which would require much larger amounts of bio-oil, would be necessary to clarify concerns related with coke formation and catalyst deactivation caused by alkali metals. On the other hand, corrosion effects caused by the presence of CO₂ in the water may be reliably simulated by using ionic simulation.
- **Bio-oil age.** The same bio-oil from Ensyn was used twice: the first time when it was 9 months old and the second time when it was 21 months old (see our paper). However, Petrobras assumes that bio-oils deteriorate when they age, polymerizing and producing higher-molecular-weight compounds, which would theoretically yield less-valuable products. Therefore, these results would be conservative if compared with “brand new” bio-oil results. Moreover, although coke-plugging events were observed with the 21-months-old bio-oil, product yield profiles were not altered when compared with the 9-months-old bio-oil.
- **Carbon efficiency.** The co-processing approach requires a reliable method to confirm the amount of renewable carbon in the products because fossil and renewable streams are being blended at some point in the refinery. Therefore, our initial approach used the 14C analysis to measure renewable carbon in the liquid product. We are confident that at least 30 wt% of the total carbon in the bio-oil ends up in the liquid fraction. Two different sets of experiments with two pinewood bio-oils from different producers confirm this value. Therefore, it is not possible that bio-oil is producing solely char, CO, and CO₂, since significant levels of renewable carbon were measured in different gasoline- and diesel-range cuts in many different experiments (two of them were already published, while other results were not published at the moment). CO₂ rejection was 0.4 wt% and 0.6 wt% from experiments with 5 wt% and 10 wt% of bio-oils. It is worth noting that bioprocesses such as sugar fermentation reject, as

CO₂, 50% of the total carbon present in the sugar (i.e., its efficiency is 50% only), and it is not possible to use lignin as raw material, only cellulose and hemicellulose. However, we understand that higher carbon efficiency must be pursued, and it is possible that the co-processing of raw bio-oil in catalytic cracking units represent only an initial step to a better use of the bio-oils in the future. Chemical evidence of incorporation of renewable carbon in the liquefied petroleum gas fraction was found.

CONSORTIUM FOR COMPUTATIONAL PHYSICS AND CHEMISTRY

(WBS#: 2.5.1.301-6)

Project Description

The Consortium for Computational Physics and Chemistry (CCPC) is a team of five national laboratories (Oak Ridge National Laboratory, Argonne National Laboratory, Pacific Northwest National Laboratory, the National Renewable Energy Laboratory, and the National Energy Technology Laboratory) with a common goal to accelerate progress on experimental BETO projects toward critical program verification goals and successful techno-economic analysis outcomes. The CCPC is an enabling project of the ChemCatBio consortium, and it collaborates with experimental projects across the BETO Conversion R&D Program, including the Feedstock-Conversion Interface Consortium and integration and scale-up projects. In addition to close collaboration with experimental teams, the CCPC utilizes an experienced industry advisory panel to guide technical scope

Recipient:	Oak Ridge National Laboratory, Argonne National Laboratory, Pacific Northwest National Laboratory, National Renewable Energy Laboratory, National Energy Technology Laboratory
Principal Investigator:	Stuart Daw
Project Dates:	10/1/2015–9/30/2018
Project Category:	Ongoing
Project Type:	Annual Operating Plan
DOE Funding FY 2014:	\$2,655,515
DOE Funding FY 2015:	\$3,135,000
DOE Funding FY 2016:	\$3,085,106
DOE Funding FY 2017:	\$3,276,500

and ensure industrial relevance. The CCPC creates process and catalyst models to address bio-complexity, scalability, and catalyst discovery challenges. Critical outcomes include (1) process models that capture feedstock complexity and accurately predict reactor performance at multiple scales, as well as (2) predictions

Weighted Project Score: 8.6

Weighting: For ongoing projects, there is equal weighting across all four evaluation criteria: Approach, Relevance, Accomplishments and Progress, and Future Work.

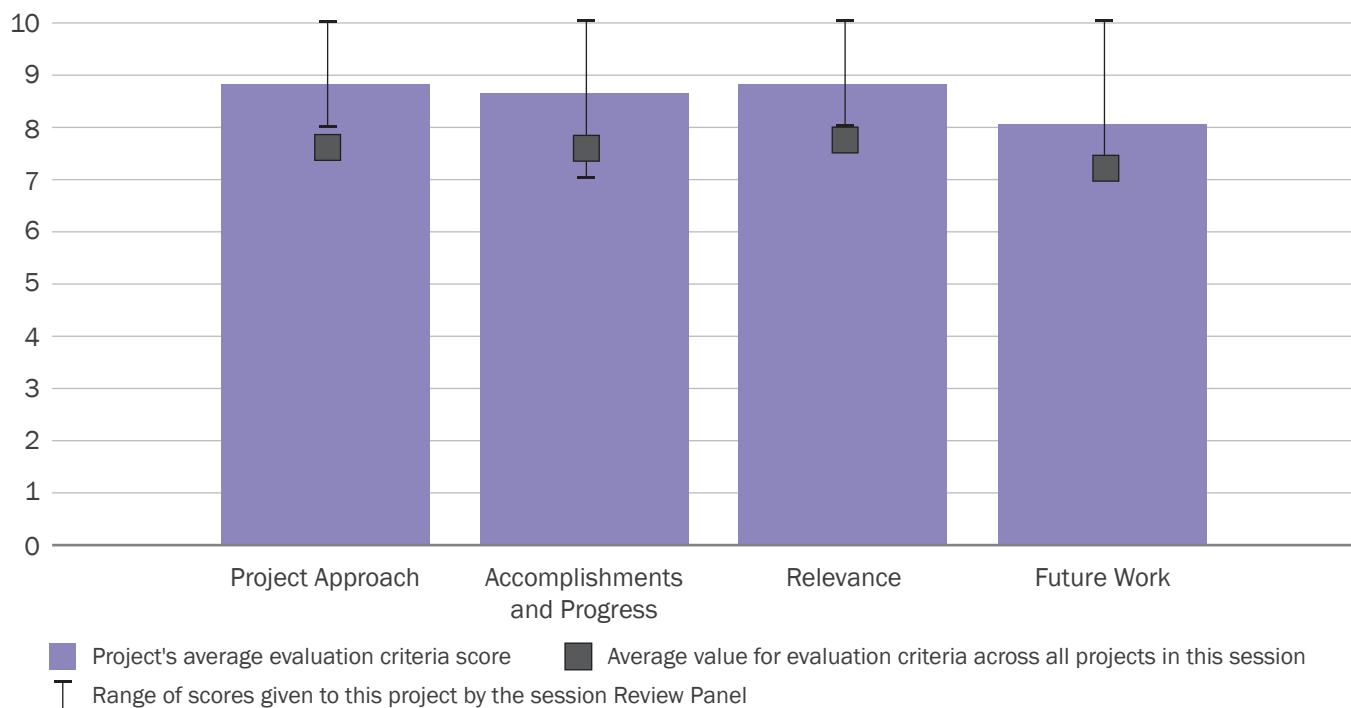

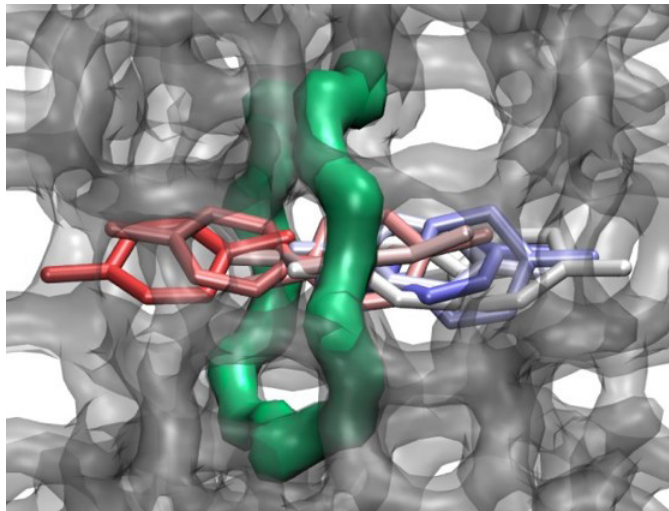

and testable hypotheses that accelerate ChemCatBio's synthesis of new catalysts with improved lifetime, activity, and selectivity. Since the last Peer Review in 2015, the CCPC has authored 30 publications and 29 presentations and has transferred technology related to toolsets for reactor modeling and catalyst discovery.

Overall Impressions

- There is an impressive amount of work for programs. The budget is quite high but necessary for all teams to succeed and accelerate programs. Continue what the team is doing as they are doing well. Do not change anything. There is an impressive amount of publications as well since the last review. I applaud the team and their ability to influence and impact programs in such a complex set of programs. I give this team my highest ratings.
- There is a very high impact for the cost of the project. One wonders where the resources are coming from to accomplish all that was reported and if this can be continued in the future. Predicting the performance of process from small-scale experiments requires a strong modeling effort that can identify potential problems. The phase behavior in the converter and the effect of particle and reactor hold up as the scale increases are critical factors that can be predicted using the models developed by this group.

It will be particularly important to access the effects of the reactor configuration, including the shape, size, inlet design, etc.

- This is a great project with lots of valuable information available for other bioenergy projects. The industry advisory panel helps focus the work on areas that will accelerate the commercialization of bioenergy technologies. The project leverages several experts from multiple laboratories and organizations. This is exciting work.
- Overall, this is a solid program with a number of significant historical contributions, as well as quite a few potentially promising contributions in the future. Models are a critical component for both communication and commercialization. CCPC's high level of competency and expertise in this area is priceless for both BETO and the public. Focus on scalability, bio-complexity, and basic catalysis science is spot on and reflects good understanding of most of the major variables that drive commercialization in the bioenergy/biofuels industry.
- These are impressive project accomplishments to date. Congratulations! If the modeling tools can be successfully applied to the benefit of the catalytic project teams, this will have been a very valuable program.

PI Response to Reviewer Comments

- The CCPC team appreciates the reviewer comments. In general, reviewers expressed positive comments on project approach, accomplishments, relevance, and future work; thus, the team plans to continue overall direction and focus. In particular, we will continue to utilize and expand the following aspects of the project highlighted by reviewers, if possible: (1) use of the industry advisory panel, (2) alignment/collaboration with biomass conversion projects, (3) open-source code and tech transfer mechanisms, (4) emphasis on capturing biomass complexity in scalable models, and (5) study of zeolite catalysis transport and deactivation mechanisms.

The reviewers also offered some constructive criticism and potential new areas of research that the CCPC has considered for future direction. Responses to specific comments are as follows:

- Regarding transfer of methodologies and models and potential commercial partners for transfer: While some modeling in the project is using commercial software, many efforts in the project utilize open-source and/or publicly available software (e.g., MFIX). In addition, the CCPC publishes methodologies in peer-reviewed journals and presents at public conferences; we also post a significant amount of our code as open source on GitHub and on our CCPC website. We agree that transfer of models to specific commercial partners may present a good opportunity for improving transfer and utility of CCPC models, and the CCPC will investigate that opportunity.
- Regarding expanding scope to include separations: While collaborating projects or industry advisors have not requested separations modeling to date, the CCPC considers this an interesting opportunity and will begin discussions with the relatively new BETO Separations Consortium to determine what challenges could be aided by modeling.
- Regarding tangible benefits to and support of technical projects in program: Yes. In many cases, we are already in the process of transitioning from model development to industry-relevant technical project support. Such efforts are focused during our quarterly stakeholder meetings and periodic industry advisory board updates. It is our belief that the current flexible approach allows us to rapidly leverage the broad capabilities across the national laboratory system while maximizing our utility to the core BETO programs/mission.
- Regarding the Davison Circulating Riser: We acknowledge the limitations of the Davison Circulating Riser, but the modeling of two other vastly different scale vapor-phase upgrading reactors greatly mitigates issues with the Davison Circulating Riser for our overall objectives. We plan to focus on those reactors and capturing parameters that need critical consideration for scalability and reactor operations, which, together with our vapor-phase upgrading catalysis activity modeling, translates to yield and commercial relevance.
- Regarding broad project scope and prioritization: Our broad scope is challenging from a prioritization and resource allocation perspective, but we benefit from our role as a centralized hub of conversion program relevance. Our enabling role and structure that encompasses joint and linked collaborative milestones with many projects across the program keeps our priorities focused on critical program needs toward techno-economic analysis and commercial success. In addition, our diverse interdisciplinary team operates more efficiently, which enables acceleration of research progress on complex challenges. We intend to rely on guidance from the Peer Review process, our industry advisory panel, and frequent meetings with experimental project teams to prioritize activities and resources.

DEVELOPMENT AND STANDARDIZATION FOR BIO-OIL CHARACTERIZATION TECHNIQUES

(WBS#: 2.5.2.301)

Project Description

This project began in FY 2014 to address the lack of standard chemical characterization analytical methods for bio-oils. Bio-oils are very complex and present numerous analytical challenges, yet reliable chemical information (quantification of both individual compounds and chemical functional groups) is needed to inform upgrading research and refinery co-processing. In this project, we first determine analysis needs from the bio-energy community. We then develop standard methods to meet these needs, and then subsequently validate these methods via inter-laboratory studies with external partners. Methods that are successfully validated (more than 10% variability) are then shared as laboratory analytical procedures, which are free and publicly available.

Recipient:	National Renewable Energy Laboratory
Principal Investigator:	Jack Ferrel
Project Dates:	10/1/2013–9/30/2017
Project Category:	Ongoing
Project Type:	Annual Operating Plan
DOE Funding FY 2014:	\$498,574
DOE Funding FY 2015:	\$990,000
DOE Funding FY 2016:	\$1,000,000
DOE Funding FY 2017:	\$1,000,000

We are also pursuing ASTM standardization to facilitate worldwide adoption of methods standardized in this project. To date, four analytical methods have been standardized: gas chromatography-mass spectrometry, carboxylic acid titration (CAN/TAN analysis), carbonyl titration, and 31P nuclear magnetic resonance. These methods have been published as laboratory analytical procedures and represent the first examples of standard chemical characterization techniques for bio-oils. Furthermore, we are pursuing ASTM standardization with the carbonyl titration method, with widespread participation from the international bio-oil community. This

Weighted Project Score: 7.9

Weighting: For ongoing projects, there is equal weighting across all four evaluation criteria: Approach, Relevance, Accomplishments and Progress, and Future Work.

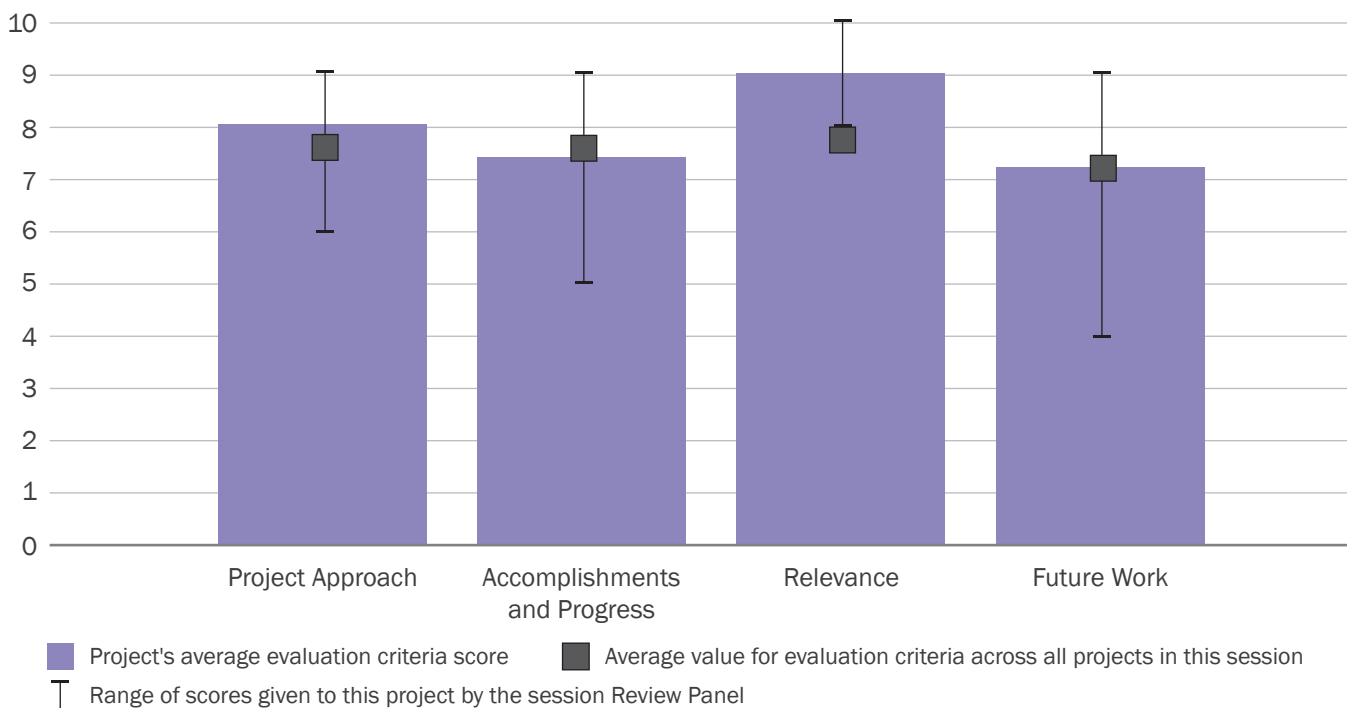

work is meeting the analysis needs of the bioenergy community and will ultimately enable the commoditization of bio-oils.

Overall Impressions

- Excellent progress was made by the analysis team in very challenging mixtures coming from bio-oils. The key will be aging understanding for the future to define if stabilization is truly sufficient. Carbonyl titration ASTM standard is a good first step, but the rest of the work needs to be accelerated as it could have substantial impact on conversion teams and their approaches. Simple should be the guide for future methods as actual plants will not be able to routinely run complex methods due to cost of equipment and personnel trained to run such equipment.
- Developing standardized analytical methods is a requirement for commercializing biofuels. It also provides a basis for accurate and independent evaluation of the results between platforms. The time and costs of analytical methods can be a significant part of the experimental program. Developing routine methods that can be used to follow continuous operation is critical.

It is particularly useful to have this work conducted by a national laboratory with independent funding. The results from the study are of very wide application and are costly. It is difficult for developers to afford funding the required effort to develop these methods internally.

One weakness is the failure to include commercial analytical laboratories on the team to speak towards practicality in the real world.

Another is the lack of focus on methods that can be run outside of a sophisticated analytical laboratory. Robust methods are needed for analysis by a small analytical laboratory at the plant location. The speed of the analysis is critical. Feedback is needed as rapidly as possible to guide operations. The potential for same-day turnaround should be a goal.

- This is a well-managed project that provides important standardization for bio-oil analysis. The methods will be validated by round robin test to confirm target accuracy. Extensive contact with bio-oil developers, process designers, users, etc. is important to ensure that the standardized analysis methods include all the parameters that will be needed for sizing and construction materials selection of equipment handling bio-oil in future integrated biorefineries.
- Overall, this is a very logical and timely project. The approach is pragmatic, and this work should be prioritized, given its value to the biofuels/bioenergy industry. It is critically important that this effort does not call pyrolysis liquid an oil or try to build the new ASTM specs on older ASTM specs associated with oil. Naming conventions are very important in chemistry, and to the extent that a produced standard is meaningful, consistent, and transferable, as a community of practice we need to stop addressing pyrolysis liquids as bio-oils. This project is strategically positioned to effect that change. Adoption and use of new standards will be more impactful if efforts are made to ensure that commercial laboratories have all available equipment and also a comfort level with what is being proposed. Workshops should be held and commercial laboratories should be approached to solicit their feedback/review.
- Getting detailed, reliable characterization of pyrolysis oil will be a major factor in widespread pyrolysis oil acceptance. I'm not convinced the right methods were selected for investigation.

PI Response to Reviewer Comments

- Thank you very much for the comments. We will get feedback from commercial analytical laboratories moving forward, and we have already begun this process. We have also emphasized simple analytical methods in our work, and our two most

reliable methods are titrations with quick turnaround times. Furthermore, our development of a new carbonyl titration method not only resulted in a more accurate method, but cut down analysis time from 24 hours to 2 hours. This method has been used to successfully predict plugging during high-temperature hydrotreatment of raw pyrolysis liquids. We are currently using this method to develop a new aging test, as previous aging tests based on the viscosity measurement were unreliable.

While we have emphasized simple and quick analytical techniques, we have also pursued more advanced techniques, such as chromatography and nuclear magnetic resonance. These methods are widely

used by the research community, and researchers also benefit from analytical standardization. Standardization of these advanced techniques will allow for detailed comparisons between different pyrolysis samples, and these comparisons are critical to inform R&D across the pyrolysis platform. As this project serves the needs of both the research community as well as the emerging pyrolysis industry, we have chosen to pursue analytical standardization of both simple and more advanced techniques. Finally, we agree that bio-oil is neither a descriptive nor accurate name, and we plan to identify a better naming convention and encourage the community to use it.

CATALYST COST MODEL DEVELOPMENT

(WBS#: 2.5.4.301-2)

Project Description

The goal of the Catalyst Cost Model (CCM) project is to develop a catalyst cost estimation tool to enable rapid and informed cost-based decisions in early-stage research and commercialization of catalysts. Prior to the creation of the CCM, an integrated tool for assessing the economic considerations of catalyst development and manufacture was not available. However, for many biomass conversion processes in the BETO portfolio that rely on catalysis, sensitivity analyses have identified that catalyst cost is a major contributor to the MFSP and significantly affects the overall process economics of the integrated biorefinery.

The CCM tool is a first-of-its-kind publicly available tool for determining the costs of precommercial catalysts, paving the way for faster commercialization

Recipient:	National Renewable Energy Laboratory, Pacific Northwest National Laboratory
Principal Investigator:	Frederick Baddour
Project Dates:	10/1/2015–10/1/2018
Project Category:	Ongoing
Project Type:	Annual Operating Plan
DOE Funding FY 2014:	\$0
DOE Funding FY 2015:	\$0
DOE Funding FY 2016:	\$300,000
DOE Funding FY 2017:	\$300,000

of catalytic materials. By employing state-of-the-art estimation methods coupled with an intuitive user interface and comprehensive visualization tools, the CCM tool simplifies the process of assembling cost estimates for precommercial catalysts. This information enables researchers to (1) focus R&D efforts on areas of greatest cost, (2) make informed decisions based on performance per dollar, and (3) guide catalyst synthesis early in development. An industrially reviewed prototype of the CCM tool has been developed with an initial focus on

Weighted Project Score: 8.2

Weighting: For ongoing projects, there is equal weighting across all four evaluation criteria: Approach, Relevance, Accomplishments and Progress, and Future Work.

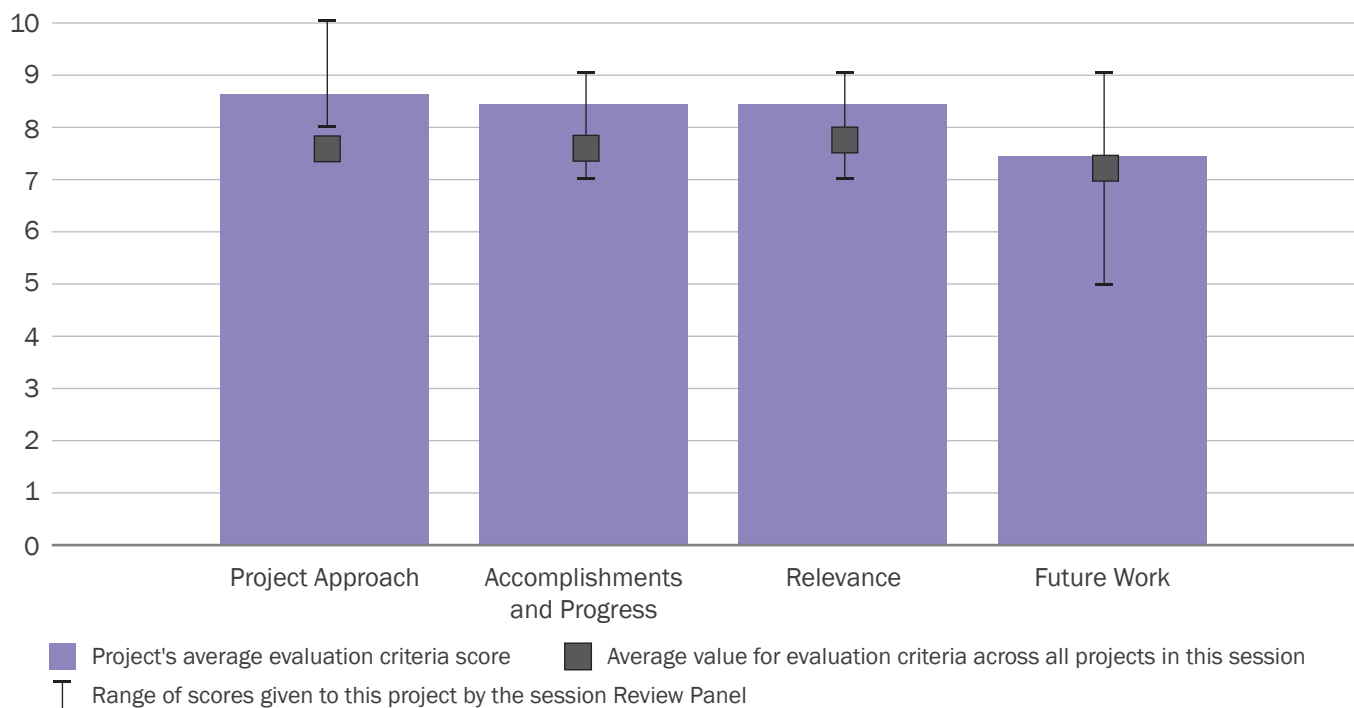

raw materials costs and has been successfully employed to assess the value proposition of catalysts currently under development in the core catalyst projects.

Overall Impressions

- Team organization, feedback from industrial experts, and initial progress is impressive and commendable. Tools such as this are needed for both internal BETO use as well as external use since catalysts are such a key factor in the initial development for biomass conversion technologies versus mature industries.
- Developing a shared tool for estimating the cost of a catalyst will be a major advance for all chemical catalyst research. It will help to guide groups new to catalyst commercialization. Understanding the cost of a catalyst is a vital part of developing economic models for the different processes. It can help guide future work in an area. The work so far has shown clear examples of the impact of catalyst cost on the TEA for an ex-situ catalytic fast pyrolysis case study. The validity of the model has not been proven. It would be worth trying to estimate the cost of some commercially available catalysts as a test.
- The project appears well-organized and will provide a valuable tool for estimating consistent costs of precommercial catalysts to be used in techno-economic analysis at the early stage of various bioenergy process schemes. I strongly recommended including industrial partners in the project for estimating the expected cost of commercially manufactured catalysts, as such cost may be substantially lower than the estimated precommercial catalyst cost.
- Overall, this is a great project that should be given a high priority and more support to accelerate its progress. Going into a commercial venture without truly understanding many of these catalyst cost

variables has resulted in the failure of a number of promising young companies. Additionally, lack of this knowledge also encourages a lot of ideas that should not have been pursued in the first place, wasting time and money. The level of general misunderstanding regarding catalyst production, cost, regeneration, and recycling is staggering, and this project has already made significant gains towards addressing those issues. This is hugely valuable not only to ChemCatBio consortium projects, but also to the public bioenergy/biofuels community.

- This is an impressive effort. As a catalyst researcher, this tool would be very useful in the Stage 1–2 (stage-gate terminology) project phase, where approaches are being evaluated and lead concepts being selected. I look forward to seeing the outcome.

PI Response to Reviewer Comments

- We appreciate the reviewers' helpful suggestions on ways to improve our project. We agree that establishing the validity of the methods we are building into the catalyst cost estimation tool will be critically important to a successful deployment. We are actively evaluating a series of commercially available industrial catalysts using our cost estimation methodology to benchmark the accuracy of the tool.

We have targeted industrial catalysts for benchmarking that are manufactured differently (e.g., zeolite crystallization, wet impregnation, metal salt precipitation) to identify areas of our operating cost estimation methodology that accurately reproduce the manufacturing costs of these catalysts and areas of weakness that need further refinement to reach agreement with the costs of these commercial catalysts. Upon completion of this internal validation, we will submit our validation strategy to our industrial reviewers for assessment to ensure that our benchmarking approach is appropriate and that the results it generates are meaningful.

We thank the reviewers for their helpful comments on the importance of leveraging industrial partners during the development of our catalyst cost estimation tool. We agree that insight from the catalyst manufacturing sector is crucial to ensuring our tool is able to generate catalyst manufacturing cost estimates that are aligned with the realities of the industry, and we are actively seeking industrial input and working towards increasing the size and scope of our industrial review board.

ADVANCED CATALYST SYNTHESIS AND CHARACTERIZATION

(WBS#: 2.5.4.303-5)

Project Description

The Advanced Catalyst Synthesis and Characterization (ACSC) project delivers high-performance cost-effective catalysts that meet the needs of the ChemCatBio catalysis projects by leveraging advanced characterization capabilities and synthesis expertise at DOE national laboratories. The ACSC is based on a successful collaboration between Argonne National Laboratory and the National Renewable Energy Laboratory, in which X-ray absorption spectroscopy coupled with experiment identified active sites responsible for the enhanced performance of a Cu-zeolite catalyst for the dimethyl ether-to-hydrocarbons pathway. As the ACSC, this collaborative effort was expanded to encompass X-ray absorption spectroscopy at Argonne National Laboratory, sub-Angstrom resolution electron microscopy at Oak Ridge National Laboratory, and a dedicated synthetic

Recipient:	National Renewable Energy Laboratory, Argonne National Laboratory, Oak Ridge National Laboratory
Principal Investigator:	Theodore Krause
Project Dates:	10/1/2016–9/30/2019
Project Category:	New
Project Type:	Annual Operating Plan
DOE Funding FY 2014:	\$0
DOE Funding FY 2015:	\$0
DOE Funding FY 2016:	\$0
DOE Funding FY 2017:	\$900,000

effort at the National Renewable Energy Laboratory focused on developing next-generation catalysts through innovative synthetic routes. This integrated approach enables the ACSC to (1) identify active site structures in working catalysts, (2) inform computational models to predict structures with enhanced performance, and (3) deliver next-generation catalysts that exceed performance targets. This accelerated catalyst development cycle will be demonstrated by developing a predictive model for zeolite catalyst deactivation that minimizes carbon lost to coke, as well as tailored multi-metal

Weighted Project Score: 7.4

Weighting: Approach–25%; Relevance–25%; Future Work–50%.

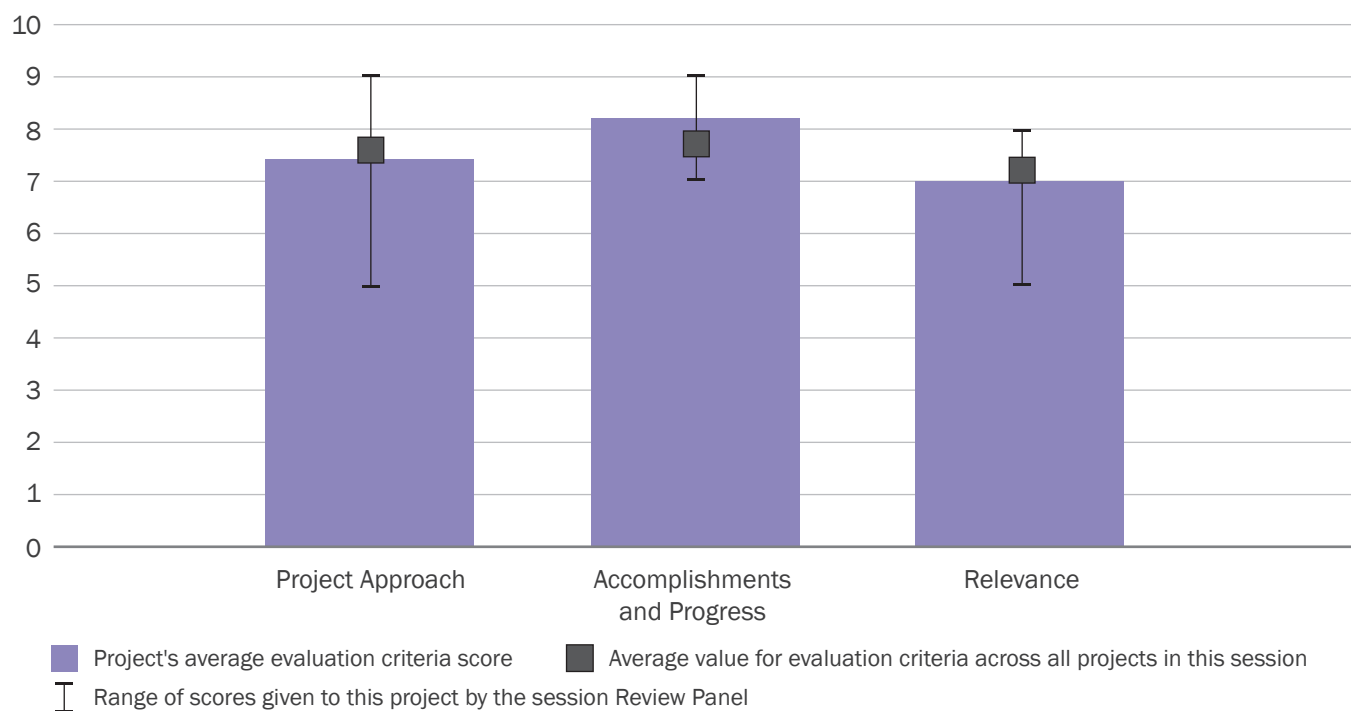



zeolites to increase the yield of jet fuel from dimethyl ether by 1.5-fold, leading to reduced conversion costs for biomass processes.

Overall Impressions

- The team has done good job in a very difficult area of work, i.e., designing new catalyst systems for such complex processes. This work is highly relevant to the program as some standard catalysts have not functioned well on biomass, and clearly sulfur tolerance and coking are key areas to improve on with new catalysts. The key will be focusing on the right catalyst-process combination with other teams to provide the biggest impact since the team cannot work on improving all the slate of catalysts being explored by the teams and processes.
- I did not see much emphasis on the catalyst synthesis and preparation portion of the project. The ability to obtain sufficient amounts catalysts has hindered several programs. I believe the team has the ability to scale up catalyst production to meet the needs of the larger-scale equipment currently being developed in the national laboratories. Larger-scale preps are needed for multiple experiments and comparisons.

The characterization tools available are impressive and will be useful to any catalyst development effort. Offering access to these to outside groups would facilitate development efforts.

It would be worthwhile to develop a relationship with the high-field mass spectrometry group in Florida. There is a lack of sophisticated techniques for organic compound identification in the program.

- The project effort is leveraging the expertise and knowledge available at several national laboratories. I strongly recommend that the activities under this project are limited to evaluation and identification of special catalytic needs for the BETO programs, and that the actual final catalyst formulation and manufacture of such new catalysts are outsourced to commercial catalyst companies who already have these types of skills and experience. By doing so, the commercialization of the new catalysts will be accelerated. I therefore recommend that the team get industry partners with experience in catalyst development and manufacturing more directly involved, when it comes to the manufacturing step of the project.
- Overall, this project has a lot to offer ChemCatBio and is a very straightforward and fundamentally important component of the consortium. It is important that every project associated with ChemCatBio has access to standardized analysis and post-mortem characterization, as that is often the only way to make sure everyone is speaking the same language. Major focus should be on supporting consortium project analysis and characterization needs, rather than novel catalyst development, but clearly, where opportunities present themselves (such as metallic and ionic Cu work), work should be completed. Post-mortem analysis of commercial catalysts that have been utilized under various relevant bioenergy/biofuels process conditions is critically important to directing industrial partners on how to improve their products.
- If successful, I think this project, along with the other enabling projects, has the potential to lead to significant advances in understanding the catalytic conversion of biomass oxygenates. I strongly support resources directed to this activity.

PI Response to Reviewer Comments

- We appreciate the positive feedback from the reviewers regarding the successful design of new catalyst systems for complex conversion processes,

the relevance of this work to the overall program, and the fundamental importance of catalyst characterization and development to the ChemCatBio consortium and scientific community.

In response to the comment on our level of emphasis on the catalyst synthesis portion of the project, we envision two critical roles for catalyst synthesis within the ACSC. The first is as an integral part of the advanced characterization effort. In this capacity, we have shown that for a technical Cu-zeolite catalyst, which contains multiple potential active sites, we can synthesize model catalysts containing only one of each type of active site. Evaluation of these model catalysts by the collaborating catalysis group and advanced characterization by the ACSC established which active site was responsible for the targeted transformation. This information enabled the development of an active site model by the Consortium for Computational Physics and Chemistry, which led to the prediction of next-generation catalyst development targets. The second role for catalyst synthesis within the ACSC is to prepare these predicted catalyst targets using controlled synthesis techniques to confirm and understand performance improvements enabled by the catalyst development cycle. As a new start project in FY 2017, we have not yet proven our approach on multiple efforts, but we have presented the Cu-zeolite case as an example that demonstrates the critical role of the ACSC in the catalyst development cycle.

With regards to the scale of catalyst synthesis, although our team generally prepares catalysts on a 1–100-g scale, which is suitable for many of the reactors available within ChemCatBio, we have previously worked with industrial partners to increase the scale of catalyst synthesis beyond this development level. We appreciate the reviewer's suggestion that we involve catalyst production experts, potentially in collaboration with a national laboratory effort, in early-stage catalyst development in order to understand the requirements of larger-scale catalyst

design. We will also consider adding a task within the ACSC dedicated to catalyst scale-up.

We agree with the reviewer that the tools and methodologies being developed within the ACSC will be useful to external catalyst development efforts, and consequently, we have placed a high priority on the publication of our results to make them available to the scientific community. Additionally, many of the capabilities are part of DOE user facilities, and we will consider how best to work with external partners as we move forward with the ChemCatBio consortium. Energy Materials Network consortia, like ChemCatBio, are focused on engaging with industry, and therefore, the guidance from the reviewer integrates well with the ChemCatBio mission.

We agree that organic compound identification is an important part of understanding deactivation by coke formation, for example. Currently, we are using nuclear magnetic resonance techniques and in-situ thermogravimetric analysis with infrared spectroscopy analysis of volatilized species to identify organic functionalities that can be removed from the spent catalysts chemically or thermally, as well as species that remain within the catalysts. We appreciate the suggestion to consider mass spectrometry as a complementary method for organic compound identification.

We thank the reviewer for the comments and agree that we need to identify the most important catalyst-process combinations to provide the greatest impact to the ChemCatBio catalysis projects. One way we are seeking to do this is by identifying overarching challenges, such as zeolite deactivation, that are relevant to multiple conversion processes. Once we have developed the characterization methodologies and models through the Consortium for Computational Physics and Chemistry, we can more efficiently evaluate the impact of the different conversion processes, reactor scales, and catalyst features on deactivation.

FRACTIONATION AND CATALYTIC UPGRADING OF BIO-OIL

(WBS#: 2.5.4.401)

Project Description

The goal is to develop a biomass conversion process that optimizes fractionation and conversion to maximize carbon efficiency and hydrogen consumption to obtain drop-in fuels. The team obtained selective fractionation of raw biomass via multi-stage thermal fractionation to produce different streams that are enriched in a particular chemical family (acids, furanics, or phenolics). These streams were later catalytically upgraded in both liquid or vapor phase to perform C-C bond formation and hydrodeoxygenation. Among various upgrading strategies investigated, we have identified an effective path in which cyclopentanone is a crucial intermediate that can be derived from furfural and other furanics obtained in high concentrations from this thermal staged process. Cyclopentanone is a very versatile molecule,

Recipient:	University of Oklahoma, Idaho National Laboratory
Principal Investigator:	Daniel Resasco
Project Dates:	9/30/2013–3/31/2017
Project Category:	Sun-setting
Project Type:	FY 2013–CHASE: DE-FOA-0000812
Total DOE Funding:	\$2,393,370
DOE Funding FY 2015:	\$0
DOE Funding FY 2016:	\$0
DOE Funding FY 2017:	\$900,000

which can couple with itself to produce high-quality jet fuel, or couple with phenolic or furanics to create long chain molecules. These (still oxygenated) compounds can be hydrotreated to direct drop-in fuels. Interestingly, we have found that the conversion of furfural to cyclopentanone is not affected by acetic acid, and, more importantly, it is enhanced by water. These are very significant findings, since water and acetic acid are always present in all streams. These results have allowed detailed life-cycle analysis and techno-economic anal-

Weighted Project Score: 7.0

Weighting: Approach–25%; Relevance–25%; Future Work–50%.

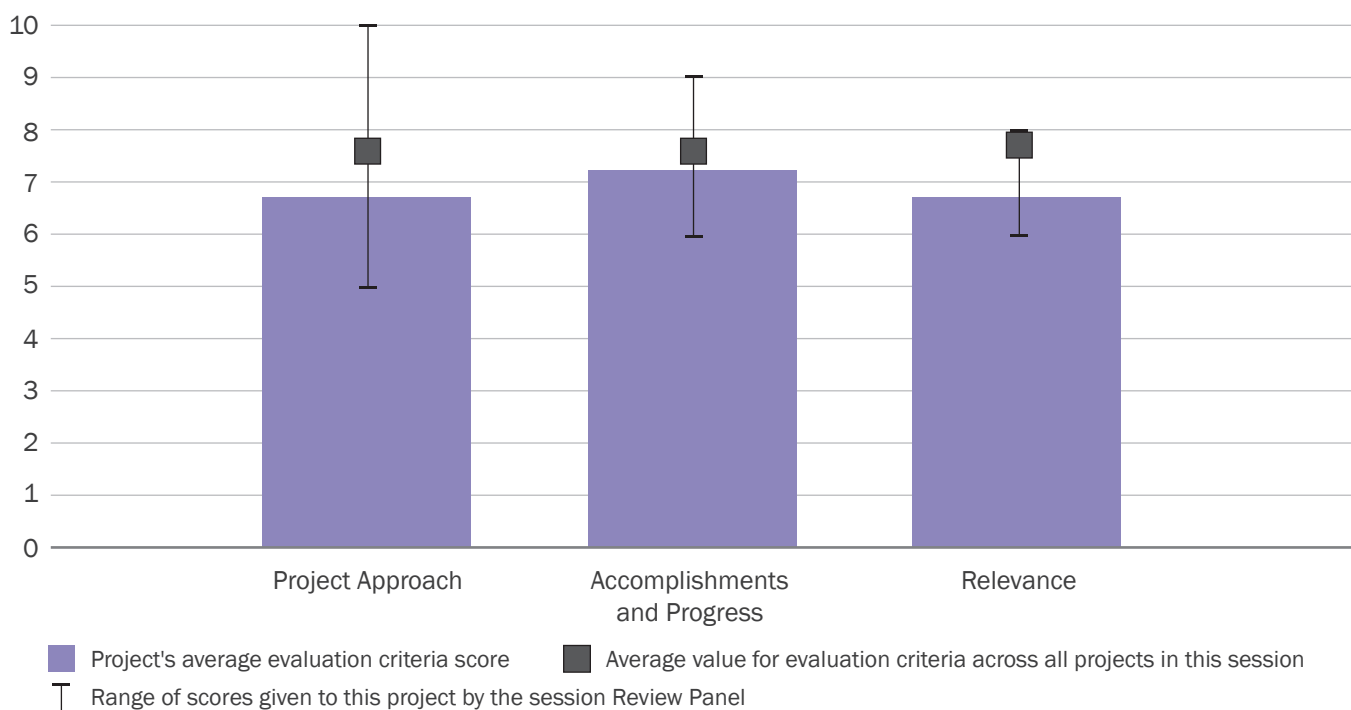

ysis studies that are back-fed to the experimentalists to refine the catalyst selection and process operations with the objective of maximizing C efficiency at minimum H utilization.

Overall Impressions

- This project explores some fundamental chemistry of the major components obtained by thermal deconstruction of biomass at different temperatures. The work provides important data and has illustrated new chemistry and, as such, is a success. The commercial framework proposed and techno-economic analysis are less impressive due their complexity. It was difficult to follow the cost comparison and overall carbon retention.
- This is an interesting concept that seems a little more theoretical than practical. It still needs more optimization to reduce complexity and capital expenditure.

- Overall, this is a very compelling project that showed the value of staged pyrolysis and explored downstream acylation reactions as a way to combine and valorize multiple product streams. Significant work remains to scale up conversions and consider economics, but this is a very strong start down a promising and logical path. By targeting two of the most abundant products from the staged pyrolysis, this project is working with thermodynamics instead of fighting it. This is relevant because these design decisions will ultimately lead to higher efficiencies, better separations, and improved economics.
- This project focused on basic conversion pathways for biomass-derived oxygenates. This is interesting from a fundamental chemistry perspective, which remains a gap for biomass upgrading to fuels and chemicals.

PI Response to Reviewer Comments

No official response was provided at the time of report publication.

NOVEL ELECTRO-DEOXYGENATION PROCESS FOR BIO-OIL UPGRADING

(WBS#: 2.5.4.403)

Project Description

Lignocellulosic biomass residue, such as agricultural and forestry residue, can be converted to liquid fuels via bio-oil production by fast pyrolysis. The high oxygen content and instability of bio-oil poses a challenge for its practical use. The conventional approach to deoxygenate and stabilize bio-oil is the hydrodeoxygenation process, which requires a large volume of hydrogen and is amenable to only centralized processing. Typical bio-oil is biphasic, and only the organic phase is processed in subsequent upgrading steps, leaving behind valuable carbon-containing material in the aqueous phase. This project investigates a novel electro-deoxygenation process using a solid-state ceramic device. Deoxygenation of model compounds and aqueous phase of pine wood bio-oil has been tested using oxygen ion-conduct-

Recipient:	Ceramatec
Principal Investigator:	Elango Elangovan
Project Dates:	9/30/2013–9/13/2016
Project Category:	Sun-setting
Project Type:	FY 2013–CHASE: DE-FOA-0000812
Total DOE Funding:	\$2,604,152

ing, ceramic membrane-based, electrochemical cells operated in the temperature range of 500°–600°C. The product from the electrochemical cell contained a suite of compounds with significantly lower oxygen content. An integrated test of an electrochemical stack with a slip stream of pyrolysis vapor showed that the product is significantly different from unprocessed bio-oil in terms of functional groups. An additional integrated test of longer duration is planned to fully characterize the electro-deoxygenation product. Life-cycle analysis, supply chain logistics, and techno-economic process models are underway.

Weighted Project Score: 5.7

Weighting: Approach–25%; Relevance–25%; Future Work–50%.

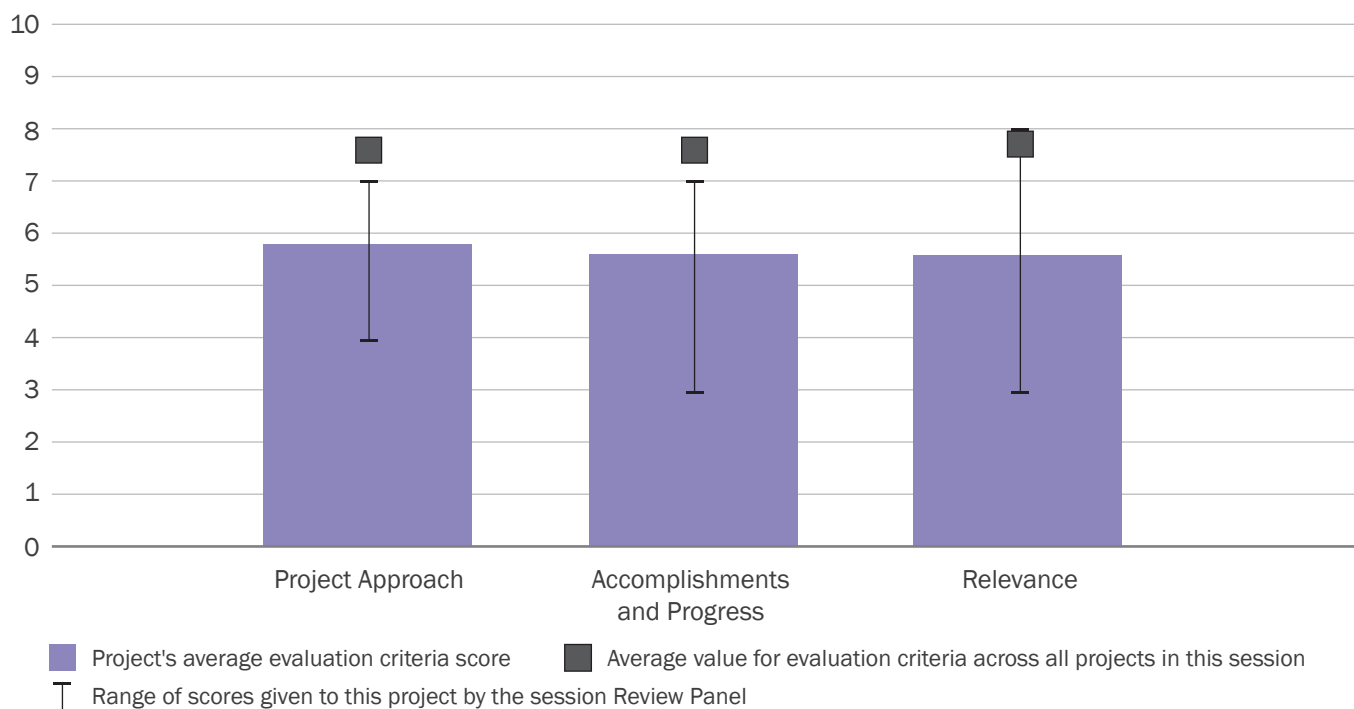

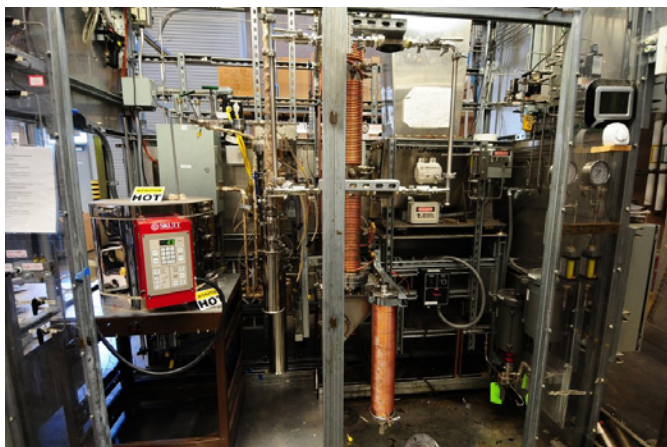

Overall Impressions

- This project has too many concerns and issues to be relevant for BETO goals. There are other ways to generate hydrogen for processing. I do not see proof that the system really is doing more than further temperature pyrolysis, as acid is also present in substantial amount via water phase in a two-phase system. Also, this is a costly approach due to ceramic equipment, which was not provided, but I expect it will have high capital expenditure for large unit ops.
- This project was a success in that it evaluated an electrochemical and membrane approach to upgrading biomass-derived liquids without hydrogen. BETO should be commended for including these types of projects in its portfolio. Unfortunately, the results of the experiment did not show commercially relevant conversion was possible. This may rule out ceramic membranes for use in this application.

The concept of using renewably generated electricity to produce biofuels as a method of storing energy is very relevant. However, it couples the costs of the two processes, which complicates evaluation.

- This is an interesting project using reverse solid-oxide fuel cell (SOFC) technology. Reverse SOFC must operate at lower temperature than SOFC, which will reduce efficiency. It may therefore be an expensive alternative as SOFC is expensive technology.

- Overall, this is an intriguing new application of solid-oxide electrochemical processes. An important issue is that the standard of measure is H₂ hydrogenation, which will almost certainly never be a commercial reality at any significant scale. It is also widely accepted that water hydrolysis is a more expensive way to generate H₂ at scale than steam reforming. However, one of the more interesting developments in this work is the preference for methoxyls over hydroxyls. If this process can be utilized to efficiently remove certain functional groups and support targeted decomposition reactions, it could play an important role in other downstream processing/refining challenges.
- This is an interesting idea that has not generated technical results of sufficient quality to evaluate thoroughly. Process robustness is a major concern.

PI Response to Reviewer Comments

- “The experiment did not show commercially relevant conversion was possible. This may rule out ceramic membranes.”

This is a feasibility demonstration project, and many of the shortcomings identified need to be addressed. One such shortcoming is the performance of the electrochemical device. We used the materials set that was developed to operate at 800°C to establish the process feasibility at 600°C or below. Further improvement in performance of the device is clearly required to show commercially relevant conversion. Several major activities are currently underway to improve stack performance such that the present 800°C capability can be achieved at 600°C or below. Furthermore, the life-cycle analysis that is ongoing may show that partial deoxygenation has better economics and lower emissions than full deoxygenation. In that case, the performance improvements required may be moderate.

- “It couples the costs of the two processes (deoxygenation and renewable energy), which complicates evaluation.”

We do not anticipate co-locating renewable energy generation and pyrolyzer. The grid mix in certain areas (e.g., the Pacific Northwest) uses more renewable, and locating pyrolyzer–electro-deoxygenation in such locations will reduce greenhouse gas emissions. The inherent use of low to no hydrogen in this process will also offset greenhouse gas emissions from steam reforming to produce hydrogen.

- “There are other ways to generate hydrogen. I do not see proof that the system really is doing more than further temperature pyrolysis. Also, this is a costly approach due to ceramic equipment, which was not provided, but I expect it will have high capital expenditure for large unit ops.”

There are other ways of producing hydrogen. However, the cost of compression and transportation is a large factor in hydrogen cost as hydrogen is less likely to be economical to produce in a distributed manner, as the pyrolysis units would require. The electricity is more widely available as a substitute for hydrogen in this process. This approach also eliminates the difficulty in storing and transporting unstable pyrolysis oil to a downstream processing facility.

Per Pacific Northwest National Laboratory’s experience, higher-temperature fast pyrolysis will produce a different product, and it will be somewhat more deoxygenated and with lower yield of liquid; this can even change it enough to force the phase separation of an aqueous layer. Tests done at Pacific Northwest National Laboratory in the 1980s at 650°C have shown that effect. However, the difference at 550°–600°C would not be as great as was found with electro-deoxygenation.

The cost of the ceramic equipment is a concern. We will be doing a preliminary cost estimate and performing a trade study of performance required and capital cost to supplement the life-cycle analysis.

- “It may therefore be an expensive alternative, as SOFC is expensive technology.”

We agree that cost is a concern. The energy required to remove oxygen at the lower temperature will be more than that needed at the higher temperature. However, based on life-cycle analysis to date, the significant reduction in the required hydrogen may offset the higher capital cost. As another reviewer pointed out, hydrodeoxygenation is “inefficient” and “hydrogenation will almost certainly never be a commercial reality at any significant scale.” This project is aimed at demonstrating the technical feasibility of an alternative approach and evaluating its economic feasibility.

- “If this process can be utilized to efficiently remove certain functional groups and support targeted decomposition reactions, it could play an important role in other downstream processing/refining challenges.”

We appreciate the suggestion. While beyond the scope of the project, it can be envisioned that by introducing additional catalysts in the electrode, more specific functional groups can be removed and formed to make the process more compatible with downstream processing.

- “Process robustness is a major concern.”

The team shares the concern about process robustness. The next experiment at Pacific Northwest National Laboratory will operate the integrated unit for a longer duration to understand the process stability and device robustness.

IMPROVED HYDROGEN UTILIZATION AND CARBON RECOVERY FOR HIGHER-EFFICIENCY THERMOCHEMICAL BIO-OIL PATHWAYS

(WBS#: 2.5.4.405)

Project Description

This project focuses on the potential for improved hydrogen utilization and carbon recovery in a novel, direct biomass liquefaction process. The primary objective is to use hydrogen during in-situ catalytic biomass pyrolysis to maximize the biomass carbon and energy recovery in a low-oxygen-content, thermally stable biocrude intermediate that can be efficiently upgraded into a finished biofuel. The secondary objective is to improve the carbon efficiency of the integrated process by converting the carbon in the aqueous stream to methane for hydrogen production. New and novel catalysts are being developed to improve hydrodeoxygenation during cata-

Recipient:	Research Triangle Institute
Principal Investigator:	Dave Dayton
Project Dates:	9/1/2014–12/31/2017
Project Category:	Ongoing
Project Type:	FY 2013—CHASE: DE-FOA-0000812
Total DOE Funding:	\$3,140,526
DOE Funding FY 2015:	\$0
DOE Funding FY 2016:	\$0
DOE Funding FY 2017:	\$900,000

lytic biomass pyrolysis to reduce biocrude oxygen content, reduce char formation, and subsequently improve hydrogen utilization during biocrude upgrading. We are evaluating anaerobic digestion for aqueous-phase carbon conversion to methane that can be reformed for hydrogen production.

Overall Impressions

- This is a well-managed and well-run project providing details and clear goals and accomplishments. The team is to be commended. I see no issues or

Weighted Project Score: 7.5

Weighting: For ongoing projects, there is equal weighting across all four evaluation criteria: Approach, Relevance, Accomplishments and Progress, and Future Work.

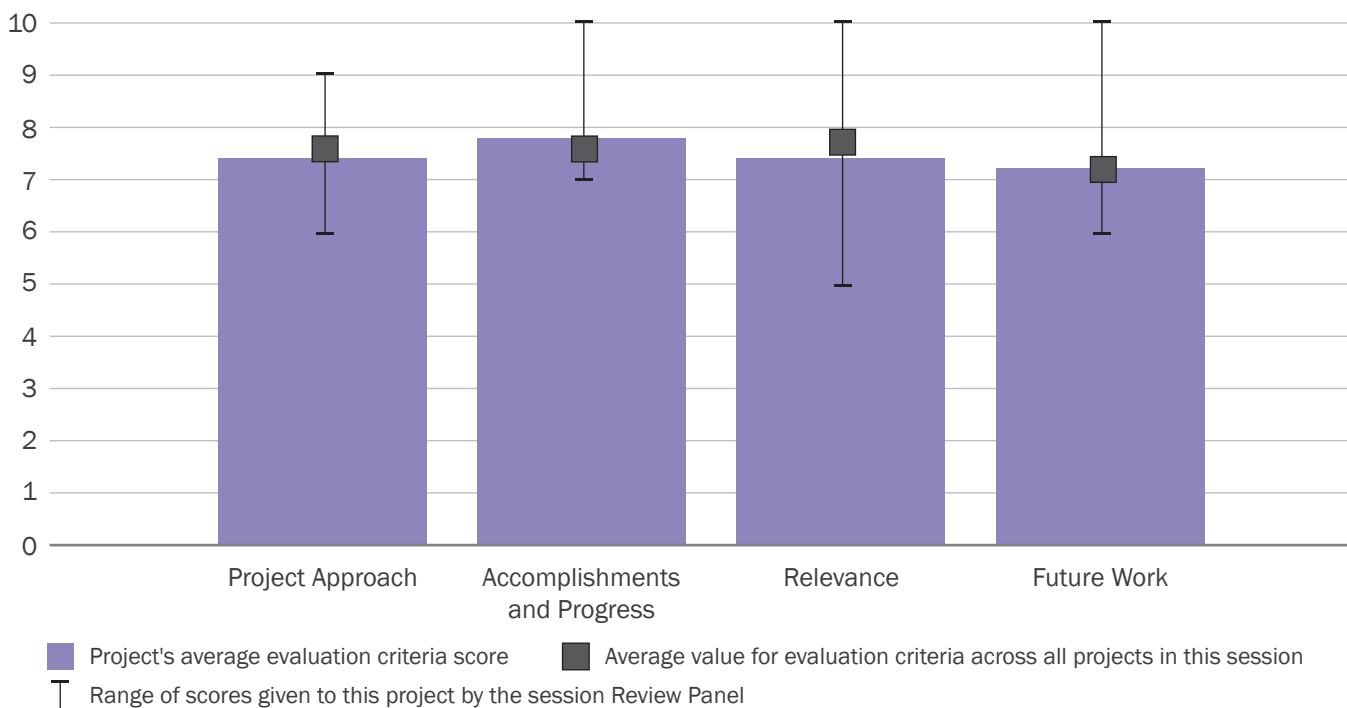



concerns other than catalyst lifetime, which will be worked on in phase 2.

- This is a very interesting project; however, it is basically integrated hydro-pyrolysis plus hydroconversion technology (IH₂) “light.” It confirms the benefit of using a hydrogen transfer catalyst and added hydrogen on retention of carbon during pyrolysis. However, IH₂ has already demonstrated this fact. The unique feature in this approach is lower-pressure operation. The anaerobic digester work shows the potential of this technique to produce hydrogen for the process. However, there are still concerns about the toxicity of the feed. The long time scale needed to condition the microbes will be a significant operational constraint.
- This is a good project for a highly integrated technology, which results in a more efficient process scheme. Techno-economic analysis will confirm if the integrated process is competitive (high capital cost?).

- Overall, this is a solid project that contributes to a growing portfolio of fast pyrolysis reactors capable of running under H₂ atmosphere. That said, at commercial scales, even if the hydrogen comes from light gases produced *in situ*, natural gas steam-methane reforming will be more economic and financeable. Furthermore, it is widely known that high H₂ partial pressures reduce coking and increase liquid yields. So, it is not clear how this project has advanced the state of the art in that regard. An expanded look at carbon efficiency versus realistic product value needs to take place, starting with a close look at “where” carbon efficiency should take place (based on what has been learned in the last 10 years of pyrolysis research). If the objective is to convert the pyrolysis liquid into a fuel blendstock outside of a refinery, the most economical way to do this is the removal of oxygen, not through hydrogenation, but through staged pyrolysis since the light pyro-gases often contain the most O₂. If the objective is to make value-added chemicals (such as fuel/oil additives) from biomass, then keeping the oxygen and leveraging the reactivity of biomass chemistry to make valuable non-hydrocarbon chemicals makes the most sense. Trying to solve these challenges through brute force H₂ hydrogenation and utilization of catalysts in harsh conditions is unlikely to be constructive in the long term.
- This is an ambitious project, but I’m skeptical that the overall, integrated process for catalytic pyrolysis in the presence of hydrogen will result in improved operability compared with “conventional” catalytic fast pyrolysis.

PI Response to Reviewer Comments

- There is no doubt that hydro-pyrolysis is an effective process for producing a low-oxygen content biocrude with improved yields and reduced char formation compared to catalytic fast pyrolysis; however, we feel that one of the more significant chal-

Challenges for scaling up this technology will be feeding biomass into a pressurized reactor. That said, we are anxiously following the scale-up activities for the IH2 technology.

We are addressing this technical challenge by developing an atmospheric pressure process that utilizes hydrogen in a catalytic biomass pyrolysis process—reactive catalytic fast pyrolysis—yet has comparable biocrude yields and quality to the high-pressure process. There is scant literature detailing the benefits of utilizing hydrogen in biomass pyrolysis at low pressure outside of small microreactor systems and model compound studies. This project aims to fill that technical gap and provide information for hydrodeoxygenation of biomass pyrolysis vapors at the large laboratory and pilot scales.

The reactive catalytic fast pyrolysis process is also integrated with an anaerobic digestion process to investigate the potential of recovering carbon from the aqueous phase and converting it into renewable methane. Anaerobic digestion has been done commercially for decades, but the application of anaerobic digestion to a biomass pyrolysis aqueous stream is unique to this project. In fact, with methane from the anaerobic digestion, no additional fossil hydrogen

is required in the process, ensuring that it meets the 50% greenhouse gas emissions reduction required for advanced biofuels. This opens the possibility of finding alternative uses for the pyrolysis gases.

Initially, the biofuel wastewater was very toxic to the microbes, even at 0.02% addition, by best management practice tests. We have since started very slowly on acclimation, and we have improved the performance significantly—going from zero removal to more than 70% removal and conversion to CH_4 . The innovation is the adaption of the microbial population in the sludge for converting carbon in the aqueous phase containing various organics, many of which can be toxic to anaerobic microorganisms. Future work in the project is focused on improving the carbon conversion in anaerobic digestion using proper pretreatments and process optimization.

Catalyst regeneration during reactive catalytic fast pyrolysis and the safe addition of hydrogen to the 1 ton/day pilot plant remain technical challenges for scaling up the process. We will perform additional laboratory experiments to evaluate the efficacy of other regeneration options and develop a strategy for catalyst regeneration in the pilot plant tests. Efforts are also underway at RTI to produce large quantities of fluidizable and attrition-resistant catalysts.

ADVANCED MEMBRANE SEPARATIONS TO IMPROVE EFFICIENCY OF THERMOCHEMICAL CONVERSION

(WBS#: 2.5.5.301)

Project Description

The objective of the project is to develop and employ robust advanced membranes to improve the efficiency of bio-oil processing. These porous membranes take advantage of surface tunability (from superhydrophilicity to superhydrophobicity) to achieve high permeability while maintaining high selectivity. This effort is relevant to BETO's barriers (Ct-L) Aqueous Phase Utilization and Wastewater Treatment, (Tt-E) Liquefaction of Biomass and Bio-Oil Stabilization, and (Tt-G) Fuel Synthesis and Upgrading. Key challenges are enabling higher flux (at desirable separation factor), improving chemical/thermal stability and fouling resistance, and developing a path forward to a small unit volume but high-productivity membrane module. By September

Recipient:	Oak Ridge National Laboratory
Principal Investigator:	Michael Hu
Project Dates:	10/1/2016-9/30/2019
Project Category:	Ongoing
Project Type:	Annual Operating Plan
DOE Funding FY 2014:	\$500,000
DOE Funding FY 2015:	\$790,000
DOE Funding FY 2016:	\$790,000
DOE Funding FY 2017:	\$715,000

2019, we plan to demonstrate a separation technology to meet performance targets (>1 liter/m²/hour liquid dewatering flux at separation factor >20) and achieve a >8% reduction in MFSP (\$/gge). Over the past 2 years, we have made significant advancements in vapor-phase dewatering and liquid-phase separation technologies. For example, we demonstrated a >5x improvement in the permeation flux for dewatering membranes, which will lead to a more efficient process for recovering carbon from aqueous waste streams. Our work has led to an industry-funded commercialization project that is

Weighted Project Score: 7.5

Weighting: For ongoing projects, there is equal weighting across all four evaluation criteria: Approach, Relevance, Accomplishments and Progress, and Future Work.

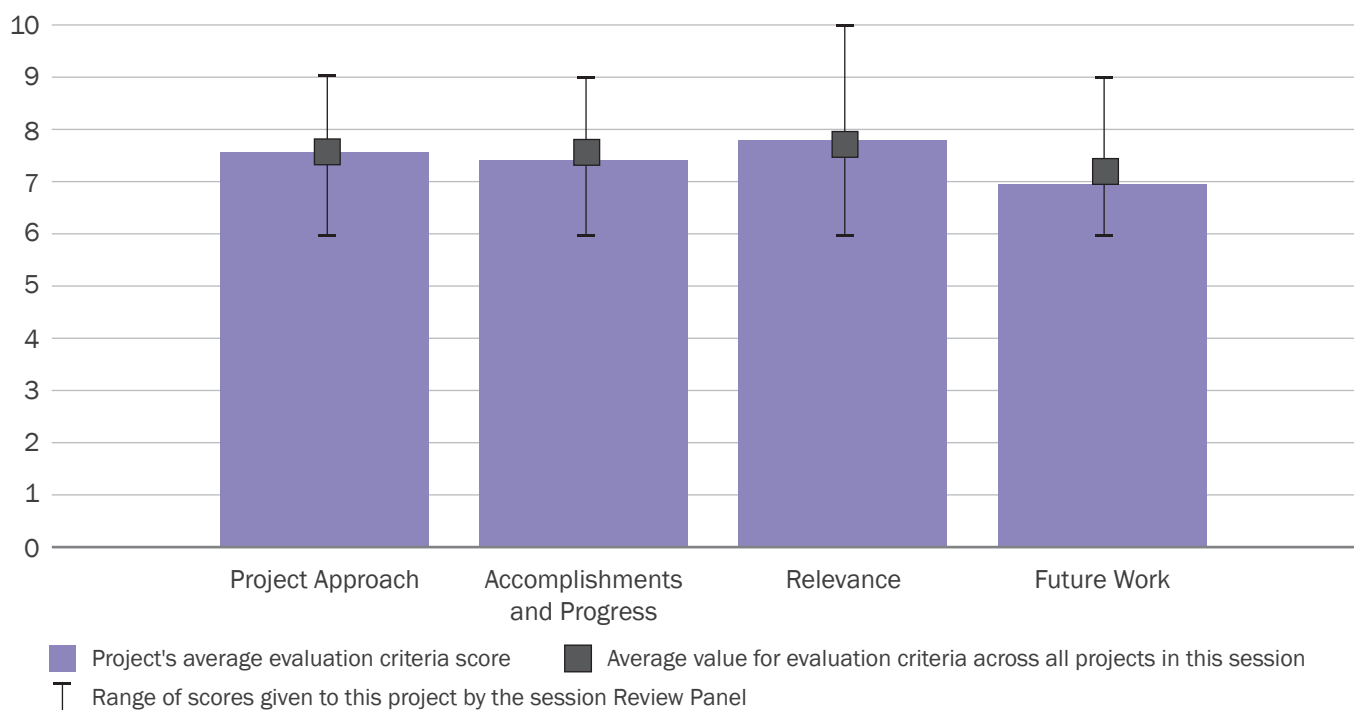

seeking to integrate advanced emulsion separation technologies with biofuel conversion reactors to increase overall production yield.

Overall Impressions

- The key will be long-term continuous operation trials and further improvement of flux via polymer-graphene coated membranes. However, the progress to date is impressive. Future work in 2018 to explore hydrophobic membranes to lower membrane costs and reduce surface area requirements seems a bit counterintuitive, as the team indicated superhydrophilic gave such good results so far. Perhaps the team can explain further the logic behind the shift in future work? I assume the go/no-go decision in 2018 of separation factor >10 and flux of >0.4 liter/m²/hour is for hydrophobic membrane, as superhydrophilic already achieved this result?
- The use of membrane separation of carbon from the aqueous phase is well worth examining. The approach taken by the researchers has one of the best chances of success. They have made major strides in developing a new membrane technology and are using the methods most likely to resist fouling.
- This is an interesting project. The use of membrane is, on the other hand, a challenge due to corrosive and fouling issues.
- Overall, this is a very interesting development. Thermal stability of the hydrophobic and hydrophilic coatings at 250–400°C is very impressive and suggests a wide range of industrial utility. Chemical stability and fouling resistance is also very intriguing given the small particulate often found in pyrolysis liquids. However, it was not clear how these results compared to current commercial acetic acid and vinegar concentration processes, and additional investigation into these comparisons would provide much-needed context for the level of improvement being proposed.

- Dewatering a byproduct stream may be a necessary component for valorization of biomass aqueous phase. But, the cost to benefit will depend on overall process efficiency, not only of the membrane, but also of the upstream and downstream technologies. The team needs to guard against unit proliferation to have any hope of overall economic process.

PI Response to Reviewer Comments

- Most aqueous product streams contain more water than organics; therefore, less membrane surface area is required to permeate the smaller quantity of organics, assuming hydrophilic and hydrophobic membranes have the same flux. However, if the flux of hydrophilic membranes is an order of magnitude higher than hydrophobic membranes, or if they are made from much less expensive materials, then hydrophilic membranes may be the most cost-effective option for streams containing more water than organics. Alternatively, if the aqueous stream contains less water than organics, then hydrophilic membranes may be the best option, although this is not the case for most aqueous product streams.

Traditional separation methods for acetic acid from water include energy-intensive distillation processes. Membrane separations have the potential to improve the energy efficiency of the process. In future work, we will conduct more separation tests to provide better data to improve the techno-economic analysis in order to justify membrane performance and economics.

Regarding dewatering, we agree with the reviewer. Too many downstream upgrading and separation steps will negatively impact economics. Sending the concentrated organics to hydrotreating for fuel production does not require additional equipment, but impact on fuel selling price may not be significant. Thus, converting organics to higher-value chemicals is necessary, but additional costs will depend on conversion performance/selectivity, separation technology, and product selling price.

FRACTIONAL MULTISTAGE HYDROTHERMAL LIQUEFACTION OF BIOMASS AND CATALYTIC CONVER- SION INTO HYDROCARBONS

(WBS#: 2.5.5.401)

Project Description

The purpose of this project is to demonstrate the technical and commercial feasibility of producing distillate fuels from lignocellulosic materials. Virent is developing a novel multistage hydrothermal liquefaction deconstruction process, which will be paired with Virent's BioForming® process to produce advantaged jet fuel and diesel. Previous testing has demonstrated that both fuels meet or exceed specifications for commercial and military use. In addition to Virent, the project is leveraging expertise of Idaho National Laboratory for the procurement, pre-conversion, and analysis of woody biomass and corn stover. Since its inception in Quarter 4 of 2013, the project has progressed through TRL 2

Recipient:	Virent Inc.
Principal Investigator:	Randy Cortright
Project Dates:	10/1/2013–9/30/2016
Project Category:	Sun-setting
Project Type:	FY 2013–CHASE: DE-FOA-0000812
Total DOE Funding:	\$3,400,000

and completed design, construction, and operation of a pilot unit to demonstrate the hydrothermal liquefaction process. In Quarter 1 of 2016, the project went through a formal stage-gate review to evaluate progress on milestones. The progress and the current status of the project will be detailed during the review.

Overall Impressions

- This is a nice bit of demonstration at pilot-scale work, in terms of biomass to end product fuel. However, project results fell short of the goals and needs for the BETO program. The techno-economic analysis is hard to understand as there was no real

Weighted Project Score: 7.2

WWeighting: Approach–25%; Relevance–25%; Accomplishments and Progress–50%.

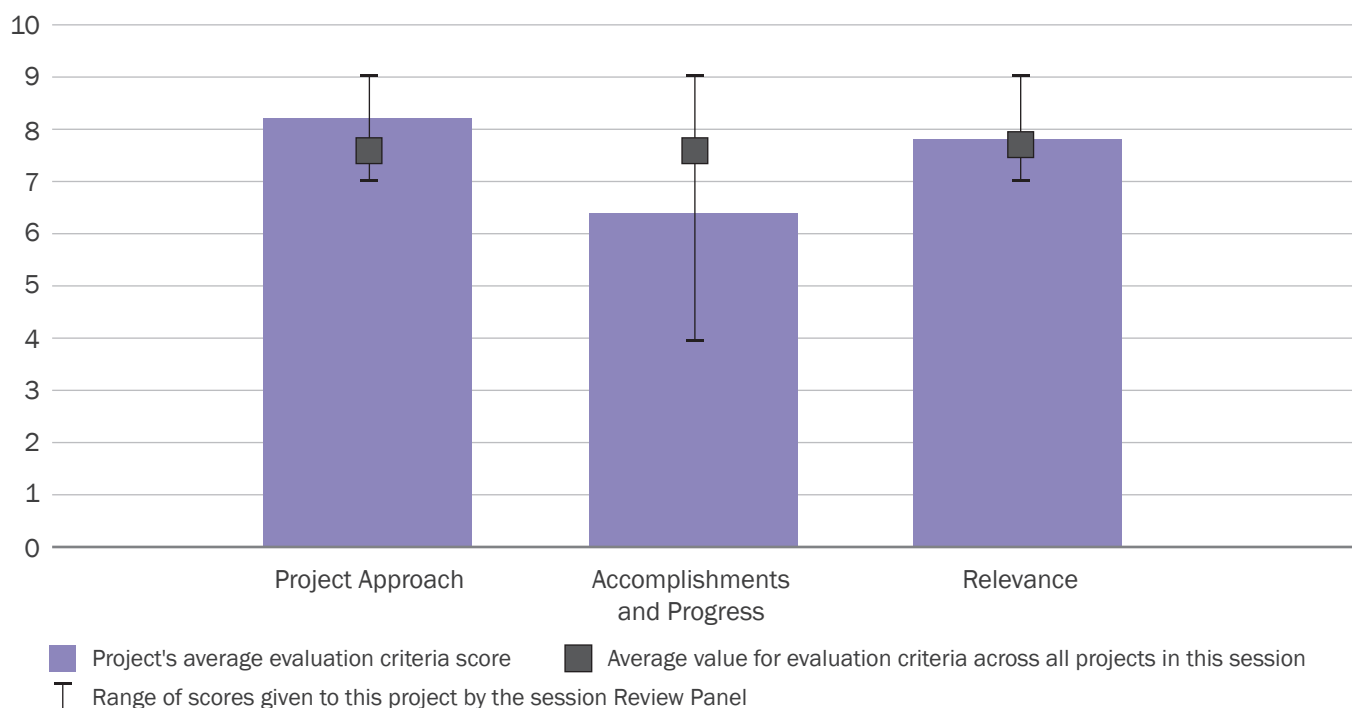

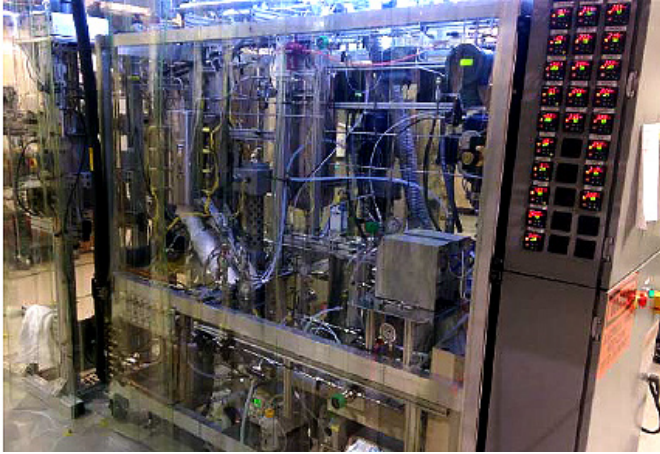

cost info in the slide. Is this proprietary? This was not made clear, so I am asking for clarification on slide 23. My concern is the cost of three solvent systems for separation. I have no concern over Virent backend-to-fuel conversion technology, which was well-demonstrated prior to the project. They were off on some targets for front-end separation product recovery.

- The pilot plant built for this project is a significant resource that could be used to develop other solvent and chemical deconstruction technology. The approach of chemical deconstruction followed by hydrothermal extraction still has some promise, so further testing is needed with longer run times that would allow a better assessment of operability. It would be interesting to see the techno-economic analysis data for this approach in comparison to other solvent extraction and pyrolysis approaches.

- This is a great complete project from biomass to transportation biofuel. There was solid project management with proper scheduling, reporting, and key milestones, as well as critical market and business success factors that were clearly defined. The project has passed the technology readiness steps TRL 2 (applied research) and TRL 3 (proof of concept).
- Overall, despite ending the project early, the results were important because of commercially reasonable conditions and cheap solvent (water). Exploring staged hydrothermal liquefaction at relatively mild thermal conditions and achieving 55% solubilization of feed carbon provided an important data set for assessing biomass deconstruction using water. Most traditional pyrolysis type decompositions occur at 400°C, so this work provides very valuable data for assessing recovery of biomass polymers in more native, unmodified forms. Commercial relevance of these polymers is an entirely different challenge.
- This was a well-executed project despite limited technical success. Some form of biomass pre-fractionation will likely be required to efficiently utilize biomass for energy/fuels.

PI Response to Reviewer Comments

No official response was provided at the time of report publication.

RENEWABLE HYDROGEN PRODUCTION FROM BIOMASS PYROLYSIS AQUEOUS PHASE

(WBS#: 2.5.5.403)

Project Description

Aqueous-phase utilization and hydrogen production are two important barriers in the thermochemical biofuels pathway. This project focusses on utilization of the pyrolysis aqueous phase for hydrogen production via microbial electrolysis cell technology. Biocatalysis and electrocatalysis are used to break down complex and inhibitory organic compounds to produce electrons in the anode and reduce protons in the cathode to generate hydrogen. Critical success factors include development of a diverse microbial consortium to convert carboxylic acids, anhydrosugars, furans, and phenolic compounds at sufficient rates to achieve target hydrogen productivity greater than 15 L-H₂/L-reactor-day. Using switchgrass bio-oil aqueous phase, a rate of 11.7 L/L-re-

Recipient:	Oak Ridge National Laboratory
Principal Investigator:	Abhijeet Borole
Project Dates:	10/1/2013–9/30/2016
Project Category:	Sun-setting
Project Type:	FY 2013–CHASE: DE-FOA-0000812
Total DOE Funding:	\$0

actor-day was achieved. Additionally, we demonstrated a hydrogen production efficiency of 62%. This performance is sufficient to now allow commercial consideration of this technology. Microbial electrolysis cell-associated separations, including oil-water separation and effluent cleanup via membranes, were also demonstrated successfully.

Overall Impressions

- The team is to be commended for outstanding work and program. The scale-up to 1 L is critical, and I wish the team success with that objective. A challenging focus will be optimizing biocatalyst growth

Weighted Project Score: 7.5

WWeighting: Approach–25%; Relevance–25%; Accomplishments and Progress–50%.

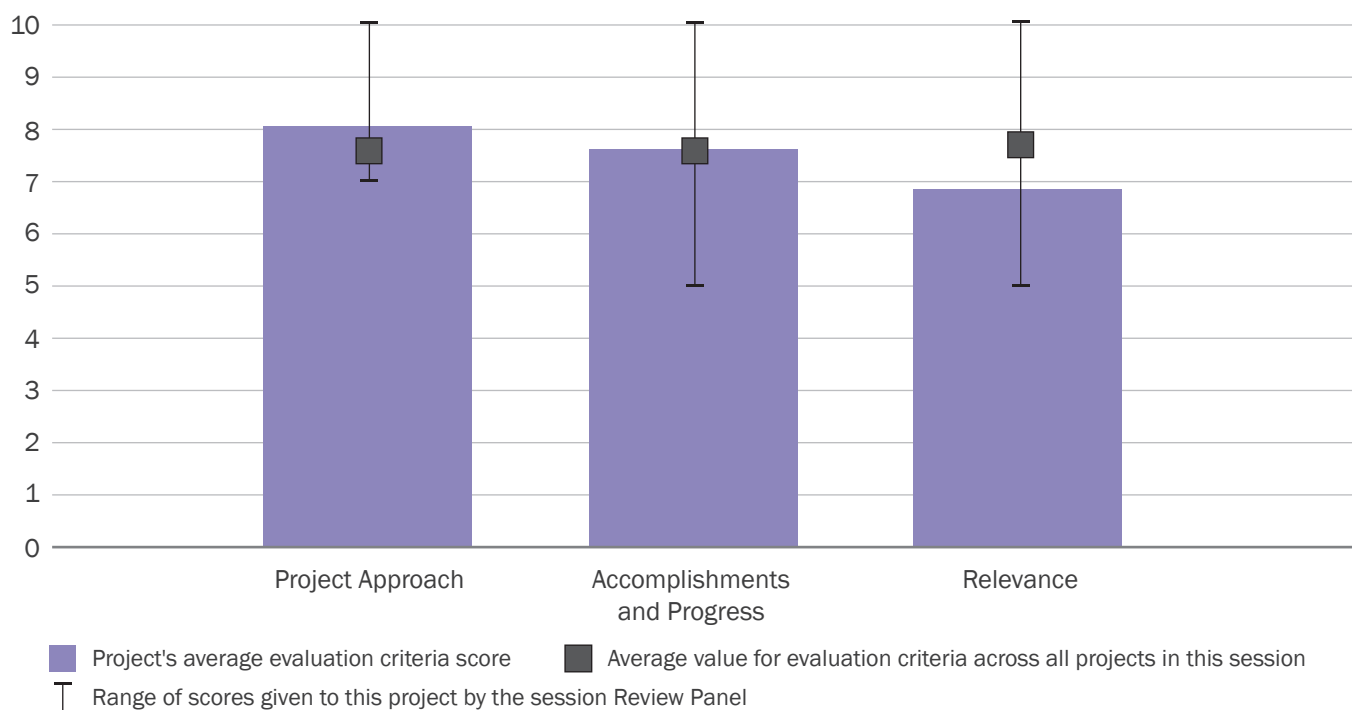



for industrial application. This is always the key issue in all microbial scale-ups, as often this does not translate from laboratory, to pilot, to industrial scale well and has many hiccups, from my own past experience on programs involving biocatalysts (i.e., organisms). Funding for scale-up may require further government funding for reason stated above—that skepticism will be prevalent until proven at a fairly large pilot scale. Thus, the question I have is why is this not being supported beyond 2017 for further scale-up if 1 L is successful?

- The microbial electrolysis cells used in this work are an exciting new development, and BETO should be commended for funding this type of application research.

The cost of the hydrogen produced appears to be tracking higher than the commercial target. This would make the technology viable only in cases where there was very low-cost electricity and a need for hydrogen in stranded locations that it is difficult to reach with normal hydrogen supplies.

The application of this approach may be limited to relatively small-scale operations. When asked about scale-up, the researchers commented that this would

be accomplished by using multiple small modules in parallel and series. This is a very expensive approach.

- This is a good project that has progressed well towards commercialization. There is still a need for additional scale-up and performance optimization and testing.
- Overall, this is a welcome addition to the growing portfolio of bio-hydrogen production technologies. Speciation of electroactive anaerobic microbial community generated interesting data that should contribute positively to the growing microbial fuel cell community. However, it is unclear how this technology would transfer to the existing fixed-film or membrane bioreactor industry. The most parallels would be drawn with the commercialized reactors in use at wastewater treatment plants, so some level of comparison should be completed to improve commercial relevance. Additionally, clearly establishing the preferred carbon source of these organisms is important for future work.
- I'm open to the idea of using the bio-derived aqueous phase for hydrogen generation, but it seems that carbon recovery is likely to be more economically sound.

PI Response to Reviewer Comments

- Thank you so much for the positive comments. We greatly appreciate the question raised by the reviewer: “Thus, the question I have is why is this not being supported beyond 2017 for further scale-up if 1 L is successful?”

Scale-up of the microbial electrolysis cell technology is the next step. However, since this is a sun-setting project, we have no means of pursuing it at this time. We hope BETO will fund further work to scale this technology.

BUILDING BLOCKS FROM BIOCRUDE: HIGH VALUE METHOXYPHENOLS

(WBS#: 2.5.5.406)

Project Description

Integrating biofuels production with bioproducts presents an opportunity to explore options for recovering high-value chemicals as additional revenue-generating products from biofuel conversion pathways. Also, the inherent functionalized nature of biomass offers a unique opportunity for producing oxygenated chemicals that are not easily synthesized from petroleum. However, efficient separation approaches are required to recover the oxygenated species as marketable value-added products. RTI International, Arkema, and AECOM are investigating the technical feasibility and economic potential, as well as the environmental and sustainability benefit, of recovering mixed methoxyphenols (eugenols and guaiacols) from biocrude as building block chemi-

Recipient:	RTI International
Principal Investigator:	Ofei Mante
Project Dates:	10/1/2016–9/30/2019
Project Category:	New
Project Type:	FY 2016–MEGA-BIO
Total DOE Funding:	\$1,987,148

icals alongside the production of biofuels. The optimization of a comprehensive separation strategy to recover the target methoxyphenols as bioproducts is at the heart of this project. Successful completion of this research will result in a process design, techno-economic analysis (TEA), and life-cycle analysis of an integrated biorefinery for biofuel production and co-product recovery. A product development assessment will also be conducted. Achieving technical success in recovering high-value methoxyphenols from biocrude prior to upgrading to biofuels could provide a significant source of revenue to improve overall process economics and help meet the \$3/gge modeled production cost target for advanced biofuels technologies by 2022.

Weighted Project Score: 5.7

WWeighting: Approach–25%; Relevance–25%; Accomplishments and Progress–50%.

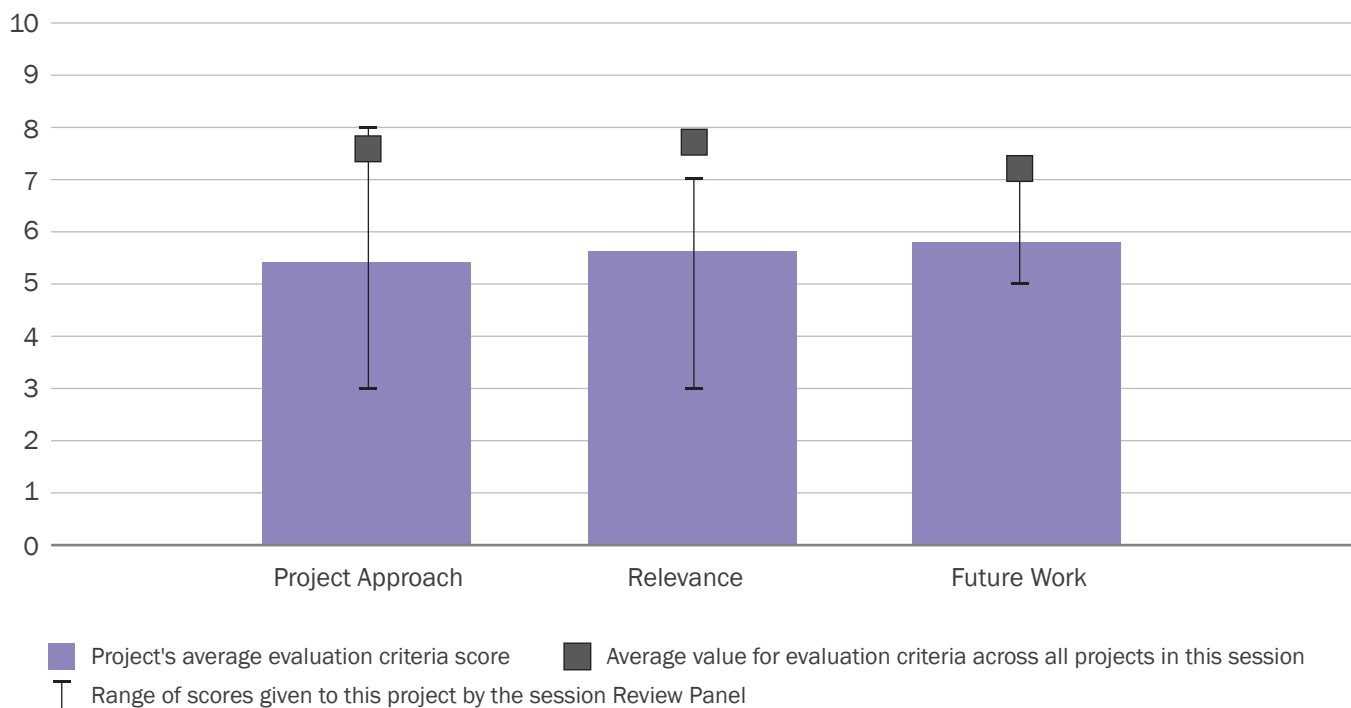



Overall Impressions

- This is one of the few projects where I feel that the targets are not relevant to the goals of BETO. The current market for eugenol is in the few-thousand-ton range. Its high cost is reasonable since eugenol end-use is very specialized, the product is very sensitive to minor odor components, and end-users often require further purification.

Billion-ton feed use is mismatched with thousand-ton market and, as such, cannot impact BETO fuel cost in the long term. I applaud the team's results, which were outstanding, but relevance outweighs the solid work results of the program. I am not sure that the TEA would provide any different result if market impact is taken into account. Any substantial volume production of the material targets would totally disrupt the current market price. Again, the team did a nice job working the program and accomplishments on goals, but the program is not a fit with BETO needs.

- Producing higher-value chemicals to support the development and use of renewable fuels has become a major theme in the BETO development efforts. The hope is that these could supplement or replace renewable energy credits. Until now, the justifications

for this program for bio-oils have not been based on a rigorous TEA with participation of a chemical manufacturer. This project addresses this need. The program leverages RTI's ability to produce large quantities of cata-pyrolysis and pyrolysis liquids. This is a key enabler of many related projects involving upgrading of the liquids and aqueous-vapor products and should be funded if possible.

The difficulty with this project is that the proposed experimental work is weak. There is no evidence of a deep understanding of the problems associated with separation of bio-oil relative to other types of chemical feedstocks. Information from prior efforts to separate bio-oil in the open literature and patents are not included in the planning and used as a kick-off. There are processes for separating chemicals from coal gasification, coal tar, and low-temperature coal pyrolysis in the past that include commercial process design and economics.

- This is an interesting project that may add value to integrated biorefinery projects. It will be interesting to follow the progress of this newly started project.
- Overall, the methoxyphenol objective is sound (at small scales), and the equipment is proven and makes sense. However, the project must seriously consider efficiencies for the results to have any commercial relevance. If the target is methoxyphenols and the feedstock is biomass, moving to a lignin-only, solvent liquefaction pyrolysis is both logical and necessary.
- I am highly skeptical that there is any market for a mixed biogenic phenol streams. Therefore, in budget period two, identification of feasible purification strategy and identification of markets will need to be efficiently executed for this project to be successful.

PI Response to Reviewer Comments

- This is a new R&D project that was awarded under the MEGA-BIO: Bioproducts to Enable Biofuels

FOA (DE-FOA-0001433). The objective of the FOA was to examine strategies that capitalize on revenue from bioproducts as part of cost-competitive biofuel production. The pathways that were considered responsive to the FOA included a route to a platform chemical that could be converted to products/fuels or a route that co-produces chemicals and fuels. Based on the FOA, this project proposed to develop and optimize a hybrid separation strategy to recover high-value methoxyphenols as bioproducts to improve the process economics and environmental impact of the production of advanced biofuels via catalytic pyrolysis integrated with hydroprocessing.

Furthermore, this project falls under the FOA's topical area 1 (TRL 2–3), which seeks to optimize one-unit operation of a proposed pathway. Hence, the technical focus of this project is not on the production of methoxyphenols, but rather on the separation of methoxyphenols present in biocrude produced from the biomass catalytic pyrolysis technology. While the targeted methoxyphenols could be produced from isolated lignin stream, this doesn't fit into the scope of the present project as 51% of the biomass carbon is required to end up in an advanced biofuel. The role of Arkema in evaluating the market potential of the mixed methoxyphenols and developing a business opportunity for the use of the methoxyphenols as chemical building blocks for other high-value products cannot be overstated. Additionally, the participation of AECOM in evaluating the impact of separating out the methoxyphenols as bioproducts on the process economics and life cycle of the pathway is a critical aspect of the project.

Preliminary TEA suggests that the recovery of methoxyphenols could help reduce the cost of fuel production if economical and efficient separation of methoxyphenols could be achieved. Based on available data, the market prices of methoxyphenols are between \$3–\$5/kg. Effective and efficient sepa-

ration of methoxyphenols has the potential to reduce the overall biofuel cost of production. Bioproducts recovery has the potential to have a much more significant impact on the process economics compared to, for example, the application of D5 Renewable Identification Numbers at \$1.00/gal (\$0.33/kg) for advanced biofuels.

The project is divided into eight tasks over 36 months, with two go/no-go decision points and three validations (initial, intermediate, and final). The experimental work includes bench-scale development of a separation strategy to recover methoxyphenols with 85% efficiency, 10% residual losses, and methoxyphenol purity of at least 90%. There is also a task on the scale-up of the separation method once developed to perform laboratory separation evaluation. Other experimental tasks include upgrading of the remaining biocrude after separation and evaluation of co-product pathway that utilizes the mixed methoxyphenols as a chemical feedstock. The market feasibility assessment, product development, TEA, and life-cycle analysis are other tasks to be performed in the project.

The separation work will focus on solvent extraction using alkaline and switchable hydrophilic solvents (e.g., N,N-dimethylcyclohexylamine) and fraction distillation under vacuum in the development of a hybrid approach for isolation, concentration, and purification on the methoxyphenols bioproduct. The research plan and the project execution strategy have been designed to be flexible enough to accommodate possible technical challenges. For instance, adsorption separation (e.g., using an acrylic ester sorbent XAD-7 or a strongly basic anion exchange resin) is in the separation research plan as a mitigation strategy to ensure that the target concentration of methoxyphenols is achieved. The challenge with final product quality/purity will be addressed in the project work, and the cost of additional separation processes will be captured in the TEA.

MELT-STABLE ENGINEERED LIGNIN THERMOPLASTIC: A PRINTABLE RESIN

(WBS#: 2.5.6.103)

Project Description

The objective of this research is to produce and commercialize lignin-derived, industrial-grade polymers and composites with properties, including printability, rivaling current petroleum-derived alternatives. Technologies that enable high-value uses of lignin, a biorefinery waste stream, are important to facilitate the cost-competitive production of biofuels. In this research, we will produce a novel family of commercial-ready, lignin-based thermoplastic polymers and polymer composites suitable for high-volume applications, specifically those that are inherently recyclable, with the capability to retain their unprecedented mechanical properties after repeated thermal processing. We utilized fractionated lignins to melt-mix with soft rubbery matrices. Various mixtures

Recipient:	Oak Ridge National Laboratory
Principal Investigator:	Amit Naskar
Project Dates:	4/1/2016–9/30/2018
Project Category:	Ongoing
Project Type:	Annual Operating Plan
DOE Funding FY 2014:	\$0
DOE Funding FY 2015:	\$0
DOE Funding FY 2016:	\$500,000
DOE Funding FY 2017:	\$500,000

were investigated for making 3D-printing filaments. Interestingly, strong interactions between source-specific lignin macromolecules and cross-linking chemistry present an excellent and unexpected thermal response on elastic recovery of the material. Therefore, tuning such properties of selected composites was investigated. A new composition based on thermoplastic matrix reveals better control with rheological behavior. These compositions offer potential intellectual properties, and currently three industrial partners are negotiating license options (on background intellectual properties) with

Weighted Project Score: 7.6

Weighting: For ongoing projects, there is equal weighting across all four evaluation criteria: Approach, Relevance, Accomplishments and Progress, and Future Work.

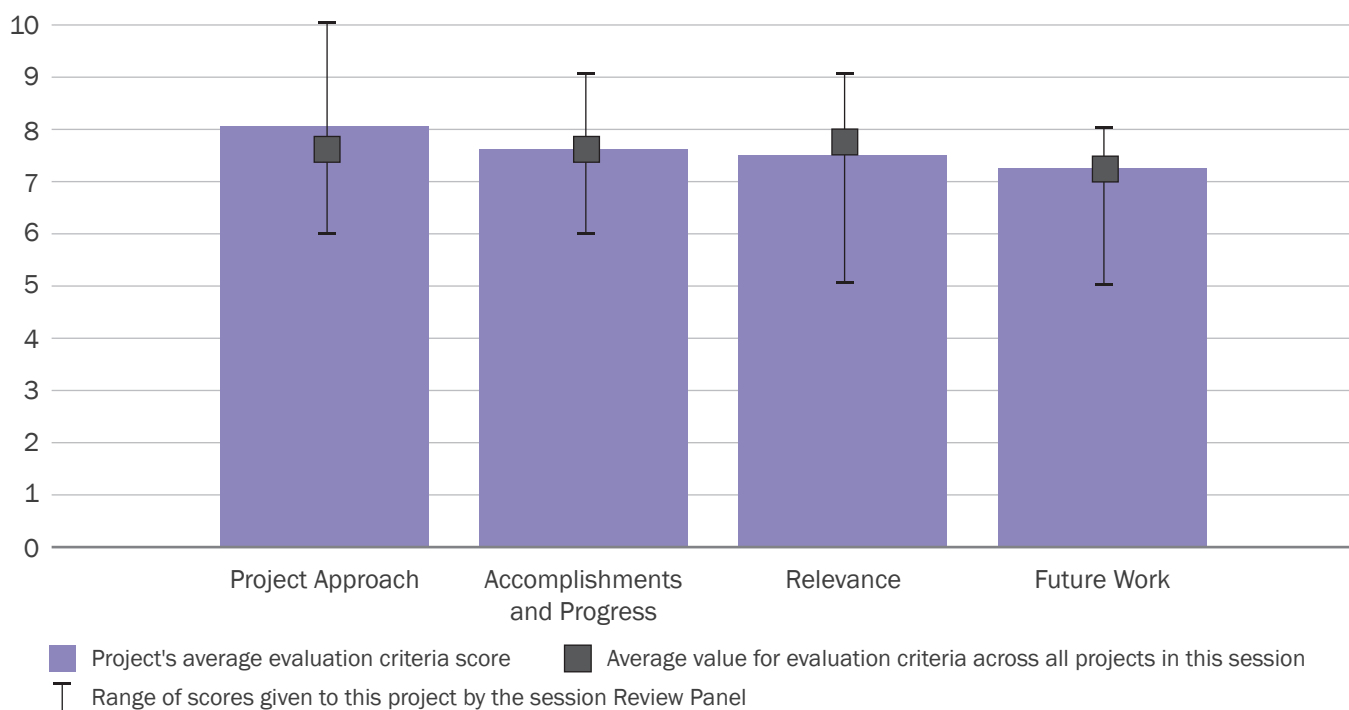

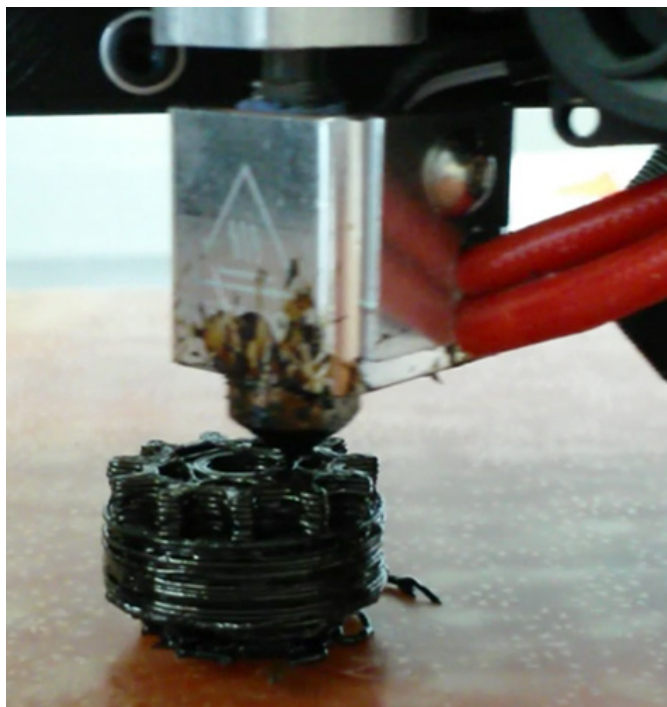

Oak Ridge National Laboratory. Our approach utilizes unmodified lignin at 50% volume to produce engineered plastic materials with values of \$2,000–\$5,000/metric ton.

Overall Impressions

- Overall assessment: This is an extremely relevant approach to fixing the old problem of how to make money on lignin. This could be solution to many of the economic challenges of the more complex conversion of sugar and other intermediates to fuels, if successful, and it is a nice way to increase the use of carbon in biomass in a high-value-added way.

Adoption in this industry can be challenging for new materials processed, as noted by lengthy time it took new plastics like polylactic acid, etc., to gain interest and even still, there was slow market penetration. Early involvement of the plastic industry is critical.

- The project is great example of finding value-added use for the co-products from biomass deconstruction. Using lignin directly to produce a polymer product has great potential. The researchers have

generated significant commercial interest. BETO should continue to fund efforts to find these types of alternative uses for the co-products from biomass conversion.

No information on the potential market size was presented; as a result, the impact of this work on overall fuel production cannot be evaluated.

- This is a successful project that may result in valuable licensing opportunities.
- Overall, this is an extremely interesting project with a great deal of potential. The team is correct that enabling the use of lignin as a component in 3D-printable resins could help open a significant and important regional biopolymer market. Exploration of stress versus strain for different lignin–nitrile butadiene rubber mixtures was very compelling. Rheology data is a nice complement and supports a high degree of integration between the polymers, but proof of cross-linking needs additional work.
- This is an interesting extension of Oak Ridge National Laboratory's base technology in 3D printing. Lignin valorization will be a key enabling factor for the economical utilization of fractionated biomass. I look forward to more detailed market analysis to demonstrate that this has the potential to be more than a niche product.

PI Response to Reviewer Comments

- So far, we have developed a composition that outperforms some petroleum-derived plastics (e.g., ABS resin). Appropriate market size will be estimated based on ease of scaled-up processing and the aging performance of these new compositions.

Penetrating the market with these new compositions is indeed challenging. Early involvement within the plastic industry is very important! Fortunately, our background intellectual property includes primarily toughened lignin polymer blends (pending patent

application 14/798,729) and is being commercialized by UT-Battelle, LLC (Oak Ridge National Laboratory). Three license applications are being considered. We admit that these compositions are thermoplastic elastomers and have not yet demonstrated 3D printability. However, in the last quarter (January–March 2017), based on new results, we have disclosed two new intellectual properties related to 3D printability of lignin-based thermoplastics. In these cases, as-received lignin aids 3D printability as it offers room-temperature rigidity and high-temperature plasticity. We expect combination of our ongoing commercialization effort and the development of newer printable compositions will strengthen our goal. Also, we know that one of the licensees wants to incorporate part of this technology into the construction industry. This could be a low-hanging fruit.

We are currently working on demonstrating the nitrile butadiene rubber–lignin interaction by nuclear magnetic resonance, rheology, swelling data, and solvent based separation and quantification of unbound lignin to the nitrile butadiene rubber matrix.

Appropriate market size analysis will be conducted based on ease of scaled-up processing and the aging performance of these new compositions. At this moment, our priority is to establish fundamental understanding associated with the compositions and to fine-tune performance and processability of the material. Once the TRL is elevated (for 3D printable materials), we will put our best effort forward to deliver a successful commercialization and a product.

CHEMCATBIO OVERVIEW

(WBS#: CCB1)

Project Description

As part of the DOE Energy Materials Network, ChemCatBio leverages unique DOE national laboratory capabilities to address technical risks associated with accelerating the development of catalysts and related technologies for the commercialization of biomass-derived fuels and chemicals, leading to enhanced energy security and national leadership in the global bioeconomy. ChemCatBio consists of technical capabilities experts, technology transfer agreement experts, and data experts from seven DOE national laboratories with demonstrated experience in developing advanced catalytic materials. A steering committee—made up of technical capability experts from the participating laboratories and DOE representatives—guides the ChemCatBio consortium's research direction and approach, coordinated streamlined industry access, and identification and incorporation of unique national laboratory capabilities.

Recipient:	National Renewable Energy Laboratory, Pacific Northwest National Laboratory
Principal Investigator:	Josh Schaidle
Project Dates:	10/1/2016–9/30/2019
Project Category:	Ongoing
Project Type:	Annual Operating Plan
DOE Funding FY 2014:	\$0
DOE Funding FY 2015:	\$0
DOE Funding FY 2016:	\$0
DOE Funding FY 2017:	\$0

This consortium establishes an integrated and collaborative portfolio of catalytic and enabling technologies that spans from foundational science to demonstration-scale integrated biomass-to-fuels processes. The outcome is a reduction in the time and cost required to transition catalytic materials from discovery to deployment by targeting both pathway-specific and overarching catalysis challenges and by engaging industry at all phases of the materials development process.

Weighted Project Score: 7.5

Weighting: For ongoing projects, there is equal weighting across all four evaluation criteria: Approach, Relevance, Accomplishments and Progress, and Future Work.

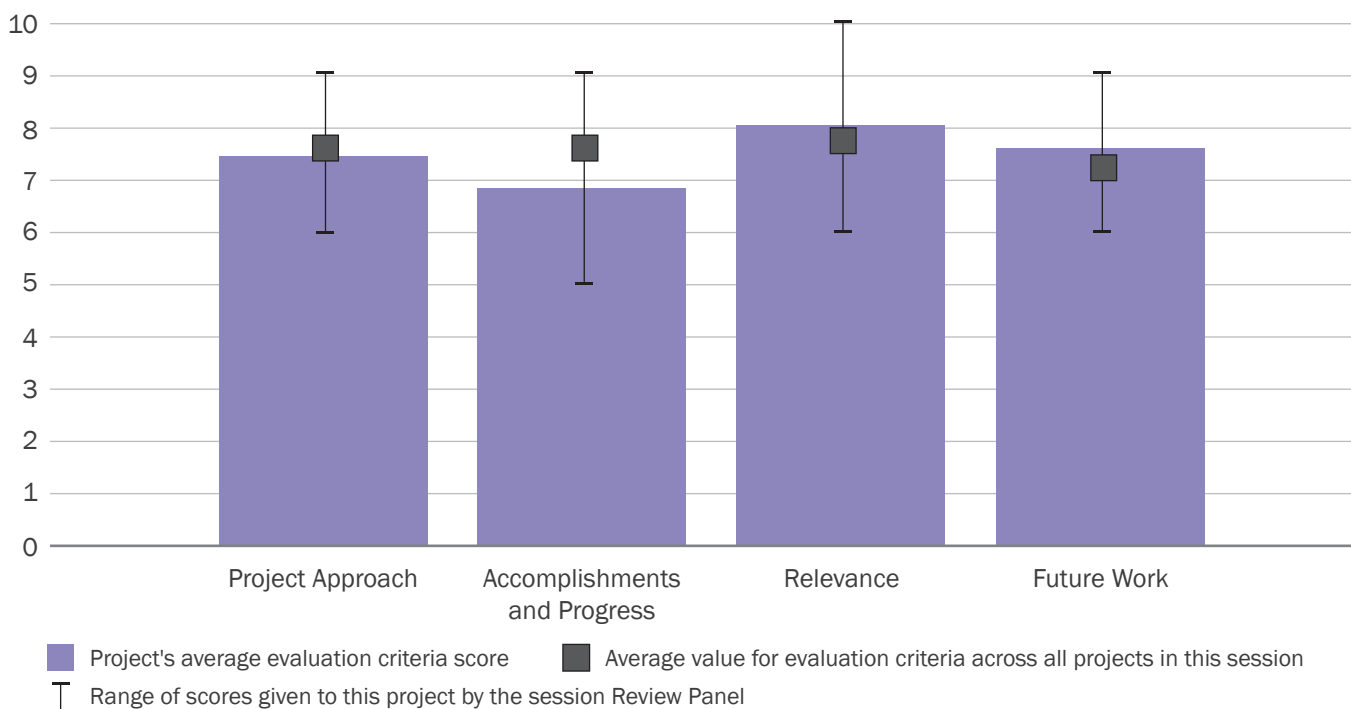

Overall Impressions

- This is a great team and an important structure to have in place to make sure catalyst development does not slow progress of the projects. An industry advisory board is critical for such a group and needs to be set up ASAP. I would make sure you get a variety of people, not just from catalyst companies, but also technical catalyst R&D people from industry—both chemical and fuels that use catalyst suppliers and have developed with suppliers' new catalysts. Also, perhaps an industry advisory board would be well-suited for evaluating the project team's spent catalyst for front-end trapping.

Also, as I have indicated, it would be good to make sure that sufficient industrial catalyst screening has taken place as well. I did not feel I had seen this in the reviews I sat through. Was this done prior? There are, as I have indicated, good sources of actual catalyst available without license or restrictions. These come from companies (I used Resale Catalyst, which has a good stock usually). They are reasonable on cost of sampling, at least in 2011–2013 or so when I used them to explore conversion chemistry on stream. Pints or quarts were available for a few hundred dollars at the time, each with a discount for a larger number of sampled catalysts.

- The idea behind the consortium should eventually lead to more rapid improvement. The project managers should be looking for examples of synergy that would have not occurred in the absence of the consortium. The consortium should be evaluating ideas from outside the laboratories in the patent and open literature.
- This is an important project that will be even better by involving industrial partners in the guidance of future work. The risk of reinventing “the wheel” will be greatly reduced, and more realistic (lower) catalyst costs may be achieved.

- Overall, this is a great consortium that has the potential to drive alignment across a wide array of projects and programs. However, BETO exists more to enable the biofuels/bioenergy industry, as opposed to deploying and commercializing home-grown new technologies. As such, integrating all phases of catalyst R&D, discovery through deployment, could put ChemCatBio in a redundant position, with industrial catalyst partners doing exactly the same thing (but with more money and resources). As ChemCatBio is unlikely to produce commercially adopted catalysts, its focus on reducing the catalyst development life cycle should be based on enabling industry catalyst partners to commercially produce catalysts that, in turn, enable the biofuels/bioenergy industry. This enabling function must be rooted in recommendations from the catalyst industry itself.
- This is an ambitious project. I am skeptical that catalyst development cycle time (time from discovery to commercialization) will be significantly impacted, mainly due to reluctance of industry to be completely forthcoming about what it knows and what it wants. However, if the underlying projects significantly build the catalyst fundamentals expertise at the laboratories, that will be a valuable contribution to the catalysis community.

PI Response to Reviewer Comments

- We greatly appreciate the reviewers' constructive feedback. We agree that the consortium has great potential to accelerate catalyst development and lead to greater technology advancements. The reviewers have adeptly identified many of the key success factors to the consortium, including industry engagement, a clear value proposition that does not compete with existing entities in the catalyst development ecosystem, a focus on fundamentals that enable deployment, and the fostering of synergies between core projects and enabling projects.

We will use this excellent feedback to guide our path forward.

We agree with the reviewers that forming the industry advisory board and engaging industry are keys to the success of the consortium. We are actively working on forming the industry advisory board and have scheduled our first stakeholder listening day for June 9, to be held in conjunction with the North American Catalysis Society meeting in Denver, Colorado. We just finished drafting an industry advisory board charter and have a list of potential members that we will be reaching out to within the next couple of months. These potential members have diverse backgrounds and experience and can provide technical guidance, insights into industrial relevance, “big picture” perspectives, and policy implications. We plan to use our first stakeholder listening day in June to shape our value proposition for the consortium and to ensure that we are not directly competing with industry. We appreciate the guidance to focus on the fundamentals (i.e., characterization, mechanisms, modeling) and leave the commercial catalyst formulation to industry. We apologize if our use of the word “deployment” was misleading. We should have chosen a different phrase. We do not intend to take catalysts to market or try to produce finished formulations. We meant that one capability of our consortium is catalyst evaluation at the pilot scale using our in-house systems, which saves money and reduces risk for industrial partners, thus enabling commercial deployment.

Even though this consortium is still in its infancy, we have already identified specific synergies, including (1) development of hydrothermally-stable mixed metal oxide ketonization catalysts that are applicable to multiple conversion pathways, as well as (2) identification of linkages between vapor-phase and liquid-phase upgrading over metal carbide catalysts, allowing for the development of deactivation mitigation strategies and approaches for enhancing performance through promoters/dopants. As the consortium matures, we expect that these synergies will grow. Experience from the Consortium for Computational Physics and Chemistry suggests it takes over 3 years before such a complex team is fully integrated and synergies are being turned into success stories. We are leveraging their experience to hopefully reach that point sooner for ChemCatBio. We expect to demonstrate significant successes in the coming years that would not have been possible without the consortium structure and agree with the reviewers that this is a key success factor of the consortium.

We thank the reviewers for their suggestion to evaluate ideas from outside the laboratories in the patent and open literature and reach out specifically to those groups. We also appreciate the suggestion to evaluate more industry standard catalyst materials to compare to catalysts under development within the consortium. We will pursue both of these approaches moving forward.

BIOMASS GASIFICATION FOR CHEMICALS PRODUCTION USING CHEMICAL LOOPING TECHNIQUES

(WBS#: EE0007530)

Project Description

The biomass-to-syngas process is a unique gasification process developed at Ohio State University that provides a highly cost-effective and energy-efficient alternative to the conventional biomass gasification processes. The gasification of biomass is accomplished through the unique combination of a co-current moving bed reactor and iron-titanium composite metal oxide oxygen carrier developed at Ohio State. It allows for conversion of biomass to high-quality syngas with an H₂:CO ratio of 2:1 in a single step without the use of molecular oxygen and capital-intensive units like a tar reformer, water gas shift reactor, and air separation unit. Such high-quality syngas generated permits the downstream processing to be readily conducted to produce chemicals and liquid

Recipient:	Ohio State University
Principal Investigator:	Andrew Tong
Project Dates:	10/1/2016–9/30/2019
Project Category:	New
Project Type:	FY 2015–BRDI
Total DOE Funding:	\$1,500,000
DOE Funding FY 2015:	\$0
DOE Funding FY 2016:	\$0
DOE Funding FY 2017:	\$0

fuels without requiring syngas conditioning systems for tar cracking and/or hydrogen upgrading. The 1 Kath bench-scale moving bed reactor studies have confirmed that biomass gasification with varied rates of low-steam feeding can achieve the H₂:CO ratio in syngas of 1.7 to 2.2 with greater than 60% syngas purity. The project's specific goals are to (1) design, construct and operate a 10 Kath commercially scalable sub-pilot biomass-to-syngas system, and (2) complete a comprehensive techno-economic analysis of the biomass-to-syngas process using methanol production as an example. The support from 10 industrial partners will ensure the com-

Weighted Project Score: 7.6

Weighting: Approach–25%; Relevance–25%; Future Work–50%.

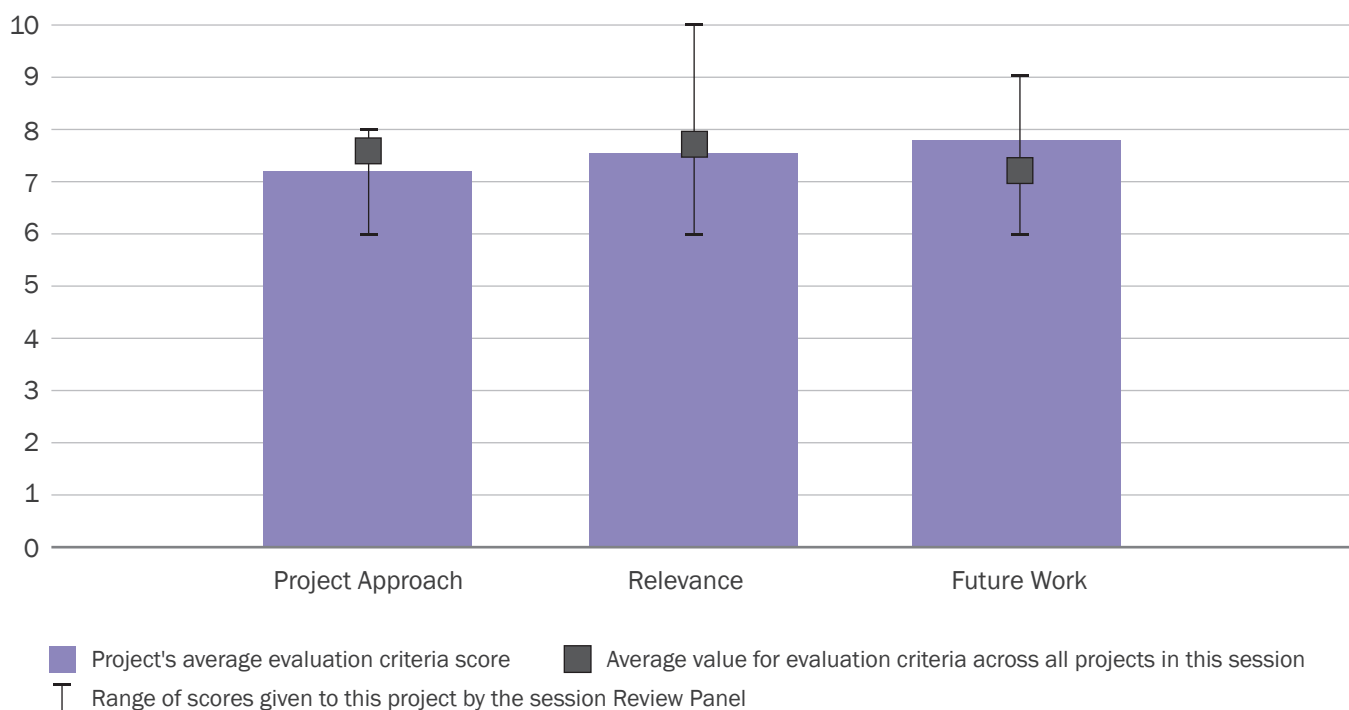

mercial relevance of the proposed sub-pilot testing and techno-economic analysis objective.

Overall Impressions

- I really think this project has a lot of potential to help BETO meet their goals. The key will be cost/size analysis and long-term operation without issues at larger scale. Close attention to feed input and completeness of conversion in larger unit operation will be critical. One concern is how fast and at what cost feed can be inputted into system. High cost and slow speed can be avoided by addressing the issue of irregular particle sizes causing plugging, considering that they are running solid catalyst through the system along with woody biomass particles or later grasses. I did not see any info about how ash will be handled in the system and its impact on the catalyst. I see that mercury is accounted for in the system, and acid gas removal as well, but not addressing ash? Is it a given that it will be removed post-combustor, or will the unit have to be shut down, cleaned of ash, and restarted again?
- Chemical looping is an intriguing concept for controlling the reaction of oxygen and preserving biomass carbon. This project provides the best opportunity to test this concept for biomass under potential commercial conditions. There is a large potential payoff in terms of improved yields and cost reductions.

The project leverages a large investment in evaluating the chemical looping approach. There is a unique large test facility that can be adapted to

evaluating biomass by building an add-on modular pilot unit.

- This will be interesting to follow. It is too early to evaluate if the cost savings due to process intensification will be real or if they will be counteracted by the new biomass-to-syngas technology itself.
- Overall, this is an interesting project that could bring some much-needed innovation into the gasification space. Chemical looping oxidants has a colorful history with coal and petrochemical conversions, but doesn't have much of a history with biomass. Looping of bed material through a combustor does, however, have a considerable history with biomass (and should be studied to inform design decisions here). As long as contaminants, ash, operating conditions, and bed material chemistry are watched closely, this work has the potential to generate some compelling results. Economically, carbon conversion efficiency will also be an important variable since biomass heating is generally more expensive than natural gas heating.
- Chemical looping reactor technology always seems like such a good idea for oxidation reactions, but there are well-documented case studies showing the operational challenges. This organization has the skills to perform the technical tasks, but they should be fully aware of the likely problems. Good luck.

PI Response to Reviewer Comments

No official response was provided at the time of report publication.

2000 μm

BIOCHEMICAL CONVERSION R&D



TECHNOLOGY AREA



CONTENTS

INTRODUCTION	331
BIOCHEMICAL CONVERSION R&D OVERVIEW	331
BIOCHEMICAL CONVERSION R&D REVIEW PANEL	332
TECHNOLOGY AREA SCORE RESULTS.....	333
BIOCHEMICAL CONVERSION R&D REVIEW PANEL SUMMARY REPORT	334
BIOCHEMICAL CONVERSION R&D PROGRAMMATIC RESPONSE	340
PRODUCTION OF HIGH-OIL, TRANSGENE FREE CAMELINA SATIVA PLANTS	342
BIOCHEMICAL PLATFORM ANALYSIS PROJECT	346
DEVELOPING THERMOASCUS AURANTIACUS AS A THERMOPHILIC FUNGAL PLATFORM FOR INDUSTRIAL PRODUCTION OF CELLULASES.....	350
LIGNOCELLULOSE CONVERSION TO HYDROCARBON FUELS - DECONSTRUCTION	353
BIOMASS CONVERSION TO ACRYLONITRILE MONOMER-PRECURSOR FOR PRODUCTION OF CARBON FIBERS	356
UPGRADING LIGNIN-CONTAINING BIOREFINERY RESIDUES FOR BIOPLASTICS.....	358
BIOLOGICAL LIGNIN DEPOLYMERIZATION	363
FUNGAL GENOMICS— GENETICS (FORMERLY: FUNGAL GENOMICS).....	366
SYNTHETIC METABOLIC PATHWAYS FOR BIOCONVERSION OF LIGNIN DERIVATIVES TO BIOFUELS.....	369
BIOLOGICAL UPGRADING OF SUGARS	372
CONTINUOUS MEMBRANE-ASSISTED IBE FERMENTATION FROM AVAP CELLULOSIC SUGARS	375
ENGINEERING CLOSTRIDIA FOR N-BUTANOL PRODUCTION FROM LIGNOCELLULOSIC BIOMASS AND CO ₂	378
SECOND-GENERATION MIXOTROPHY FOR HIGHEST YIELD AND LEAST-EXPENSIVE BIOCHEMICAL PRODUCTION	381
FERMENTATION PRODUCTION OF TRICARBOXYLIC ACID CYCLE (TCA)–DERIVED CHEMICALS USING CELLULOSIC SUGARS.....	384
INTEGRATED PROCESS FOR COMMERCIAL PRODUCTION OF FARNESENE FROM DOMESTIC LIGNOCELLULOSIC FEEDSTOCK.....	387
BIOLOGICAL CONVERSION OF THERMOCHEMICAL AQUEOUS STREAMS	390
LIGNIN UTILIZATION	393
RENEWABLE CARBON FIBER CONSORTIUM	396
ENGINEERING THERMOPHILES TO PRODUCE DROP-IN FUELS FROM SYNGAS.....	399
DEVELOPMENT OF A SUSTAINABLE GREEN CHEMISTRY PLATFORM FOR PRODUCTION OF ACETONE AND DOWNSTREAM DROP-IN FUEL AND COMMODITY PRODUCTS DIRECTLY FROM BIOMASS SYNGAS VIA A NOVEL ENERGY-CONSERVING ROUTE IN ENGINEERED ACETOGENIC BACTERIA.....	402
BIO-SYNGAS TO FATTY ALCOHOLS AS A PATHWAY TO FUELS	405
BENCH SCALE INTEGRATION.....	407

SEPARATIONS DEVELOPMENT AND APPLICATION	410
BIOCHEMICAL PROCESS PILOT-SCALE INTEGRATION.....	413
TARGETED MICROBIAL DEVELOPMENT	416
PROCESS INTENSIFICATION FOR THE REDUCED COMMERCIAL CAPITAL EXPENDITURE OF BIOFUELS PRODUCTION USING DYNAMIC METABOLIC CONTROL	419
BIOCHEMICAL PROCESS MODELING AND SIMULATION.....	421
ANALYTICAL METHODS DEVELOPMENT AND SUPPORT.....	424
ADVANCED SUPERVISORY CONTROL AND DATA ACQUISITION (SCADA) FOR BIOCHEMICAL PROCESS INTEGRATION (WITH BEND).....	427
AGILE BIOMANUFACTURING FOUNDRY	431
MAXIMIZING MULTI-ENZYME SYNERGY IN BIOMASS DEGRADATION IN YEAST.....	435
SYNTEC—SYNTHETIC BIOLOGY FOR TAILORED ENZYME COCKTAILS	438
DESIGN AND OPTIMIZATION OF BIOCHEMICAL / BIOFUEL PRODUCTION WITH BIOSENSOR-GUIDED SYNTHETIC EVOLUTION.....	440
SYNTHETIC MICROORGANISMS TO ENABLE LIGNIN-TO-FUEL CONVERSION	443
ENZYME ENGINEERING AND OPTIMIZATION (TARGETED CONVERSION RESEARCH - RATIONAL DESIGN).....	446
LOW-ENERGY MAGNETIC FIELD SEPARATION USING MAGNETIC NANOPARTICLE SOLID ADSORBENTS.....	449
SEPARATIONS CONSORTIUM	452
ADVANCED BIOFUELS PROCESS DEMONSTRATION UNIT (ABPDU)	455
IMPROVING TOLERANCE OF YEAST TO LIGNOCELLULOSE-DERIVED FEEDSTOCKS AND PRODUCTS	459

INTRODUCTION

In the Biochemical Conversion Research and Development (R&D) session, five external experts from industry and academia reviewed a total of 39 presentations (representing more than 39 projects, as a few presentations were collaborations of different projects across multiple national laboratories).

This review addressed a total U.S. Department of Energy (DOE) investment value of approximately \$140,331,161, representing approximately 19% of the Bioenergy Technologies Office (BETO or the Office) portfolio reviewed during the 2017 Project Peer Review. During the Project Peer Review meeting, the principal investigator (PI) for each project was given 20–60 minutes (depending on the project’s funding level and relative importance to achieving BETO goals) to deliver

a presentation and respond to questions from the Review Panel.

The Review Panel evaluated and scored projects for their project approach, technical progress and accomplishments, relevance to BETO goals, and future plans. This section of the report contains the results of the project review, including full scoring information for each project, summary comments from each reviewer, and any public response provided by the PI. Overview information on the Biochemical Conversion R&D Program, full scoring results and analysis, the Review Panel’s summary report, and BETO’s programmatic response are also included in this section.

BETO designated Jay Fitzgerald as the Biochemical Conversion R&D Technology Area Review Lead. In this capacity, Dr. Fitzgerald was responsible for all aspects of review planning and implementation.

BIOCHEMICAL CONVERSION R&D OVERVIEW

The Biochemical Conversion R&D Technology Area focuses on R&D of biological processes that convert biomass to biofuels, chemicals, and power. Biochemical processes also complement thermochemical conversion by providing residual materials for further processing.

Projects presented in the Biochemical Conversion session include a broad range of efforts, generally targeted for one or more of three purposes: (1) to deconstruct lignocellulose into biochemical intermediates, such as cellulosic sugars (both five-carbon (C5) and six-carbon (C6)) and lignin; (2) to biologically upgrade those biochemical intermediates into fungible liquid trans-

portation fuels and bioproducts; and (3) to biologically upgrade thermochemical intermediates (gaseous or aqueous). Prior to fiscal year (FY) 2012, BETO focused on converting cellulose to ethanol and utilizing lignin for power. In 2012, based on integrated pilot-scale runs, BETO estimated a minimum cellulosic ethanol selling price at an nth plant of \$2.15/gallon (in 2007 dollars, with a \$58.50/ton feedstock cost and a conversion contribution cost of \$1.32/gallon).²⁹

After reaching this cost target, BETO shifted research from cellulosic ethanol to cellulosic hydrocarbon fuels. Prior to FY 2016, BETO’s state-of-technology (SOT) model assumed that any C5 sugars generated after deconstruction would be valorized to bioproducts, and any lignin would be combusted onsite for process energy.³⁰

²⁹ L. Tao, D. Schell, R. Davis, E. Tan, R. Elander, A. Bratis, *NREL 2012 Achievement of Ethanol Cost Targets: Biochemical Ethanol Fermentation via Dilute-Acid Pretreatment and Enzymatic Hydrolysis of Corn Stover* (Golden, CO: National Renewable Energy Laboratory, April 2014), NREL/TP-5100-61563, <https://www.nrel.gov/docs/fy14osti/61563.pdf>.

³⁰ U.S. Department of Energy, Bioenergy Technologies Office (BETO), *Multi-Year Program Plan* (BETO, March 2015), https://www.energy.gov/sites/prod/files/2015/04/f22/mypp_beto_march2015.pdf.

Based on advances in research, in FY 2016 BETO shifted to the assumption that all C5 and C6 sugars would be converted to hydrocarbon fuels, and the lignin would be valorized to bioproducts.³¹ Because this shift took place in the middle of the review period, a number of project descriptions and reviewer comments recognize this change in the project-specific sections below.

Regardless of which of the above two pathways a project follows, the resulting sugar-rich stream (hydrolysate) can then be fed to organisms that ferment the sugars to fuel precursor molecules. Projects that use low-temperature catalytic and mechanical systems to produce sugars (and/or other intermediates from biomass) and/or upgrade those sugars and intermediates to create finished fuel blendstocks were also presented in this session.

The SOT assumptions are mission-critical for certain national laboratory annual operating plan (AOP) projects that seek to verify BETO SOT assumptions. For competitive funding opportunity announcement (FOA) projects, there is, dependent on the FOA, much more latitude.

One of BETO's priorities is to make the biochemical conversion process more cost-effective. The process

breaks down the cell wall of plant matter by introducing enzymes or acid to extract the sugars, which are then converted to biofuels using microorganisms. The process is costly due to the complex nature of the cell wall. Lignocellulose (mainly lignin, cellulose, and hemicellulose) is the primary component of plant residues, woody materials, and grasses, and the cell wall structure of this plant matter is partially comprised of long chain sugars (carbohydrates), which can be converted into biofuels. Due to its complex structure, lignocellulose is more difficult to break down into sugars, making this material more expensive to convert into biofuels.

A key to developing cost-competitive cellulosic biofuels is reducing the processing and capital cost and improving the efficiency of separating and converting cellulosic biomass into fermentable sugars. Current R&D focuses on high-yield feedstocks, more-efficient enzymes, and more-robust microorganisms to advance biochemical conversion processes. The resulting advanced biochemical conversion technologies will increase fuel yields in integrated biorefineries—facilities that combine conversion capabilities with heat and power efficiencies to produce fuel and products.

BIOCHEMICAL CONVERSION R&D REVIEW PANEL

Name	Affiliation
Suzanne Lantz*	DuPont
Yoram Barak	BASF
Joseph Bozell	University of Tennessee
Jamie Ryding	Corvia Biotechnology Group
Steve Van Dien	Genomatica

*Lead Reviewer

³¹ U.S. Department of Energy, Bioenergy Technologies Office (BETO), *Multi-Year Program Plan* (BETO, March 2016), https://energy.gov/sites/prod/files/2016/07/f33/mypp_march2016.pdf.

TECHNOLOGY AREA SCORE RESULTS

Average Weighted Scores by Project

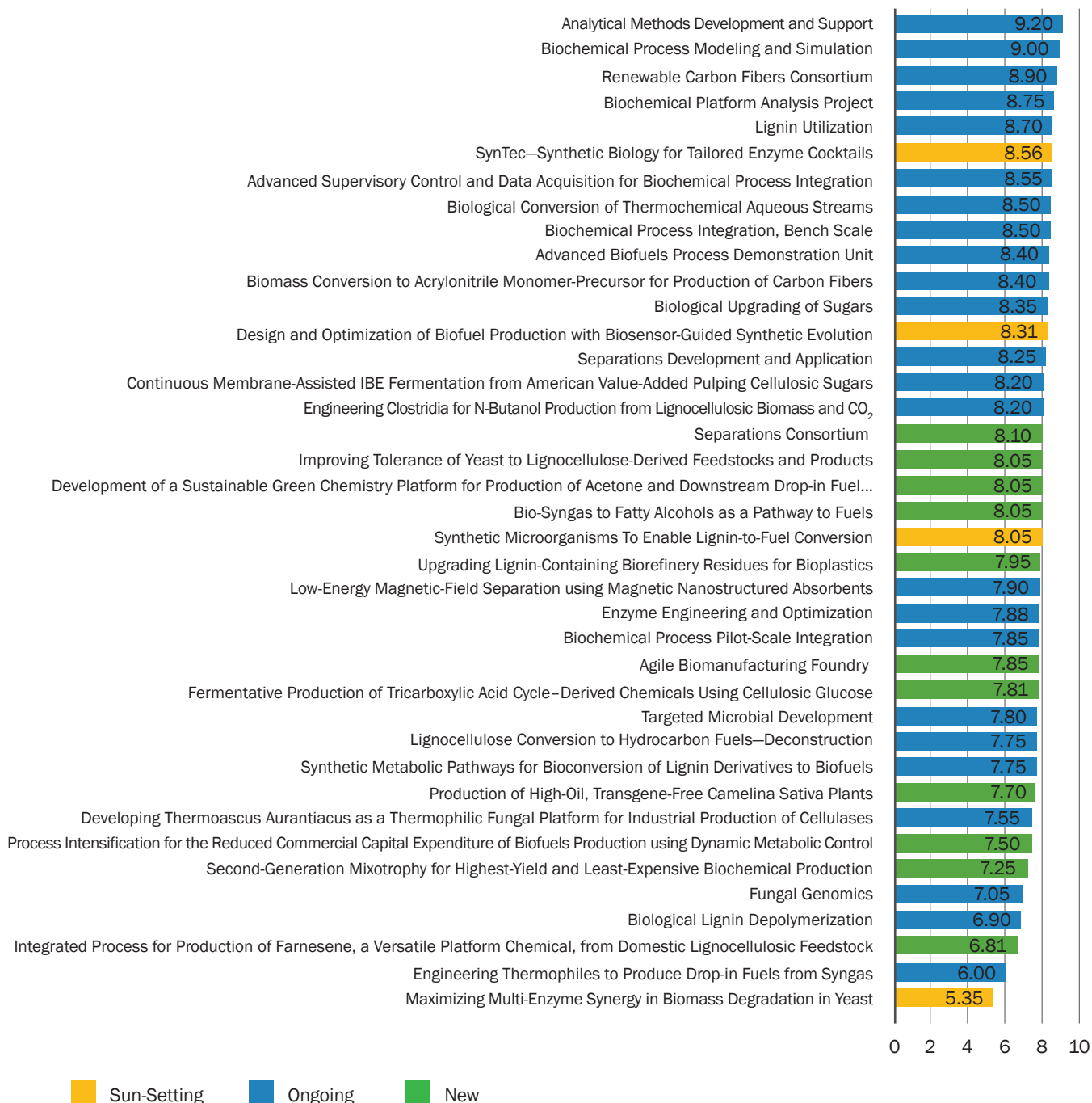

BIOCHEMICAL CONVERSION R&D REVIEW PANEL SUMMARY REPORT

*Prepared by the Biochemical Conversion R&D
Review Panel*

Impact

In its 2016 Multi-Year Program Plan (MYPP), BETO outlined approaches and targets for “enabling deployment of increasing amounts of biofuels, bioproducts, and biopower” and recognized the need for value-added co-products, from lignin or upgrading of sugars, to meet their stated goal of \$3 minimum fuel selling price (MFSP)/gasoline gallon equivalent (gge). A strength of the Biochemical Conversion Technology Area is the development of clear price and performance targets. BETO put a stake in the ground and challenged the projects to demonstrate (verify) production of hydrocarbon fuels at \$3.00/gge by 2022. The entire BETO research team in the field understands and acknowledges this goal, which is important as part of generating a cohesive program. The Review Panel was particularly impressed with how the National Renewable Energy Laboratory (NREL) team was working together and fully engaged with this target. It was interesting to observe that presentations from other national laboratories were well done, but did not display the same integration within the larger program.

The 2015 Review Panel expressed a concern that the singular focus on relatively near-term (2020/2022) goals might limit project diversity. With that constraint, the 2017 Panel felt that projects were undertaking a diverse array of approaches to achieve BETO goals. A variety of carbon sources, organisms, fuel molecules, and chemical co-products were covered by the various projects. Thus, BETO is not placing all of its bets on one process at this stage. There will necessarily be process down-selections to take those with the highest likelihood of success to the validation stage. Some projects, particularly at the

national laboratories, may need to converge and pool efforts to deliver one or two processes to validation. There may be new FOAs in the future, pending appropriations; the Review Panel is not privy to the goals of those opportunities, but they may be more future-focused to refill the pipeline or to improve upon promising technologies that will not meet the 2020/2022 timeframe.

Strengths

The projects that ranked highest were generally core and consortia projects that have broad impact across BETO, and indeed, the industry at large. The impact of the core projects (i.e., facilities/resources including process integration, bench- and pilot-scale fermentation, and analytical and computational support) is program-wide. These projects develop and implement new standard procedures, making relevant benchmarking and comparison possible. In the case of Analytical Methods Development and Support, the impact extends industry-wide. The laboratory analytical procedures (LAPs) have been downloaded and quoted tens of thousands of times and provide a uniform basis for comparison of results. They support projects with reliable and reproducible data, which is not a trivial task. The entry of this team into the D3 Renewable Identification Number “pathway” arena with the U.S. Environmental Protection Agency is a good example of an area that desperately needs standardization. Analytical Methods Development and Support has the respect and reputation needed to deliver a solution that industry, government, and all concerned will accept. Biochemical Process Modeling and Simulation has specialized expertise in modeling and simulation, which supports multiple protein engineering and process development projects by targeting and guiding laboratory work to the areas with the highest probability of success.

The consortia are relatively new, and the Review Panel anticipates significant impact will be in the future (see further discussion in the “Synergies” section).

The renewed focus on making chemical products in parallel to fuel is critical and will play a major role in developing a strong biorefining industry. The Panel recognized the progress made in lignin conversion research, which is addressing BETO's focus on co-products as an economic necessity. The two most relevant lignin valorization projects were Lignin Utilization (see further discussion under "Innovation") and Synthetic Microorganisms To Enable Lignin-to-Fuel Conversion (see further discussion under "Commercialization"). The ultimate value will be determined by industry participation and acceptance, but it is entirely appropriate for the BETO portfolio to include and drive this research in these early stages. At least one panelist questioned the focus on adipic acid from lignin and encouraged flexibility, or even a multi-product stream (biorefinery model more like a petrochemical refinery).

The highest-ranking industrial presentation was Novozymes' enzyme engineering effort (SynTec—Synthetic Biology for Tailored Enzyme Cocktails), and Lygos' technology development (Design and Optimization of a Biochemical Production Platform with Biosensor-Guided Synthetic Evolution) for malonic acid production (see further discussion under "Commercialization"). These are good examples of BETO encouraging innovation and supporting pre-commercial development, respectively.

Several projects did a good job of presenting metrics, including titer, rate, and yield (TRY) targets and achievements—NREL's Targeted Microbial Development, Ohio State University's Engineering Clostridia for n-Butanol Production from Lignocellulosic Biomass and Carbon Dioxide (CO₂), NREL's Lignin Utilization, and American Process Inc.'s Continuous Membrane Assisted IBE Fermentation from American Value-Added Pulping Cellulosic Sugars.

Weaknesses

The projects developing fungal strains, particularly filamentous fungi, could benefit from a working group, or a

consortia-type organization, to share knowledge and experience. A more consolidated effort with a critical mass of expertise could help to move these efforts along more efficiently. This was also identified as a weakness by the 2015 Review Panel. The objectives of the filamentous fungi projects are different but the tools, strains, and know-how are highly related. The same may be said for the yeast projects. Both groups should keep in touch with the Agile Biomanufacturing Foundry (Agile Bio-Foundry) as they evaluate candidate host strains.

The Kiverdi project (Engineering Thermophiles To Produce Drop-in Fuels from Syngas) was organized as a nice collaboration with NREL, but the false starts related to host selection and the overall challenges of the project make it unlikely to deliver on BETO metrics. It was unclear to the Review Panel whether incubator projects such as this were subject to validation and held to the BETO \$3/gge metric. The Panel expressed concern about the techno-economic suitability of the project, and some level of pre-project validation might have caught the initial issues related to unsuitability of the host strain. No target, revised target, or current metrics were presented, and the presenter was unable to state targets when queried. Some nice methods were ultimately developed, but this project is at a basic research stage.

The J. Craig Venter Institute project (Maximizing Multi-Enzyme Synergy in Biomass Degradation in Yeast) presented limited progress in a sun-setting project. The 2015 Review Panel recommended a departure from the planned consolidated bioprocessing (CBP) approach, which may have slowed progress. There were nice technological achievements, but the performance target was not met and the project is far from BETO metrics. The technology approach is similar to what Novozymes successfully demonstrated for screening in their BETO project reviewed in this same session. The project team is looking for future industrial partnership, which could help to validate the approach and provide needed feedback related to techno-economics.

Innovation

Although there is a long history of lignin research, the projects using lignin as a substrate for co-products are targeting the biggest challenge and opportunity in the lignocellulosic value chain. The 2015 Review Panel identified lignolytic enzyme research as an area requiring greater emphasis, and BETO responded. Some projects have taken more successful approaches than others, but this is still an exploratory stage in lignin upgrading R&D. The Lignin Utilization project was ranked highly and takes advantage of oxidative depolymerization, followed by biological conversion to a chemical intermediate. Reasonable progress is being made on mono-lignin compounds. Respecting the integrated nature of this work, the team is well-organized and collaborating with pretreatment, microbial development, and separations projects. There is also a significant analytical effort to characterize the milieu that is lignin. The Panel had some concerns about the choice of alkaline pretreated lignin (basically deacetylated lignin) as a new NREL standard substrate (compared with the historical diluted-acid pretreated corn stover lignin industry standard), but as there is no industry convergence at this stage, this material is acceptable for demonstration of possible opportunities.

The Renewable Carbon Fiber Consortium was highly ranked and considered to be an exciting new product opportunity in sugar upgrading, to bio-acrylonitrile. The product choice, techno-economic analysis (TEA), challenges, and approach were well-presented, and a balanced team of national laboratories, academics, and industry are participating in the project. The use of real biomass-derived sugars from Biochemtex and NREL hydrolysates is a strength of this program and demonstrates the use of actual biorefinery material. The Panel expressed some concerns regarding whether this ambitious project fits the BETO 2022 metric, but the Panel is very supportive of the work continuing.

More new project concepts might be developed with increased use of laboratory-directed R&D—congres-

sionally authorized funds that the national laboratories have discretion to use on high-risk seed projects (sometimes BETO AOPs have evolved from laboratory-directed R&D projects), creating a path to develop sufficient data for some projects to enter the BETO Biochemical Conversion portfolio.

Synergies

The assembly of new subject-centered consortia is effectively taking advantage of technological synergies across the platform. The organization into consortia helps the national laboratories be more efficient in their research, pooling expertise and avoiding redundancy, while also encouraging a broader perspective on problem-solving across different processes and identification of common problems (particularly for the Separations Consortium). It also provides a central point of contact for industry, allowing companies to more easily find expertise across the national laboratories. The Review Panel expressed some concerns about coordination between geographically distant research groups, and the various consortia are taking appropriate steps to manage this challenge.

Some of the national laboratories clearly have core skills that can be used by industry—particularly the process modeling group and the analytical group at NREL, and the supervisory control and data acquisition (SCADA) effort at Pacific Northwest National Laboratory (PNNL). For these, outreach and dissemination are critical, with the Analytical Methods Development and Support project at NREL providing an excellent model for this in making standard methods available online.

The BETO program also has a number of groups well-equipped to handle the transition from laboratory work to several levels of bench- and large-scale operation. This is another strength and a valuable resource for demonstrating industrial utility. The program would be further strengthened if the coordination between the Advanced Biofuels Process Demonstration Unit (AB-PDU) and Biochemical Process Pilot-Scale Integration

(NREL) was improved, as they seem to be operating independently. Impact could be enhanced by identifying a central point of contact to help define where a scale-up project might best be located.

This review included three filamentous fungi platform development projects at three national laboratories. Communication and coordination between these groups in a working group or consortium was identified as a potential area for improvement.

Focus

Technology Gaps

The 2015 Review Panel identified reactor design and aeration design as technological gaps that could use focused attention. These gaps remain in 2017, are still highly relevant, and would impact projects across the portfolio.

Standard Materials

Perhaps there could be more emphasis on the national laboratories (or even contract research organizations) producing generally applicable material like platform strains or software, with an emphasis on providing “open-source” material for the public domain. Examples include Analytical Methods Development and Support’s LAPs and NREL’s acid-pretreated corn stover, which became industry standards. Explicitly structuring some future FOAs to develop open-source materials might be a way to address this gap. The Agile BioFoundry is currently pursuing a licensing model, but the Review Panel would encourage BETO and the national laboratories to consider making the expression pipeline open source. For national laboratory projects, perhaps there should be a requirement for the project plan to explicitly identify deliverables that will be released for public use (strains, tools, reports, etc.).

Biorefinery Scenario

The renewed focus on making chemical products in parallel to fuel is critical and will play a major role in developing a strong biorefining industry. Within the program, however, the choice of adipic acid from lignin seems arbitrary. While it may be an excellent target, there are many structures that meet the selection criteria. It may be counterproductive and premature to pre-identify a specific structure before there is an understanding of the selective transformation of something as complex as lignin. It might make more sense to focus on lignin conversion as a broad technology. There has been excellent progress, but placing all bets on one structure seems limiting. It would be useful to see how the economics change if lignin is taken to compounds X and Y, more like a petrochemical refinery scenario.

Technology Communication

The BETO portfolio encompasses technology development that should be communicated beyond peer-reviewed publications and conferences. It could be useful for a national laboratory to give a full picture of successes and failures in a report, webinar, or newsletter rather than publish a journal article covering only positive results. Perhaps a plan for dissemination of information should be a requirement at the beginning of the project (with an opt-out for companies with confidentiality requirements).

Commercialization

Strengths

The sun-setting Lygos project, Design and Optimization of a Biochemical Production Platform with Biosensor-Guided Synthetic Evolution, is a good example of a combination of valid commercial target and development of core technology. This is the type of effort that is essential for BETO to reach its goal of fostering the

development of new technology capable of making a material difference to reliance on foreign oil and petrochemicals. The project was built around bio-malonic acid as a target (a DOE top-30 molecule) and enabled development of a novel biosensor for rapid screening. The approach was a combination of computational design, high-throughput screening, and bench-top fermentation, transitioning to scale-up at the ABPDU. Overall, this was a nicely organized project from bench-top to small-pilot operation using hydrolysate and capitalization of the ABPDU to demonstrate higher-volume malonic production. This small company is progressing towards commercialization and it seems to have made excellent use of BETO funds to develop a high-performing platform for strain generation and screening. The Review Panel did question the market size and whether TEAs were available but understands that cost data for a commercial venture are confidential.

The ABPDU provides scale-up and commercialization support for a variety of projects relevant to the bioeconomy. As a bioprocess research incubator, it is a one-stop shop that includes pretreatment, fermentation, recovery, catalysis, and analysis with a stated goal of one commercial outcome per year. One customer has commercialized a product, and three are in pre-commercial prototyping. The NREL bench- and pilot-scale laboratories also partner with companies and provide scale-up support and expertise. Communication and coordination between these facilities was identified as an area for improvement.

The Texas AgriLife project—Synthetic Microorganisms to Enable Lignin-to-Fuel Conversion—has very relevant alignment with BETO’s mission of valorizing lignin. It is a nicely integrated process that offers routes to convert lignin. This sun-setting project achieved technical titer targets with real biorefinery waste, and it is a nice demonstration of omics-guided strain design for both laccase production and polyhydroxyalkanoate (PHA) production by *Rhodococcus opacus*. The work has attracted potential licensees.

Weaknesses

Quantitative targets, and progress toward those targets, were often difficult to ascertain from the presentations. Although the use of TEAs was mentioned in nearly every presentation, the results and implications were rarely shown. Commercial partners such as J. Craig Venter Institute, Kiverdi, and Amyris presented few TRY targets or SOT. A suggestion for commercial entities would be to present relative improvement targets, as Novozymes did. The Texas AgriLife project is one example in which the Review Panel struggled to get a good sense of where the project stands with regard to original goals, as well as how much of a gap lies between the current process and economic viability. Although it has attracted potential licensees and met titer targets, the relevance of the targets and economic viability of the project were not clear in the review. To date, the Panel is unaware of much PHA production by fermentation because of the cost (e.g., Metabolix efforts). The project team is aware of the history, and a commercialization partner, ICM, will likely enforce diligence in the TEA.

Recommendations

Recommendation 1: Increase Project Management Rigor

Improve Consistent Use of TEAs and Quantitative Tracking of Progress. The extent to which the projects used project management tools was variable. The Review Panel recommends more critical project management based on TEA-guided milestones and measurable progress toward goals. A more uniform tracking of SOT progress over time and against milestones would benefit both the reviewers and the project. There may be opportunities for BETO to strengthen the projects themselves by increasing the requirements for timelines, risk registers, responsibility assignment matrix (e.g., RACI – responsible, accountable, consulted, informed) charts, key performance indicators, milestones, stringent go/no-go decision points, or similar tools, to be shown clearly in the pre-

sentations and referenced in the regular check-in meetings. There is also an opportunity to be more explicit in dividing milestones from goals. For example, a milestone could be “complete testing of 15 new cellulase enzyme cocktails by Quarter 4,” and then once could attach it to the broader goal, “achieve 100 g/L of glucose.”

TEA usage has increased since previous reviews but was inconsistent. TEA should be seen as an essential tool for feeding back to the technology development team (and BETO) and modeling the impact that process changes have on the overall economics—but respecting that the rigor will be different for a technology readiness level (TRL) 2 project versus TRL 6. It seemed that some of the project TEAs were made to fit the target, rather than judged against it. It should also be useful to show how success in one or more of the TRY levers (increasing titer, rate, or yield) affects the TEA. Some projects were waiting for this or that accomplishment before conducting a TEA, but assumptions must have been included in the FOA proposal to show that the \$3/gge target was achievable. BETO might provide a standard TEA table, for example, for TRY-related projects that could be tracked throughout the project. The Review Panel recognizes that one table will not fit all projects and all stages. Consistent use of TEAs and a desire to see progress tracked throughout the project cycle were also recommendations of the 2015 Review Panel.

The Review Panel expressed a concern that a few PIs are leading a lot of projects or sub-projects, and that even the most talented scientist may struggle to give sufficient time to each project unless there are management levels that allow this to work efficiently. Perhaps a check could be made at the funding time and periodically afterwards on the percentage of the project manager’s time devoted to the project.

Consider Alternative Evaluation Process for Core Operations Teams at National Laboratories. Critical support groups (e.g., analytics, pilot plant, bench-scale validation, modeling, separation, etc.) should not have the same cycle as research projects for evaluation. The efforts

of these core technology groups are extremely valuable to the BETO activities, as reflected in many high rankings. However, they are dependent on the efforts and research of “customer projects” to define and carry out their tasks, and they seem to have a limited number of projects of their own. Project start and end dates (e.g., 3-year project cycles) are irrelevant for core services. Using the same criteria for these groups as for research projects may not accurately represent their important contributions, and may indeed be an unnecessary distraction.

Explain Multiple FOAs Represented in Peer Review.

There was some confusion amongst the Review Panel regarding which projects were funded by which FOA and whether they should be held to the MYPP 2022 MFSP metrics. An example was the Amyris project for farnesene production from lignocellulosic sugars, which has a very high cost target relative to BETO fuel goals for 2022, but is relevant for non-fuel markets. Further, although it is a logical next step to evolve the process from Brazilian cane sugar to domestic lignocellulosic sugar, the targets did not seem very rigorous given Amyris’ experience producing farnesene from cane sugar and Renmatix delivering clean sugars. The project received some low relevance scores in a fuel context and an overall low ranking, even though the probability of success on the stated goals is high.

Recommendation 2: Continue To Support Consortia Organization in Specific Technology Areas

The potential of the consortia should be realized in the near future. The Separations Consortium and SCA-DA projects are addressing practical current industrial challenges. The Renewable Carbon Fibers Consortium is developing new routes to useful chemicals. The Agile BioFoundry seeks to deliver licensable host strains and design-build-test-learn pipeline enhancements. Such organization helps the national laboratories be more efficient in their research, pooling expertise and avoiding redundancy, while also encouraging a broader perspective on problem-solving across different processes and

identification of common problems. It also provides a central point of contact for industry, allowing companies to more easily find expertise across the national laboratories. Other research areas that could benefit from central steering and a critical mass of expertise are fungal strain development and lignin depolymerization.

Recommendation 3: Encourage Use of Industrial Advisory Boards and Partnerships

The consortia formed industry advisory boards, and a few of the individual national laboratory projects did as well. Some notable projects could have benefitted from

guidance from someone with specific domain expertise, including Enzyme Engineering and Optimization (directed evolution of a cellulase in yeast), Biological Lignin Depolymerization, and the J. Craig Venter Institute project. When potential industrial partners are identified but decline to participate in funding opportunities as full partners, they may be receptive to an advisory role to help the project set realistic targets, obtain relevant materials, gain valuable insight, and envision practical process application.

BIOCHEMICAL CONVERSION R&D PROGRAMMATIC RESPONSE

Introduction/Overview

The program would like to thank the reviewers for their time and effort on the Panel as well as for their thoughtful recommendations. The reviewers identified the focus of all of the Biochemical Conversion projects on a \$3/gge cost goal as a strength of the portfolio. BETO agrees that cost targets help to focus our R&D efforts on meaningful pathways with near-term impact. Additionally, the Panel noted that the 2015 reviewers identified the potential for a lack of project diversity as an area of concern if efforts were too focused on the 2022 cost target, but they felt that despite focus on the cost goal, project diversity was adequately maintained.

The Panel identified reactor design and aeration design as potential technology gaps. BETO has funded work on aeration design in the past but is moving the focus of the Biochemical Conversion Technology Area beyond aerated reactors, so this work will likely slow in the future. The reviewers also identified a need for standardized materials, including feedstocks, strains, and software, to be

used by other laboratories as well as industry in a publicly available manner. BETO hopes to make strains available through the Agile BioFoundry in as freely available a manner as possible. The national laboratories already provide resources like cellulosic sugars to industrial and laboratory partners, but BETO will look into expanding this effort. The Review Panel commented that, although pursuing a strategy that relies on chemical production is the right path, it is critical to not get locked into one product like adipic acid too early. We agree with this recommendation and are pursuing a variety of example products.

The Panel's recommendation to continue pursuing lignin valorization as a core program strategy is appreciated, and BETO is expanding its lignin valorization work in FY 2018. BETO is also developing plans to work on a variety of lignin substrates, including acid pre-treated substrates, in addition to deacetylated and mechanically refined – enzymatically hydrolyzed substrates. The Panel also felt that renewed focus on making chemical products in parallel to fuels was the right direction for the program, particularly noting the lignin valorization projects. BETO plans to expand this work in the future given the critical role of lignin valorization in cost-competitive fuel production from biochemical pathways.

The following sections specifically address the top three recommendations from the Review Panel.

Recommendation 1: Increase Project Management Rigor

The program is in agreement with the reviewers that stronger metrics are needed to track progress across projects. We have made this an active area of focus since the 2015 Project Peer Review and, as the reviewers noted in the first section, we have made progress in this area, especially at the national laboratories. We will continue to work to create clear, quantitative goals across all projects, including competitive projects.

The reviewers recommended that BETO consider the commitment level of project PIs in the portfolio. BETO will monitor this and ask junior scientists to serve as PIs where appropriate in the portfolio to ensure adequate effort is given to all national laboratory projects by the PI of record. The national laboratory projects that serve as enabling capabilities and provide core services will also be considered for alternative evaluation, including the expanded use of joint milestones as recommended.

We also share the reviewers' concerns about a lack of consistent TEA methodology across projects and will work with the validation team to help standardize these to the extent it makes sense for a given product or pathway.

In addition, the Panel recommended validations and better alignment of project goals for all competitive projects, including incubator projects. BETO will work to address this in future funding opportunities and will work with the validation team on a tiered approach to validations of projects of different sizes. A concerted effort will also be made at the next Project Peer Review to allow the reviewers easy access to explanations of the goals of the different FOAs the Panel will evaluate.

Recommendation 2: Continue To Support Consortia Organization in Specific Technology Areas

The reviewers recommended continued support for the consortia structure pioneered after the 2015 Project Peer Review. Active consortia will continue to be refined and strengthened, and new consortia will be planned in areas such as fungal genomics, where appropriate given subject matter and resources. In addition, BETO intends to better coordinate management structures of consortia and encourage the sharing of best practices amongst the various efforts.

Recommendation 3: Encourage Use of Industrial Advisory Boards and Partnerships

Industrial advisory boards are being emphasized in all current and future consortia. Larger project areas will work to develop plans to better engage industry in FY 2018. We cannot force competitive projects to include industry advisory board input, but we will emphasize industrially-relevant reviewers in the review process.

The Panel also noted that the scale-up facilities that BETO operates are a valuable part of the portfolio and suggested that a coordinated effort for these facilities to engage with industry would be helpful. We agree that the ABPDU is an excellent resource, and we will continue to encourage them to partner with industry. Additional industrial engagement through the Agile BioFoundry with the ABPDU and other scale-up facilities is underway, and BETO will attempt to better highlight these capabilities through a request for information or other means going forward.

PRODUCTION OF HIGH-OIL, TRANSGENE FREE CAMELINA SATIVA PLANTS

(WBS #: 1.1.1.104)

Project Description

The objective of this project is to develop a Camelina sativa feedstock with significantly increased seed yield and oil content to maximize oil yields per acre. Camelina is an oilseed crop with high potential as a bioenergy feedstock due to its high oil content and low inputs for cultivation. To accelerate market entry, a next-generation technology is being used to develop genetically modified organism-free plants that are expected to provide an expedited path through regulatory approval.

The program has two oil production benchmarks: (1) increase production of seed to 2,500 pounds/acre with seed containing 45% oil, and (2) increase production

Recipient:	Yield10 Bioscience
Principal Investigator:	Kristi Snell
Project Dates:	10/1/2015–9/30/2017
Project Category:	New
Project Type:	FY 2013—Incubator: DE-FOA-0000974
Total DOE Funding:	\$1,996,598

of seed to 3,500 pounds/acre with seed containing 60% oil. Hitting the first benchmark will significantly expand the potential of Camelina as a crop and will provide the profitability necessary to incentivize farmers to grow Camelina, resulting in the production of renewable feedstock for the biobased energy and chemical industries. The second benchmark (3,500 pounds of seed/acre with 60% oil content) will have a significant impact on the availability of renewable Camelina oil for the biodiesel and aviation fuel markets. Because the final plants produced in this program will not contain transgenic DNA, they are expected to have an expedited approval path

Weighted Project Score: 7.7

Weighting: Approach–25%; Relevance–25%; Accomplishments and Progress–50%.

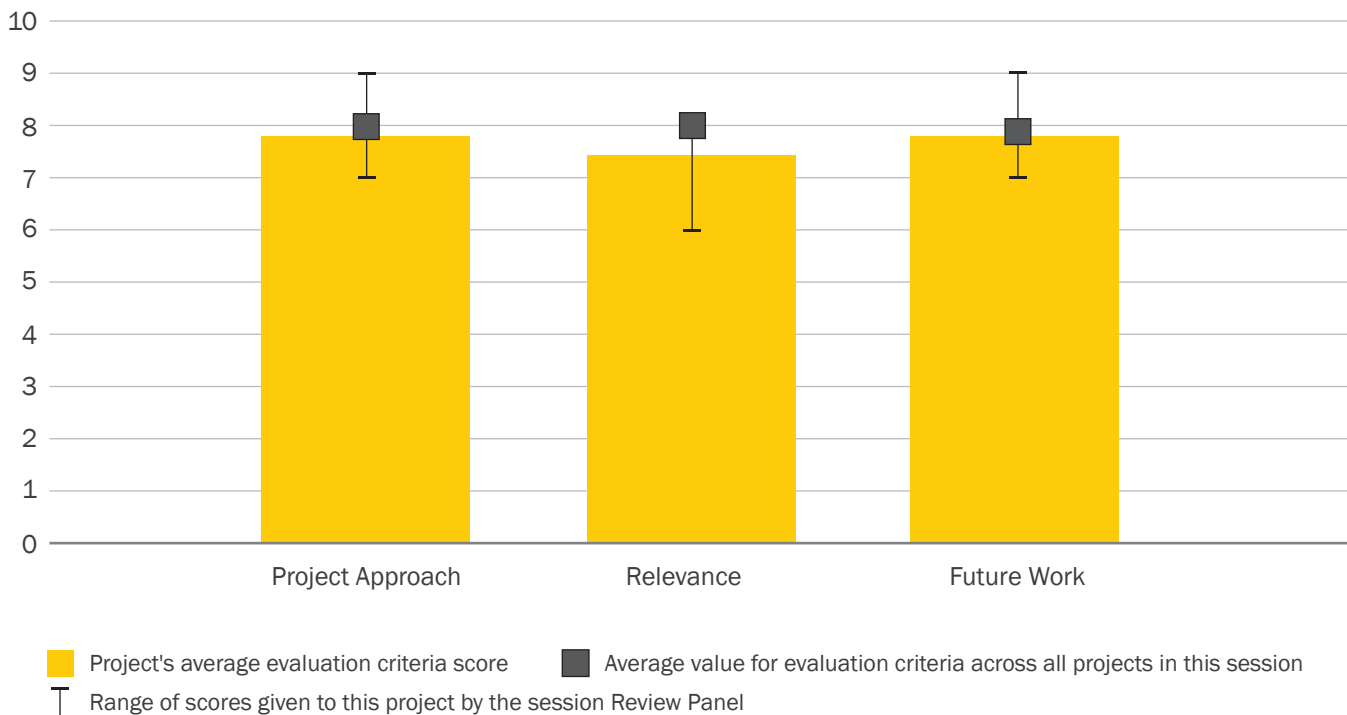

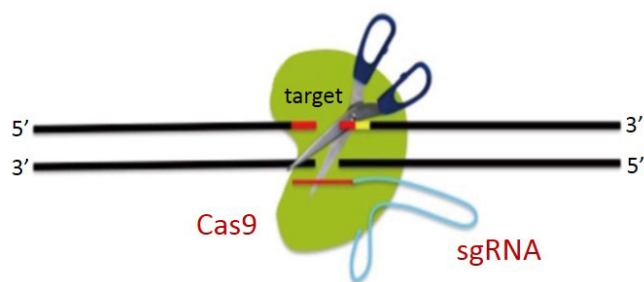

through regulatory agencies, significantly reducing costs and time to commercialization. The technology developed in this program will also be relevant to increasing seed and oil yield in related oilseed crops, such as canola.

Overall Impressions

- In a general sense, there would seem to be value in developing an oilseed crop specifically for biofuels, removing concerns about edible oil characteristics and focusing purely on lipid yields. Also, removing the concern about lines of bioenergy oilseed crops crossing into lines for oilseed crops for food production seems significant. It would have been good to see the agronomic benefits of Camelina over other crops explained better in the presentation—it may not be a food crop, but if it competes for the same land as a food crop, there is still a food versus fuel debate. Does it show higher yields than competing oilseed crops or other crops on marginal or drought-prone land? How do the inputs compare?

The approach to identification of specific genetic targets was not shown the presentation. This may be due to the proprietary nature of the project, but it makes it difficult to assess how likely the project is to succeed. All we may glean from the presentation is that the project team has made some genetic changes using CRISPR/Cas9 and the agrobacterium system. We are left with the question of how far can targeted gene disruption alone go to improve oil yields in the plant?

- The PIs are carrying out a straightforward effort to develop Camelina as a new bioenergy crop and

supply for the biorefinery. The scientific approaches are solid, but the project faces a considerable challenge in convincing farmers to grow a crop at levels sufficient to make a difference in the fuel market. Much more detail about the path to commercialization would strengthen this project: where will the 13 million acres be located? What proof is there that farmers would actually switch to Camelina?

- The goal is to develop *Camelina sativa* plants with higher oil yield, with no foreign genes so it could be easier to get through regulatory process. Better oil yield will make the cost low enough to provide enough farmer profit to make it worth planting. Plant engineering is slow, but the team has made good progress so far and appears to have a solid metabolic engineering approach. They have also advanced the CRISPR/Cas9 approach in plants, which could impact the larger plant genetics community. Targets are reasonably set. Bigger than the technical challenge may be getting the improved seed into the market. It is not clear if the team has good channels to the market and distribution.
- Camelina oil and seed yield improvements should be valuable to current Camelina growers and will potentially expand the feedstock supply for bioenergy to new growers. Camelina has the advantage of being a low-input, non-food-competing crop.
- The project is well-structured and managed. There is good collaboration between North Carolina State and Yield10 to bring this novel genome-editing, technology-driven improvement of Camelina as an energy crop. Yield10 will continue this project after the incubation period to get the expected 3,500 pounds/acre seeds with high oil content, which is needed to enable the farmer to grow camelina with more profit in a dual season approach where applicable. The crop doesn't compete on arable land or divert resources from the food chain and, as such, fits very well with BETO's mission; if successful, it will have overall positive societal impact.

PI Response to Reviewer Comments

- Commercialization path: Recognizing the highly-concentrated nature of the seed business, Yield10 does not plan to become a seed company. Instead, the company plans to fill an innovation gap in the agricultural biotechnology space due to (1) reduced investment in basic R&D from ongoing agricultural sector consolidation and restructuring, and (2) the urgent need for new technology approaches. Yield10's role is to discover, optimize, and translate its yield trait innovations into crops to demonstrate their economic value to the growers and seed companies. We are essentially in the business of creating high-value assets in the form of proprietary yield technologies and de-risking them by progressing along the commercial development process to complete multi-year field trials. A third-party agricultural company would then either license or acquire rights to Yield10's technology for commercialization.

We have, however, outlined a three-phase commercialization plan that could be implemented at a low capital cost to commercialize the BETO lines. This plan would be used to demonstrate the value proposition of the improved Camelina seed lines necessary for investment in larger-scale seed-crushing infrastructure.

- In Phase 1, seed from 10,000 acres from contract growth arrangements with farmers would be generated to supply feedstock for an entry point to a U.S. commercial business (see table below). Contract growth on 10,000 acres with a line producing the program intermediate target yield (2,500 pounds/acre and 45% oil) can be initiated with 100 farmers, who will each dedicate 100 acres (see table below). Interested crushing, biodiesel, and feed companies will be identified and off-take agreements negotiated for sale of the resulting oil and meal. This will allow a quick, practical start to the business with proper distribution channels already in place.
- In Phase 2, Camelina production would be expanded to 50,000 acres, with off-take agreements negotiated for sale of the resulting oil and meal. The results from the Phase 2 operations would be used to attract financing for a U.S.-based facility.
- In Phase 3, a dedicated oilseed-crushing plant would be constructed with the capacity to process seed grown on 100,000 acres. This is enough oil to produce approximately 12,418,830 gallons of biodiesel (conversion factor of 7.7 pounds of oil per gallon of biodiesel, based on generalized information for canola oil). Money for constructing this initial plant could be obtained through financing or through a partnership or joint development agreement with a larger company.

Please refer to table below, which illustrates the production potential of this three-phase commercialization plan.

	Base Case (40% oil, 1,500 pounds/acre)	Intermediate Target (45% oil, 2,500 pounds/ acre)	Final Program Target (60% oil, 3,500 pounds/ acre)
Acres	13,100,000	13,100,000	13,100,000
Seed harvested (tons)	9,825,000	16,375,000	22,925,000
Oil (tons)	3,340,500	6,263,440	11,691,750
Biodiesel (gallons)*	867,662,340	1,626,866,880	3,036,818,180
Fold increase	1	1.87	3.50

Calculations assume use of the intermediate target line (45% seed oil; 2,500 pounds of seed per acre).

- Crushing capacity assumes 300 days/year plant operating schedule.
- Yields assume 85% recovery of oil and meal from crushing and extraction.
- Assumptions for Camelina oil, meal, and seed prices are based on March 2014 canola prices: Camelina oil \$0.40/pound (canola oil \$0.43/pound); Camelina meal \$0.10/pound (canola meal, \$0.18/pound).
- Farmgate price for Camelina seed is \$0.15/pound (canola farmgate \$0.22/pound).
- Crushing and operating costs of crushing facility are \$40/ton of seed.

BIOCHEMICAL PLATFORM ANALYSIS PROJECT

(WBS#: 2.1.0.100)

Project Description

This project performs TEA to support and guide Biochemical Conversion Technology Area’s R&D efforts through using process and economic models. These models translate key process parameters into overall economics to set future R&D targets and track performance progress against those targets. BETO uses the outcomes of integrated TEA modeling to guide program plans, as do other NREL partner projects to quantify the impact of research on key technology barriers.

This work is highly relevant to BETO’s program goals in that “bottom-up” conceptual modeling conducted under the project serves as a basis for understanding the technical feasibility to meet “top-down” program cost targets. Our TEA models may be leveraged to direct

Recipient:	National Renewable Energy Laboratory
Principal Investigator:	Ryan Davis
Project Dates:	7/22/2002–9/30/2017
Project Category:	Ongoing
Project Type:	AOP
DOE Funding FY 2014:	\$750,000
DOE Funding FY 2015:	\$750,000
DOE Funding FY 2016:	\$750,000
DOE Funding FY 2017:	\$750,000

R&D towards the most economically impactful priorities by providing a framework to translate technical performance to cost reductions within a biorefinery. These efforts help to maximize efficiency of research funding and ultimately support the goal of demonstrating \$3/gge fuel cost targets by 2022.

This analysis project has made significant achievements since the 2015 Project Peer Review, including creating new TEA models to highlight the economic potential and R&D challenges for new pathway concepts to

Weighted Project Score: 8.8

Weighting: For ongoing projects, there is equal weighting across all four evaluation criteria: Approach, Relevance, Accomplishments and Progress, and Future Work.

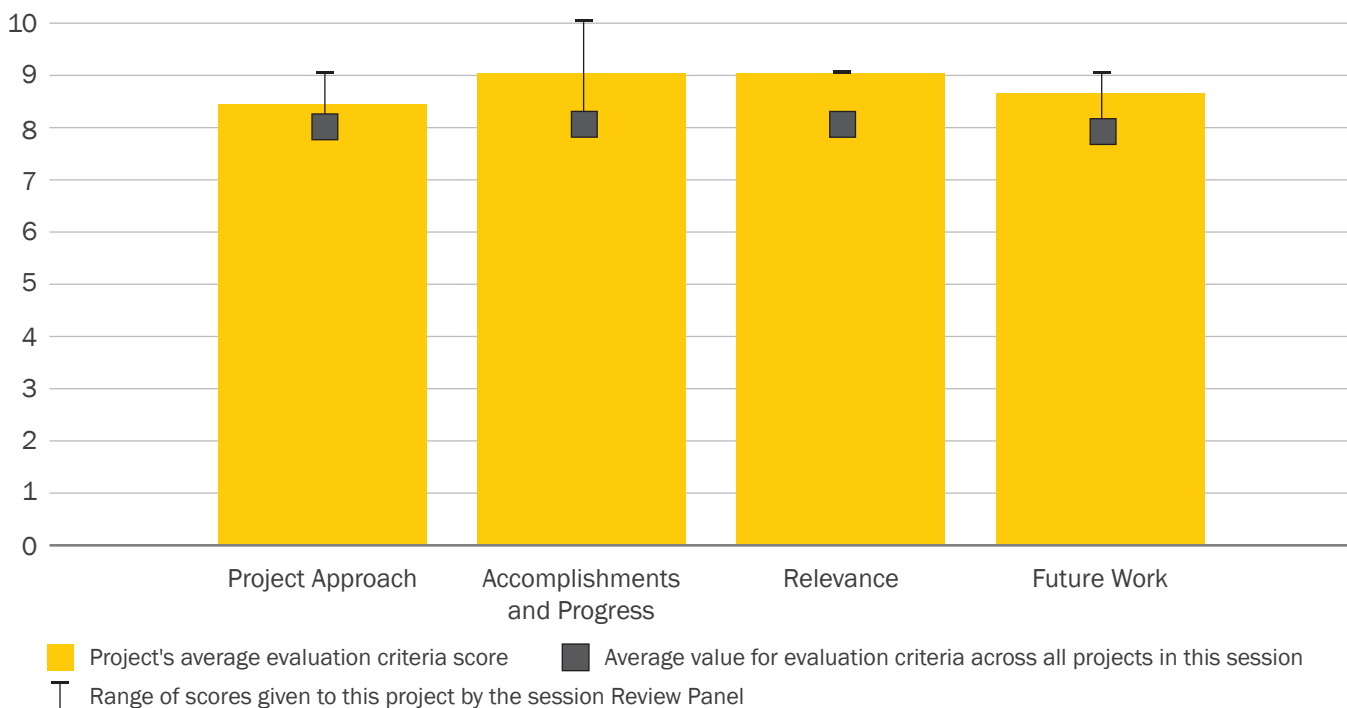



ultimately achieve 2022 program targets. This work demonstrated the ability for a range of pathway options to achieve \$3/gge, contingent upon the ability to utilize lignin for conversion to value-added co-products.

Overall Impressions

- The project is crucial to the success of the other NREL projects. Cost is often the final determinant in whether particular processes will be developed further. Providing good-quality models for processes early on will make the development work of those projects more relevant and help guide choices in where to invest time and effort experimentally.

The presentation was well put together and logical, and it came through strongly that the modeling team is well-versed in the required methodologies and is paying attention to the requirements of the other

projects. Two important aspects of the project will be (1) the interaction with the individual NREL projects (to support ongoing decision making, such as tornado plots to identify higher-value targets for cost reduction), and (2) the value provided by the project to a wider audience of stakeholders. Beyond publishing models, it may be worthwhile for the team to consider ways to help companies or other national laboratories improve their own modeling capabilities, through workshops and provision of tools. Another aspect to consider could be increasing the bandwidth of the team to allow it to provide a fee-for-service offering on similar modeling methods to other BETO funding recipients or outside companies, in a similar way to ABPDU.

A further way to help the NREL groups would be to provide a simplified version of the process cost model (e.g., a “ready reckoner” in Excel) that allows process parameters and results from experiments to be input, and then final costs to be extracted. This offers the benefit of allowing researchers to play with the numbers without requiring time from the modeling team, and it even allows researchers to use cost as the metric for modeling a response surface when varying process conditions in design of experiments.

- TEA and platform analysis is a strength of the program, as it adds credibility to BETO’s stated goal of transferring the program’s work to industrial stakeholders. Partnerships with industry will not develop without a compelling economic justification, and the program is doing an excellent job of providing these data and making sure that the team members understand the goals as research directions are chosen. Presentation of this activity could be clarified with a better description of the interplay between the many moving parts of the program (MYPP, SOT, AOP, FOA, researchers, and process engineers). They all interact and are all important, but clarification would give the outsider a better idea of program organization.

- The Biochemical Platform Analysis project is an essential component to meeting the objectives in the MYPP and essentially serves as the cornerstone to all other BETO projects. It is intended to provide high-level guidance on BETO's project portfolio, selecting the best fuel/co-product scenario, process design, and technical target metrics. The team has done a good job at this, using rigorous models and thorough data analysis. It would be helpful to understand exactly how the co-bioproduct target molecules were chosen. It seems that products with higher value and/or larger market could be identified.
- The use of TEA analysis in project management increased dramatically from 2013 to 2015 to 2017. Modeling and design cases are now key tools in tracking progress, assessing feasibility, scalability, sustainability, and economics. This platform is closely integrated with the R&D projects, particularly NREL. Communication, public transparent models, and design cases with external stakeholders are also an important role of this team, providing a common language and reality checks with industry. This team should also be involved in the continual analysis of \$3/gge reduction as a relevant target.
- Overall, this is a great project with the right infrastructure to accomplish its goals. The project can benefit from benchmarking its assumptions more critically with industry-relevant metrics where possible—perhaps through joint projects where better understanding of the cost structure can be shared.

PI Response to Reviewer Comments

- We thank the reviewers for their positive feedback in recognizing the impact of this project for BETO and the utility in guiding R&D priorities for NREL and the community. We do offer a number of different collaboration/“fee-for-service” mechanisms for partners seeking to leverage our TEA capabilities, and we have worked with numerous industry and academic groups over recent years to provide TEA/life-cycle analysis/process modeling support.

We also participate in various partnership outreach functions and have hosted visitors from industry, academia, and other national laboratories seeking to work with our TEA modeling group to better understand TEA practice. Additionally, we have made a number of our models publicly available and are working to publish others once they have been properly refined, vetted, and automated for usability.

We support the notion of exploring more simplified TEA approaches for less-developed concepts and have recently begun to act on this feedback through several mechanisms. In terms of “tools” for quicker analysis, within NREL's TEA group (with support and input from this project) we have developed a high-level qualitative framework tool to help guide R&D thinking and work prioritization. The tool is focused on identifying potential benefits and challenges for a particular concept with respect to process complexity and expected yields (primary drivers on MFSP), as well as knowns/unknowns required to run a more detailed TEA. Additionally, (also with collaboration from this project), NREL's TEA team has begun to develop a “quick turn-around analysis” tool, which takes this a step further to provide cash-flow and MFSP estimates for a process of interest, given inputs for processing costs and yields, without necessitating the use of a full Aspen Plus process simulation (although we stress the latter is still important in tracking mass and energy balances to reasonably quantify those metrics for new concepts). For novel concepts, which do not have precedent from a similar TEA pathway, our group has the capability to perform preliminary “back of the envelope” calculations, even with Aspen Plus, relatively quickly, given our proficiency in that software and preference to maintain thermodynamic rigor, which can have a large influence on overall yield/cost results.

Regarding the comment on selection of specific co-products, the primary intent of our TEA work in that respect has been to quantitatively demon-

strate the benefits that may be gained by introducing co-products as a means to reduce fuel costs and ultimately enable economic viability in a conceptual biorefinery. To date, we have approached this by reflecting co-product molecules that have been the subject of internal NREL research focus (previously succinic acid from sugars and more recently adipic acid from lignin) as representative examples to demonstrate proof-of-concept for commercially relevant high-value bioproducts, which do generally have high market volumes or potential to produce derivative products with high market volumes. This forms a basis upon which industry may build in the future for similar multi-fuel/product biorefinery concepts, recognizing that biorefineries on a national scale would target many different co-product opportunities based on the market drivers at the time.

DEVELOPING THERMOASCUS AURANTIACUS AS A THERMOPHILIC FUNGAL PLATFORM FOR INDUSTRIAL PRODUCTION OF CELLULASES

(WBS#: 2.2.3.102)

Project Description

The project objective is to develop a thermophilic fungal platform for cellulase production. Cellulases remain a significant portion of the projected cost of producing sugars from plant biomass. Reducing the cost of enzymatic hydrolysis depends on identifying more efficient enzyme preparations and hydrolysis parameters that enable cost-effective release of sugars. Thermostable cellulase mixtures that perform at higher temperatures will enable the use of high temperatures and shorter reaction times for saccharification, allowing for utilization of waste heat, lowering viscosity, and overcoming end-product inhibition.

Recipient:	Lawrence Berkeley National Laboratory
Principal Investigator:	Steve Singer
Project Dates:	10/1/2014 - 9/30/2016
Project Category:	Ongoing
Project Type:	AOP
DOE Funding FY 2014:	\$0
DOE Funding FY 2015:	\$150,000
DOE Funding FY 2016:	\$540,000
DOE Funding FY 2017:	\$540,000

In this project, the thermophilic fungus, *Thermoascus aurantiacus*, has been developed as a platform for cellulase production. Cultivations up to 20 L at ABP-DU produced high titers of cellulases using xylose and hemicellulosic hydrolysate as inducers. These cellulases demonstrated comparable performance in saccharifications of dilute acid and base-pretreated corn stover compared to commercial enzymatic mixtures. The *T. aurantiacus* cellulases were capable of maintaining that performance at higher temperatures than commercial

Weighted Project Score: 7.6

Weighting: For ongoing projects, there is equal weighting across all four evaluation criteria: Approach, Relevance, Accomplishments and Progress, and Future Work.

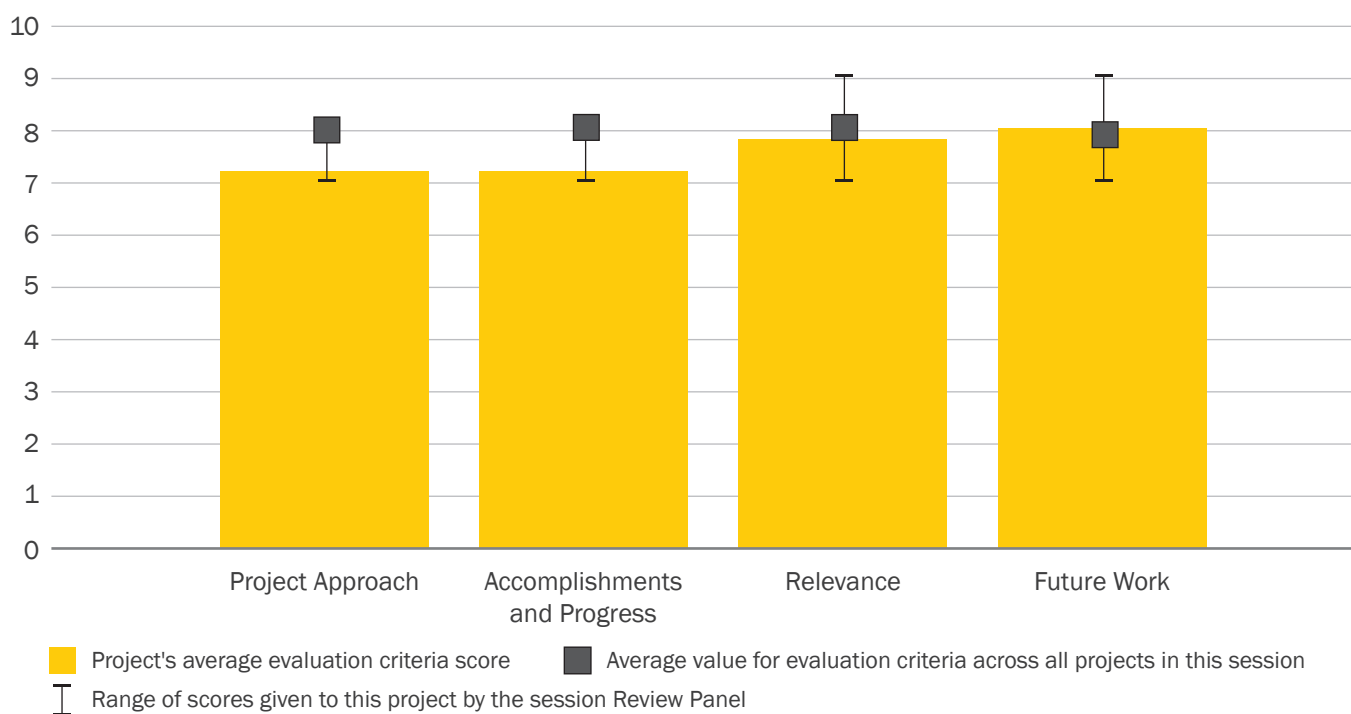



enzymes. A genetic system for targeted gene deletions was developed using *Agrobacterium*-mediated transformations. These gene deletions will serve as the basis for a hyperproduction strains that may be deployed in biorefineries where the byproducts of biomass pretreatment will be used to produce cellulases.

Overall Impressions

- Overall, I like the scope of the project a lot. Providing a thermostable enzyme mixture as a further option to industry, a higher-temperature protein production system, and the possibility of producing a full cocktail on a C5 hydrolysate stream all represent significant benefits to the cost of cellulosic processes.

There is a lot for the team to do to move this project forward, but it has a lot of potential. I would ask the BETO team to look again at the decision to pause funding for the project. Although this represents only the start of a long-term project, it does have the potential to make a step-change in the process economics. The long-term nature of developing a novel fungal system from scratch means that this is often hard to push this forward in industrial companies, and proving out the first part of the technology and perhaps releasing platform strains to industry would allow the technology to bridge that gap.

- The project appears to have identified an organism that operates at higher temperatures and is able to carry out hydrolysis of actual biorefinery hydrolysate. The protein production levels appear to be lower than needed, but the team has a plan in place to address that deficiency. However, the project is paused, so future work is not yet certain.
- The objective of this program is to develop a cellulase production organism that can leverage the C5 stream for onsite production and also enable high-temperature hydrolysis. The team has identified a promising host strain that accomplishes both these objectives. This impacts two important aspects of the MYPP: improved enzymes and utilization of C5 stream. However, more thorough TEA is needed to demonstrate that this use of C5 has a significant cost impact, as well as what the enzyme titer has to be. Also, I don't have a good feeling as to how close this is to being technically ready for commercialization.
- The discovery of C5 induction of cellulose production is very interesting. The high-temperature growth (and protein production?) of *T. aurantiacus* and the high-temperature hydrolysis performance of the enzymes have potential use. Developing this new strain for commercially relevant, scalable protein production has numerous technical challenges, including a robust fermentation process and high protein titer. A common challenge with high-temperature enzyme cocktails is that even at their optimum, they yield lower sugar titers than CTec2 (Novozymes Cellic CTec2, a commercial enzymes package for cellulosic ethanol production, launched in 2010) at its optimum, and the state-of-the-art has moved well beyond CTec2.
- The project is aiming at a needed BETO goal of developing a fungal expression system to lower enzymes production costs. Technically, the project manager is encouraged to partner even more with other fungal development projects in NREL as this can accelerate the team's R&D achievements. I would also

encourage BETO to consider a consolidated effort on fungal strains development programs. The project team has good overall understanding of the biology and developed good tools for this unique thermophilic fungal strain. It is hard to evaluate, though, how economically viable this will be concerning the short-term objectives of BETO's 2022 goals.

A thorough TEA and realistic timeframe to translate this to industrial partners should be considered. The interest from enzyme companies is understood and appreciated, but it is not clear if they will be willing to switch to such a production host for onsite production as suggested. This angle, if it can be strengthened through better economic justification, can help the project with more momentum and funding in the future. The use of C5 sugars to produce enzymes versus use for product production is good idea if the TEA merits such direction.

PI Response to Reviewer Comments

- TWe thank the reviewers for the positive comments about the progress on the project and potential for this work in the future. We are confident this early-stage work has provided the tools to rapidly increase protein titer, bioreactor performance, and genetic tractability of *T. aurantiacus*. Preliminary saccharification tests have established that the *T. aurantiacus* enzymes are competitive with enzymes from commercial mixtures on biofuel-industry relevant substrates, and this is before any optimization has been performed on the *T. aurantiacus* enzymatic mixture. The observation of C5 induction provides a unique way to make *T. aurantiacus* a platform for onsite enzyme production and will also be a driver of fundamental research to understand regulatory mechanisms for protein production in a thermophilic fungal model organism.

LIGNOCELLULOSE CONVERSION TO HYDROCARBON FUELS - DECONSTRUCTION

(WBS#: 2.2.3.105)

Project Description

Catalytic and biochemical processing of lignocellulosic sugars and sugar-derived intermediates potentially offer advantages over high-temperature pathways by allowing milder processing and by providing routes to open-chain fuel components not readily available by other means. Current deconstruction technologies, however, do not reduce ash content. Ash fouls catalysts and scales reactors and is one of the major issues that still needs resolution. Organic impurities inhibit fermentations.

The objective of this project is to develop transferable technologies to produce low-ash sugars and sugar-derived intermediates from woody, herbaceous, or other lignocellulosic biomass that can be used in biologic or

Recipient:	Pacific Northwest National Laboratory
Principal Investigator:	Mike Lilga
Project Dates:	10/1/2016–9/30/2019
Project Category:	Ongoing
Project Type:	AOP
DOE Funding FY 2014:	\$0
DOE Funding FY 2015:	\$0
DOE Funding FY 2016:	\$0
DOE Funding FY 2017:	\$200,000

catalytic processes for producing distillate-range hydrocarbon fuels, fuel blendstocks, and chemical products. Development of a new technology using biphasic deconstruction media in batch or flow reactors provides options for producing sugars and sugar oligomers or sugar-derived furan intermediates. The deconstruction technology does not require neutralization, minimizing waste, and can be recovered for reuse. Significantly, low-ash products, possibly suitable for catalytic processing, are produced. This work addresses pretreatment and deconstruction barriers by providing clean streams for

Weighted Project Score: 7.8

Weighting: For ongoing projects, there is equal weighting across all four evaluation criteria: Approach, Relevance, Accomplishments and Progress, and Future Work.

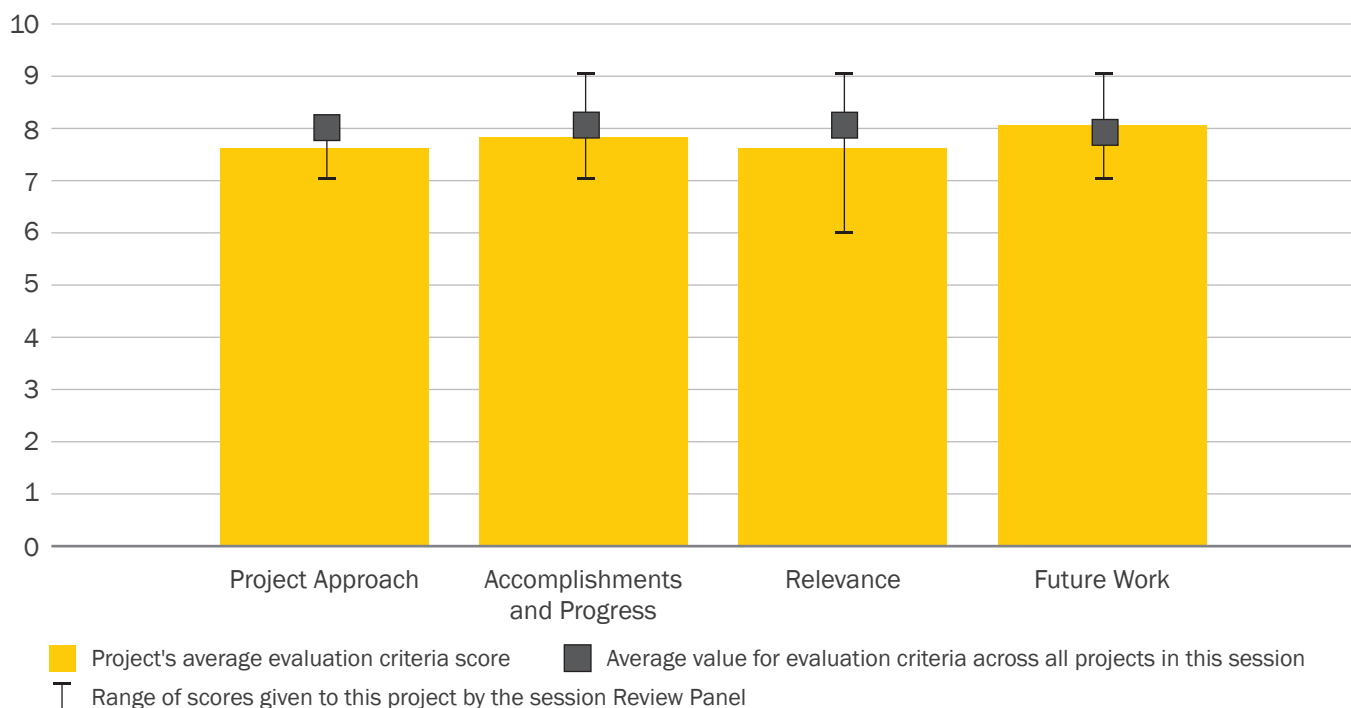

upgrading. Diverse downstream processing options are enabled, increasing the probability that new economical routes to fuels will be developed.

Overall Impressions

- The project looks interesting in producing some novel routes to deconstruction and generation of intermediates that would provide an alternative to current dilute acid/enzyme hydrolysis/fermentation to product routes.
- In such cases where there are solvents and catalysts to be recycled in the presence of biomass (e.g., the xylene/nonanoic acid combination), it would be good to have working TEA models set up, where targets for percentage recovery of these components can be assessed.
- The project is a straightforward and novel approach to biomass separation that gives good yields of sugars with low impurities. This makes the process a potential solvent-based catalyst for biomass deconstruction in the biorefinery. More details on the ability to recover and reuse solvent in these systems will strengthen understanding of this project as it is considered for larger-scale operation and testing.
- This program intends to develop two new biomass deconstruction methods that result in cleaner sugar (or sugar derivative) streams than the current dilute acid approach. Both methods have shown promising progress, but it is not clear where performance stands relative to where it needs to be. Will it require \$1 million, \$10 million, or \$100 million worth of R&D before it becomes commercial? More rigorous quantitative metrics should be set for the future. Also, the team should partner with downstream projects (like fermentation) to see how the resulting sugars perform.
- Developing a new deconstruction technology to provide low ash and clean sugars is potentially transformative, expanding downstream processing

and product opportunities. The team has made good progress demonstrating that different process designs favor either sugar or furan-type products. Reasonable cost is critical to implementation, so scaling and TEA are important future work. This may be a platform technology, but for BETO, it's important to identify a target process and demonstrate integration and <\$3/gge.

- The project made some nice progress demonstrating how to potentially reach and align the TEA-guided solutions to reality checks in the laboratory. TEA results suggest that the project's ability to reach commercial reality should be evaluated. The project team is advised to use SMART (specific, measurable, achievable, relevant, timely) goals with critical metrics to measure progress toward goals to judge where the project is benchmarked to the TEA goals. Technically the program made good findings regarding the particle size being ineffective, direct one pot reaction to furans, no need for neutralization, and ability to separate oligomers. These are all good achievements in the right direction.

PI Response to Reviewer Comments

- Thank you for the supportive comments. We also believe the technology is novel with many potential benefits, including solvent recyclability, ash removal, and the ability to choose operation conditions to produce either sugar oligomers or sugar-derived intermediates, such as furans.

TEA will be conducted throughout process development to guide research and benchmark against BETO goals and other technologies. To date, the only TEA comparison we've made is to the NREL case, which was shown in the presentation. The overall yield is most important to process economics. Sugar yield in the deconstruction portion of the process can be increased by a de-lignification pretreatment step, which we hope to conduct this fiscal year (FY 2017). The efficiency of solvent recovery

is also an important input to future TEAs. At this time, we have not evaluated solvent recovery and the degree of make-up that might be needed.

In addition, the amount of water used in deconstruction is an important factor in process economics. While we typically run at about a 1:1 H₂O: organic volume ratio, we have also explored ratios as low as 0.14:1 and 0.018:1. At 160°C, 21.5 mL H₂O/150 mL xylene (0.14 vol. ratio) gave 27% weight reduction—the same as when using 100 mL H₂O/150 mL xylene (0.67 vol. ratio), which gave a 24% weight reduction. Process and economic improvements

using less water will be investigated in future work.

Future efforts will be directed at improving economics, as assessed by TEA, and moving the process to market. Tech-to-market is certainly a critical element of moving this technology forward. The deconstruction process being developed seeks to generate polysaccharide or sugar-derived intermediate streams that have low ash. Such feeds enable diverse downstream processing options, increasing the probability that new economical routes to fuels will be developed.

BIOMASS CONVERSION TO ACRYLONITRILE MONOMER-PRECURSOR FOR PRODUCTION OF CARBON FIBERS

(WBS#: 2.3.1.200)

Project Description

Polyacrylonitrile-based, lightweight, high-strength carbon fibers are receiving great interest from THE automotive industry, particularly in their bid to improve fuel efficiency of vehicles (car weight reduced by 50% improves fuel efficiency by 35%). However, widespread application of carbon fibers is presently deterred by THE high manufacturing cost (>\$10/pound). Ninety percent of the world’s carbon fibers are polyacrylonitrile-based, derived from acrylonitrile (ACN) monomers—commercially produced from petroleum-based feedstock (e.g., propylene). Propylene prices are volatile, and its production is decreasing in the United States.

Recipient:	Southern Research Institute
Principal Investigator:	Amit Goyal
Project Dates:	1/1/2015–4/30/2018
Project Category:	Ongoing
Project Type:	FY 2013 - Carbon Fiber: DE-FOA-0000996
Total DOE Funding:	\$5,981,713

Alternative feedstocks that are available at scale, commercially viable, have a sustainable conversion process, and produce a high-purity product are desired in order to effectively reduce the cost of ACN to reach less than \$1/pound. Southern Research Institute, in cooperation with BETO, is using widely available non-food, biomass-derived sugars as raw materials at mild conditions to produce ACN (the resulting product is referred to as B2ACN). The process consists of multiple catalytic reaction steps, including hydrocracking, dehydration, and ammoxidation. In the Phase I study, several novel, high-performance catalysts were developed with an overall recoverable product yield of 35%–40% and

Weighted Project Score: 8.4

Weighting: For ongoing projects, there is equal weighting across all four evaluation criteria: Approach, Relevance, Accomplishments and Progress, and Future Work.

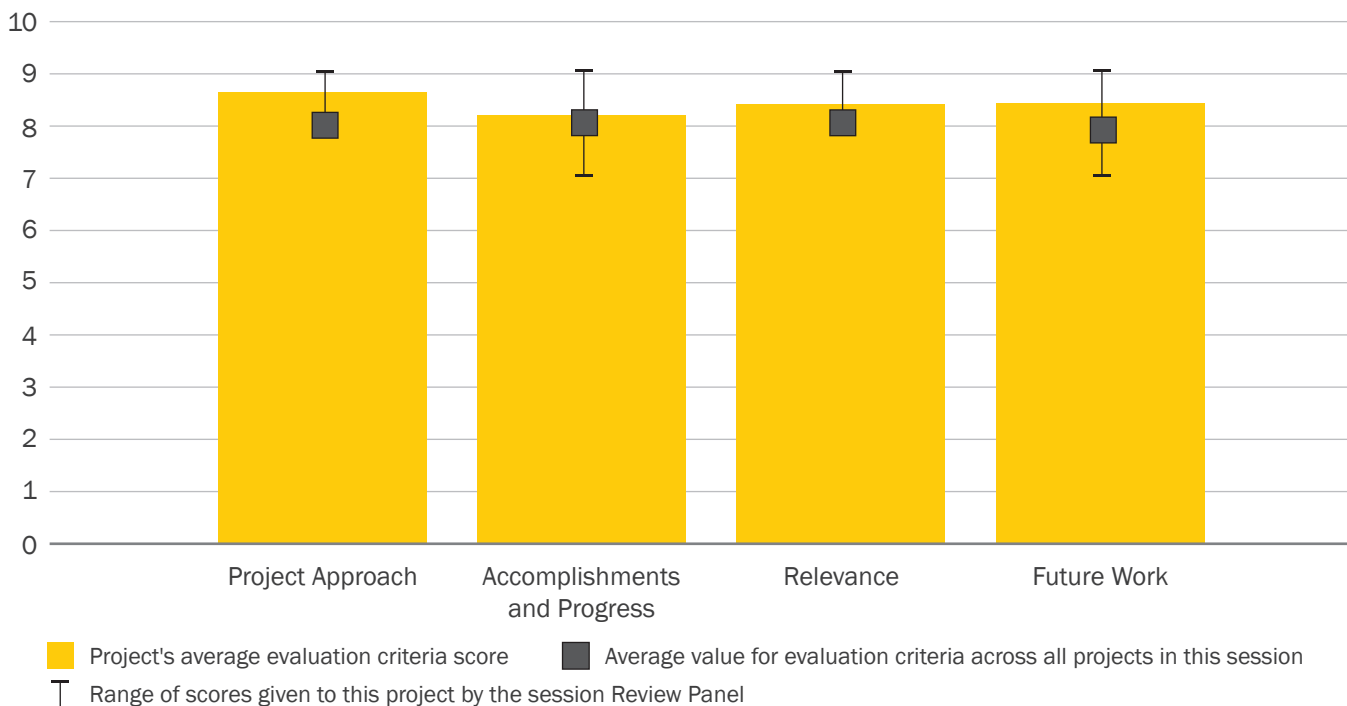

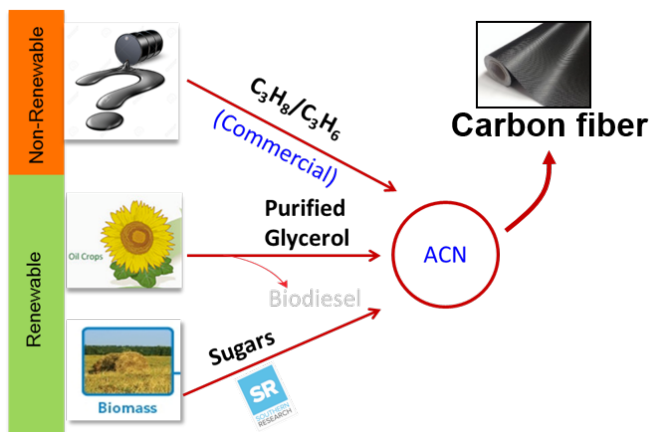

carbon recovery of 60%–80%. Based on experimental results and preliminary TEA/life-cycle analysis, we project significantly reduced cost (15%–22%) and greenhouse gas emissions (~37%) compared to conventional ACN processes.

Overall Impressions

- The project team appears to have produced a commercially attractive catalytic system to generate ACN from biomass sugars. The team looks to be poised to go forward and test out the system at larger scale and work through issues that may appear during continuous operation. Obviously, there will be a lot more work to do, but the organized approach has paid off so far, and the project looks to be on track.
- The team has developed an interesting catalytic process for the conversion of sugars to acrolein through three catalytic steps. The production costs for ACN are currently projected to meet BETO goals, but the overall process is burdened with a number of side products that will reduce industrial utility and interest. A better plan for dealing with these materials, or improvement in process selectivity, will be necessary before this process can be used for ACN production. The PIs and BETO may want to consider merging this project with the Renewable Carbon Fiber Consortium since new partnerships and collaborations may result in a suite of useful ACN approaches that might not be developed separately.

- The current ACN production from propylene is a complex and hard-to-control reaction, with a toxic byproduct. This program will provide a renewable route using a three-step catalytic process. The team has developed a novel catalyst for the first step, production of glycerol from mixed sugars, and solved some challenges around feedstock purity and a catalytic byproduct. They have achieved all metrics for Phase I, and TEA indicates favorable economics if ultimate targets are met. Critical issues that still need to be addressed are scale-up and the effect of feedstock variability. Also, it would be good to address how the economics and feasibility of this project compare to alternate approaches to renewable ACN (e.g., the biological catalytic route of the Renewable Carbon Fiber Consortium).

- This project has nicely outlined project management and metrics. The developed catalysts and process appear to be on track to meet the ACN production cost of \$1/pound. The product still needs to be tested for quality. There are interested commercial ACN manufacturers. Phase II approval is pending, but it looks promising. Note that this chemical conversion project was reviewed in the bioconversion session.
- This is a very good demonstration of dedicated team effort that is well-aligned with industrial partners to meet project goals. This is a highly skilled chemical engineering group with a can-do attitude and good collaboration for achievement mentality. The project is a good demonstration of biomass conversion potential to carbon fiber with good economical and sustainability impacts. The project team is advised to try out other lignocellulosic sugar streams that may be more advanced in their commercialization road to de-risk this end.

PI Response to Reviewer Comments

- We are very much looking forward to addressing the side streams more rigorously in Phase II. We will definitely try out more lignocellulosic sugar streams if scope and budget permit.

UPGRADING LIGNIN-CONTAINING BIOREFINERY RESIDUES FOR BIOPLASTICS

(WBS#: 2.3.1.206)

Project Description

This project uniquely addresses BETO’s mission and goals for “process development and optimization of a single-unit operation for the upgrading of chemically or biologically derived intermediates to fuels and products.” The project has the following three objectives: (1) process enablement by engineering and optimizing microorganisms to convert biorefinery waste streams to PHA for bioplastics; (2) process development by characterizing biorefinery residues, optimizing lignin treatment and fermentation, and designing the novel bioprocess; (3) process integration and optimization by conducting biorefinery onsite scale-up, as well as TEA and life-cycle analysis for the lignin-to-PHA upgrading process.

Recipient:	Texas A&M University
Principal Investigator:	Joshua Yuan
Project Dates:	7/1/2016–6/30/2019
Project Category:	New
Project Type:	FY 2013–Incubator: DE-FOA-0000974
Total DOE Funding:	\$2,499,993

The project is structured into two budget periods. The first budget period is 24 months, and the second budget period is 12 months. All three tasks will be carried out in both budget periods. The technical targets for the two budget periods are as follows. In Budget Period 1, we aim to achieve 2.4 g/L PHA titer and 30% utilization of lignin. In Budget Period 2, we aim to achieve 50% utilization of lignin and 8 g/L PHA titer. The ultimate targeted performance, therefore, is 50% lignin utilization and around 8 g/L PHA titer. Achieving the research objectives will allow us to leapfrog the technology to address an important challenge in modern biorefinery development.

Weighted Project Score: 8.0

Weighting: Approach–25%; Relevance–25%; Future Work–50%.

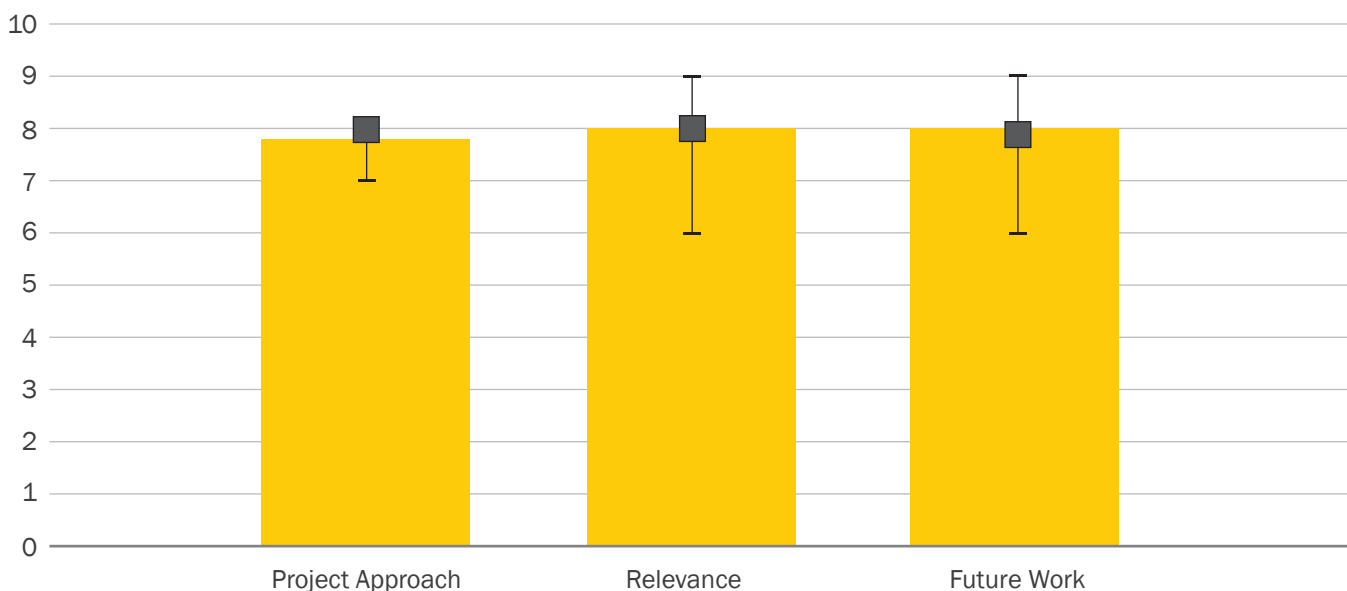

■ Project's average evaluation criteria score
 ■ Average value for evaluation criteria across all projects in this session
 Range of scores given to this project by the session Review Panel



Overall Impressions

- Overall, the presentation indicates a depth of expertise in the subject area. These are clearly areas in which the Texas A&M team is actively engaged.

As feedback, the presentation gave a very brief idea of the overall goals and structure of the effort (broken out into fairly logical steps), but then it dived right into detailed graphics that look to be taken directly from manuscripts drafts, rather than providing clear explanations of the strategies and methods that will be used on the project, significantly clouding the issue. Some idea of the timelines of activities and how tasks inter-relate would have been much more useful than such detailed figures.

Complete TEA models will be essential to finally understand whether the chemical treatments under examination here to generate lignin streams make economic sense. Pulling out the PHA portion may be useful at some point for the detailed assessment of process parameters, but understanding the effect of the process scheme, solid liquid separations, dilution of biomass material, washing steps, etc. on overall economics is central.

- The PI appears to be on an interesting path for upgrading a biorefinery waste stream through a nice combination of genetic engineering and biomass fractionation processes. Targeting PHAs as the product would seem to be a high-risk approach, given that PHAs have a long history of interest, but an equally

long history of failing as a large scale commercial product. A stronger justification of the product choice would strengthen the project.

- Lignin utilization is an essential component of the MYPP, and this project aims to convert this stream to a value-added product. The team has a good metabolic engineering approach to develop a *P. putida* strain to produce PHA from the lignin monomers, and it has some promising initial results that indicate the interim project targets set are achievable. However, PHA is a challenging market to enter, and so far, there has been limited success. There is also the technical challenge of controlling monomer chain length distribution. The uniformity of the product may also relate to market potential. Finally, it would be useful for this team to collaborate with the NREL lignin conversion work since there appears to be some redundancy.
- This project has identified good starting strains for a lignin-to-PHA development project. It is ambitious to ask a strain to depolymerize and degrade lignin, and produce PHA at a commercially relevant \$5/kg, in the toxic milieu of biorefinery hydrolysate. The project is considering pretreatment modifications to optimize both the biofuel and bioproduct yields. This presentation contained a very good use of TEA data for examining process options and setting reasonable throughput and performance goals.
- This is a good team with high energy and vast knowledge in the field. The challenges are well-understood, and the de-risking approach of all levels—from pretreatment, to strain engineering, through classical metabolic engineering and system biology approaches, to fermentation process engineering and process engineering—are well factored in. I am not sure if the TEA of PHA at \$5/kg is economically viable, but I trust the PI to follow up on this and drive the cost even to the lower \$2/kg suggested in one of the scenarios. BETO is highly encouraged to consolidate the critical parallel efforts across academic and national laboratories on similar targets (i.e., PHA ex *P. putida* from lignin) into one bigger project that will focus on several focused layers of pretreatment, strain engineering, and process development/engineering.

PI Response to Reviewer Comments

- We are engaging industrial contacts regarding both our gasoline-like main product and chemical (BTEX) co-product values and how they can be incorporated into existing refining infrastructure. Our main product still is a fuel, and the BTEX is intended as a co-product to offset operating expenses.

The ethanol producers will have the flexibility to partially or fully produce Vertimass products (gasoline-

line-like fuel and concentrated BTEX) or continue to make ethanol to take advantage of market conditions and maximize their revenue. We anticipate the ethanol RINs will transfer into our fuel product, supporting higher prices. However, the ethanol RINs do not currently transfer into the BTEX product, but these BTEX products command a price premium over fuels, so this is partially hedged.

Task	Year 1				Year 2				Year 3				Milestones
	Q1	Q2	Q3	Q4	Q1	Q2	Q3	Q4	Q1	Q2	Q3	Q4	
Project Management and Commercialization	•												Project management plan finalized
Objective 1 Process Enablement													
Subtask 1.1, Additional strain screening			•										At least one strain grows 1.5 times better on lignin
Subtask 1.2, System biology analysis				•									Provide 5 expression system, 3 for secretion
Subtask 1.3, Systems biology-guided microbial engineering to maximize PHA								•					>1 engineered strain to depolymerize >40% lignin
Subtask 1.4, Reiterative strain improvement								•					>1 engineered strain with >25% conversion rate for PH
Subtask 1.5, Develop stabilized strain for biofermentation									•				1 stabilized strain with aforementioned performance
Objective 2 Process Development													
Subtask 2.1, Lignin and pretreatment residue characterization					•								Determine 1 best type of feedstock for lignin conversion
Subtask 2.2, Pretreatment conditions and lignin reactivity						•							Determine a proper pretreatment condition
Subtask 2.3, Chemical pre-processing development											•		One process to decrease Mn by half
Subtask 2.4, Fermentation optimization									•				One process to convert 50% lignin at >25% conversion
Subtask 2.5, Bench scale process development												•	One process to convert 90% lignin at >30% conversion
Objective 3 Process Optimization and Scale-up													
Subtask 3.1, Scale up on site of biorefinery												•	One process to convert 90% lignin at >30% conversion
Subtask 3.2, TEA and LCA							•						Initial report on TEA and LCA to guide strain improvement
<p>Program-wise Go/NoGo point: At the end of year 1, we will set the Go.NoGo milestone to be 1 engineered microbial strain converting 40% of lignin; and HDO converting rest of lignin at higher than 50%. At the end of Year 2, the Go/No Go Milestone will be 150g/L butanol with a 20% conversion efficiency for lignin to butanol using biological route and over 70% HDO lignin efficiency.</p>													

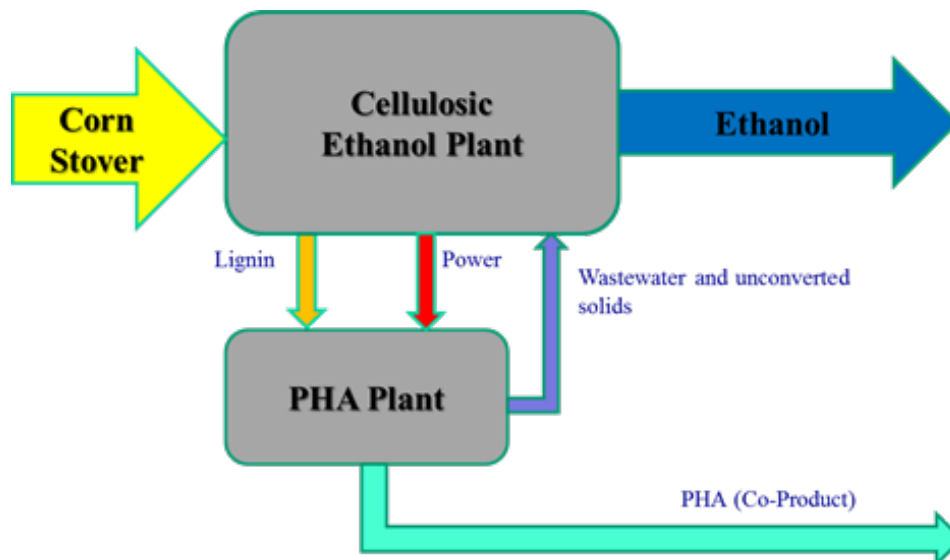

Block diagram illustrating the relationship between an existing cellulosic ethanol plant and a bolt-on PHA production plant proposed by this project

Third, regarding PHA as a product, the bioplastics market is increasing exponentially. According to some estimates, by the end of the project at 2019, global bioplastics production will reach 7.8 million tons. PHA is one of the major bioplastics with biodegradable capacity and also has a significantly increasing market. In spite of the failed joint venture between Metabolix and ADM, the global PHA production capacity is actually increasing, primarily in Asia. Many factors contributed to the Metabolix exit. The proposed approach clearly has two major advantages. On one side, the feedstock is the low-cost biorefinery waste. On the other side, the process integrates with the lignocellulosic biorefinery, which will reduce the overall capital expenditure and operation cost for the bioplastics units. The multi-stream integrated biorefinery will allow us to further reduce the cost for bioplastics production, as indicated in the TEA analysis.

Fourth, regarding the economic competitiveness of PHA at \$5, the price of PHAs produced by current manufacturers is estimated at \$1.66–45.54/kg, while the minimum PHA selling price calculated in this initial TEA is \$2.84/kg with the proposed strategy. The technology is therefore competitive with current platforms.

Fifth, regarding engineering multiple activities within the same strain, we appreciate and agree with the reviewer that strain engineering alone may not achieve the technical and economic targets of the project. This is why we have included fractionation and pretreatment optimization, along with fermentation improvement, to mitigate risks. The choice of the strain and the bioprocess configuration will eventually depend on the integration of these different layers of technologies, as guided by TEA and technology performance.

Sixth, regarding the collaboration with other NREL projects for lignin conversion, we have already discussed the synergy and collaboration with the relevant PIs. Importantly, based on our discussion and project review, the efforts between different lignin utilization projects are very complementary to one another, and there is no significant redundancy. These multiple projects enable the development a complementary and complete portfolio of technologies for multi-stream integrated biorefineries. It will also help to de-risk the technology development and improve the productivity and accountability.

The figure below shows a breakdown of the relative cost contributions to the minimum PHA selling price. Material costs represent the largest cost contribution and are primarily driven by solvent costs for PHA extraction and purification. Thus, project work around optimization of solvent selection, recovery, and recycling represents a major opportunity for reducing the minimum PHA selling price and improving the techno-economics of the project.

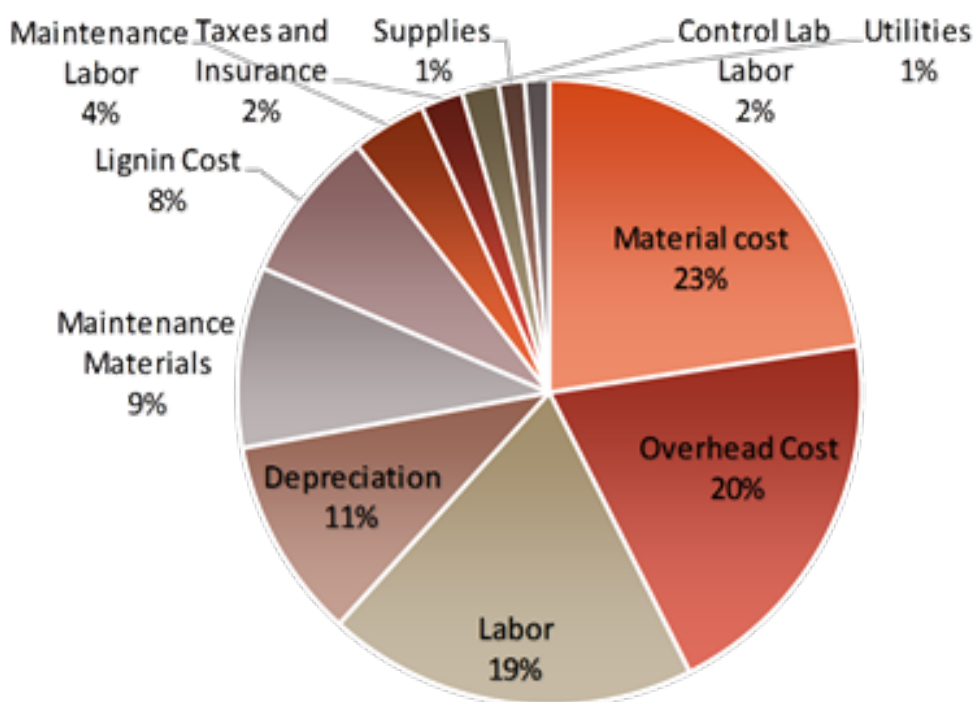

Cost contributions to minimum PHA selling price

BIOLOGICAL LIGNIN DEPOLYMERIZATION

(WBS#: 2.3.2.100)

Project Description

The joint Biological Lignin Depolymerization project between NREL and Sandia National Laboratories aims to develop biological solutions for the depolymerization of lignin polymers and oligomers. Overall, this project will contribute to lignin valorization efforts in the biorefinery, which are essential for cost-effective hydrocarbon fuel production. Specifically, this project has examined potential approaches to depolymerize both (1) solid residual lignin resulting from process-relevant, BETO-funded polysaccharide deconstruction approaches, such as the Deacetylation, Mechanical Refining, and Enzymatic Hydrolysis project, and (2) solubilized lignin from process-relevant catalytic treatments of lignin, streams that both contain polymeric and oligomeric lignin.

Recipient:	National Renewable Energy Laboratory
Principal Investigator:	Gregg Beckham
Project Dates:	10/1/2015–9/30/2018
Project Category:	Ongoing
Project Type:	AOP
DOE Funding FY 2014:	\$125,000
DOE Funding FY 2015:	\$500,000
DOE Funding FY 2016:	\$600,000
DOE Funding FY 2017:	\$550,000

The Biological Lignin Depolymerization project has identified effective basidiomycetes for producing lac-case- and peroxidase-rich cocktails and has combined these cocktails with microbes to demonstrate higher extents of lignin depolymerization via a “microbial sink” for catabolism of the low-molecular-weight aromatic species. Moreover, we have demonstrated the conversion of solubilized lignins by multiple aromatic-catabolic microbes using native enzymatic machinery. Going forward, this project will focus on elucidating the full enzyme suites employed by microbes for breaking down

Weighted Project Score: 6.9

Weighting: For ongoing projects, there is equal weighting across all four evaluation criteria: Approach, Relevance, Accomplishments and Progress, and Future Work.

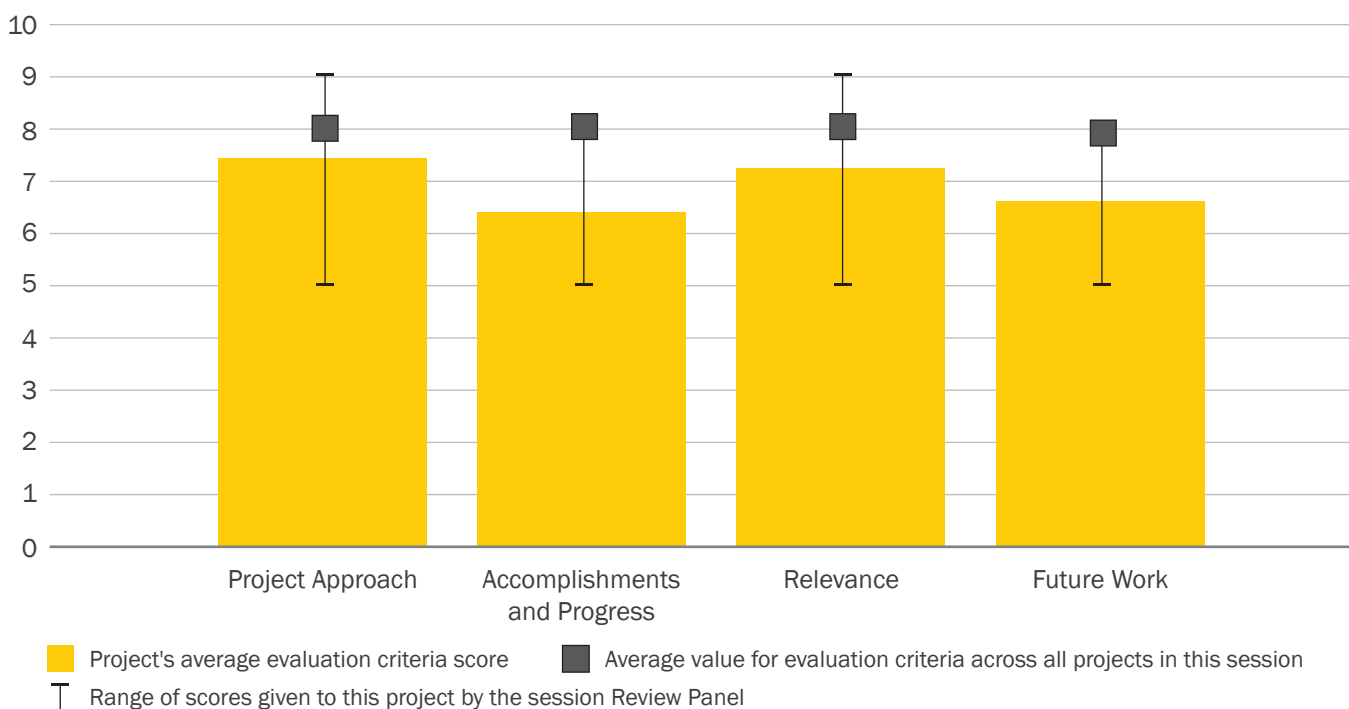

Biorefinery Lignin



solubilized lignin polymers—to make lignin oligomers more readily available for aromatic-catabolic microbes that are being engineered to produce co-products in other BETO projects.

Overall Impressions

- The idea of a microbial sink to drive forward lignin degradation by pulling in low-molecular-weight compounds was a good one. This could have presented the opportunity to make a thorough survey of ligninases in the presence of a production organism. Given the source of many ligninase sequences in the public domain, heterologous expression in a fungal host, like *T. reesei*, would have perhaps allowed a more comprehensive survey.

The project has identified issues and developed improved techniques, but it doesn't feel like the CBP idea of expressing ligninases in a Gram-negative host is great direction to go in. Certainly, there are multiple options for mixing chemical catalysis and depolymerization conditions with biological solutions, but I think these would be more complete with a more robust approach to enzyme diversity.

- The project presents a novel idea of combining fungal enzymes with microbial systems to realize both lignin deconstruction and simultaneous inhibition of repolymerization. However, the current process runs

the risk of becoming overly complex, as additional treatments of lignin are necessary for its solubilization, while a large amount of organism development still appears to be necessary. Further, a better understanding of the lignin composition and the amounts actually converted will strengthen the project. The project would benefit from settling on one or two routes for deeper examination and optimization.

- This program takes an alternate approach to lignin depolymerization, which the team has shown to be extremely challenging. After challenges getting enzymes to robustly solubilize lignin, the team decided to refocus on using chemical solubilization followed by microbial depolymerization of the soluble lignin. This was a good strategic decision, and it makes the project more viable and synergistic with other work.
- There were many encouraging reviews in previous years. Utilizing the lignin cake has high industrial relevance. The concept of biological depolymerization for lignin conversion—and even as a cleanup for chemical oxidative depolymerization—still has a very long way to go. The enhanced understanding of lignin structure and bonds that this and related lignin projects contribute is valuable. Linking this knowledge to key enzymes with the specificity to break those bonds is also valuable. Producing a CBP organism that can depolymerize/solubilize/monomerize lignin and “bio-funnel” the myriad aromatics to a product like muconic acid would be a home run, if it were possible. It's a really long stretch goal because the proof-of-concept hasn't worked, and maybe this is not the best use of these talented resources.
- The project is very relevant to BETO goals, the management plan is sound, and the technical plan (given the challenges of this topic) is reasonable. The starting from scratch approach, given the poor reproducibility of existing knowledge from prior academic laboratory work, puts and additional hurdle

before the project team. This is very low-budgeted project for the task at hand, and it is impressive to see how much work to de-convolute challenges and identify opportunities was carried. Capitalizing on the Environmental Molecular Sciences Laboratory at PNNL and the experts at the Biological Research Center of the Spanish National Research Council is highly encouraged for prospecting of good candidates. It might be useful to partner with enzyme providers to identify good starting points to enzymes expressed by *P. putida*, as the CBP approach, while it has potential and value in some aspects, is still not technologically ready. The project team and BETO should evaluate this project in the bigger project context of lignin de-polymerization and conversion to products.

PI Response to Reviewer Comments

- We thank the reviewers overall for the constructive feedback and comments. Expression of heterologous enzymes in filamentous fungi is one route to produce ligninolytic enzymes, but this would require a very significant amount of time and resources, which we do not currently have bandwidth for in this project. This is an interesting approach, perhaps meriting its own AOP. In addition, this approach has been tried extensively in the peer-reviewed literature with known enzymes, and it has not yielded tangible results for the depolymerization of insoluble lignin, to our knowledge. More work on discovering novel lignolytic enzymes (primarily nucleophilic enzymes) that cleave specific lignin linkages is needed. As such, we are shifting focus to identify and engineer nucleophilic enzymes that are able to cleave dimers and small oligomers that result from chemical catalysis.

We also completely agree with the reviewer that secretion of oxidoreductases will be challenging; as such, we have stopped work on expressing oxidoreductases to be secreted in bacteria and are focused solely on nucleophilic enzymes that are able to break down dimers and oligomers.

In terms of process complexity, we stress that this project going forward will be solely focused on identifying and engineering enzymes that are able to cleave dimers and oligomers in tandem with detailed lignin analytics, directly in line with the reviewer feedback. We are also focusing on the catalytic streams being produced in the Lignin Utilization project and by industrial conversion processes.

Regarding the CBP concept, this was simply a proof-of-concept study. In this study, we identified that many aromatic-catabolic microbes are able to depolymerize oligomers. This finding in itself is valuable, when taken with the analytical and proteomics work that is ongoing, to understand what linkages in oligomers are being broken by which enzymes and—just as importantly—what linkages are not being broken. This will enable us to understand the interplay between chemical catalysis (what linkages remain in dimers and oligomers) and the microbial engineering going forward.

In terms of the larger lignin portfolio and the collaborative efforts, we thank the reviewer for the positive comments. We also note that this project closely collaborates with the Lignin Utilization and Targeted Microbial Development projects, and indeed, in many cases, the same staff members are working between these projects. The Biological Lignin Depolymerization project keeps the “big picture” in mind throughout the development of biological lignin depolymerization strategies.

FUNGAL GENOMICS— GENETICS (FORMERLY: FUNGAL GENOMICS)

(WBS#: 2.3.2.103)

Project Description

In the Fungal Genomics project, we focus on the development of non-traditional but industrially relevant fungal platforms with desirable attributes for producing advanced biofuels and bioproducts or their precursors at a scale that can be translated to industrial processes. Desirable attributes include the ability to utilize a wide variety of sugars from lignocellulose, robustness with regards to growth in the presence of inhibitors from biomass pretreatment, and the ability to produce a variety of compounds at TRY that drive toward techno-economic feasibility.

We utilize a parallel approach of manipulating the organism through genetic engineering and bioprocess engineering to develop and optimize the overall

Recipient:	Pacific Northwest National Laboratory
Principal Investigator:	Jon Magnuson
Project Dates:	10/1/2015–9/30/2018
Project Category:	Ongoing
Project Type:	AOP
DOE Funding FY 2014:	\$0
DOE Funding FY 2015:	\$1,650,000
DOE Funding FY 2016:	\$1,650,000
DOE Funding FY 2017:	\$1,500,000

bioprocess. With regards to TRY in oleaginous yeast *Lipomyces*, we have achieved 95% of theoretical yields of paraffinic biofuel precursors in the form of triacylglycerides at up to 56 g/L titers at 1 g/L/hour. The challenge is to approach all of these high values at once using impure sugars. We have genetically engineered *Aspergillus* to produce two polyketides at more than 0.5 g/L and terpenes at tens of mg/L. This workhorse fungus provides a platform for a variety of biofuels/bioproducts precursors to add value to the biorefinery and to help lower the selling price of the biofuel.

Weighted Project Score: 7.1

Weighting: For ongoing projects, there is equal weighting across all four evaluation criteria: Approach, Relevance, Accomplishments and Progress, and Future Work.

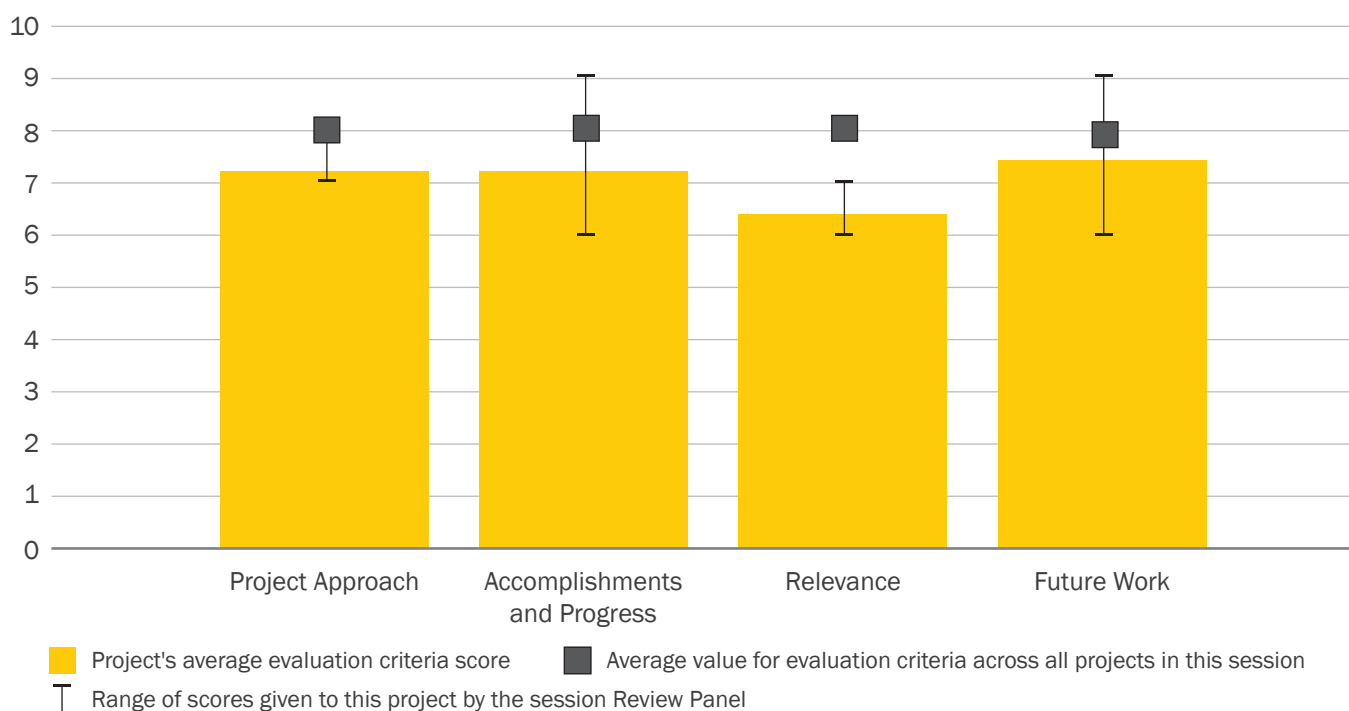

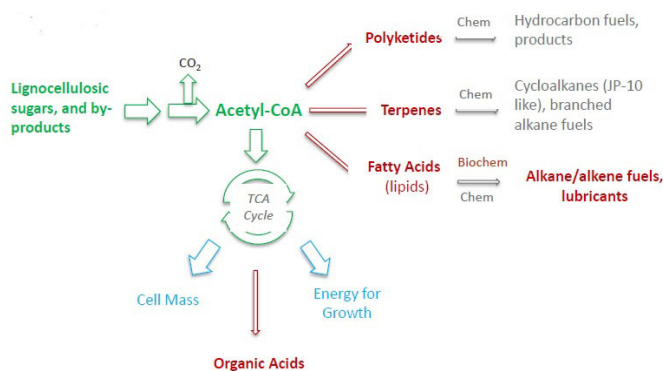

Overall Impressions

- The project offers potential to expand the suite of organisms available to industry as platform hosts, with advantages in process tolerance and developed genetic tools.

The execution of the project and prioritization of tasks probably needs some attention. In a few areas, it feels like a more systematic approach would help out, and perhaps direct collaboration with outside groups (mostly here I'm thinking about the results from the NREL team on predicting mutations for metabolic engineering).

- While the overall concept is solid and uses a well-established procedure for choosing and engineering organisms for bioproduction of chemicals and fuels, the specific experimental work has been less successful. By focusing on a highly reactive chemical (octatrienoic acid [OTA]) as a product, the PIs have chosen a material that may be difficult to isolate and test as an intermediate for other materials. It is likely that OTA is not the best choice in this program and that production of other materials may benefit the experimental effort.
- The Fungal Genomics project aims to exploit the unique capabilities of fungal organisms for bioconversion. Non-Saccharomyces fungal species have traditionally been used in a variety of fermentation processes, from antibiotics to citric acid. Oleaginous yeast represents an opportunity for free fatty acid production, and the team has identified a species

that may be more suitable than *Yarrowia* and put in a lot of effort to develop good genetic tools. As oleaginous yeast is a major focus of NREL projects, there should be more collaboration between NREL and PNNL to ensure work is not redundant. *Aspergillus* is also a good host with already established tools, but the titers obtained for the target product (OTA) are still very low. It will be challenging to get increases of two to three orders of magnitude because polyketide synthases are hard to manipulate. In addition, the compound will likely be very reactive, both in vivo and in subsequent processing. The 3-hydroxypropionate work may be more fruitful in the short term.

- The team is making good progress in developing genetic tools to facilitate development of *Lipomyces* for lipid production. Development of new, robust, industrially relevant bioproduct and biofuel production hosts has the potential to accelerate new product introductions.
- The team shows good progress in developing molecular tools and understanding of the challenges. There is great collaboration with the SCADA team to enable process development with a real-time, data-driven approach. The current focus on *Lipomyces* is the right choice, although the economics are questionable overall (not in the project team's hands) and need better guidance based on rigorous TEA analysis. A slide with metrics of progress toward goals, including metrics of TEA in regards to the technical accomplishments, would be nice and should be applied across all projects. I recommend you have a joint umbrella with a critical mass of expertise to gain momentum and focus all the fungal development projects for enzymes and fuels on the biggest gain for the buck approach.

PI Response to Reviewer Comments

- We thank the Review Panel for their positive comments and helpful critiques. We appreciate the gen-

erally positive comments about the significance of the development of genetic tools in *Lipomyces starkeyi* and its promising potential as a lipid producer for biofuels applications. We are working on selecting an even more robust biomass hydrolysate-utilizing strain through use of a turbidostat, and we appreciate the emphasis the Panel placed on this research thrust. In addition, we will soon obtain less-inhibitory hydrolysates available from new industrial partners, which we will test in the near future to maximize the chance of increasing TRY in *Lipomyces*.

The collaboration with the NREL team (regarding *Lipomyces*) is active but could use additional emphasis and communication. We initiated the transfer of additional materials and knowledge between the laboratories at the 2017 Project Peer Review meeting in March and plan to visit one another in the near future.

The comments and concerns regarding the relatively low OTA titers obtained in *Aspergillus* to date (concerns that included meeting our March 31 milestone), degradation issues, and utility as a biofuel or bioproduct intermediate are well-taken. Since the Project Peer Review meeting, we have exceeded our March 31, 2017, go/no-go target of 1 g/L in shake flask studies—where, in contrast to the bioreactors, the degradation issue is not observed. Thus, we have demonstrated a greater than 50% improvement over titers reported at the Project Peer Review meeting.

We have hypotheses regarding prevention of degradation of OTA in the bioreactor environment, based on prior evidence in our laboratory or precedence in the literature, which we will test in the near future. These include restricting oxygen late in the culture and increasing nitrogen concentration to prevent expression of accessory enzyme in the OTA biosynthetic cluster from modifying OTA to another chemical compound. Regarding the utility of OTA as an intermediate for biofuels or bioproducts, since the Project Peer Review meeting, we have demonstrated that it hydrogenates readily. We are now very excited about ketonization to dimerize the resulting octanoic acid for a biofuel precursor, as well as another process using the monomer that could lead to an extremely useful bioproduct in two well-understood catalytic steps.

We are certainly open to alternative target selections, but with the encouraging results on OTA since the Project Peer Review—meeting our milestone and promising developments on the catalytic conversion front—we are planning to push hard on this molecule through the remainder of FY 2017 towards the very ambitious year-end 2.5 g/L milestone; we will then revisit this target selection, in cooperation with our BETO technology manager and our industrial advisory panel, before proceeding with work on OTA or an alternative target in FY 2018.

SYNTHETIC METABOLIC PATHWAYS FOR BIOCONVERSION OF LIGNIN DERIVATIVES TO BIOFUELS

(WBS#: 2.3.2.104)

Project Description

A vital component to meeting domestic sustainability and energy independence goals in the United States is the economic production of liquid transportation fuels and chemical building blocks from lignocellulosic biomass in a biorefinery. While the majority of biofuels research has focused on the conversion of sugars into fuels and products, adding value to the lignin fraction of biomass (for instance, by bioconversion to high-value products) is essential to meeting BETO's 2022 goal of \$3/gge. Therefore, the goal of this project is to develop biological routes to convert lignin-derived aromatic compounds into value-added fuels and chemicals. To this end, we are engineering *Pseudomonas putida*

Recipient:	Oak Ridge National Laboratory
Principal Investigator:	Adam Guss
Project Dates:	10/1/2015–9/30/2018
Project Category:	Ongoing
Project Type:	AOP
DOE Funding FY 2014:	\$230,000
DOE Funding FY 2015:	\$350,000
DOE Funding FY 2016:	\$350,000
DOE Funding FY 2017:	\$350,000

to accomplish the following objectives: (1) increase conversion of aromatic compounds derived from lignin to medium-chain-length PHAs, and (2) produce medium-chain-length alcohols (e.g., C8–C12 alcohols) and other molecules.

Engineered strains of *P. putida* had a 100% increase in PHA abundance per dry cell weight and a PHA titer increase of 200% during growth on depolymerized lignin. For alcohol production, we used a new DNA integration system to test 20 initial pathway designs, which allowed

Weighted Project Score: 7.8

Weighting: For ongoing projects, there is equal weighting across all four evaluation criteria: Approach, Relevance, Accomplishments and Progress, and Future Work.

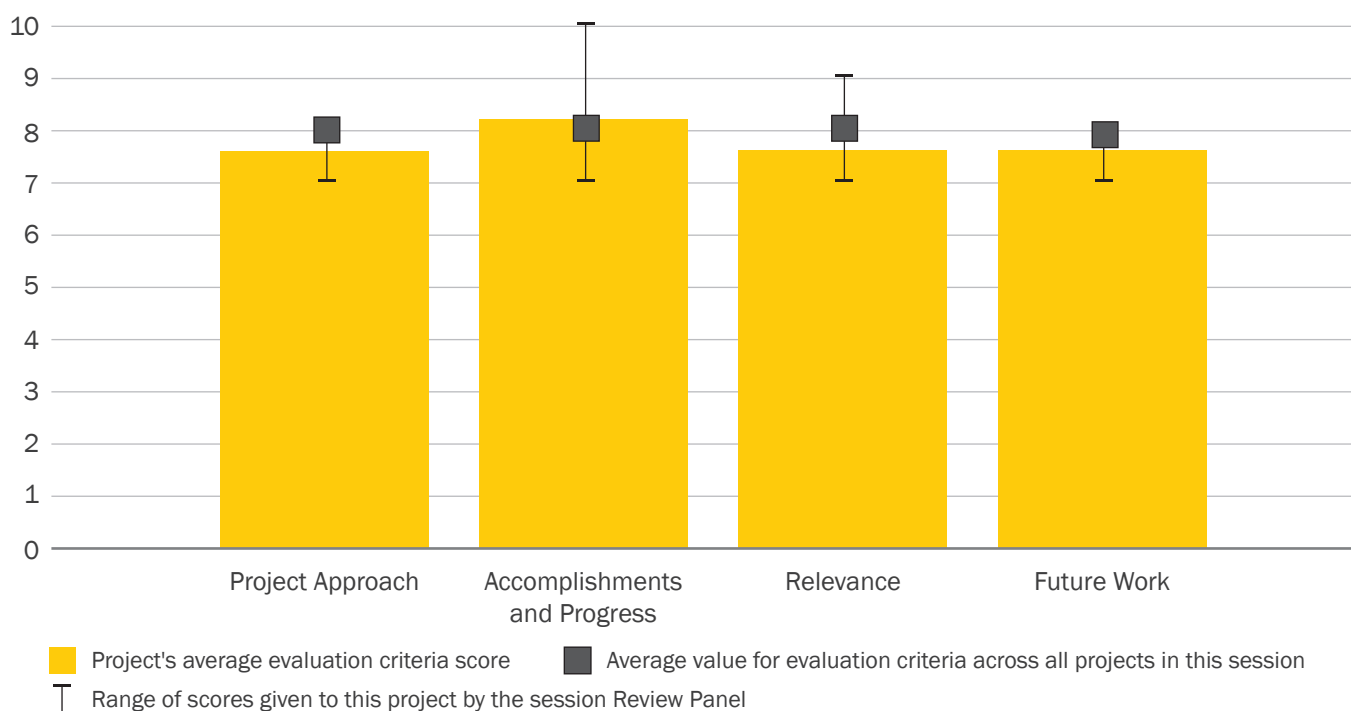

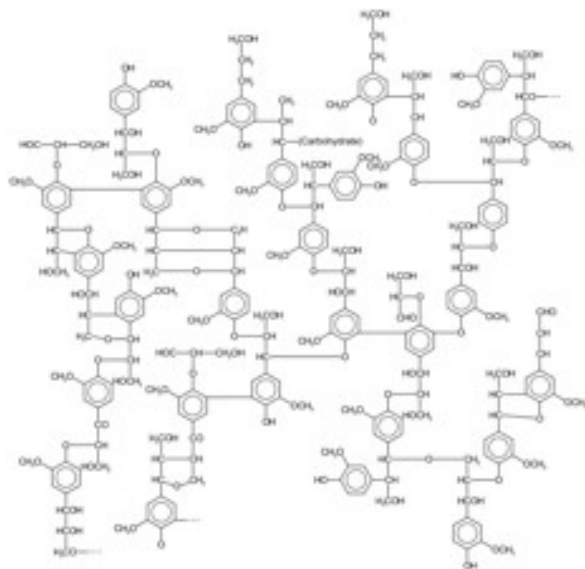

for conversion of coumaric acid to approximately 12 mg/L decanol and dodecanol. Further strain design and pathway optimization is expected to dramatically improve alcohol yield and titer, providing proof of concept for lignin valorization toward enabling a bioeconomy.

Overall Impressions

- Although the funding level for the Oak Ridge National Laboratory project looks lower compared to the efforts at NREL, it looks like a very valuable addition to the technology package. In particular, the phage integrase system for integrating multi-gene cassettes at a single site at high efficiency looks like a great tool to enable higher-throughput synthetic biology strategies. In a short slide deck, it isn't possible to cover every aspect, but it would have been good to see how the team will make full use of the technique (e.g., whether Oak Ridge has the automation capability, or whether the team will tap into the Agile BioFoundry effort).

The medium-chain-length alcohols look like a good target for an output molecule. Getting an early read on the toxicity of these products to the *P. putida* system would be a good idea, to make sure there isn't another large technical challenge out there that will limit progress towards economic levels of

production, in addition to the metabolic engineering required for use of lignin derivatives.

Delivering the TEA will be a key step in identifying performance targets for the team.

- Efforts to increase the potential portfolio of lignin products are a strength and will expand opportunities for industry to scale up lignin conversion processes. It is unclear whether the medium chain alcohols are reasonable targets as their markets will be much more fragmented than adipic acid. The PIs should work to better define the reasonable market share that could be realized with medium-chain alcohols and determine whether their materials would be produced at a high enough volume to affect the BETO 2022 milestone.
- This project aims to convert lignin depolymerization streams to PHA or medium-chain alcohols. The need for lignin valorization to enable BETO to reach the economic targets in the MYPP is well-established, and it is important enough that various approaches to utilizing lignin monomers should be considered. However, titers and yields for this program are much lower than that for conversion to adipic acid. Also, the metabolic pathways are much longer due to the need for integration into central metabolism (acetyl-CoA) rather than a direct bio-conversion pathway to muconate. This program has shown some promising results, and thus should be continued for now, but eventually a decision has to be made to focus *P. putida* efforts to a single product. Thus, the program manager and PI should keep this in mind, especially when considering continuing the effort beyond the end of this project period.
- The project is making progress producing PHA and medium-chain-length alcohols in *P. putida*. The project is cognizant of the current selling price for medium-chain-length alcohol, and comparison to the adipic acid base case. They are currently conducting a TEA (FY 2017 milestone), which should

provide a useful reality check on the significance of the titer milestones. Development of a high-throughput, screen-amenable, site-specific recombination system for transforming *P. putida* as efficiently as a replicating plasmid is a nice accomplishment that can be leveraged.

- The project team developed an array of metabolic engineering tools and an understanding of how to work with *P. putida* that will likely accelerate other future programs in this direction.

PI Response to Reviewer Comments

- We would like to thank the reviewers for their insightful comments and questions.

The phage integrase system is simple enough that automation is not required for a throughput in the range of dozens to a few hundred pathway variants, and the bottleneck then often becomes strain characterization. While automation would make strain construction less tedious, automation and/or high-throughput methods will be even more critical for strain characterization. For much higher throughputs, a robust screen (e.g., fluorescence-activated cell sorting) or selection will be critical for rapid strain improvement. To enable higher-throughput methodologies, we and our collaborators are working to adapt the CRISPR-based method “CREATE” in *P. putida*, which, for instance, could be combined with the integrase system to screen or select protein or pathway variants that have improved performance.

Regarding product toxicity, we have already evaluated toxicity of some medium-chain alcohols, and *P. putida* is tolerant to at least 1% volume/volume (~8 g/L) octanol and decanol, which is well beyond the solubility limit for these compounds. Determining the tolerance to additional alcohols and mixtures of alcohols will be important going forward.

We agree that TEA is critical as a point of reference to evaluate strain performance, identify target metrics, and model economic feasibility. We have completed the initial TEAs for each of these routes, and there are promising strategies to help meet the \$3/gge BETO goal. Work is ongoing between the R&D team and the TEA team to outline specific process metrics and R&D strategies to meet yield targets and address any outstanding data gaps, with a plan to re-examine this TEA with this additional data by the end of FY 2018.

We agree about the need to demonstrate substantial progress in producing an exemplar molecule. Mucionate has high carbon efficiency from aromatics, making it a promising target, but it is challenging to make from other substrates. Molecules like medium-chain-length alcohols, on the other hand, are derived from central carbon metabolism and can be generated from more than just aromatics, including acetate and hemicellulose-derived breakdown products that are often present in lignin streams. Therefore, we feel there is value in having a portfolio of products that can be made from lignin, including ones derived from central metabolic intermediates, such as medium-chain-length alcohols.

This project allows BETO to diversify the product slates for upgrading waste carbon, including from lignin or carbon lost from other sources, like acetate or hemicellulose derivatives. Expanding the range of potential products and markets available from these waste carbon streams will further ensure that one product will not completely saturate a market. We plan to use a combination of TEA and discussion with BETO technology managers to strike the best balance between progress on exemplar molecules and product diversity.

BIOLOGICAL UPGRADING OF SUGARS

(WBS#: 2.3.2.105)

Project Description

The Biological Upgrading of Sugars project develops robust microbial strains to produce fuel precursors at the required TRY for the BETO 2022 hydrocarbon fuel target of \$3/gge. From FY 2015–FY 2017, the Biological Upgrading of Sugars project has conducted a large screen of oleaginous yeast strains to produce fatty acid–derived products, resulting in the down-selection of a particular yeast strain (*Rhodosporidium toruloides* 4444) for producing diesel precursors. This strain has been engineered to produce secreted fatty acid–derived products. Moreover, we have screened a yeast genome knockout collection to identify genes that render yeast more susceptible for cell lysis—one of the most expensive steps in intracellular fatty acid recovery.

Recipient:	National Renewable Energy Laboratory
Principal Investigator:	Gregg Beckham
Project Dates:	10/1/2014–9/30/2017
Project Category:	Ongoing
Project Type:	AOP
DOE Funding FY 2014:	\$0
DOE Funding FY 2015:	\$1,800,000
DOE Funding FY 2016:	\$1,800,000
DOE Funding FY 2017:	\$1,800,000

Moving forward, the Biological Upgrading of Sugars project has shifted focus to anaerobic secreted products, namely short-chain carboxylic acids, given the significantly lower production costs, the ability to reach larger scale than aerobic processing, and the ability to convert these acids to jet and diesel fuels. We are currently evaluating both a bacterial (*Clostridia butyricum*) and a low-pH yeast platform for an eventual down-selection towards a 2022 pilot-scale demonstration. By providing strains to integration efforts, this project is directly relevant to meeting BETO cost target goals, and we closely

Weighted Project Score: 8.4

Weighting: For ongoing projects, there is equal weighting across all four evaluation criteria: Approach, Relevance, Accomplishments and Progress, and Future Work.

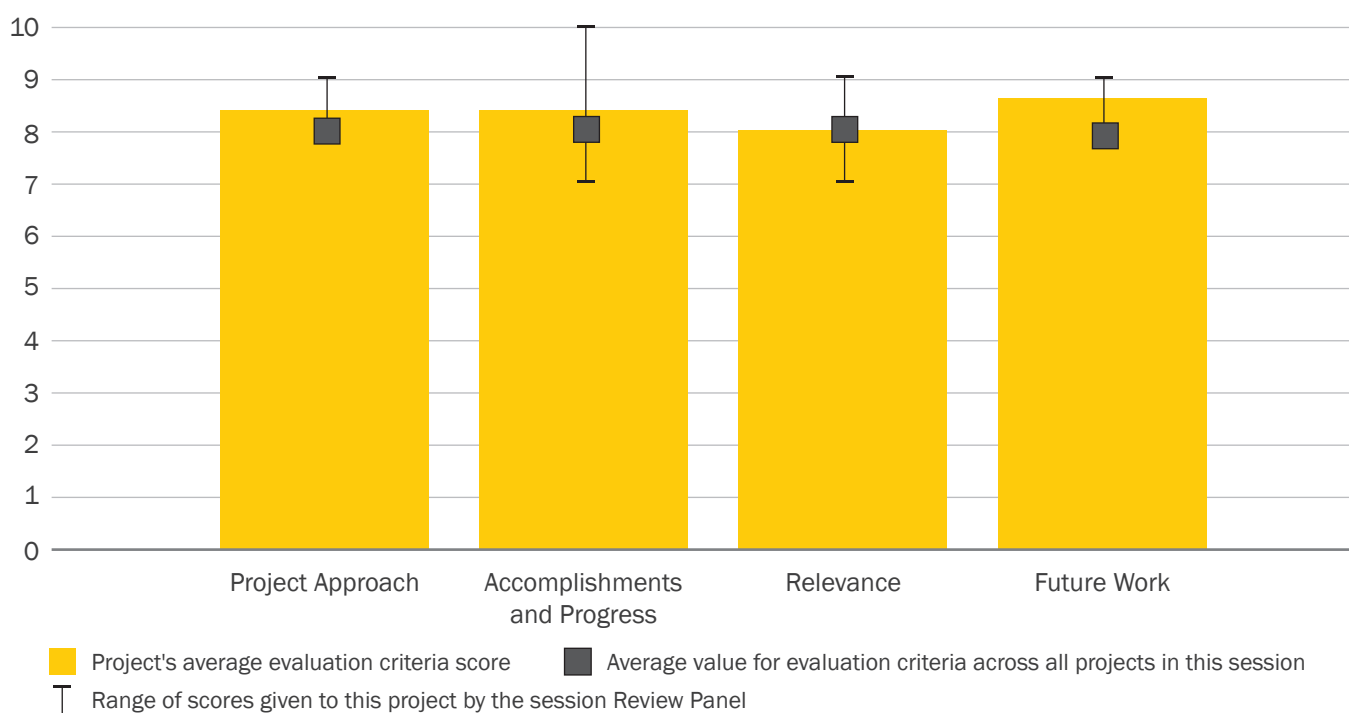

C. tyrobutyricum***C. butyricum***

collaborate with other BETO projects on co-designing strains within the context of a fully integrated conversion process to produce renewable hydrocarbon fuels.

Overall Impressions

- Overall, the project looks well-run and has been positioned properly to take a fresh look at host strain selection for economic production of advantageous products from the sugar streams generated in the NREL process. What comes through strongly is that the team has taken a logical, coherent approach, with the addition of some areas of innovation (yeast strain lysis sensitivity and continuous extraction). The project looks to be well-connected to other NREL projects and has formed connections to industrial partners for key technology areas.

A useful output may be a more detailed report of the strains and technologies surveyed than may perhaps be considered for a peer-reviewed publication. The utility here is to save companies from covering the same ground, and so a detailed report of the options explored would be very useful.

- The targets for biological upgrading of sugars are reasonable approaches for producing hydrocarbon fuels from biomass and offer routes that fit within current BETO TEAs. Good progress has been made on both of the research aims of the program (biolog-

ical lipid and acid production), and the future work has identified the key challenges that should be addressed. The project overview would be strengthened by more detail regarding the catalytic upgrading of short-chain acids to fuel-length hydrocarbons, both in a technical and economic context.

- The Biological Upgrading of Sugars project is a critical piece of the biorefinery, responsible for the conversion of sugars to fuels and co-products. The team is developing two product/host combinations to mitigate risk and is even looking into different possibilities within each aim. Excellent progress has been made toward the targets, and it seems likely that all will be reached by the end of the project. However, some of the most challenging aspects of strain and process development still remain (possibly before or after the interim targets), after all the more obvious and straightforward strain improvements have been done. Future plans include the use of omics and coordination with the bench-scale integration group, which could help elucidate the more non-obvious routes to improvement.
- The Biological Upgrading of Sugars project has taken several routes to sugar upgrading to make fuel precursors. They have done a nice job of making down-selections to accomplish the following objectives: (1) deliver an oleaginous yeast strain to an integration team for longer-term process development, and (2) turn their strain engineering attention to C₂–C₄ produced in anaerobic fermentation. Yeast and bacterial candidates are still being considered for C₂–C₄ production, and that down-selection is the future focus. The presentation was well-organized, and decision points were clearly explained. Add SMART (specific, measurable, achievable, relevant, timely) goals.
- The project objectives are well-aligned with BETO's objectives of finding molecules (other than ethanol, diesel, and jet fuels precursor molecules) to meet the \$3/gge equivalent. The choice of strains,

molecular tools development, and testing strategies are sound. The management approach is well-structured, and the team has established much good collaboration to accelerate this R&D effort. The PI, together with the TEA team, needs to evaluate the production cost of C16–18 fatty alcohols as fuel. I doubt if hydrolysate feed of C6/5 stream will cut it compared to alternatives in the market (i.e., plant oil and petro-derived long-chain alcohols). The PI already recognized this, and future work takes this into account. Another recommendation will be to try to find know-how (which exists) in industry in the United States as way to accelerate this R&D effort. As for the short-chain carboxylate program, a good risk-mitigation strategy was taken with evaluating both *Clostridia* and acid tolerance yeast. It would have been useful, and it's possible, to direct choice of routes based on thorough TEA, which appears to be the team's direction.

PI Response to Reviewer Comments

- Overall, we thank the Review Panel for the positive comments and constructive feedback to improve the quality and output of the Biological Upgrading of

Sugars project. We agree that a detailed report on the history of the project would be a useful output for industrial entities, and we will make this a target of the project output going forward.

In addition, we apologize for omitting details on the catalytic upgrading routes due to time constraints (this work was presented in detail in the Thermochemical Conversion session), but the catalytic work is being done in very close concert with the biological and separations components to ensure success in process integration. Briefly, we are approaching near-theoretical acid coupling yields to generate mixed ketones from C2/C4 and C4/C6 mixed acids during continuous processing with stable catalyst performance for over 24 hours. Near quantitative yields were also achieved when converting methyl ketones to branched cyclic compounds via condensation pathways. Lastly, quantitative hydrodeoxygenation of mixed ketones was demonstrated with over 24 hours of catalyst stability. Further work is ongoing to evaluate these upgrading routes with biologically derived mixed acid streams.

Lastly, we also note that SMART goals are a core component of our management strategy, even though these were not listed explicitly in the presentation.

CONTINUOUS MEMBRANE-ASSISTED IBE FERMENTATION FROM AVAP CELLULOSIC SUGARS

(WBS#: 2.3.2.202)

Project Description

This project utilizes diverse lignocellulosic sugars from pine, stover, and straw using the American Value-Added Pulping (AVAP) process in Thomaston, Georgia. We produce isopropanol, n-butanol, and ethanol (IBE) by fermenting genetically modified *Clostridia Acetobutylicum*, AVAPClo. Fermentation using continuous membrane-assisted fermenters targets productivity of 12 g/L/hour over 0.5 g/L/hour in batch and cuts capital costs in half. We also use solvent recovery using non-toxic liquid/liquid extraction in place of stripping targets to reduce thermal energy in half. Water, unused sugars, nutrients and intermediates are efficiently recycled.

Recipient:	American Process Inc.
Principal Investigator:	Dr. Vesa Pykkänen
Project Dates:	7/1/2015–11/30/2017
Project Category:	Ongoing
Project Type:	FY 2014—Biological and Chemical Upgrading: DE-FOA-0001085
Total DOE Funding:	\$3,088,632

The project has successfully completed the intermediate validation stage. The integrated run was performed at average 10 g/L/hour productivity using pine C5 and C6 feedstocks. The second budget period focuses on optimizing process parameters in a 500-hour run. We will apply value engineering and process integration to reach an IBE production cost of \$2/gallon from the benchmark \$3.20/gallon and to determine lifetime greenhouse gas emissions. Proper R&D scale-up will be followed by potential commercialization efforts. The expected outcome is a robust process to broaden feedstocks and intensify sugar-based upgrading to higher alcohols at below the DOE target MFSP of \$3/gge. IBE alcohols

Weighted Project Score: 8.2

Weighting: For ongoing projects, there is equal weighting across all four evaluation criteria: Approach, Relevance, Accomplishments and Progress, and Future Work.

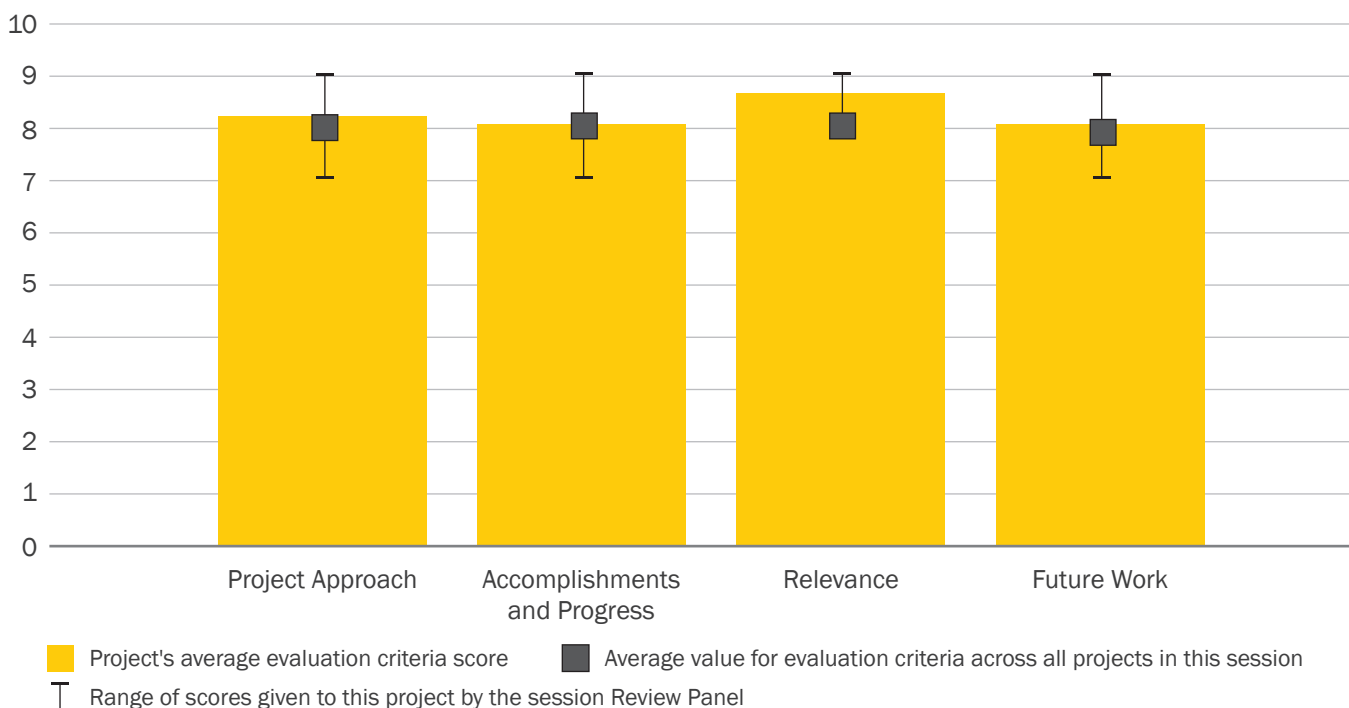



are already approved blending components into gasoline. American Process Inc. and Byogy are engineering an alcohol-to-jet demonstration scale facility for 2021 startup.

Overall Impressions

- The presentation clearly underlines the position of the project in building on the technology that American Process Inc. has already developed and is a logical extension. This gives the impression of a technology heading towards commercialization, with a relatively clear path. The use of membrane technology to remove product and allow an intensification of the process looks like a great benefit. Additionally, the shift in acetone production to further alcohol production looks like a worthwhile goal, but the presentation did not go into the consequences of that in terms of the metabolism of the organism and balancing co-factors and energy demands.

Overall, it is good to see this move forward as part of a full technology package and provide an alternative to other combinations of pretreatments/fermentation of sugars/product recovery schemes in the marketplace.

- This project investigates a novel approach to the mixed feedstock coming out of an acetone–butanol–ethanol fermentation by using an organism that would convert the acetone to isopropanol,

giving a feedstock much better suited for biofuel production. However, the project is also facing an acetone-to-isopropanol conversion that is much lower than expected. Further, it is unclear why the economics for this process allow lignin to be burned while the very detailed NREL evaluation requires lignin conversion to a high-value product. This inconsistency will need to be evaluated for the BETO program, as industry will likely gravitate to the least expensive processes.

- This project seeks to develop a novel process design using membrane-assisted fermentation and liquid/liquid extraction to enable lower energy removal of alcohol products. The economics seem good if targets are hit, partly due to the prior work American Process Inc. has done in providing a clean, economical sugar stream. The project is on track so far and is managed by a strict stage-gate program to ensure continued progress. Engineering the strain to shift production from acetone to isopropanol could pose a huge technical barrier, but this was not discussed, so I am not certain if the team has the right expertise to do this.
- This project was very well-presented and is awaiting Phase II approval. Critical success factors, quantitative progress towards metrics, and the value of future opportunities were clearly described. There are remaining challenges with strain engineering and sugar/product recovery, and the project is addressing them. Success would be a commercially competitive n-butanol process, without subsidy.
- Overall, this project has very good management and metrified goals using a stage-gate process to measure progress and direct go/no-go decisions. There are good technical achievements on all ends to allow small-scale demonstration of continuous fermentation and liquid/liquid extraction with novel configuration (separate C6/5 fermentations) and benchmark economics and life-cycle analysis. This is a very good demonstration of how the American

Process Inc. AVAP process sugars, which come from genetically engineered clostridia and good industry-academia collaborations, can be utilized effectively for mixed alcohols.

PI Response to Reviewer Comments

- The AVAP pretreatment provides clear fractionation of hemicellulose, cellulose, and lignin from a variety of biomass sources—about 90% monomeric sugar yield. Additional C5 sugar conditioning is applied for bacterial fermentation, which is less tolerant to inhibitors than yeast.
- Phase I established that AVAP C6 sugars do not require any conditioning, and C5 fermentation targets were reached after certain conditioning steps. The Phase I innovation with concurrent C5 and C6 fermentation productivity of the hydrolysates approached those of dextrose and xylose in a continuous fermentation scheme. The integration of non-toxic extractant to remove solvent from the fermentation permeate allowed recycle of raffinate and resulted in improved yield and productivity due to recycle of sugars, nutrients, and metabolic intermediates.
- Phase II will focus on the economics of the identified conditioning steps. The experimental matrix seeks to eliminate unnecessary steps and then determine the minimum necessary treatment to meet project targets. A complete mass balance of sugars and inhibitors will be constructed to evaluate the techno-economic optimum configuration. Finally, the whole process will be simulated, and process integration principles will be applied to find minimum utility requirement. Should there be excess lignin available, this can supply to the existing lignosulfonate market for additional revenue.
- Isopropanol producing Clostridia exist in the wild. State-of-the-art genetic engineering tools will be used by a subcontractor to rectify the isopropanol production in the robust AVAPClo clostridium. American Process Inc. will perform verification of the long-term viability of the resulting bacteria in the continuous fermentation system. The isopropanol conversion is targeted to be fully complete, but at least 80% is required to meet the current economic projections. We will update the life-cycle analysis and techno-economic model at the conclusion of the extended-duration runs.
- The separation of solvents from fermentation broth using liquid/liquid extraction proved efficient. The organic-to-aqueous ratio and number of solvent stages will be optimized, and scale-up for the commercial plant will be obtained via vendor.
- The DOE target MFSP at below \$3/gge by 2020 is achievable from AVAP process generated sugars using pine feedstock, as well as minimizing sugar loss in conditioning and performing successful genetic engineering with value engineering to reduce capital cost. The production of a lignosulfonate byproduct is a very real potential upside, if the process integration proves excess lignin is available.
- struggle to match. Moving forward with all viable options is the best path. Clearly, we did not perform to the level we had hoped. However, we do feel that there are some very positive results coming from the work performed. Given that we were venturing into unknown terrain, there was always a risk to delivering a scale-up ready process.

ENGINEERING CLOSTRIDIA FOR N-BUTANOL PRODUCTION FROM LIGNOCELLULOSIC BIOMASS AND CO₂

(WBS#: 2.3.2.203)

Project Description

This collaborative project between the Ohio State University, Green Biologics, and the University of Alabama aims to engineer novel Clostridium strains to produce n-butanol from low-cost lignocellulosic biomass and gases (CO₂ and H₂). Biobutanol is an advanced fuel that can fit the existing fuel infrastructure and directly replace gasoline in auto engines without modification. This project focuses on the metabolic engineering of Clostridium cellulovorans, a cellulosome-producing acidogen, for directly converting cellulose to n-butanol and ethanol, as well as carboxydrotrophic acetogens to produce ethanol and butanol from CO₂ and H₂.

Recipient:	The Ohio State University
Principal Investigator:	Shang-Tian Yang
Project Dates:	8/1/2015–7/31/2017
Project Category:	Ongoing
Project Type:	FY 2013–Incubator: DE-FOA-0000974
Total DOE Funding:	\$1,232,148

The engineered strains will be used in a consolidated bioprocess integrated with *in-situ* butanol separation to alleviate butanol toxicity and reduce energy consumption. The proposed co-fermentation process using both cellulose and CO₂/H₂ for biofuel production can greatly increase product yield from the biomass feedstock while also reducing greenhouse gas emissions by over 50% compared to current processes for butanol production. Metabolic and process engineering will be aided with proteomics and metabolomics analyses. The final optimized process is expected to be able to produce n-butanol from biomass, such as corn stover, at \$2.25/gallon (\$3.00/gge), which is much lower than the current butanol price (~\$6.25/gallon) in the chemical market and would be competitive to use in the fuel market.

Weighted Project Score: 8.2

Weighting: For ongoing projects, there is equal weighting across all four evaluation criteria: Approach, Relevance, Accomplishments and Progress, and Future Work.

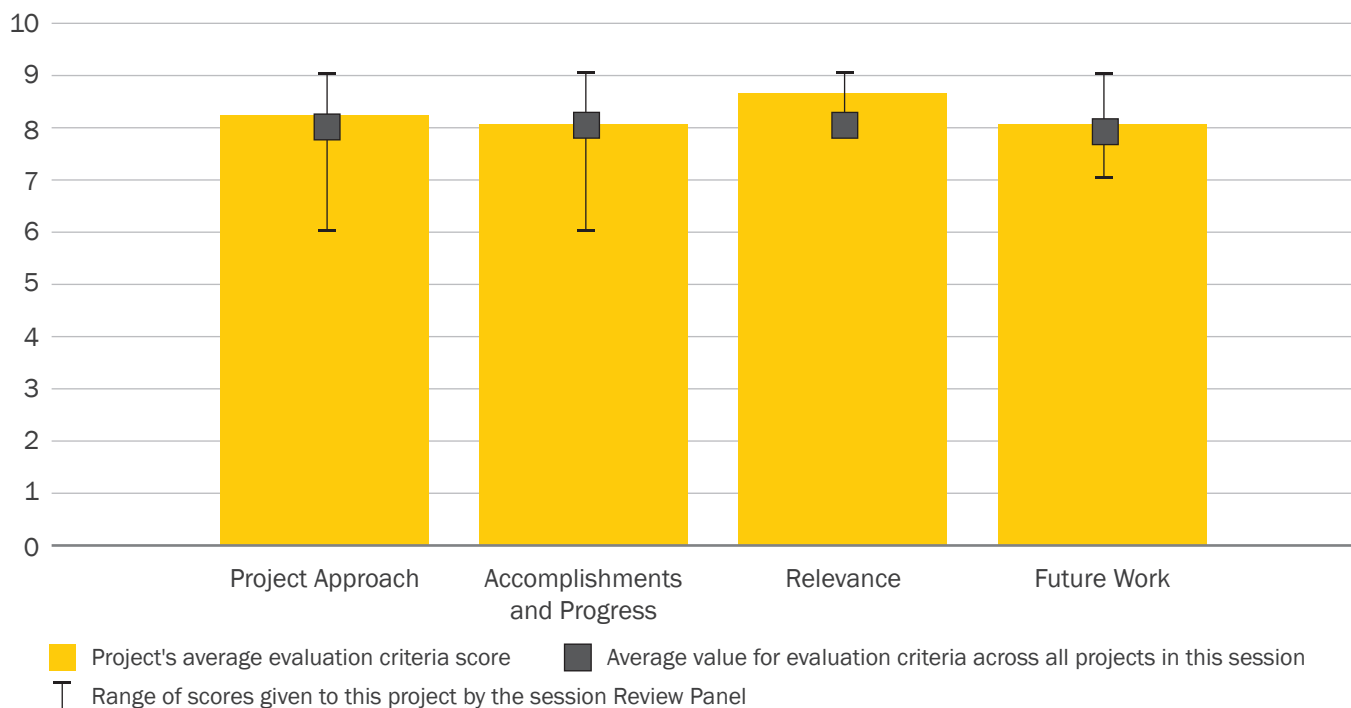



Overall Impressions

- The presentation gave a strong impression of a well-structured, well-organized project that has brought together the right set of partners. The team has shown an excellent mix of logical research steps and innovative approaches, with a high degree of understanding of the underlying biology. The use of milestones, work breakdown structure, and go/no-go decision points looks very good.

In terms of academia/industry partnerships and a project focused on BETO goals, this absolutely looks like a model project and a great use of funding.

- The PIs present a novel approach for direct conversion of biorefinery cellulose to biofuels through genetic engineering. Targeting cellulose as the substrate is a worthwhile goal, and if productivity issues can be developed, this might be a nice alternate approach to mixed alcohols. They further plan to improve carbon utilization by developing organisms that can consume CO_2 generated during fermentation and convert it into butanol. This is an

interesting and potentially promising approach, but the team needs to update their preliminary economics in the short term to evaluate whether the overall process has industrial viability.

- This team is taking a novel approach to butanol production using two species of *Clostridium*: one that can consume cellulose and another than can consume CO_2 . Engineering two organisms is a lot of work, so the team should do more thorough evaluation of the economics compared to the cellulosic organism alone (which should still offer benefit compared to the current state of the art due to CBP). Specifically, the team should determine how much benefit is gained from using the excess CO_2 , considering that external H_2 would have to be added.
- Furthermore, it may be simpler to just engineer the first organism to uptake hydrogen, which will boost the alcohol yield due to the extra redox (as shown by methyl viologen addition), which would mean less CO_2 production in the first place. Overall, the net stoichiometry and redox balance is the same, whether it happens in one organism or two.

For the targets set, the team has made great progress, but there is still a long way to commercialization with a lot of challenges, both biological and engineering.

- This is a well-organized project and is making good progress towards converting both biomass and “waste” CO_2 to fuel molecules in a CBP-like process. I personally favor the co-fermentation approach over asking one CBP organism to do everything. With similar strains, there is a reasonable chance of developing a robust single tank co-culture during both growth and production. Scale-up will be exciting!
- This is a very good example of an industry-academia relationship with direct contribution to BETO’s mission and goals. The project team came with novel solutions (e.g., co-culture) and overcame many technical gaps in the way with very structured and metrified goal setting and milestones deliverables.

PI Response to Reviewer Comments

We appreciate the positive comments and confirmation from the reviewers on our progress so far. Regarding engineering the cellulolytic strain to uptake hydrogen, this would be very difficult to do, as uptake hydrogenases are complicated and difficult to express in a heterologous host. In contrast, we are taking the approach to engineer the strain with minimal CO₂ and H₂ production, so most substrate carbon will be in the final product, butanol. Any CO₂ and

H₂ released from the cellulolytic strain will then be captured and used by the carboxydophilic strain.

We understand that there is a long way toward eventual process scale-up and commercialization of the technology. Nevertheless, to demonstrate the technology concept and its feasibility and economical and environmental benefits in 2 years would meet the goal of this incubator program. Further development and commercialization decisions will be based on the results of TEA and life-cycle analysis studies toward the end of the project.

SECOND-GENERATION MIXOTROPHY FOR HIGHEST YIELD AND LEAST-EXPENSIVE BIOCHEMICAL PRODUCTION

(WBS#: 2.3.2.205)

Project Description

The primary economic driver for second-generation biochemical/biofuel processes is feedstock cost and costs associated with feedstock's conversion to fermentable carbohydrates; therefore, maximizing the carbon yield of products is critical. However, with most conventional fermentations, at least one-third of the carbon feedstock is converted into CO₂ to produce the desired reduced products. To overcome this limitation, we have developed a fermentation technology called MixoFerm™ (also known as anaerobic, non-photosynthetic mixotrophy), which uses microorganisms capable of simultaneously consuming both organic (sugars) and inorganic (CO₂) substrates. With this technology, the CO₂ pro-

Recipient:	White Dog Labs
Principal Investigator:	Shawn Jones
Project Dates:	9/1/2016–9/30/2018
Project Category:	New
Project Type:	FY 2014—Incubator II: DE-FOA-0001320
Total DOE Funding:	\$1,539,826

duced during the catabolism of sugar can be fixed back into product and significantly improve the carbon yield.

In this project, we plan to demonstrate the improvements in carbon yield by producing acetone from cellulosic hydrolysates at a mass yield at least 130% the theoretical maximum from conventional fermentation. In addition to the improved yield, we will demonstrate industrially relevant productivities and titer using a continuous, cell-retention fermentation system. This technology is a transformational platform improvement for biochemical/biofuel production as it can dramatically improve cellulosic carbon yields and be applied to nearly any metabolite of interest.

Weighted Project Score: 7.3

Weighting: Approach–25%; Relevance–25%; Future Work–50%.

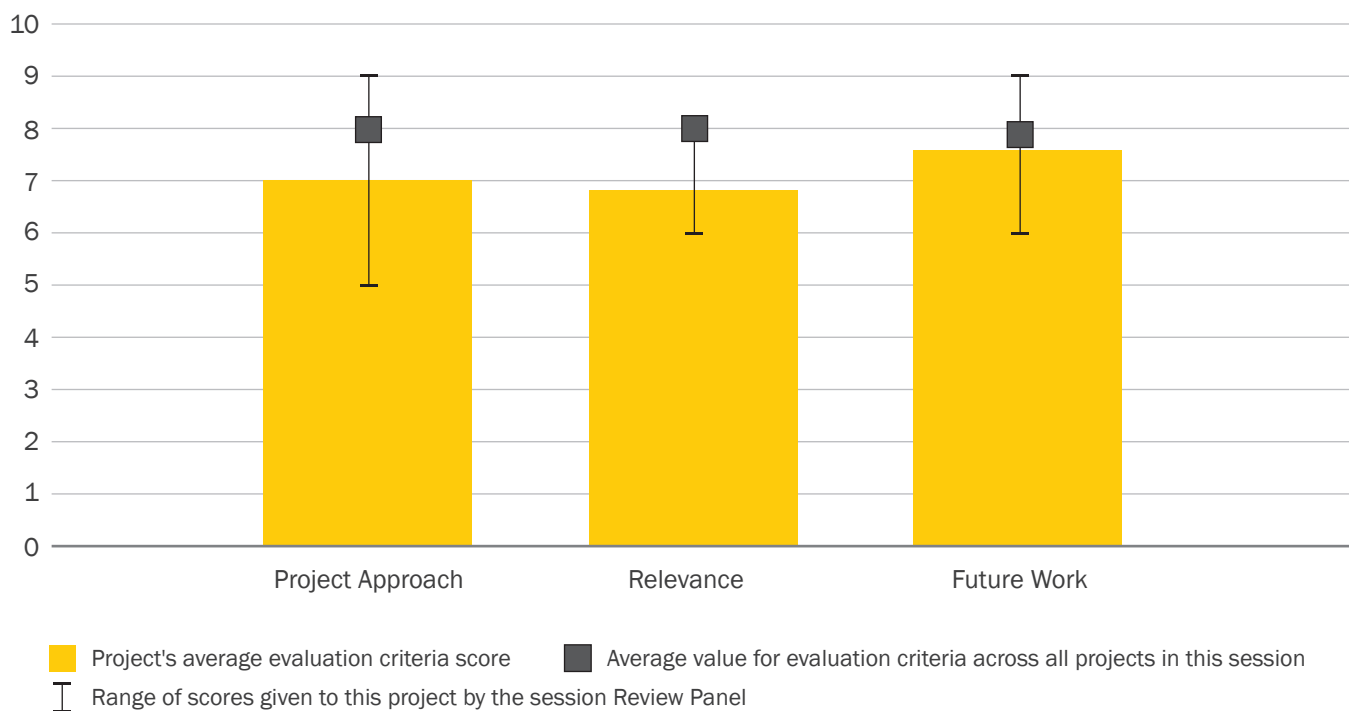

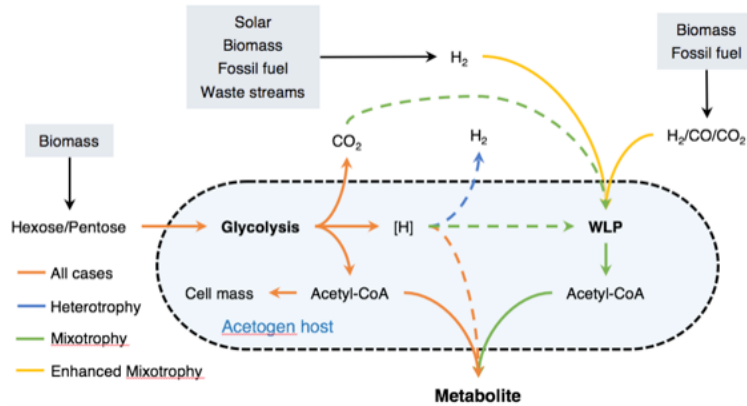

Overall Impressions

- The goal of using mixotrophy to bring in carbon through the Wood-Ljungdahl pathway in conjunction with fermentation looks interesting.

Adaptation of the strain to utilize glucose in addition to fructose through a combination of genetic manipulation and strain evolution was a good approach that appeared to work well. Addition of the Wood-Ljungdahl pathway and demonstration that the H_2 addition created the anticipated boost in yield on glucose looks good (the published work).

The approach to future work looks oversimplified and overly optimistic. Dealing with lignocellulosic hydrolysates, in terms of performance of the organism and issues with continuous fermentation, is likely to be a significant challenge.

- The PIs are using an interesting concept of CO_2 capture and conversion to improve the carbon yield of a process targeting acetone as a product. However, the lack of any TEA or idea of what the cost of their acetone will be in comparison to commercially produced material is a significant weakness within the context of the BETO program. The PIs need to work closely with their program manager to develop a more compelling description of their project and its justification as a potential industrial process.
- Using a mixotrophic organism maximizes the benefit of carbon from biomass by re-utilizing some of the CO_2 given off. White Dog Labs is developing an organism that uses this process to produce acetone

from cellulosic sugars. So far, they have made excellent progress toward their goals and have overcome initial challenges around glucose uptake and operation of a continuous cell-retention membrane. Beyond this project, a huge challenge will be scale-up for this fermenter configuration. In addition to the membrane fouling issue, contamination can be a big problem at industrial-scale continuous bioprocesses.

- In addition, it is not clear how acetone production will be profitable, regardless of technical success, since it is available at very low cost as a byproduct of the petrochemical industry. More market intelligence should be gathered, and then a thorough TEA performed.
- The opportunity to achieve 130% of conventional liquid fermentation yield is tantalizing. The project is making good progress to convert an acetogen to a mixotroph that can utilize biomass sugars. The cost-competitiveness of the process is an open question. The statement was made that the acetone could compete in the high-purity specialties market, but not the bulk market. Are there higher-value opportunities for this interesting technology?
- Overall, this is a good team with vast knowledge in strain engineering, fermentation, and process development, who can deliver, as illustrated in their recent publication, that increased yield of lignocellulosic sugars fermentations can be augmented with syngas fermentation. The business decision of focusing on acetone needs to be revisited, as this commodity chemical will be hard to replace with a biologically derived one. As the nature of this proj-

ect is to use acetone only to exemplify technology feasibility, this can be considered later as the project advances to higher TRL.

PI Response to Reviewer Comments

Most comments have been addressed in the previous comments. The additional comment made here regarding contamination of the process has been considered. We are planning for the entire fermentation process (both fermentation vessel and membrane filter) to be fully steam sterilizable in case of

contamination. Additionally, in the plant design, we are building in multiple independent fermentation vessels and filter systems so that if one is down, the entire process does not stop. We are also working with an industrial design firm with deep experience in proper design of fermentation systems to reduce the possibility of contamination. Obviously, we cannot design a system to completely prevent contamination, but we are taking precautions to reduce the possibility and building in strategies to correct for a contamination, should it happen.

FERMENTATION PRODUCTION OF TRICARBOXYLIC ACID CYCLE (TCA)-DERIVED CHEMICALS USING CELLULOSIC SUGARS

(WBS#: 2.3.2.206)

Project Description

Currently, the United States' chemicals industry is almost completely dependent on petroleum and natural gas feedstocks. Lygos is addressing this problem by developing microbial catalysts to convert renewable cellulosic sugars into higher-value commodity and specialty chemicals. Lygos is a part of the overall strategy to replace the whole barrel of oil and specifically targets "bio-advanced chemicals," compounds that are expensive to make petrochemically and that can be produced biologically for less than the petrochemical raw material cost. These are chemicals where the market size is constrained by production cost, and a lower-cost, biological process can enable market growth.

Recipient:	Lygos Inc.
Principal Investigator:	Jeff Dietrich
Project Dates:	10/1/2016–9/30/2018
Project Category:	New
Project Type:	FY 2014–Incubator II: DE-FOA-0001320
Total DOE Funding:	\$1,709,466

The goal of this project is to develop an integrated process from cellulosic glucose through fermentative production of a high-value chemical derived from the tricarboxylic acid cycle. Biochemicals produced from the tricarboxylic acid cycle are excellent targets for fermentative production: they can be produced at high efficiencies and rates, driving production costs down. The outcome of successful project completion includes a cost-advantaged process to a high-value biochemical with a net reduction in greenhouse gas emissions relative to the competitive, petrochemical process. Commercialization of the technology as a bolt-on plant in an integrated biorefinery can also improve integrated biorefinery economics, driving biofuel production cost to below \$3/gge.

Weighted Project Score: 7.8

Weighting: Approach–25%; Relevance–25%; Future Work–50%.

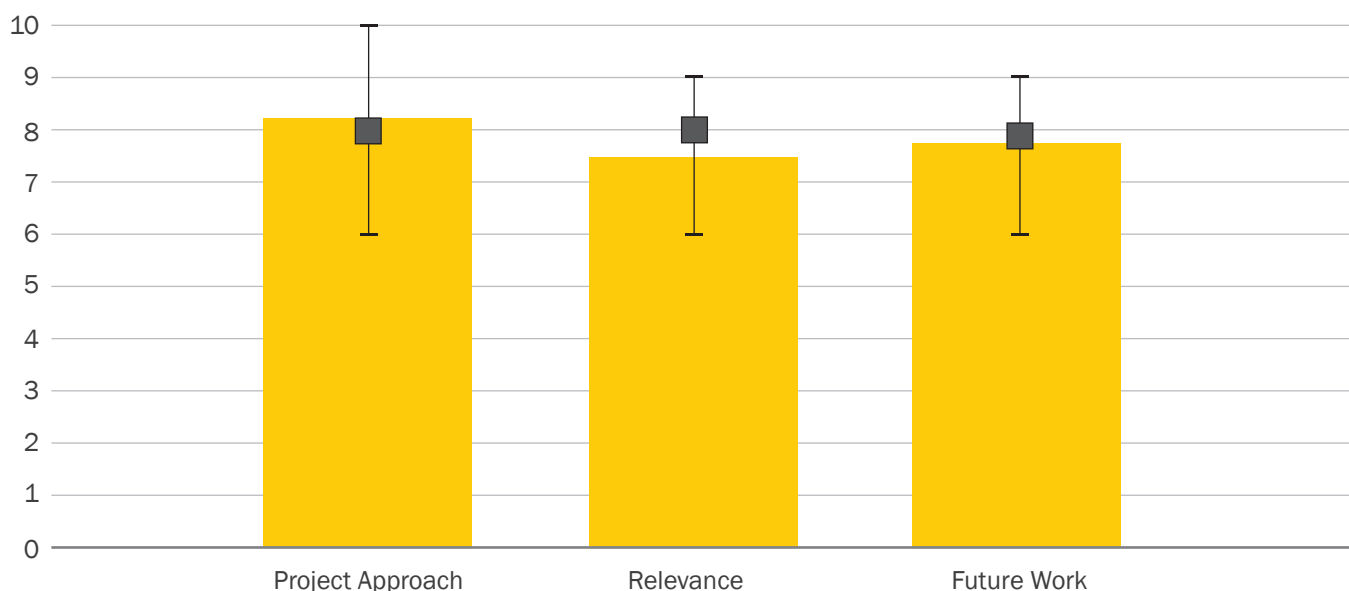

■ Project's average evaluation criteria score
 ■ Average value for evaluation criteria across all projects in this session
 Range of scores given to this project by the session Review Panel

Photo Courtesy of Lygos Inc.

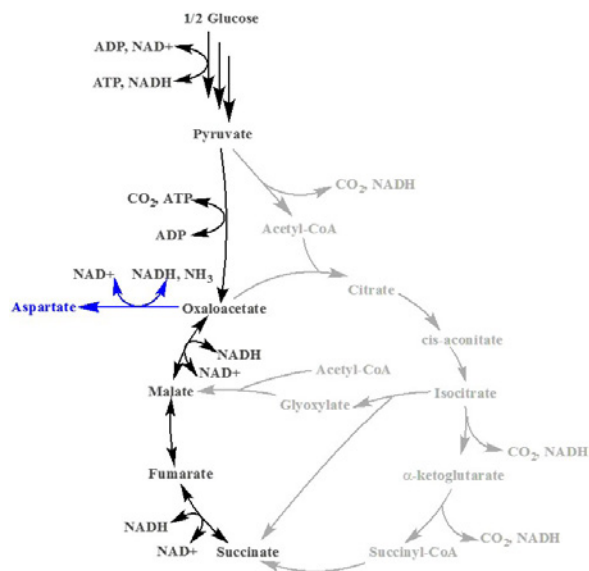

Overall Impressions

- The presentation was very clear, and the Lygos team demonstrated that they have a good grip on the steps they need to take to develop a novel process. The target of producing an organic acid from cellulosic sugar streams seems reasonable (with the caveat that the exact target molecule hasn't been disclosed). This aspect and the synthetic biology requirements for the project build on the technology platform that Lygos has built in the previous BETO-funded project. Overall, this looks like a great extension of that earlier work and again shows a well-thought-out approach.
- This is a very early-stage project and is based on a large amount of proprietary information. The broad strokes of the plan seem reasonable, as it appears to be a conventional organism-identification/engineering process, but a more detailed evaluation will need to wait until more results are obtained.
- Lygos is developing an acid-tolerant yeast strain for production of an undisclosed organic acid two steps away from the reductive tricarboxylic acid cycle. Due to CO_2 incorporation in the reductive tricarboxylic acid cycle, theoretical yields are very high. Technically, the team seems very well-positioned to hit project goals.

- Lygos demonstrated at Stage 1 incubator that they are capable to reduce effectively to practice the design-build-test-learn cycle, even without automation, with a clever biosensor and high-quality data analysis approach. I'm confident that they can deliver on the 2017 milestone and enable another BETO relevant product to enable a more sustainable production of organic acids utilizing waste stream (CO_2).

PI Response to Reviewer Comments:

- To clarify the difference in work plan between years 1 and 2: In year 1, we aim to demonstrate the activity of novel or poorly characterized enzymes in the engineered host; we divided the work plan into three modules, with each focusing on addressing one of three enzyme activities required for product biosynthesis under the anticipated commercial fermentation conditions. The goal at the end of year 1 is to successfully integrate all three modules into a single production host (i.e., providing the prototype strain). Achieving this goal will have addressed the majority of the enzyme and pathway risk. In year 2, the focus is placed on strain and process optimization; mass balances on glucose consumed will be used to assess the pathways that should be up- or down-regulated to direct flux away from biomass, CO_2 , and byproduct formation. Additionally, in year 2 we begin both fermentation and downstream process development, two aspects of the technology that are stage-gated until after the prototype strain is successfully constructed.

The fermentation milestones are all assessed using the same supplier of cellulosic glucose (and same lot number of glucose). This choice was intentional and allows us to perform longer-term studies to assess how strain, fermentation, and downstream processing process modification effect impurity levels at each stage in the integrated process (and enable us to draw more accurate comparisons with data from years earlier). Based on the impurity profile reported by the commercial supplier and our

in-house knowledge of strain tolerance, we do not anticipate impurity buildup to reach toxic levels in the fermentation. However, we will continue to monitor this (potential) problem over time and modify the strain or fermentation process as needed if issues are uncovered.

The reviewer's comment to provide more technical details in future public presentations is noted, and we look forward to providing a more in-depth discussion of the technology shortly as the intellectual property is published.

INTEGRATED PROCESS FOR COMMERCIAL PRODUCTION OF FARNESENE FROM DOMESTIC LIGNOCELLULOSIC FEEDSTOCK

(WBS#: 2.3.2.207)

Project Description

This project proposes an integrated process for commercial production of farnesene, a versatile platform chemical, from domestic lignocellulosic feedstock. This project will develop an engineered yeast strain and a scalable, lignocellulosic-based manufacturing process for the production of farnesene for fuel and bioproducts from woody feedstocks. The work will be carried out by Amyris, Renmatix, and Total, three commercial entities with complementary capabilities.

Renmatix will employ its Plantrose® process that uses supercritical water to fractionate hemicellulosic and

Recipient:	Amyris
Principal Investigator:	Gale Wichmann
Project Dates:	10/1/2016–12/31/2019
Project Category:	New
Project Type:	FY 2016–MEGA-BIO
Total DOE Funding:	\$7,000,000

cellulosic sugars from pine. Amyris will develop a yeast strain and process for cost-effective conversion of Renmatix's cellulosic sugars into farnesene that is of equal quality to that produced today using cane syrup. This will involve engineering a farnesene manufacturing strain to consume the xylose found in biomass-derived sugars that will be resistant to cellular inhibitors present in the cellulosic sugar feedstocks. Total will conduct a thorough engineering study and TEA to provide production cost estimates and develop a rigorous life-cycle analysis to assess the environmental impact in support of the project's go/no-go decision points.

Weighted Project Score: 6.8

Weighting: Approach–25%; Relevance–25%; Future Work–50%.

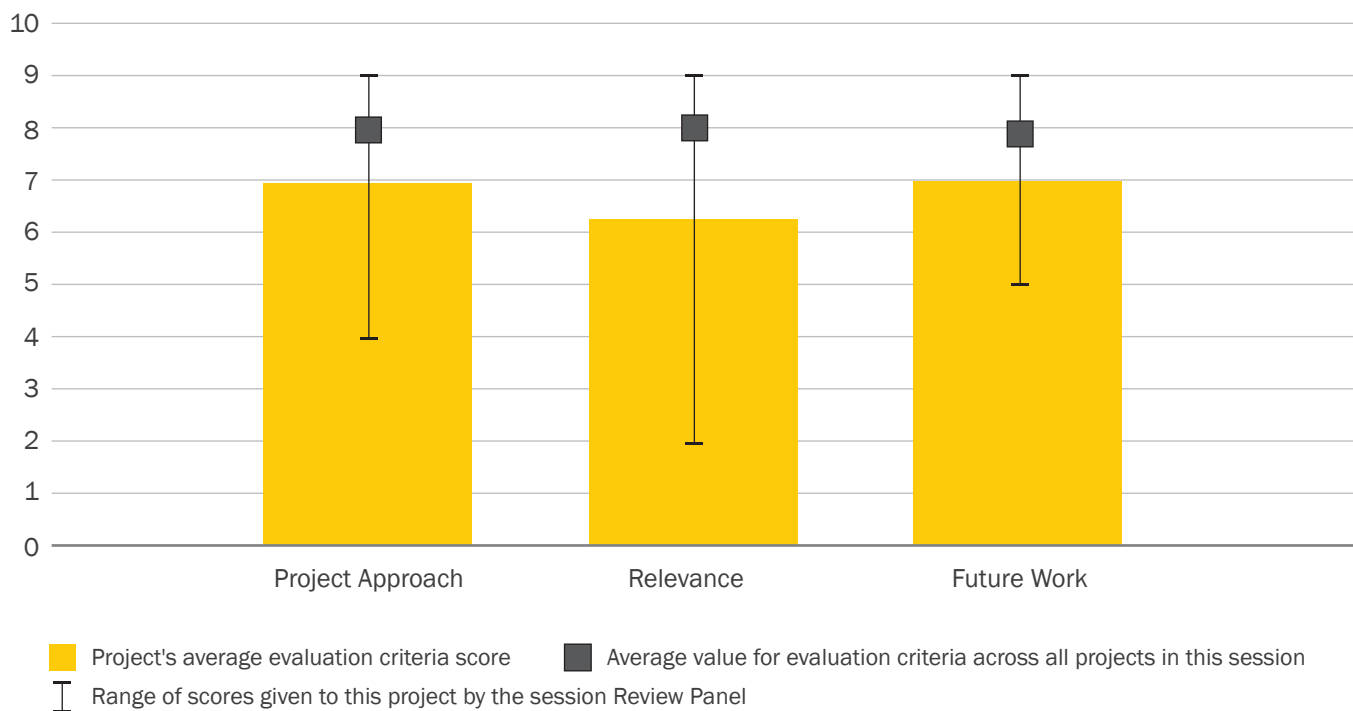

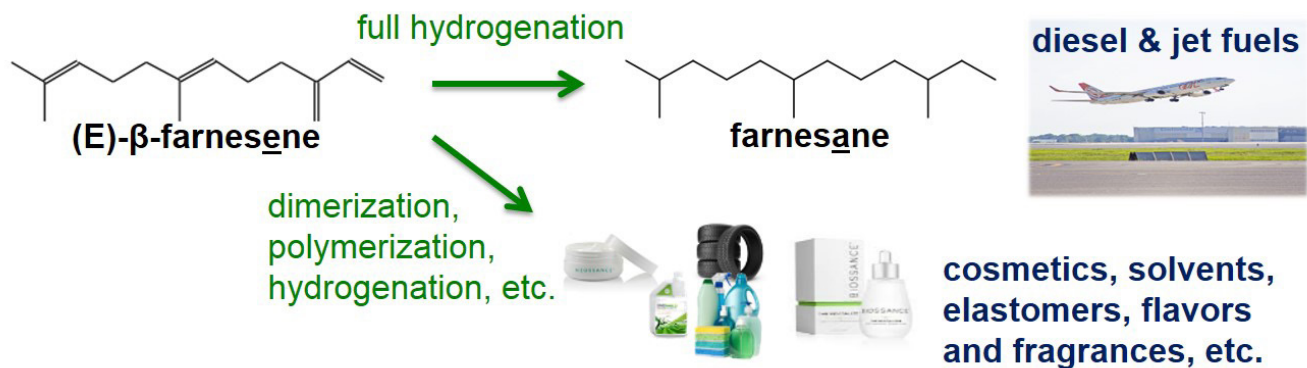

The final project goal is to develop a manufacturing-ready process to produce farnesene from cellulosic sugar in the United States at a manufacturing cost of \$2.00/L.

Overall Impressions

- The project looks like a very appropriate combination and further extension of existing technologies at the partner companies. This builds on each of their expertise and has a goal that will provide a useful commercial process. It seems to have a good blend of solid technical foundation (e.g., Amyris' current farnesene process) and technical risk (extending to cellulosic sugars). There are technical challenges that can obviously be worked on separately, but a key component for the project will be cross-checks between the strain development effort and the pretreatment process development effort and regular transfers of pretreated material.

Overall, the project looks to have been set up very well, making good use of the partners' expertise.

- Although the project was presented as an approach to fuels, the discussion seemed to pivot when the costs were examined to become a project targeting products. Close coordination of the Amyris team with BETO management will help to identify their exact interest in carrying out this work and improve its message, as they already make farnesene profitably in Brazil.
- Amyris is using this project to lower the cost of farnesene by the use of cellulosic sugars provided by Renmatix. The process for farnesene produc-

tion is relatively mature compared to other product targets in the BETO portfolio; thus, this work is incremental in nature rather than groundbreaking. Technology is already available for xylose utilization in yeast, so it is rather straightforward to introduce these into the farnesene production strain. The project is already at a very high TRL, so this would be more appropriately funded by other mechanisms (e.g., loans) than by a BETO grant. In addition, since farnesene is not cost-competitive as a fuel, the product will likely be directed to small niche markets for the foreseeable future.

- This is a strong project with partners that have extensive experience in their respective areas. Farnesene is already profitable in non-fuel markets at \$2/L from sugarcane syrup. Extending the feedstock range of the yeast to biomass-derived sugars and incorporating a new C5 metabolic pathway seems like a logical extension. The technical milestones are reasonable based on the SOT in the industry.

PI Response to Reviewer Comments

- We definitely were planning to use evolution strategies as well as rational engineering strategies for overcoming inhibitors.

Earlier DOE-funded work at Amyris gives us confidence that our xylose utilization goals are feasible. However, the final >95% consumption goal is for the end of the project in 2019, not for the end of this year (2017).

For both the xylose consumption and the tolerance goals, we certainly plan to leverage existing technology where it is available to us. However, for IP and licensing reasons, it is often not possible to work with outside entities, either academic or industrial.

To address the reviewer comment about using a BETO grant versus a loan for this work, it is important to remember that while there are markets in which Amyris can sell farnesene profitably, neither

Amyris nor Renmatix are yet profitable companies. Therefore, neither company can afford to fund projects (or would be willing to take a loan) for any project that does not have immediate revenue potential. Funding (in the form of a grant) is necessary to ensure a cellulosic-farnesene project is conducted. While both Renmatix and Amyris see the benefits that could ensue from this project, there is currently no logical justification to fund this work internally.

BIOLOGICAL CONVERSION OF THERMOCHEMICAL AQUEOUS STREAMS

(WBS#: 2.3.2.301)

Project Description

This project aims to develop integrated biological strategies to valorize the “waste” carbon present in thermochemical aqueous streams from pyrolysis processes.

Overall, this project has two aims: first, we will develop robust analytical methods to characterize aqueous streams from thermochemical processes (e.g., fast and catalytic fast pyrolysis) with national laboratory, industrial, and academic collaborators; second, we are adapting the biological funneling idea—originally developed for lignin valorization—to convert carbon in thermochemical waste streams to value-added products (PHAs).

The motivation for this project is to transition from a process cost for wastewater to a process credit wherein process economics are improved via a value-added co-prod-

Recipient:	National Renewable Energy Laboratory
Principal Investigator:	Gregg Beckham
Project Dates:	10/1/2013–9/30/2017
Project Category:	Ongoing
Project Type:	AOP
DOE Funding FY 2014:	\$500,000
DOE Funding FY 2015:	\$750,000
DOE Funding FY 2016:	\$750,000
DOE Funding FY 2017:	\$750,000

uct. To date, we have conducted characterization of over 25 thermochemical aqueous streams with near complete mass closure and have identified >200 compounds, in turn enabling a down-selection to an ex-situ catalytic fast pyrolysis stream for focusing future strain development efforts. For the second aim of the project, we are employing a robust aromatic-catabolic microbe, *Pseudomonas putida* KT2440, to convert a wide range of carbon in aqueous streams, and we have demonstrated that over-expression of the native protein quality control machinery enables a two-order-of-magnitude improvement in the toxicity tolerance—a key scientific challenge for making

Weighted Project Score: 8.5

Weighting: For ongoing projects, there is equal weighting across all four evaluation criteria: Approach, Relevance, Accomplishments and Progress, and Future Work.

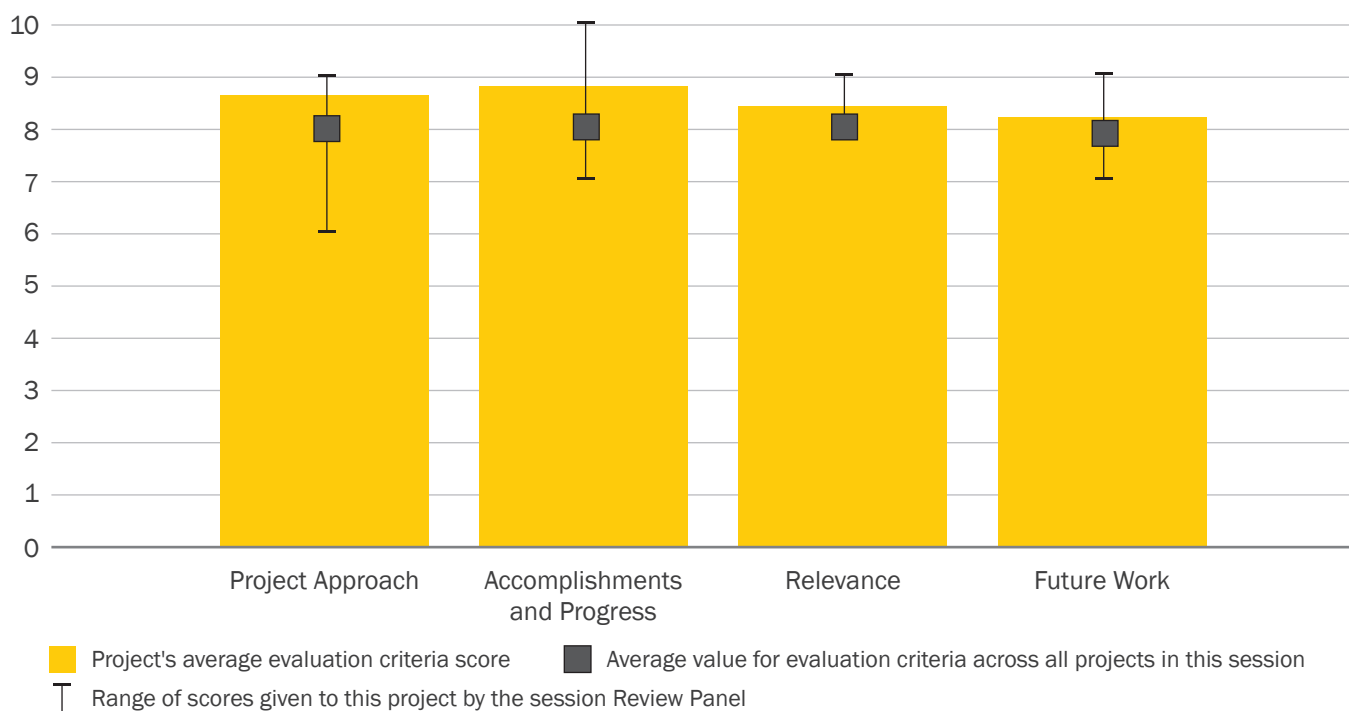

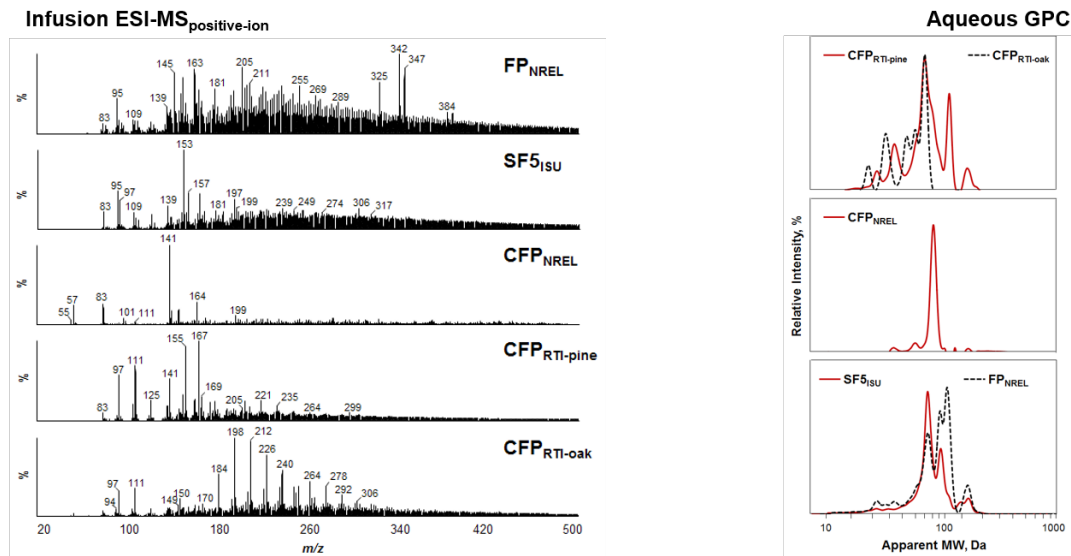

this process concept contribute positively to a \$3/gge cost target for 2022 via thermochemical conversion.

Overall Impressions

- The project looks well-managed, has a good and economically relevant target, and has made great progress so far. The chemical analysis of the waste streams and reaching the degrees of mass closure seen is in itself a tour de force. The pathway engineering strategy in *P. putida* looks very sound, with pathways identified to address the molecules seen in the waste streams. Only the biology will tell us what the limits of adding several new pathways to a single host may be, in terms of robustness or performance.

The routes taken to increasing tolerance to protein damage have produced very good results (a 200x improvement in tolerance is impressive and suggests application to other systems). It would be good to bear in mind that, given that the strains may be able to actively digest the toxins, a fed-batch process may help the strains tolerate much higher levels of toxins than can be handled in batch.

It would be interesting to think through the economics of applying the system to actively detoxifying other process streams, leaving behind sugars, for

example, that can be readily utilized by a yeast system.

Overall, this a great effort by the team, producing novel technical paths and excellent results.

- The PIs are developing one of the more exciting processes described, and the number of questions are a result of probing the potential of this approach. The ability for a single organism to navigate a huge range of functionalities and structures has the potential to be applicable in a wide range of areas. There are clear challenges, but the PIs recognize what is needed. Although it is a significant challenge to find an organism that can deal with a mixture of hundreds of materials, the PIs have found routes to make the funnel bigger. The presentation tells a nice, positive story regarding a concept that is quite straightforward.
- Aqueous waste streams account for 3%–10% of biomass carbon, currently sent to wastewater treatment. This project aims to create a monoculture that can not only remediate this stream, but turn it into a value-added product. One of the biggest accomplishments is the analytical characterization of these streams. *P. putida* was engineered to broaden substrate range, and a surprising increase in tolerance was obtained by overexpression of just GroES/EL

(heat shock 10 kilodalton protein 1 (Hsp10)/another protein of 57 kilodaltons).

The tolerance improvement here is likely sufficient. The organism has been engineered for utilization of various substrates, but the biggest challenge ahead is improving the utilization rates so that they will match the waste production rate without needing an enormous bioreactor. Also, if the waste treatment step is to be avoided, the organics have to be removed to an extremely low level. This is often challenging as catabolic pathways shut off at low substrate concentrations.

- Waste valorization is one of the keys to cost-effective biorefineries, both bio- and thermo-conversion processes. The use of bio-funneling is a clever approach to upgrading myriad waste carbon components into a value-added product, and possibly saving catalyst cost by decreasing the severity of the thermochemical conversion (allowing bioconversion to “mop up”). Since the 2015 review, PHA has

been identified as an exemplary product, and a TEA is in progress and should lead to quantitative metrics moving forward.

- This is a good example of high-risk/high-gain project. It is a very ambitious project with dynamic moving targets of variability of waste stream composition and multiple toxicities (e.g., membrane fluidity, protein generation and repair, global stress response, acid tolerance, etc.). These challenges make it difficult to judge if this project will make it to the end goal, which is transfer to industry to develop a fermentation process for the complete use of wastewater from thermochemical processes to a biobased product. If successful, it will make a big impact on the economics of the thermochemical processes.

PI Response to Reviewer Comments

We thank the reviewers for the positive feedback and constructive comments. We completely agree that the approaches being developed here could potentially be useful for hydrolysate cleanup.

LIGNIN UTILIZATION

(WBS#: 2.3.4.100)

Project Description

This project aims to develop viable, scalable, and robust processes to produce value-added co-products from lignin, which will contribute \$2–\$4/gge MFSP credits to the 2022 BETO hydrocarbon fuel cost target of \$3/gge. The project was founded upon the economic necessity to produce chemicals alongside fuels in a lignocellulosic biorefinery to ensure renewable hydrocarbon fuel selling prices are competitive with fossil-based fuels.

The Lignin Utilization project has two technical goals: first, we aim to isolate and depolymerize lignin-rich streams to high yields of aromatic monomers, and second, we aim to employ the “biological funneling” approach to convert heterogeneous slates of aromatic compounds to single-target chemicals, thus overcom-

Recipient:	National Renewable Energy Laboratory
Principal Investigator:	Gregg Beckham
Project Dates:	10/1/2016–9/30/2019
Project Category:	Ongoing
Project Type:	AOP
DOE Funding FY 2014:	\$1,000,000
DOE Funding FY 2015:	\$1,000,000
DOE Funding FY 2016:	\$1,000,000
DOE Funding FY 2017:	\$1,500,000

ing the heterogeneity challenge in lignin valorization. For the 2022 cost target, we have chosen adipic acid as a target from lignin via a bio-derived muconic acid intermediate.

To date, we have developed two high-pH treatments to recover high yields of lignin from whole biomass and are beginning to develop active, robust catalysts to further depolymerize lignin-rich streams using oxidation at high pH level. For adipic acid production, we have

Weighted Project Score: 8.7

Weighting: For ongoing projects, there is equal weighting across all four evaluation criteria: Approach, Relevance, Accomplishments and Progress, and Future Work.

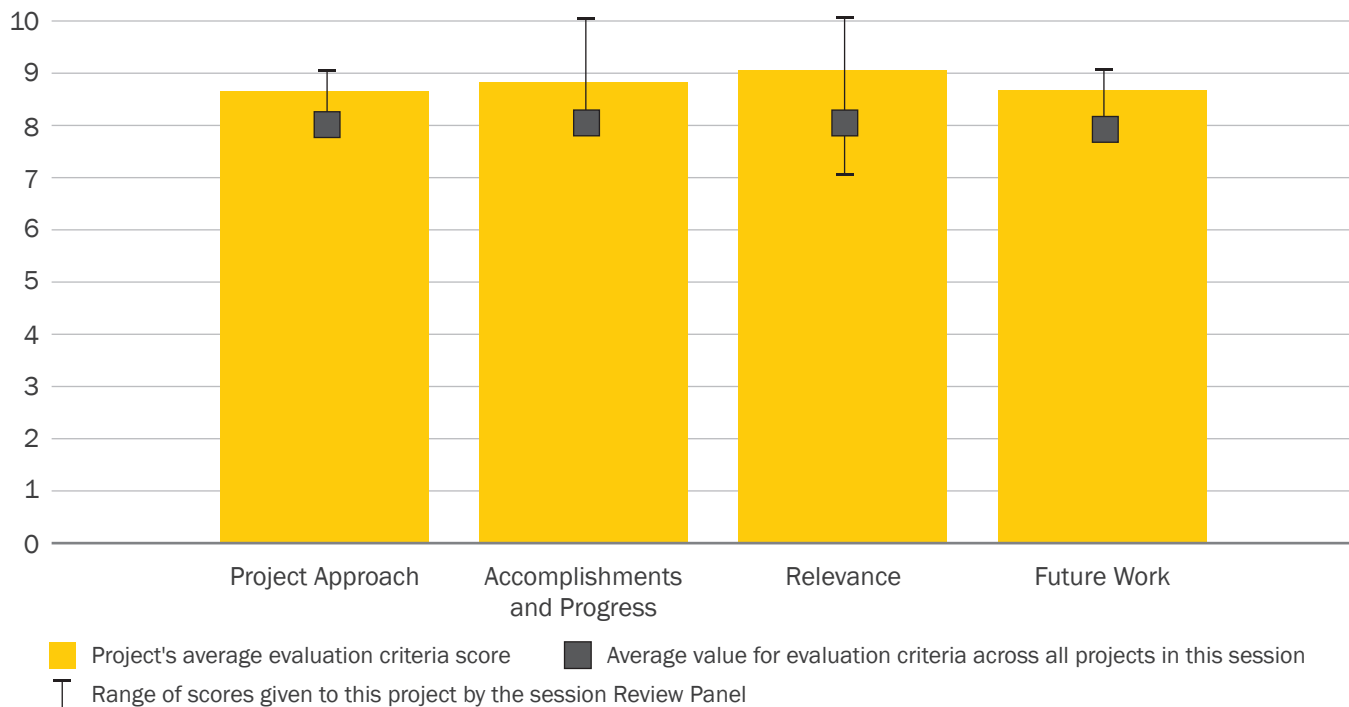

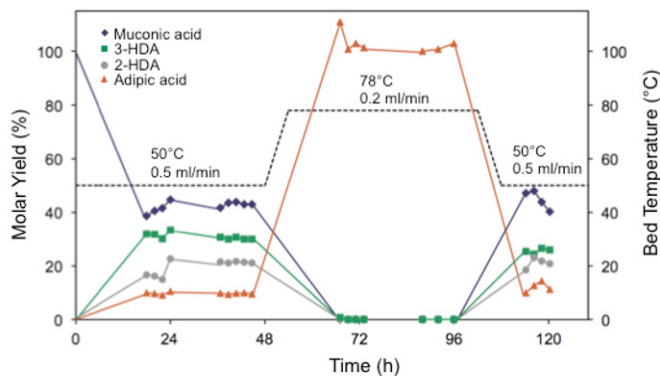

demonstrated nearly 100% yield from a few relevant lignin-derived model compounds. The 2022 outcome of this project will be a fully integrated process from lignin to adipic acid at yield targets predicted from TEA.

Overall Impressions

- The project direction looks good. It has the right balance of analysis to understand the chemistry of the depolymerization processes and catalysis and process development. Obviously, it is closely tied to the Targeted Microbial Development project, and those appear to be closely managed. The approach covers a lot of ground in a logical manner and looks to be making good progress.

The final determination for the success of the project will perhaps not be whether you can break down lignin chemically, or whether products can be used by a microbial strain (although both of those are great to demonstrate and certainly worthwhile to keep developing), but whether the process is economic in its own right; doesn't interfere with the economics of the sugars process (as is being addressed in this project); and is modeled properly in the TEAs covering both parts of a process scheme. Looking at some of the other TEAs, it can start to look like the lignin process is being used as a way to say "and then we reach \$3/gge in 2022 with lignin valorization." It would be good to start making sure the numbers being applied to other TEAs from the

lignin-derived co-product have some foundation in a modeled-out, full-on lignin stream/biofuel process.

- Lignin deconstruction and conversion is a critical part of biorefinery development and will be a key contributor to meeting BETO's goals. This project is doing an excellent job of addressing this challenge and has come up with interesting potential solutions to (1) converting lignin into a mixture of more-tractable low-molecular-weight compounds for eventual conversion, and (2) demonstrating high-yield conversion of lignin models (coumarate, ferulate) to muconate, an adipic acid precursor. Although the focus has been on NREL's current alkaline pretreatment, the project plans to make catalytic systems that work with lignin from any pretreatment process...however, this seems like a very large challenge, so it might be wise to test depolymerization and catalytic conversion with lignins from a range of known pretreatments.

While all the pieces are not yet in place, the PI has done an excellent job of breaking the project down into manageable parts and addressing each part in turn. As a result, the project has a good chance for success.

- The Lignin Utilization program is essential to reaching the \$3/gge objective, as lignin valorization is a key assumption of all the TEA performed. Nonetheless, this work is extremely challenging, and the team has done an amazing amount of work to de-risk both lignin depolymerization and upgrading. The team has also put together two steps that require very different scientific disciplines and, in addition, the need for complex analytical chemistry. The project has been very well-managed so that these groups all work well together, united toward the same overarching goals.
- It is commonly accepted now that lignin valorization will be the key to the success of near-term biorefineries. This is a well-designed approach to a

difficult problem. The proof of concept for each of the pieces of a process has been demonstrated (lignin extraction, depolymerization, and bioconversion to muconate). The challenge ahead is to integrate these pieces into a relevant process (could be pulp and paper first) with bioconversion of complex lignin aromatics. A number of new unit operations are being proposed, so keep an eye on the TEA and good luck! This project has the possibility to change the biorefinery equation.

- Overall, this is a very good project and a great example of how to connect things from end to end. This should be, in the future broken, down to lignin de-polymerization group (pretreatment, analytic, separation etc.) and upgrading group (i.e., Agile BioFoundry, Targeted Microbial Development, etc.).

PI Response to Reviewer Comments

- We thank the Review Panel for the positive feedback. As noted, we are conducting TEA with detailed models for the lignin valorization process trains. These TEAs are now being incorporated in the BETO MYPP to outline strategies and key process metrics to meet the out-year \$3/gge cost goal through lignin utilization. We agree that this will be a key component of lignin valorization process economics.

We agree that the catalytic challenges here are considerable. Namely, the primary challenge going forward is developing catalytic systems that can cleave both C-O bonds and C-C bonds, the latter of which is especially challenging to do selectively at moderate temperatures. Fortunately, many groups are now working on C-C bond cleavage from a mechanistic standpoint, so we can leverage work from the scientific community in this vein to develop improved oxidation catalysts in a rational manner, which is a key aim going forward in the Lignin Utilization project.

We thank the reviewers for the positive comments on the integration and multidisciplinary aspects of the project. In terms of the way that this project is managed, we have tasks focused on analytics, lignin depolymerization (including pretreatment), and conversion to value-added compounds (both catalytically and biologically). In addition, the Lignin Utilization project works closely with other projects to leverage expertise and capabilities, including the Targeted Microbial Development project (for strain development), the Separations Consortium and the Separations Development and Application projects, and the various catalyst projects being funded by BETO at present, including the Computational Chemistry and Physics Consortium and the Advanced Catalyst Synthesis and Characterization Project.

RENEWABLE CARBON FIBER CONSORTIUM

(WBS#: 2.3.4.200-202)

Project Description

The primary, overarching objective of the Renewable Carbon Fiber Consortium is to demonstrate the production of carbon fiber-based materials from acrylonitrile (ACN) produced from lignocellulosic biomass-derived sugars at a modeled ACN cost of \$1/pound. The ultimate deliverable at the end of the project is 50 kg of ACN, which will be converted into a carbon fiber component for performance testing.

To accomplish this overall goal, the Renewable Carbon Fiber Consortium work is split into two phases. During Phase I (20 months), the team has been exploring the technical and economic viability of three biological/

Recipient:	National Renewable Energy Laboratory
Principal Investigator:	Adam Bratis
Project Dates:	8/1/2015–12/31/2018
Project Category:	Ongoing
Project Type:	FY 2013—Carbon Fiber: DE-FOA-0000996
Total DOE Funding:	\$5,325,790

catalytic hybrid pathways that use biomass sugars as feedstocks at bench-scale and will demonstrate the production of at least 50 grams of ACN with concomitant polymerization, spinning, and testing of fibers. In Phase II (also 20 months), the team will optimize ACN production efficiencies and address remaining cost drivers for one of the pathways and scale up to 50 kg of ACN production. This material will then be used to produce a carbon fiber composite that will be tested side by side with a conventional carbon fiber composite to ensure equivalent product properties.

Weighted Project Score: 8.9

Weighting: For ongoing projects, there is equal weighting across all four evaluation criteria: Approach, Relevance, Accomplishments and Progress, and Future Work.

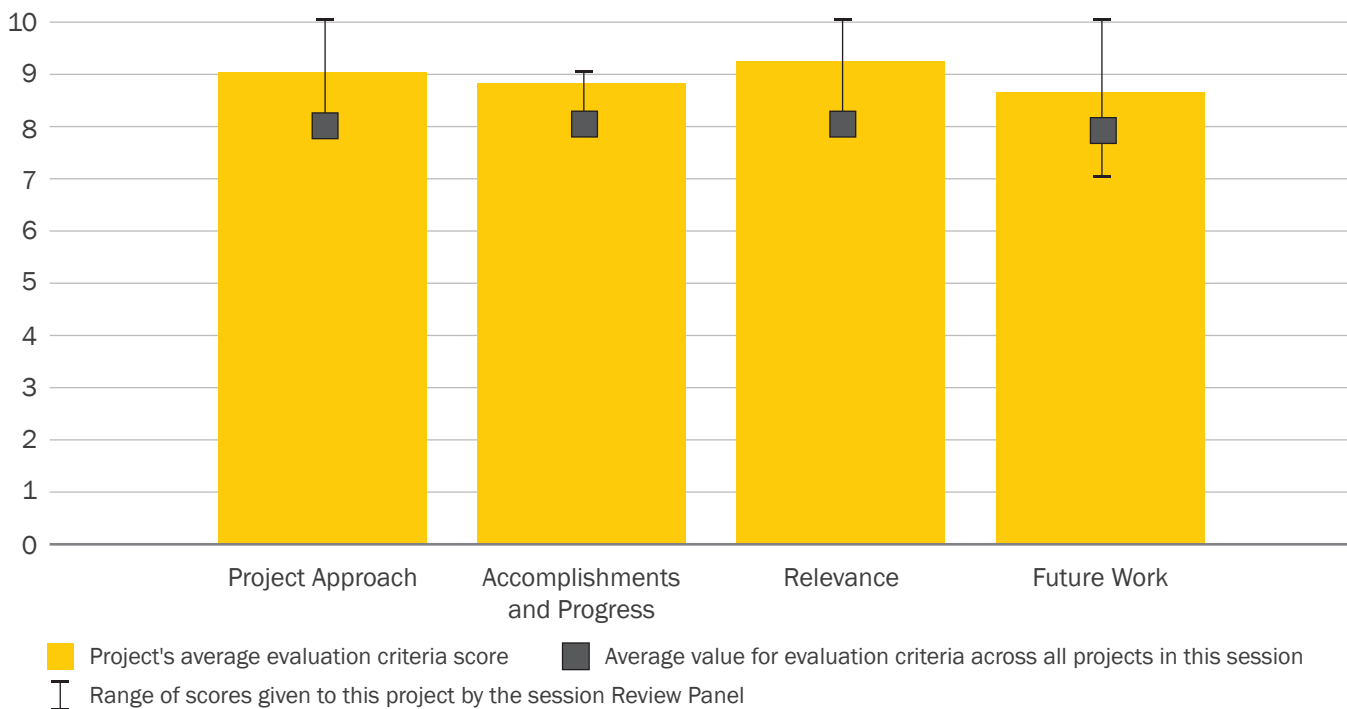

Small scale fiber production



To achieve these outcomes, the Renewable Carbon Fiber Consortium has assembled a team of experts across the value chain from the national labs (NREL, Oak Ridge National Laboratory, and Idaho National Laboratory), academia (University of Colorado, Colorado School of Mines, Michigan State University) and industry (Biochemtex, Johnson Matthey, DowAksa, and Ford).

Overall Impressions

- Overall, this is a really impressive project, not only for the technical trajectory, but the way the project has been run: the setup of the consortium, logical evaluation of options, use of TEAs, identification of advantages over other technologies, checking of the performance of the outputs early on, and engagement with industry partners. All these hit the right points. In several ways, this looks like a model project for public/private collaboration.
- The bio-ACN team has accomplished an elegant combination of biochemistry and catalytic conversion to develop a new route to a well-recognized industrial chemical. The effort proves that just because the target is simple, one should not assume that good science cannot be done. This project should be considered as one of BETO's wins for the program. It is a very nice effort and one that has an excellent potential for commercial success. Further, the work has been submitted as a publication to Science, and I believe it will have an excellent chance of acceptance.
- The current ACN production from propylene is a complex and hard-to-control reaction, with a toxic byproduct. This program will provide a renewable route, which will also be cost-effective according to the TEA. The team has achieved all Phase I goals and appears to be on track for achieving the ultimate \$1/pound goal. A key decision the team must face is to engineer the 3-hydroxypropionic acid (3HP) organism for use of cellulosic (second-generation) sugars at low pH or use lactic acid organism which is ready, but has less ideal downstream process. The barrier to the 3HP strain using the biomass sugars is unclear. Is it the C5 content or the presence of inhibitors? Either of these could be overcome with some research effort. Before making a decision, do a return on investment assessment of the extra work it will take to accomplish this. Lactic acid may be quicker to market, but with 3HP you can also leverage other outlets besides ACN (such as acrylic acid).
- The presenter made a strong case for ACN and carbon fiber as targets for sugar upgrading. The chemistry and biology are mostly known, so the project is empirically determining the best combination of strains, intermediates, and process. Sufficient ACN has already been made for carbon fiber production and testing (no results presented). The project is also developing alternative new nitrilation chemistry for ACN production. This is a very interesting project.
- Overall, this is a good project and on the right track. Achieving high TRY of low-pH 3HP or lactic acids with a high quality of product in the end (minimal impurities) is going to be a prerequisite for this project. The project team is well aware of the challenge and is partnering with the right teams to overcome it. The team is advised to partner faster with industry to accomplish this or its build own strains, which might take longer than the project and BETO

can afford. If the latter is the case, it is advised to use the Agile BioFoundry and/or advanced strain development and evolution tools to accelerate. The nitrilation and generating relatively pure bio-ACN seem to be feasible.

PI Response to Reviewer Comments

- We thank the Review Panel for the positive comments and constructive feedback.

We note that we have not met the Phase I targets for the 3HP strain in terms of productivity and yield on biomass hydrolysate, but we have done so for lactic acid. The 3HP strains are quite inhibited by compounds in biomass hydrolysate. Moreover, the overall yield of 3HP in *E. coli* is lower by at least a factor of two relative to lactic acid, from a theoretical yield perspective.

While we fully agree with the reviewer that overcoming biomass hydrolysate toxicity and C5 sugar utilization is a problem that can be solved, it will likely be a fairly long undertaking relative to the overall integrated process development timeline for

this project. As such, we do not feel that this is a realistic effort to achieve the Phase I targets for TRY for 3HP production. Moreover, the higher inherent yields (approximately double) on a mass basis of lactic acid relative to 3HP, the ability to produce lactic acid at low pH industrially, and the ability to produce lactic acid anaerobically suggest that lactic acid is advantaged from a biological perspective. As the Review Panel notes, the chemistry is somewhat different and requires more steps for lactic acid, and we are currently conducting rigorous TEA and life-cycle assessment to understand the tradeoffs. Preliminary comparative TEA of the 3HP cases and the lactic acid cases suggests that both can achieve the target of <\$1/pound, and using the chemical approach we are pursuing on lactic acid, we can achieve nearly 100% yield of acrylic acid as well.

In terms of the SOT for strain development, we note that we have achieved >100 g/L at >3 g/L/hour and near-theoretical yield of lactic acid from biomass hydrolysate using a natural thermophilic strain. We think that this offers us a rapid way to meet Phase I targets and to scale up the process in Phase II.

ENGINEERING THERMOPHILES TO PRODUCE DROP-IN FUELS FROM SYNGAS

(WBS#: 2.3.4.204)

Project Description

Conversion of renewable feedstocks to bioproducts is limited by the heterogeneous and recalcitrant nature of the feedstocks. Multiple-step preparation of biomass for microbial conversion increases cost, complexity, and waste. An alternative is converting biomass to syngas, a more homogenous carbon monoxide (CO) and H₂ output that can be consumed by microbes. The use of syngas as a microbial feedstock represents a new combination of technologies for BETO's Annual and Multi-Year Program Plans, where the use of syngas as a feedstock is currently limited to chemical fuel synthesis. The biological conversion of gasified biomass into fuels is limited by the lack of robust syngas-utilizing microbes

Recipient:	Kiverdi
Principal Investigator:	Dr. George Rudenko
Project Dates:	10/1/2015–9/30/2017
Project Category:	Ongoing
Project Type:	FY 2013—Incubator: DE-FOA-0000974
Total DOE Funding:	\$886,322

amenable to genetic engineering and tolerant of syngas impurities.

To address these issues, Kiverdi and NREL are jointly developing genetic tools and fermentation technologies to produce terpenes in thermophilic syngas-consuming microbes. Foremost, we are establishing basic and essential genetic engineering capabilities for transformation, selection, stable plasmid-based gene expression, and gene knock-outs, building new capabilities from previous advances in these fields. We aim to demonstrate the applicability of a microbial system for fuel synthesis by producing limonene, a next-generation

Weighted Project Score: 6.0

Weighting: For ongoing projects, there is equal weighting across all four evaluation criteria: Approach, Relevance, Accomplishments and Progress, and Future Work.

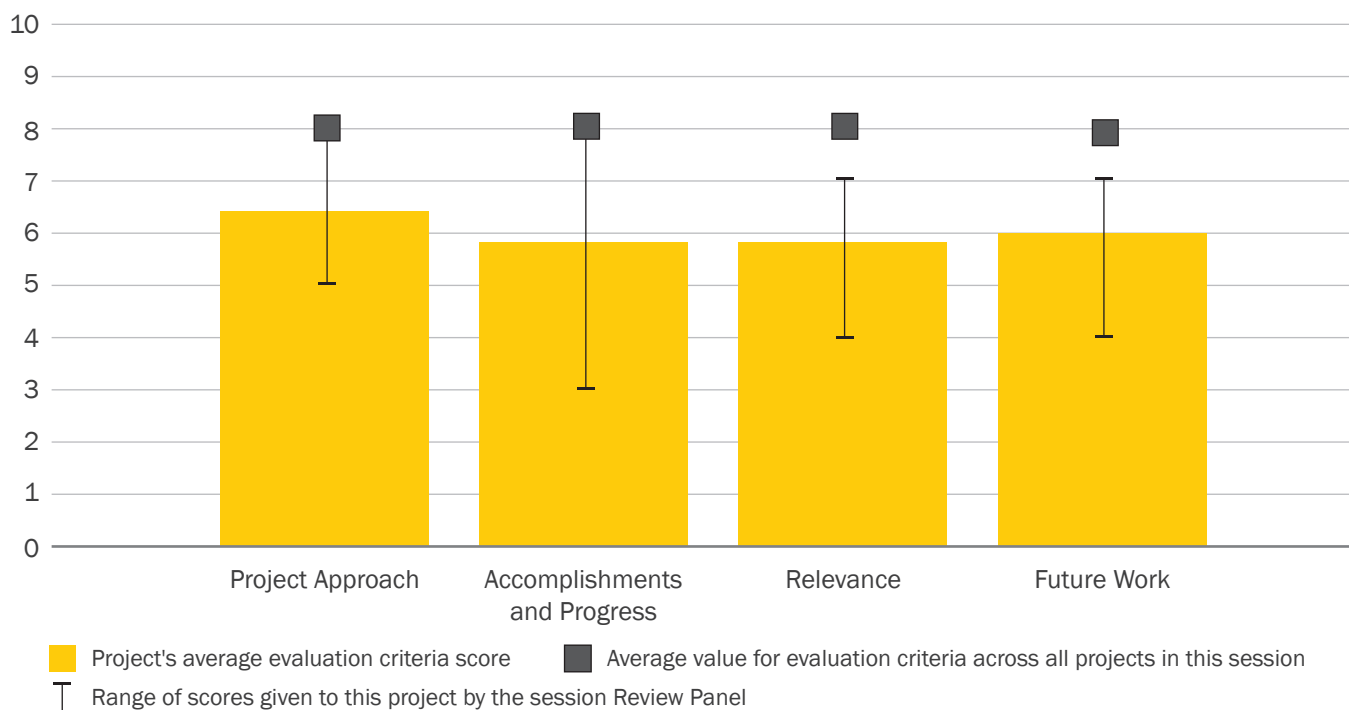

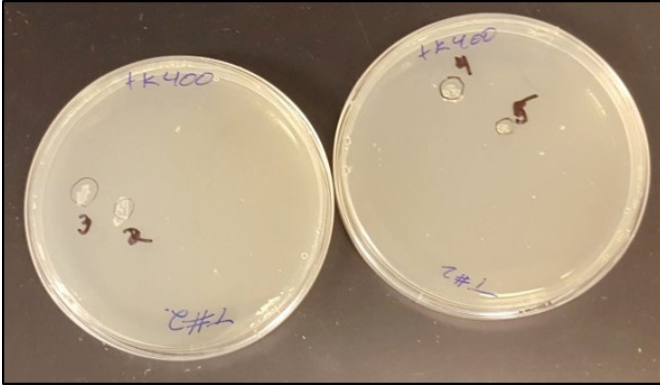

terpenoid biofuel, through the heterologous expression of thermostable enzymes.

Overall Impressions

- The project was hugely ambitious: selecting a new class of potential fuel molecules; starting from the point of screening for a new thermophilic chassis organism; requiring a plant enzyme to work at relatively high temperatures in a bacterium; needing to develop genetic methods; working in an anaerobic system. For a metabolic engineering project in this timeframe, this represents a massive challenge.

The question is going to be how far can the project team get in the remaining 6 months, and what can be proven out to support further investment? A good-quality TEA would be crucial to demonstrate the benefit of producing this type of product in a thermophilic host, particularly on the product recovery side. Demonstration of targeted integration of a marker in the genome would be good to show that gene deletions can be made effectively.

Given so many moving pieces and critical tests to complete, I would highly recommend looking at the project management tools being used. It did not come through strongly in the presentation that this was a central part of the project.

- The PIs have successfully evaluated a number of thermophiles and developed genetic tools that have resulted in a thermophile that incorporates ther-

motolerant enzymes for the eventual production of terpenes. However, the project also needs to evaluate the necessary syngas specification, determine productivity, and evaluate costs of the terpenes as a function of syngas composition, whether gas shift will be needed and the amount of fuel that can be reasonably produced by this route.

- Various groups are looking at engineering syngas-utilizing organisms and have made some progress. This team is taking a slightly different approach, using thermophilic organisms instead of the standard set of CO/H₂ utilizers used in most research. Although high temperature could offer some advantages, it is not clear that these advantages outweigh the ability to leverage previous work for better-characterized organisms. Similarly, how do the economics of terpene production compare to making alcohols, and does it merit the additional work required? Otherwise, the team has made good progress on goals but is still a long way from commercialization.
- This project aims to convert syngas to monoterpenes in thermophilic anaerobic continuous fermentations. Each of these aspects has challenges, and the project has had numerous false starts in strain selection. Original and revised goals are not defined. It is a nice concept and worthwhile to develop such a strain for the future. There is a long way to go to demonstrate it in a process.
- The project team, despite the many challenges, managed to sort a few pieces (e.g., strain, expression tools, etc.). The project, in my mind could, have started differently as more of an exploratory work to vet some of the underlying assumptions under Kiverdi and/or NREL through laboratory-directed R&D. The many challenges appeared unrealistic to overcome, and BETO should consider analyzing the technical and economic feasibility of such projects more rigorously in the future.

PI Response to Reviewer Comments

- We appreciate that the reviewers recognize the ambitious nature of this project; we are likewise aware of this fact. Given this, we have focused efforts almost entirely on moving the research forward as effectively as possible. This focus was reflected in the Peer Review presentation, which was almost entirely focused on the scientific accomplishments, while the TEA and management plans were sparsely addressed. We appreciate this feedback and have responded to these comments by accelerating efforts to complete the TEA at NREL and hiring a “VP of operations” at Kiverdi to formalize and integrate the use of appropriate management tools.

We are aware of efforts on other fronts to engineer CO/H₂-utilizing microbes and agree that following on that work could be a reasonable course of action. We originally decided to pursue anaerobic chemoautotrophic thermophiles because long-term continuous fermentation on industrial scales is very susceptible to contamination. Such contaminations significantly impact the economics of any bioprocess, from yogurt and cheese manufacture to pharmaceuticals. We hypothesized that the selective pressures associated with thermophilic and chemoautotrophic growth would permit longer-term fermentation runs and significantly reduce batch losses and production costs, thereby improving the economics relative to mesophilic approaches. An argument can be made that these advantages do not “merit the additional work”; however, this has yet to be formally considered and tested, and therefore, we proposed to initiate the work needed to test these ideas.

We focused on monoterpenes as a product because they command a higher price (on a per-weight

basis) than the short-chain alcohols produced by the more standard CO/H₂ strains. It is thought these higher-value, near-term commercial applications can help finance future development of the strain and process beyond the BETO project, in order to reach the performance levels and scale ultimately required for fuel production. This general strategy of focusing on fuel molecules with higher-value, near-term chemical applications has been adopted widely in the space. Additionally, as a fuel, the monoterpenes have a number of superior characteristics compared to short-chain alcohols. Since they are middle distillate hydrocarbons, without oxygen, they have significantly higher energy density and specific energy than short-chain alcohols. The chemical characteristics of monoterpenes also offer greater potential in jet fuel applications than alcohols. The PI disagrees with the view that this project supports more rigorous project vetting. Understandably, funding agencies want to have an investment portfolio with maximal returns. However, if projects are judged entirely on alignment with previous work, ongoing work, and “assured” commercialization in the term of a 2-year project, much is lost. I encourage BETO and other federal funding agencies to continue to resist the temptation to only fund the most conservative projects and continue to support out-of-the-box thinking and research. Innovation and a diverse research portfolio cross-pollinate thinking and lines of investigation, and it is my view that this kind of diversity fosters creative solutions and true innovation regardless of the current metrics for “success.”

We appreciate the reviewers’ time and effort to consider our project and would respond positively if further feedback was requested.

DEVELOPMENT OF A SUSTAINABLE GREEN CHEMISTRY PLATFORM FOR PRODUCTION OF ACETONE AND DOWNSTREAM DROP-IN FUEL AND COMMODITY PRODUCTS DIRECTLY FROM BIOMASS SYNGAS VIA A NOVEL ENERGY-CONSERVING ROUTE IN ENGINEERED ACETOGENIC BACTERIA

(WBS#: 2.3.4.205)

Project Description

LanzaTech and Oak Ridge National Laboratory are developing and scaling up a process to sustainably produce acetone and downstream drop-in fuel and commodity products directly from biomass syngas via a novel energy-conserving route in engineered acetogenic bacteria. This offers a safer and more environmentally friendly production method for acetone than the current

Recipient:	LanzaTech Inc.
Principal Investigator:	Sarah Ye
Project Dates:	10/1/2016–9/30/2018
Project Category:	New
Project Type:	FY 2014—Incubator II: DE-FOA-0001320
Total DOE Funding:	\$1,441,115

phenol-dependent method, and the product will have significantly lower greenhouse gas emissions.

The developed process offers a cost-competitive route to acetone and enables biofuels at or below DOE's \$3/gge target. In addition, it also provides an attractive biological alternative to traditional sugar-based acetone-butanol-ethanol fermentation by enabling utilization of non-food biomass resources as fermentation feedstocks. Challenges include the following: (1) Acetate as a byproduct reduces yield and stability. We addressed this by developing a synthetic acetate-independent pathway. (2) A synthetic pathway requires improvements in efficiency. The project is developing a screen to select more-efficient enzyme variants. By month 12, we will

Weighted Project Score: 8.1

Weighting: Approach–25%; Relevance–25%; Future Work–50%.

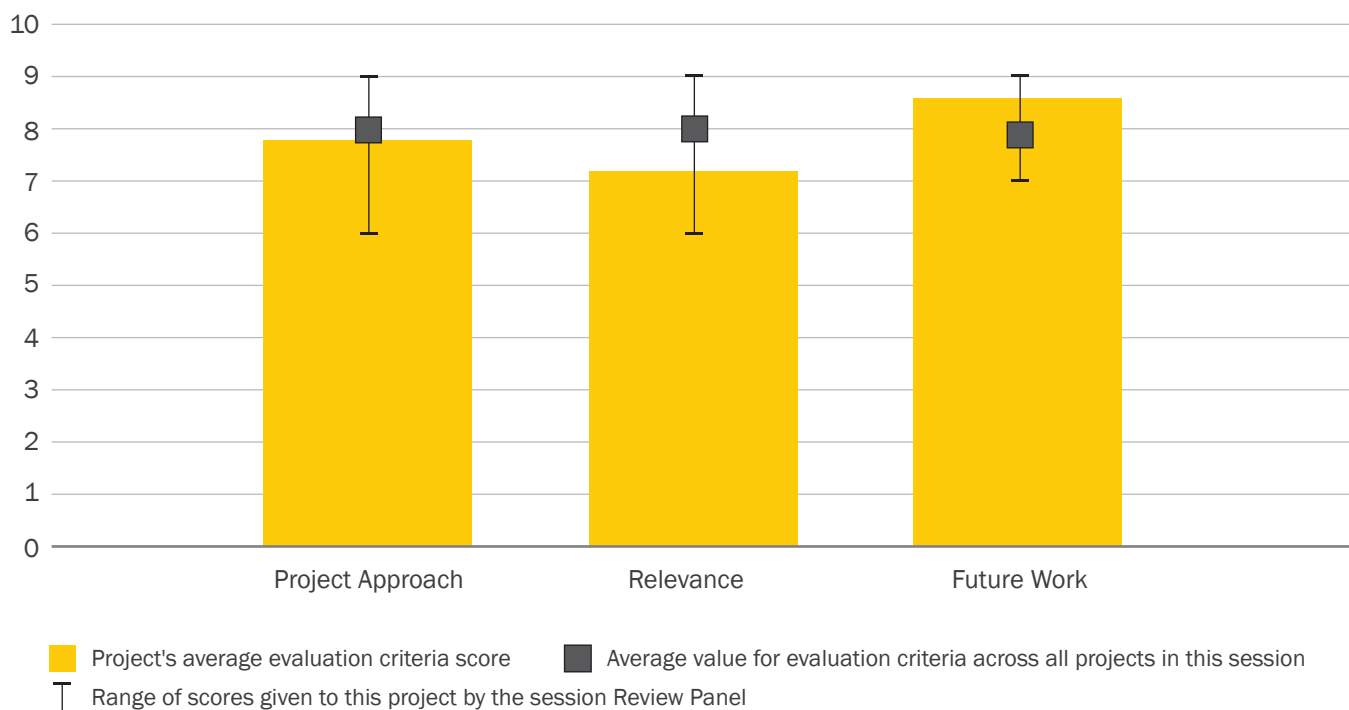
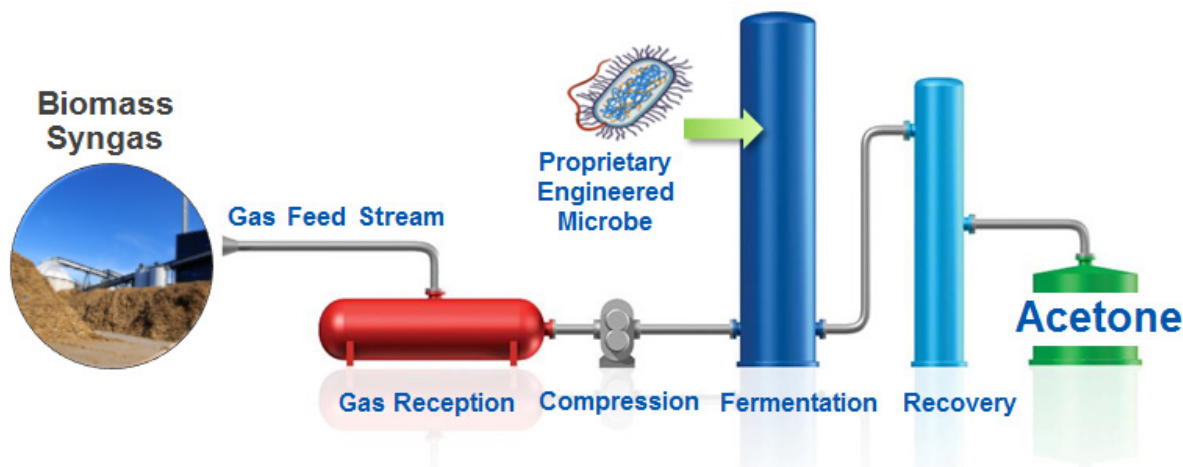

Photo Courtesy of LanzaTech Inc.



demonstrate fermentation stability for acetone production for 7 days at 50% of the commercial rate and 35% of commercial titer. By month 24 (project end), we will demonstrate stable acetone production at a commercially viable rate and titer for 4-day stable production in a scalable reactor.

Overall Impressions

- The project looks to be very well-structured and organized on a project management basis. The tasks look to be well within the technical capability of LanzaTech; they build on LanzaTech's internal technology development efforts and what seems to be a long-term collaboration with Oak Ridge National Laboratory.

The technical approach looks sound, removing competing pathways for the flow of carbon to acetone and expression of a novel pathway that would favor growth by production of adenosine triphosphate.

More information on the market potential for acetone would have been useful (explanation for future drop-in phenol production). Otherwise, production of a molecule that has existing routes to fuels, in particular, from a wide range of biomass feedstocks via syngas looks to be in alignment with BETO goals.

- The project has assembled a nice array of tools and methodologies to address the problem, but it would

greatly benefit from a much clearer presentation of the potential cost of acetone through this process. It's a commodity and must compete on cost. If this process has a much higher cost, then it will ultimately be noncompetitive in the chemical market.

- LanzaTech is developing a *Clostridium* strain for conversion of syngas to acetone. They have a lot of experience engineering these strains and developing gas fermentation processes, so the chance of success is high. However, it is not clear how acetone production will be profitable, regardless of technical success, since it is available at very low cost as a byproduct of the petrochemical industry. More market intelligence should be gathered, and then a thorough TEA performed.
- This project has the potential to replace acetone production (which is declining while demand is increasing) from petroleum-derived phenol and significantly reduce greenhouse gas emissions. Two pathways are being developed in parallel, one with much greater yield potential than the other. TEA might help to focus the work if only one path is economically viable.
- The project is well-structured and building upon a good long-term relationship between Oak Ridge National Laboratory and LanzaTech. The novelty of increasing flux to acetone through a unique metabolic pathway will enable, if successful, higher flux and

a more sustainable production process of acetone. The business case for “green” acetone is questionable, and the project team and BETO are advised to rigorously evaluate the merit of this product.

PI Response to Reviewer Comments

- The demand for acetone in the U.S., European, and Asian markets is estimated at 6.4 million tons per year and is valued at \$7 billion per annum. Acetone is also a direct precursor of valuable downstream products, such as direct drop-in fuels, fuel additives, polymers, and important chemical building blocks. In addition to its direct use, acetone can serve as a platform intermediate for conversion to a number of downstream products, including propylene (\$125 billion), isobutylene (\$25 billion), bisphenol A (\$10

billion), poly(methyl methacrylate) (a fast-growing \$7 billion market), and drop-in fuel isooctane, further diversifying the utility of renewable acetone as a co-product.

The wide range of uses for acetone, in conjunction with the increasing average market price (the 2016 price was roughly 50% higher than 2015), will help offset the effective cost of the fuel product, thus enabling us to meet the \$3/gge target set forth.

LanzaTech has developed detailed techno-economic models that we use to consistently evaluate the economics of our process. Acetone as co-product can enable ethanol fuel production with a target price of \$3/gge. Per this TEA analysis, a 1:1 acetone to ethanol ratio enables meeting this \$3/gge fuel target.

BIO-SYNGAS TO FATTY ALCOHOLS AS A PATHWAY TO FUELS

(WBS#: 2.3.4.207)

Project Description

The Dow Chemical Company is developing a process for the bioconversion of biomass-derived syngas to fatty alcohols as a pathway to biofuels. The fermentation of bio-syngas from lignocellulosic biomass will decouple the biofuel supply chain from the food chain. The production of intermediate fatty alcohols offers a unique opportunity to traverse the “valley of death” for biofuel process and infrastructure development by leveraging the robust chemical markets and high-margin applications of fatty alcohols and their derivatives.

Previous laboratory experiments validated that enzymatic pathways developed within Dow produced fatty alcohols by syngas fermentation within LanzaTech’s *Clostridium* and demonstrated bottlenecks limiting overall alcohol yield. In the proposed research, we’ll deploy

Recipient:	Dow
Principal Investigator:	Devon Rosenfeld
Project Dates:	10/1/2016–12/31/2018
Project Category:	New
Project Type:	FY 2016–MEGA-BIO
Total DOE Funding:	\$1,988,690

the syngas fermentation and strain engineering expertise of LanzaTech, computational modeling capabilities of Northwestern University, and process development expertise of Dow to remove bottlenecks discovered in the previously developed metabolic pathway—maximizing the production of C6–C14 alcohols and devising means to purify the products for channeling into the chemical derivative and fuel markets. This process will change the paradigm for biofuels production, enabling the sale of biofuel for <\$3/gge while vastly improving sustainability.

Overall Impressions

- Overall, this looks like a worthwhile effort to further improve a syngas-to-fatty alcohols process across

Weighted Project Score: 8.1

Weighting: Approach–25%; Relevance–25%; Future Work–50%.

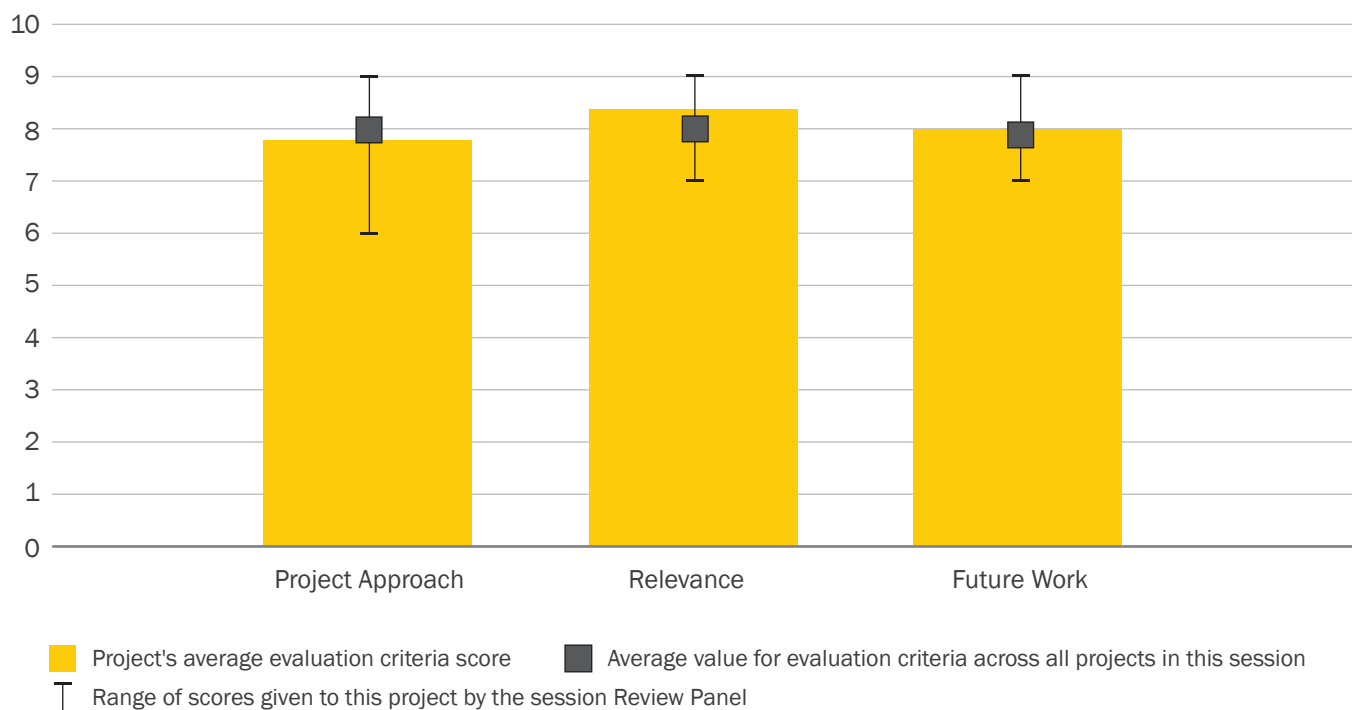

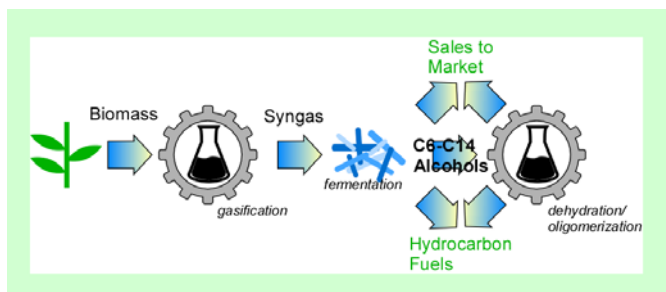

several technical aspects and drive down costs. Some further explanation of the economics and markets for intermediate fatty alcohols (C6–C14) and a broader view of the technical challenges and risks in the project would have been helpful.

- This is a very early-stage project with no results yet. The overall plan seems reasonable, but the team will need to show the effect of syngas composition and source on the ability to make lipids.
- The project aims to convert syngas to C6–C14 fatty alcohols, which are existing chemical products and can be converted to fuels. If successful, this could be a breakthrough technology that could contribute significantly to the MYPP goals. This is a very challenging strain engineering effort, but if successful, the experience of the two partners positions them well for commercialization. The team may be underestimating the challenge of identifying enzymes that work preferentially on longer-chain-length compounds. They are leveraging Northwestern’s computational methods to identify target enzymes, but predicting substrate range and specificity is unreliable. So, many enzymes should be screened, and the need for enzyme engineering should be anticipated.
- This is a challenging metabolic engineering project that has gotten off to a good start due to the unique expertise of each of the partners. This will be a fun project to watch in coming years. Product markets are well-understood and accessible by the lead partner.
- The project is well-aligned with BETO’s ME-GA-BIO FOA and, if successful, will provide confidence at Dow and LanzaTech to continue harness-

ing the findings. I advise the team to boost the key performance indicators of the project, as achieving 100 mg/L at 4 mg/L/hour in 2 years between very experienced teams at LanzaTech and Dow is low-balling a milestone. I would encourage the team to offer a higher bar after year one if successful.

PI Response to Reviewer Comments

- The economics of our process are confidential; however, we have process and techno-economic models that we will use to consistently evaluate the economics of our process. Our target molecules, C6–C14 straight-chain, terminal alcohols, have widespread consumer chemicals applications, including use in detergents and soaps, personal care and cosmetics, plasticizers, corrosion inhibitors, and lubricating fluids. Our target alcohols are a significant part of the global fatty alcohols market where 2014 demand surpassed 2,300 kilotons in 2014 (\$3.5 billion).

This market is projected to grow by 5.1% annually to approach \$5.5 billion in 2023. The market outlets for our target alcohols will enable our ultimate aim of biofuel production by supporting infrastructure development to traverse the “valley of death.” Ethanol made by this process will be converted to jet fuel. The end goal is both to sell the fatty alcohols for high-margin chemicals applications and to channel them into the fuels market as both diesel blendstock and as diesel/jet fuel after hydroprocessing or direct enzyme-mediated conversion. The technical challenges are the strain and enzyme engineering to mitigate bottlenecks and promiscuous pathways.

The project titer and productivity targets are significantly higher than what we presented during the Project Peer Review meeting. These targets remain confidential and were created using the state of our technology upon submission of our proposal and application of techno-economic models.

BENCH SCALE INTEGRATION

(WBS#: 2.4.1.100)

Project Description

The Bench Scale Integration project develops bench-scale integrated biomass-to-fuel conversion processes for pilot-scale demonstration to meet BETO's \$3/gge 2022 fuel cost target. The project focuses on improving YRT from the enzymatic hydrolysis and fermentation process steps. Outcomes include successfully demonstrating a bench-scale process meeting the necessary criteria to reduce the risk of scaling; generating data for NREL's annual SOT reports, which track research progress and cost improvements; and validating new technology when possible. Bench-Scale Integration focused the last 2 years on using fermentation science to improve productivity of several processes.

By managing nutrients and moving to a fed-batch process, we doubled lipid fermentation productivity from 0.32 g/L/hour to 0.68 g/L/hour. For 2-3 butanediol pro-

Recipient:	National Renewable Energy Laboratory
Principal Investigator:	Nancy Dowe
Project Dates:	10/1/2015–9/30/2018
Project Category:	Ongoing
Project Type:	AOP
DOE Funding FY 2014:	\$0
DOE Funding FY 2015:	\$1,000,000
DOE Funding FY 2016:	\$1,000,000
DOE Funding FY 2017:	\$1,000,000

duction, optimizing aeration levels in fermentation vessels doubled the titers from 10 g/L in shake flasks to 20 g/L in fermenters. In addition to fermentation research, the project team worked with three commercial enzyme companies to test two of NREL's pretreated feedstocks using an enzymatic hydrolysis assay: deacetylated dilute acid and deacetylated mechanical refined corn stover. One of the enzymes produced 85% glucose yield from deacetylated dilute acid at 10 mg protein loading, reducing the loading in half. Taking the improvements in lipid productivity and enzyme reduction, we showed a \$1.8/gge decrease in the MFSP for FY 2016.

Weighted Project Score: 8.5

Weighting: For ongoing projects, there is equal weighting across all four evaluation criteria: Approach, Relevance, Accomplishments and Progress, and Future Work.

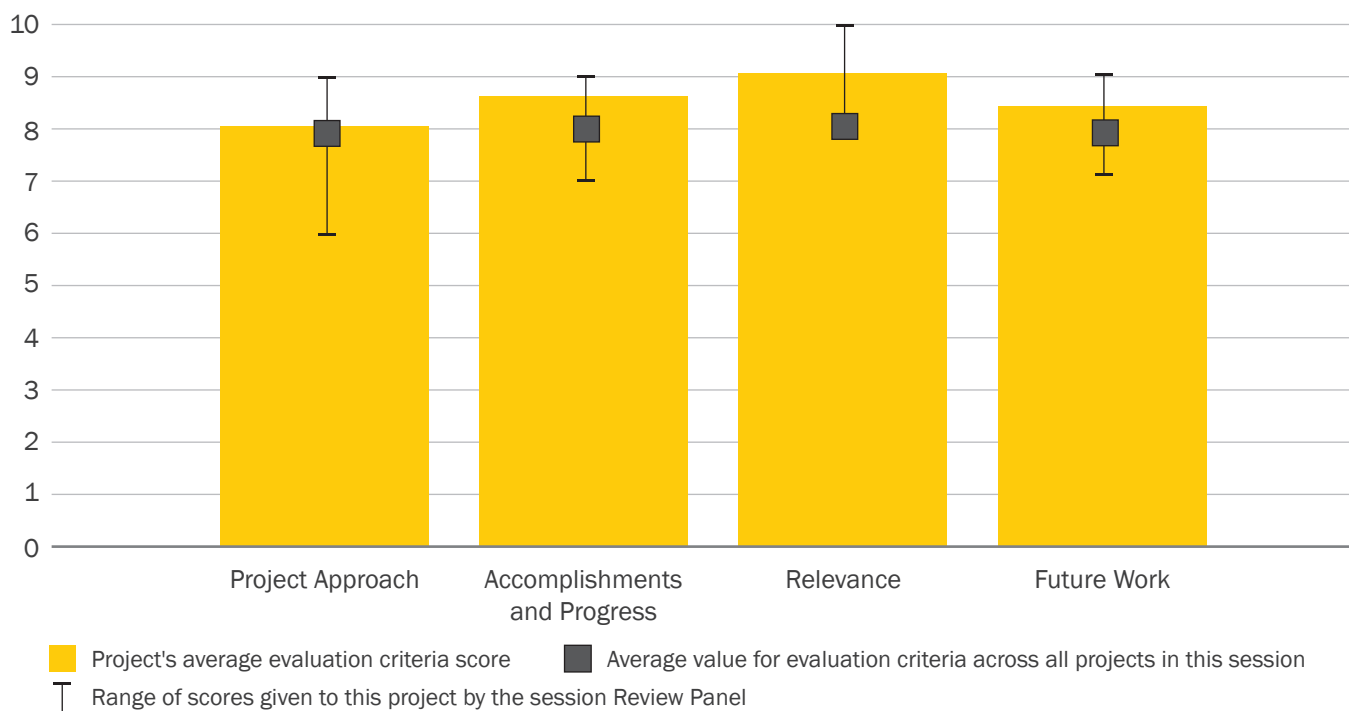



Overall Impressions

- The project is a key component for the NREL program and looks to be well-run. There are obviously a lot of moving pieces in bringing together different technologies and processes, but it certainly looks under control. Processes obviously get expensive at larger scale, and fewer tanks will be available, so it is essential to have a platform that allows multiple replicates to be performed across multiple conditions. It would have been good, actually, to get a quick table of how many vessels are available for the team and at what working volume.

The project has several functions: optimizing process conditions to get the best out of the material being developed by other projects in the NREL program; comparing the materials being generated (e.g., deacetylated dilute acid vs. deacetylated mechanical refined pre-treated material); and helping industry directly by benchmarking material, such as enzyme packages. In this regard, NREL can fulfill an important role—many companies go along a particular technical route, particularly with pre-treatment regimes, so NREL can really help in showing how these compare to each other.

- The bench-scale operations provide a critical element to addressing BETO's goals of getting laboratory-scale technology into the marketplace. By providing an intermediate step between the laboratory and the pilot unit, potential problems in scale-up can be worked out prior to large investments in

pilot operations. Since this is a service function of the program, it is likely more difficult to establish milestones against which progress can be measured. Further, its integration and collaboration with the ABPDU and other scale-up operations in the program could be more clearly defined. However, this is an important component of the BETO program that needs to receive continuing support as a service function.

- The Bench-Scale Integration program provides a bridge between shake flask and pilot scale, and it serves as the next step following organism development. The team has demonstrated significant improvement in SOT for succinate, 2,3-butanediol, and lipids, and it has made improvements to the facility (e.g., online mass-spec for off gas analysis) that improve the quality and value of the data produced. In the future, the team should strive to be even more interactive with the strain development team and work with them to develop a small-scale model that can accurately represent aeration conditions in the fermenter. Since the strains are sensitive to aeration, such a tool may help optimize conditions and select the most robust strain prior to fermentation testing.
- This project is an indispensable resource for testing new bioconversion process designs, improving TRY through fermentation optimization, tracking progress, updating SOTs, and providing data for TEAs. This project interacts with many NREL projects and bridges the gap between shake flask results and pilot-scale validation, supporting NREL bioconversion projects and industrial partners.
- This is a good project with a clear outline of the challenges and opportunities and good plan to mitigate them. This project, like other service-based ones, should be evaluated differently—perhaps together with the other service-based projects for a 5-year plan or longer on how they enable the BETO's mission and vision.

PI Response to Reviewer Comments

We thank the reviewers for their positive comments and appreciate their acknowledgement of the importance of Bench-Scale Integration's role in developing biofuel fermentation processes at bench scale to facilitate scale up to the pilot plant. We recognize the importance of working closely with the strain development groups to evaluate strains in process-relevant conditions and providing important feedback on strain performance.

The project is closely aligned with pretreatment, pilot-scale integration, analysis, and separations projects where we share data on pretreated feedstock evaluations, share performance data for techno-economic

modeling and SOT reports, provide feedback to the separations project on biomass sugar quality, produce material for downstream processing, and develop robust fermentation processes for pilot plant scale-up.

We also maintain a close association with industry by providing information on biocatalyst performance in a process context, which we hope will aid in scale-up. For future work, we agree with the reviewers that we should develop a small-scale aeration model and plan to work with our strain development and process simulation projects to accomplish that task. It would be prudent for this project to leverage other DOE facilities like the ABPDU in our development work.

SEPARATIONS DEVELOPMENT AND APPLICATION

(WBS#:2.4.1.101)

Project Description

The Separations Development and Application project performs separations R&D to improve the efficiency and economics of producing and recovering biofuels from biomass. It supports BETO's 2022 \$3/gge production cost goal and aligns with BETO's MYPP strategic and performance objectives to produce advanced biofuels from biomass sugars (and other carbohydrate and lignin derivatives).

The separations the team is researching, developing, and improving include upstream solid-liquid separations and hydrolysate liquor concentration to prepare biomass sugar streams for biological upgrading, as well as further cleanup of such hydrolysates to prepare them for catalytic upgrading, and also downstream recovery of an intracellular lipid product (fuel precursor) produced from the sugar stream. The project also advances devel-

Recipient:	National Renewable Energy Laboratory
Principal Investigator:	Jim McMillan
Project Dates:	10/1/2015-9/30/2018
Project Category:	Ongoing
Project Type:	AOP
DOE Funding FY 2014:	\$0
DOE Funding FY 2015:	\$750,000
DOE Funding FY 2016:	\$750,000
DOE Funding FY 2017:	\$750,000

opment of continuous enzymatic hydrolysis technology, which offers significant cost-reduction potential over batch processing if it can be robustly demonstrated.

The project's scope and schedule are driven by the need to identify and establish integrated process(es) to be pilot demonstrated at NREL in FY 2022, which requires major process elements (including integral separations) to be defined and ready for piloting by the end of FY 2019. We have been using and will continue to use TEA informed by performance data from this project to guide and refine R&D directions/priorities.

Weighted Project Score: 8.3

Weighting: For ongoing projects, there is equal weighting across all four evaluation criteria: Approach, Relevance, Accomplishments and Progress, and Future Work.

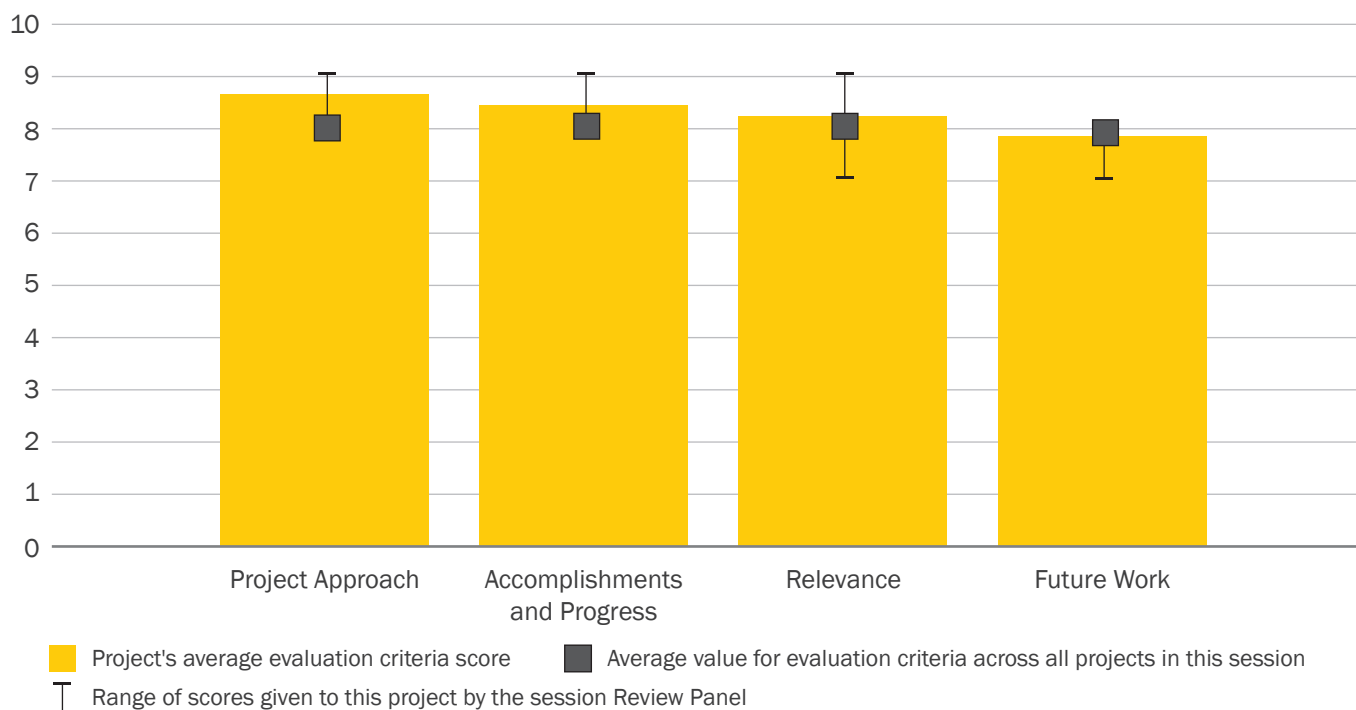

Overall Impressions

- Overall, the project just looks really well-run and logically organized, while providing both basic studies and innovative approaches. The technical area is one that can have a significant impact on costs and also provides a technical route that can enable other parts of the process to either work better or be more economic. Indeed, it is possible that some of these solutions (product recovery, recycling of enzymes) can take some pressure off areas of biology and reduce the need to reach very high performance targets (e.g., product tolerance or very low enzyme loading levels) that would otherwise be required to make a process economic. The approach on several of the topics is very helpful, in taking a wide view of the possible solutions (e.g., the seven basic methods tested first for the yeast cell lysis task) and then down-selecting to the best for further optimization.

As a side note, this is probably the best-organized and clearest presentation in the 2017 Project Peer Review.

- This project described success in several different separation processes directly applicable to BETO programs. Further, the work was closely and clearly linked to potential cost reductions important for meeting the 2022 BETO milestone. This is an effort worth continuing, as separations will remain a significant cost contributor within the biorefinery. As the project goes forward, better coordination with the Separations Consortium will be expected.
- This program aims to address two of the most-costly separations processes in biological conversion. The relevance to the MYPP cost targets is clear, as separation conditions directly impact the process cost. The project has clearly established targets and has come most of the way towards reaching them through a combination of novel methods and classical process optimization. The main challenge

not addressed here is how well the processes scale from the laboratory to the pilot/commercial scale. In addition, due to the “moving target” nature of the project with uncertainty in upstream composition, further optimization may not be fruitful. Instead, spend the effort on novel technologies that could provide a step change.

- Low-cost, efficient separations are one key to bringing down the cost of biofuels and bioproducts, and this team is addressing critical issues. Some false starts are inevitable when processes and unit operations are developing in parallel (e.g., incompatibility of flocculation with lignin upgrading). This project is working with algal R&D to take advantage of cell lysis advances and adapt separations accordingly. Continuous enzymatic hydrolysis is a nice demonstration, and I'll be watching as insoluble solids increase (>10% insoluble solids and alternate membrane technologies are tested for enzyme passage. This is nice work and should benefit from the Separations Consortium in the long run, and vice versa.
- The project history and relevance to BETO's mission is clear, and the technical and management approaches are sound. The need for good separation technologies to aid in the cost cutting of hydrocarbon fuels is a must, and the team is well-equipped to contribute to it. The good relationship and cross talk with the separation group and industry knowhow will be mandatory to future success. The team has great initiative and competency to build upon.

PI Response to Reviewer Comments

- The reviewers' constructive comments and recommendations are appreciated. As noted, regardless of which specific fuel pathway is down selected for further development in the biochemical platform, separations will continue to be an important cost factor in integrated biorefining. As the project goes forward, coordination with the nascent Separations Consortium will need to increase, and this is planned.

Similarly, we need to maintain/grow our interactions and collaborations with industry, and we plan to do this in close collaboration with the Biochemical Conversion Platform's Pilot-Scale Integration project, which has responsibility for demonstrating pilot scale-up/integration of separations technology solutions developed by the Separations Development and Applications project.

In all cases, this project focuses on developing separations solutions that will be both cost-effective and scalable. Nonetheless, there are ongoing challenges to identifying and acquiring suitability flexible bench- and pilot-scale systems for all separation processes being researched, and this further demonstrates why the Separations Development and Applications project must continue to coordinate its equipment selection activities closely with the Pilot-Scale Integration project.

These challenges notwithstanding, we agree that there is a “moving target” issue in developing separations processes to recover intermediates or products for which the production processes themselves are still under development, and that, as a result, further optimization of identified separations methods (like those to recover intracellular lipids) will not be that informative until further production technology down-select has occurred. Consequently, going forward, this project will strive to avoid further separations process optimization in favor of focusing on development of novel technologies, such as continuous enzymatic hydrolysis, that have the potential to lead to a step change in overall production cost.

BIOCHEMICAL PROCESS PILOT-SCALE INTEGRATION

(WBS#: 2.4.1.102)

Project Description

The Biochemical Process Pilot-Scale Integration project's high-level goal is to take technology developed at the bench scale and demonstrate its performance at pilot scale, producing data for TEA meeting BETO's 2022 biofuel cost target. To facilitate the work, we maintain the functionality and operational readiness of the biochemical pilot plant located at NREL, and we evolve its capability to perform process-relevant integration work for BETO and industrial clients. We also solve critical scale-up issues that usually only manifest at pilot scale prior to technology deployment. However, processing biomass feedstocks remains a challenge at pilot scale, particularly handling a variety of raw biomass materials.

In the past 2 years, we acquired a rotary drum filter and disk stack centrifuge for process development efforts.

Recipient:	National Renewable Energy Laboratory
Principal Investigator:	Dan Schell
Project Dates:	10/1/2003–9/30/2018
Project Category:	Ongoing
Project Type:	AOP
DOE Funding FY 2014:	\$2,000,000
DOE Funding FY 2015:	\$2,000,000
DOE Funding FY 2016:	\$2,000,000
DOE Funding FY 2017:	\$2,000,000

We measured the residence time distribution in a continuous pretreatment reactor and showed that pretreatment severity has little effect on the residence time distribution. We found that separating liquor from alkaline-pretreated material is difficult. We also assessed the ability to predict pretreatment results in large-scale reactors from small-reactor system data. Finally, we generated more accurate performance and cost information for processes requiring aeration using either stirred tank or bubble column reactors. The pilot plant continues to be used by industrial clients, and six new industry-based projects began in FY 2015/2016.

Weighted Project Score: 7.9

Weighting: For ongoing projects, there is equal weighting across all four evaluation criteria: Approach, Relevance, Accomplishments and Progress, and Future Work.

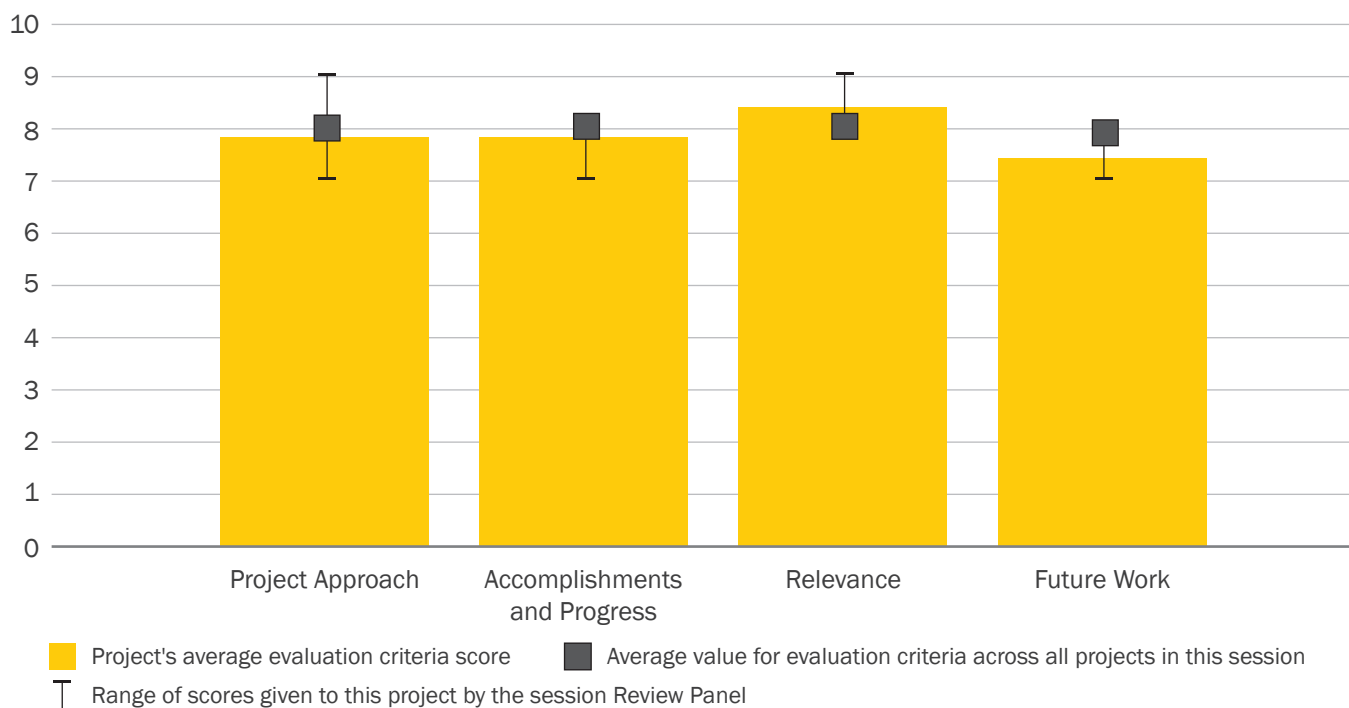



Overall Impressions

- Overall, the pilot plant operations look to be fulfilling an essential function for both the internal needs of the NREL projects and external stakeholders. This scale is obviously an essential step for companies to go through to validate technologies and identify potential roadblocks, but it is an expensive proposition. Having a single facility that can cover a range of unit operations, processes, and configurations that may have a significant effect on the performance of biological systems under development at companies makes a lot of sense economically. This is a perfect example of how a national laboratory can fulfill an important role in lowering development costs and risks for industry and allow industry to cast a wider net than they would be able to on their own.
- The process development unit is an important component and capability to have for a program that is dedicated to eventual industrial use. It is hard to measure progress against goals, as this is another “responsive” activity, like the bench-scale program. However, NREL has designed a facility with equipment relevant for industrial testing, and something that appears to be busy for most of the time.

The presentation and discussion suggested that the process development unit operates in a bit of a

vacuum with regard to other larger-scale capabilities within the program (bench, ABPDU). Going forward, better communication and coordination between these operations would streamline management and would improve industry’s ability to identify the best location for scale-up of their processes.

- The pilot plant is a core capability to BETO that is essential to achieving the ultimate \$3/gge milestone. The team has achieved one of the primary ongoing objectives, which is to keep the plant operational and with the most relevant technology. They have also provided scale-up services to some projects to give valuable guidance on recognizing scale-up problems. It is not clear how the projects are chosen and prioritized. This has to be a programmatic decision, rather than just based on who comes to them with a project. I think this program would benefit from even more funding to ensure that such a critical resource remains high priority. Regardless of the organism used and the products chosen, pilot validation is necessary.
- This facility has been supporting the bioethanol industry for many years. The pilot plant is evolving with the industry, is a valuable resource supporting AOP objectives at NREL, and is also a great resource for external parties. Pilot-scale reactor facilities are fairly rare, and process integration at this scale is necessary to de-risk commercial scale.
- The pilot-scale facility is a must-have step in any scale-up and, as such, is a very important part of BETO’s mission to validate near-demo-scale-ready technologies. The team is specialized and knows their work and used good practices of mixture designs and scale-up/down models to address scale-up issues. The challenge of managing publicly available data is understood. The project has good cross talk with the bench-scale integration and analytics team and works closely with the Separation Consortium. Overall, there is good management and a good technical approach. It is recommended, though, to

integrate a community of pilot plant facility and know-how (APBDU, NREL, SCADA at PNNL, bench-scale validation, and the Separations Consortium and analytics projects) somehow, as they all are continued, needed support functions.

PI Response to Reviewer Comments

- We appreciate the reviewers' comments and their efforts reviewing this project. We will continue to evaluate pilot-scale processing needs and acquire capabilities with BETO's support to make the biochemical pilot plant a relevant facility for industry and BETO to develop and test new hydrocarbon biofuel production technologies. As technology

development continues and process options for pilot-scale verification are identified, we will continue to increase our collaborations with other BETO projects, in particular, the Bench-Scale Integration project. An even closer collaboration is planned between the Bench-Scale Integration project and this project beginning in FY 2020, and indirectly with industrial and academic stakeholders. A capabilities workshop with all BETO facilities performing pilot-scale work, which would include industry representation, might be useful for soliciting recommendations for new equipment and how best to use these various facilities.

TARGETED MICROBIAL DEVELOPMENT

(WBS#: 2.4.3.102)

Project Description

The Targeted Microbial Development project will investigate and recommend promising pathways for advanced biological upgrading of biomass sugars and lignin to hydrocarbons and co-products, supporting the DOE-BETO 2022 goal of enabling advanced hydrocarbon fuels at \$3/gge. By applying metabolic engineering and synthetic biology tools, we are working to engineer microorganisms for efficiently upgrading sugars to hydrocarbon intermediates and valorizing lignin for chemicals production.

Task 1 focuses on engineering *Zymomonas mobilis* to produce a mixed ethanol and 2,3-butanediol (BDO) from sugars, which provides product flexibility for upgrading the BDO intermediate to hydrocarbon fuels or chemicals (e.g., butadiene). Task 2 works on meta-

Recipient:	National Renewable Energy Laboratory
Principal Investigator:	Mike Himmel
Project Dates:	10/1/2015–9/30/2018
Project Category:	Ongoing
Project Type:	AOP
DOE Funding FY 2014:	\$0
DOE Funding FY 2015:	\$1,900,000
DOE Funding FY 2016:	\$1,900,000
DOE Funding FY 2017:	\$1,900,000

bolic engineering of *Pseudomonas putida* to produce muconate from lignin monomers. Task 3 investigates production of long-chain fatty alcohols (as secreted products) as biofuel precursor molecules by engineering oleaginous yeasts. We are also investigating novel CBP concepts that can reduce the cost of producing hydrocarbons.

Overall, Targeted Microbial Development provides leading technologies for producing reduced-cost fuels and high-carbon-efficiency intermediates amenable to separations and catalytic upgrading to hydrocarbon fuels

Weighted Project Score: 7.8

Weighting: For ongoing projects, there is equal weighting across all four evaluation criteria: Approach, Relevance, Accomplishments and Progress, and Future Work.

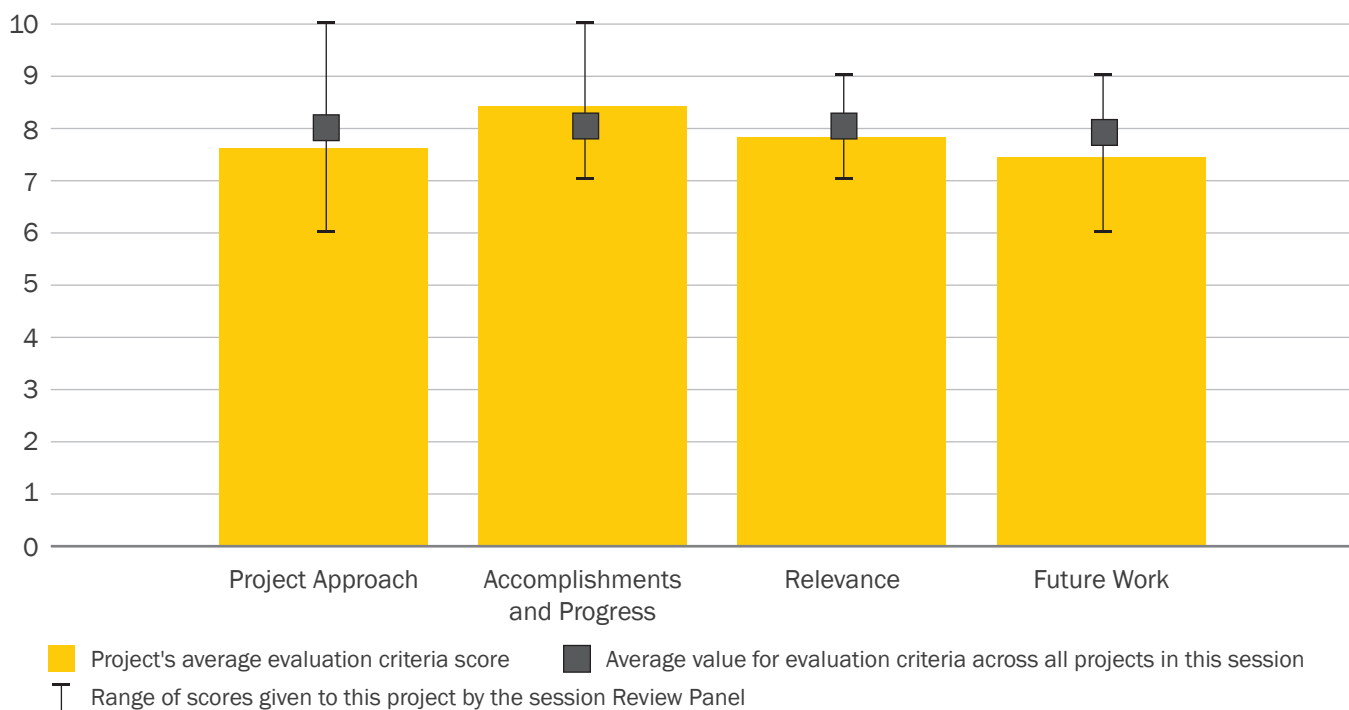

and identifies future sugar upgrading technologies. We also seek to develop a critical knowledge base, enabling BETO and the bioenergy industry to deploy production of third-generation hydrocarbon biofuels from biomass.

Overall Impressions

- The project has identified what seem to be relevant target pathways for co-products in order to improve overall economics. The metabolic engineering strategies selected are generally reasonable and reflect the expertise present at NREL in metabolic engineering. However, in the context of the current SOT with regard to synthetic biology in both industry and academia, the scope of the metabolic engineering strategies laid out here seem very limited. It is hard to think that progress towards both the TRY for each task and the understanding gained would not be faster and a more efficient use of resources with high-throughput strain generation approaches.

Given the complexity of cellulase and hemicellulase mixtures that are known to be required for effective deconstruction of pretreated lignocellulosic material, it is hard to see the study of expression of cellulases in otherwise non-producing hosts as an effective use of resources, given the remaining challenges in pathway engineering for the three metabolic routes.

- One of the NREL strengths is developing a clear understanding of how biochemical systems work and then linking that understanding to processes that meet BETO's strategic direction. This knowledge-based approach is proving itself through the identification of systems that support BETO's goals, for example, the discovery of organisms that can attain nearly theoretical yields of muconate from lignin derivatives. This capability will be critical for current projects and ongoing efforts to engineer organisms that can selectively and rapidly convert both lignin and carbohydrates to high-value products.
- The Targeted Microbial Development program addresses three separate strain engineering projects. All three use different organisms and represent different product/co-product opportunities. The use of *P. putida* to convert lignin monomers to muconic acid is especially exciting, since relatively little work has been published to address this challenge. Progress has been very impressive on all efforts. The use of metabolic models in conjunction with experiments was shown to be essential to this work. However, the challenges that lie ahead may be even greater, and the team should make sure to use all resources available to guide strain and process development. This includes omics analysis, diagnostic experiments to identify bottlenecks, and adaptive evolution to overcome tolerance challenges.
- Three pathways to upgrading or co-products are being pursued in this project. The mixed ethanol/diol product is the most advanced, and BDO titers have dramatically improved with metabolic engineering and fermentation optimization. This is a nice, original, co-product proof of concept. The team has done a good job of recognizing the complexity of the separation and fermentation scale-up, and they are considering their options. Lignin upgrading to fatty alcohols and muconate are successfully demonstrated concepts. They are further from their target titers. Two of the tasks are considering scope changes due to their understanding of the economics and/or robustness of scalability. This project is doing a good job of using TEA to make decisions.
- This is a good team with ambitious targets, which are relevant in aiding and expediting metabolic engineering of various hosts and are aligned with the MYPP goals. The overall TEA of fatty alcohols should be evaluated as this might be too challenging of a target for the oleaginous yeast program. However, thorough benchmarking of progress toward the TEA goal will likely keep things in spec, and the team, together with Hal Alper's collaboration, has the skill set to tackle the technical challenges.

PI Response to Reviewer Comments

- We thank the Review Panel for the supportive comments and helpful feedback. In terms of high-throughput synthetic biology–based strain engineering, we are attempting to actively deploy a rapid genome-scale editing tool in *P. putida* KT2440 currently in collaboration with a world-leading synthetic biology group. In addition, we are leveraging modern systems biology tools (proteomics, transcriptomics, and metabolomics) to identify bottlenecks and adaptive laboratory evolution to improve both exogenous and endogenous pathways. If these approaches are successful, we will be able to very rapidly modify and improve flux through aromatic-catabolic pathways in this robust host.

We are also attempting to deploy in *Zymomonas* a rapid genome-scale editing tool, such as CRISPR, which will enable us to be more efficient in high-throughput strain generation. We are also leveraging modern systems biology tools (proteomics, transcriptomics, and metabolomics) to identify bot-

tlenecks. As explained in the presentation, the CBP work is our lowest TRL effort and is thus treated as exploratory and low priority. Regarding expression of Cel7A cellulases, these proteins are known to be difficult to fold in yeast. We, and others, assume that enzymes from GH families 5, 10, and 11 will be less of a problem. With that said, we agree that there are remaining challenges in pathway engineering for the three metabolic routes.

Thank you for your comments. It is nice to hear that we are doing a good job of using TEA to guide our research. For example, we are working to develop anaerobic pathways, which will scale more effectively than microaerophilic or aerobic fermentations. With guidance from NREL's TEA analysis, we consider 2,3-BDO as precursor to butadiene as an alternative strategy, possibly for products valorization of a fuels production process. Our primary focus is maximizing fuel yields in our base case. In fact, we considered a route that takes both ethanol and BDO to hydrocarbon fuels.

PROCESS INTENSIFICATION FOR THE REDUCED COMMERCIAL CAPITAL EXPENDITURE OF BIOFUELS PRODUCTION USING DYNAMIC METABOLIC CONTROL

(WBS#: 2.4.3.200)

Project Description

This program is aimed at greatly reducing the capital costs for commercial-scale biobased processes by developing semi-continuous fermentations that can achieve unprecedented volumetric fuel production rates. Currently, we estimate these processes can reduce capital requirements with a 5- to 10-fold increase. Our approach is to utilize advanced two-stage technology, leveraging synthetic metabolic valves in the semi-continuous fermentation of farnesene and related terpenes. Synthetic metabolic valves convert growing cells into active, non-growing, stationary-phase biocatalysts,

Recipient:	Duke University
Principal Investigator:	Michael Lynch
Project Dates:	10/1/2016–9/30/2018
Project Category:	New
Project Type:	FY 2014–Incubator II: DE-FOA-0001320
Total DOE Funding:	\$1,691,595

which can be concentrated and recycled, improving volumetric rates. The key performance metrics to be demonstrated include production rates greater than 25 g/L/hour. and final product titers >500 g/L.

Overall Impressions

- The project contains an interesting central idea—genetic control of metabolic pathways that are required for growth but not product formation and, therefore, can be “turned off” after a growth phase. This adds another dimension to standard metabolic engineering strategies, which, to date, largely rely

Weighted Project Score: 7.5

Weighting: Approach–25%; Relevance–25%; Future Work–50%.

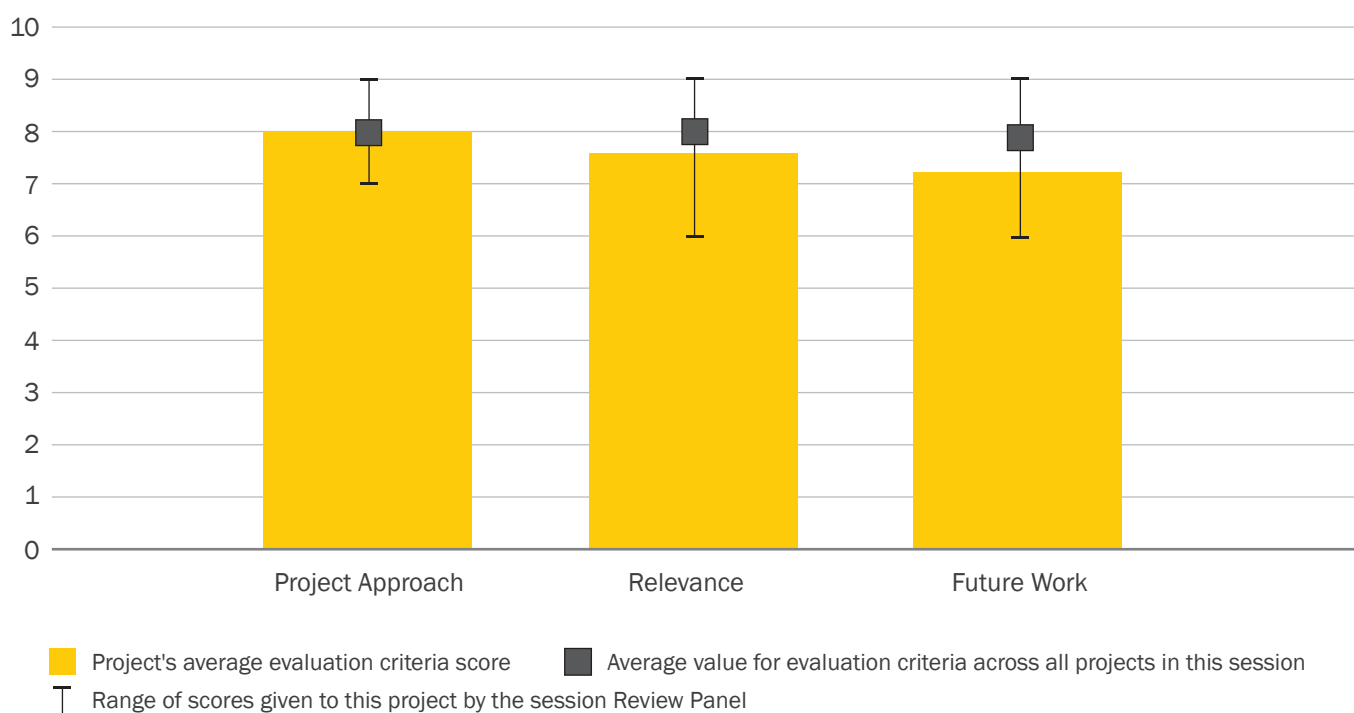

on “fixed” mutations that, for example, seek to permanently eliminate side pathways and are therefore limited to those not essential for growth. The route also has the potential to provide an alternative to fermentation process controls that rely on limitation of a key nutrient to control growth (e.g., phosphate or nitrogen).

What is not clear currently is how the concept will play out when using real-world lignocellulosic sugar streams as the carbon source rather than clean sugar mixtures. Going a long way down the path of genetically optimizing a host strain in relatively benign conditions on clean sugars may create a technical risk, given that the cell physiology required to tolerate toxins in most lignocellulosic hydrolysate streams could be quite different.

The commercial benefits seemed to be tied to intensification of the process—generating a high volumetric productivity by recycling cells and maintaining high biomass concentration during fermentation. This is likely to be a much harder task on lignocellulosic sugar streams than on clean sugars in the laboratory or even sucrose or starch-based sugar streams at scale. It may require separate saccharification of high solids concentrations and then very stringent removal of residual solids. The capital expenditure benefits from the high biomass concentration and continuous operation in this scheme may be offset by more unit operations needed upstream and downstream.

- The PIs are pursuing an interesting biochemical approach for the biorefinery and have established a reasonable initial plan. More detailed evaluation will need to wait until more results are in.
- The goal of this program is to develop a semi-continuous process that can reduce capital requirements significantly. The project leverages technology to switch metabolism from growth to production and maintain production phase indefinitely as the

product is removed. The latter may be specific to a product that can be separated easily so as not to build up to toxic levels and/or stop the reaction due to reaching thermodynamic equilibrium. However, the ability to tune gene expression dynamically can be leveraged for any fermentation configuration. The team at Duke and DMC Limited (Dynamic Metabolic Control) has pioneered this technology and seems to be well-suited to reach the objectives. The main challenges will be around scale-up, which are not specifically addressed in this work: behavior of the metabolic switching in large heterogeneous environments, engineering of the semi-continuous process, and possible contamination during long fermentation runs.

- This is an ambitious project. It is being demonstrated on farnesene production by *E. coli*, but success in this process could lead to similar process intensification approaches for other bioprocesses. The robustness of fermentations utilizing this metabolic control switch will be critical.
- Overall, this is a very ambitious project with a well-structured team that has already demonstrated its ability to rapidly develop strains with high flux to products using its dynamic metabolic control models. This high-risk/high-gain project, if successful, will allow a pipeline of such approaches toward other hydrocarbon fuel molecules from lignocellulosic sugars. The risk factors to take into account are the cost of sugars and the ability to overcome sugar toxicity, as well as the engineering of feeding system to allow the high feed of sugars, dealing with the generated water and product separation. The plan to tackle these risk factors is reasonable, and I’m wishing the project team the best of luck in accomplishing these.

PI Response to Reviewer Comments

- No official response was provided at the time of report publication.

BIOCHEMICAL PROCESS MODELING AND SIMULATION

(WBS#: 2.5.1.100)

Project Description

The Biochemical Process Modeling and Simulation project aims to reduce the cost and time of research by applying theory, modeling, and simulation to the most relevant bottlenecks in the biochemical process. We use molecular modeling, quantum mechanics, metabolic modeling, fluid dynamics, and reaction-diffusion methods in close collaboration with pretreatment, hydrolysis, upgrading, and TEA. The project's outcomes are increased yields and efficiency of the biochemical process, added value to products, and reduced price of fuels by specifically targeting catalytic efficiency, reactor design, enzyme efficiency, and microbial design.

We work closely with experimental projects to identify problems and iterate with experiments to find and

Recipient:	National Renewable Energy Laboratory
Principal Investigator:	Mike Crowley
Project Dates:	10/1/2004-9/30/2018
Project Category:	Ongoing
Project Type:	AOP
DOE Funding FY 2014:	\$1,575,000
DOE Funding FY 2015:	\$1,500,000
DOE Funding FY 2016:	\$1,500,000
DOE Funding FY 2017:	\$1,500,000

refine solutions. By working with experimentalists, we decide on problems that can be solved with simulation that could otherwise not be solved or would take too long with experiment alone to reach BETO's targets. We have produced solutions that have resulted in a 10x increase in muconate yield, an aerobic reactor model that predicts cost changes with size and design, and catalyst enhancements that increase muconate upgrading from 10% to 90% utilization, and we have also designed enzyme mutations for enhanced hydrolysis and metabolic tuning. We find methods to overcome specific barriers

Weighted Project Score: 9.0

Weighting: For ongoing projects, there is equal weighting across all four evaluation criteria: Approach, Relevance, Accomplishments and Progress, and Future Work.

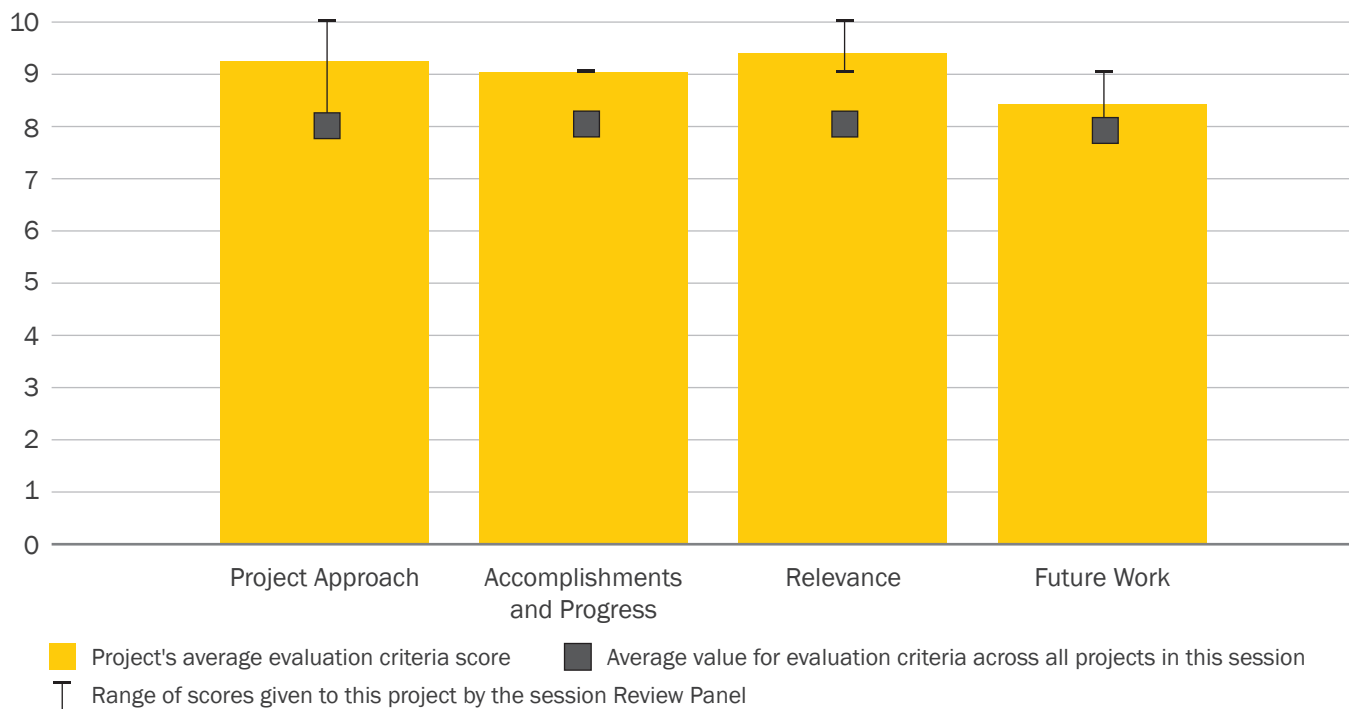

and continue to develop those methods. This project is essential in the process of selecting the final processes for 2022 biofuel production targets.

Overall Impressions

- Overall, the combined efforts in the three task areas look excellent. The goal of using computational modeling to reduce the scope of experimental testing and validation is very valid, and this is certainly an active area in enzyme development, synthetic biology, and process development elsewhere. The NREL team can certainly add to that trend and make significant contributions by putting tools and results into the public domain.

It would be good to see how the metabolic modeling effort will interact with the Agile BioFoundry effort. From the examples shown, it wasn't clear how many suggested mutations were generated for the precise metabolic engineering efforts. It may be useful to consider explicitly the involvement of the metabolic model technology in the "learn part of the design-build-test-learn for the high-throughput strain generation effort in the Agile BioFoundry.

- Computational modeling was brought into the program several years ago as a means to reduce uncertainty in experimental design and to help provide insight regarding reactions and processes. This goal has been nicely met, and the presentation described a number of success stories about the interaction of computation and research. Overall, the potential for modeling work to be applicable to industry is clear. This is an important component of the NREL work and a useful tool for experimentalists. This is a nice program and a nice presentation that provides an overview of an area of huge potential importance for BETO.
- The Biochemical Process Modeling and Simulation program uses theory and simulation to predict performance at ranges of conditions not studied experimentally. The goal is to reduce the experimental

effort by using these results to set tighter boundaries on the range of conditions/strains/pathways tested experimentally. So far, this effort appears to be extremely successful in making advances that contribute to reaching goals of multiple other programs.

- Biochemical Process Modeling and Simulation contributes valuable, actionable insights across bio- and thermo-conversion projects. From micro- to macro-scale, this project provides targets for protein engineering, carbon flux manipulation, and reactor design, to name a few. They work closely with the projects, and predictions are tested empirically to both improve productivity and performance and to advance the model. Numerous successful examples were described. Biochemical Process Modeling and Simulation also contributes to TEAs. Modeling insights can save time, explore larger design space, and suggest novel changes for experimental validation. The organization and collaboration of this team seems exemplary.
- Progress has been made on many aspects of modeling and simulation. The diverse topic landscape and the need to specialize in each discipline to enable expediting the cross talk between modeling and wet laboratories may require more focus in the future. However, so far, this appears to be a working model with a highly accomplished team. This is a very relevant support function and very much in line with enhancing the discovery and decision making for hydrocarbon fuels and chemicals, biologically and chemically. I expect to see more of this computational approach in the future to guide decision making, as knowledge in this field is growing through academia and industry. Great job, and keep the momentum going.

PI Response to Reviewer Comments

- We value the Review Panel's work in evaluating this project and are grateful for the efforts and insights given. We plan to continue to increase our impact

and collaboration in experimental efforts, increase the productive dialogue, and apply our efforts and expertise to the most relevant problems, as determined by TEA analysis of highest-impact topics, applicability of methods, and ability to deliver helpful solutions in a useful timeframe. The connections to TEA are very high on our priority list, and we have made significant progress in developing the collaborative mechanisms and dialogues; there is still a lot of room for progress and improvement. There are two aspects to this collaborative work: information flow in each direction.

Biochemical Process Modeling and Simulation depends heavily on TEA to identify the most important places to work and which projects will have the most impact on achieving the BETO goals. We also aim to improve the precision and, hopefully, accuracy of the TEA, where possible, through more physics-based

models and parameterization. This is a non-trivial undertaking, largely due to differences in scale and computational complexity and simplicity in the two endeavors. However, we plan to continue to make the connections and contributions stronger and more impactful. One specific example of current collaboration with the TEA team is the calculation of maximum theoretical yield in platform microorganisms that are more accurate than what was used by the TEA team in the past. Previously, these theoretical yields came from approximation, extrapolation, or literature searches.

We are already working closely with Agile Bio-Foundry in *P. putida* research and will continue to increase our collaboration as we find applicable. We are aware that the number of projects can exceed our capability, and we will continue to down-select so our impact is the greatest.

ANALYTICAL METHODS DEVELOPMENT AND SUPPORT

(WBS#: 2.5.1.101)

Project Description

The goals of the Analytical Development and Support project are to enable biofuel and bioproducts R&D at NREL by ensuring high-quality analytical data and to advance the tools available to the wider community through method development and globally adopted procedures. Our project is divided into two tasks: one task to improve existing analytical methods and to develop and implement new methods, and one task to maintain existing analytical facilities at NREL and to provide outreach to external stakeholders. We actively cultivate partnerships with industry, academia, and other government laboratories, based largely on our reputation for excellence in analytical chemistry.

The Analytical Development and Support Project is best known for our publicly available LAPs, which provide de-

Recipient:	National Renewable Energy Laboratory
Principal Investigator:	Ed Wolfrum
Project Dates:	10/1/2015-9/30/2018
Project Category:	Ongoing
Project Type:	AOP
DOE Funding FY 2014:	\$0
DOE Funding FY 2015:	\$1,200,000
DOE Funding FY 2016:	\$1,200,000
DOE Funding FY 2017:	\$1,200,000

tailed methods for the summative analysis of biomass materials. Our work is relevant to the overall goals of the program because robust, accurate, precise analytical methods that can be easily and widely implemented help decrease the costs associated with analytical measurements; this is a critical enabling activity both for other NREL researchers and for the larger biofuels research community.

Overall Impressions

- Overall, the project team looks to be doing really well in combining the delivery of quality data to

Weighted Project Score: 9.2

Weighting: For ongoing projects, there is equal weighting across all four evaluation criteria: Approach, Relevance, Accomplishments and Progress, and Future Work.

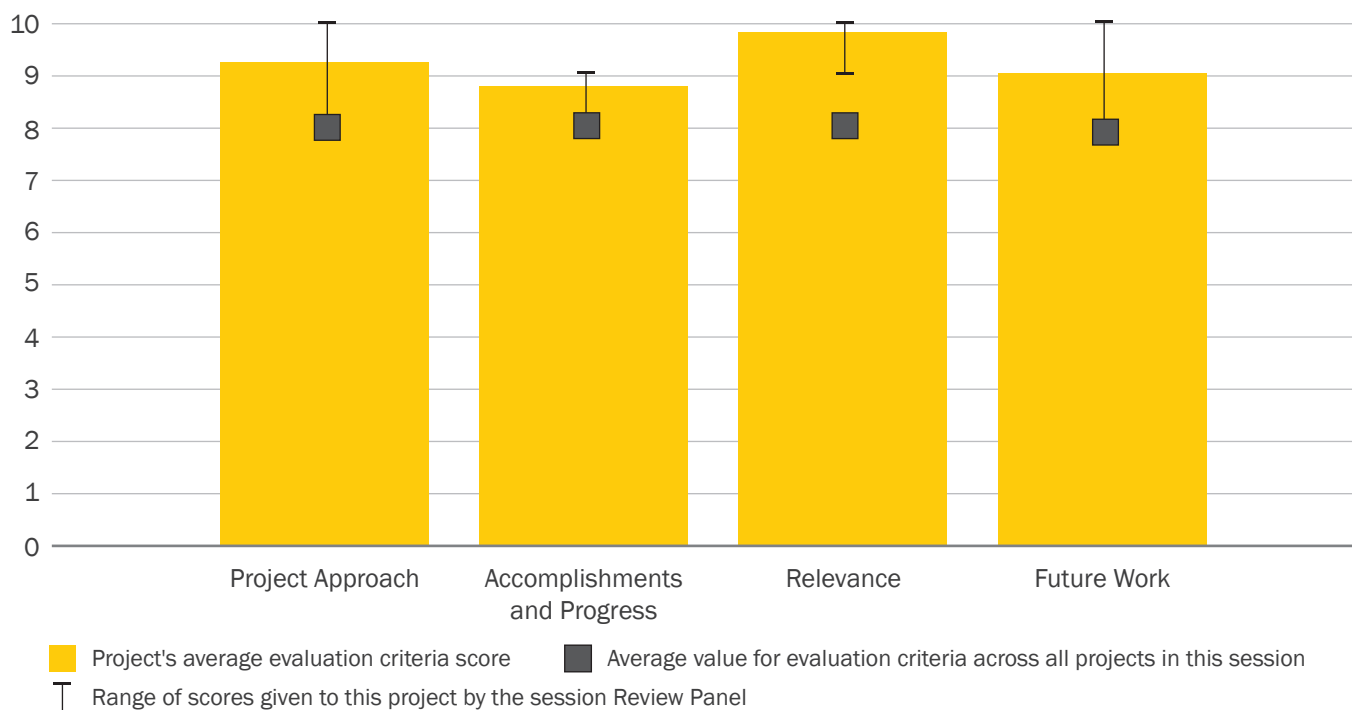

Frequently Asked Questions

- + Where can I find past LAPs?
- + Does NREL offer training?
- + Does NREL perform compositional analysis?
- + I have a limited quantity of sample or a large number of samples for NREL analysis. What are my options?
- + Where can I find a list of compositional analyses on a variety of samples?
- + How can I analyze a feedstock without a coefficient for acid soluble lignin listed in the LAP?
- What vacuum filtration system does NREL use for separating AIR from hydrolyzate?

NREL uses the system pictured here. This consists of a vacuum flask with a rubber crucible holder and a filtration crucible attached to an in-house vacuum line. The vacuum attachment consists of vacuum-appropriate tubing and quick-connect coupling to an in-house vacuum line.



researchers working on internal NREL projects and outside partners with the development of new methods. The project highlights the role that a national laboratory can play in doing work that is central to a range of processes and releasing data into the public domain, thereby saving industry a significant amount of money. The laboratory also appears to perform an important role in standardizing analytical methods across the industry. Although, in the end, industrial projects are deemed successful or not by the economics of production, there are many steps along the way where accurate benchmarking can help them find out if they are on the right path and reduce the risk that their own analytical methods are misleading. The outreach effort performed by the group is phenomenal.

- What's not to like? This is one of the most important parts of the BETO program. Biomass analysis is difficult, fussy, and can give wildly different results if carried out incorrectly, or even if carried out in different laboratories. By supporting an effort to standardize methodology and distribute this methodology to the larger biorefining community, more credible data can be obtained to help direct internal research and TEA, as well as providing information to support industry's investigation of biomass as an

alternative feedstock. Although the team might consider incorporating nuclear magnetic resonance and data mining into their effort, I would echo previous reviews on this superb activity: keep doing what you're doing.

- The purpose of this program is to develop analytical tools (Task 1) and supply high-quality data (Task 2) to the entire Biochemical Conversion Technology Area. It is one of the invisible machines that keeps everything running smoothly. They have done a commendable job running samples in a timely manner for multiple projects and delivering high-quality data (accurate, precise, consistent, and relevant). In addition, the team supports their instruments and those in other laboratories. All of these activities are extremely important to keeping the projects running without delay. The team also supports industry and other national laboratories with standards and methods.
- This project/team is well-known for developing and sharing new analytical methods that enable the industry. Protocols are published and become industry standards, with tens of thousands of page views and thousands of downloads. They continue to identify the most relevant needs. This is exactly the team that should be working with the U.S. Environmental Protection Agency to define the methods for D3 Renewable Identification Number credits.
- The high-quality data is maintained through the good skills and expertise built in the group and good maintenance of the equipment. The challenges of keeping up with moving-target needs from project teams and quickly developing sufficient, robust methods are well-addressed. Having to specialize on many analytical methods for sugars, enzymes fermentations, pretreatment, etc., and maintaining four laboratories with a large number of analytical instruments is well-handled by the project leader. Challenges with pilot-scale analytics are also

well-addressed. I recommended having a better data repository system to enable data sharing, faster analysis, and, later, perhaps data mining and modeling. On a more organizational level, BETO is advised to consider spacing the review cycle of such an important supporting function. This is not a project in my mind, but mandatory to BETO's success competency.

PI Response to Reviewer Comments

- We thank the reviewers for their detailed comments on this project. Our main focus is on analytical data quality, and we believe that our support of four different laboratories and multiple instruments is an extremely valuable (if somewhat “invisible”) contribution to the NREL Biochemical Technology Area as a whole.

We believe our other internal-facing activities to coordinate analytical chemistry and maintain analytical laboratories and analytical instruments ensure consistent and high-quality analytical data in the most cost-effective manner possible. We agree that a more robust Laboratory Information Management System for data tracking and delivery would be helpful. We will examine our current efforts on scientific data management and look for cost-effective ways to improve this. We will also continue our method work to develop robust methods for constituent mass balances for pilot-scale alkaline pretreatment experiments.

We believe that our external-facing activities, principally the maintenance and periodic updating of our website containing LAPs, along with our involvement with ASTM, help to provide a set of common analytical methods with established precision and accuracy. This serves the broader research community and saves many different research groups significant time, effort, and expense

trying to “reinvent the wheel.” We believe our work to develop, maintain and then license near-infrared calibration data sets for rapid biomass compositional analysis is a powerful and cost-effective method to enable the larger biofuel/bioproducts industry by decreasing the cost of primary analytical measurements. Our ongoing work helping to develop robust, standard methods to characterize corn ethanol plant process intermediate streams for proper fuel Renewable Identification Number valuation should help bring clarity to an issue of concern to many stakeholders. In the future, we will continue our external collaborations, including with our external colleagues addressing Gen1.5 ethanol issues.

higher than hydrophobic membranes, or if they are made from much less expensive materials, then hydrophilic membranes may be the most cost-effective option for streams containing more water than organics. Alternatively, if the aqueous stream contains less water than organics, then hydrophilic membranes may be the best option, although this is not the case for most aqueous product streams.

Traditional separation methods for acetic acid from water include energy-intensive distillation processes. Membrane separations have the potential to improve the energy efficiency of the process. In future work, we will conduct more separation tests to provide better data to improve the techno-economic analysis in order to justify membrane performance and economics.

Regarding dewatering, we agree with the reviewer. Too many downstream upgrading and separation steps will negatively impact economics. Sending the concentrated organics to hydrotreating for fuel production does not require additional equipment, but impact on fuel selling price may not be significant. Thus, converting organics to higher-value chemicals is necessary, but additional costs will depend on conversion performance/selectivity, separation technology, and product selling price.

ADVANCED SUPERVISORY CONTROL AND DATA ACQUISITION (SCADA) FOR BIOCHEMICAL PROCESS INTEGRATION (WITH BEND)

(WBS#: 2.5.1.102)

Project Description

Commercial viability of advanced biofuel biorefineries will depend on their ability to process lignocellulosic feedstocks that may vary significantly with seasonal conditions and by regional source. Moreover, BETO has identified that maximizing the incorporation of lignin solids into the final fuel is a critical factor for cutting production costs of advanced hydrocarbon biofuels to \$3/gge. Industry representatives at the 2014 BETO Process Integration and Carbon Efficiency Workshop specifically endorsed attaining complete bioconversion of high-solids feedstocks into value-added fuels or products. As such, we are developing process analytical technologies (PAT) to optimize bioconversion of

Recipient:	Pacific Northwest National Laboratory
Principal Investigator:	Jim Collett
Project Dates:	10/1/2016-9/30/2019
Project Category:	Ongoing
Project Type:	AOP
DOE Funding FY 2014:	\$0
DOE Funding FY 2015:	\$300,000
DOE Funding FY 2016:	\$300,000
DOE Funding FY 2017:	\$300,000

biomass feedstocks with variable compositions and high levels of suspended lignin.

The objectives of this project include the following: (1) to enable real-time tracking of critical process parameters in bioconversions of variable, high-solids feedstocks within bioreactors via the novel application of dielectric spectroscopy and near infrared spectroscopy tools that comply with industrial PAT standards, and (2) to reduce bioconversion scale-up risks by using PAT to optimize bioreactor process control systems in the laboratory under actual industrial conditions and also by

Weighted Project Score: 8.6

Weighting: For ongoing projects, there is equal weighting across all four evaluation criteria: Approach, Relevance, Accomplishments and Progress, and Future Work.

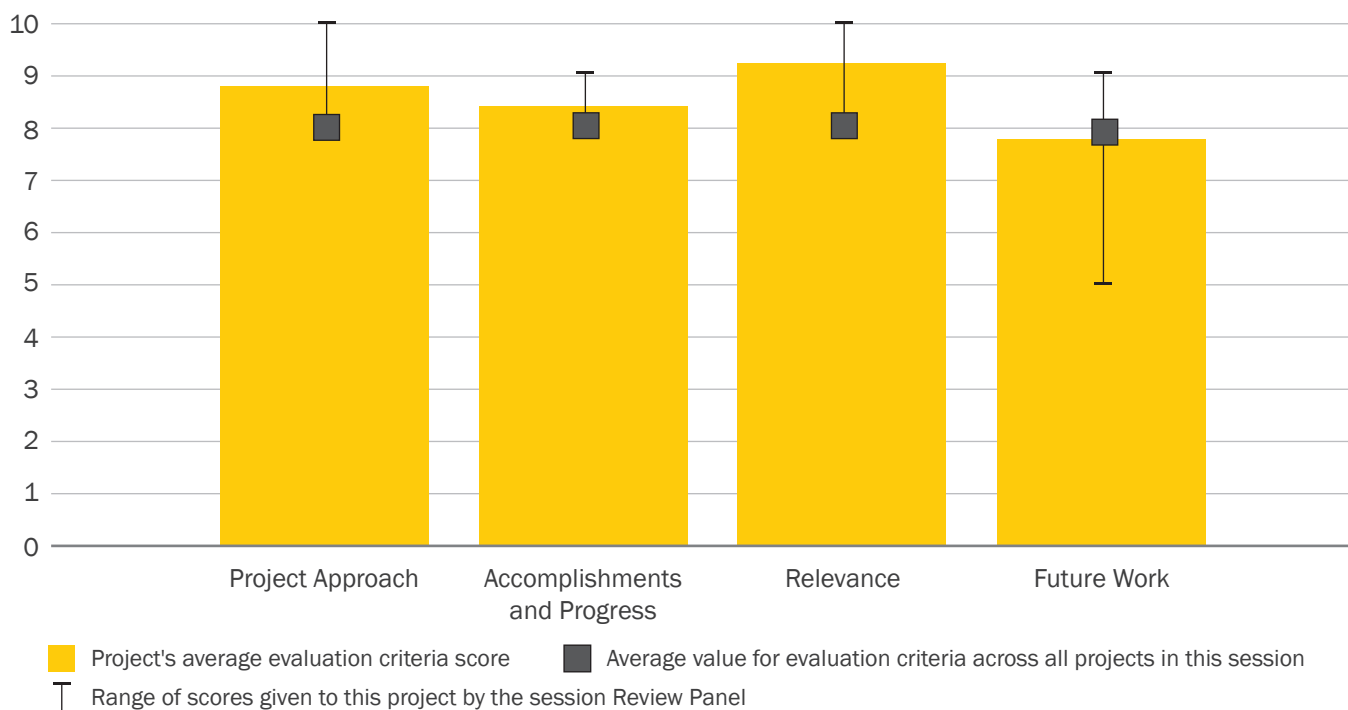



ensuring that these same PAT tools and control systems will scale up and directly integrate into the SCADA networks of commercial biorefineries.

Overall Impressions

- The project has addressed an important area that has attracted some attention in industry but is certainly a growing field and currently under-exploited. The team can provide great value to the biorefinery industry (and also further afield) by testing out the validity of the three technologies under study when applied to the complex mixtures seen in cellulosic bioprocess streams.

A further benefit is the software side of this project, testing out tools that can be integrated to bring together the data from online and offline monitoring, process conditions and set points, and starting material. Demonstrating a system and advising

companies (particularly small companies) on configurations they can build would be a key output of the project.

Looking at the other presentations at the review, there are some obvious collaborations within the national laboratory system that could be beneficial here, particularly with the NREL analytical effort (developing a broader chemometric model for near-infrared spectroscopy on feedstocks for instance), and the computational modeling effort also at NREL.

Overall, this is a really great idea producing very promising results.

- As bioprocesses move from the laboratory to industrial use, successful scale-up is critical. However, understanding and monitoring these larger-scale operations is equally important. This work is developing some nice tools for following processes in real time and providing rapid feedback regarding the operation of a process. The integration of these techniques with laboratory management software and their utility in helping process automation is a real strength. As the project goes forward, better integration with the existing large-scale facilities in the BETO portfolio is recommended.
- The objective of this program is to develop complex control systems for fermentations and other unit operations in bioconversion. This is important for second-generation biofuels in particular because of variability in feedstocks and intermediate streams that affect downstream processes. The team has taken an innovative approach, implementing off-the-shelf instrumentation for a particular program (oleaginous yeast fermentation) with the eventual goal of generalizing to any unit operation. Due to support from instrument vendors, this program was operated with relatively low DOE funding. So, the return on investment for BETO was high. The overall system will likely not be ready to contribute to

2022 goals, but it may be essential for commercial viability of biorefineries. The use of machine learning to incorporate analytical data and metadata is especially promising. Development will take a long time (in particular, collecting enough data to build the model), so now is the right time to start.

- Introducing commercially proven technology to improve monitoring and automated control has significant potential impact on performance and cost. Reducing the need for manual intervention, sampling, and technical expertise may improve efficiency and reproducibility. There are many variables in these bioenergy processes, and reducing a few could have big impact!
- This is a great and much-needed approach. The team has realistic and achievable goals: reducing manual sampling, improving process control, minimizing loss runs, and enhancing operation excellence. This is very much desired and can drive many BETO's sponsored laboratories to accelerate their R&D time and improve de-risking strategies. I would heartily recommend integrating this effort across other pilot facilities and, where possible, small-scale and bench-scale facilities as well.

PI Response to Reviewer Comments

- We thank the reviewers for their constructive feedback and encouragement.

We appreciate the reviewers' multiple recommendations that we share details of our methods for integrating online spectroscopy into our bioreactor operations with the NREL Process Development Unit and the ABPDU, and we hope to assist them in deploying advanced PAT within their pilot-scale operations as well. We have already reached out to these teams and look forward to working with them more closely during the next 3-year cycle of this project.

We will coordinate our further development of chemometric predictive models for biorefinery operations with the NREL Biomass Compositional Unit to take advantage of their well-established LAPs for rapid analysis of biomass feedstocks. Our collaboration could assist future biorefineries with a consistent, plant-wide approach for chemometric analysis and PAT integration. Moreover, we will share with them our progress in deploying the open-source LabKey Laboratory Information Management System database so that they may consider using it for managing their data and analytical workflows as well.

We are also grateful for the verbal recommendation made by one of the reviewers at the Denver meeting that we consider using the OSI PI (process intelligence) system for integrating online spectroscopy data with other sensor, event, and metadata to support chemometric model development. PI is an enterprise-scale database software suite that is already in use at PNNL to support DOE-funded research on electrical-grid SCADA systems. We are now examining how to link the LabKey Laboratory Information Management System with the PI Data Archive for automated integration of offline sample data with online spectroscopy data, other sensor data (such as pH and temperature), and event frames (such as feed pump activation). The integrated time series data may then be matched with process metadata (such as microbial strain information and batch recipe) within the PI Asset Framework to provide more meaningful context to observed process trends. PI analysis tools, such as BatchView and ProcessBook, may then be used for the more rapid assembly of training data sets with a richer collection of class variables, which facilitate identification of latent variables that currently confound robust application of our near-infrared spectroscopy chemometric models across multiple bioreactor runs with varying feedstock lots and operating conditions.

In response to a reviewer's request for further details on how our PAT tools will enable advanced control systems: In a fed-batch operation to produce hydrocarbons from oleaginous yeast, near-infrared spectroscopy appears promising for controlling hydrolysate feeding rates throughout the full course of the process. During logarithmic growth, dielectric spectroscopy may be used for tracking viable cell mass to enable automated shut-off of nitrogen feeding at a targeted cell density to induce the yeast cell lipid synthesis at a point in the batch trajectory that maximizes overall hydrocarbon production. Raman spectroscopy appears promising for tracking the rate of intracellular lipid accumulation, which can enable optimization of hydrolysate and oxygen feeding algorithms that maximize hydrocarbon productivity while potentially minimizing metabolic

overflows into organic acids and other unintended side products. Although the relatively small budget for this project limits the scope of our activities, we see many other immediate opportunities to apply advanced PAT tools throughout the biorefinery; the use of dielectric spectroscopy for real-time tracking of enzymatic hydrolysis has already been demonstrated, and there appear to be many potential uses for the extremely rugged BallProbe (manufactured exclusively by project partner MarqMetrix) for Raman spectroscopy-based process control in upstream and downstream thermochemical operations at high temperatures ($>350^{\circ}\text{C}$), and high pressures ($>6,000$ psi). We look forward to working with our industry partners, our counterparts at the other national laboratories, and BETO to pursue such opportunities as time and budget allow.

AGILE BIOMANUFACTURING FOUNDRY

(WBS#: 2.5.3.104-112)

Project Description

The overall goal of this project is to enable a biorefinery to achieve a positive return on investment through a 50% reduction in the time to scale-up of fuel and chemical production, compared with the current average of ~10 years. This will be accomplished by establishing a distributed Agile Biomanufacturing Foundry (Agile Bio-Foundry), consisting of a consortium of nine national laboratories that will productionize synthetic biology for industrially relevant, optimized chassis organisms. The Agile BioFoundry will constitute a public infrastructure investment that increases U.S. industrial competitiveness and enables new opportunities for private-sector growth and jobs.

Key challenges to be addressed include the efficient catalytic upgrading of sugars/aromatics and gaseous

Recipient:	Lawrence Berkeley National Laboratory, National Renewable Energy Laboratory, Pacific Northwest National Laboratory, Sandia National Laboratories, Los Alamos National Laboratory, Oak Ridge National Laboratory, Argonne National Laboratory, Idaho National Laboratory, Ames Laboratory
Principal Investigator:	Nathan Hillson
Project Dates:	10/1/2015-9/30/2019
Project Category:	New
Project Type:	AOP
DOE Funding FY 2014:	\$0
DOE Funding FY 2015:	\$2,400,000
DOE Funding FY 2016:	\$1,200,000
DOE Funding FY 2017:	\$16,200,000

and bio-oil intermediates to fuels and chemicals; costs of production; and data availability across the supply

Weighted Project Score: 7.9

Weighting: Approach-25%; Relevance-25%; Future Work-50%.

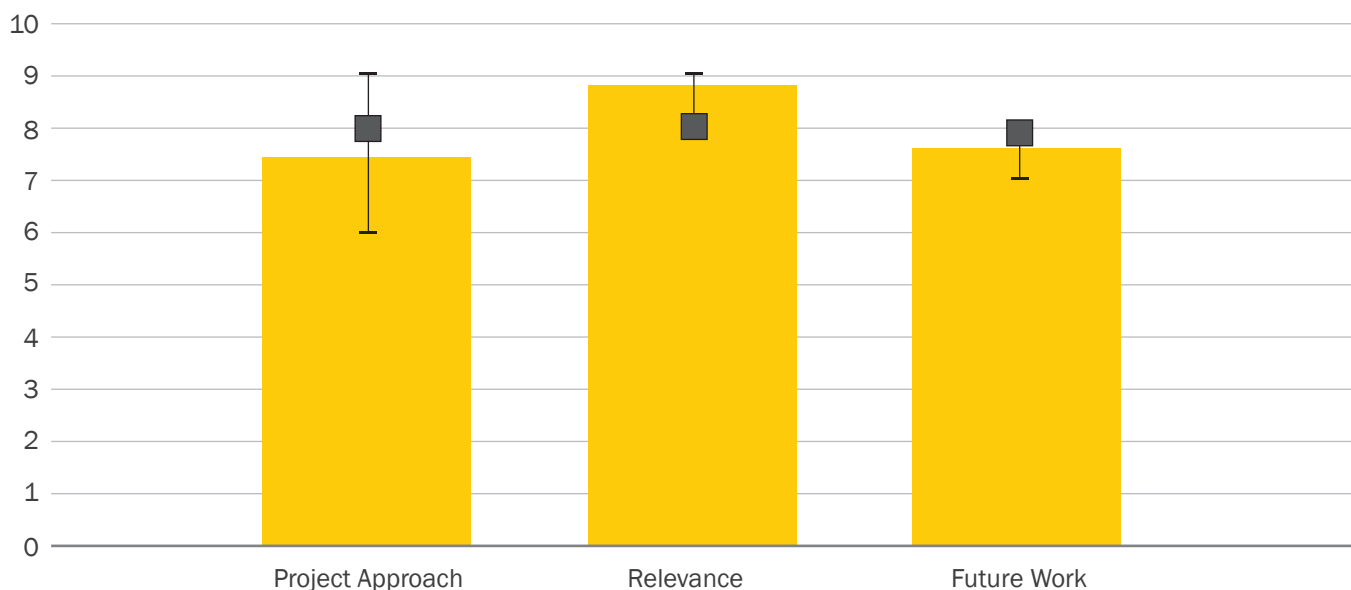

■ Project's average evaluation criteria score
 ■ Average value for evaluation criteria across all projects in this session
 Range of scores given to this project by the session Review Panel

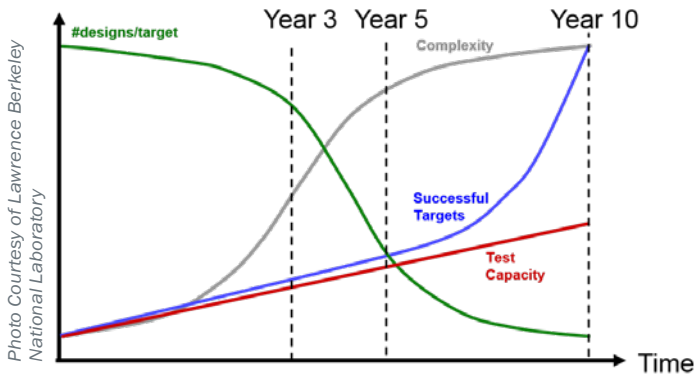

chain. The outcomes of this project will include a 10-fold improvement in design-build-test-learn engineering biology cycle efficiency and new intellectual property and manufacturing technologies effectively translated to U.S. industry, ensuring market transformation. The Agile BioFoundry directly supports BETO's mission and goals and contributes to addressing BETO's Conversion R&D FY 2020 and FY 2021 milestones.

Overall Impressions

- The consortium has a lot going for it. As described in the presentation, there are companies offering synthetic biology platforms to clients, but the technology improvements and learnings will most likely remain closely guarded secrets and be developed separately without cross-interaction. There is a real benefit to having a publicly funded effort developing core tools, engaging with a range of internal and external partners, and being relatively open-source about the tools that are developed. This should provide a system for companies to either use directly as a facility or learn from in developing their own systems. The focus should perhaps be on saving small companies money by not having to all do the same thing in developing tools, providing access to expensive automation equipment and perhaps software tools that would require coding skills that are not present in every company.
- Strengths include the following:
 - The consortium represents a very timely effort that could allow companies to reduce strain development costs, increase speed to market, and de-risk adoption of new technology.
 - It connects people and other resources in the national laboratories to reduce redundancy in technology development and improve cooperation.
 - It offers the opportunity to “push the envelope” and develop platform strains that have been adapted for use in more challenging industrial processes, such as the use of cellulosic sugars.
- Weaknesses include the following:
 - Geographic separation of resources may create problems in communication, sample transfers, and disconnects in technology adaptation (e.g., organism onboarding).
- The team has presented an interesting approach to a key problem in getting products to market. However, they do not yet have a compelling argument as to why and how their approach will be better than other potential approaches to the problem. In addition, the rationale for their choice of product targets needs to be strengthened, as it isn't clear that reducing the cycle time to, say, adipic acid, would be generally applicable to other materials, even those in their current portfolio or specific targets that might be suggested by their industrial advisory board.
- The Agile BioFoundry was created to develop capabilities in synthetic biology that will reduce the commercialization time for a bioprocess. BETO recognizes the need for technology-enabling platforms, and thus, the program specifically addresses one of the missions stated in the MYPP. The program was well-conceived, taking input from the DOE and industry experts, and has a solid management structure and a full-time program manager to ensure accountability. The 3-year targets are very ambi-

tious, but if they are achieved, this would represent a significant advancement. In my opinion, the capabilities, host organisms, and knowledge base that this consortium produces, which can reduce timelines across the industry, is more valuable than hitting milestones on the particular molecules they have chosen.

- In addition to the technical challenges that will arise for each specific product/host combination, there is a logistical challenge with having different tasks spread out among multiple locations. This will have to be managed very closely to ensure there are no unreasonable delays in transferring data, strains, samples, etc. Also, there is no substitute for real-time communication to solve technical problems. In analyzing and interpreting the results of fermentation, for example, it is important to include the fermentation engineer, the scientist who created the strain, and a data scientist all in the conversation. Finally, more emphasis should be placed on the performance gap between small-scale culturing and bench-scale fermentation, which is a well-known problem in the field.
- The presentation was well-organized and delivered. The introduction of new host strains with validated robustness will be welcome and should lead to new bioproducts. The project objective is to level the playing field and enable more participants to introduce new products more quickly, which has high relevance for BETO. The metrics are aggressive (reducing cycle time with new organisms), and the team should be willing to drop combinations that aren't working and have a process for making such decisions. The starting point is known hosts with PIs who have experience with those hosts, which de-risks getting some early successes. Managing the activities of a nine-laboratory consortium will be a challenge, and the organization has thus been carefully considered.
- This is a good initiative and very much needed across the national laboratories and industry. It will be useful for companies to tap into this knowledge in the future and use the infrastructure instead of forming their own. The PI is encouraged to look deeply into high-throughput fermentation techniques mastered by enzymes and biobased chemicals and fuels companies (e.g., Codexis, Verenum, Genomatica, and Amyris). This will foster the team's ability to better conduct the "predictive high-throughput fermentation" concept using a reliable, robust, consistent, and reproducible scale-down model. I will also encourage the PI to form a strong liaison between fermentation and the high-throughput team, as this will likely become a bottleneck to the candidates' nomination for testing process.

PI Response to Reviewer Comments

- We appreciate the detailed input from our Review Panel and will seek to incorporate the feedback as our consortium moves forward. As a distributed effort, we clearly may face some operational challenges, although these are offset by the Agile BioFoundry's ability to leverage physical and human resources across distributed national laboratories. The Agile BioFoundry's full-time program manager, together with regular communications across the consortium (via teleconferences, webinars, informatics servers, SharePoint, annual in-person meetings), will help mitigate the communications risks. Sample transfer risks (i.e., sample stability, sample loss) will be assessed through local/proximal compared with remote sample analysis, and the incidence of lost samples will need to be assessed on an ongoing basis. Disconnects in technology adoption, unfortunately, can be a very significant challenge even within a single location/institution, although it may be further exasperated across geographic locations (especially if there are overlapping methods/infrastructure alternatives). It will be an operational

imperative to standardize workflows and data-exchange formats wherever possible.

What sets the Agile BioFoundry apart from other foundries is that we seek to develop and distribute publicly available tools, methods, and strains aimed at broadly benefiting the biofuels and bioproducts industry. Whereas private foundries are incentivized to develop proprietary tools and organisms, the Agile BioFoundry is a publicly funded effort aimed at delivering technology that will enable industry to either leverage our resources through partnership or adopt our methodologies for developing bioproducts. In comparison to the publicly funded Defense Advanced Research Projects Agency Living Foundries program, there are distinct programmatic and technical differences between the aims of the two efforts. Where the Living Foundries program is primarily focused on developing biological pathways to materials that cannot be achieved through transformations of petroleum feedstocks, the Agile BioFoundry is focused developing biological pathways for producing advanced biofuels and renewable, high-volume chemicals.

The Agile BioFoundry is pursuing multiple target/hosts to demonstrate that the methods, software, and technologies can be productively applied across product classes. The process and rationale for selecting the three target/hosts pairs for FY 2017 (and the 15 pairs for FY 2017–FY 2019) was described during the review, and the details have been provided to BETO. In addition, we will consult the Agile BioFoundry Industry Advisory Board during future evaluation and selection phases to ensure that our

prioritized targets and hosts remain aligned with industry's needs.

Regarding scaling processes from high-throughput, small-scale experiments to pilot-scale process demonstration at NREL and the ABPDU, we recognize there are new challenges associated with each increase. The Agile BioFoundry workflows will leverage design of experiments and small-scale culture to select strains to grow in bench-scale bioreactors. Bench-scale fermentation provides critical data for the “learn” component of design-build-test-learn, both to inform future designs and to develop predictive models that may be applied to small-scale experiments. Transfer from bench-scale bioreactors to pilot-scale fermentation will be reserved for mature strains and processes when there is need and value.

As we progress, the Agile BioFoundry's milestones are written to explicitly drop underperforming target/host pairs. This requires operational discipline, which will be enforced not only by Agile BioFoundry leadership, but also by BETO. The process is largely guided by TRY metrics and go/no-go decision points, although other metrics (e.g., diminishing learn/strategic value) will also play a role in certain circumstances. We note the Review Panel's comments related to developing broader, operational milestones aimed at demonstrating a successful platform, as opposed to those that emphasize TRY. We thank the reviewers for their valuable input, which will be considered in guiding the direction of this program.

MAXIMIZING MULTI-ENZYME SYNERGY IN BIOMASS DEGRADATION IN YEAST

(WBS#: 2.5.3.200)

Project Description

Carbohydrate-active enzymes from various organisms are known to act synergistically in biomass degradation in nature. We aimed to develop synthetic biology technologies to facilitate incorporating some of this synergy into the saccharification process to make the process efficient and cost-effective. Our approach builds on pioneering work by others.

Using a pipeline for gene synthesis, strain construction, and strain testing, we achieved functional expression of 45 enzymes in *Saccharomyces cerevisiae*, representing 11 glycoside hydrolase families. We generated a scaffold with nine sites for enzyme loading. Using CRIS-PR-mediated engineering, we generated 10 strains, each containing nine enzyme constructs across the genome.

Recipient:	J. Craig Venter Institute
Principal Investigator:	Yo Suzuki
Project Dates:	3/15/2013–10/31/2016
Project Category:	Sun-setting
Project Type:	FY 2012–Synthetic Biology: DE-FOA-0000719
Total DOE Funding:	\$1,266,224

Our project's unique goals were shuffling of enzyme constructs and identification of optimal enzyme combinations. We mated the multi-enzyme strains and examined the haploid progeny from one pair extensively.

Using a growth-based assay with pretreated corn stover, we screened 626 progeny and selected three strains to be used for validation. We showed that 20%–30% more ethanol is produced with these strains in a selected condition over the baseline, with a comparable strain not making any cellulase. Our synthetic biology approach can be expanded to additional enzymes and feedstocks. The identified enzymes can be prepared as recombinant proteins and tested for suitability for inclusion in the next generation of enzyme cocktails.

Weighted Project Score: 5.4

Weighting: Approach–25%; Relevance–25%; Future Work–50%.

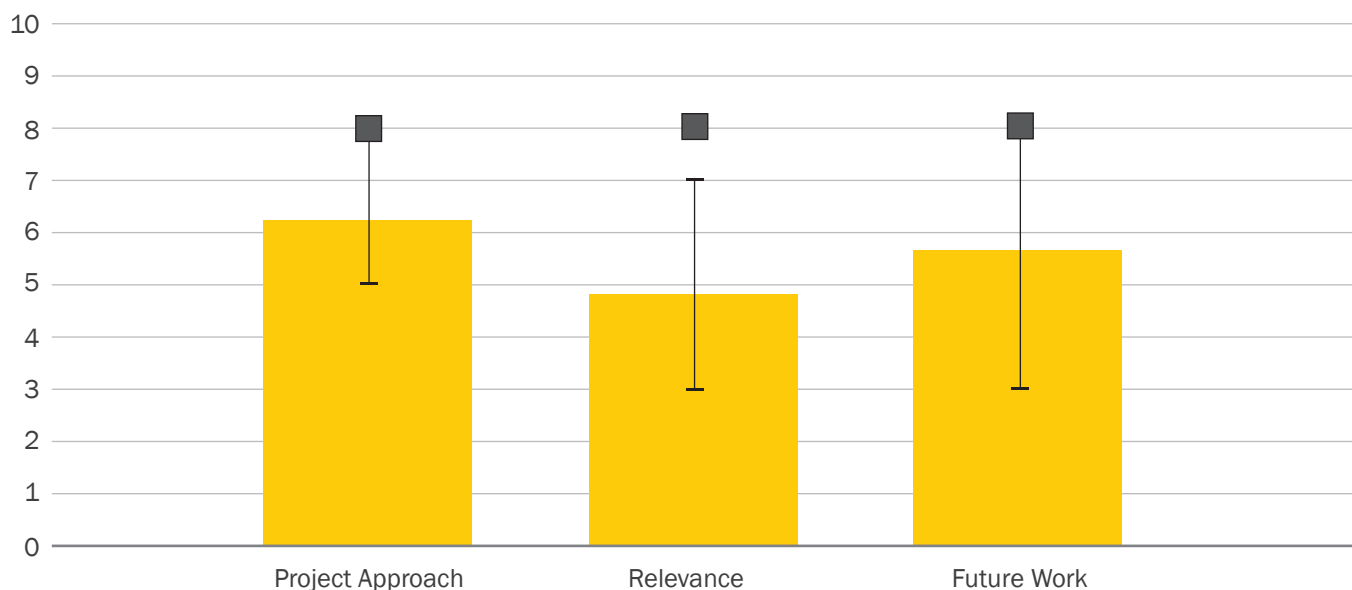

■ Project's average evaluation criteria score
 ■ Average value for evaluation criteria across all projects in this session
 Range of scores given to this project by the session Review Panel

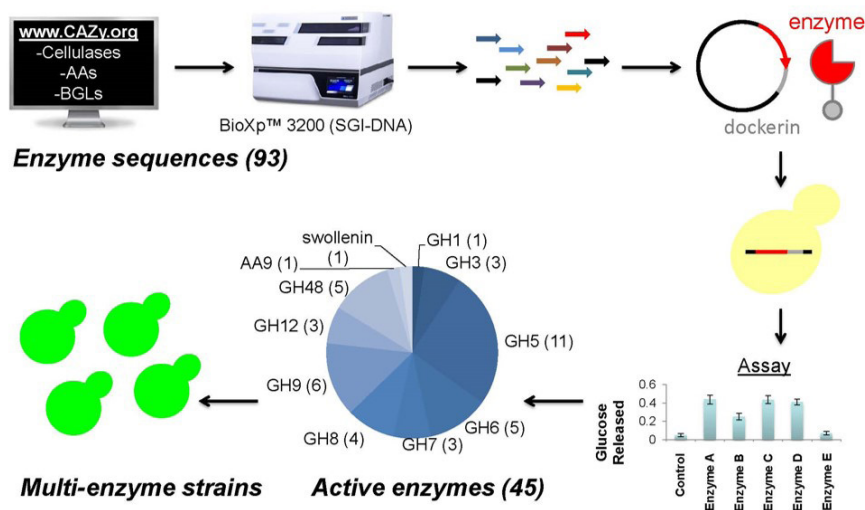

Overall Impressions

- The project contained an interesting idea: introducing expression cassettes for heterologous enzymes into separate locations in the yeast genome to allow shuffling of combinations. The main benefit of using yeast, therefore, was in generating large numbers of combinations of enzymes. It was very unclear from the presentation how many combinations of the enzymes were generated and screened. The testing phase for the final strains appeared to be rather cursory. If there were benefits of expression of cellulases in the yeast strain in reducing exogenous enzyme dosing, this would have been good to examine better using dosing studies. No mention was made of novel synergies detected in the system.
- Overall, what we heard was a story describing a lot of things that didn't work and a lot of problems. They had some successes, and the general concept was interesting, but the approach simply didn't pan out.
- The team developed an efficient workflow for screening multiple cellulases in combination, using automated gene synthesis. The concept of leveraging possible synergy is a good one, though there were no proposed mechanisms of how synergistic interactions would occur. Once the platform was developed, the amount of actual screening performed

was small. Given the high-throughput workflow and the resources available at J. Craig Venter Institute, which is likely why this project was selected for award, I would have expected that a larger number of genes and combinations would have been screened.

- Considering the stated advantages of an existing infrastructure for rapid synthetic biology pipeline, new state-of-the-art facilities, the first BioXP machine, Novozymes as a partner, and generally being at the forefront of synthetic biology, this project was poorly executed. The change from the CBP approach after the 2015 Peer Review seems to have thrown them off of their game.
- Overall, this was a novel way capitalizing on J. Craig Venter Institute's synthetic biology strength. The project didn't deliver the expected outcome and not unexpectedly. Many groups, with and without acceleration through synthetic biology tools, failed in this route, and not unexpectedly, this one did too.

PI Response to Reviewer Comments

- We thank the reviewers for the positive comments, the constructive criticisms, and the good understanding of our project. We realize that our presentation did not emphasize where we started for producing the results we presented. This may have resulted

in some of the negative comments. When we started, synthetic biology studies usually involved model cellulose substrates. We believe that we developed technologies to help link synthetic biology with real biomass substrates. This is an important step forward. At least two technologies we developed are already used at NREL to accelerate BETO-funded projects. We agree with reviewers on the importance of tasks they mentioned, but some of the tasks are apparent only now because advances were made in our research. We would like to think of them as valuable ideas for our future studies.

Regarding the lack of clarity mentioned by the first reviewer on how many enzyme combinations were screened, we estimate to have screened 70% of 512 combinations of enzymes from a cross of two multi-enzyme strains. Mechanistic studies of synergy were out of scope for the project, but we are excited to conduct these studies.

Regarding comments by the second reviewer, we agree that we have had successes and disagree that the approach did not pan out. We can agree that the project has not yet produced exciting results, but the contribution we made in the field is impressive, as mentioned above in our first paragraph. We expanded on almost every aspect of previous synthetic biology work and incorporated a real feedstock. A decision was made not to pursue CBP and to focus on developing a discovery tool for enzyme synergy after the 2015 Project Peer Review meeting, so the goal set at the beginning of the project for CBP applications was not met. A story of a lot of things that did not work is expected for a pioneering (low-

TRL) work, which our project was supposed to be based on the FOA.

Regarding related comments by the third reviewer, we disagree with the poor execution, because low-TRL projects are expected to have a lot of uncertainties. We conducted productive research by dynamically applying our excellent skills to solving problems.

Regarding the comments by the fourth reviewer, we agree that the scale of screening was small. We wished to screen more, but much of the time had to be devoted to developing technologies that formed the basis of screening. However, we can continue screening, and we are writing a paper to disseminate our technologies for others to use.

Regarding the comments by the fifth reviewer on CBP, the reviewer knows this, but we would like the public to also know that the focus of our project shifted after the 2015 Project Peer Review meeting, as described above in our third paragraph. We had successes with the revised goals. The decision not to pursue building CBP organisms based on yeast within the timeframe of our project was excellent, but advances in synthetic biology in yeast are rapid and are making the boundaries between yeast and other organisms blurry. Rewriting the complete genome will soon be possible in yeast. It will then be feasible to incorporate desirable characters from various organisms into yeast.

We would like to benefit from excellent advice from the reviewers and develop future projects around their ideas. Thank you for the opportunity.

SYNTEC—SYNTHETIC BIOLOGY FOR TAILORED ENZYME COCKTAILS

(WBS#: 2.5.3.201)

Project Description

Using a novel enzyme screening method inspired by synthetic biology, Novozymes developed new technology that allows for more rapid tailoring of enzyme cocktails. The methodology can be applied to specific feedstocks and/or coupled to address a specific hydrolytic conversion process context. Using combinatorial high-throughput screening of libraries of enzyme domains, we can quickly assess which combination of catalytic modules delivers the best performance for a specific condition. To demonstrate the effectiveness of the screening process, we measured performance of the output catalytic cocktail compared to CTec3/HTec3 (Cellic CTec3 is a commercial cellulase and hemicellulase complex from Novozymes, and Cellic HTec3 is a commercial enzyme for hemicellulose hydrolysis from

Recipient:	Novozymes Inc.
Principal Investigator:	Sarah Teter
Project Dates:	7/1/2013–12/31/2015
Project Category:	Sun-setting
Project Type:	FY 2012—Synthetic Biology: DE-FOA-0000719
Total DOE Funding:	\$2,500,000
DOE Funding FY 2015:	\$0
DOE Funding FY 2016:	\$500,000
DOE Funding FY 2017:	\$500,000

Novozymes). The test substrate was ammonia fiber expansion pretreated corn stover. CTec3/HTec3 was assayed at the optimal pH and temperature and in the absence of any pH adjustment. The new enzyme cocktail discovered under SynTec was assayed in the absence of pH adjustment and at the optimal temperature. Conversion is delivered by SynTec enzyme at a significant dose reduction relative to CTec3/HTec3 at the controlled pH optimum, and without titrant required to maintain pH, which delivers additional cost savings relative to the current state-of-the-art process. Using a techno-eco-

Weighted Project Score: 8.6

Weighting: Approach—25%; Relevance—25%; Future Work—50%.

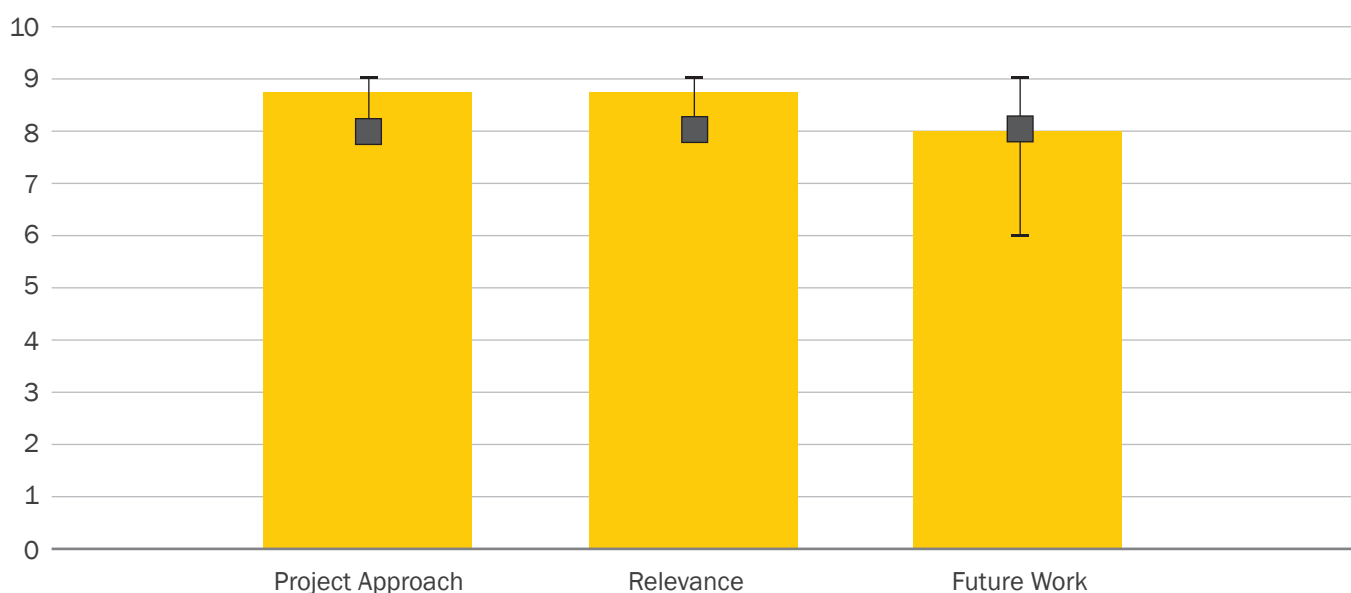

■ Project's average evaluation criteria score
 ■ Average value for evaluation criteria across all projects in this session
 Range of scores given to this project by the session Review Panel

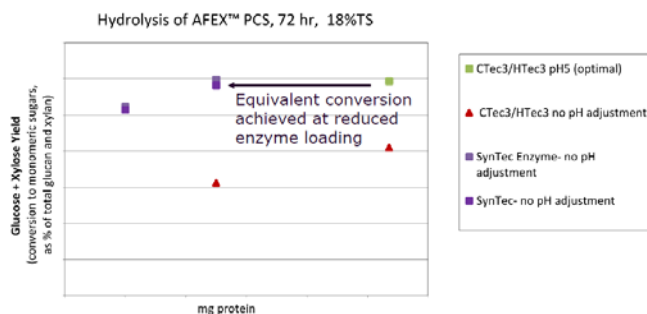

nomic model developed by MBI, this improved enzyme cocktail led to reduced biomass sugar production costs that were 1.4x lower than for the base case (CTec3 used under its optimal conditions).

Overall Impressions

- The project investigated an interesting hypothesis and developed some useful tools for further work in the area. Their most interesting discovery was that supporting multiple enzymes on a scaffold is no more effective than using a cocktail of individual enzymes. Can this result be used to streamline future formulations of cellulase systems?
- In this project, Novozymes developed a rapid cellulase screening protocol leveraging protein scaffolds to incorporate the potential benefit of enzyme co-localization and synergy. Although the targets were not quite met, impressive improvement was achieved. Once the platform was established, this occurred very quickly, demonstrating good potential for future application. I have no doubt that significant progress can be made if this work were to be continued. The project also contributed to general knowledge base on cellulases. No co-localization benefit was found. Some new synergy was elucidated, but nothing remarkable.
- A clever combinatorial high-throughput screening methodology was developed and demonstrated to identify a significantly improved enzyme compo-

sition. The methodology can be used to identify tailored enzyme combinations for different substrates, operating conditions, etc. A composition of 11 enzymes added to CTec3 seems like a complex undertaking for commercialization. It could be a starting point for simplification and removal of minor contributing components. Modifying the composition to eliminate the need for pH control is useful and cost saving. Translation of results to a relevant filamentous fungal host could verify the usefulness of the tool in accelerating commercial development.

- The project goals and technical challenges are well-aligned with BETO's mission to reduce enzyme hydrolysis costs and were largely achieved by a novel screening method to expedite the search through natural diversity and mutagenesis of combinatorial libraries of enzymes, debottlenecking the major challenges—enzyme purification and quantifications. This is very nice development and will allow Novozymes to offer a better package with a lower enzyme load and a broader pH operation spectrum. Kudos for that.

PI Response to Reviewer Comments

- Regarding the potential for engineering a production strain for enzymes discovered in this project, we agree that simplification of the cocktail might be attractive. Generally, we embark on production of “tailored” cocktails by generating a production strain as needed when we have a specific customer in mind. Thus far, we have delivered commercial cocktails for five customers who are operating commercial-scale biorefining facilities. Tailoring a commercial product for ammonia fiber expansion pretreated corn stover (or similar), and absence of pH control, would be warranted if there were a specific customer intending to utilize this type of process at commercial scale.

DESIGN AND OPTIMIZATION OF BIOCHEMICAL / BIOFUEL PRODUCTION WITH BIOSENSOR-GUIDED SYNTHETIC EVOLUTION

(WBS#: 2.5.3.203)

Project Description

Using novel strategies derived from synthetic biology, this research effort supported Lygos' development of a biocatalyst for conversion of sugar feedstocks into fine and commodity chemicals. Specifically, Lygos targeted compounds that are currently derived from petroleum using inefficient, ecologically hazardous chemical processes. To date, market expansion for select compounds has also been inhibited by high production costs and low process yields. Lygos developed high-yielding microbial catalysts that will be cost-advantaged relative to existing chemical routes. The goal of this project was to develop rapid, inexpensive methods to generate biocatalysts that

Recipient:	Lygos Inc.
Principal Investigator:	Eric Steen
Project Dates:	3/1/2013–10/31/2016
Project Category:	Sun-setting
Project Type:	FY 2012–Synthetic Biology: DE-FOA-0000719
Total DOE Funding:	\$1,783,072

employ non-food biomass feedstocks to make the valuable chemicals and decrease our reliance on petroleum.

In this project, Lygos scientists and engineers built and employed a process for engineering biocatalysts, encompassing software design tools, physical DNA editing tools, high-throughput screening strategies using biosensor-guided evolution, and a software management system for statistical analysis. While the approach was deployed for production of a single, specialty biochemical, malonic acid, it could be broadly applicable to other products and biocatalyst engineering efforts. Finally, our strain engineering efforts were validated in a fermentation process to 50 liters, using cellulosic sugar.

Weighted Project Score: 8.3

Weighting: Approach–25%; Relevance–25%; Future Work–50%.

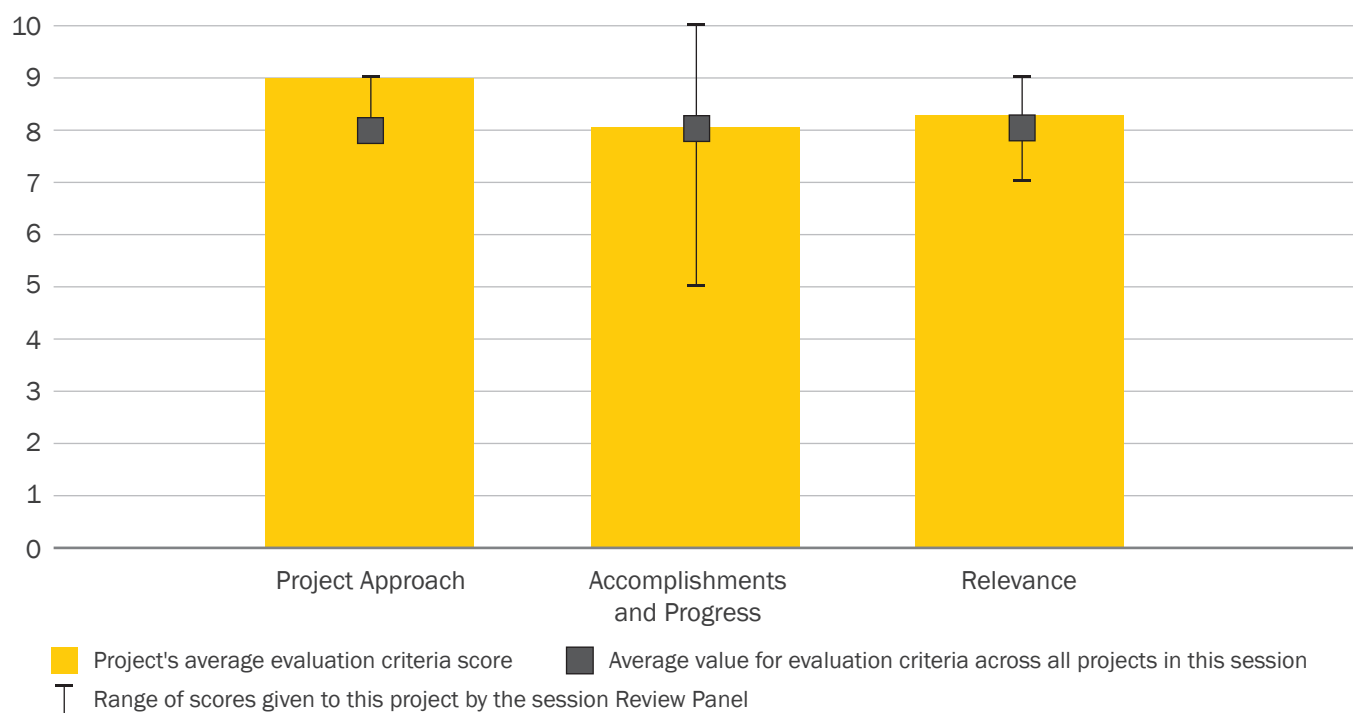

Overall Impressions

- The presentation gave a strong impression of a well-run project that has achieved its goals. The slides showed a clear logical progression and comprehensive approach, with good use of project management methodologies. Overall, the project shows development of a solid, functional, iterative strain construction and metabolic engineering platform that could be applied to a range of target products.

The first target chosen is a relevant commercial chemical, and the metabolic pathway suggests a benefit in incorporating CO₂ into the product to raise the yield on sugar above 1. This individual presentation does not disclose TRY for malonic acid achieved so far, but the selection of target and approach to strain and process development look sound.

The project is a great demonstration of how public funding can allow private companies to take a risk and develop technology that has the potential to generate much larger economic benefits down the road, and should provide a great return on investment.

- Lygos carried out a well-organized program in genetic engineering that displayed a nice combination of computational work with organism development. The transition to malonic acid production added utility to the process by providing access to a known chemical product. However, the costs are currently quite high, and the plan to target boutique users is not sustainable in the long run.
- High-throughput methods for optimizing biocatalyst performance are needed to speed up the pace of all metabolic engineering projects, which would benefit BETO and the entire industrial biotechnology industry. One of the goals of this program was to develop a biosensor, but unfortunately this was not sufficient for a reliable, high-throughput screen. Hopefully more work will be done on this since tying a bio-

sensor to growth could enable very high-throughput selection with application to many projects. The particular choice of malonic acid as the target is questionable. Their preliminary TEA determined a potential production cost, but neither the current price nor the market need were discussed.

- This is a good demonstration of implementation to practice using a novel strain and design-build-test-learn model to allow faster development of a biobased chemical—which, eventually, if it is economically viable, will allow a more sustainable production of this and other molecules down the road. Now that Lygos has a working workflow and developed the skills and expertise to accelerate strain and process development timelines, it will evidently become a faster process for them for any new molecule. Great work and good luck on partnering with industry on scaling this up.

PI Response to Reviewer Comments

- Lygos greatly appreciates the DOE support and reviewers' positive feedback on our successfully organized and executed project, including a combination of computational software tools, genetic engineering tools, and high-throughput biosensor screening with a focus on producing bio-malonic™ acid. This support and project was critical for Lygos in developing our malonic acid technology.

Lygos is pleased that, overall, the reviewers' comments recognize the value of our approach in building a platform for rapid engineering of microbes and the specific success the project achieved in demonstrating commercial readiness for our flagship product, bio-malonic™ acid. Now that the platform for engineering is in place, continued improvement of the bio-malonic acid process and future target products are expected to advance even more efficiently.

We appreciate the reviewers' feedback that high-throughput methods are required for optimizing biocatalyst performance and advancing the field,

which was one of the goals of developing a biosensor. We indeed developed a reliable, high-throughput screen using the biosensor, where we attained a high correlation of the biosensor to high-performance liquid chromatograph readings of bio-malonic acid concentration (R² 0.9). We believe this strategy could be broadly impactful to the industry. The screen we developed enabled Lygos to conduct numerous design, build, test, and learn cycles and identify genetic modifications that improved process performance, attaining more than 2,100 strains built and screened per scientist. In the future, Lygos may implement the biosensor screen on a robotics screening platform to further decrease labor requirements and improve screening capacity beyond 2,100 strains per scientist.

We appreciate the reviewers' support for Lygos' product selection of malonic acid. As one described, "The project team seem to have clearly thought about the choice of target molecule (A top 30 molecule from the DOE analysis,³² the size of the market, sequestration of carbon, and reduction in production of a toxic byproduct by displacement of the petrochemical process."

In more detail and as described in the project, bio-malonic acid is an ideal target for bio-production and was identified previously by DOE as one of the top 30 molecules that could be produced from lignocellulosic sugars. First, it represents a common node of metabolism from which numerous other biological products are derived. Second, it is a toxic, expensive, cyanide-derived product today, and production is restricted to China. Third, because of Lygos' bio-malonic acid pathway's high theoretical yield, it can be produced at lower cost and enable major market expansion. Specific market and pricing discussions are confidential and were beyond the scope of the public forum. However, Lygos' proprietary technology to produce bio-malonic acid promises to enable better quality and expanded supply compared to the current cyanide-based product. We plan to compete on all of these elements as we continue to commercialize bio-malonic acid.

We look forward to continuing to advance and commercialize bio-malonic acid.

³² T. Werpy and G. Petersen, eds., *Top Value Added Chemicals from Biomass: Volume I—Results of Screening for Potential Candidates from Sugars and Synthesis Gas* (Golden, CO: National Renewable Energy Laboratory, August 2004), <https://www.nrel.gov/docs/fy04osti/35523.pdf>.

SYNTHETIC MICROORGANISMS TO ENABLE LIGNIN-TO-FUEL CONVERSION

(WBS#: 2.5.3.205)

Project Description

The proposed research aims to address one of the most challenging issues in lignocellulosic biorefinery: utilizing lignin for fungible products. The research integrates synthetic biology design of microorganisms, fractionation of lignin, and fermentation optimization.

The lignin-to-lipid platform will achieve more complete usage of carbon in biomass, increase the net energy gain and carbon balance, enhance the economics and self-sufficiency of biorefineries, and alleviate the shortage of lipid for biodiesel production.

Recipient:	Texas AgriLife Research
Principal Investigator:	Joshua Yuan
Project Dates:	7/1/2013–6/30/2016
Project Category:	Sun-setting
Project Type:	FY 2012–Synthetic Biology: DE-FOA-0000719
Total DOE Funding:	\$2,399,977

The research will address three major technical barriers: lignin depolymerization, carbon flux to higher lipid yield, and optimized fermentation for scaling up.

We have achieved most of the major technical milestones. First and foremost, we have achieved 11 g/L of lipid titer for biorefinery waste conversion. Second, we have achieved over 120 colony-forming units/milliliter laccase production and 13.6 g/L protein secretion from *Rhodococcus opacus*.

Weighted Project Score: 8.1

Weighting: Approach–25%; Relevance–25%; Future Work–50%.

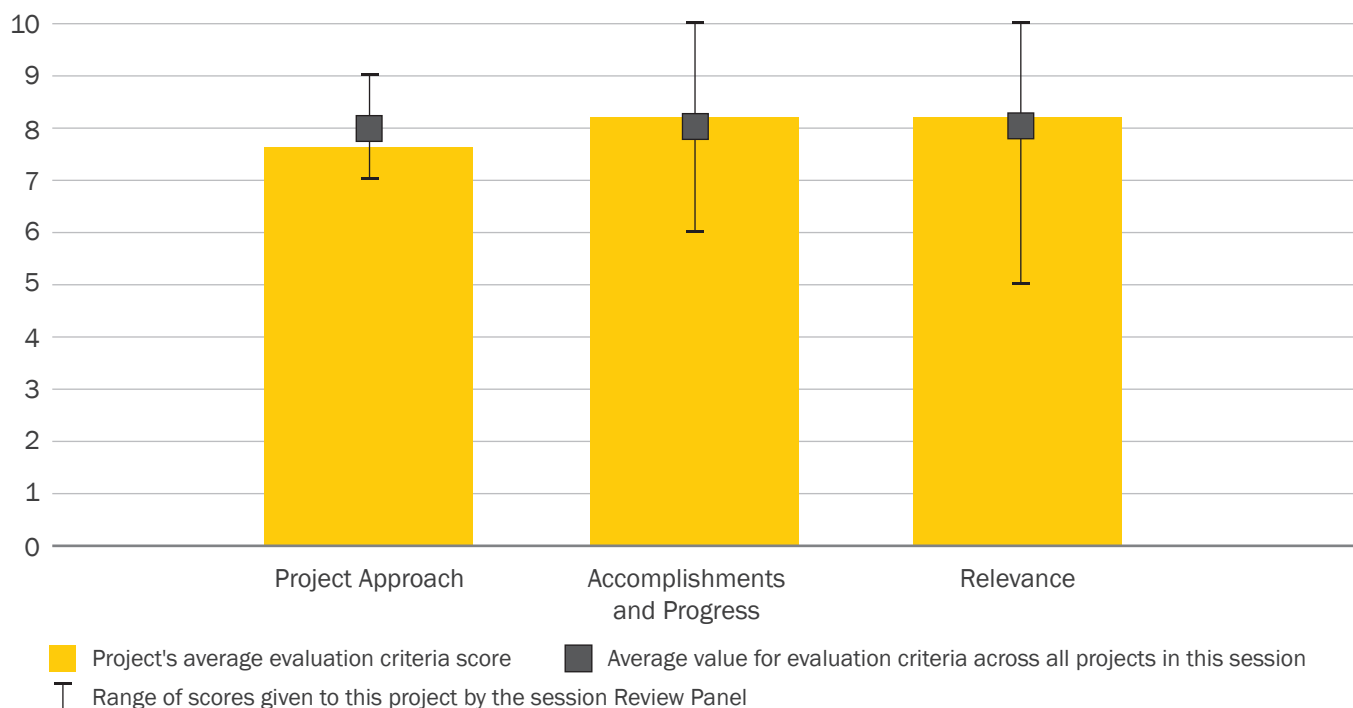

Overall Impressions

- The project has some elements that look promising: laccase production in a Gram-positive bacterium at 13 g/L and lipid production from lignin material. However, the presentation of the data and progress towards goals was fragmented and difficult to follow. It was challenging to see from the presentation exactly where the project currently is in relation to an economically viable process. Obviously, there are almost 4 years of experimentation underlying the presentation, but it really would have benefited from more selective choice of data and clearer explanations, particularly on the metabolic engineering for lipid production and the different forms of lignin streams being used.
- The PI has developed an interesting process for converting lignin into higher-value lipids. The increase in value will be smaller with biodiesel as the product, but converting the lignin to a more tractable fuel is a useful contribution to the larger BETO program.
- This project has developed a single organism for enzymatic lignin fractionation and subsequent conversion of monomers to lipids. Both laccase expression and lipid content of this strain are quite impressive. The team should evaluate whether there is any advantage in using two separate strains for laccase expression and monomer conversion. The project is on track to hit the milestones, though this is a challenging effort and still a long way from commercialization. There is potential to consolidate this work with other lignin valorization projects within BETO.
- This project is moving into the final stage, a scale-up to 2 liters with concomitant TEA. Nice progress was made in laccase secretion for depolymerization and metabolic engineering to increase lignin-to-lipid production by *Rhodococcus*. I'm surprised that *Rhodococcus* can apparently secrete laccase for

depolymerization and still maintain TRY for lipid production. Many papers, and two patent applications, were written related to this process, and it has apparently been licensed.

- This is a good and energetic team. They are doing a lot of good work in the right direction in close alignment with industrial partners (Archer Daniels Midland and ICM Inc.), which will likely, if technical and economic viability can be realized, end up in a commercialization track. The PI is advised to have a routine benchmarking against critical TEA analysis as a way to articulate progress toward economic goals. Great job!

PI Response to Reviewer Comments

- We appreciate the reviewers recognizing the progresses and impact as impressive.

First, regarding to the choice of data and clarity of presentation, we apologize that we had to summarize the data from more than 10 publications, the efforts of utilizing different substrates, and the research ranging from microbial engineering to process optimization, all within 15 minutes. The project itself has evolved during the past 4 years. At the time of initial selection, there was very little research on lignin bioconversion in the field. The project, thus, was focusing on synthetic biology engineering of microorganisms to convert lignin. During the past 4 years, the project evolved to focus on bioconversion of various biorefinery streams, where the substrates, scope, and technologies all expanded significantly. The substrate itself expanded from kraft lignin to several biorefinery waste streams from acid and ammonia fiber expansion pretreatments, and produced by ADM, Michigan Biotechnology Institute, and ICM, Inc. The initial focus of metabolic engineering was also expanded to integrate fractionation technology development and fermentation optimization with strain engineering to improve bioconversion. The evolving proj-

ect scope, the multiple publications generated, the multi-scale deliverables, and the overall complexity of the project might have contributed to some confusion of the presentation.

Second, the reviewer has raised a very good question regarding the balance of laccase secretion and lipid production. When the enzyme is produced at very high titer (e.g., >5 g/L), the lipid production can be significantly compromised. In order to mitigate the challenge, we developed two alternative strategies for bioconversion: (1) consolidated lignin processing and (2) fractionation (enzymatic or chemical) followed by fermentation. We can use the *R. opacus* strain to produce laccase enzyme and subsequently use the enzyme to fractionate lignin for fermentation, or we can use consolidated processing, where the same *R. opacus* strain produces enzyme and lipid. We have developed a series of strains producing laccase at different levels for different applications.

Third, regarding the benchmarking against critical TEA, we agreed with the reviewer. The project has an initial TEA, and we have evaluated how technical progresses contributed to economic feasibility. More comprehensive analysis is being carried out using the ASPEN model, with lipid production platform bolt on at a cellulosic ethanol plant.

Fourth, regarding the consolidation of this work with other lignin valorization work, we have already discussed synergy and collaboration with the relevant PIs. Importantly, based on our discussion and project review, the efforts among different waste utilization projects are very complementary to one another, and there is no significant redundancy. These multiple projects enable the development a complementary and complete portfolio of technologies for multi-stream integrated biorefinery. It will also help to de-risk the technology development and improve the productivity and accountability.

ENZYME ENGINEERING AND OPTIMIZATION (TARGETED CONVERSION RESEARCH - RATIONAL DESIGN)

(WBS#: 2.5.4.100)

Project Description

The Enzyme Engineering and Optimization project targets technologies that ensure the DOE 2022 target of 10 mg cellulase/g cellulose is met. Our approach is to engineer improved glycoside hydrolase family 7 (Cel7A); however, the minimal existing genetic tools are a major barrier. We have determined the following: (1) some natural variants have higher activity than the *T. reesei* (industrial) enzyme, and better enzymes still reside in nature; (2) some of these enzymes may have expression problems in industrial hosts, but this can be overcome; and (3) we can describe on a structural level the biochemical function of cellulases.

Recipient:	National Renewable Energy Laboratory
Principal Investigator:	Mike Himmel
Project Dates:	10/1/2015-9/30/2018
Project Category:	Ongoing
Project Type:	AOP
DOE Funding FY 2014:	\$0
DOE Funding FY 2015:	\$1,600,000
DOE Funding FY 2016:	\$1,600,000
DOE Funding FY 2017:	\$1,600,000

Limited understanding of Cel7A processing in *T. reesei* restricts rational study of this enzyme. To address this challenge, we model cellulase action, design and build modifications, and measure performance. We are applying computational algorithms to a natural diversity library to parse out Cel7-specific codon usage to enable better heterologous expression.

Collaboration with PNNL's Environmental Molecular Sciences Laboratory is revealing how Cel7A is processed and trafficked in *T. reesei*, which should enable

Weighted Project Score: 7.9

Weighting: For ongoing projects, there is equal weighting across all four evaluation criteria: Approach, Relevance, Accomplishments and Progress, and Future Work.

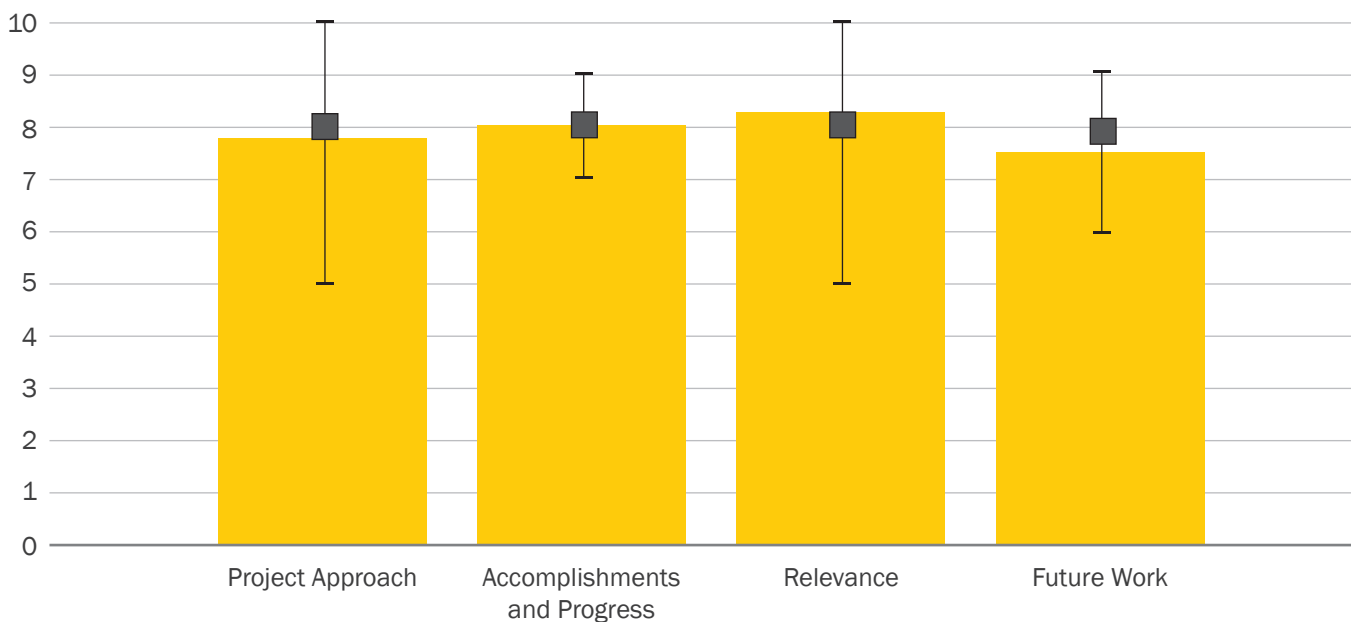

■ Project's average evaluation criteria score
 ■ Average value for evaluation criteria across all projects in this session
 Range of scores given to this project by the session Review Panel

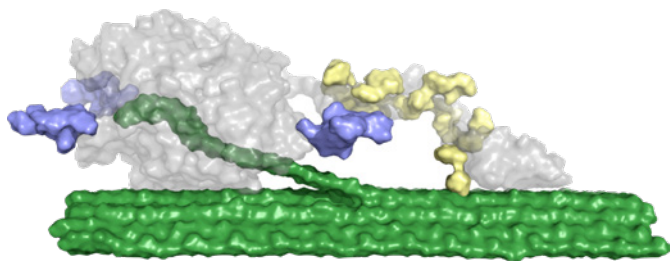

strain improvements. We also use our expertise to enhance metabolic pathways of advanced biofuels and products. We collaborate closely with Targeted Microbial Development to screen variants of pathway genes and hand off winners to Targeted Microbial Development for in vivo testing for increased product TRY. Our ability to generate enzyme activities across a range of levels means Targeted Microbial Development can balance enzyme rates to optimize metabolic flux.

Overall Impressions

- The project is built on the idea that detailed study of individual enzymes through basic research on structural biology will lead to improvements in industrial enzyme mixtures. The project has generated some scientifically interesting results (making the performance of the Tr Cel7A like that of the Pf Cel7A by swapping sub-domains, investigating the role of glycosylation sites in Cel7A activity and stability), but there is a weakness in closing the loop and demonstrating the performance of single enzymes and improved mixtures in deconstruction of pretreated biomass and in measuring expression of native and mutated variants in a relevant host.

There are significant opportunities for the project team to provide practical benefits to biorefinery and industrial enzyme companies: release of platform *T. reesei* strains for single enzyme production and advantaged cocktails; a comprehensive study on the benefits of codon usage optimization for synthetic genes in *T. reesei*; a broad survey of cellobiohydrolase 1 biodiversity and performance; and extension

of the study into enzyme compositions across the wide range of pretreated material to which NREL has access.

My main feedback would be to encourage the project team to consider in full the technical risks and benefits of a particular route early on (e.g., the risks of generating data that do not repeat in a production host versus the benefit of using an easier host, such as yeast). The benefits of throughput may not outweigh the risks of artifacts. Also, I think it is worth stepping back and considering the practical benefits that can be supplied to companies in the industrial biotechnology field through enzyme selection and production, versus what may be scientifically interesting results.

- The PIs have developed a highly interesting program to improve the generation of reactive cellulases and development of new cellulase systems for the production of sugars in the biorefinery. The work has clear industrial potential, and the team would benefit from including additional descriptions of this work's links to commercial application. The dots are all there, and just a little more time spent connecting them will really prove the utility of this work.
- The primary focus of the Enzyme Engineering and Optimization program is to develop better cellulase activity. Since this enzyme represents up to 25% of biorefinery cost, this is a very important task. One might think that after 10 years of active research, there is not room for significant improvement in cellulase activities. However, their results indicate that this is not the case and that there are several exciting avenues to more active and robust enzymes. In fact, given the relevance, it may be worth putting more resources on this work. Future targets are not well-defined. How much improvement are they targeting, both in the near term and long term?

A secondary objective is to aid metabolic engineering projects by improving enzymes that are critical to their success. There are also no quantitative targets set for these enzymes. This work must be closely managed to make sure it doesn't distract from the cellulase work. In the future, perhaps this should be two separate programs.

- The project history and relevance is of most importance to drive cost reduction of bioconversion technologies. The overall technical and management approach is sound and logical. Emphasizing the need for a publicly available chassis fungal strain is well-understood as a mitigation strategy and democratization of knowledge. Commercial viability appeared to be sound based on the TEA and industrial partners' testimonies. An opportunity to expedite even further is to focus a critical mass of resources on holistic development of this category (enzyme engineering, production host, separation, etc.). Another opportunity would be to do the metabolic pathway enzymes discovery at the individual teams or partnered with an academic laboratory for prospecting. The PI is already hinting for such in the event of a budget cut.

PI Response to Reviewer Comments

- We thank the Review Panel for the supportive comments and helpful feedback.

This is exactly our overall goal, and we would welcome any opportunity to work with producers to exploit these results and advances. Note that the yeast screening work was approached in exactly this way (i.e., a quick screen based on the new finding from Mascoma). We continue to strive to be introspective regarding our expenditure of resources and time when driving toward goals important to DOE and industry.

The Review Panel made a very good point regarding cellulase metrics, and we will clarify in future AOP planning. The challenge for us is that only the enzyme companies know what it costs to produce commercial cellulase formulations. We thus necessarily take the approach that improving the key component enzyme performance will always result in a reduction in cellulase cost, regardless of the exact production and formulation path taken by a particular company. The enzyme companies appear to agree that this assumption is valid. The observation that progress in Task 2 (metabolic enzymes) is not as strong as that in Task 1 (enzymatic hydrolysis) is due in part to the disparate respective funding levels. A second cause, explained in the oral presentation, is that the Task 2 work was recently initiated. In planning the FY 2016–FY 2017 AOP, we perceived a more urgent need to make progress in the cellulase arena; this decision can be reassessed for 2018.

LOW-ENERGY MAGNETIC FIELD SEPARATION USING MAGNETIC NANOPARTICLE SOLID ADSORBENTS

(WBS#: 2.5.5.100)

Project Description

We are exploring energy-efficient technology to improve process economics for separations of fuels and products. Nanostructured adsorbents (NA) produced using heterogeneous vapor-phase polymerization successfully adsorb target hydrocarbons. Tailored NA surface treatments enable adsorption of long-chain isoprenols with high affinity and specificity. The NA's capacity for hydrocarbon far exceeds their weight. The materials swell upon binding and have conditional properties that allow for facile removal from bioreactors. Magnetic and/or low-pressure, mechanical compression routinely releases >95% of the hydrocarbons adsorbed during a cycle. On the 10-L scale, NA has proven stable and reusable

Recipient:	Argonne National Laboratory
Principal Investigator:	Phil Laible
Project Dates:	7/25/2011-9/30/2018
Project Category:	Ongoing
Project Type:	AOP
DOE Funding FY 2014:	\$300,000
DOE Funding FY 2015:	\$300,000
DOE Funding FY 2016:	\$300,000
DOE Funding FY 2017:	\$300,000

for tens of cycles and has allowed economics to be compared at the 100-cycle level. Little, if any, materials are lost during each cycle. Current efforts focus on scaled syntheses using commercial production methods. Future NA advancements will focus upon expanding adsorption specificity to include a range of other products produced via biochemical conversion routes. As compared to current, commonly practiced solvent extraction and distillation methods, the costs associated with this novel approach can be much lower, especially as multi-cycle operations are proven. Applications for this process-in-

Weighted Project Score: 7.9

Weighting: For ongoing projects, there is equal weighting across all four evaluation criteria: Approach, Relevance, Accomplishments and Progress, and Future Work.

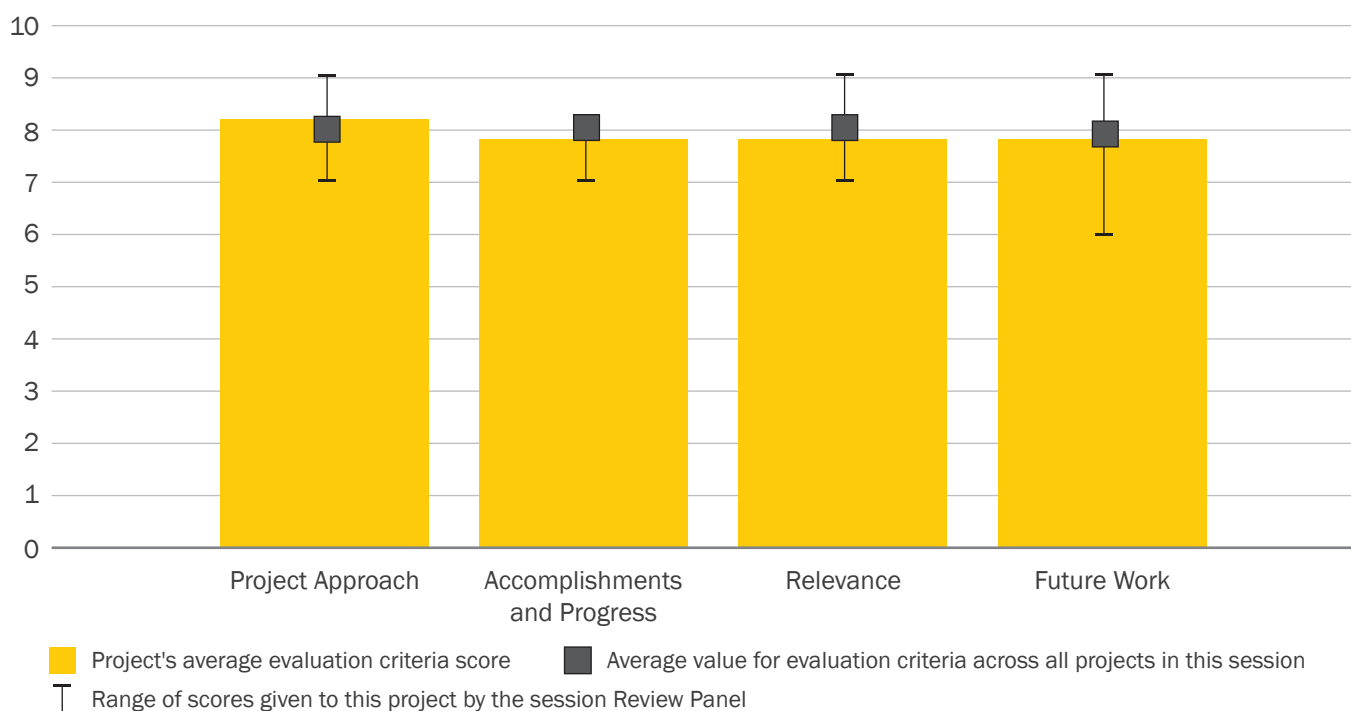

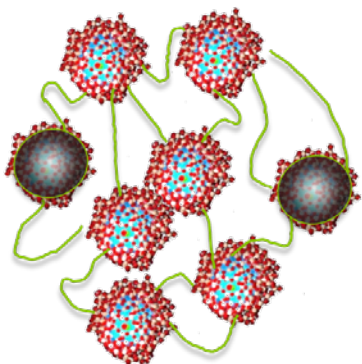

tensified approach are greatest for fermentation practices where products are exported into the culture medium and product inhibition is exhibited at low titer.

Overall Impressions

The project has put forward what looks to be a novel solution to the recovery of chemical or fuel products, with the possibility of also removing inhibitors.

The basic generation of material and down-selection to more economic versions looks good, with demonstration of high recovery rates over multiple rounds. The only concern I have is how the performance looks when applied to full-on process configurations (residual solids, complex mixtures of product, cells and pretreatment side products). It would be good for the team to select some of these from the BETO portfolio and see how the material plugs in to existing processes and process streams.

- The PIs have developed an interesting approach for separating hydrocarbon biofuel from a fermentation system. The economics are promising, and the process has been demonstrated at large scale. The project will benefit from testing the process on mixed hydrocarbons. The biggest challenge may be convincing industry that this method is preferable to more conventional separation methods currently in use.

- This program developed nonabsorbent particles for biofuel separation from the fermentation broth. This would enable removal at low concentrations in situ, preventing buildup of the fuel to toxic levels. The team generated a lot of results and met milestones. The method has the potential for large cost savings, but the particles themselves are currently too expensive. Efforts on new production methods were investigated, but they were trimmed so that effort could be focused on demonstrating separation efficacy.
- Separations projects like this have the potential to significantly reduce process costs and be game changers. This need is the basis for forming the Separations Consortium, which this project will join. Specific product removal, reduced inhibition, and continuous fermentation are very worthy goals and can be enabling across bioprocesses. This project did a nice job of leveraging previous work and down-selecting when the original particle was found to be too expensive. Economics and process integration of a new unit operation will be critical.
- This is a very good demonstration of skills and expertise deployed on the right target with a great potential for separation cost savings and upside potential for other projects, like protein separation.

PI Response to Reviewer Comments

- We thank the reviewers for their kind words. We have only one comment/presentation regret: We can see where the down-selection slide on magnetic nanoparticles did not clearly explain that, although these starting materials were abandoned, that we went ahead successfully with lower-cost, non-magnetic replacements that showed conditional properties (e.g., float or sink when binding a threshold amount of biofuel/bioprocess) that were just as good for bioreactor integration/processing as

magnetic-based operations. Thus, we have magnetic-type functionality of the adsorbents without the costs associated in their synthesis. We wish this portion of the talk could have been expanded (as it was in 2015). We just needed to justify the title of the project and how we moved away from magnetic starting materials (in 2017). It seems that four of the five reviewers understood this point, but it is now apparent that we could have been clearer in our description of the technology as it moves forward with lower costs.

SEPARATIONS CONSORTIUM

(WBS#: 2.5.5.501-508)

Project Description

The Separations Consortium aims to move cost-effective, high-performing separations technologies to market faster through coordinated research at the national laboratories that targets challenges relevant to industry and BETO's priority conversion pathways. It addresses BETO stakeholder feedback that separations technologies merit near-term R&D that will reduce biofuel and bioproduct production costs. After a study of separations challenges in BETO priority conversion pathways, the eight-laboratory consortium formed into five teams in the following areas: preserving biochemical catalysts and biochemical, thermochemical, algal, ionic liquid process-based separations.

A TEA and life-cycle analysis team provides technical teams insight into the economic and environmental effects of their work. A steering committee and an

Recipient:	Argonne National Laboratory, Idaho National Laboratory, Los Alamos National Laboratory, Lawrence Berkeley National Laboratory, Oak Ridge National Laboratory, National Renewable Energy Laboratory, Pacific Northwest National Laboratory, Sandia National Laboratories
Principal Investigator:	Jennifer Dunn
Project Dates:	5/1/2016-9/30/2019
Project Category:	New
Project Type:	AOP
DOE Funding FY 2014:	\$0
DOE Funding FY 2015:	\$0
DOE Funding FY 2016:	\$500,000
DOE Funding FY 2017:	\$3,000,000

industrial advisory board provide guidance. The consortium's future work includes conducting research to enable cost-effective separations relevant to lignin

Weighted Project Score: 8.1

Weighting: Approach-25%; Relevance-25%; Future Work-50%.

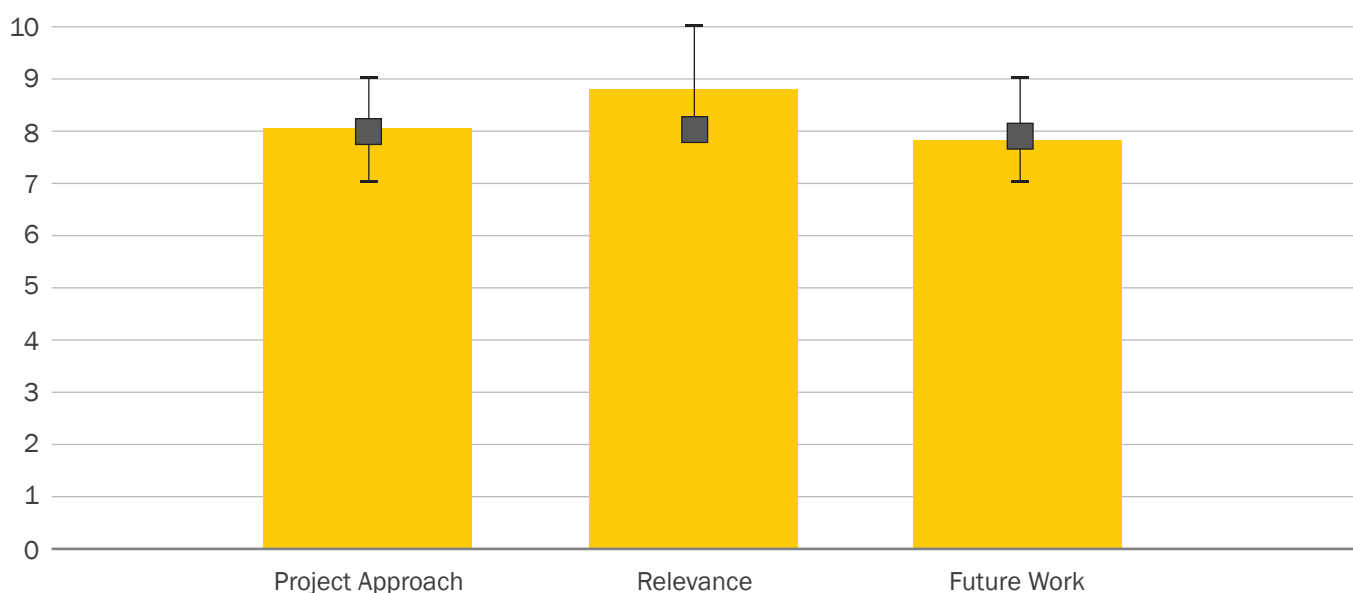

■ Project's average evaluation criteria score
 ■ Average value for evaluation criteria across all projects in this session
 Range of scores given to this project by the session Review Panel



valorization and fermentation product target recovery, increasing thermochemical catalyst lifetimes through removing contaminants, using ultrasonic processing and membranes to improve efficiency of dewatering in algal processes, and using tailor-made materials to selectively adsorb toxins in fermentation. The consortium, currently in its second quarter, has met with its industrial advisory board and gathered feedback regarding current projects and future direction.

Overall Impressions

- The core concept for the consortium is very solid. This seems like exactly the type of work that represents a good use of public funding—addressing central problems faced by industry for which solutions can enable further cost-effective development work. The structure allows the different national laboratories to contribute to each other’s sub-projects and share ideas and knowledge, without being so codependent that the work is slowed down.
- The consortium has the potential to be a valuable addition to the BETO portfolio, but it would be greatly strengthened by a stronger justification for the specific separation technologies chosen for investigation. Leveraging the strengths of the partner laboratories is important, but the choice must be coupled with a rationale describing how and why some technology will be better than other, less-expensive or exotic approaches.
- Separations research has historically not been a major part of biotechnology research, though it is a critical component of a cost-effective biorefinery. The Separations Consortium brings together experts from various locations and focuses research on the most high-priority separation challenges that

The consortium looks to be well-organized and appropriately structured and has taken an excellent approach in using the expertise already present in the national laboratories in identifying key process problems relevant to producing biofuels and renewable chemicals from non-food feedstocks and potential solutions to be evaluated. There are real prospects here for the group to put forward and develop process solutions that can make the biology or catalytic chemistry being developed more economically viable.

An important aspect will be interaction with the outside world. It is certainly useful to have an industrial advisory board, and there will undoubtedly be additional outside companies that can either give useful information on alternative technologies and materials or provide new requests for technology development opportunities, so it will be good to make sure the consortium maintains an outreach effort to essentially advertise its efforts. Providing a well-publicized website with information and a route to interacting with the group is a great idea. It will be useful to monitor the effectiveness of the website in disseminating information and encouraging engagement and to get feedback whenever possible.

will provide the most cost benefit. As separations accounts for 25%–50% of bioprocessing cost, this work is essential to meeting BETO’s cost targets. The team took a systematic approach to identifying relevant projects by finding the key challenges in various conversion pathways. They engaged industry experts (and will continue to do so) and coordinated with other BETO programs to ensure the continued relevance of their work. Managing such a large, diverse portfolio of activities may be a challenge. However, the team came up with a great idea to have “stream stewards” to make sure there is consistency in the feedstock or product streams provided to each group for the lifetime of the project.

The team has made good progress in the short time they have been active, and they have a well-defined roadmap for the future. In their approach, the team is looking at novel technologies that will provide more than just an incremental improvement in performance and cost reduction. However, some of these approaches are high-risk, and no contingency plans are given.

- The presentation was well-organized and delivered. The planned work of this consortium is aligned with MYPP goals and has the potential to make real improvements to BETO-funded bioprocesses and enable industry cost reduction through improved efficiency. The target selection approach seems very well-considered. SMART goals are recommended for all separations projects, with multiple opportunities for success. This is a key work stream, and I look forward to following the progress of this consortium!
- This is a great initiative, and I am looking forward to seeing how this important topic is implemented and embedded in every project. It is essential and, in my experience, if taken seriously, can either make or break projects, which should be the case before launching any project in the future.

PI Response to Reviewer Comments

- We thank the reviewers for their many positive comments regarding the relevance and importance of this effort to BETO and to industry and regarding the organization and approach of the consortium. We are looking forward to technical progress within the consortium and continued and expanded interactions with industrial stakeholders.

In overall comments, reviewers highlighted the need for exterior engagement. The project team is extremely committed to working with industry, as well as other researchers. Collecting input from these stakeholders was a key driver of the industry listening day scheduled in May 2017, as well as ongoing interactions with our advisory board, which provides feedback on the consortium’s current portfolio, research progress, relevance to industry, and plans for future work.

Reviewers noted the need to justify technology choices, especially the rationale behind working with a less-common technology rather than conventional technology. To address this comment, the consortium will continue to use TEA and quantitative metrics to evaluate the technology progress and to underpin the Separations Consortium’s project portfolio.

Finally, reviewers noted the importance of key project management elements, including SMART milestones and contingency plans. The team is very committed to robust project management, with BETO’s support. Risk and associated mitigations, along with SMART milestones, are included in the AOPs of every participating laboratory. We appreciate the feedback to highlight these success criteria more broadly. In addition, each team has go/no-go decision points. The team will pursue timely and robust decision making and prioritization of efforts based on laboratory-based performance data and TEA. If a process or technology does not appear to address critical process economic gaps in an efficient manner, the team is structured to re-focus on other efforts.

ADVANCED BIOFUELS PROCESS DEMONSTRATION UNIT (ABPDU)

(WBS#: 2.6.1.101)

Project Description

The ABPDU was established to provide scale-up and commercialization services to the biofuels and bioproducts community, including industry, academia, and the national laboratories. This AOP project covers expenses related to facility readiness, process benchmarking, and business development. While, generally, ABPDU partners and customers pay for the incremental costs associated with the work they do at this facility, this base budget is required to operate the facility in a not-for-profit, work-for-others model. The partnerships enabled by this BETO-supported model allow advancement of key technologies from early stages to deployment in industry, bringing value to the entire biofuels and bioproducts community and providing high-visibility examples relevant to the BETO mission.

Recipient:	Lawrence Berkeley National Laboratory
Principal Investigator:	Todd Pray
Project Dates:	7/13/2010–9/30/2017
Project Category:	Ongoing
Project Type:	AOP
DOE Funding FY 2014:	\$2,750,000
DOE Funding FY 2015:	\$2,740,000
DOE Funding FY 2016:	\$2,750,000
DOE Funding FY 2017:	\$2,500,000

In order to provide cutting-edge technical services and process development expertise, the ABPDU will repeatedly baseline its processes to ensure team training and robust performance across all unit operations, from deconstruction through fermentation, separations, purification and analytics. The ABPDU will also maintain and upgrade its physical plant to offer access to technologies, processes, and analytics in demand by its clients, whether using small-scale process optimization capabilities or scaling up to the 300-L fermentation suite and/or the facility's 100-L biomass deconstruction and chemical catalysis capacity.

Weighted Project Score: 8.4

Weighting: For ongoing projects, there is equal weighting across all four evaluation criteria: Approach, Relevance, Accomplishments and Progress, and Future Work.

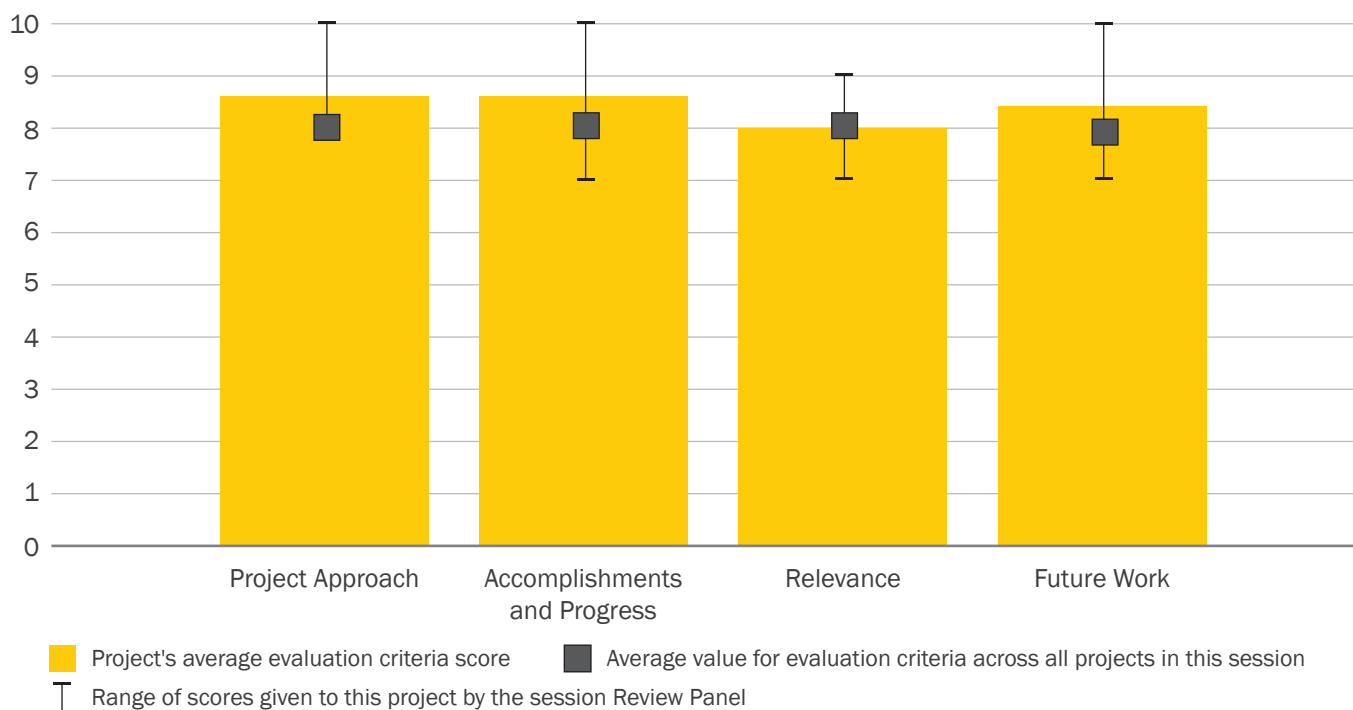



Overall Impressions

- I have to say, I'm really glad something like the ABPDU exists. It seems to fulfill an important role in helping small innovative companies test out ideas and materials while minimizing the amount of investment they may need to make in equipment. Just looking at the client list shows the impact that the unit has. It is important to think more broadly about the growing bioeconomy than biofuels alone, and ABPDU can help move forward some of those more innovative ideas about uses for sugars and ways to reduce greenhouse gas emissions.

Although there is some overlap in scale and perhaps some technologies with NREL, the ABPDU seems to fill a different niche. Certainly, companies should be able to decide which facility they want to work with, and the location in the California Bay Area opens up a different set of collaborations than a location in Colorado, given that process development is a fairly hands-on operation. It does make sense, though, for the ABPDU to be connected to the Agile BioFoundry and Separations Consortium, to make sure the ABPDU can provide another option for the output of those groups, in terms of either platform strains or new processes.

Personally, I'm not convinced that the ABPDU should aim to reduce its funding from BETO to zero right away. The overall return on investment looks pretty good in helping small companies move

forward, often at a critical time in their life cycle when technology needs to be proved out, but capital for investment in expensive fermentation and processing equipment may be limited. Within BETO's portfolio, this looks like a very good use of funding.

- The existence of larger-scale facilities within the BETO system is important, as they provide a centralized outlet for industry to come in and validate their operations. The ABPDU has had success generating business for their facility and also in reducing costs to BETO. However, their interaction with other larger-scale facilities within the program (NREL's Process Development Unit and NREL bench scale) seems limited or nonexistent, to the point that it appears more competitive than collaborative. It would streamline operations if these valuable facilities were more coordinated and had a single point of contact to help guide potential customers to the most appropriate facility for their needs.
- The ABPDU provides scale-up and commercialization support for a variety of projects relevant to the bioeconomy. Their services include all aspects of bioconversion, from biomass to pure product. Over the last few years, it has grown into a state-of-the-art facility that provides high-quality work and supports commercialization of industrial processes. The center has managed its projects well using an agile management system for resource allocation, enabling an impressive number of projects to be com-

pleted with a modest size team. A possible activity for the future is to work with the NREL Integrated Biorefinery Research Facility to determine which is most suitable for which type of project, enabling the best use of resources. Potentially, completed projects at the ABPDU can then move to the NREL facility for larger scale.

- This group has been quite successful enabling industry partners to optimize processes and scale and move bioprocesses towards commercialization. BETO has several mechanisms for funding small business ventures, and the ABPDU is a valuable incubator resource from process demonstration through technology transfer. ABPDU facilities and staff are versatile, having worked on bioprocesses to make chemicals, materials, biomass, and protein products. Initiating a system of project coordination with other pilot facilities (e.g., NREL) in the national laboratory system is highly encouraged.
- This is a nice effort to establish another pilot facility (closer to where it is needed) to enable small businesses and national laboratories with quicker and cost-effective turnaround on their small-scale fermentations. This is a very nice accomplishment in onboarding new projects and methods to enhance the customer and project team needs (e.g., auto sampler, high-throughput analytics, etc.). Also, there are great testimonies from customers, which I hope triggered the backfilling of projects to have this facility operate as a cash-neutral or minimally subsidized entity. The top challenges are keeping abreast with the technology and having skilled experts to operate, which the PI seemed to nicely establish. Cross-talk with the other pilot plants, bench-scale validation, and analytics seem to be gaps where the PI and BETO are encouraged to facilitate better in the future with good handover of protocols, techniques, etc. Overall, this project has made good progress and is on the right track to fulfill BETO's goals.

PI Response to Reviewer Comments

- The ABPDU team appreciates the positive feedback from the reviewers on our process development, scaling, and piloting work with industry and national laboratory partners. We've been very focused on process flexibility, training, sound project management, and overall organization and leadership development for the team, and this has allowed us to successfully execute efforts with 30 companies over the past 3 years or so and play a role in developing commercial processes that have been successfully launched. We've also been able to participate, drive, and contribute meaningfully to several BETO consortia projects, such as the Co-Optimization of Fuels and Engines, the Separations Consortium, the Agile BioFoundry, and the Feedstock-Conversion Interface Consortium.

A very helpful suggestion from several reviewers is that the ABPDU should coordinate more closely with specific facilities and groups, such as the Pilot-Scale Integration team at NREL's Integrated Biorefinery Research Facility, as well as the Bench-Scale Integration and Analytical Development and Support project groups at NREL. We're very committed to this and see a lot of value in doing so. We've been very proactive and focused on project and business development with industry partners; a number of them have already gone on to work with the Integrated Biorefinery Research Facility at NREL and the pilot-scale algae cultivation facilities at Sandia National Laboratories in Livermore, for example, using shared project plans under the Office of Energy Efficiency and Renewable Energy's Small Business Vouchers program. It is one of our key goals to help companies transition to larger-scale facilities, and we actively help them in transferring technology following development of robust processes at the ABPDU.

Working with BETO and our partners at other national laboratory scale-up capital research assets, we are planning to develop a request for information to solicit feedback and input on existing and new capabilities that would be useful for industry stakeholders as they scale up and commercialize their technologies. The collective funding for all these shared resources at the national laboratory allows each team to complement the others while also providing a unique value proposition to their academic and industry partners.

To conclude, the national laboratories and BETO have an opportunity to more clearly articulate and better communicate the resources available at sites

such as the ABPDU at Lawrence Berkeley National Laboratory and the Integrated Biorefinery Research Facility at NREL. This will allow companies and other potential users to quickly find the most suitable team and facility to meet their needs in terms of scale, technical capabilities, location, and process expertise. The ABPDU will do what we can to ensure that the collaboration between national laboratories remains strong, to best enable BETO's goals and the technology developers in industry that are making great progress in growing the bioeconomy for biofuels, biobased chemicals, proteins, and materials that will spur our domestic manufacturing base, create jobs, and leverage the abundant natural resources inherent in biomass.

IMPROVING TOLERANCE OF YEAST TO LIGNOCELLULOSE-DERIVED FEEDSTOCKS AND PRODUCTS

(WBS#: EE0007531)

Project Description

Combined substrate-product toxicity in microbes is one of the major constraints hampering the scale-up and economic competitiveness of bioprocesses based on lignocellulosic feedstocks. Hydrolytic pretreatments of biomass release numerous compounds impinging on cell viability; the three most significant to yeast (the industry dominant biocatalyst) and common to all plant sources are furfural, hydroxymethylfurfural, and acetic acid. Furthermore, the desired end product, such as ethanol, typically attacks a multitude of host cellular functions via mechanisms yet to be fully understood.

We propose to enhance lignocellulosic fermentations in yeast using nutrient adjustments proven previously to

Recipient:	Massachusetts Institute of Technology
Principal Investigator:	Dr. Greg Stephanopoulos
Project Dates:	10/1/2016–9/30/2019
Project Category:	New
Project Type:	FY 2015–BRDI
Total DOE Funding:	\$1,500,000

boost alcohol tolerance, combined with genetic modifications aimed at alleviating hydrolysate toxicity. First, we will systematically characterize the component toxicities in biomass hydrolysates and quantify their relative impacts on ethanol production. Subsequently, we will engineer tolerance to these inhibitory compounds using strategies combining enzymatic detoxification with specific chemical modification of the fermentation medium. Finally, we will assess the extent to which these tolerance methods are transferrable beyond ethanol production, specifically, to yeast processes synthesizing the antifreeze precursor monoethylene glycol.

Weighted Project Score: 8.1

Weighting: Approach–25%; Relevance–25%; Future Work–50%.

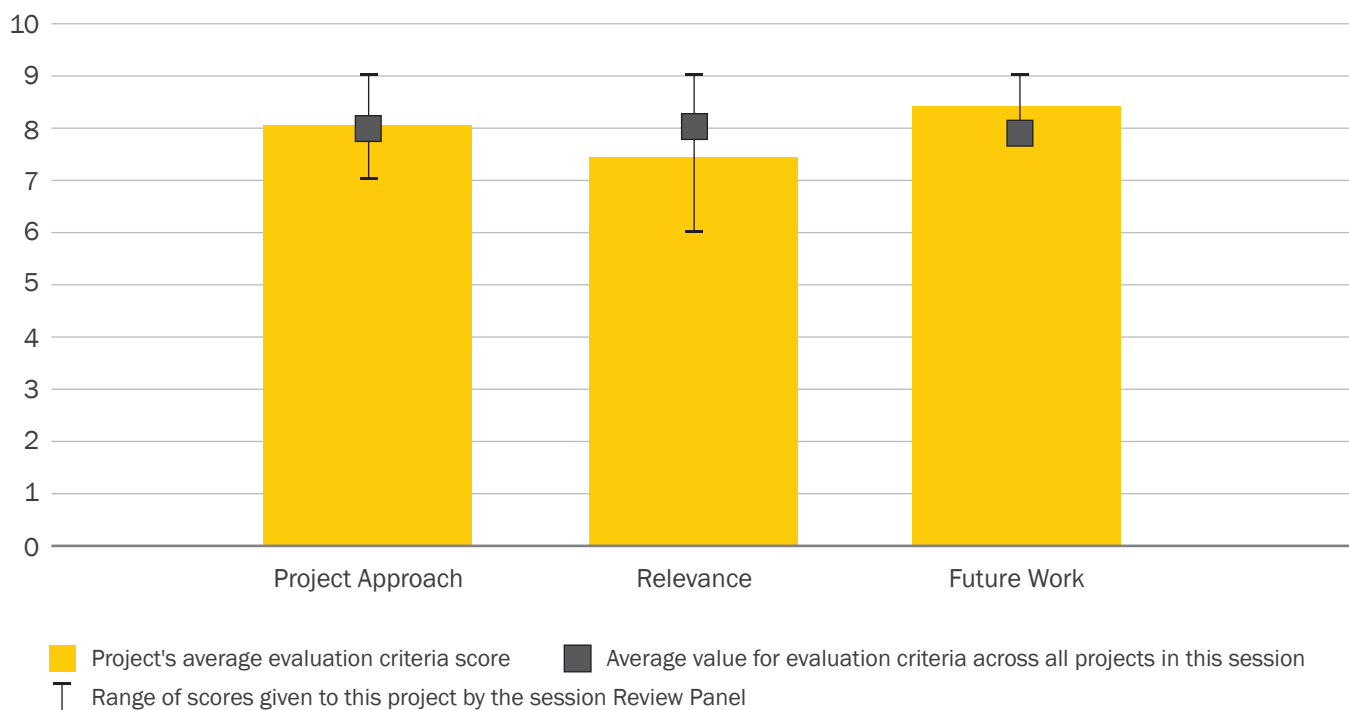

Overall Impressions

- The project addresses a serious difficulty, and often a technical weakness, that limits many production systems using lignocellulosic hydrolysate streams. Use of these sugar streams with the attendant inhibitors is a lot different than using clean sugar streams, such as sucrose or glucose from starch, and places a major physiological burden on the cell. It would be very good for the Massachusetts Institute of Technology group to fully address the nature of the damage that the inhibitors cause (individually and in combination) and to identify mitigation strategies that allow higher concentrations of sugar streams to be used, or more severe pretreatments, and reduce the metabolic burden on the cell (hence improving yields).

The project team seems to have a very good understanding of what they want to do and have presented a fairly clear, well laid out plan.

- This is an early-stage project with little information on which to base an evaluation. However, the approach is based on strong publications from the PI. More detailed evaluation will need to wait for initial results to come in.
- This project leverages experience and knowledge base at Massachusetts Institute of Technology for engineering microbial tolerance to develop *S. cerevisiae* strains with improved tolerance to inhibitors present in biomass hydrolysate. The relevance is clear, but the team should have more guidance from industry to make sure they are addressing the right factors. The approach is straightforward, and the team's history inspires confidence in achieving success. Ethylene glycol production target is achievable, but since there is no proof of concept so far, it could present unknown challenges.

- The project is testing a membrane-based general tolerance mechanism for ethanol in a strain that will also be able to convert toxic compounds in biomass hydrolysate to alcohols. This detoxifying and ethanol-tolerant strain has the potential to reduce bioconversion process cost with respect to detoxification. It is not clear to me how many in the industry are still practicing detoxification, nor whether the membrane-based tolerance mechanism is combinable with previous progress made in yeast ethanol tolerance.
- Overall, it is an ambitious goal to capitalize on novel molecular tools to enable higher tolerance of yeast strain to inhibitors present at lignocellulosic sugars for producing ethanol and monoethylene glycol. These products are commodities, and as such, the economic feasibility of the project should be evaluated thoroughly in the near future. Nonetheless, as technical advancement in understanding of yeast tolerance enables the academic and the national laboratories, a community with more knowledge in this field could be an advantage. If, in the end, Biochemtex or any other partner will license this to be used in the lignocellulosic ethanol domain as an economically superior strain, then BETO has accomplished its mission. If monoethylene glycol can be produced economically later from C5 sugars as biobased chemicals to enable hydrocarbon biofuels in an integrated biorefinery, that is even better.

PI Response to Reviewer Comments

- Most of the comments have been addressed in the previous sections. Overall, despite some differences in the approach with industry, we concur that more interaction can only help with keeping our goals grounded and relevant. We look forward to cultivating stronger connections as this project progresses.





WASTE TO ENERGY



TECHNOLOGY AREA

CONTENTS

INTRODUCTION	464
WTE OVERVIEW	464
WTE REVIEW PANEL.....	465
TECHNOLOGY AREA SCORE RESULTS.....	466
WTE REVIEW PANEL SUMMARY REPORT	467
WTE PROGRAMMATIC RESPONSE	472
WTE SIMULATION MODEL.....	474
WASTE-TO-ENERGY: FEEDSTOCK EVALUATION AND BIOFUELS PRODUCTION POTENTIAL.....	476
HYDROTHERMAL PROCESSING OF BIOMASS	479
ENHANCED ANAEROBIC DIGESTION.....	481
LACTIC ACID-PRODUCING METHANOTROPHIC BACTERIA FOR FERMENTATION OF BIO-METHANE AS A BIOLOGICAL UPGRADING TECHNOLOGY	484
BIOMASS ELECTROCHEMICAL REACTOR FOR UPGRADING BIOREFINERY WASTE TO INDUSTRIAL CHEMICALS AND HYDROGEN-BCU ALT	488
BIOGAS TO LIQUID FUELS AND CHEMICALS USING A METHANOTROPHIC MICROORGANISM	490
BIOGAS VALORIZATION: DEVELOPMENT OF A BIOGAS-TO-MUCONIC ACID BIOPROCESS	493
ELECTROCHEMICAL MONITORING OF ANAEROBIC DIGESTION.....	496

INTRODUCTION

In the Waste-to-Energy (WTE) session, four external experts from industry and academia reviewed a total of nine projects.

This review addressed a total U.S. Department of Energy (DOE) investment value of approximately \$18,733,224, which represents approximately 3% of the Bioenergy Technologies Office (BETO or the Office) portfolio reviewed during the 2017 Project Peer Review. During the Project Peer Review meeting, the principal investigator (PI) for each project was given between 15 to 30 minutes (depending on the project's funding level and relative importance to achieving BETO goals) to deliver a presentation and respond to questions from the Review Panel.

The Review Panel evaluated and scored projects for their project approach, technical progress and accomplishments, relevance to BETO goals, and future plans. This section of the report contains the results of the project review, including full scoring information for each project, summary comments from each reviewer, and any public response provided by the PI. This section also includes overview information on the WTE Technology Area, full scoring results and analysis, the Review Panel's summary report, and BETO's programmatic response.

The WTE Technology Area review had several BETO contributors. Andrea Bailey was responsible for all aspects of review planning and implementation, and David Babson was responsible for session facilitation.

WTE OVERVIEW

Wastes present a unique set of challenges for conversion processes, and BETO is exploring conversion possibilities at a wide variety of technology readiness levels (TRLs). Municipal, industrial, and agricultural wastes—as well as gaseous wastes, including carbon-rich industrial emissions, stranded natural gas, biogas, and even low-concentration carbon oxides recoverable from environmental systems (atmosphere or aquatic systems)—are potentially high-impact resources for the domestic production of fuels, products, heat, and electricity. Unlike traditional terrestrial bioenergy crops or algal biomass, waste resources are generated continuously as a byproduct of human activity. Established costs for managing wastes and mitigating associated harms present unique opportunities to avoid such costs and harms while generating valuable fuel, energy, and products.

Identified wastes and waste streams are broadly diverse and heterogenous. Given waste's inherent diversity and heterogeneity, distributed accumulation, and regulated and varied management requirements, one cannot

adequately equate waste management and conversion technologies to other biorefining or biofuel production systems. For these reasons, BETO has begun considering the challenges and opportunities associated with waste feedstock, conversion, and advanced development and optimization independently. BETO discusses and considers waste valorization and management technologies separately in order to promote appropriately tuned technologies and design strategies for managing diverse waste inputs and for addressing unique challenges not encountered during traditional biomass handling. This approach provides an opportunity for better strategic planning and more useful, targeted research and development (R&D) investments in this space.

BETO is considering hydrothermal processing techniques as a more established conversion technology option. These efforts have benefited from prior funding under BETO's Advanced Algal Systems and Conversion R&D Program Areas. Research indicates that these and related technologies could process diverse blends of wet waste feedstocks, offering potential for widespread de-

ployment. BETO's hydrothermal liquefaction efforts so far represent only a small part of the possibilities in this area; supercritical water also offers intriguing options, as do other fluids at high temperature and pressure, such as carbon dioxide (CO₂).

Several other conversion technologies are under investigation for both wet and gaseous waste feedstocks. Anaerobic digestion (AD)—a series of biological steps where microorganisms break down organic material in an oxygen-free setting to produce biogas—has

the potential to become a widely used bioconversion process. Similarly, arrested methanogenesis, anaerobic membrane reactors, and various pre- and post-treatment strategies all appear to have promise. In terms of gaseous resources, thermochemical, biochemical, and electrochemical strategies all have some merit, as do various combinations of the three. It seems clear that exploring a broad range of possibilities, followed by a rigorous down-selection process, has a good chance of producing market-relevant platforms.

WTE REVIEW PANEL

Name	Affiliation
Lucca Zullo*	VerdeNero LLC
Phil Marrone	Leidos
Brandon Emme	ICM Inc.
Jeremy Guest	University of Illinois at Urbana-Champaign
Mark Yancey	BBI International

*Lead Reviewer

TECHNOLOGY AREA SCORE RESULTS

Average Weighted Scores by Project

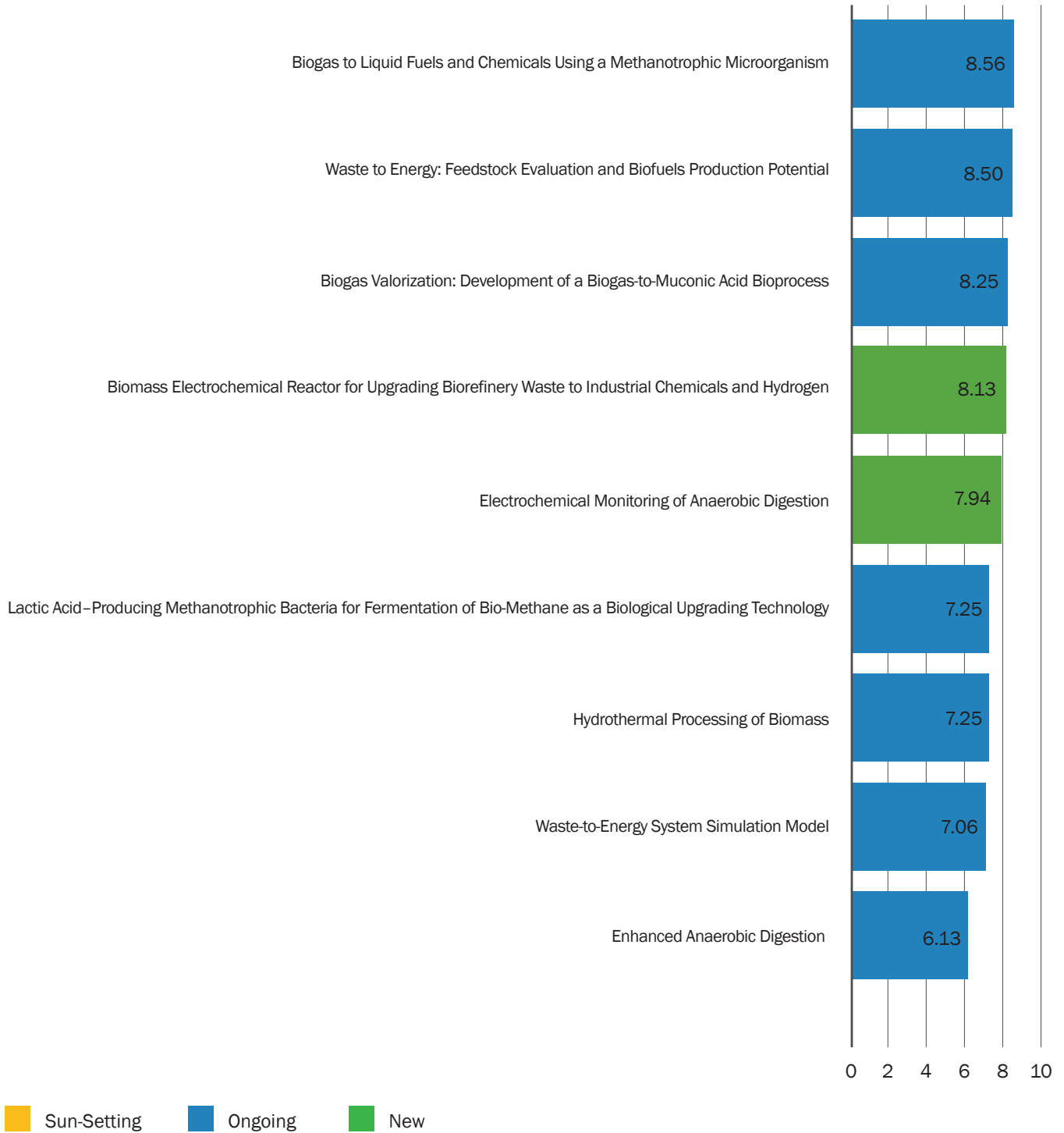

WTE REVIEW PANEL SUMMARY REPORT

Prepared by the WTE Review Panel

Introduction

This report is intended to provide high-level, general comments to the BETO program managers to guide and help them focus their WTE activities and increase the return on the public investment. This report does not intend to reconcile the opinions of the individual reviewers nor to discuss in detail specific projects; it aims to capture general themes, ideas, and observations and, where relevant, highlight different views. References to specific projects are present when the consideration has relevance for the whole programmatic area. Detailed project comments, especially those that are technical in nature and address specific issues of individual projects, are in the individual project reviews. The individual project reviews are and should remain the primary reference in judging the individual projects.

WTE is a relatively new area for BETO. As such, it includes projects that originally may have been part of other programmatic areas. It is the unanimous opinion of the Review Panel that the introduction of the WTE Technology Area is consistent with BETO's larger mission and is a welcome addition to the portfolio. As a new area, it also lacks some level of definition. Such unclear definition is not unexpected, and it was our intent to point out these issues when apparent in the project reviews. The Review Panel's aim is to help the BETO program and technology managers to improve the scope and definition for the WTE Technology Area. We advocate for WTE to remain part of the BETO portfolio with an expanded array of projects. The Review Panel, while mostly consistent in assessing the relative merits of individual projects presented, has also sometimes provided very different evaluations of individual projects. When relevant to an overall assessment of the programmatic area, specific aspects of individual projects may be discussed.

As a general observation, the need to maintain each presentation within reasonable time limits may sometimes make it difficult to convey results, methods, and project context adequately. The PIs' responses to the reviewers' comments make it clear that some of the gaps we have identified were known to PIs. The reviewers' perception was amplified by the presentation format and the relatively short time allowed to present complex projects. We feel that there are a few areas where the presentations could have been improved by a template to support a more cohesive assessment, namely the following:

- It would be beneficial to always have a table that, when applicable, shows targets versus achievements to date—to have an immediate assessment of whether the goals were achieved or not and by which margin the goals were missed or surpassed. No explanation is needed, as this can be addressed in another part of the presentation and in the Q&A with the reviewers.
- We would benefit from a clear summary of assumptions with respect to TRL and techno-economic analysis (TEA). During the review, it was often clear that the panel members and the presenters were not aligned on these assumptions. Such an alignment often did not occur during the discussion and emerged more clearly only when PIs responded to the panelists' comments.

Impact

The WTE Area has been established to identify opportunities for “wet” and low-bulk-density streams, which will not be suitable for technology aimed at more conventional biomass sources. These include sludges from wastewater treatment plants (WWTPs), manure, and food waste. The United States has much infrastructure, which can be leveraged for WTE both in the large number (exceeding 15,000) of WWTPs in the United States and an extremely developed agricultural sector with significant concentrated animal feeding operations producing a large amount of manure. Today, only a frac-

tion of that manure is captured for biogas production. In the case of wastewater treatment, a large distributed infrastructure is available. In the context of WTE, we should not ignore municipal solid waste (MSW). MSW is not a “wet” stream in the way the others are, but it is a considerable source of cellulosic material, as recognized in other BETO programmatic areas. Given the interest that MSW is raising as a carbon source for biorefineries and its recent inclusion in the *2016 Billion-Ton Report: Advancing Domestic Resources for a Thriving Bioeconomy*, we expect that, in the future, MSW will be directly included in the WTE Technology Area—especially unsorted MSW, which is poorly suited as a source of refuse-derived fuel and is sent to a landfill. Key technologies addressed by the WTE Area, such as AD and hydrothermal liquefaction (HTL), can certainly use the organic fraction of MSW as a feedstock. We therefore consider MSW a natural extension of the scope of the Conversion Program Area.

WTE feedstocks have some characteristics in common: they are highly distributed, are ubiquitous, and can provide significant contributions at the local level. They are also unsuitable for transportation, which limits aggregation and, consequently, the scale of projects. Hence, the local and distributed component of any solution is essential. In this area, the Review Panel reached a consensus that projects such as Waste-to-Energy: Feedstock Evaluation and Biofuels Production Potential can be highly impactful, as confirmed by the scores awarded. The value of inventory tools—especially when enhanced by Geographic Information Systems—to the practitioners cannot be underestimated. We strongly feel that this area is one where the national laboratories can provide unparalleled leadership by developing tools and methods accessible to the larger community of researchers, engineers, and project developers. The WTE Simulation Model, while having the potential to achieve a similar impact, was considered lacking adequate granularity for such distributed feedstock infrastructure. We do, however, encourage continuing the effort while

refocusing on a more bottom-up approach, as discussed in the specific project reviews. Ultimately, it was the Review Panel’s view that system dynamics models can be a valuable support tool for the industry.

While WTE feedstocks exist in already-developed supply chain infrastructures that provide known and predictable economics, these feedstocks are also often highly regulated. The tight regulation and the mission-critical nature of some of these facilities—such as WWTPs—fosters a cautious operating culture that is skeptical of change. These aspects—the highly regulated nature of the industry and the culture that it fosters—need to be considered, as they raise the bar for the adoption of novel technologies, especially when it may impact the facility’s core mission. An example of this is seen in the project, Hydrothermal Processing of Biomass. It is our view that the assumption to integrate the HTL recycle water into the front end of the WWTP—discussed in detail in the project review—will require careful assessment, as it may not be compatible with the needs of plant operators. This want in integration analysis, in turn, may limit or delay the positive impact of an otherwise very promising. Lastly, any advancement in AD technology and biogas utilization can spur the further development of biogas resources, which are currently substantially underdeveloped. The strong focus on biogas in a variety of projects is of clear value and impact. Technologies that allow whole-carbon utilization—methane and CO₂—of biogas can be particularly impactful here, as highlighted in the Biogas Valorization: Development of a Biogas-to-Muconic Acid Bioprocess project and projects that develop novel tools to improve the operations of digesters (as in Electrochemical Monitoring of Anaerobic Digestion). We commend the intent of Enhanced Anaerobic Digestion, which is in principle very aligned with the goals of this programmatic area. Regrettably, the project falls short of expectations for reasons discussed in the project review. The area addressed remains one of importance, and we hope it may be better addressed in the future.

Innovation

Projects leading to enhanced/improved AD and use of biogas for added-value products show substantive potential benefits. This is also an area where considerable innovation is needed and can be achieved. The projects *Biogas to Liquid Fuel and Chemicals Using a Methanotrophic Microorganism*, *Biogas Valorization: Development of a Biogas-to-Muconic Acid Bioprocess*, and *Lactic Acid-Producing Methanotrophic Bacteria for Fermentation of Bio-Methane as a Biological Upgrading Technology* indicate the opportunities and challenges of using biogas as a feedstock for bioprocessing. While these projects largely focus on metabolic optimization of specific organisms, they have already identified possible innovative solutions in reactor design. Bioreactor design advances are needed to address the unique challenges of biogas fermentation with respect to mass and heat transfer. Addressing these challenges in turn makes it possible to identify the optimal scale at which biogas can be economically used for these processes. We can already infer that these future bioprocessing facilities are necessarily limited in scale, and the transportation of suitable feedstock to larger ad-hoc biogas facilities is most likely economically unfeasible. The Review Panel was intrigued by the concept of a falling film reactor built with low-cost material, which is proposed in one of these projects. If successful, the combination of an optimized microorganism for biogas utilization with low-cost, scalable reactors that achieve high mass and heat transfer without considerable energy inputs would be a game changer for the industry. We feel this is one of the most significant innovations that could emerge from this program. Overall, we feel that whole biogas (both methane and CO₂) and raw biogas (biogas and contaminants other than CO₂) utilization is a critical area of innovation.

While AD is an old technology with plenty of industrial applications, it is still fundamentally rooted in empiricism, and we still have a limited understanding and an even less-effective way to control the behavior of

large microbial consortia on highly complex substrates. Control of biogas systems is largely reactive, using biogas production as the main measure of performance. In systems with very slow dynamics—and, in many cases, also clear anisotropy—the record of dropping gas production is an indication of an already severely compromised system. New monitoring and control techniques that improve AD system control may in turn improve AD economics and flexibility. For this reason, the Review Panel appreciates the *Electrochemical Monitoring of Anaerobic Digestion* project. Simple, inexpensive monitoring techniques and devices that can provide a more direct indication of the performance of the digester will enable better control and, therefore, utilization of existing AD assets. These techniques also promise to be a key enabler for the development of other digestion processes, which would greatly enrich this programmatic area.

Extracting value higher than the energy value of the stream of lignin derived from biorefinery operations has long been one of the industry's most elusive goals. The approach presented in *Biomass Electrochemical Reactor for Upgrading Biorefinery Waste to Industrial Chemicals and Hydrogen* shows an example of innovation of which we hope to see more in the future. While, at this time, the scalability of the solution is not yet clear and there are several uncertainties on the eventual commercial feasibility, the approach was mostly promising. In particular, the idea to target existing products and exploit the wet lignin as is, rather than extracting a specific chemical, could be a key enabler for commercialization. The PI on the project should be commended for the project's strong collaboration with the private sector. This project demonstrated the importance of early-stage involvement of commercial stakeholders.

Synergies

Considerable publicly and privately funded R&D efforts exist around methane utilization. Given the cost and availability of natural gas, interest in methane as a car-

bon source is high. The synergies between methane and biogas utilization are evident, although biogas imposes unique challenges due to methane dilution, contaminants, and limited scale. This synergy has two dimensions. On one side, it should push the R&D focus on WTE towards biogas-specific topics, such as the impact of CO₂ dilution or biogas-specific contaminants. On the other hand, it is important to identify at which volume scale—since biogas is a distributed resource accessible only in relatively little individual pools compared to natural gas—downstream technology may work or not work with biogas. The first topic was addressed in the portfolio. The latter was not. This synergy—and to a certain extent conflict—was most evident in Lactic Acid Producing Methanotrophic Bacteria for Fermentation of Bio-Methane as a Biological Upgrading Technology. This project has preliminarily shown that CO₂ dilution may be a significant inhibitory factor in methane conversion, as the solubility of methane in the liquid phase is further reduced by the presence of CO₂. If total carbon utilization is not possible, we see opportunities to focus on reducing the cost of biogas pretreatment. This reduction would also increase the opportunity for pipeline injection of biogenic methane and, ultimately, further expand the synergy between methane utilization and biogas production. Although this topic was not a particular focus of the WTE Technology Area, we believe it may be an interesting area to explore for future activities. The project Enhanced Anaerobic Digestion addressed higher-quality biogas production and is in line with this intent, but we had no consensus on its merits and the actual state of development. Ultimately, some of the projects addressing biogas conversion may find an easier path to commercialization using natural gas and getting credit for renewable methane injected in the pipeline.

Focus

As an emerging area in the portfolio, there was still a perceived lack of a strong topical focus, and many of the projects could easily have found a home in oth-

er programmatic areas within BETO, although none was clearly or obviously misplaced in the WTE Area. Nonetheless, the main thread was wet-low or no-value feedstock use, with a strong sub-theme of biogas and biogas-related technologies. We believe this should remain the primary focus of the area. An emphasis on reducing the capital intensity of AD should also be part of this programmatic area. As mentioned, these topics are in part addressed by Enhanced Anaerobic Digestion. Without entering into details that are more appropriately discussed in the detailed project review, this project also shows some lack of clear focus, as it commingles two research areas with limited interaction. Future larger consideration of the organic/cellulosic component of the MSW could also fit this thrust, especially if addressing the use of unsorted MSW, which would otherwise go into landfills. Lastly, while it was well-received, the single project dealing with the use of wet lignin from a biorefinery was also apparently not as connected to the main theme as all the other projects followed. Nonetheless, as lignin valorization remains a key challenge for the development of biorefineries, we believe that acknowledging wet lignin as a waste may enable new innovative solutions, like the one presented in Biomass Electrochemical Reactor for Upgrading Biorefinery Waste to Industrial Chemicals and Hydrogen.

Commercialization

This report already identifies some critical gaps to overcome before commercialization. As mentioned earlier, system modeling and inventory efforts need to address the local nature of WTE feedstock availability. Lack of granularity may limit the audience for this effort. In the case of WTE system modeling, our recommendation is to take a clear bottom-up approach and focus first on selected regional areas—for instance, a large urban area—and then expand the modeling effort.

The fact that this programmatic area is not directly addressing MSW may or may not be a gap, depending on how the WTE Technology Area is defined. The Review

Panel, while not having a clear consensus on this, leans towards inclusion, and we recommend that a clear determination is made as the WTE Technology Area continues and the portfolio may expand.

We noticed some common gaps, some of which may have impacted the ranking of projects. We understand that a detailed analysis of the regulatory barriers may be too early and unduly cumbersome for most projects at this stage of definitions. However, given the importance of regulatory issues in the WTE Area, we found the complete absence of considering regulatory issues surprising. We believe this is particularly relevant for technologies, such as HTL, aiming to co-locate with existing WWTPs. At a programmatic level, this becomes critical as policymakers may ultimately look at the direction set by these programs to identify policies.

There were larger gaps in the lack of consistent presentation between projects. In particular, we lament the lack of consistency in how TEA data and assumptions were presented. The lack of consistent communication appeared in some projects where it was not immediately clear what the stage-gate goals were and if those goals had been reached or missed. While, in part, this is the artifact of necessarily limited presentation times and of the need to preserve the confidentiality of critical intellectual property (for a project led by the private sector), we do nonetheless feel that this area could be improved.

The lack of consistency in the TEA was also quite evident. Some projects did not address it at all. Once more, we do understand that a very early stage of technology development with too much detail on the TEA can become an undue burden. We believe that TEA can help if used in the context of a scenario analysis, such as “under which conditions will this technology reach my benchmark?” The benchmark itself can be based on future expectations rather than present. For instance, in biogas-related technologies, today’s natural gas prices

may be an impossible benchmark, but higher prices in the future are plausible. These would be a good reference that is also aligned with the long development and commercialization time of these technologies. Ultimately, we believe that even when a detailed TEA is not in the scope of the project, appropriate TEA elements should be included.

Finally, with some exceptions, we noticed a disconnect with the possible private or—in the case of wastewater treatment—local government stakeholders. When more detailed TEAs were presented, some key financial benchmarks were not in line with industry standards, and the assumptions on end-product value and quality were wanting. Moving forward, TEA assumptions and results will benefit from better vetting and earlier challenge of assumptions. We believe that addressing the lack of consistency in the TEA will also help to address a gap we often noted between the end of the project and the follow-up towards commercialization.

The last apparent gap is the use of HTL as a benchmark for a variety of WTE opportunities and characterizations. While we do not argue against its potential, HTL is not yet a well-known and established technology. Most importantly, it has yet to be implemented on a commercial scale. Because of that, it may not be a meaningful benchmark for the general practitioner in the industry. This critical audience, on the other hand, is very well-versed in AD, and we consider AD a better benchmark. Given its potential, we do not argue for scrapping HTL as a point of reference, but for the foreseeable future, we advocate also using AD as HTL establishes itself as a viable commercial solution.

The analysis of these commercialization gaps should not detract from the programmatic value of the WTE portfolio. This value will be enhanced by addressing the gaps, none of which significantly impact the high scientific value and rigor of the projects presented.

Recommendations

The recommendations for the further development of this programmatic area reiterate suggestions in part already expressed elsewhere:

- Continue and extend the focus on the fundamentals of AD, from microbiology to enhanced control and monitoring.
- Develop methods and standards that the industry may be able to adopt. Use realistic benchmarks that relate to the industry and can be used by practitioners in the area.
- Continue the modeling and inventory efforts, but recalibrate the modeling effort starting at the local level rather than at the national level. Those are of immense value to the industry, and no place is better suited than the national laboratories to lead this work.
- Include a more direct consideration of existing regulatory and operational constraints in the evaluation of projects/technologies and their route to adoption. While no project should be rejected purely based on regulatory constraints, it should be clear that the higher the regulatory hurdle, the higher the benefits need to be to justify regulatory changes and the longer the adoption time. These issues should also be reflected in the TEA.
- Projects that do not work well with biogas—because of scale or other considerations—may work well with methane, and we believe there should be a stronger focus on biogas upgrading technology. However, projects that may not function well with raw or only partially conditioned biogas with sufficient scale of biogas availability at a single source do not belong in the WTE Technology Area. This observation is not to discourage BETO to initiate these projects, but to define clear benchmarks for understanding when further work on the technology may be better carried out in another programmatic area, regardless of the project’s technical merits.
- Lastly, while this is not directly related to the programmatic area (but is consistent with the observations present elsewhere in the report), improve the presentation format during the Peer Review.

WTE PROGRAMMATIC RESPONSE

Introduction/Overview

BETO thanks the Review Panel and the PIs for their time and efforts to improve our portfolio. BETO appreciates the reviewers’ concerns about presentation format and consistency and will work to improve these areas at future reviews.

Because WTE is a relatively new area in the BETO portfolio, we realize that many areas are still emerging, and in some cases scope may not have been clear to the Review Panel. One such area was the role of MSW within the WTE portfolio, which will be clarified going

forward to avoid confusion. While the focus of the WTE resource assessment has primarily been on high-moisture feedstocks (e.g., sludge and manure), cost-benefit analyses and infrastructure assessments will be conducted in Fiscal Year (FY) 2018 to consider all organics included in MSW. BETO was also encouraged to hear the appreciation for WTE as a solution to waste lignin. Lignin utilization continues to be an increasingly important topic of BETO’s portfolio in FY 2018, addressed primarily in the Biochemical Conversion portion of the Conversion R&D Program.

We agree that biogas from WTE has synergies with methane from other non-biomass sources. To this end, BETO is engaged with DOE’s Office of Fossil Energy

to seek synergistic activities in this area. BETO focuses specifically on innovative technologies that may upgrade biogas or biogas precursors to liquid transportation fuels and bioproducts, utilizing technologies that are efficient at the scale of WTE feedstocks.

We agree that when pursuing innovation in WTE conversion, concomitant analysis in mobilizing distributed waste feedstocks is critical. This analysis may include understanding logistics/handling and evaluating scalable, localized technologies. The comments from the Review Panel are noted. Additionally, we note the Review Panel's comments on more consistent TEA.

The following sections address the three top recommendations from the Review Panel:

Recommendation 1: Extend the Focus on the Fundamentals of AD

We agree with the Review Panel that we should extend the focus on the fundamentals of AD (microbiology to enhanced control and monitoring). BETO has specifically identified a systems biology understanding of AD as an area of interest in the FY 2018 WTE laboratory call. Interests include an improved understanding of bacterial and archaeal community dynamics within digesters, as well as toolkit development, including omics.

Recommendation 2: Develop Methods and Standards for Industry

We agree with the Review Panel on the importance of developing methods and standards for industry and of using realistic conversion benchmarks (as opposed to just HTL). Future analysis efforts, including those in FY 2018, will include more industrially accepted baselines for evaluating

resource potential, e.g., AD as a baseline conversion for sludge and manure, and compost for food waste.

Recommendation 3: Recalibrate Modeling Efforts to the Local Level rather than the National Level

We agree to recalibrate the modeling effort starting at the local level rather than at the national level. BETO hosted a workshop in California in June 2017 to learn more about WTE resources and policy frameworks at the state level, including policies surrounding emissions reductions and carbon intensity of fuel use, regulations surrounding pipeline injection, and site permitting. While BETO does not make policy, it can inform policymakers and pursue new technologies that address the constraints that industry has in meeting current policy and regulations.

To follow up, we are working with the Waste-to-Energy: Feedstock Evaluation and Biofuels Production Potential project on ramping up resource assessment activities to establish regional and state supply curves that utilize county-level (and point-source) resource data available for sludge, manure, biogas, food waste, and fats/oils/greases. The WTE Simulation Model project is also exploring WTE modeling on a state and local level. A California-specific model will be developed by the end of FY 2017. Future efforts will look at other regions and leverage synergies where possible, while also addressing unique localized challenges and opportunities. Improving these models will enable BETO's WTE Technology Area to serve as a streamlining tool to enable synergy across different regions and states of the United States, while respecting the specific key challenges and opportunities any one state must address.

WTE SIMULATION MODEL

(WBS #: 2.1.0.104)

Project Description

The goal of this project is to build and exercise a system dynamics model of the U.S. WTE industry to gain insights into the industry’s development. Project outcomes include a completed and vetted system dynamics model of the WTE system in the United States and analyses that directly address specific BETO questions regarding the development of the WTE industry. This project is relevant because it provides actionable analysis of the nascent WTE industry (e.g., identifying bottlenecks, synergies, impacts of R&D decisions, policy implications, and areas of leverage). The WTE System Simulation Model uses a system dynamics modeling framework. The model is built from vetted and/or published resource, market, and techno-economic data. It uses a flexible, modular, and transparent architecture. Project

Recipient:	National Renewable Energy Laboratory
Principal Investigator:	Danny Inman
Project Dates:	5/1/2015–9/30/2018
Project Category:	Ongoing
Project Type:	Annual Operating Plan
DOE Funding FY 2014:	\$0
DOE Funding FY 2015:	\$50,000
DOE Funding FY 2016:	\$400,000
DOE Funding FY 2017:	\$390,000

accomplishments include the following: conducted three interactive model exploration sessions with BETO, completed initial analysis of the energy potential from landfills and concentrated animal feeding operations, updated data sources, and developed a model of the Renewable Identification Number market. Future work will be focused on major model expansion—linking to the Biomass Scenario Model, high-impact analysis of the D3 Renewable Identification Number market, and a large sensitivity study.

Weighted Project Score: 7.1

Weighting: For ongoing projects, there is equal weighting across all four evaluation criteria: Approach, Relevance, Accomplishments and Progress, and Future Work.

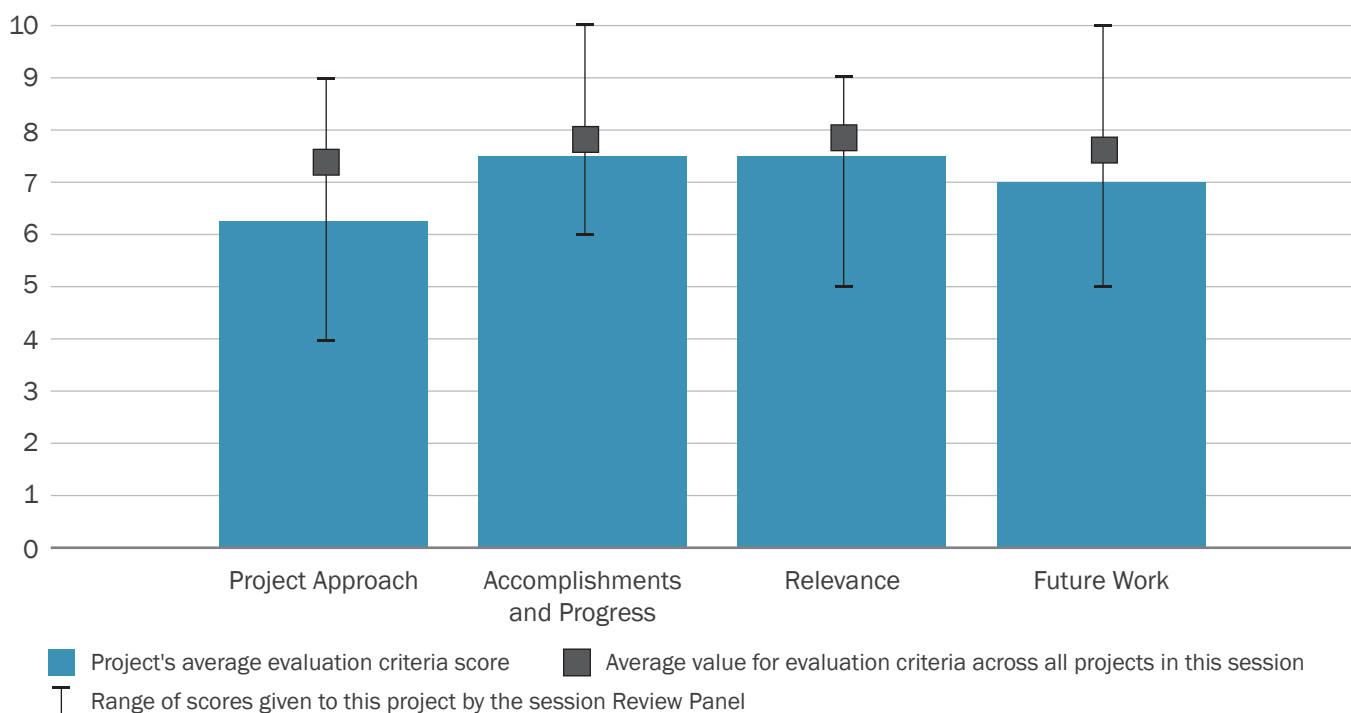

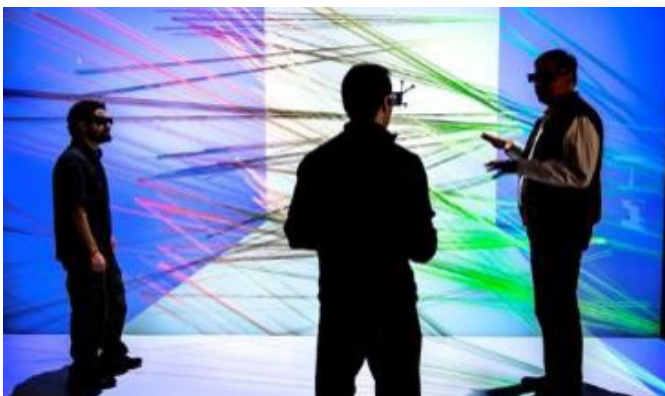

Overall Impressions

- This is a valuable modeling exercise with far-reaching benefits to many aspects of the energy sector.

As with any modeling-driven or based project, one needs to understand how the tool can be used and how it breaks.

- An adaptable, regionalized system dynamics model of WTE systems would be a valuable tool to identify and prioritize investment opportunities.
- The main comment was laid out immediately. We believe this effort, while based on a sound scientific approach and certainly addressing a need of the industry, is fundamentally undermined by the lack of granularity. The integration with the Bioenergy Knowledge Discovery Framework is positive, but ultimately, the lack of granularity makes it of limit-

ed use to some of the stakeholders on which the developers may most depend to collect industry data. Those are the practitioners in the field whose work is intrinsically regional. We see utility for policy-makers at the national level. Alas, since implementation is often local, the model as it is today may provide scant support to regional decision makers. Overall, the aim of the project is good, but the scope needs refining.

- This project, which is focused on development and utilization of a system dynamics model for the WTE industry, provides an important and useful tool for BETO to explore how the industry may respond to various forces, such as feedstock availability, market behavior, and policy effects. As it is refined and expanded, it will also be useful for other stakeholders in WTE technology, and it is a unique and valuable contribution. There is concern with how universal the model structure is considering potential different responses to the same stimulus by different regional sections of the United States. A recommendation is to focus and verify the model based on localized regions rather than on a national level.

PI Response to Reviewer Comments

- No official response was provided at the time of report publication.

WASTE-TO-ENERGY: FEEDSTOCK EVALUATION AND BIOFUELS PRODUCTION POTENTIAL

(WBS#: 2.2.1.108)

Project Description

The goal of this project is to provide foundational data, strategic analyses, and resource assessment modeling critical to the economic and environmental viability of the emerging WTE industry. It began in the last quarter of FY 2015 to support BETO’s objectives in accelerating development of WTE technologies. These technologies offer alternative and sustainable solutions to waste disposal—a growing concern across the nation as population grows—and could present a niche opportunity for the bioeconomy of the future. Our accomplishments to date include the following: (1) An estimate of the wet WTE resource potential for wastewater sludge, animal manure, food waste, and fats, oils, and greases; and (2) an estimate of the biofuels potential from wet WTE

Recipient:	National Renewable Energy Laboratory
Principal Investigator:	Anelia Milbrandt
Project Dates:	5/1/2015–9/30/2018
Project Category:	Ongoing
Project Type:	Annual Operating Plan
DOE Funding FY 2014:	\$0
DOE Funding FY 2015:	\$40,000
DOE Funding FY 2016:	\$640,499
DOE Funding FY 2017:	\$690,000

sources via HTL conversion process as a “baseline.” Our analysis indicates that wet WTE resources have the potential to produce about 9 billion gasoline gallon equivalent per year, about 6.4% of 2015 U.S. gasoline consumption. About half of this potential is generated from animal manure. If an HTL conversion process is utilized, these resources could yield about 6 billion diesel gallon equivalent per year, about 15% of 2015 U.S. on-highway diesel fuel consumption. This analysis provides the first estimate of wet WTE resource potential below the national level (at point location for most

Weighted Project Score: 8.5

Weighting: For ongoing projects, there is equal weighting across all four evaluation criteria: Approach, Relevance, Accomplishments and Progress, and Future Work.

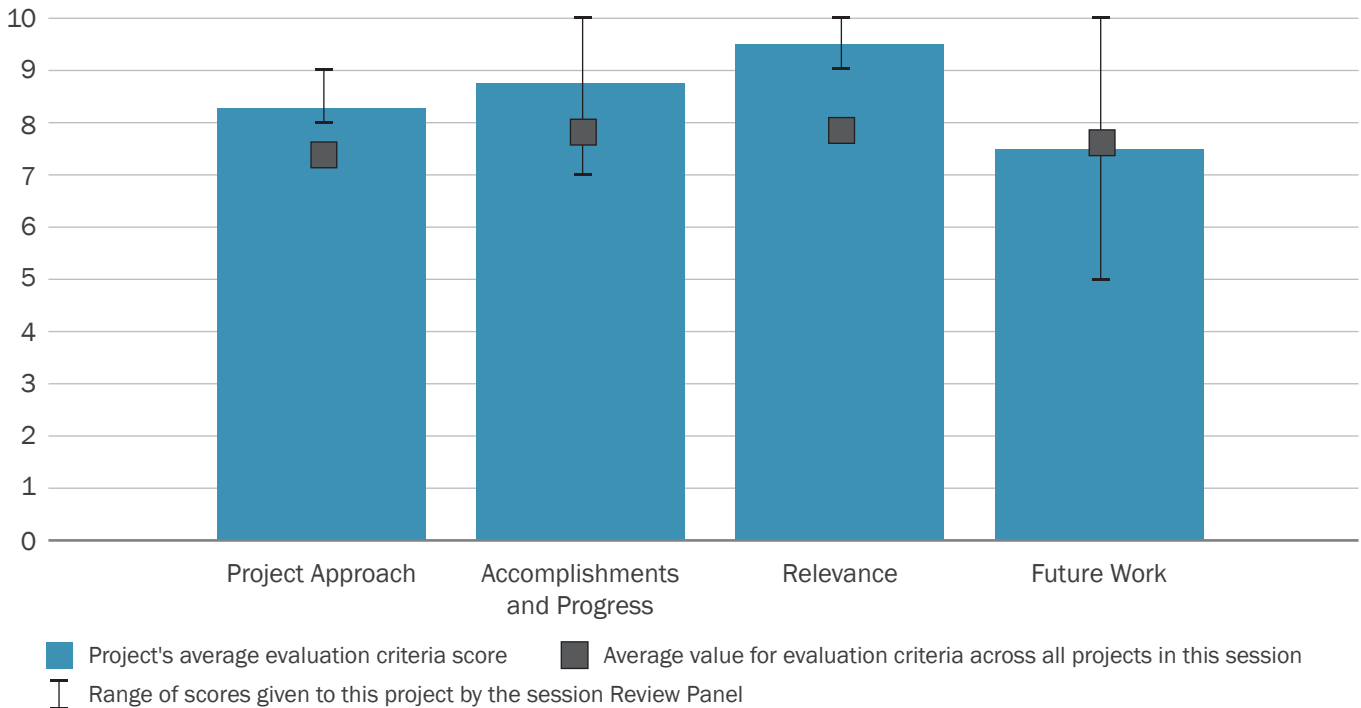



resources). Project challenges included data availability and quality, which were mitigated by ongoing industry input.

Overall Impressions

- This needs feedstock costs for TEA relevance (currently unavailable). It would be good to have a clearer methodology for getting that information.

It is not clear from the presentation deck if the HTL is a good metric for benchmarking; it would be good to clarify, including why it is a good/not perfect choice. It might be more relevant to use wastewater industry metrics as well?

- This project will provide critical data to a growing WTE industry that will facilitate prioritization of strategic investments for market development and technological innovation.
- One question for the researcher is whether the inclusion of poultry manure (litter) should be considered. While, in volume, it is relatively small compared to other animal wastes, it has a very large environmental impact, as seen in well-publicized cases of ground and surface water pollution. Lastly, from a methodology prospective, I believe that the environmental value (or environmental service value) of using waste for energy should be considered. Can we improve the disposal or reduce the disposal of organic chemicals in the environment? Can we provide a platform to recycle them? While I realize that a complete analysis of the “environmental service

value” of WTE solutions may be beyond this project, I believe that this project in its last phases can lay the groundwork for this as a future follow-up project.

- This project, which is focused on assessing the size and distribution of wet waste resources and potential energy value of these resources, constitutes a tremendous effort and is of very significant value to the WTE and biofuels/bioproductions industry. The authors are almost too modest in conveying the difficulty and amount of work that has gone in to this effort and the results achieved. The project is clearly of relevance to BETO and is critical to the focus of utilizing the previously underappreciated potential of wet waste materials as a feedstock for useful fuels and products.

PI Response to Reviewer Comments

- We thank the reviewers for their valuable input and support.

We agree with the reviewers that feedstock cost is very important for TEA. The results of our feedstock cost analysis will be provided not only to the TEA team at Pacific Northwest National Laboratory, but also to the WTE system dynamics modeling team at the National Renewable Energy Laboratory and any other entity requiring that information. Given the time constraints during the Peer Review, we were unable to discuss the details of this task, which is ongoing. We are working closely with industry to gather cost information and will seek industry’s feedback on final results.

There are several reasons we selected HTL as our baseline conversion pathway, as follows:

- Experimental results to date strongly support HTL as a robust conversion technology potentially well-suited for the wet wastes addressed in this study. This was reinforced by Pacific Northwest National Laboratory’s experience with sludge feedstock, as well as specific examples

found in the literature reporting successful HTL conversion of each of our target feedstocks to biocrude, a reasonable intermediate for upgrading to transportation fuels.

- This body of experimental results enabled the development and use of a correlation-based HTL conversion model to reasonably and consistently estimate the biocrude production potential for each of our feedstocks. It should also serve as a reasonable model for evaluating feedstock blends.
- Given BETO's ongoing investment in development of HTL, we are now positioned to use the results of this study to help guide the HTL experimental design toward focusing on the most

promising feedstocks in terms of their availability and biochemical characteristics.

- Finally, though we used HTL for our initial baseline, we plan to directly compare HTL with AD as part of our future work.

We agree with the reviewer that poultry manure is an important environmental concern. However, it is generally a dry feedstock. The exception is manure from laying-hen operations, which contains more liquid than broiler waste and could be considered as a wet feedstock in the future.

We certainly agree with the reviewers that the environmental value of using waste for energy should be considered. Our plan is to address the environmental value of WTE technologies in FY 2018.

HYDROTHERMAL PROCESSING OF BIOMASS

(WBS#: 2.2.2.301)

Project Description

This project is working to advance the state of HTL technology, improve overall process performance and economics, and determine the value and best pathway to market for the HTL output products. The HTL technology at PNNL has unique and compelling attributes for producing biocrude from woody, agricultural, and waste feedstocks. This effort will advance the technical readiness/modality of HTL through leveraging existing capabilities, programs, key relationships, and the recent HTL developments under national consortiums (National Advanced Biofuels Consortium and National Alliance for Advanced Biofuels and Bioproducts) and Work for Other agreements. We will focus our R&D efforts on the highest-priority challenges identified in internal and independent TEAs and design evaluations.

Recipient:	Pacific Northwest National Laboratory
Principal Investigator:	Rich Hallen
Project Dates:	10/1/2015–9/30/2018
Project Category:	Ongoing
Project Type:	Annual Operating Plan
DOE Funding FY 2014:	\$450,001
DOE Funding FY 2015:	\$1,350,000
DOE Funding FY 2016:	\$2,200,000
DOE Funding FY 2017:	\$2,050,000

Overall Impressions

- This is a very interesting advancement in the technology with promising results. The project is adequately progressing with a clear path for commercialization in many areas. I would like to understand what a broader rollout of the HTL (past the optimal seven sites) will require for commercial viability on yield/efficacy from other feedstocks, from a performance perspective, and/or with capital expenditure in the project goals. What would the yield

Weighted Project Score: 7.3

Weighting: For ongoing projects, there is equal weighting across all four evaluation criteria: Approach, Relevance, Accomplishments and Progress, and Future Work.

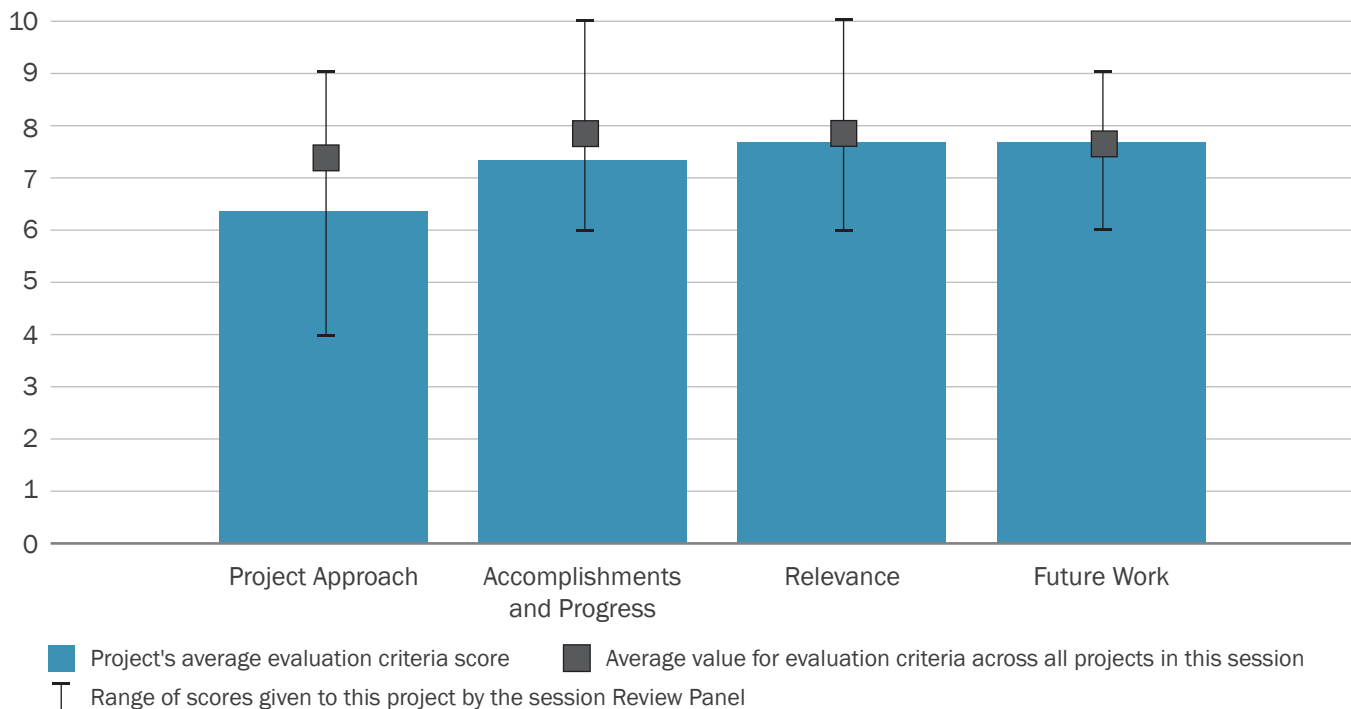

improvements and cost reductions that the project team identified that are not included in current TEA estimate do to the rollout potential?

The Review Panel stated that investors will require a minimum 15% return on investment. BETO could suggest the standard financial assumptions to be used by all projects in given areas to keep them on the same scale.

The suggestion was made by the Review Panel to clarify the blendstock work package for the future work.

- HTL has tremendous potential to valorize waste biomass.
- Overall, I find this project has considerable merit and is of great relevance. Unfortunately, I think various methodological approaches detract from it. Nonetheless, the scale at which this was done is considerable and of value. The piloting effort is a considerable accomplishment. The authors need to focus on the next part of the project in strengthening the economic case and studying in detail techno-economic challenges associated with scaling and transitioning this technology. The work to date has demonstrated more than adequate technical viability. The case for economic viability at scale is not clear yet. I hope this can be addressed in the remainder of the project.

PI Response to Reviewer Comments

- We are grateful to the Review Panel for their insights and highlighting techno-economic considerations for commercial application of the process. Many of the questions raised by the panel are of active interest to this project. We are currently ad-

ressing process economics from resource availability to the market value of finished products in the design case due to be completed this year. A preliminary TEA/life-cycle analysis has been published. With respect to process scalability, we have obtained a third-party evaluation of the HTL process in previous years by the Harris Group. We have used this evaluation to guide our bench-scale process development and the design of the engineering scale system (modular hydrothermal liquefaction system). We plan to use data from the modular hydrothermal liquefaction system to assess scalability and provide a rigorous basis for pilot-scale system design.

The comments on refinery integration confirm our current approach with upgrading and characterization of products, but also suggest exploring additional integration strategies with refining partners. During HTL process development within several national consortia (National Advanced Biofuels Consortium, National Alliance for Advanced Biofuels and Bioproducts), Pacific Northwest National Laboratory interacted with refining companies, leading to the current strategy of producing a fuel blendstock for integration. The HTL team recently met with operators of a small refinery to discuss integrating sludge-derived HTL biocrude and received feedback similar to that expressed by the Review Panel. Continuing engagement of the downstream stakeholders will be critical to commercial success. We strive to be grounded, practical, collaborative, and conservative in our approach so that we are testing available and sufficiently abundant resources and producing products that have market, as opposed to theoretical, value. The Peer Review Panel has helped focus our efforts toward that goal.

ENHANCED ANAEROBIC DIGESTION

(WBS#: 2.2.4.100)

Project Description

Argonne has been developing a low-cost WTE process to produce renewable methane. The project goals are to transform negative-value or low-value waste streams into high-energy-density, fungible renewable methane through targeted research, development, and demonstration. Our ultimate goal is to reduce biogas production and upgrading costs by increasing biogas quality, decreasing the need for gas cleanup, and increasing the reaction rate and yield. We started with sludge generated during wastewater treatment as carbon and energy sources and produced a biogas with ~90% methane content—rather than 55%–70% methane (volume/volume) produced in conventional digesters—using Argonne’s novel, low-cost treatment additive process at bench-

Recipient:	Argonne National Laboratory
Principal Investigator:	Meltem Urgun-Demirtas
Project Dates:	10/1/2013–9/30/2017
Project Category:	Ongoing
Project Type:	Annual Operating Plan
DOE Funding FY 2014:	\$500,000
DOE Funding FY 2015:	\$750,000
DOE Funding FY 2016:	\$750,000
DOE Funding FY 2017:	\$550,000

scale digesters (0.5 liters). We evaluated pathways to piloting and scale-up of the AD process to 14-liter digesters in FY 2016 based on performance results obtained in FY 2015. We considered a variety of factors, including organic and biochar loading rate and retention time that affects the rate of digestion and biogas production in the full-scale digesters, to enhance the gas production and maximize methane content in the biogas (>90% methane). The chemical composition of digestate, left over after AD of waste, was analyzed to determine the

Weighted Project Score: 6.1

Weighting: For ongoing projects, there is equal weighting across all four evaluation criteria: Approach, Relevance, Accomplishments and Progress, and Future Work.

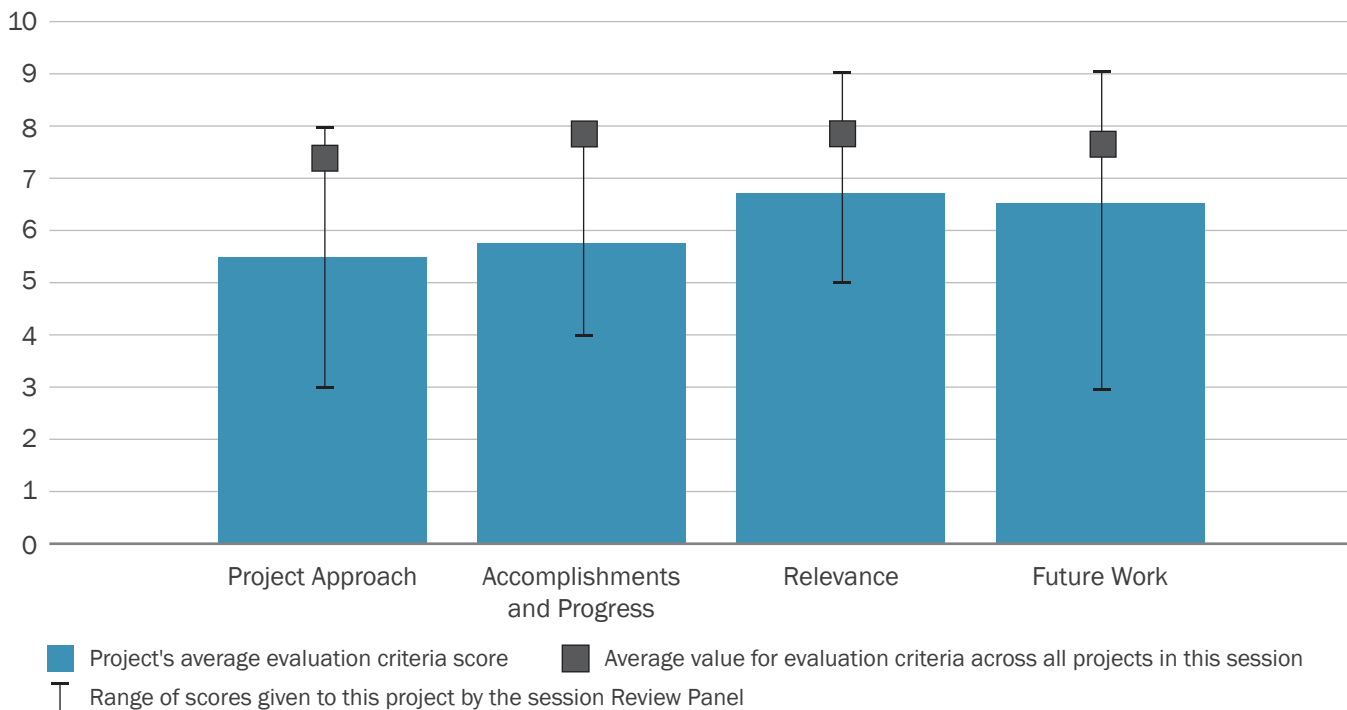

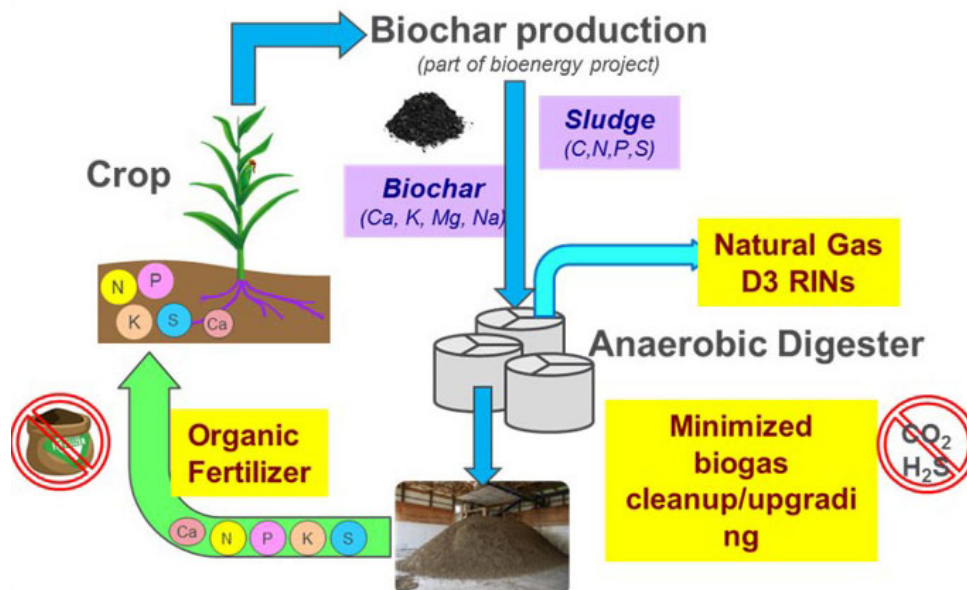

fertilizer value provided by biochar addition that can be used for growth of energy crops. We will conduct field demonstration of the additive technology in a full-scale digester in FY 2017.

Overall Impressions

- It would be nice to see the results presented in context of the necessary performance/TEA goals so that it is easier to understand the project’s progress towards commercial relevance. What are the implications of the no-go on the hydrocarbon production piece?

The project has worked on city sludge, but it was stated greater technology relevance is for farmers, where higher total solids up to 10% is relevant.

- Increasing the methane content of AD could increase the value of biogas.
- Overall, the topic and aims of this project are relevant. While there is a questionable link between the two tasks—besides the feedstock—and little technical overlap, each topic has merit. The decision of interrupting one of the tasks, as the results did not support its continuation, was correct and demonstrated an appropriate approach to the evaluation of a project outcome.

- Unfortunately, serious doubts remain pertaining to methodology. The presentation was somewhat confusing, and the data were not completely clear. Most importantly, the scale at which this project was carried out is still bench and not pilot as claimed.

Lastly, the TEA is wanting, and the assumptions about economics, availability, and suitability of biochar use at industrial scale are weak.

- Both tasks in this project, generation of higher methane content and purity in biogas and liquid fuels from sludge via biochemical conversion, are worthy efforts. Achievement of the target goal of greater than 90% methane in biogas with low H₂S at bench and pilot scales is significant, though it would be more helpful if the mechanism (involving addition of biochar to the sludge feed) and effects of the many variables explored in this study were better explained. Recognition of the lack of desired results in the liquid fuels production task and subsequent ending of this task represented an honest assessment of results that did not turn out as expected (through no fault of the investigating team) and was a commendable savings of resources.

PI Response to Reviewer Comments

- The sludge stream has limited carbon and pretreatment constraints and an additional waste stream didn't increase the C/N ratio to 100, which is an optimum condition for producing lipids. It also should be mentioned that a consortium of oleaginous microorganisms also requires the addition of glucose and yeast. The addition of these carbon sources is outside of BETO's goal to develop cost-effective new technologies from lignocellulosic feedstocks.

The field-scale testing will help us to understand the impact of solid content on the process performance. It should be noted that solid content in the big farm effluents drops to 2%–5% due to washing and cleaning activities in the farms, which generate voluminous amounts of wastewater that need to be treated.

As indicated in slides 4, 6, 7, and 8 of the presentation and PI talk, the two tasks were distinct but parallel, and they started at different times. BETO combined these tasks for project management convenience since the same feedstocks and AD process were used for both tasks.

There is no definition for the size of bench-, pilot-, and field-scale applications in the literature since this definition depends on tested technology and reproducibility, scalability, and transferability of the bench-scale results. AD technology is very well-

known and can be easily scaled up. We used 14-liter digesters since we can only accommodate 2 weeks of sludge supply because of transportation, storage, and disposal issues during the 1-year continuous digester operations. Sludge testing is considered to be Biosafety Level 2 per the Occupational Safety and Health Administration; therefore, we had to follow stringent laboratory protocols and guidelines.

Biochar production is an emerging industry in the United States, and therefore, all TEAs will have shortcomings. We used biochar, which is a byproduct of pyrolysis of lignocellulosic materials, to help BETO to develop a biorefinery concept where the byproducts can be used in the subsequent process(es) to develop sustainable and cost-effective technologies. Nevertheless, we are also looking for other alternatives that can replace the biochar, such as bottom ash generated from coal-fired power plants and ash generated from biopower plants.

The CO₂ removal mechanism is based on natural weathering process and adsorption. These were mentioned in slides 4 and 5 and during the PI presentation. The application number of the patent pending process was also cited for more information. The presentation also included the tested conditions, such as operating temperature (mesophilic versus thermophilic), organic loading rate, and biochar loading rate, as well as biochar type and impact.

LACTIC ACID-PRODUCING METHANOTROPHIC BACTERIA FOR FERMENTATION OF BIO-METHANE AS A BIOLOGICAL UPGRADING TECHNOLOGY

(WBS#: 2.3.1.203)

Project Description

In 2013, NatureWorks kicked off joint development with Calysta for biocatalyst/fermentative conversion of methane to lactic acid. In May 2015, NatureWorks began working with DOE-BETO under EE-0006876 to synergize this effort with biogas in support of a business case for cost-competitive biofuels. The project focuses on activities within TRL 3–4, with a techno-economic model at commercial scale defining the sensitivity of lactic acid cost of goods produced for target less than \$0.30/pound of lactic acid.

Recipient:	NatureWorks LLC
Principal Investigator:	Ken Williams
Project Dates:	2/1/2015–1/31/2018
Project Category:	Ongoing
Project Type:	FY 2014—Biological and Chemical Upgrading: DE-FOA-0001085
Total DOE Funding:	\$2,500,000

This project supports BETO’s mission to achieve less than \$3/gasoline gallon equivalent biofuel by creating commercially relevant co-products from waste streams at integrated biorefineries. This project leverages NatureWorks’ biopolymer production and markets for lactic acid as a platform chemical. Challenges include the following: (1) low methane solubility in aqueous fermentation media, (2) the need to co-feed multiple gases at high mass transfer rates/allow efficient removal of CO₂, and (3) heat removal from metabolism of high-energy methane substrate. Accomplishments include the following: chromosomally integrated lactate dehydroge-

Weighted Project Score: 7.3

Weighting: For ongoing projects, there is equal weighting across all four evaluation criteria: Approach, Relevance, Accomplishments and Progress, and Future Work.

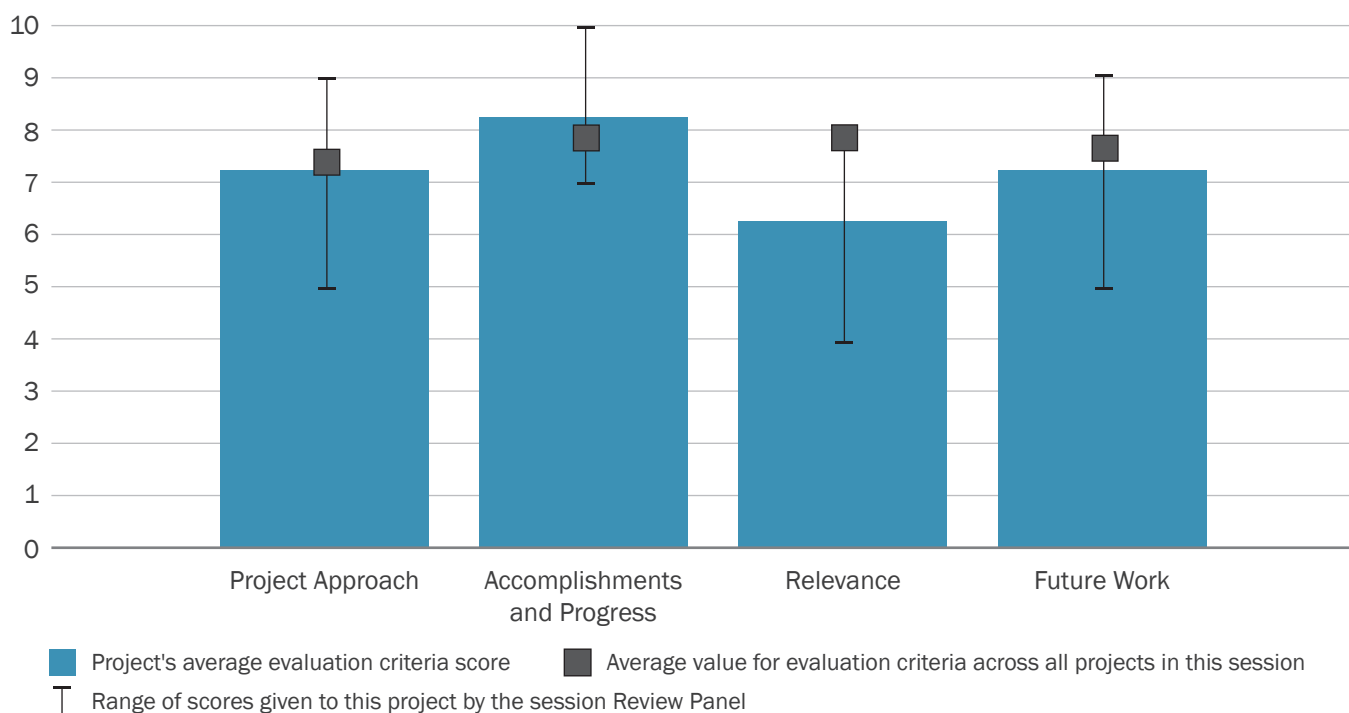



nase strains; validated promoter system; filed successful patent application on engineered methanotroph strain; achieved a 5 order of magnitude titer improvement in under 3 years at 2-liter scale; built gas-fed fermentation laboratory (approximately \$1 million) and world-class fermentation/biology team at NatureWorks towards stage-gate goal of \$0.90/pound cost of goods produced target; developed opportunity for waste biogas and supply chain from WWTPs.

Overall Impressions

- The stage-gate milestone to go to pilot scale and the anticipated improvements there are a little unclear, as mass transfer historically becomes more difficult as scale is increased. It would be good to clarify the parameters that are known to give this upside, as it may be a good way to avoid stalling the project.
- I would like to see the next steps on strain development at Calysta, as it looks like it may need new tools or paths to realize success with inhibitor sensitivity (lactate, H₂S, CO₂, et al.).
- A core strength of the project is the potential to valorize biogas through the economical production of industrially relevant chemicals.
- I struggled with this project. I think the effort to use methane as a source of carbon for industrial ferment-

tation and to replace carbohydrates has considerable merits.

My key struggle is that NatureWorks has used BETO funds to supplement a largely self-funded project with the BETO funds going towards biogas rather than methane. After the review, I believe the biogas effort is questionable for fundamental reasons that transcend the quality of the results. Here I repeat points made before.

- I have two main observations:
 - The PI clearly stated that production of lactic acid and polylactic acid adjacent to a single biogas facility is not realistic given the biogas demand, which, for a commercial unit, would require “the biogas production of the whole state of Minnesota,” in his words.
 - Results show that CO₂/CH₄ blends are not as suitable of a feedstock as pure methane. This is most likely because of reduced solubility of CH₄ or possibly other inhibitory effects. This, in addition to the unavoidably poorer operating cost of biogas (where around 40% of the gas volume pumped is not available under each circumstance), makes biogas economically less attractive.

Given these considerations, it appears clear to me that if NatureWorks wants to use biogas for carbon offset and life-cycle analysis reasons, they are better off buying renewable gas credits from biogas producers who do pipeline injection. Scalability and CO₂ issue would be addressed by this approach, and the technical work should then fully concentrate on high-quality, pipeline-grade methane as the most likely feedstock.

I also find that the capital expenditure associated with the collection of raw biogas from a municipal WTE plant is not quite entirely justifiable. Biogas is mostly CH₄ and CO₂, with smaller amounts of H₂S and NH₃; “fresh” is also likely to be saturated. Creating “fake” biogas in the laboratory is pretty simple. It is true that

there are smaller trace amounts of other compounds, but their presence is often very dependent upon the particular feedstock. If those are of concern, focusing on raw biogas from a single source is probably not helpful to scale the process. Removing those—which is done as a matter of course to make the gas pipeline grade—is more useful.

Ultimately, I can't avoid considering this an interesting technical exercise but of scant impact.

- This project is one of three in this session that focuses on genetic engineering of methanotrophs to produce valuable co-products (lactic acid in this case) from biogas. Lactic acid is a valuable product, and successful production at target cost, if achieved, will be significant and worth the effort. Given conceptual and approach similarities, it would make sense to encourage communication and interaction between the National Renewable Energy Laboratory and NatureWorks to make the best use of resources and avoid duplication of efforts where possible. Given the results of notably higher lactic acid production from pure methane relative to biogas and current prices for natural gas, it is unclear whether NatureWorks (as a for-profit company) will utilize any developments made in this project with a biogas feed.

PI Response to Reviewer Comments

- We sincerely appreciate the time and effort the reviewers spent critically examining projects in DOE-BETO's portfolio. It is difficult to fully address the comments and concerns raised in the space available, but here are a few points:

The stage-gate milestone to pilot scale is NatureWorks' internal milestone and falls outside the

scope of DOE-BETO's project. The stage-gate milestone for the DOE project entails hitting specific targets for titer, productivity, and yield at 2-L fermenter scale. In the presentation, we outlined next steps for the projects focused on improving product tolerance.

The feasibility of providing adequate biogas supply for commercial plant is largely dependent on chemical oxygen demand of influent feeding wastewater treatment facility and size of facility. For example, technical report NREL/TP-5100-60223³³ describes a lignocellulosic sugar-to-hydrocarbon plant that produces enough biogas to support a ~120 million pounds/year lactic acid plant. The PI's point during the Peer Review presentation specifically detailed how much biogas would be needed for our internal design case (460 million pounds/year of lactic acid). The Blue Lake facility where we sourced biogas is producing 26,000 standard cubic feet/hour or ~0.6 million standard cubic feet/day. A 200 million pounds/year lactic acid plant would need 6 million standard cubic feet/day. However, Blue Lake is only the third largest of seven wastewater plants in the Twin Cities area.³⁴

Essentially, Blue Lake produces one-tenth of the biogas a commercial-scale lactic plant would need annually. NatureWorks is fully aware of current limitations and recognizes the challenges associated with first mover disruptive technology deployment, which are consistent with similar value-chain constraints in launching Ingeo Polylactides over a decade ago and are analogous to challenges facing lignocellulosic biofuels deployment today. We applaud DOE-BETO's leadership in this area and will continue our mission towards feedstock diversifica-

³³ R. Davis, L. Tao, E. C. D. Tan, M. J. Bidy, G.T. Beckham, C. Scarlata, J. Jacobs, et al., *Process Design and Economics for the Conversion of Lignocellulosic Biomass to Hydrocarbons: Dilute-Acid and Enzymatic Deconstruction of Biomass to Sugars and Biological Conversion of Sugars to Hydrocarbons* (Golden, CO: National Renewable Energy Laboratory, October 2013), NREL/TP-5100-60223, <https://www.nrel.gov/docs/fy14osti/60223.pdf>.

³⁴ "Blue Lake Wastewater Treatment Plant Facts," Metropolitan Council, September 2012, https://metro council.org/Wastewater-Water/Publications-And-Resources/ES_Bluelake2012_combined-pdf.aspx.

tion: performance materials made by transforming whatever are the right, abundant, local resources. The PI sincerely appreciates DOE-BETO's partnership, leadership, and vision to support this effort.

We appreciate the excellent point around synergy between gas-fed fermentation projects in the portfolio and look forward to potential cooperation with the National Renewable Energy Laboratory to tackle this exciting option. The reviewer will be pleased that discussions have already started on this front as a result of the Peer Review meeting.

We thank all the reviewers for their time, feedback, and suggestions.

BIOMASS ELECTROCHEMICAL REACTOR FOR UPGRADING BIOREFINERY WASTE TO INDUSTRIAL CHEMICALS AND HYDROGEN—BCU ALT

(WBS#: 2.3.1.205)

Project Description

The purpose of this project is to convert, by electrochemical processes, biorefinery waste lignin to industrial chemicals and hydrogen. We have developed nanostructured, nonprecious metal electrocatalysts that demonstrate high activity toward electrochemical depolymerization of biorefinery lignin to substituted aromatic compounds suitable for use in resins and resin binders. The relevance of this project includes use of actual biorefinery waste supplied from a pilot-scale lignocellulosic biorefinery, a controllable electrochemical process to target specific product classes and functionalities, and co-generation of hydrogen for energy stor-

Recipient:	Ohio University
Principal Investigator:	John Staser
Project Dates:	4/1/2016–3/31/2019
Project Category:	New
Project Type:	FY 2014—Biological and Chemical Upgrading: DE-FOA-0001085
Total DOE Funding:	\$1,472,724

age, all applied to biorefinery economics. The impacts include additional biorefinery revenue targeted toward reducing the cost of producing next-generation biofuel to make it cost-competitive with petroleum fuels. The challenges include potential low selectivity toward desired products, although we can exert some control over the oxidation mechanism by controlling electrochemical reaction energetics that have demonstrated higher yields of targeted product streams. The project outcomes include a continuous electrochemical process to convert biorefinery lignin to industrial chemicals and full TEAs integrating the electrochemical reactor into the biorefinery concept, including process flow diagrams and a market analysis.

Weighted Project Score: 8.1

Weighting: Approach–25%; Relevance–25%; Future Work–50%.

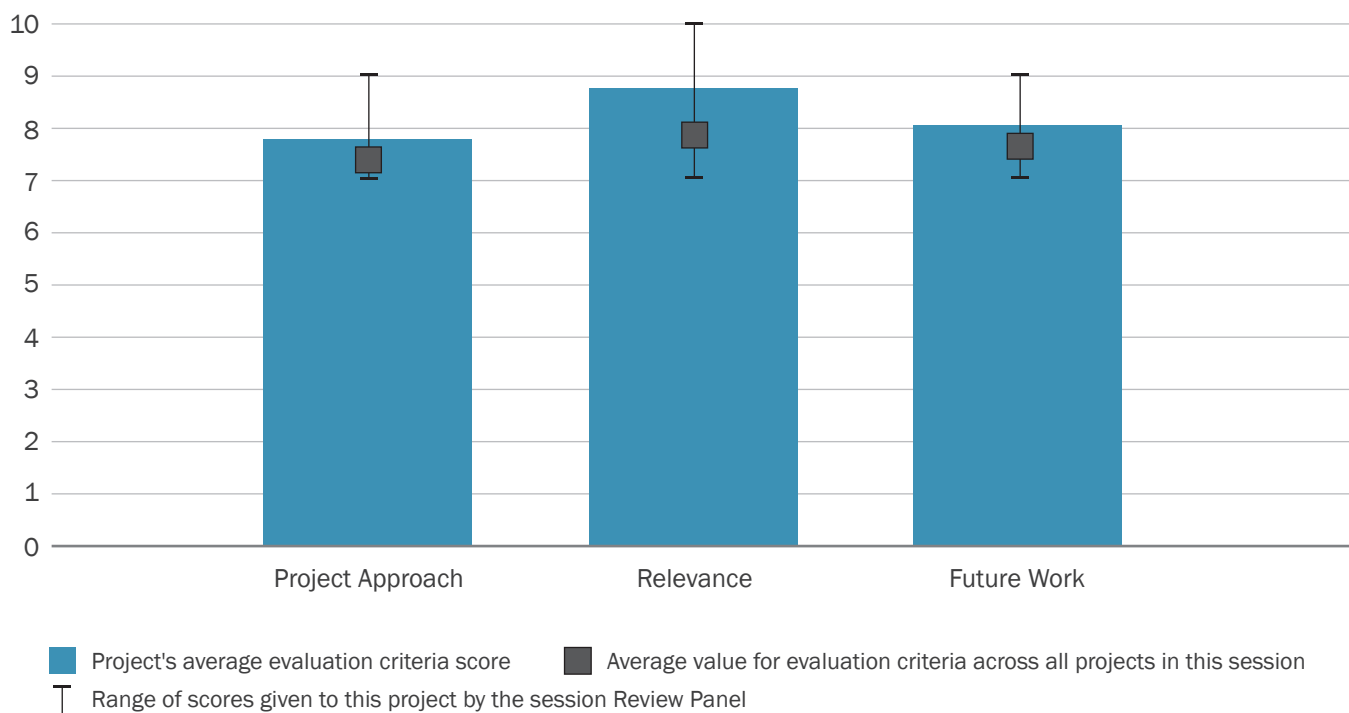



Overall Impressions

- The electrochemical catalyst is a novel approach to the lignin problem. Existing progress gives an early indication of a reasonable chance of success, and an end user is part of the project. There are a few other variables (lignin source, catalyst preparation/carrier, power usage/control) for which it would be good to present an understanding of the degree of variability they will give.

Testing of different catalysts carriers is a relevant variable for reaching the technical targets; the plan includes some diversity in lignin supply and catalyst production methods to show differences.

- Overall, this project has the potential to develop a new revenue streams for biorefineries through lignin valorization.
- The valorization of lignin beyond heating value is one of the industry “holy grails.” The complexity of lignin has been a major obstacle to finding a synthetic route to a higher-value product/utilization. This project has an original technical approach and an interesting commercial goal. The latter targeting the upgrade of lignin as a mixture of molecules rather than focusing on pure chemical makes it possible to greatly simplify post-processing and Q&A. The validation from an industrial partner is of great relevance. The TEA is not as developed as one may want, and I particularly missed an understanding of what the overall market potential is for the proposed enhanced lignin.

- This project, focused on aromatics production from lignin via electrochemical reaction, is unique and innovative. It addresses a waste not commonly looked at to form products not readily available from conventional feedstocks, using a process not often used in biomass conversion technologies, which are typically either biochemically or thermochemically based. The advantages of fine tuning reaction progress through control of the electrochemical potential, as well as operation at ambient conditions, could be a significant advance if it can be proven to perform as presented and if power requirements (especially for a full-scale version) are reasonable.

PI Response to Reviewer Comments

- We currently have one lignin source and are working to procure another. We hope to develop our process on both lignin sources in parallel.

Electrocatalyst performance and power consumption are both key drivers for this project. We have down-selected electrocatalysts that exhibit high current density (reaction rate) and high selectivity toward target products. We have also targeted running the electrochemical reactor at less than 1.6 volts, which we have achieved in practice. We chose that potential because it is lower than the potential required for water electrolysis, the primary electrochemical technique to generate hydrogen.

We would like to thank all reviewers for their help, as well as the support of DOE and our program managers. We are excited to work on this project with all of you.

In general, our primary deliverable is a full TEA incorporating product stream value and energy requirements. We will work with Hexion and the Biorefining Research Institute to complete the TEA by project’s end.

BIOGAS TO LIQUID FUELS AND CHEMICALS USING A METHANOTROPHIC MICROORGANISM

(WBS#: 2.3.2.102)

Project Description

Methane offers a promising, high-volume feedstock for fuel and chemical bioprocesses. Recent advances in gas-recovery technologies have facilitated access to previously inaccessible natural gas reserves, while biogas generated from AD of waste streams offers a versatile, renewable methane source. However, the gaseous state of methane makes for a lack of compatibility with current transportation and industrial manufacturing infrastructure, limiting its utilization as a transportation fuel and intermediate in biochemical processes. Methane bioconversion offers both methane valorization and greenhouse gas emission reduction potential, and it importantly offers a scalable, modular, and selective approach to methane utilization compared to conventional physical and chemical

Recipient:	National Renewable Energy Laboratory
Principal Investigator:	Mike Guarnieri
Project Dates:	10/1/2013–9/30/2017
Project Category:	Ongoing
Project Type:	Annual Operating Plan
DOE Funding FY 2014:	\$250,000
DOE Funding FY 2015:	\$150,000
DOE Funding FY 2016:	\$250,000
DOE Funding FY 2017:	\$400,000

conversion strategies. This project seeks to develop a viable path for conversion of methane to fuels and high-value co-products using a methanotrophic biocatalyst. Initial TEA identified carbon conversion efficiency as the key cost driver is such a process. We have employed genetic engineering and fermentation optimization strategies to directly target yield and methane oxidation rate enhancements to enable economically viable co-production of fuels and chemicals from methane. Our progress has generated the most carbon-efficient methanotrophic biocatalyst reported to date. This work is relevant to the Office

Weighted Project Score: 8.6

Weighting: For ongoing projects, there is equal weighting across all four evaluation criteria: Approach, Relevance, Accomplishments and Progress, and Future Work.

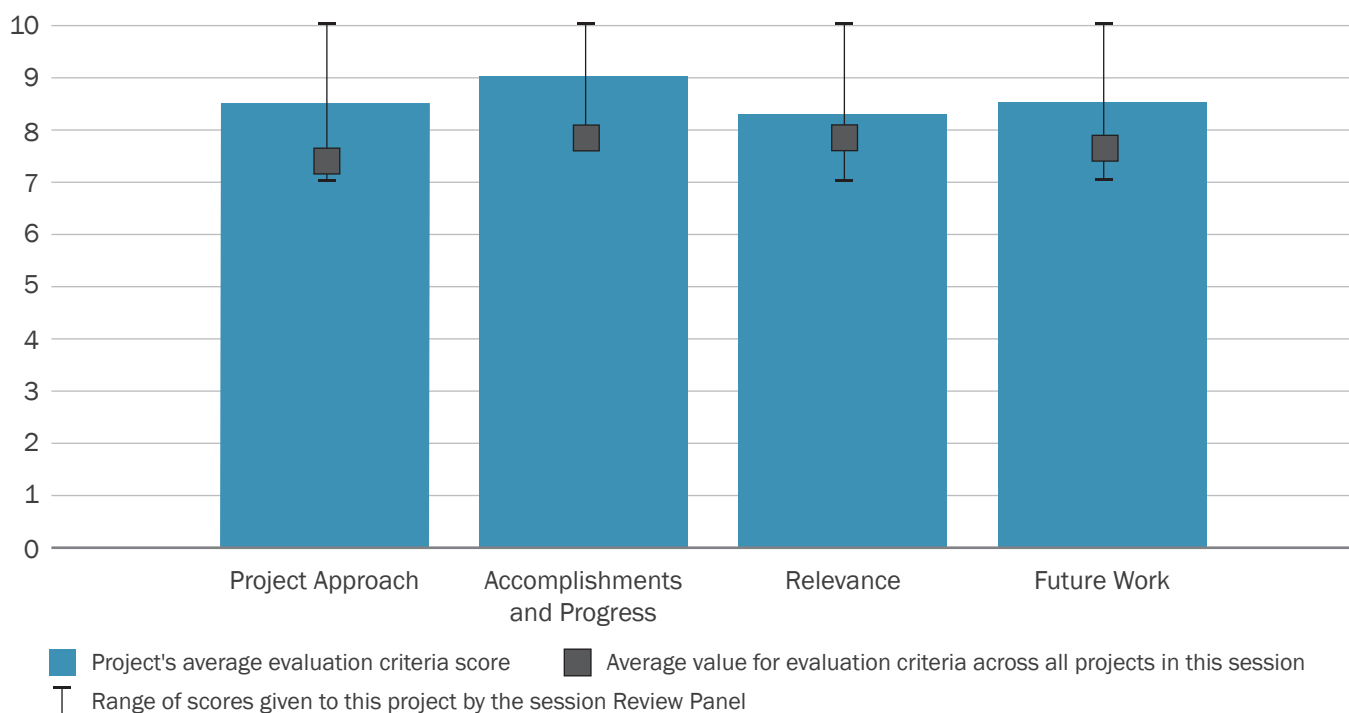

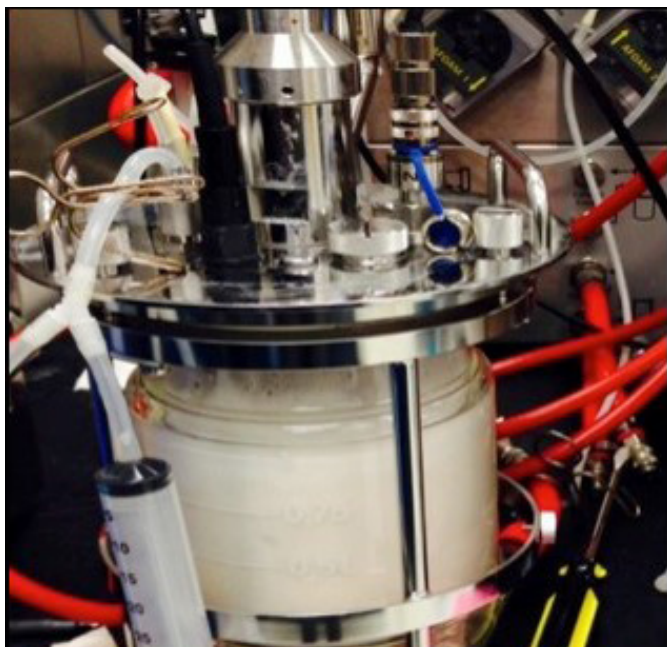

of Energy Efficiency and Renewable Energy's *Multi-Year Program Plan* for developing cost-effective, integrated WTE processes and biocatalyst development.

Overall Impressions

- This is an exciting project with great progress already. Toolbox production for methanotrophs is a very important work and very relevant for the application and biotech industry in general. The skilled and experienced project team has been very effective where others have made slow progress using relevant adjacent organism integrations.
- This approach to producing liquid fuels from biogas is sound and has the potential to be impactful.
- This is another project where I struggled. The use of methane as a carbon source is a potentially transformational technology, which cannot be ignored. Overall, the PI did an excellent job in presenting relevant technology of high scientific value and potential high commercial value. The work is of high quality, and the scores are only partially tempered by the considerations that follow, reflect it. I felt that the inclusion of biogas was more to justify the inclusion of this project under the BETO umbrella than a genuine

target from inception. A more general issue is whether it makes sense to develop specifically for biogas or if—once the technology for methane conversion has been proven—it is more sensible to incentivize the development of pipeline injection of biogas to make renewable methane available outside the immediate vicinity of an AD system. Pipeline injection is doable today with common off-the-shelf technologies. To use biogas, one needs to address the use of whole biogas (CH_4 and CO_2) and the scale issue. These aspects are recognized but not directly addressed. I recognize that the complexity of the problem justifies dealing first with methane and then with the whole biogas. Success with the first goal and not with the second is still of high overall relevance, although it may be argued that it stresses the envelope on the BETO relevance.

- This project is focused on improving uptake and conversion of methane from biogas via development of methanotrophic biocatalysts. While biogas itself is a useful fuel and, thus, its further conversion is not quite as critical as converting true waste feedstocks (e.g., manure, food waste, sludge), this project has value since liquid fuels are generally more flexible and more widely applicable than gaseous fuels. The project team appears to be well-managed and has produced some impressive genetic engineering results to date.

PI Response to Reviewer Comments

- We thank the reviewers for their positive feedback and constructive project review. As noted by the Review Panel, we feel the development and deployment of genetic tools accomplished under this project scope will have a significant impact upon the burgeoning methane biocatalysis space, as well as a broad impact on the BETO WTE Technology Area. To this end, our metabolic engineering efforts have generated the most carbon-efficient methanotrophic biocatalyst reported to date. The development of such enhanced methane biocatalysis strategies offers

a means to expand BETO's feedstock portfolio and represents a significant commercial opportunity to deploy WTE technologies. We also note the potential applicability of the design principles established here to conversion of natural gas, especially associated, remote, and/or stranded reserves. Additionally, we believe this project's efforts offer significant synergistic potential with other conversion platforms, importantly informing gas fermentation design principles and strain-engineering strategies related thereto.

Comprehensive TEAs have identified a viable path to commercialization via conversion of biogas-derived methane alone. However, we recognize the value in complete biogas utilization and have initiated efforts to develop biocatalysts with the capacity to valorize both biogas-derived methane and CO₂. Additionally, future efforts will target development of "downstream" biosynthetic capacity, enabling the generation of broad fuel- and chemical-intermediate suites from biogas. Our team is excited to continue these efforts and looks forward to continued progress in developing a viable biological biogas and natural gas conversion platform.

BIOGAS VALORIZATION: DEVELOPMENT OF A BIOGAS-TO-MUCONIC ACID BIOPROCESS

(WBS#: 2.3.2.201)

Project Description

Biological methane conversion offers a scalable, modular, and selective approach to biogas upgrading. To this end, the Biogas Valorization task targets the development of an integrated bioprocess to produce muconic acid from biogas. The project encompasses the development a novel methanotrophic biocatalyst and a high-efficiency, low-power fermentation configuration. Successful implementation of this target scope will enable facile integration with AD infrastructure and offer substantial biogas valorization potential. Importantly, developments here will also be applicable to an array of substrates, including syngas, natural gas, and CO₂. To date, the project has led to (1) the successful characterization of biogas derived from domestic substrates; (2) generation of novel muconate-pro-

Recipient:	National Renewable Energy Laboratory
Principal Investigator:	Mike Guarnieri
Project Dates:	6/1/2015–9/30/2018
Project Category:	Ongoing
Project Type:	FY 2014—Biological and Chemical Upgrading: DE-FOA-0001085
Total DOE Funding:	\$2,500,000

ducing methanotrophic biocatalysts; (3) development of genome-scale metabolic models for methanotrophic biocatalysts; (4) design and implementation of a high-efficiency, low power falling film reactor; and (5) generation of comprehensive techno-economic models for an array of methane feedstock inputs and organic acid outputs. This work is relevant to the Office of Energy Efficiency and Renewable Energy’s *Multi-Year Program Plan* for developing cost-effective, integrated WTE processes to produce bioproducts, and it explicitly targets BETO *Multi-Year Program Plan* barriers, including catalyst development, biochemical conversion process integration, WTE roadmap hurdle, and process intensification.

Weighted Project Score: 8.3

Weighting: For ongoing projects, there is equal weighting across all four evaluation criteria: Approach, Relevance, Accomplishments and Progress, and Future Work.

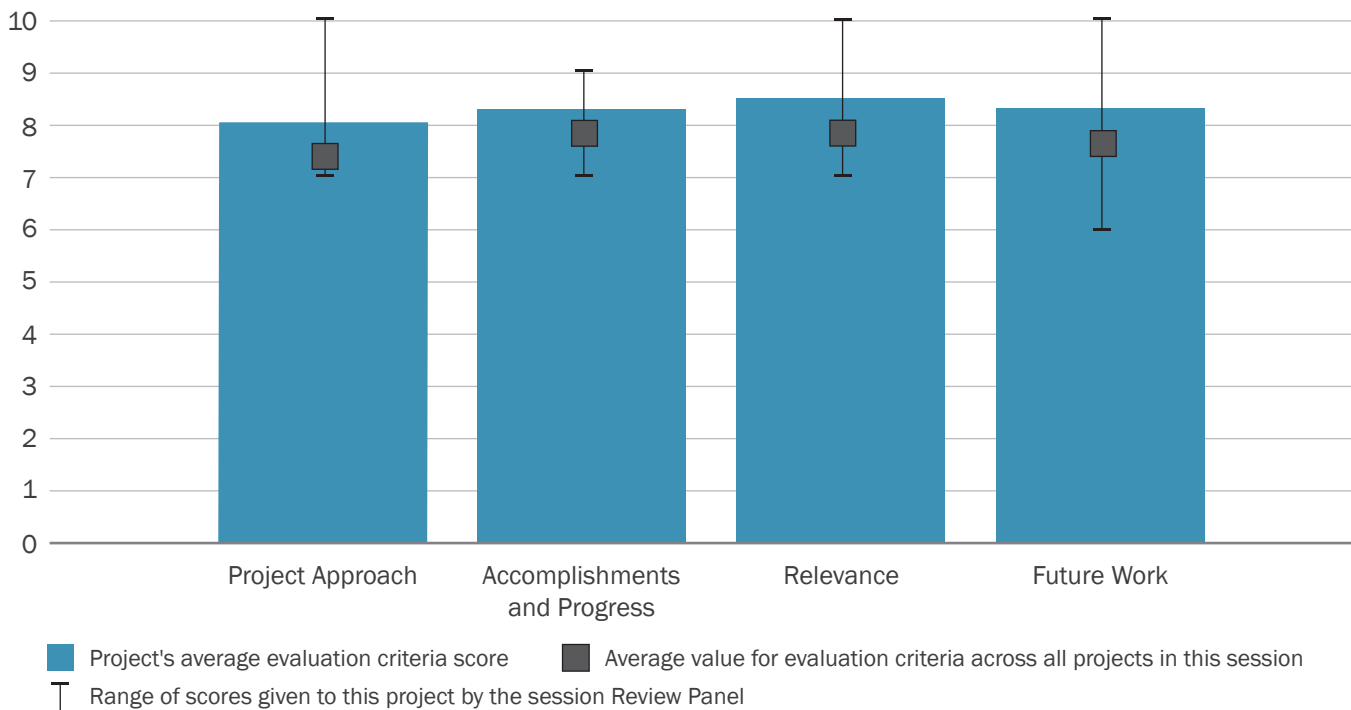



Overall Impressions

- This project has a good development pathway and has a lot of tools to achieve the targets. This is a very relevant work with large implications to industry and the Multi-Year Program Plan targets. Use of muconic acid as a target molecule gives it a general applicability to a large market.

As suggested by a panelist, a key performance indicator for viable cell population during the reactor operations may be relevant. The scalability of the reactor design is also something that will be good to understand in more detail.

It would be good to establish current position on the TEA goal and update for reporting. It would be good to know the go/no-go with reference to reactor design, as this complex design may be more expensive at scale than expected.

- The potential to increase the value of biogas through muconic acid production (a chemical precursor for many industrial chemicals and materials) is of value and could lead to increased revenue from AD.
- Besides some of the basic considerations regarding the actual relevance of biogas versus just regular

natural gas for this type of project, my key comment is that the TEA is still quite wanting. A better analysis could help make better sense of the opportunity afforded by an otherwise highly innovative project.

- This project is another one focused on genetic engineering of methanotrophs for use with biogas feed, although this project includes H₂S tolerance, a unique reactor type, and a different end product (muconic acid). The team appears to be well-managed and highly capable on the genetic engineering side, with achievements of significant results. The project incorporates good use and interaction with TEA models. Future integration of the reactor design and biocatalyst in real-time AD will be significant if successful.

PI Response to Reviewer Comments

We thank the reviewers for their complimentary and constructive feedback. As noted by the Review Panel, we are excited about the broad potential impact this work will have on BETO's nascent WTE Technology Area, as well as the larger biogas industry and the bioeconomy as a whole. This project offers a novel route to biogas conversion via an integrated approach, encompassing biogas generation, biocatalyst and bioreactor engineering, *in silico* analyses, and extensive techno-economic sensitivity analyses.

The proposed reactor design offers numerous advantages compared to conventional gas fermentation configurations, including low cost, modularity, low power input, minimal water (and related sustainability enhancements), and dramatically enhanced volumetric mass transfer metrics. Though beyond the current scope of work, we recognize the critical nature of examining reactor scalability. As detailed to the Review Panel, the potential scalability of the reactor design is grounded in strong design principles related to industrial paper manufacturing and high-speed paper coating technology. Additionally, we are currently considering the impact of the

reactor scale via comprehensive, integrated TEAs, which target viable productivity metrics at commercial scale. Following successful proof-of-principle demonstration at laboratory scale, future work will target process scale-up.

We are optimistic that this process configuration offers the potential for deployment in tandem with an array of biocatalysts for production of diverse secreted target product suites from waste-derived biogas. We look forward to evaluation of the proposed integrated bioprocess in our final award year.

ELECTROCHEMICAL MONITORING OF ANAEROBIC DIGESTION

(WBS#: 2.5.2.100-1)

Project Description

The project goal is to develop real-time, in-situ monitoring of microbiological bioprocesses for greater bioprocess control and stability by linking microbial physiology to electrochemical analysis. Specifically, we will address technology gaps that include inadequate process controls that often result in “sick digester syndrome.” This will allow us to redefine microbial physiology of bioprocesses in terms of electrochemistry and allow DOE’s Office of Energy Efficiency and Renewable Energy and BETO to accelerate near market integration for industrial or institutional applications through reduced stakeholder risk, lower operational cost, improved energy efficiency, and bioprocess control and reliability. We will evaluate mixed cultures for methane production. Savannah River National Laboratory will work in

Recipient:	Savannah River National Laboratory, Argonne National Laboratory
Principal Investigator:	Charles Turick
Project Dates:	10/1/2016–9/30/2019
Project Category:	New
Project Type:	Annual Operating Plan
DOE Funding FY 2014:	\$0
DOE Funding FY 2015:	\$0
DOE Funding FY 2016:	\$0
DOE Funding FY 2017:	\$159,000

conjunction with Argonne National Laboratory to define microbial activity as an electrochemical phenomenon and define bioprocesses perturbations and imbalanced conditions. This will include incorporation of electrochemical monitoring at larger scale at Argonne National Laboratory to demonstrate that real-time monitoring can be linked to feedback controls. Overall, we will develop and optimize novel electrochemical monitoring technology applicable to many systems, including various methanogenic mixed cultures, for real-time bioprocess

Weighted Project Score: 7.9

Weighting: Approach–25%; Relevance–25%; Future Work–50%.

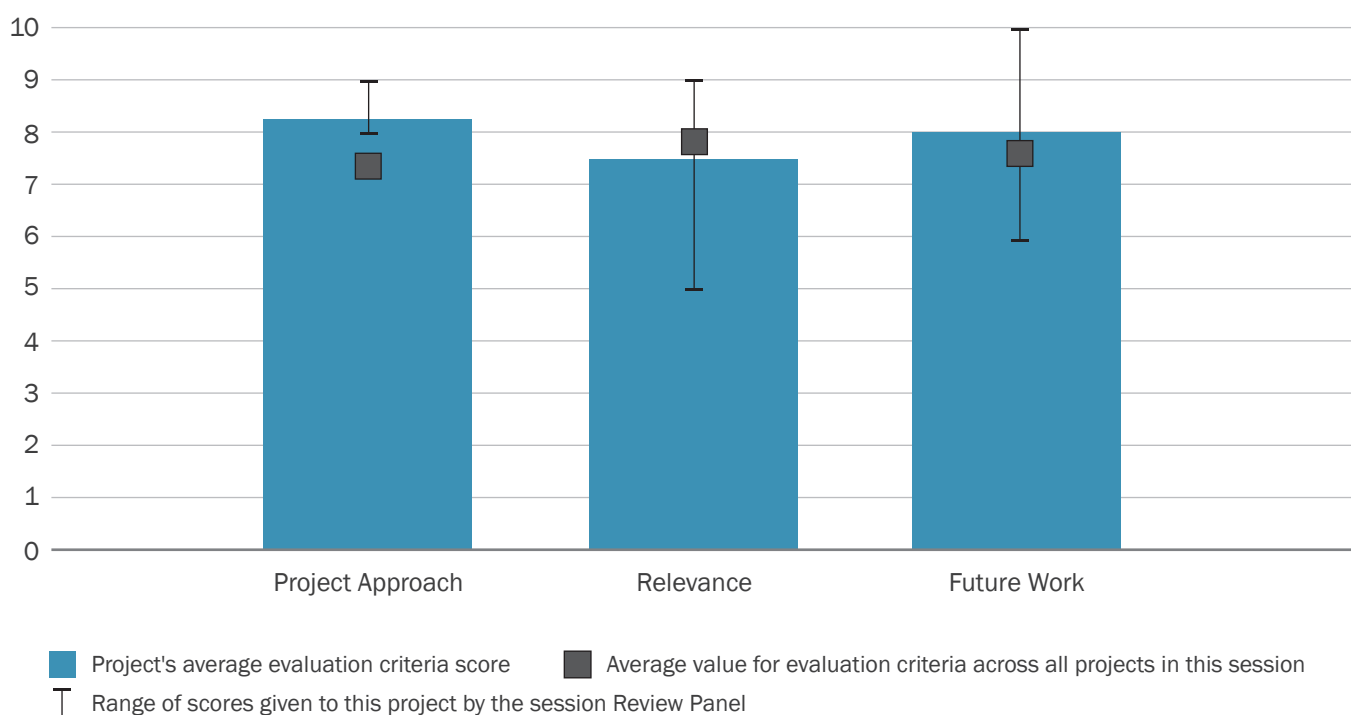

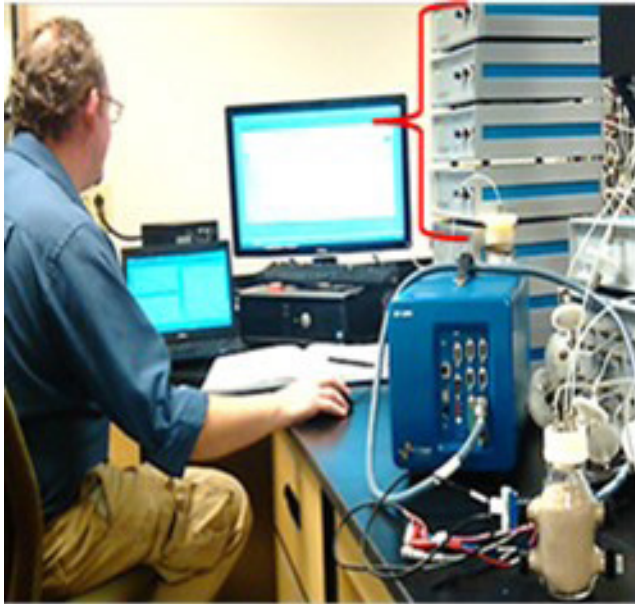

diagnostics, which will identify system upsets sooner than conventional approaches, leading to more stable and efficient operations.

Overall Impressions

- It is not completely clear what the advantage of this approach is compared to near-infrared reflectance, et al., already on the market because fouling made most other easier/cheaper methods ineffective. Perhaps some technology use cost comparison to alternatives, in addition to cost of failure if technology is not used, is needed. A panelist posed a question about how a probe testing just a local area can represent the entire AD; if the cost is significantly lower, maybe you should include multiple probes across the reactors.

I have some concern with the feedback approach to AD monitoring and control. Most often the issue is a change in feed; should a feed-forward approach also be of value to include in the goals? Several comments were made about what factors to evaluate (tannins, balance, et al.). Can these be defined for relevance with some sort of industry experts and prioritized to include in the project plan?

- This is a novel approach that has significant potential.
- This is a relatively inexpensive project, which, while not devoid of risks, if successful can deliver immediate value to the industry and then enable its further development.

The successful completion of this project is likely to be only the beginning of a longer process to provide a technology that performs at scale. Some of this follow-up work should be carried out in the context of a possible commercialization as I believe that if the technology can be proven at a reasonable scale, there will be no shortage of opportunity for commercialization. It is important that the PI identifies what that scale is or sets up the program for those follow-ups.

- This project looks to correlate electrochemical and other data gathered through sensors to assess digester performance in real time. If successful, this approach can provide a fast and relatively low-cost method to correct imbalances in reactor biological behavior before the batch becomes unrecoverable, though it is not clear at the present time whether even this data could be gathered fast enough to do so. Nevertheless, the project potential benefits are sufficiently worthwhile to pursue.

PI Response to Reviewer Comments

Existing on-line methods and sensors for CO₂, CH₄, and H₂ analysis, such as near-infrared reflectance, are useful in providing information about current reactor status. However, this is not always straightforward since gas liquid partitioning in digesters can be quite dynamic. Additionally, declines in biogas production often represent preexisting problems that may be too late to fix. We feel that one of the significant advantages of our technical approach is the potential for abundant inexpensive data that could incorporate digester sampling as many as four times per hour.

Our approach incorporates evaluation of cellular viability such that issues related to upset conditions will likely be detected in the microbial community prior to metabolite buildup in the reactor. Our future studies plan to incorporate infrared detection for CO₂, H₂, and CH₄ along with electrochemical and digester environment analyses, and we expect the study results to give us information about any potential time lags related to reactor performance and analytical platforms. Our technical approach has the potential for abundant inexpensive data that could incorporate digester sampling as many as four times per hour, if needed.

We will evaluate the application of multiple electrodes as well as electrode design to determine if we can obtain a better representation of bioprocess activity. Multiple electrodes operated simultaneously may be prone to interference through crosstalk. We will keep this in mind as we evaluate designs and configurations. Although one of the reviewers suggested feed-forward analyses, that topic is out of our project scope presently. However, it is an excellent technical challenge that we will consider.

Elevated H₂ and short-chain fatty acids, widely varying feedstocks composition and volume, and elevated organic loading rates are likely the more common inhibitors encountered throughout the industry and are a focus of our study. We will address other inhibitors that may be more specific to particular waste streams (e.g., tannins in agricultural wastes) following interactions with reactor operators that will allow us to categorize them based on relevance. The project team has an established relationship with the AD users and plans to get their guidance and advice during the project. Our ultimate goal is to test performance of new sensors at the field-scale digesters.



DEMONSTRATION AND MARKET TRANSFORMATION



TECHNOLOGY AREA



CONTENTS

INTRODUCTION.....	502
DMT OVERVIEW	502
DMT REVIEW PANEL	505
TECHNOLOGY AREA SCORE RESULTS.....	506
DMT REVIEW PANEL SUMMARY REPORT	507
DMT PROGRAMMATIC RESPONSE	509
FIRE STANDARDS CODES AND PREVENTION IN IBRS	513
RENEWABLE ACID-HYDROLYSIS CONDENSATION HYDROTREATING (REACH) PILOT PLANT	516
LIBERTY—LAUNCH OF AN INTEGRATED BIOREFINERY WITH ECO-SUSTAINABLE AND RENEWABLE TECHNOLOGIES IN YEAR 2009	518
BROOKHAVEN NATIONAL LABORATORY BIO-OIL DEPLOYMENT IN THE HOME HEATING MARKET	521

INTRODUCTION

During the Demonstration and Market Transformation (DMT) session, six external experts from industry, academia, and other government agencies reviewed a total of four projects.

This review focused on DMT's integrated biorefinery (IBR) portfolio and addressed a total U.S. Department of Energy (DOE) investment value of approximately \$93.7 million, which represents approximately 13.3 % of the Bioenergy Technologies Office (BETO or the Office) portfolio reviewed during the 2017 Project Peer Review. The Co-Optimization of Fuels and Engines (Co-Optima) consortium project, which is part of the DMT portfolio, was reviewed in a separate session due to the complexity and scale of the work. The Co-Optima review addressed a total DOE investment value of approximately \$50 million, with BETO contributing \$26 million and the Vehicle Technologies Office contributing \$24.5 million (fiscal year [FY] 2015–2016 spending).

During the Project Peer Review meeting, the principal investigator (PI) for each project had 30 minutes to provide an overview of their project and its status and respond to questions from the Review Panel.

The Review Panel evaluated and scored projects based on their project approach, technical progress and accomplishments, relevance to BETO goals, and future plans. This section of the report contains the results of the project review, including full scoring information for each project, summary comments from each reviewer, and any public response provided by the PI. This section also includes overview information on the DMT Program, full scoring results and analysis, the Review Panel's summary report, and BETO's programmatic response.

BETO designated Borka Kostova as the DMT Technology Area Review Lead. In this capacity, Dr. Kostova was responsible for all aspects of review planning and implementation.

DMT OVERVIEW

DMT's goal is (1) to de-risk bioenergy production technologies through validated proof of performance at the pilot, demonstration, and pioneer scales and (2) to conduct activities that will transform the bioenergy market by reducing or removing commercialization barriers. This is achieved through public-private partnerships that build and operate IBRs and through projects focused on addressing technology, biofuels and bioproducts distribution infrastructure, and end-use market barriers and opportunities. DMT helps to address the links of the bioenergy supply chain and works to enable a robust demand for end products

The DMT Program manages a diverse portfolio of IBR projects, which is focused on the scale-up of biofuels production.

In FY 2015, DMT managed a portfolio of 28 projects, including 2 at pioneer scale (plus 3 pioneer-scale projects co-managed within Defense Production Act), 7 at

demonstration scale, 12 at pilot scale, and 4 additional projects selected under at the Innovative Pilot funding opportunity announcement (FOA) to support aviation and military fuel applications. The conversion pathways addressed included 13 biochemical technologies, 7 thermochemical technologies, and 5 algal technologies. The active portfolio included 13 projects focused on cellulosic ethanol, 12 projects focused on renewable hydrocarbons, and 1 project focused on renewable intermediate biochemical products.

The majority of these projects were funded by the American Recovery and Reinvestment Act of 2009 and were completed by the end of FY 2015.

In FY 2016, 8 projects from the prior portfolio of 28 projects were still ongoing: two at the pioneer scale producing cellulosic ethanol, three co-managed within the Defense Production Act producing renewable diesel and jet fuel, and three at a small pilot scale producing renewable hydrocarbons, such as military-specification diesel and aviation fuel.

Another important element of the DMT portfolio is the Co-Optima consortium project. The Co-Optima initiative is a collaborative effort between the Vehicle Technologies Office, BETO, nine national laboratories, 13 universities, and numerous industry and government stakeholders. Co-Optima's coordinated engine and fuels research and analysis are providing the framework for the co-development of fuel and engine technologies that, when used in tandem, offer the greatest combination of efficiency and performance. BETO explicitly seeks to identify biomass-based blendstock options since they have the potential to increase domestic fuel sources and provide additional environmental, social, and economic benefits. The Co-Optima portfolio was reviewed in a separate session due to the scale and complexity of the work.

DMT Support of Office Strategic Goals

The DMT Technology Area's strategic goal is to contribute to (1) developing commercially viable bioenergy technologies through public-private partnerships that build and validate pilot-, demonstration-, and pioneer-scale IBRs and (2) developing supporting infrastructure to enable a fully operational and sustainable biomass-to-bioenergy value chain in the United States.

DMT focuses on reducing risk to the consumer and the private sector and on helping overcome challenges to financing the follow-on expansion of the industry, which

is required to make a major contribution to our nation's energy independence and security. In addition, DMT facilitates developing novel methods for expanding the end-use market for biofuel and bioproducts.

DMT Support of Office Performance Goals

A specific DMT goal in support of BETO's performance goals is as follows:

By 2017, validate a mature technology modeled cost of cellulosic ethanol production, based on actual IBR performance data, and compare to the target of \$2.65/gallon ethanol (\$2014).

DMT Approach for Overcoming Challenges

Current DMT activities generally fall into five categories: analysis and sustainability, technology interface, feedstocks, IBRs, and infrastructure and end use. DMT activities are performed primarily by industry partners, with national laboratories and universities also making significant contributions.

Below, BETO has identified the market and technical challenges and barriers for which improvements are crucial to reaching DMT program goals.

Market Challenges and Barriers

- Inadequate feedstock supply chain infrastructure
- High risk of large capital investments
- Codes, standards, and approval for use
- Cost of production
- Offtake agreements
- Uncertain pace of biofuel availability
- Biofuels distribution infrastructure
- Lack of acceptance and awareness of biofuels as a viable alternative

Technical Challenges and Barriers

- End-to-end process integration
- Risk of first-of-a-kind technology
- Technical risk of scaling
- Engines not optimized for biofuel

Analysis and Sustainability

Both project-specific and portfolio-wide evaluations assess progress toward objectives and sharpen the focus of DMT strategies on the areas with the highest potential impact to the industry. These evaluations, which encompass a broad range of technical performance and economic, social, and environmental sustainability metrics, are updated annually to reflect developments within each project and the industry. Specific metrics include process performance by unit operation; financial data, including pro forma and actual capital and operating costs; and sustainability metrics, including water usage, life-cycle greenhouse gas emissions, and jobs created. These data are used to monitor progress against goals, assess the current state of technology for various biomass-utilization technologies, and determine the projected commercial impact of various projects.

Technology Interface

DMT projects integrate broad sets of technologies from Feedstock Supply and Logistics and Conversion Research and Development (R&D). Technology interface activities help identify (1) technologies that are ready for piloting and scale-up, (2) entirely new feedstock logistics systems or conversion technologies, or (3) improvements to a smaller set of unit operations. In addition, new challenges discovered during scale-up are shared in a feedback loop with R&D areas to facilitate continuous learning and proactively address improvement opportunities.

Feedstocks

Biomass feedstock is an essential primary input to every IBR, and efforts to improve supply and logistics systems

are essential for commercial operations. These activities span both terrestrial feedstock and algal feedstock systems to identify areas for improvement in feedstock supply and logistics systems and in the development of advanced feedstock logistics systems.

Integrated Biorefineries

Validating performance at integrated pilot, demonstration, and pioneer scales is essential to de-risk technology and enable financing that will catalyze the transition to large-scale renewable fuel and bioproducts production. Operations at each of these scales systematically address many of the market and technical barriers previously identified. Integrated pilots prove the end-to-end process and develop engineering modeling tools. Demonstration-scale facilities then allow for more optimized equipment specifications and can manufacture products for commercial acceptance, which can lead to offtake agreements for the pioneer plant. Finally, pioneer plants prove continuous economic operation with large-scale supply chains. Operational data at each scale are also used to address many other barriers, including sustainability.

The success of IBR projects is expected to help to de-risk the technology to facilitate future commercial financing for biofuels, bioproducts, and biopower production. Analogous to the petrochemical industry's development of refinery infrastructure, biorefinery projects showing success should translate into better financing potential.

Infrastructure and End Use

In addition to the significant risks involved with scaling up new biorefinery technology, other market barriers

related to infrastructure and end use also limit advanced biofuel production. Efforts in this area focus on enabling higher rates of renewable fuel usage in current markets while addressing barriers for expansion into new markets, such as home heating oil. Specific efforts in this area are to establish linkages early in the R&D cycle of both fuels and engines. Co-development of fuels and engines could result in expanded markets for renewable fuels, improvements in vehicle engine efficiency, and reductions in life-cycle greenhouse gas emissions.

BETO works closely with DOE's Vehicles Technology Office (1) to identify the opportunities and challenges

associated with the development of new fuel specifications and (2) to assist stakeholders in developing and deploying optimized vehicle systems, new fuel compositions, and compatible infrastructure needed to achieve increased advanced biofuels use in the U.S. transportation system. Specific activities are focused on identifying critical fuel properties needed to optimize performance of advanced spark-ignition and compression-ignition engines, identifying biomass-derived molecules and mixtures with properties that maximize performance of advanced engines, evaluating pathways to production, and modeling the fuel blending behavior.

DMT REVIEW PANEL

The following external experts served as reviewers for the DMT Technology Area during the 2017 Project Peer Review.

Name	Affiliation
Mike McCurdy*	ICF International, previously Leidos
Alan Propp	Propp and Associates
Kerri Neary	DOE Loan Programs Office
Mark Penshorn	RES Kaidi
Danielle Sexton	Harris Group
Andrea Slayton	Northrop Grumman

* Lead Reviewer

TECHNOLOGY AREA SCORE RESULTS

Average Weighted Scores by Project

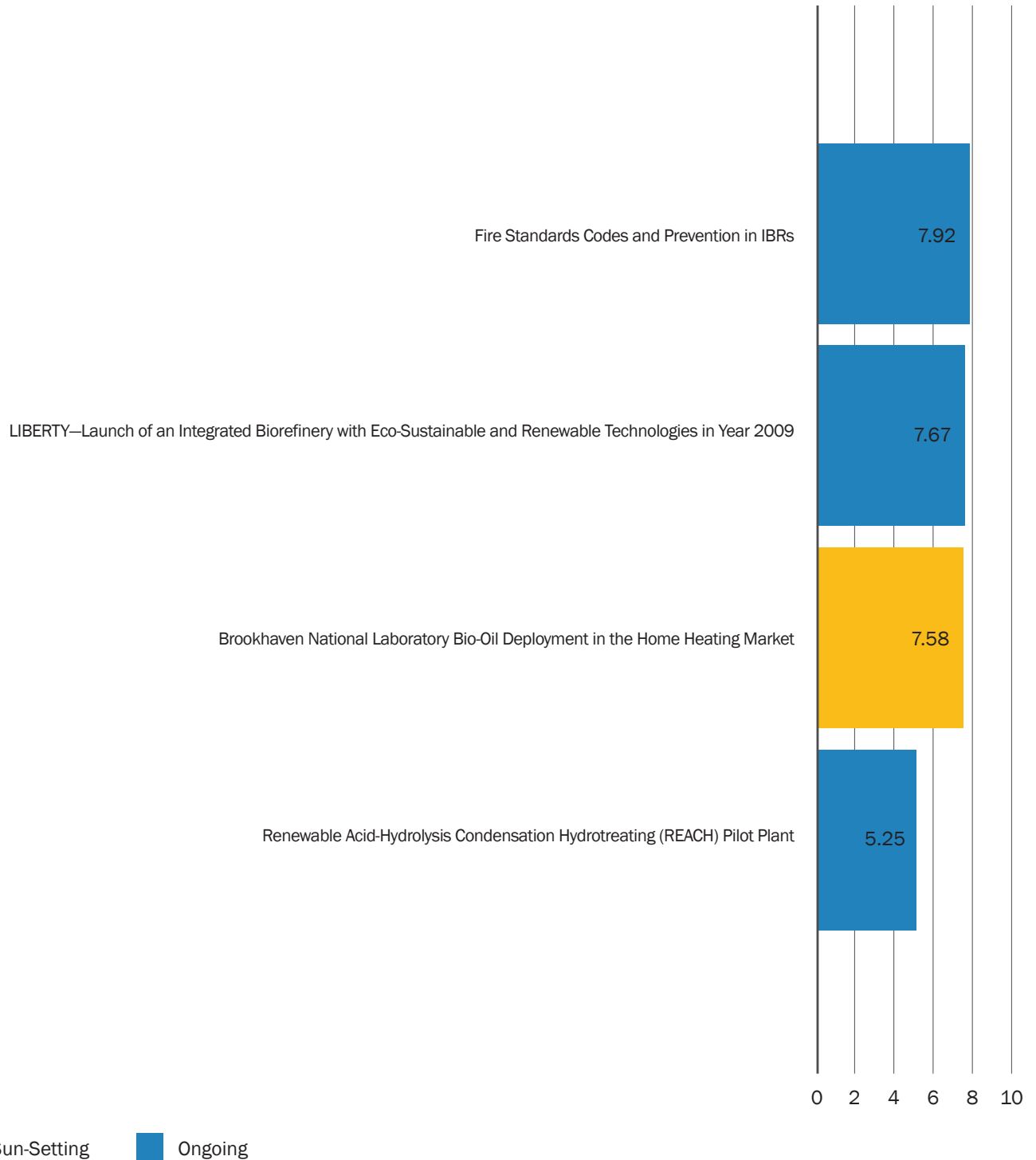

■ Sun-Setting ■ Ongoing

DMT REVIEW PANEL SUMMARY REPORT

Prepared by the DMT Review Panel

Overview

The DMT team provides the final critical link between publicly supported R&D and private-sector commercialization of new and innovative technologies. Key barriers to the adoption of the technologies remain, including conversion costs, feedstock, and distribution infrastructure; industry human capacity building; achievement of stable/mature operations; and financing of pioneer facilities. In addition to the projects presented within the DMT Peer Review session, the DMT portfolio includes a comprehensive project named Co-Optima, which aims to develop future fuels and engines together. Due to the complexity of Co-Optima, it was presented in a separate Peer Review session.

On behalf of the Review Panel, we would like to thank both the DOE DMT team for the invitation to review the presentations and the presenters who took the time out of their busy schedules to summarize their projects to the public at large.

Impact

The DMT team has had a substantial impact on the development of the bioenergy industry by (1) investing in pioneer commercial facilities where uncertainty in the time and cost required to achieve mature operations has limited the private funding options, (2) supporting the testing of new processes at the pilot scale so that the technical feasibility and economics at the commercial scale can be established, and (3) addressing cross-technology issues with material handling, fire threats, and other issues that introduce uncertainty and risk throughout the space.

The POET-DSM Project LIBERTY pioneer plant is a perfect example of the impact of the DMT Program. Project LIBERTY represents the final step to commercialization of the technology, where stable sustained operations are demonstrated for both future plant own-

ers and their lenders. Without an operating commercial analog to reference, lenders have been hesitant to provide financing without public-backed credit subsidies, such as loan guarantees and grants, to cover technology risks. As an operating facility, Project LIBERTY will provide the data necessary to assess the technology risks and allow owners and lenders to price loans based on conventional market risk rather than technology issues. We cannot understate the importance of this milestone. A commercially proven cellulosic biofuel design would allow the United States to unlock billions of gallons of domestic energy, revitalize rural economies, and create thousands of good-paying jobs in some of our country's most disadvantaged areas.

DMT's impact in pilot-scale testing has been limited over the past year; Mercurius Biofuels' project is the only active pilot-scale work in DMT. The Review Panel would like to encourage BETO to support more technologies at the pilot scale, as the pace of technology development is at its peak, and the pilot scale can be a particularly challenging stage for companies seeking financing. That being said, the Review Panel acknowledges and fully supports BETO's requirements for projects to make measurable progress in a timely manner and to provide the private-side cost-share funds promised at the time of award. These requirements are important to ensure a timely return on BETO's investments and to confirm that technologies have private-side support for eventual commercialization.

The Oak Ridge National Laboratory (ORNL) Fire Standards Codes and Prevention in IBRs project fits well into the third category of cross-sector issues that may have a limited impact on any one project but have a significant impact on the bioenergy sector as a whole. Fires have been a pervasive problem for the industry to date, and many of the Peer Review Panel members have witnessed or experienced fires at their projects. This project has the potential to significantly advance the state of technology for fire protection; there is currently very limited information on the subject, and each separate project has had to figure out proper fire protection methods using a trial-and-error process. By summariz-

ing this information so that it may be used by farmers and engineers early in the project, projects can eliminate costly mistakes during project development. Additionally, the actual fire testing will generate information for the fire protection engineers to minimize damage from fire while the plants are in commercial operation.

Innovation

The DMT Program contains innovative process types and methods to improve the availability of the technologies at scale. The Peer Review Panel thought that the DMT team was wise to maintain the technology diversity of the portfolio, so as not to over-concentrate investments in one area. The investment in Mercurius Biofuels' Renewable Acid-Hydrolysis Condensation Hydrotreating (REACH) liquid-phase conversion technology is an example of supporting a diverse set of technologies with commercial potential. The other, more subtle innovation is the manner in which POET-DSM's Project LIBERTY has been addressing unforeseen startup issues to improve the availability of the Project LIBERTY plant. It takes a significant amount of effort to address issues when dealing with hundreds of tons of biomass per hour, and the Review Panel commends POET-DSM's Project LIBERTY and the DMT team for their efforts in this area.

As mentioned before, the Review Panel would like to encourage BETO to support larger-scale testing of technologies outside enzymatic hydrolysis to drive some of the other innovative technologies development. While the Panel would have liked to see more projects in the DMT Program, we do acknowledge that the Project Definition for Pilot- and Demonstration-Scale Manufacturing of Biofuels, Bioproducts, and Biopower (PD2B3) FOA and IBR Optimization FOA may provide additional opportunities for larger-scale testing.

Synergies

In the Review Panel's opinion, projects in the space have significant synergies outside of the core technologies, and these synergies provide an opportunity for BETO to have a positive impact to the industry at large.

The Panel identified three areas with significant potential synergies: biomass handling/preprocessing, fuels qualification, and identification of market opportunities. Handling and sizing biomass has been a significant challenge for most of the industry participants to date; some investments in R&D at equipment vendors could enable single investments to benefit multiple projects. Additionally, different plants that use the same equipment tend to form working groups to share knowledge on the best ways to operate and maintain the equipment. This accelerates the maturation of the technology, increasing the availability of the projects and, ultimately, their profitability. While we did note that BETO team members informally worked to capitalize on the synergies between the projects in the portfolio, the Panel thought that it may be beneficial to establish more formal links between projects with potential synergies. For example, the Brookhaven National Laboratory Bio-Oil Deployment in the Home Heating Market project identified a large market with lower barriers to entry, but the success of the project was limited due to the unavailability of bio-oil for testing by potential off-takers.

Focus

If at all possible, the Panel would like to see DMT fund some additional projects, as there are many more potential technologies in the space, and the two current projects only cover a small portion of the total. In the plenaries, the DMT team noted that six additional projects were awarded grants under the PD2B3 FOA, and that the DMT team would like to extend additional awards under the IBR Optimization FOA in 2017. We support the replenishment of the portfolio and commend the DMT team for funding these new projects. In addition to the aforementioned investments, the Panel believes that some focused investments in biomass preprocessing and fuels qualification could potentially assist a number of companies in the space.

Commercialization

The Panel noted that one of the key commercialization metrics is availability, and that the best way to identi-

fy items that reduce availability is to operate plants for extended periods of time. The Panel thought that more focus on the operation of existing assets, rather than construction, may allow BETO to stretch their budgets in this area. For example, the Panel thought that Mercurius' revised plan to utilize existing assets at Michigan State University's Bioeconomy Institute rather than constructing them for the project would have been a more rational and cost-effective approach if done at project inception.

The Panel also noted that it may be beneficial for BETO to favor those pilot plants that will be operated for more than 1,000 hours. While 1,000 hours is generally viewed as sufficient to achieve stable operation and derive useful data on the yield of the process, this amount of time is insufficient to identify long-term operations and maintenance issues that would be encountered at commercial scale. In the absence of a demonstration-scale plant in between the pilot and commercial scale, successful developers like POET-DSM's Project LIBERTY have operated their pilot plants for tens of thousands of hours to identify and correct these issues. While we acknowledge the criticality of the pilot plant testing, we do also acknowledge that certain unit operations cannot be properly tested at pilot scale due to differences in functionality and operating characteristics; thus, testing at or near full scale is a commercial reality for developers in the space.

Recommendations

When asked to identify the three most important recommendations that would strengthen the DMT portfolio, the Review Panel has the following recommendations:

Recommendation 1: More Funding for DMT Projects

Getting more sufficiently funded projects into the DMT portfolio will be key, as it is likely that not all of them will be successful. Acknowledging that these projects are expensive, it is critical to have a sufficient number so that there are enough successful outcomes so that taxpayers can see a return on their R&D investments. Additionally, we note the criticality of proper funding/resourcing of the projects, as dividing the existing limited budget on an increased number of projects could result in under-resourced projects with bad outcomes.

Recommendation 2: Focus National Laboratories' Efforts on Availability Issues (versus yield) outside the Core Technologies

Efforts such as the ORNL Fire Standards Codes and Prevention in IBRs project and the Idaho National Laboratory biomass handling assistance to DuPont have the potential to dramatically increase the success rate of individual technologies while having a positive impact industry-wide.

Recommendation 3: Develop FOAs that Use Existing Assets for Testing and Test for Longer Periods

"Capital-light" approaches with existing assets reduce the amount of resources spent developing a green field space and can yield more rapid results than projects that include construction.

DMT PROGRAMMATIC RESPONSE

Introduction/Overview

BETO would like to thank the Review Panel for their time and active participation in the DMT session, as well as the panelists and Steering Committee for pro-

viding their feedback during the Project Peer Review meeting in March 2017 and the Program Management Review meeting in July 2017. We appreciate the Panel's insightful and engaged review of the DMT projects. The reviewers all provided in-depth and constructive recommendations that can be used to inform the DMT Technology Area's path forward in the coming years.

At the 2015 Peer Review, the DMT session Review Panel reviewed a total of 19 projects from the DMT portfolio. Many of these projects were funded through the American Recovery and Reinvestment Act of 2009 and were completed prior to the 2017 review. In 2017, the Panel reviewed four projects. Two of these were IBRs, and two were market transformation–focused projects from the national laboratories. BETO would like to thank the PIs for taking the time to present their findings and progress and for their hard work in executing these innovative projects.

At the 2015 Peer Review, reviewers provided the following recommendations to the DMT Program:

- Increase the DMT portfolio’s diversity and funding level—this is essential to maintain the momentum established thus far and to show commitment to developing technologies
- Focus on primary products that are not fuels
- Give consideration and preference to projects that co-locate with existing facilities, based on potential benefits of co-location
- Consider a break-even scenario, instead of positive cash flow, for pioneer commercial-scale projects
- Continue to support promising American Recovery and Reinvestment Act projects.

The DMT Program has made efforts to incorporate these recommendations into its actions over the past 2 years, and since the 2015 Peer Review, we have released two FOAs. These FOAs are geared toward furthering the commercialization of biofuels through supporting pilot- and demonstration-scale facilities and biorefinery optimization in order to lower the technical and financial risks facing IBRs. The 2017 Review Panel noted that the DMT portfolio was smaller than in years past, but the Panel recognized that these recent FOAs will expand the portfolio significantly.

The Panel commented on the significant impact that the DMT portfolio has had on the commercialization of biofuels both through the POET-DSM biorefinery and

through market transformation projects, such as ORNL’s Fire Standards Codes and Prevention in IBRs. The Panel said that the POET-DSM LIBERTY demonstrated the viability of a commercial-scale facility and that its learnings will drive further R&D. The ORNL work is addressing an industry-wide issue, as nearly every IBR has experienced a biomass fire in some capacity. The Panel believes that, in the context of commercialization, it is important that future pilot plants are operated beyond the current goal of 1,000 hours, as existing facilities are still experiencing issues with continued operation. DMT supports this point and agrees that reliable, continuous operation is necessary for the commercialization of biofuels. We appreciate this feedback and are working to address this point through current and future plans.

The PD2B3 FOA incorporated language that set aside funding specifically for testing facility operation at pilot- and demonstration-scale biorefineries. The recent IBR Optimization FOA focused on enabling the reliable and continuous operation of biorefineries. These two funding opportunities will work to address areas identified by the Panel, but DMT will continue to support commercialization of biofuels and bioproducts in future planning.

Although the 2017 DMT portfolio was smaller than in years past, the Panel recognized that it was growing again and had incorporated a strong innovative technology investment strategy that included both breadth and depth. The Review Panel also commended BETO’s stage-gate review process in that it rewards progress rather than effort. This pushes projects to grow while also reducing unnecessary spending. DMT’s adherence to active project management procedure and stage-gate reviews ensure that projects do not receive funds prematurely. This process protects taxpayer funds and ensures that all projects are managed uniformly. DMT will continue to adhere to active project management procedure in future projects but will also take additional steps to validate biofuel technologies prior to project kickoff. These steps will further ensure that DMT funds are well-managed and support technologies that have a greater chance of success.

The Panel said that one of DMT's stronger areas was its synergies with the biofuels industry, particularly in biomass handling and preprocessing, improvement of conversion yields, fuels qualification, identification of market opportunities, and assistance with financing challenges. The Panel stated that while BETO works informally to capitalize on synergies within the program, it may be beneficial to establish more formal links between BETO projects. BETO and the DMT Program recognize the potential for greater collaboration between existing projects and will consider incorporating this as we develop future plans for both competitive and non-competitive funding. The Feedstock-Conversion Interface Consortium is also a strong example of where future synergies between stakeholders and projects can be developed.

The Panel concluded that one of the greatest limitations to DMT achieving its goals is the program's funding level. While the Panel recognized that DMT's funding may be outside of its control, they proposed ways that DMT could use existing funds to their greatest potential. This point was also included in their overall recommendations, and the Panel recommended that the program could manage to support the industry despite limited funding by promoting projects that utilize existing assets and infrastructure. By utilizing existing infrastructure, the capital necessary for a project could be dramatically decreased. We recognize the limitations of a decreased funding level as it applies to all projects, especially those with a capital-intensive construction phase, and appreciate the Panel's insight into how we can continue to impact biofuels commercialization at any level of funding. DMT will consider implementing this suggestion for future opportunities.

In addition to program-specific feedback, the Review Panel provided project-specific feedback. The PIs and their project teams will work to incorporate this feedback as they continue forward with their projects.

To conclude its review, the Panel provided three overall recommendations for the DMT Technology Area that, if implemented, would have the greatest impact on the portfolio and its ability to achieve its goals:

Recommendation 1: More Funding for DMT Projects

The Panel recommended awarding a greater number of DMT projects based on the knowledge that not all projects will be successful. While recognizing that DMT projects tend to require greater levels of funding than initial R&D, the Panel recommended that the DMT portfolio house more projects to ensure a greater probability of successful outcomes. This approach would ensure that the biofuels industry continues to move forward under government support and that taxpayer funds are providing a return on R&D investments.

DMT agrees that by both expanding and diversifying its portfolio, biofuels and bioproducts could see a greater number of successes, which in turn decreases risk to private investment, further supporting the industry. We greatly appreciate this recommendation and, while the DMT portfolio continues to expand under recent funding opportunities, we will continue to prioritize this growth in future plans.

Recommendation 2: Focus National Laboratories' Efforts on Availability Issues (versus yield) outside the Core Technologies

The Panel's recommendation to focus national laboratory efforts on availability issues arose from the impacts of efforts such as ORNL's Fire Standards Codes and Prevention in IBRs project and Idaho National Laboratory's biomass handling assistance to DuPont. These efforts have the potential to dramatically increase the success rate of the individual technologies while having a positive impact industry-wide. In addition, these projects have historically required less funding than a biorefinery project, and their findings benefit projects across the industry. Since national laboratory projects can also be funded non-competitively through annual operating plans (AOPs), this gives BETO and the laboratories the ability to tailor projects based on new findings on a shorter time scale than issuing a new FOA would require.

DMT's work with the national laboratories has produced far-reaching benefits for the biofuels industry. DMT

recognizes the strength of the national laboratories and aims to continue utilizing them in future work. ORNL's Fire Standards Codes and Prevention in IBRs is a great example of a project outside of core technologies that has had a large impact industry-wide, and DMT will consider implementing similar projects in the future.

Recommendation 3: Develop FOAs that Use Existing Assets for Testing and Test for Longer Periods

While the Review Panel noted that DMT would require greater funding levels to grow its portfolio, they also recommended “capital-light” approaches that the program could incorporate in order to have a continued impact without relying on high levels of funding. The Panel recommended that DMT select projects that utilize existing assets to reduce the amount of resources spent developing a green field space. These projects can yield more rapid results by utilizing existing assets.

Additionally, the Panel recommended that the DMT Program extend its current goal of 1,000 hours of operation for a pilot-scale biorefinery. The Panel noted that as more companies tend to skip the demonstration-scale phase, they are losing important operational data that extended operations could provide. For example, PO-ET-DSM's pilot facility has been run for tens of thousands of hours and has provided critical data that can further inform commercial-scale operation.

DMT agrees that the data collected through pilot- and demonstration-scale operation of biorefineries is critical to identifying and mitigating issues that will arise at

commercial scale. As operation of these facilities can be expensive, some projects choose to abandon smaller-scale operations after 1,000 hours as a cost-saving measure, which may ultimately cost the project more in the long run. As mentioned previously, the PD2B3 FOA will hold a set amount of funding aside specifically for testing facility operation at pilot- and demonstration-scale biorefineries. This may help mitigate the issue of projects scaling up prematurely due to limited funds. The recent IBR Optimization FOA is also focused on enabling the reliable and continuous operation of biorefineries, which will ultimately help these projects run for extended periods and allow them to collect the data necessary to inform a successful scale-up. DMT agrees with the Panel's recommendation and will consider implementing it further in future work.

As mentioned in previous sections, BETO will consider the Panel's recommendations and incorporate them, as appropriate, in program elements and future funding opportunities. The DMT team will also coordinate with the Feedstock-Conversion Interface Consortium to assess the potential for implementing some of the Panel's recommendations for greater synergy among projects.

BETO, the DMT program manager, and the DMT technology managers would like to thank the Review Panel for their time and their engaged review of the BETO's DMT Program. The Panel's comments were largely positive and provided the program with the type of actionable feedback that can help promote progress towards the development of commercially viable bioenergy technologies.

FIRE STANDARDS CODES AND PREVENTION IN IBRS

(WBS #: 3.1.3.2)

Project Description

The project’s goal is to work with industry partners to develop and refine industry codes and standards to facilitate industry expansion while (1) protecting people and assets from fire and (2) expanding business opportunities by meeting sustainability expectations. Working with industry stakeholders in the Biomass Industry Panel on Codes and Standards, the project team conducted experiments to determine appropriate classifications for corn stover and switchgrass in the National Fire Protection Association Sprinkler Discharge Standard.

Future work is also underway to (1) develop a guideline document to explain relevant building and fire codes for engineers and code reviewers developing new

Recipient:	Oak Ridge National Laboratory
Principal Investigator:	Erin Webb
Project Dates:	10/1/2014–9/30/2017
Project Category:	Ongoing
Project Type:	AOP
Total DOE Funding:	\$1,220,000

biomass-handling facilities, and (2) design experiments to determine parameters for designing safer outdoor biomass storage facilities.

Responding to industry concerns that current sustainability standards do not provide adequate guidelines to support fair and consistent comparisons, the ORNL project team helped form a committee of industry stakeholders to develop the new ASTM International “Standard Practice for Assessment of Relative Sustainability.” Following unanimous approval of the new Standard Practice, work is underway with industry partners to deploy and test it.

Weighted Project Score: 7.9

Weighting: For ongoing projects, there is equal weighting across all four evaluation criteria: Approach, Relevance, Accomplishments and Progress, and Future Work.

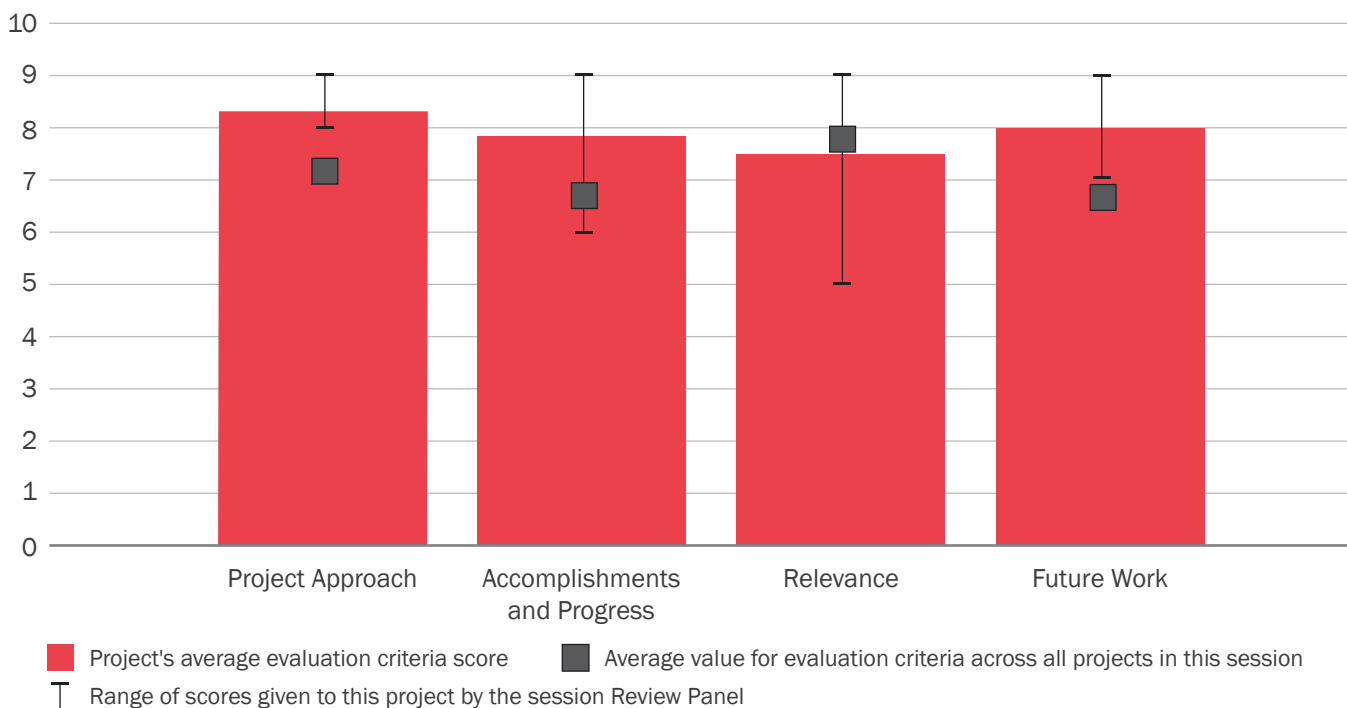



Overall Impressions

- My overall impression is that this has been a well-run project and is providing meaningful results. The only minor criticism is that the cost of planned work should have been estimated and built into their presentation, so we could see if they are on track to complete the project, but overall, this is well-done.
- The presentation overall was well-done. The topic is very useful to the industry to reduce risk and provide guidelines for storage of feedstock. More work on additional fire classification of feedstock would be useful overall. If possible, being able to model future feedstock storage guidelines based on the material heat of combustion, bale shape, density, and storage stack shape and size could be very useful for reducing fire risk for many industries utilizing biomass.
- This is an excellent project and represents important work to better understand biomass fire risk and develop best industry practices for biomass storage facilities. The project team did a great job leading and facilitating industry-backed committees to address scale-up barriers in the biomass supply industry. It would be nice to see further DOE-funded work to address fire ignition sources and how to prevent widespread dissemination of fires.
- This is a highly relevant project that can be streamlined to have a greater impact to the overall industry. Testing could be more focused and have a clearly quantified financial benefit/analysis tied to various scenarios. This would be helpful in allowing the industry to evaluate different options and would likely lead to a greater impact on the industry. The Biomass Industry Panel on Codes and Standards should be leveraged in deciding what future testing should be done and where the greatest need for additional codes is (various feedstocks, etc.).
- The standard development for fire prevention is a tangible and valuable asset for industry trying to utilize two of the top farm-based cellulosic feedstocks, switchgrass and corn stover. The results have been interesting to date and are already useful for planning layouts and providing additional direction to feedstock baling best practices and equipment design in the field.

Although it was a small part of the overall budget of this project, as written, the sustainability standard does not appear to address a gap or need to the industry. The specification does not appear to provide additional value over basic project management standards (e.g., identify stakeholders, have a communications plan).

The team is ahead of schedule and within budget. The team is executing the plan it set out to do and does not appear to have run into any technical or project management challenges. Overall, this is a good project that is being well-run.

- Overall, this work is to fill a very important gap in industry knowledge and allow industry participants to focus more on their core processes, rather than learning on the job. It was nice to see the approach of doing actual burn tests to generate real data on the matter.

PI Response to Reviewer Comments

- Tasks on ASTM International and fire codes are combined because (1) both tasks support market demonstration goals; (2) they address common BETO barriers (high risk of large capital investments; codes, standards, and approval for use; and lack of acceptance and awareness of biofuels as a viable alternative); and (3) the combination generates synergies and more-efficient management of scarce resources. Counterparts and researchers under each task have provided mutually beneficial information to the other task.

As recommended, the ASTM International task is being revised to respond to industry priorities and address the clear and present danger to U.S. trade

(\$3 billion/year in ethanol and pellets) created by a potential loss of market access due to non-tariff barriers in the form of sustainability standards. The ASTM task is founded on industry requests to fill gaps that address relevant trade barriers to biobased U.S. exports.

The next issue to be addressed is the definition of a counterfactual or “reference” case. Biased depiction of a reference case has been instrumental in justifying proposals in several European nations to ban U.S. wood pellets (\$1 billion per year of U.S. exports). We propose to continue collaborations with ASTM and industry to ensure that the investments made to develop ASTM E0366 achieve lasting and valuable impacts for the U.S. economy.

RENEWABLE ACID-HYDROLYSIS CONDENSATION HYDROTREATING (REACH) PILOT PLANT

(WBS #: 3.4.1.19)

Project Description

This project’s goals are to design, build, and operate a pilot plant to scale up the Mercurius REACH process. The REACH process is a novel technology that efficiently converts cellulosic biomass into drop-in hydrocarbon jet fuel and diesel. This process aims to provide an economically viable technology to start building cellulosic biofuel capacity for Renewable Fuel Standard mandates, as well as to compete with petroleum economics down to \$40/barrel of crude. The REACH technology is based on acid hydrolysis to non-sugar intermediates, such as chlormethylfurfural (converted to other compounds). The greatest technical and non-tech-

Recipient:	Mercurius Biofuels
Principal Investigator:	Karl Seck
Project Dates:	9/30/2013–12/31/2016
Project Category:	Ongoing
Project Type:	FY 2013—IBR iPilot: DE-FOA-0000739
Total DOE Funding:	\$4,684,619

nical challenges facing this project are acid recovery/re-cycle, product quality, techno-economic validation, and investment funds for further work and operations.

Overall Impressions

- Raising money is extremely difficult in the current environment. This project perhaps highlights a need for matching funds to be in place prior to award, or to be required within some set number of months of the award, prior to starting the project. The technology looks promising, but without the funds necessary to execute it, we may never know.

Weighted Project Score: 5.3

Weighting: For ongoing projects, there is equal weighting across all four evaluation criteria: Approach, Relevance, Accomplishments and Progress, and Future Work.

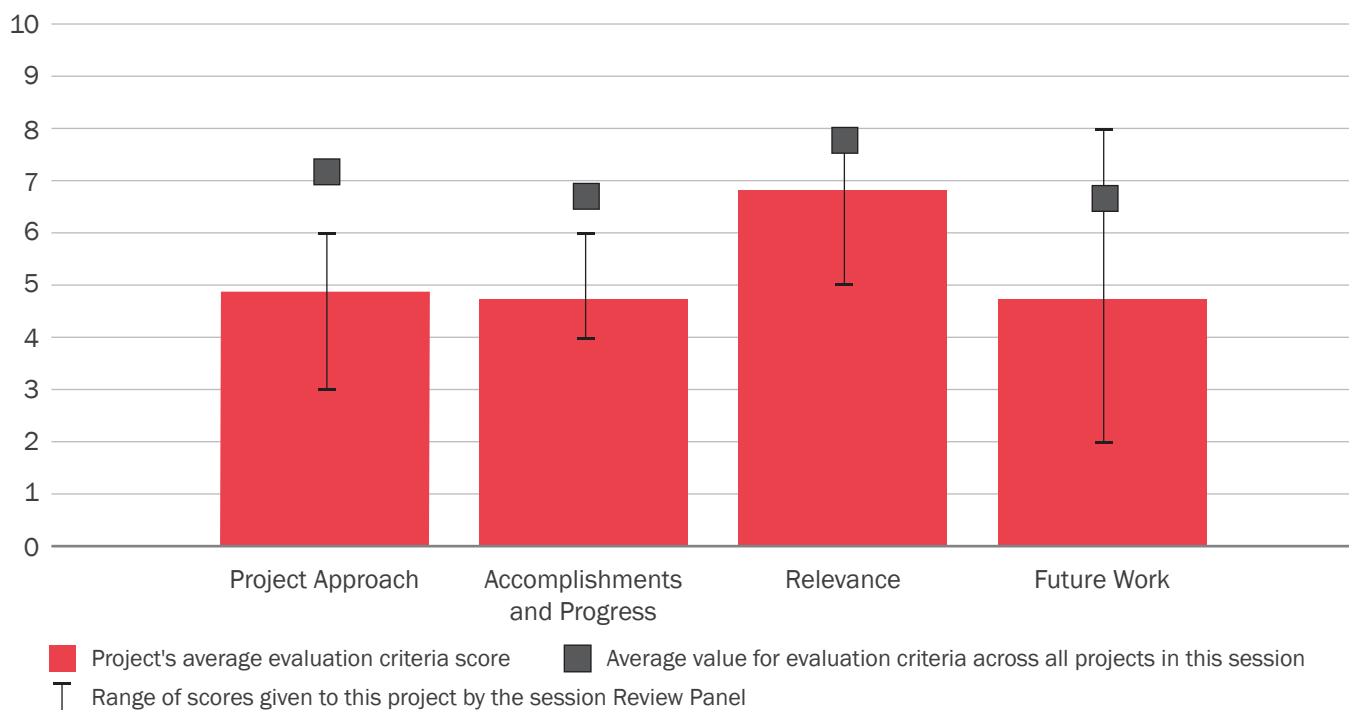

- The technology appears to be in the early phase of development, and the recipient may have been closer to bench/small process development unit scale rather than pilot scale when the grant was received. The presenter is optimistic about potential issues, beyond acid hydrolysis. It has yet to be seen whether this small business project team has the depth to meet the funding requirements for advancing to Budget Period 2 by the end of the no-cost extension. The cost metrics looked good, but it was unclear if the metrics had been refined with information gleaned over the course of the project.
- The project offers an innovative technology with the potential to be a game-changer for the cellulosic biofuel industry. More R&D work may be needed before the project is ready for a larger scale, particularly on the front end of the process. The project has had difficulty fundraising, and the future of the project is in jeopardy.
- This project is complicated and will require strong project management skills and discipline to be successfully executed. While the current approach may save immediate capital requirements, it does so by adding to the risk of cost overruns and schedule delays because it lacks an integrated bench-scale facility. The PI may want to consider partnering with a strong strategic investor to ensure the technology can be demonstrated successfully, or re-scope the project to something smaller and more focused. BETO should require that a binding recovery plan be agreed upon between the parties before continuing to fund this project.
- The project appears to be caught between a fundraising rock and a cost-of-engineering hard place. Like all projects in its portfolio, this project has technical risks, and DOE and BETO are right in holding firm to the contingency level required for this project.
- Overall, the REACH technology represents an innovative approach that has the potential to reduce

the capital costs of cellulosic fuels facilities. The project is certainly unique within DOE's conversion portfolios, and it is nice to see DOE support some of the out-of-the-box technologies. The project is currently behind schedule, and completing the project in a timely manner will be very difficult. Absent a very detailed plan/schedule on how the project is to complete its work, there is a risk that the Budget Period 2 funds could be exhausted without advancing the technology.

PI Response to Reviewer Comments

- Regarding the contingency requirement, it is Mercurius' view that the required contingency should be based on a risk assessment of the specific project and be a shared requirement per the cost share of the grant.
- Regarding the need for more R&D work, the acid-hydrolysis step of our process has been thoroughly investigated at a bench scale. Hundreds of runs have been made by multiple labs. It is our opinion that we have done sufficient R&D on the front-end process.
- General: Other comments seem to assume everything would be fine if we just made better plans or used better project management techniques. This might be a good answer on a test in business school, but it is not the answer to all problems in the real world. It is certainly not the solution to delays in this project. As commented in another section, the problem is funding and managing laboratory sub-recipients that have to supply dollar-for-dollar cost share. Project management techniques that are designed for capital projects and large, well-funded bench-scale investigations do not translate very well to the front end of our project.

All this being said, I realize that the reviewers are put in the difficult position of evaluating a complex project with only a little information (nothing proprietary) in a short period of time.

LIBERTY—LAUNCH OF AN INTEGRATED BIOREFINERY WITH ECO-SUSTAINABLE AND RENEWABLE TECHNOLOGIES IN YEAR 2009

(WBS #: 3.4.3.3)

Project Description

POET-DSM’s Launch of an Integrated Biorefinery with Eco-Sustainable and Renewable Technologies in Year 2009 (LIBERTY) is dedicated to the development and operation of a commercial-scale cellulosic ethanol biorefinery.

The plant is co-located with POET Biorefining – Emmetsburg, an existing corn-based ethanol biorefinery in Emmetsburg, Iowa. The corn-based biorefinery currently has a name-plate capacity of 50 million gallons/

Recipient:	POET-DSM
Principal Investigator:	Mike Dishman
Project Dates:	10/1/2008–12/31/2017
Project Category:	Ongoing
Project Type:	FY 2006—IBR Section 932 FOA: DE-PS36-06G096016
Total DOE Funding:	\$87,844,240

year and is one of 27 POET biorefineries. At full capacity, Project LIBERTY will produce an additional 25 million gallons/year of cellulosic ethanol from a feedstock of lignocellulosic material, i.e., corn cobs and high-cut material from the corn plant. Corn farmers from the surrounding area supply the feedstock to the biorefinery. The Project LIBERTY business model will enable rapid deployment of the cellulosic ethanol process across an expansive corn ethanol industry. The rollout of LIBERTY technologies will help the nation rapidly advance toward its biofuels mandates and reduce its dependence on foreign oil.

Weighted Project Score: 7.7

Weighting: For ongoing projects, there is equal weighting across all four evaluation criteria: Approach, Relevance, Accomplishments and Progress, and Future Work.

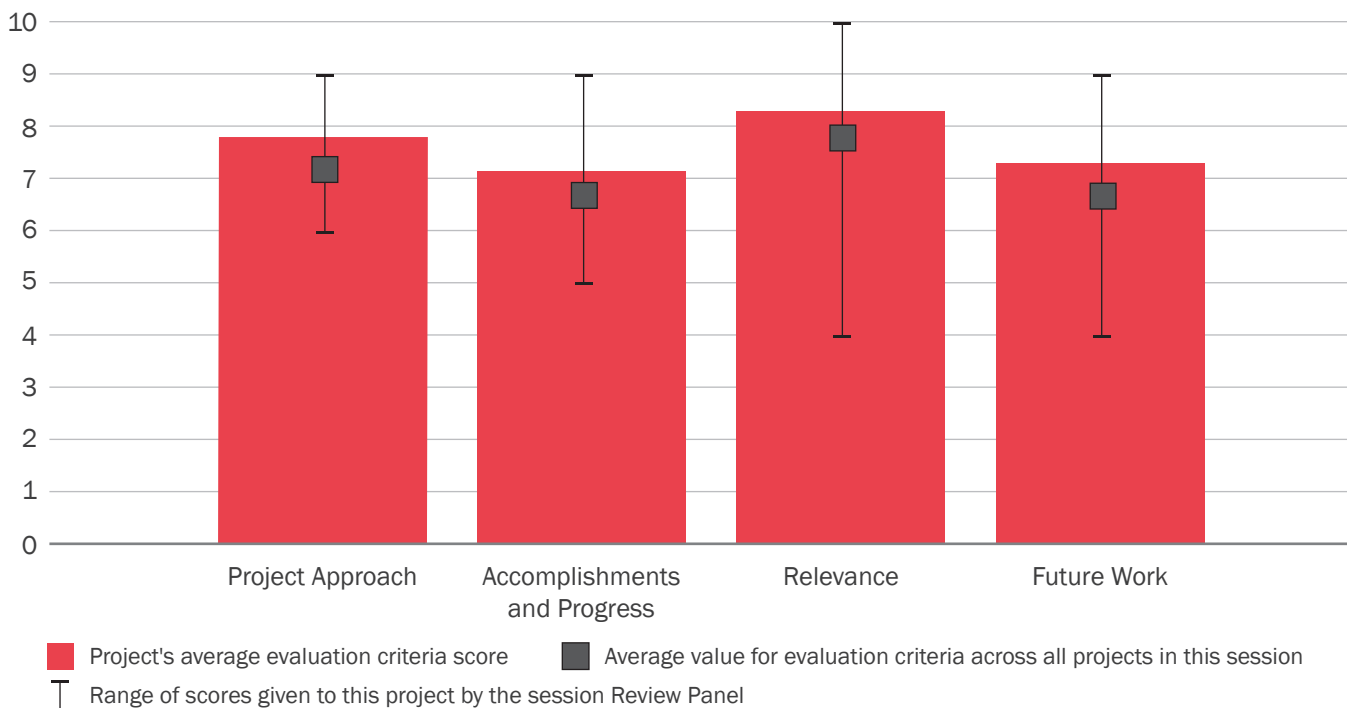



Overall Impressions

- Even at their goal of \$10/annual gallon, the future economics hinge on Renewable Identification Numbers. That seems like a shaky economic proposition at this point. Overall, though, the project has attained most of its goals and has been well-run. I hope they can soon solve their remaining technical challenges and reach sustained design output, and then get on with a second plant (and a third).
- Given the overall timeframe for the project and development along the way, this appears to be a well-run project. It would be of interest to have more information about the project's challenges as a lesson(s) to other projects to follow in order to promote the success of the biofuels industry overall.
- The success of this project is critical for advancing the state of the biofuel industry. I am optimistic that the project's start-up challenges will be resolved and that the plant will achieve design capacity.
- It is not clear that this is a financially viable project or one that could be duplicated. The project shared very little information on challenges it is encountering. The overall industry would benefit from lessons learned being shared, especially pertaining to equipment or processes that are common/not proprietary, driving down the costs for the industry

as a whole. The project based much of its operational plan on its experience at the pilot-plant level; however, comparisons of commercial-plant versus pilot-plant results were not shared. It would be useful to understand what, if any, benefit the project would have had in building a demonstration-scale plant and if the costs of doing so would be less than the costs being encountered to overcome some of the challenges in ramp up (this would be helpful for smaller companies in evaluating the benefits of building the demonstration-stage plant or not). Feedstock handling remains a major industry challenge (including to POET), and it would be useful if the project would share its lessons learned and collaborate with other companies to help overcome this common challenge. I believe the economic viability of POET's process would be realized through collaboration.

- POET-DSM's Project LIBERTY has successfully built a cellulosic ethanol facility using their technology. They have proven that their technology can produce ethanol from corn stover. However, they have not yet proven the availability of the system or the commercial viability of the technology. These are two key drivers of any future plant.

POET-DSM should be congratulated for continuing to persevere in the face of startup headwinds. We all hope they achieve commercial success.

Once POET-DSM achieves commercial operations, it will be a star project for DOE and BETO to point to in order to display the impact that they can have on pushing new technologies to commercial viability. The POET project would not have been successful if it were not for DOE's support.

- Overall, this is a very impressive project that was made possible with BETO support. As potentially the first large-scale commercial biorefinery to enter into normal production, this plant could open the

next chapter in the biorefining industry. Both BETO and POET should be proud of their accomplishments here; the number of jobs created in rural areas could be a game changer for the U.S. economy.

PI Response to Reviewer Comments

- POET-DSM believes our advances in the challenges to the cellulosic biofuel industry will propel the industry forward. We know our process works and believe the United States and the world will become invested as we continue to prove cellulosic biofuels are no longer a fantasy fuel.

BROOKHAVEN NATIONAL LABORATORY BIO-OIL DEPLOYMENT IN THE HOME HEATING MARKET

(WBS #: 5.3.0.1)

Project Description

The heating oil market represents a potential early market entry point for emerging, near-commercial, upgraded bio-oils. This project is focused on identifying commercial projects, which may provide fuels for this market and provide technical evaluation of the use of these fuels in heating oil blends. Distillate heating fuel is widely used, mostly in the Northeast. Non-transportation distillate use was 10.9 billion gallons in 2014.

This study has focused on displacing part of heating oils with upgraded pyrolysis oil. The quality of these fuels is affected by process conditions, and there is a

Recipient:	Brookhaven National Laboratory
Principal Investigator:	Thomas Butcher
Project Dates:	10/1/2013–4/30/2016
Project Category:	Sun-setting
Project Type:	AOP
Total DOE Funding:	\$1,150,000

cost/quality trade-off. Partially upgraded fuels may be the economical compromise—containing residual oxygenates but still providing good performance in use. The focus of this work has been on fuels that can be blended at a minimum of 20% and used without changes to equipment. We studied four different biofuels, from minimally upgraded to fully upgraded. We also conducted combustion testing in both a quartz chamber and a heating boiler. The lowest quality fuel was fired without blending. The combustion quality of all tested fuels was acceptable.

Weighted Project Score: 7.6

Weighting: Approach–25%; Relevance–25%; Accomplishments and Progress–50%.

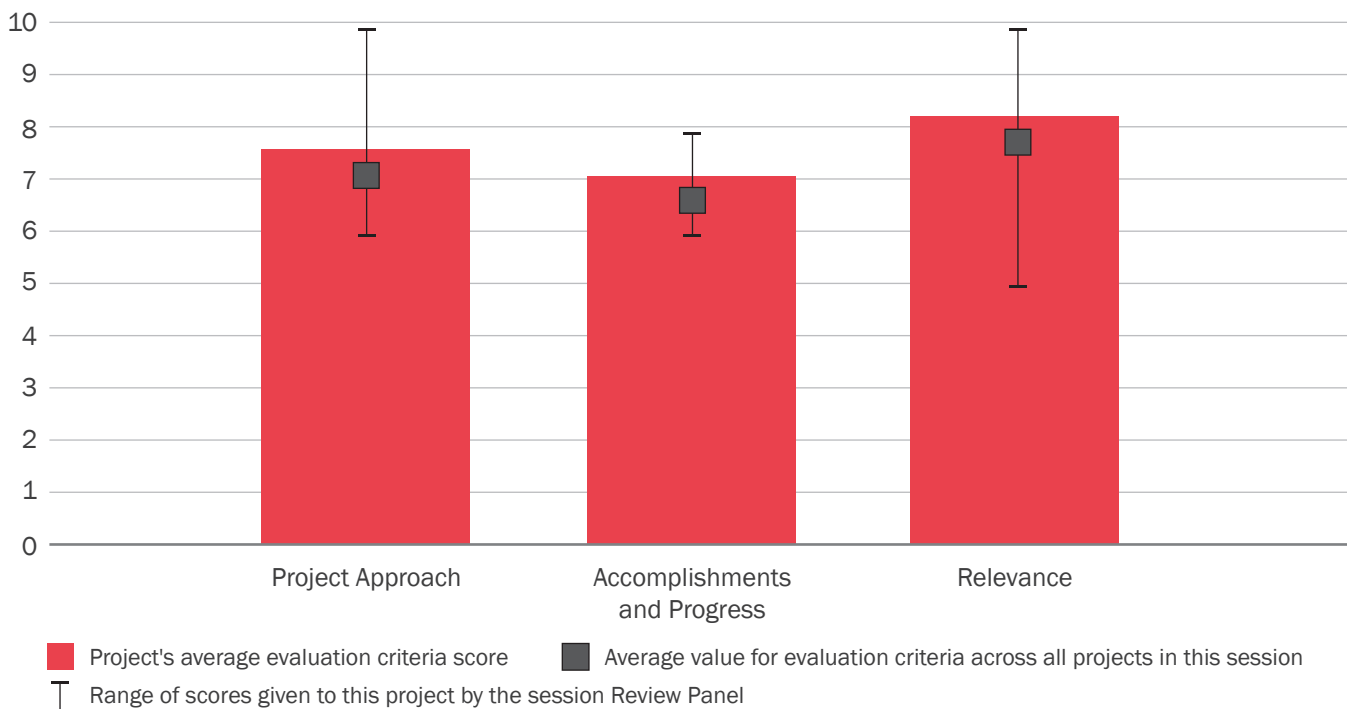

Research included compatibility of the test fuels with elastomers used in these applications. Elastomer swell was unacceptable with some fuels. Storage stability was also found to be poor except in fully upgraded fuels. We completed synthetic bio-oil blend studies in which specific oxygenates were added into petroleum fuel. The oxygenates were shown to increase elastomer as well. The addition of phenols increased the production of filterable insolubles in storage. A route to use of such bio-oils involves developing a storage stability performance-based specification. Overall, the study indicates strong potential for this fuel in this market.

Overall Impressions

- This was a good first step if the results, which seem preliminary, meet the stated goals. If the ASTM standards can be established, then the next obvious step is to look into economics, both from a supply and demand side. Producing pyrolysis heating oil to the ASTM design standards may be costly, so that needs to be investigated soon if this is to be a viable industry.
- The presentation and work were very well-presented. It is unfortunate that more samples were not provided for testing. However, the work provided a path for testing that must be considered for future biofuels that might be utilized for the home heating oil industry.
- This project has demonstrated technical feasibility of using renewable oil in the home heating oil market. Unfortunately, the scope of the project was modified as a result of bio-oil producers' reluctance of to supply fuel samples. Further work is needed in establishing/updating ASTM specification to give producers a target to achieve. There is an opportunity for BETO to support future work in this area, including testing of long-term storage stability and standards modification for this application. Focus should be made on ensuring fuel producers will be engaged in the project prior to award.

- This project could have significant impacts to the overall bio-industry (love the goals, etc.). However, the specifications and standards must be developed (meaning that more testing of actual available fuels needs to occur). It would be helpful to see what other arenas (besides the National Oilheat Research Alliance) could be taken to market the project to industry stakeholders. Besides standards, economic analysis for producers and consumers would provide something tangible in lieu of having an actual product for consumers and may provide more valuable feedback into where future work needs to occur.
- The project appears to be well-run despite having faced a severe hurdle in gaining interest from industry.

The project raised almost as many questions as it answered—which is good from a scientific perspective, but frustrating from a program development perspective. The results from this project appear to be a useful step in developing the renewable home heating oil market, but they are not sufficient to have completed the task of making this market viable. Further testing is needed to obtain ASTM certification for these fuels in this market.

The relevance of this market is larger than expected. The market for this project is almost as large as the corn ethanol industry's current output.

- This is a very interesting project, to open up a large and potentially easier market to enter. For future work within BETO, it may be helpful to identify where the test volumes are to come from at the beginning of the project so that resources can be added to generate test volumes if they are not available via the private sector.

PI Response to Reviewer Comments

- Establishing an ASTM spec for a low but not trace-level oxygen content bio-oil that is fully miscible with petroleum-based home heating oil is

a good next step, assuming the fuel producers want to introduce such a fuel into the market. The fuel producers should participate in this process, along with burner and component manufacturers, as part of ASTM because it will be an iterative process. If the route is taken to define such a new fuel, a next step will follow under which equipment manufacturers will need to develop and list new products compatible with this new fuel. A “limit” fuel will

need to be defined with more adverse properties than the specification fuel for the purpose of running the listing tests. This would include, for example, elevated total acid number to reflect the worst that would be expected in the field.

We fully agree that long-term storage stability testing needs to be part of future work, and a long-term storage stability specification needs to be included in the ASTM specification.

The background of the entire page is a blue-tinted image. The top half shows a close-up of water with many bubbles of various sizes. The bottom half shows a white tanker truck driving on a winding asphalt road that curves along a body of water. The landscape includes grassy hills and a cloudy sky.

CO-OPTIMIZATION OF FUELS AND ENGINES



TECHNOLOGY AREA

CONTENTS

INTRODUCTION	526
CO-OPTIMA OVERVIEW	526
CO-OPTIMA REVIEW PANEL	527
TECHNOLOGY AREA SCORE RESULTS.....	528
CO-OPTIMA REVIEW PANEL SUMMARY REPORT	529
CO-OPTIMA PROGRAMMATIC RESPONSE	531
CO-OPTIMA OVERVIEW.....	533
CO-OPTIMA HIGH PERFORMANCE FUELS OVERVIEW.....	537
CO-OPTIMA ANALYSIS OF SUSTAINABILITY, SCALE ECONOMICS, RISK, AND TRADE (ASSERT).....	542
CO-OPTIMA MARKET TRANSFORMATION.....	546

INTRODUCTION

The Co-Optimization of Fuels and Engines (Co-Optima) initiative is one of nine related technology areas that were reviewed during the 2017 Bioenergy Technologies Office (BETO or the Office) Project Peer Review. Co-Optima is new to the BETO portfolio as work under the initiative began after the last BETO Peer Review. While it is part of the Demonstration and Market Transformation (DMT) portfolio, Co-Optima was reviewed in a separate session due to its complexity and scale of work. In the Co-Optima session, six external experts from various related industries reviewed four presentations.

This review addressed a total U.S. Department of Energy (DOE) investment value of approximately \$50 million, with BETO contributing \$26 million and the Vehicle Technologies Office (VTO) contributing \$24,500 (fiscal year [FY] 2015–FY 2017 spending). The funding for the initiative’s six technical teams is split between BETO and VTO, with BETO primarily funding the Market Transformation (MT); Analysis of Sustainability, Scale Economics, Risk, and Trade (ASSERT); and High-Performance Fuels (HPF) teams. BETO’s portion represents approximately 3.7% of BETO’s portfolio reviewed during the 2017 Peer Review. During the review,

a principal investigator (PI) for each BETO-funded technical team and the overall PI of the nine-laboratory consortium project were given between 15 to 60 minutes to deliver a presentation and respond to questions from the Review Panel. Co-Optima was also reviewed at the 2017 VTO Annual Merit Review.³⁵ That review evaluated the progress of the technical teams primarily funded by VTO: Advanced Engine Development, Fuel Properties, and Simulation Toolkit.

The Review Panel evaluated and scored projects based on their project approach, technical progress and accomplishments from FY 2015 to FY 2017), relevance to BETO goals, and future plans. This section of the report contains the results of the project review, including full scoring information for each project, summary comments from each reviewer, and any public response provided by the PI. Overview information on the Co-Optima initiative, full scoring results and analysis, the Review Panel’s summary report, and BETO’s programmatic response are also included in this section.

BETO designated Alicia Lindauer as the Co-Optima Technology Area Review Lead. In this capacity, Ms. Lindauer was responsible for all aspects of review planning and implementation.

CO-OPTIMA OVERVIEW

The Co-Optima initiative aims to simultaneously transform transportation fuels and vehicles in order to maximize performance and energy efficiency, minimize environmental impact, and accelerate widespread adoption of innovative combustion strategies. This research and development (R&D) collaboration between VTO, BETO, nine national laboratories, and industry is a first-of-its-kind effort to combine biofuels and combustion R&D, building on decades of advances in fuels and engines.

The Co-Optima initiative takes a three-pronged, integrated approach to identifying and developing the following:

- Engines designed to run more efficiently on affordable, scalable, and sustainable fuels
- Fuels designed to work in high-efficiency, low-emissions engines
- Marketplace strategies that can shape the success of new fuels and vehicle technologies with industry and consumers.

³⁵ Learn more on the VTO Annual Merit Review and Peer Evaluation web page: <https://energy.gov/eere/vehicles/annual-merit-review-and-peer-evaluation>

Co-Optima Support of Office Strategic Goals

Co-Optima's main goal is to identify the combinations of fuel properties and engine characteristics that maximize efficiency, independent of fuel composition or production pathway, to allow the market to define the best way to blend and provide these fuels. We are pursuing a systematic study of fuel blendstocks (represented as classes of molecular families) to identify a broad range of feasible options. The objectives are to identify blendstocks that can provide target ranges of key fuel properties, identify trade-offs on a consistent and comprehensive basis, and share information with stakeholders.

Co-Optima Support of Office Performance Goals

Co-Optima activities support Office goals by developing the knowledge, data, and tools to expand the blendstock options available to achieve desirable fuel properties.

Co-Optima seeks to identify technology options for commercial liquid fuels and high-performance engines powering the entire on-road vehicle fleet (i.e., passenger to light truck to heavy-duty commercial vehicles, including hybrid electric vehicle architectures). The aggressive research timeline is structured around validating fuel and engine technologies to the point that industry can initiate product development with confidence, setting the stage for commercial introduction of new fuels and engines in the 2025–2030 timeframe. This will provide an opportunity to create market demand for up to 25 billion gallons of advanced bio-derived blendstock, diversifying our resource base and providing valuable flexibility to refiners to respond to significant evolving global trends in transportation fuel demand.

CO-OPTIMA REVIEW PANEL

The following external experts served as reviewers for the Co-Optima Technology Area session during the 2017 Project Peer Review.

Name	Affiliation
F. Michael McCurdy*	Leidos
Andrea Slayton	Slayton Consultants
Brandon Emme	ICM Inc.
Troy Hawkins	Eastern Research Group Inc.
Phil Marrone	Leidos
Candace Wheeler	General Motors (Retired)

*Lead Reviewer

TECHNOLOGY AREA SCORE RESULTS

Average Weighted Scores by Project

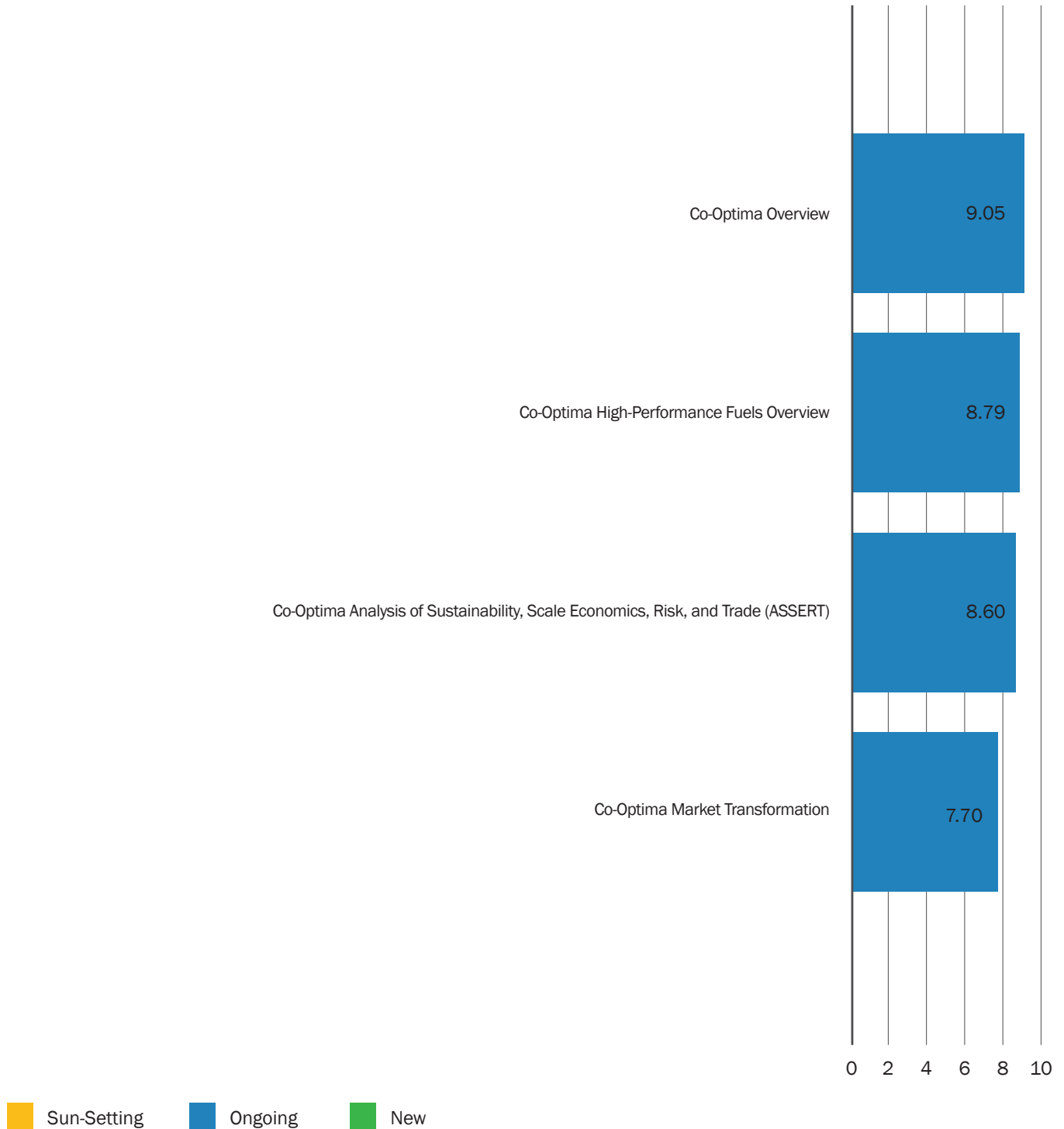

CO-OPTIMA REVIEW PANEL SUMMARY REPORT

Prepared by the Co-Optima Review Panel

Overview

The Co-Optima team will enable substantial transportation efficiency improvements by optimizing future engine and fuel designs contemporaneously. Custom fuels will be derived from biological sources while the future engine designs will move past traditional spark-ignition engines into higher-efficiency designs, which will have light- and heavy-duty vehicle applications. Key barriers to the adoption of the co-optimized fuel and engine technologies include such items as (1) qualification of the fuels for use on the road, (2) legacy spark engines and proving value of the new fuels, and (3) catalyzing engine development spending without the fueling infrastructure in place.

On behalf of the Peer Reviewers, we would like to thank the DOE Co-Optima team for the invitation to review the presentations and the presenters who took the time out of their busy schedules to summarize their projects to the public at large

Impact

The potential impact of the Co-Optima initiative is immense. The “chicken and egg” problem is real, whereby the design and deployment of advanced engines is contingent upon the availability of high-performance fuels while the commercialization of high-performance biofuels has been stalled waiting for a market for the fuels to develop. We see the government’s focus in this area as particularly important as a linkage between two different private-sector spaces (i.e., transportation and fuels). While the private sector is willing to invest R&D and development dollars within its core competencies, the sector has been unwilling or unable to invest on a cross-sector basis. By linking these two sectors through

the investments by BETO and VTO, DOE has the potential to be the catalyst that enables private investment for the better public good.

All members of the Peer Review Panel could see the potential value in the work, particularly in the (1) potential for customization of future fuels for performance, price, sustainability, or even for specific types of cars or engines; (2) performance benefits to the legacy fleet of engines and future engine designs that are not practical with the current fuel pool; and (3) access to new biofuel markets that would reduce carbon emissions and bring jobs and investment to rural America. Building the fuel properties database and modeling/simulation tools has the potential to drive near-term benefits as the information is transferred to those entrepreneurial companies who can bring the new engine and fuel products to market.

Innovation

The Co-Optima initiative is very innovative, pushing the limits of engine performance and new advanced biofuel production technologies simultaneously. This will benefit the automotive and biofuel industries, the environment, and consumers while promoting rural area jobs and investment. The collaborative approach undertaken by the national laboratories is very innovative, incorporating a selection process that will deliver results in the near- to medium-term, particularly in “Thrust I,” the spark engine fleet. Evaluation and selection of blendstocks based on their economic and environmental benefits should allow BETO/VTO to direct resources into delivering both near- and long-term benefits for the American consumer.

While it would certainly be a stretch goal for the initiative, the Peer Review Panel members noted the potential for new and innovative processes for the qualification of fuels and engines that may be possible with the coordinated efforts of BETO/VTO, the U.S. Environmental Protection Agency, and the private sector.

Synergies

The synergies within BETO/VTO programs are numerous, most notably that higher-oxygen biofuel components represent an unexplored category of chemicals for the transportation sector with the potential to dramatically increase the efficiency of existing spark engines and could enable advanced engine designs with substantial performance and efficiency gains. The Panel saw the initiative as a very natural extension of the DOE's core competencies and that public investment in this underfunded linkage has spillover benefits to the transportation and biofuel sectors, with synergies across the entire fuel-based transportation sector.

The Panel saw opportunities for better integration of the DMT and Conversion R&D Programs with Co-Optima as the generation of fuels for testing has been a rate limiting step for Co-Optima and appears to be outside of the core mission of the Co-Optima initiative. By utilizing fuels produced at various private- and government-supported pilot and demonstration-scale facilities rather than producing the fuels internally within the national laboratories, the initiative would focus more keenly on the most promising technologies in the near term while informally pairing the new fuels and engine designs improving the speed to market. It was the opinion of the Panel that the production of the fuels for testing may be better located within the Conversion R&D Technology Areas (i.e., Thermochemical, Biochemical, and Waste to Energy) so that the funds could be used to advance the maturity of the technologies. Reducing expenses associated with fuel generation may also free up resources for more engine or combustion testing.

Focus

The Co-Optima area appears poised to generate a wealth of new data from which new fuels and engines can be designed and optimized. The focus on options analysis to down-select from the large pool of more than 300 Tier 1 potential technologies to the much smaller and

focused pool of 40 Tier 3 technologies was very impressive to the Panel. There is a dizzying array of potential technologies available and the rigorous, property-based screening approach will be needed to ensure that the work stays on track.

The Panel would have liked to see more emphasis and strategic planning in the MT area as the handoff from the Co-Optima initiative to the private sector for execution and deployment is where U.S. taxpayers will see a return on their investment. While the Co-Optima team has identified the need for a handoff, the stakeholders that are to receive the data are not well-defined as of yet. Better definition of who may be receiving the information and how they will use it to catalyze deployment of the engine or fuel technologies will reduce the risk that the data are not used in a beneficial way for the public. The Panel and some public attendees noted that the qualification of new fuels and engines is not a trivial task, and that some attention to how the new technologies get qualified would be beneficial to the initiative.

Commercialization

Co-Optima appears to be at the optimal stage in the development pipeline in that it pairs fuels and engine technologies in similar development stages so that they may mature in their development together. Engine designers can focus on the properties of fuels that are likely to be available, while fuel producers can tailor their output to the markets that are likely to be available. With each side focusing on the best available technologies, this could speed up the technology deployment timeline. This focus on fuels and properties also provides an opportunity to identify regulatory issues early in the commercialization process so that they can be addressed during the maturation of the technology rather than when an engine/fuel solution is technically ready to go to market.

The Panel remarked how an early adopter test case using public transportation or school could be beneficial to Co-Optima in that it could provide some definition for

the rollout strategy under development by the MT team. The rollout strategy will be key to managing expectations and keeping the various initiative stakeholders on board as the work progresses.

Recommendations

Based on the Peer Review and the Panel's experience, our top three recommendations to the Co-Optima Team are as follows (in no particular order):

- **Develop a Risk Matrix for Thrust I Market Transformation:** Given the primary goal of deploying new engine and biofuel technologies for the benefit of consumers, the environment, and for rural jobs, it was our opinion that the Co-Optima initiative could benefit from producing a matrix of the adoption risks and then adjusting the near-term work to mitigate those risks. Whether the risks are in the technologies, regulatory issues, consumer value proposition, stakeholder fatigue, or other unidentified item, analyzing the project design against a deployment goal could be beneficial in prioritizing project workflow for the maximum benefit.

- **Source Candidate Materials from BETO's Conversion R&D and DMT Programs:** The goal of the Co-Optima initiative is the co-optimization of fuels and engines, not the development of new fuel production pathways. By sourcing material from the Conversion and DMT teams, the initiative could free up substantial resources which could be redirected into strengthening the combustion dataset and MT efforts. As a side benefit, private fuel producers may be willing to share more data for ASSERT and other models if Co-Optima is not viewed as a potential competitor.
- **Add Regulatory Issues to the ASSERT Models:** The ASSERT models appear to address the environmental and economic issues quite well, and the addition of a regulatory block within the models could make them much more robust in reflecting real world adoption of the various candidate molecules. Private-sector analysts look at regulatory items as part of a three-legged stool of environmental, economic, and regulatory issues.

CO-OPTIMA PROGRAMMATIC RESPONSE

BETO sincerely thanks the Peer Review Panel for its time, active engagement, and constructive review of the Co-Optima initiative portfolio. In putting together the Co-Optima Peer Review Panel, it was our hope to welcome a wide range of perspectives, and thus we invited reviewers from the DMT, Analysis and Sustainability, and Conversion Technology Area Review Panels. The value of these diverse Panel members' feedback was clear in the thorough and insightful comments and recommendations that were received. The Peer Review Panel's praise of the potential value and impact of the work undertaken by the initiative is much appreciated,

as well as the recognition of the spillover benefits to the transportation and biofuels sectors. The Peer Review Panel's recommendations will be used to further enhance the effectiveness of the Co-Optima activities and contribution to the Office's goals.

Reviewers provided feedback on the three BETO-funded Co-Optima technical teams' activities. The Co-Optima leadership team is working with PIs to address this feedback to strengthen their future work plans. The reviewers also provided feedback to the overall Co-Optima initiative, which was organized into three general recommendations. We greatly appreciate these recommendations and are already working to incorporate these suggestions into priorities for FY 2018 and beyond.

Recommendation 1: Develop a Risk Matrix for Thrust I Market Transformation

BETO agrees that the development of a risk matrix would be a beneficial addition to the market transformation activities within Co-Optima and will work with the team to ensure that this is addressed in FY 2018.

BETO also agrees with the reviewers' comments that a clear vision and strategy is needed for MT activities under Co-Optima. We are working with the national laboratory team to develop a program-level vision for market transformation that establishes a clear strategy around industry handoffs and fits under the current Administration's priorities. In developing this strategy, we will draw on the input that has been received at the stakeholder listening days and during one-on-one visits with targeted stakeholders and will continue to work closely with the consortium's external advisory board.

Recommendation 2: Source Candidate Materials from BETO Conversion R&D and DMT Programs

BETO appreciates this recommendation and the Review Panel's suggestion to look for opportunities for better integration with BETO's DMT and Conversion R&D Programs. While we have made an effort to coordinate with BETO's Conversion R&D Program during the planning and execution phases of Co-Optima in order to understand linkages and ensure that there is no duplication across the technology area portfolios, we recognize that there are opportunities to strengthen this coordination and will continue to do so. In 2018, we will work to

strengthen this coordination at the BETO staff level and among the national laboratory PIs.

Under the Co-Optima initiative, BETO works to identify and evaluate performance-advantaged biobased fuel components with desirable properties to accelerate the introduction of affordable, scalable, and sustainable high-performance fuels for use in high-efficiency, low-emission engines. While Co-Optima does not have a specific goal around development of new fuel pathways, BETO feels that some work on fuel development is appropriate and necessary to support the initiative's goals. That said, when sourcing candidate materials, fuel blendstocks will be obtained from commercial sources and surrogates will be used when possible to effectively reduce costs. When commercial sourcing is not possible, we will look for opportunities to source materials from Conversion and DMT projects.

Recommendation 3: Add Regulatory Issues to the ASSERT Models

BETO thanks the reviewers for recognizing the ASSERT team's capabilities in addressing environmental and economic issues and appreciates the recommendation to strengthen the capabilities around addressing regulatory barriers. At present, policy and regulatory variables in two models used by the ASSERT team, the Biomass Scenario Model and Automotive Deployment Options Projection Tool, implicitly address regulatory issues. Although there are no current plans to develop new models, Co-Optima is considering restructuring the portfolio so that market transformation analyses, which address regulatory barriers, are integrated under the ASSERT team.

CO-OPTIMA OVERVIEW

Project Description

The Co-Optima initiative is a DOE effort funded by BETO and VTO to identify the fuel properties and engine-design characteristics needed to maximize vehicle performance and affordability, while deeply cutting harmful vehicle emissions. The overall goal of the effort is to achieve a 25%–30% reduction in per-vehicle petroleum use by 2030 by enabling higher efficiency engines powered by fuels containing bio-blendstocks that are sustainable, affordable, scalable, and compatible with infrastructure. Multiple research efforts on spark-ignition and compression-ignition strategies are underway with the goal of identifying solutions applicable across the light-, medium-, and heavy-duty vehicle sectors. The fuel property focus of the R&D includes efforts directed toward characterizing and exploiting the unique properties available from biomass-based fuel blendstocks.

Recipient:	National Renewable Energy Laboratory, Argonne National Laboratory, Idaho National Laboratory, Los Alamos National Laboratory, Lawrence Berkeley National Laboratory, Oak Ridge National Laboratory, Pacific Northwest National Laboratory, Sandia National Laboratories
Presenter:	John Farrell
Project Dates:	10/1/2015–9/30/2018
Project Category:	Ongoing
Project Type:	Annual Operating Plan
DOE Funding FY 2014:	\$0
DOE Funding FY 2015:	\$0
DOE Funding FY 2016:	\$26,000,000
DOE Funding FY 2017:	\$24,500,000

Overall Impressions

- This is a very exciting initiative with a good marriage between the chemistry of potential blendstocks

Weighted Project Score: 9.1

Weighting: For ongoing projects, there is equal weighting across all four evaluation criteria: Approach, Relevance, Accomplishments and Progress, and Future Work.

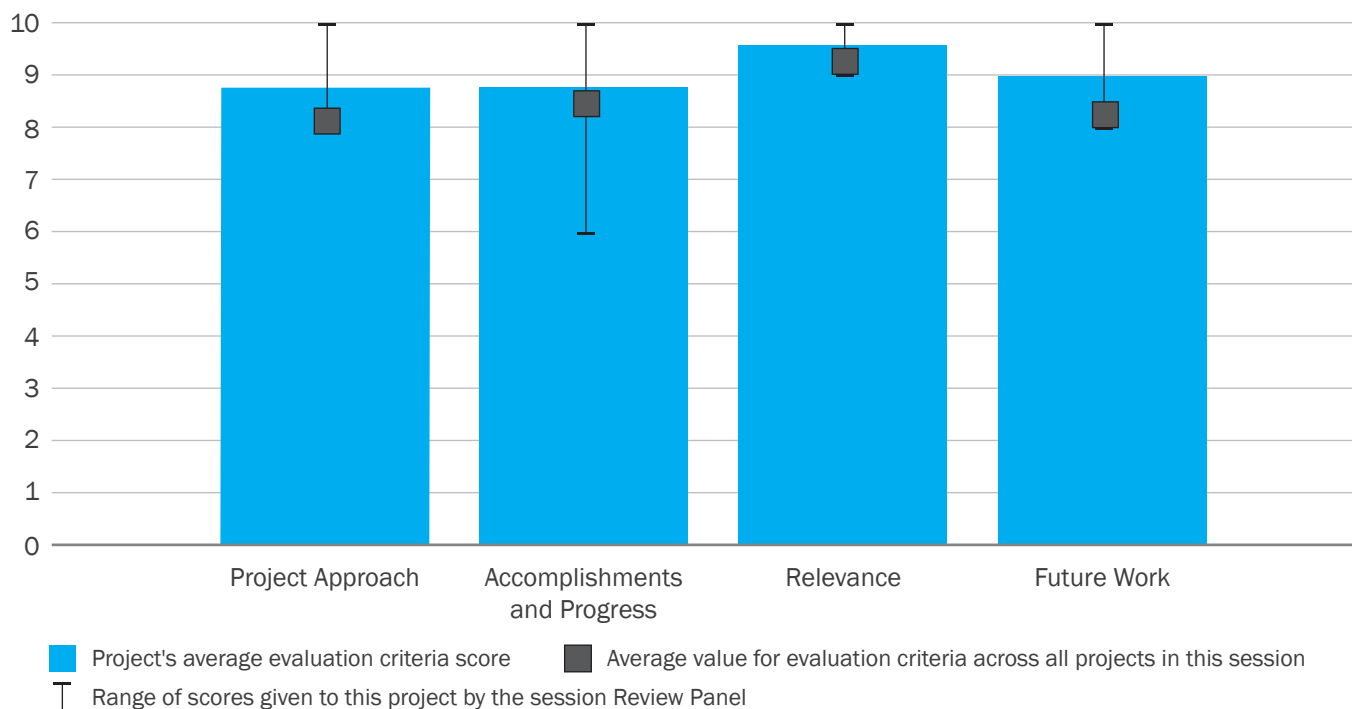

for biofuels (and potentially petroleum-based fuel) and engine efficiency. Funding has the potential to affect several industry players rather than promote one company as with other projects. The focus on developing fuel blends specific to increased engine efficiency development takes it one step further (i.e., Thrust II). With the practical modeling of economic, environmental, and market metrics for each candidate, this initiative helps industry as a whole evaluate the potential blendstocks. The initiative appears to be very well-organized and managed. The missing links and apparently by design, are how to implement change and provide industry incentives to use the valuable information and tools that will be available for the BETO goals.

- Ideally, this work provides a better fuel quality metric for consumers than the octane rating used today. The team may want to consider how to best drive toward true “pay for performance” in our liquid fuels.

The team understands that hybrid vehicles, et al., create some additional layers of complexity to co-optimization and that ultimately the link to the drive train is what matters (i.e., a Co-Optima co-optimization). I would like to see some clarity how these factors impact the potential outcome of the initiative’s work with regard to having the greatest impact on the overall vehicle population/usage.

The industry practice of thrifting could have a market impact on realizing the environmental goals of the initiative.

- Co-Optima is an exciting new initiative that seeks to accelerate the introduction of affordable, scalable, and sustainable fuels that simultaneously take advantage of engine technology to gain efficiency and maximize vehicle performance. While a huge undertaking, this is an extremely valuable effort which could lead to radical changes in the energy and transportation sectors. It is great to see the collabo-

ration between BETO and VTO as well as the nine different national laboratories and other university partners that are working on the initiative.

For an effort of this size and complexity it is not surprising to have a full-time project manager to ensure the direction and milestones of the work are met. The initiative appears to be well-managed with regular updates, conference calls, and milestones. Communication across working groups will be essential. Using a consortium approach is key in utilizing the expertise and skill sets of the various groups within the national laboratories. Also, it is critical to the success of the program to maintain close ties with the external advisory board and outside stakeholders.

A great deal has been accomplished in the short time the initiative has been going. The specific accomplishments of the individual teams will be address in the following reviews. However, overall, balancing the shorter-term work on Thrust I designed to improve near-term efficiency of spark-ignition engines with the longer-term work to identify fuel properties that enable advanced compression-ignition engines will be critical. Both are important, and while the majority of the vehicles on the road are spark-ignition engines, the advanced compression-ignition work has the opportunity to spill over into the medium- and heavy-duty fleets. It will be interesting to see if this initiative can identify and exploit the unique properties found in biomass-derived molecules that are not available in petroleum-based fuels.

The work appears to be tightly linked with results from one group feeding into the work of another. This type of co-development and collaboration is critical when working on the fuel and engine sides. If successful, this initiative would enable the development of new fuels specifically designed to significantly improve fuel economy and vehicle efficiency. This would reduce fuel use and vehicle emissions, while increasing energy security and rural devel-

opment. The mission is clear and the stakes high. However, it is no easy task. Overall, it is a great initiative with potential wins for the bioeconomy, automotive manufacturers, and the environment. Two of the greatest challenges will be in building out the infrastructure and navigating the regulatory process to get these fuels certified for use. Therefore, initial focus should be on blendstocks that could have high impact. This also requires addressing the question of whether the fuel will be used in new cars only versus the legacy fleet. Having the U.S. Environmental Protection Agency and the California Air Resources Board on the advisory board may help get at the question of how we get the fuel certified for deployment in the marketplace.

In general, future work includes completing Thrust I and then shifting resources for a greater focus on Thrust II. Work will continue to focus on engine architectures and strategies that provide higher thermodynamic efficiencies and new fuels which are required to maximize efficiency and operability. This amounts to simultaneously identifying fuel properties that maximize engine performance while identifying blendstock options that provide key engine efficiency properties.

- Overall, it is certainly a very impressive initiative with a large number of contributors with vast expertise. The analysis of 400+ chemicals and down-selection to 40 represents a lot of good work that has been accomplished to date. The co-optimizer tool represents a vast opportunity where end users could customize their fuel products, potentially creating a market pull for these co-optimized fuels that would increase market uptake. My only concern with the initiative is that unless it includes qualification of at least a limited number of fuels, the regulatory hurdles could be a fatal flaw that severely limits the utility of the work performed.
- This initiative, which attempts to improve vehicle efficiency and reduce fuel consumption through a

fundamental rethinking of fuel choice and engine design, is essential and a showcase for what the national laboratories do best. This team provides value to industry by performing a thorough review of all possible fuel compounds derived from biomass and systematically examining each one to determine which will perform best. While this approach is critical to finding new breakthroughs, private industry would (unfortunately) never allocate the time or funding to do this type of work. One concern with all of this work is how it can be transitioned to and accepted by the fuel distribution industry, which may see no value to them in changing fuel blends and reducing/replacing the fossil fuel contribution and/or infrastructure.

PI Response to Reviewer Comments

- We thank DOE and the reviewers for organizing and executing the Peer Review. We appreciate the actionable feedback which we are acting upon to further improve the impact of the Co-Optima initiative.

We will share the positive comments with our researchers. Such comments help all of us understand the importance of what we do each day:

- “This is a very exciting initiative with a good marriage between the chemistry of potential blendstocks for biofuels (and potentially petroleum-based fuel) and engine efficiency.”
- “[T]his work provides a better fuel-quality metric for consumers than the octane rating used today.”
- “While a huge undertaking, this is an extremely valuable effort which could lead to radical changes in the energy and transportation sectors.”
- “A great deal has been accomplished in the short time the initiative has been going.”

The reviewers also provide important guidance. For example, “The mission is clear and the stakes

high. However, it is no easy task.” It is indeed not an easy task, and some of the challenges, also noted by the Peer Review Panel, include how we transition the work to industry. “The missing links and apparently by design, are how to implement change and provide industry incentives to use the valuable information and tools that will be available for the BETO goals.” At the same time, the Review Panel provides the means for us to overcome the challenge by staying close to vital stakeholders and how Co-Optima’s impact can be strengthened by external advisory board guidance, “[I]t is critical to the success of the initiative to maintain close ties with the external advisory board and outside stakeholders.” The Co-Optima leadership team works with our government sponsors to clearly define the roles of the laboratories, DOE, and industry. We work closely on linkages with leading stakeholders, including original equipment manufacturers, energy/biofuel providers, and regulators. All of this interaction with various stakeholders helps ensure that our scientific output addresses industry needs within market drivers and thus can lead to better fuels and engines.

The Review Panel also notes that we need to balance our shorter- and longer-term work to address transportation needs across the transportation sector. “[B]alancing the shorter-term work on Thrust I designed to improve near-term efficiency of spark-ignition engines with the longer-term work

to identify fuel properties that enable advanced compression-ignition engines will be critical.” We agree. In fact, we are updating goals around light- and medium-/heavy-duty ground transportation, and plan our work around meeting the needs of a wide range of vehicle types.

We also appreciate the Review Panel encouraging us to clean up our messaging even as we plan around macrotrends within the transportation sector. “The team understands that hybrid vehicles, et al, create some additional layers of complexity to the co-optimization and that ultimately the link to the drive train is what matters (i.e., a Co-Optima co-optimization). I would like to see some clarity on how these factors impact the potential outcome of the project work with regard to having the greatest impact on the overall vehicle population/usage.” As a leadership team, we will continue to focus our research on the emerging needs of the transportation industry and hone the clarity in our communication of the corresponding goals.

We thank the Review Panel again for great discussion and important, insightful, and actionable suggestions. We close with this quote from the Peer Review Panel: “This initiative, which attempts to improve vehicle efficiency and reduce fuel consumption through a fundamental rethinking of fuel choice and engine design, is essential and a showcase for what the national laboratories do best.”

CO-OPTIMA HIGH PERFORMANCE FUELS OVERVIEW

Project Description

The HPF team identifies new biomass-derived fuel options for more efficient engines with lower harmful emissions for Co-Optima. This is accomplished via a fuel property-based approach to developing biomass conversion-fuel chemistry-engine performance relationships. This approach leverages and complements the Conversion R&D program area while identifying materials with the right fuel properties and working backward to identify conversion pathways from biomass. The HPF team integrates the capabilities of seven national laboratories to identify new bio-blendstocks, assess their fuel properties, and establish conversion pathways for promising materials. Among other significant technical accomplishments, the team has identified 40 high-octane molecules and mixtures for spark-ignition engines, all of which meet a rigorous set of fuel

Recipient:	Pacific Northwest National Laboratory, Argonne National Laboratory, Idaho National Laboratory, Los Alamos National Laboratory, Lawrence Berkeley National Laboratory, Oak Ridge National Laboratory, Sandia National Laboratories
Presenter:	Dan Gaspar
Project Dates:	6/1/2015–9/30/2018
Project Category:	Ongoing
Project Type:	Annual Operating Plan
DOE Funding FY 2014:	\$0
DOE Funding FY 2015:	\$0
DOE Funding FY 2016:	\$9,510,000
DOE Funding FY 2017:	\$7,147,000

property criteria and provide key conversion pathway and fuel property data to other Co-Optima teams. The new materials span a wide range of functional groups, including hydrocarbons and oxygenates, and can be generated using biochemical, thermochemical, and

Weighted Project Score: 8.8

Weighting: For ongoing projects, there is equal weighting across all four evaluation criteria: Approach, Relevance, Accomplishments and Progress, and Future Work.

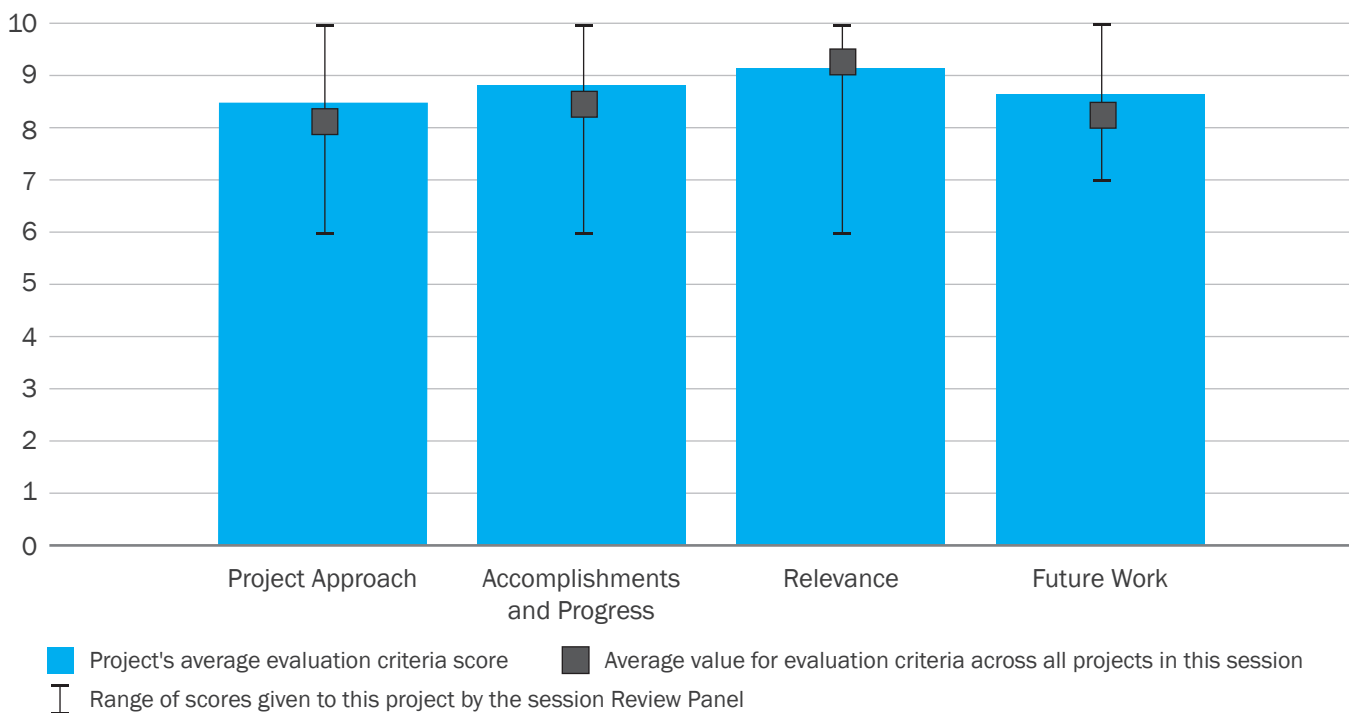

hybrid methods. A similar effort is underway for compression-ignition engines. The HPF team output also helps answer key questions in technical analysis. Thus, the HPF team's efforts are directly relevant to BETO goals to improve the value proposition for biofuels and develop new markets for biofuels.

Overall Impressions

- Overall the project approach is very exciting and a good combination of industry stakeholder interaction, and DOE/national laboratory skill sets. The work appears to be one that is common sense to do and hopefully industry will eventually run with some of the information provided. It appears that the work is well-managed on every front with good management and technical approach along with good communication and collaboration. The technical analysis thus far is very impressive, especially the winnowing of chemical characteristics from 400, to 20, to 4–5 chemicals in a relatively short period. Presenter Dan Gaspar did an excellent job presenting the HPF testing work. It was clear by the additional technical accomplishments in the supplementary slides that more time could have been spent on this topic.
- I suggest considering holding the PI annual kickoff before the budget year starts to maximize resource allocation efficiency.

A lot of great work and progress in identifying and sourcing a large group of candidates, with a lot more to find. It will be good to see more integration with VTO to see where the work is going to quantify the potential gains on a few examples. I like the practice of ensuring backwards compatibility and stability/corrosivity of lead candidates.

I suggest establishing or communicating how the blends the team has looked at so far demonstrate how suboptimal the current engines are in order to validate the assumptions about efficiency gains up to 30%.

As the presenters commented, the merit function used for much of the development is currently best available but not perfect and is undergoing some improvements. It would be interesting to know if this can be used to benchmark existing commercial blends to understand the limitations of the present fuels to allow for advanced engines and applicability to hybrid, et al, engine developments.

It would be good to apply the characterization methods also to the high distillates that present blenders use to “thrift” the fuel when ethanol is added. There may be impacts (good and/or bad) from these low-quality distillates on any of the compounds identified—the team should establish if they will limit the ability to fully leverage the co-optima fuel fully.

- The HPF group works to better understand the relationship between the fuel's properties and engine performance in an effort to determine new bio-derived fuel options for more efficient engines. The team actively leverages the expertise and data generated by others and uses stakeholder engagement to help guide the analysis. Due to the large and diverse team, communication will be essential to keep the work on track. It is great to see that the HPF group leverages work from other BETO programs and consistently provides iterative feedback between each of the activities.

It will be exciting if the group can capitalize on the unique properties of biomass-derived molecules to produce suitable biobased blendstocks not found in petroleum-derived fuels. The HPF group has been busy. They started by identifying and evaluating over 370 candidate biobased blendstocks. These were down-selected using guidelines developed by the group to 40 high-potential blendstocks meeting the screening criteria. The blending behavior of these 40 materials were measured, and ASSERT was used to select 20 materials for technical analysis. This is an extraordinary amount of work especially since many of these potential blendstocks were not

commercially available and had to be synthesized. Much of the information generated to date has been placed in an online fuel property database which is continually updated to reflect new research and information.

Progress has also been made on Thrust II, including developing criteria for initial candidate identification and testing.

In all of this work, it will be important to evaluate not only the fuel characteristics, but how scalable are they, how much will these fuels cost, and how sustainable are they. Techno-economic analyses and life-cycle analyses should be done on all high-potential fuels. Also, a key challenge to any of these fuels is compatibility with existing infrastructure. We have seen from E15 and E85 that infrastructure can pose a great risk to the deployment of these fuels. Also, it will be critical to understand what impact these materials have on the polymers and elastomers found in the vehicle's fuel system. This will be especially important for the legacy fleet already on the road.

The HPF group's goal, to determine new fuel options afforded by bio-derived fuels, including conversion pathways, for more efficient engines with lower harmful emissions, is highly relevant to today. Today's cars are not maximizing the efficiencies that could be gained due to a lack of octane in the fuel. Optimizing the fuels and the engines could go even further to reducing fuel use, reducing emissions, and strengthening the bioeconomy by creating jobs and spurring rural development. These are worthy goals creating win/win scenarios across the value chain. It will be important, however, to get this information into the hands of decision makers who need to act on it. A strategy to include this information in the Bioenergy Knowledge Discovery Framework (KDF) as well as disseminate it more broadly should be considered. As mentioned above,

techno-economic analyses and life-cycle analyses should be done, as well as compatibility testing with existing infrastructure and vehicle fuel systems. A new fuel may work in engines but may not be a backwards compatible material and would have to be restricted to new vehicles moving forward. I would also recommend considering how much fuel (maximum) can be blended as well as determining the properties at various blending levels of the fuel. I would also suggest looking at the long-term stability of the blendstock as well as multiple blends and not just single compounds.

- This work appears to have gotten off track as it has gone from analysis of co-optimized blends into basic conversion research. Future work appears to be headed back to the stated goals of fuels-related work. It is important to focus on the chemicals and be agnostic to the production processes upstream as the pathways used in the private sector are unlikely to match the laboratory work performed to date.
- This HPF task is arguably the most important part of BETO's portion of the Co-optima initiative. It is generating a highly valuable database of fuel properties of many different compounds that can be derived from biomass. This work represents tremendous effort by all involved and should be commended. It would have been even more interesting when attempting a project of this magnitude (i.e., identifying new fuel components with optimal properties) to have truly started from scratch in assembling the best fuel rather than keeping the predominant petroleum basis with ethanol and only looking for additives to this base as was done here.
- This is well-run work, with a strong, well-organized team, a good management plan, relevant research questions, and management who are effective and promoting collaboration.

The team's goals, go/no-go decision point, and milestones are all well-defined for the next phase of the work. The next phase builds on the first phase

and the presentation demonstrated how the work undertaken in the second phase is responsive to the findings of the first phase.

Moving forward, important aspects of this work are to disseminate results, communicate key findings and lessons learned, and package the models and data such that they can be vetted, used, and contributed to by others inside and outside the DOE laboratories in future projects.

PI Response to Reviewer Comments

- We thank the reviewers for their insights and suggestions in the conduct of the HPF team review. We appreciate their observations including “[t]his is well-run work, with a strong, well-organized team, a good management plan, relevant research questions, and management who are effective and promoting collaboration.” Finally, we are gratified to hear the reviewers agree the “HPF group’s goal to determine new fuel options afforded by bio-derived fuels, including conversion pathways, for more efficient engines with lower harmful emissions, is highly relevant to today.” Their recognition of the “great work and progress in identifying and sourcing a large group of candidates” is also appreciated.

Several reviewer suggestions and questions address project management. First, we will consider moving the annual HPF PI meeting before the beginning of the FY as suggested. Second, two reviewers noted the importance of communication, between Co-Optima teams and within the HPF team, as well as in engaging stakeholders and disseminating the information to the broader research community. We agree, and are developing a more explicit strategy to disseminate our findings broadly, as well as to “communicate key findings and lessons learned, and to package the models and data such that they can be vetted, used, and contributed to others inside and

outside the DOE laboratories in future projects.”

This may include incorporation of this information in the Bioenergy KDF. Finally, we will continue to leverage other BETO programs and provide feedback to them, as suggested.

Reviewers noted the importance of key fuel properties such as stability and compatibility with existing infrastructure. We agree and have more work planned to extend the current work to model and measure the compatibility of high-potential blendstocks with the entire fuel system (including vehicles). This will be especially important for the legacy fleet already on the road. The reviewer suggestion to evaluate stability of blended fuels, in addition to blendstocks, is an excellent one we will incorporate into our work plan.

There were several comments pertaining to blending and thrifting. We agree that determining the impacts of various base fuel components, including low-quality distillates, on Co-Optima blendstocks are essential and plan to evaluate these in FY 2018. The recommendation to consider maximum blend levels, and to measure performance at a range of blend levels is likewise useful. We note that we have blended at several levels already and will continue to do so based on use cases like those seen in the marketplace, and potentially new use cases arising from co-optimization.

The reviewers rightly note the role of techno-economic analysis and life-cycle analysis in determining “how scalable are they, how much will these fuels cost, and how sustainable are they. Techno-economic analyses and life-cycle analyses should be done on all high potential fuels.” We plan to continue to closely collaborate with the ASSERT and MT teams to ensure we understand the cost and sustainability of new blendstocks, and will continue to extend the number evaluated.

The reviewers asked several questions regarding the merit function, integration with VTO-funded teams, and better quantifying potential gains. We will continue to increase integration with the VTO-funded efforts, and evaluate impacts from merit function improvements to better understand how much fuel economy gain could be achieved. We note that we are comparing to commercial fuels in some cases;

further application to hybrid and other drivetrains will require new merit functions.

We thank the reviewers again for their astute suggestions and observations, and plan to incorporate these to ensure the work of the HPF team has the maximum impact and benefit to the full range of stakeholders “creating win/win scenarios across the value chain.”

CO-OPTIMA ANALYSIS OF SUSTAINABILITY, SCALE ECONOMICS, RISK, AND TRADE (ASSERT)

Project Description

The ASSERT team of Co-Optima evaluates the blend-stock and vehicle technologies under consideration within the program from an economic perspective while conducting R&D guiding analyses. The outcome of this team’s work is a common understanding among Co-Optima teams and stakeholders regarding environmental and economic barriers to deployment of co-optimized fuels and engines and routes to overcome them. The team carries out techno-economic analysis and life-cycle analysis of compounds and mixtures considered as potential biomass-derived blendstocks that could increase engine fuel economy when blended with gasoline (e.g., in the case of Co-Optima’s Thrust I for spark-ignition engines). Furthermore, the team investi-

Recipient:	Argonne National Laboratory, Idaho National Laboratory, Lawrence Berkeley National Laboratory, National Renewable Energy Laboratory, Pacific Northwest National Laboratory
Presenter:	Jennifer Dunn
Project Dates:	10/1/2015–9/30/2018
Project Category:	Ongoing
Project Type:	Annual Operating Plan
DOE Funding FY 2014:	\$0
DOE Funding FY 2015:	\$0
DOE Funding FY 2016:	\$2,198,000
DOE Funding FY 2017:	\$2,224,000

gates potential energy and environmental benefits and drawbacks of large-scale deployment of co-optimized fuels and engines through analyses of the vehicle fleet, biorefinery expansion, shifts in the type and amount

Weighted Project Score: 8.6

Weighting: For ongoing projects, there is equal weighting across all four evaluation criteria: Approach, Relevance, Accomplishments and Progress, and Future Work.

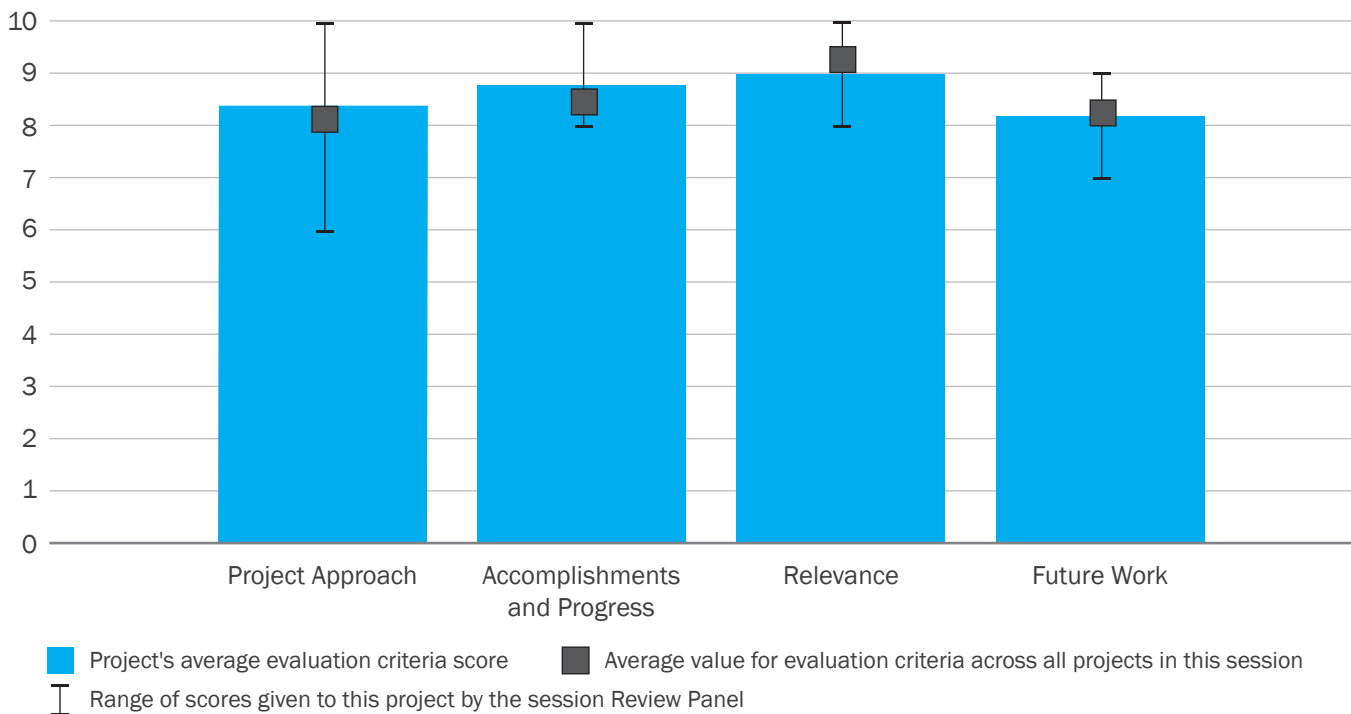

of fuel consumption, and job creation. As part of this impact analysis, ASSERT also investigates how biomass feedstock companion markets may propel biomass from a currently available but largely untapped resource to available in large quantities that meet biorefinery specifications. ASSERT analyses contribute directly to the decision point and inform Co-Optima research teams regarding routes to cutting costs and environmental impacts of potential blendstock candidates.

Overall Impressions

- Overall, the project approach is very exciting and a good combination of industry stakeholder interaction and DOE/national laboratory skill sets. The work appears to be one that is common sense to do and hopefully industry will eventually run with some of the information provided. It appears that the work is well managed on every front with good management and technical approach along with good communication and collaboration. Development of new and existing tools and ASSERT information should provide industry with valuable resources for determining blending feedstock economics to enhance fuel characteristics. The missing link, apparently by design, is how to implement change and provide industry incentives to use the valuable information and tools that will be available for the BETO goals.
- The team is familiar with the industry practice of thrifting the low-value distillates back into the gasoline when the ethanol is added. This artifact needs to have some consideration in regard to commercialization to ensure the same limitations are not put on co-optima fuel. The team should establish if a market model can be defined for the distillate waste so that they could be feedstock for co-optima or made into another product to keep them out of the vehicle fuel.

- The efforts of the ASSERT team form the foundation of all of the other teams. The ASSERT team strives to understand the environmental and economic barriers to the deployment of co-optimized fuels and engines and identify routes to overcome them. If the Co-Optima initiative identifies a novel fuel molecule that can be optimized for a new energy-efficient engine but that fuel is not sustainable, cannot be made at scale, is not economic, or poses a health risk, that fuel will never succeed in the marketplace. That is why this work is so important.

The team is cross cutting and effectively leverages work from other BETO programs as well as uses stakeholder engagement to help guide the analysis. Due to the large and diverse team, communication is essential for keeping work on track. It is great to see that the ASSERT team interacts with the HPF group and other teams to provide feedback as well as get direction from the external advisory board and other key stakeholders. The ASSERT team members have expertise in a wide variety of areas, including techno-economic analysis and life-cycle analysis. This is important, as techno-economic analyses and life-cycle analyses should be performed on all of the high-potential blendstocks developed in the program. Getting sufficient data will be difficult especially on some of the processes that are still at the laboratory bench or pilot scale. However, initial estimates with later refinement will still be important.

The team has already completed analysis on the top 20 potential blendstocks identified by the HPF group. Its analysis showed that all 20 candidates received a favorable rating for fossil energy consumption and feedstock cost and that no single candidate fared unfavorably overall. The data also showed that the early-development stage of many candidates resulted in an unfavorable rating for conversion state of technology readiness, but that candidates at or near commercialization received generally favorable ratings. This is a great start.

As stated earlier, this work is cross cutting and serves as a key foundation to the rest of the work. It also has close ties to BETO's Analysis and Sustainability Program Area, making use of several models developed by BETO. The information generated in this activity will also inform ongoing projects in the Conversion R&D Program's portfolio. The ASSERT team's close ties with the external advisory board and other external stakeholders also help to keep the work focused and relevant. Insights gained through this research into barriers to large-scale deployment of co-optimized fuels and engines can help inform future BETO R&D priorities.

A critical component moving forward will be work regarding potential routes to market adoption and the potential benefits of this adoption. Infrastructure and navigating the regulatory environment will be huge potential roadblocks for the introduction and mass marketing of these fuels. Unique to Thrust II will be the evaluation of costs and sustainability of after-treatment devices. It will be critical to develop a rollout strategy for these fuels including considering the impact of these fuels on the materials of the fuel systems in existing vehicles. If these fuels are for new cars only, how do we overcome the "chicken and egg" problem? If we anticipate a gradual phase in, what would this look like and what would be the major barriers?

- Overall the ASSERT work was very impressive, and it appears that it will contribute a lot of value by focusing efforts into those co-optimized fuels and engines that have the lowest barriers to entry/most potential. Some research into the regulatory hurdles would make this work much more valuable.
- The efforts of the ASSERT team are significant and complement that of the HPF team by analyzing potential fuel candidates by generally non-technical criteria (e.g., environmental, economic, and emis-

sions effects) that are nevertheless important in the overall choice of a viable compound. The techno-economic analysis and life-cycle analysis work is also important. Though the consideration of these factors addressed by the ASSERT team is clear, it would be helpful to more clearly identify exactly how the ASSERT team's analysis and results impact the overall choice of viable fuel candidates by the HPF team.

PI Response to Reviewer Comments

- We thank the reviewers for their comments highlighting the foundational nature of ASSERT's work, and recognizing the importance of economics, scalability, and environmental impacts beyond fuel properties in determining the viability of bio-blendstock candidates. In particular, the comment, "Overall the project approach is very exciting and a good combination of industry stakeholder interaction and DOE/national laboratory skill sets" emphasizes the importance of the multi-laboratory collaboration, DOE support and involvement, and stakeholder interactions. We see engagement with stakeholders as critical to our efforts and we continue to engage with industry through outreach events coordinated with the MT team so that we can inform industry regarding the availability of Co-Optima analyses and tools.

Furthermore, as part of our future work plans, the ASSERT team is working toward a more in-depth analysis with the MT team to understand the value proposition and potential barriers for a range of Co-Optima fuels through the value chain. For the petroleum refiner's perspective, we plan to apply a range of linear programming tools developed under the Analysis and Sustainability Program to evaluate the impact of fuel blending and potential economic viability for the petroleum refiner.

Moreover, we will carry out further analysis of infrastructure and for new cars for a range of Co-Optima blendstocks in collaboration with the MT team. While some compounds may face significant infrastructure hurdles, bio-blendstocks that have similar properties to existing hydrocarbon fuels

may be a somewhat straightforward fit with today's infrastructure. We will consider the advantages and challenges associated with a range of blendstocks across the full value chain and taking into account factors such as the regulatory process, which has been a focus of the MT team.

CO-OPTIMA MARKET TRANSFORMATION

Project Description

Co-Optima will identify improved fuels that in combination with new engine designs will reduce petroleum reduction through greater overall efficiency and substitution of lower-greenhouse gas life-cycle fuels for current market fuels. The MT Team will provide stakeholders with the comprehensive, objective, science-based, and actionable data on engine systems and transportation fuels required to identify the most promising options for large-scale commercial introduction. The stakeholders engage through monthly conference calls, one-on-one visits, listening day activities, and use of an external advisory board. The MT team’s mission is to identify and quantify barriers to the introduction of new fuels and vehicles in the U.S. market. We achieve this through examining the previous successes and

Recipient:	Argonne National Laboratory, Idaho National Laboratory, National Renewable Energy Laboratory, Oak Ridge National Laboratory
Presenter:	Doug Longman
Project Dates:	10/1/2015–9/30/2018
Project Category:	Ongoing
Project Type:	Annual Operating Plan
DOE Funding FY 2014:	\$0
DOE Funding FY 2015:	\$0
DOE Funding FY 2016:	\$1,425,000
DOE Funding FY 2017:	\$1,500,000

failures of fuel and vehicle introduction into the U.S. market and mapping out the steps required to introduce new fuels into commerce. Facilitation of the fuel introduction process with stakeholders is an important focus for the team. Evaluation of biofuel candidate molecules under consideration are being evaluated in six metrics for their suitability/readiness for market introduction.

Weighted Project Score: 7.7

Weighting: For ongoing projects, there is equal weighting across all four evaluation criteria: Approach, Relevance, Accomplishments and Progress, and Future Work.

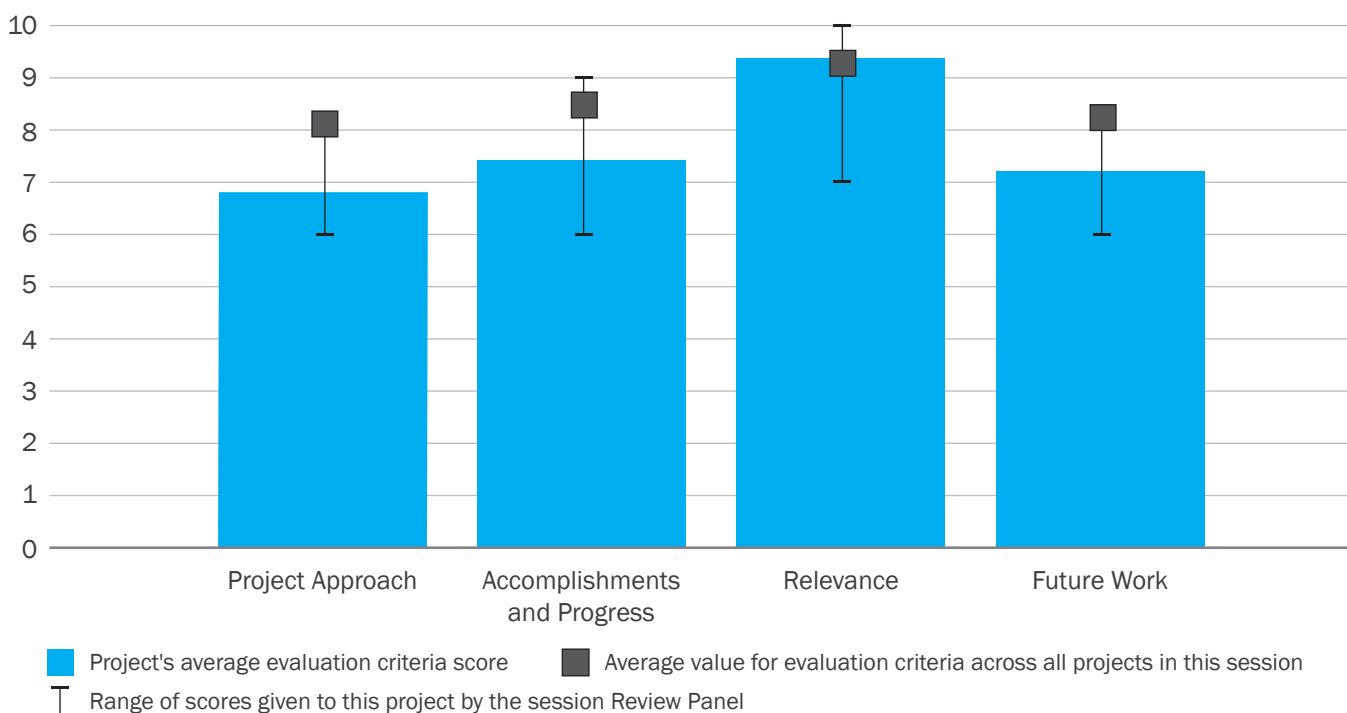

Additionally, market introduction scenario analysis with the Co-Optima ASSERT team demonstrates market acceptability for Thrust I fuel candidates and quantifies Thrust II improvements necessary for driving a second fuel specification.

Overall Impressions

- This is a very exciting project with a good marriage between the chemistry of potential blendstocks for biofuels (and potentially petroleum-based fuel) and engine efficiency. Funding has the potential to affect several industry players rather than promote one company as with other projects. The focus on developing fuel blends specific to increased engine efficiency development takes it one step further (Thrust II). With the practical modeling of economic, environmental, and market metrics for each candidate, this team helps industry as a whole evaluate the potential blendstocks. The work appears to be very well-organized and managed. The missing links, apparently by design, are how to implement change and provide industry incentives to use the valuable information and tools that will be available for the BETO goals. This could make reaching the goals difficult.
- The team is familiar with the industry practice of “thrifting” the low-value distillates back into the gasoline when the ethanol is added. This artifact needs to have some consideration in regard to commercialization to ensure the same limitations are not put on co-optima fuel. The team should establish if a market model can be defined for the distillates so that they could be feedstock for modification/Co-optima or made into another product to keep them out of the vehicle fuel.

There was discussion about how to get the fuel available/launched into the public. I suggest considering a model similar to the natural gas buses as a potential case: hubbed fuel where “users” (employees) just add the fuel. Municipal public transporta-

tion may be a possible microsystem to use to launch Co-optima.

- The MT team’s role in the broader Co-Optima initiative is to enable the introduction of new, co-optimized fuels and engines by facilitating the new fuel standards needed for introduction into the marketplace, identifying vehicle, distribution, and infrastructure compatibility of new candidate bio-blendstocks, and interacting with all market sector stakeholders for technology transfer. This role is make or break for the program.

In general, the Co-Optima initiative is great. It is targeted at the science and the engineering that only DOE can do. But it will not succeed without a strong infrastructure piece and the ability to certify and effectively navigate the regulatory process. This is where this team needs to focus. Identifying and mitigating the challenges of moving new fuels and vehicles into markets will not be easy. It will require engaging with all critical stakeholders (e.g., original equipment manufacturers, fuel producers, distribution networks, gas station owners, UL, regulators, and consumers) as well as understanding and addressing the many hurdles that need to be overcome. The MT team is looking at lessons learned. A key finding from those efforts is that a consistent policy and regulatory environment is critical to the successful introduction of a new fuel. It will be critical moving forward to make sure that supportive policy and regulation is in place to make the transition successful. That was not the case with the introduction of E85 or E15. It is critical that this group focuses on infrastructure compatibility, backwards vehicle compatibility, and developing the necessary codes and standards.

The MT function will determine the ultimate success of this work. Engaging with the appropriate regulatory agencies and standards organizations as well as outside stakeholders will be key. That means having ongoing meetings with the U.S. Environmental Protection Agency and the California Air

Resources Board. It is good to see they are already at the table. If successful, this activity will bring co-optimized fuel and engine technologies to market creating new market opportunities and U.S. jobs in the biofuels industry.

Future work includes analyzing scenarios to maximize stakeholder value for all market segments with the ultimate adoption and acceptance of two fuel/vehicle combinations into the light-duty market beginning in 2025. This is an ambitious and worthy goal. I would also recommend that the group spend some time developing a roll-out strategy even if the pathway to full adoption and acceptance is in stages as overcoming the “chicken and egg” scenario for dedicated fuel/vehicle combinations will be difficult. Tackling the regulatory requirements will also be extremely beneficial to the overall success of the program.

- The MT portion of the work is a critical piece, and its effectiveness will be the biggest determinant for the success of the program. I would like to see a bit more definition as to what would be a successful outcome as it is a bit unclear at the moment.
- The inclusion of an MT team in the Co-optima initiative was a good decision since they will help in the transfer of new fuel and engine specifications to industry and the marketplace. This is no small task and likely an uphill battle no matter how good the results in other parts of the Co-optima initiative because of the general inertia of industry to change, particularly when there may be no clear financial advantage to certain key players such as fuel distributors and the petroleum industry. How to achieve buy in from these infrastructure entities is in fact a key challenge and risk for the Co-optima initiative. Active engagement of all stakeholders and documentation of what was and was not successful in past related efforts, which constitutes a major effort for the MT team, are essential for success of the overall initiative.

PI Response to Reviewer Comments

- We thank the reviewers for their thoughtful comments and suggestions regarding the Co-Optima MT team review. Your acknowledgement and recognition of the importance of MT activities is appreciated, and your suggestions will help us improve the Co-Optima initiative.

It is our responsibility to develop value propositions for all of the market sectors. They will enable us to identify the possible incentives that provide drivers for market place change and a successful Co-Optima fuel/vehicle introduction.

The reviewers adeptly pointed out the dilemma of how to introduce a new fuel and a new vehicle simultaneously into the market, and their insight is appreciated. Overcoming the “chicken and egg” scenario will indeed be difficult, as the lessons learned studies highlighted. Exploration of fleet introduction where the ability to provide controlled access to fuel/fueling options can be better managed is a good suggestion. We agree that the model’s cases of natural gas fleets and municipality fleets are indeed good ones to analyze and learn from. Other market introduction strategies will also be explored through our market introduction scenario analysis task currently underway this FY and will help us develop a pathway(s) to full market adoption and acceptance as a longer-term goal.

The reviewers’ emphasis on the importance of engaging with regulatory agencies as well as those who influence policy and regulations is appreciated. The current levels of engagement with the U.S. Environmental Protection Agency and the California Air Resources Board have likely been sufficient to date, but we would agree that we might need to increase interactions with others such as other California and Canadian agencies in order to develop appropriate, consistent standards across multiple regions. We see that the Co-Optima team can facili-

tate the development of a new fuel specification and the process required to meet the regulatory requirements. The intent to first develop a finished fuel specification based on the co-optimized fuel properties will need to be sufficiently rigorous to address the reviewer comment regarding the effects of the distillate portion composition.

We acknowledge the importance of infrastructure and vehicle backwards compatibility and agree with

the reviewer comments. We have focused effort to date on understanding the level of compatibility for potential bio-blendstocks. The team using the Co-Optimizer metrics will determine any necessary cost/value trade-offs, and whether the affected stakeholders would be supportive of changes that would be needed on a case-by-case basis.

ANALYSIS AND SUSTAINABILITY



TECHNOLOGY AREA



CONTENTS

INTRODUCTION.....	552
A&S OVERVIEW.....	552
A&S REVIEW PANEL.....	554
A&S SCORE RESULTS.....	555
A&S REVIEW PANEL SUMMARY REPORT.....	556
A&S PROGRAMMATIC RESPONSE.....	560
OPTIMIZATION OF SOUTHEASTERN FOREST BIOMASS CROP PRODUCTION: A WATERSHED SCALE EVALUATION OF THE SUSTAINABILITY AND PRODUCTIVITY OF DEDICATED ENERGY CROP AND WOODY BIOMASS OPERATIONS.....	562
PATHWAYS TOWARDS SUSTAINABLE BIOENERGY FEEDSTOCK PRODUCTION IN THE MISSISSIPPI RIVER WATERSHED.....	566
GREET DEVELOPMENT AND BIOFUEL PATHWAY RESEARCH AND ANALYSIS.....	569
STRATEGIC ANALYSIS SUPPORT.....	572
REFINERY INTEGRATION.....	575
RESOURCE ASSESSMENT OF SUSTAINABLE BIOMASS THROUGH FOREST RESTORATION.....	578
SYSTEMS ANALYSIS AND MODELING.....	582
ECONOMIC ANALYSIS OF RISK.....	586
BIOPRODUCTS TRANSITION SYSTEM DYNAMICS.....	591
LAND USE CHANGE DATA AND ANALYSIS.....	595
BIOFUELS NATIONAL STRATEGIC BENEFITS ANALYSIS.....	598
BIOECONOMY ANALYSIS.....	602
GCAM BIOENERGY AND LAND USE MODELING AND DIRECTED R&D.....	606
IMPACT OF PROJECTED BIOFUEL PRODUCTION ON WATER USE AND WATER QUALITY.....	609
INTEGRATED LANDSCAPE MANAGEMENT.....	612
BIOFUEL AIR EMISSIONS ANALYSIS.....	615
NREL INTERNATIONAL SUSTAINABILITY.....	618
FORECASTING WATER QUALITY AND BIODIVERSITY.....	621
COLLABORATIONS TO ASSESS LAND EFFECTS OF BIOENERGY.....	625
CARBON CYCLING, ENVIRONMENTAL & RURAL ECONOMIC IMPACTS OF COLLECTING & PROCESSING SPECIFIC WOODY FEEDSTOCKS IN BIOFUELS.....	629
BIOMASS PRODUCTION AND NITROGEN RECOVERY.....	632
BIOENERGY SUSTAINABILITY: HOW TO DEFINE AND MEASURE IT.....	636
SHORT-ROTATION WOODY BIOMASS SUSTAINABILITY.....	640
ENABLING SUSTAINABLE LANDSCAPE DESIGN FOR CONTINUAL IMPROVEMENT OF OPERATING BIOENERGY SUPPLY SYSTEMS.....	644
BIOFUELS INFORMATION CENTER (BIC).....	648
BIOENERGY KNOWLEDGE DISCOVERY FRAMEWORK.....	651
CEMAC: MARKET ANALYSIS OF BIOMASS-BASED CHEMICALS SUBSTITUTIONS—NREL.....	654

INTRODUCTION

Six external experts from industry, academia, and other government agencies reviewed 27 projects in the Analysis and Sustainability (A&S) session.

This review addressed a total U.S. Department of Energy (DOE) investment value of approximately \$48 million, which represents approximately 6.8% of the Bioenergy Technologies Office (BETO or the Office) portfolio reviewed during the 2017 Project Peer Review. During the Project Peer Review meeting, the principal investigator (PI) for each project was given between 15 and 30 minutes (depending primarily on the project's funding level and relative importance to achieving BETO goals) to deliver a presentation and respond to questions from the Review Panel.

The Review Panel evaluated and scored projects based on their project approach, technical progress and accomplishments, relevance to BETO goals, and future plans. This section of the report contains the results of the project review, including full scoring information for each project, summary comments from each reviewer, and any public response provided by the PI. Overview information on the A&S Program Area, full scoring results and analysis, the Review Panel's summary report, and BETO's programmatic response are also included in this section.

BETO designated Kristen Johnson and Alicia Lindauer as the A&S Technology Area Review Leads. In this capacity, Ms. Johnson and Ms. Lindauer were responsible for all aspects of review planning and implementation.

A&S OVERVIEW

BETO is committed to growing a bioenergy industry that enhances energy security, promotes environmental benefits, and creates economic opportunities. To that end, the A&S Technology Area addresses the challenges related to sustainable bioenergy production and use by supporting analysis, data collection, modeling, and applied research and development (R&D) projects. This technology area works collaboratively with industry, academia, national laboratories, nongovernmental organizations, other agencies, and international partners.

This technology area plays a crosscutting role within and outside the Office. It contributes to portfolio planning and works with other BETO technology areas to develop and advance technology-specific sustainability and analysis objectives. Externally, it contributes scientific knowledge and tools related to understanding and enhancing the economic, environmental, and social effects of advanced bioenergy.

A&S Support of Office Strategic Goals

The Sustainability strategic goal is to understand and promote the positive environmental, economic, and social effects and reduce the potential negative impacts of bioenergy production activities.

The Strategic Analysis strategic goal is to provide context and justification for decisions at all levels by establishing the basis of quantitative metrics, tracking progress toward goals, and informing portfolio planning and management.

A&S Support of Office Performance Goals

Sustainability: Sustainability activities support the Office's strategic goals by providing science-based quantification of the sustainability of advanced bioenergy and promoting improved environmental performance and social benefits of bioenergy relative to conventional or business-as-usual energy systems. The Sustainability portfolio interfaces with and impacts all elements of the biomass-to-bioenergy supply chain and each stage

of technology development. Considering sustainability early in technology development—rather than after systems are finalized and replicated—enhances the future economic and technical viability of those technologies. Sustainability activities closely align with the feedstock and technology pathways pursued under the Office’s R&D and market transformation areas.

Strategic Analysis: Strategic Analysis activities are designed to support Office decision-making processes and advance scientific understanding in crosscutting areas. Supported activities validate decisions, ensure objective inputs, and respond to external recommenda-

tions. Other projects in the Strategic Analysis portfolio strive to advance the state of the science within areas such as life-cycle analysis (LCA), land-use change (LUC) modeling, and bioenergy impact analysis. BETO provides ongoing analysis and policy-relevant support to other U.S. government agencies and legislative bodies. Emerging issues, interests, and trends raise new questions from a wide variety of stakeholders including DOE management, members of Congress, other federal agencies, and state governments. Scholarly articles, popular media, and other broader forums are additional sources of questions for analysis.

A&S Approach for Overcoming Challenges

BETO has identified the following key challenges for achieving the goals of the A&S Technology Area:

Sustainability Challenges and Barriers

- Sustainability data across the bioenergy supply chain
- Consistent and science-based message on bioenergy sustainability
- Science-based methods and tools for evaluating and improving sustainability
- Capturing social and environmental benefits in bioenergy’s value proposition
- Social acceptance and stakeholder engagement
- Land use and interactions with agricultural, forestry, and natural systems
- Best practices and case studies on sustainable bioenergy production

Strategic Analysis Challenges and Barriers

- Comparable, transparent, and reproducible analyses
- Analytical tools and capabilities for system-level analysis
- Data availability across the supply chain

The A&S Technology Area works to overcome these challenges by developing and disseminating knowledge, tools, and mechanisms for more-informed decision making and better resource management. Key partners include national laboratories—primarily Argonne National Laboratory (ANL), Idaho National Laboratory (INL), the National Renewable Energy Laboratory (NREL), Oak Ridge National Laboratory (ORNL), and Pacific Northwest National Laboratory (PNNL)—academia, nongovernmental organizations, industry, and

international organizations. This technology area coordinates internally and externally, working closely with other BETO technology areas, DOE offices, and federal agencies, such as the U.S. Department of Agriculture (USDA), U.S. Environmental Protection Agency (EPA), U.S. Department of Defense, and U.S. Department of Transportation. Robust stakeholder engagement—through workshops, roundtables, and other means—helps advance crosscutting objectives.

The scope of A&S projects includes the following:

- **Resource and technical assessments** that provide the analytical basis for program planning and evaluation of progress
- **Market and impact analyses** that focus on understanding the impact of R&D and bioenergy industry development
- **Advancement of scientific methods** and models for measuring and understanding bioenergy sustainability across the full supply chain
- **Dissemination of practical tools** for analyses, decision making, and technology development that enhance sustainable bioenergy outcomes
- **Data compilation** to develop and maintain tools to assist in collecting, compiling, and analyzing data
- **Quantification of improved environmental performance and social benefits** of bioenergy relative to conventional or business-as-usual energy systems

- **Development of landscape design approaches** that increase bioenergy production while maintaining or enhancing ecosystem, economic, and social benefits

These activities contribute to a better understanding of environmental, economic, and social aspects of bioenergy. A key priority is to analyze trends and trade-offs across multiple supply chain components and sustainability categories.

Outcomes from A&S Technology Area activities are disseminated through publications, web tools such as the Bioenergy Knowledge Discovery Framework (KDF), interagency coordination, and domestic and international stakeholder interactions. They are also used by BETO to inform technology research and development to maximize beneficial outcomes.

For more information on the A&S Technology Area, please review the A&S chapters in BETO's 2016 *Multi-Year Program Plan*.³⁶

A&S REVIEW PANEL

The following external experts served as reviewers for the A&S Technology Area during the 2017 Project Peer Review.

Name	Affiliation
Candace Wheeler*	General Motors (Retired)
David Simpson	EPA, Office of Policy
Christopher Galik	North Carolina State University
Troy Hawkins	Eastern Research Group Inc.
Ruben Lubowski	Environmental Defense Fund
Kate Behrman**	Colorado State University

* Lead Reviewer

** FSL reviewer borrowed for feedstock sustainability projects.

³⁶ U.S. Department of Energy, Bioenergy Technologies Office (BETO), *Multi-Year Program Plan* (BETO, March 2016), https://www.energy.gov/sites/prod/files/2016/07/f33/mypp_march2016.pdf.

A&S SCORE RESULTS

Average Weighted Scores by Project

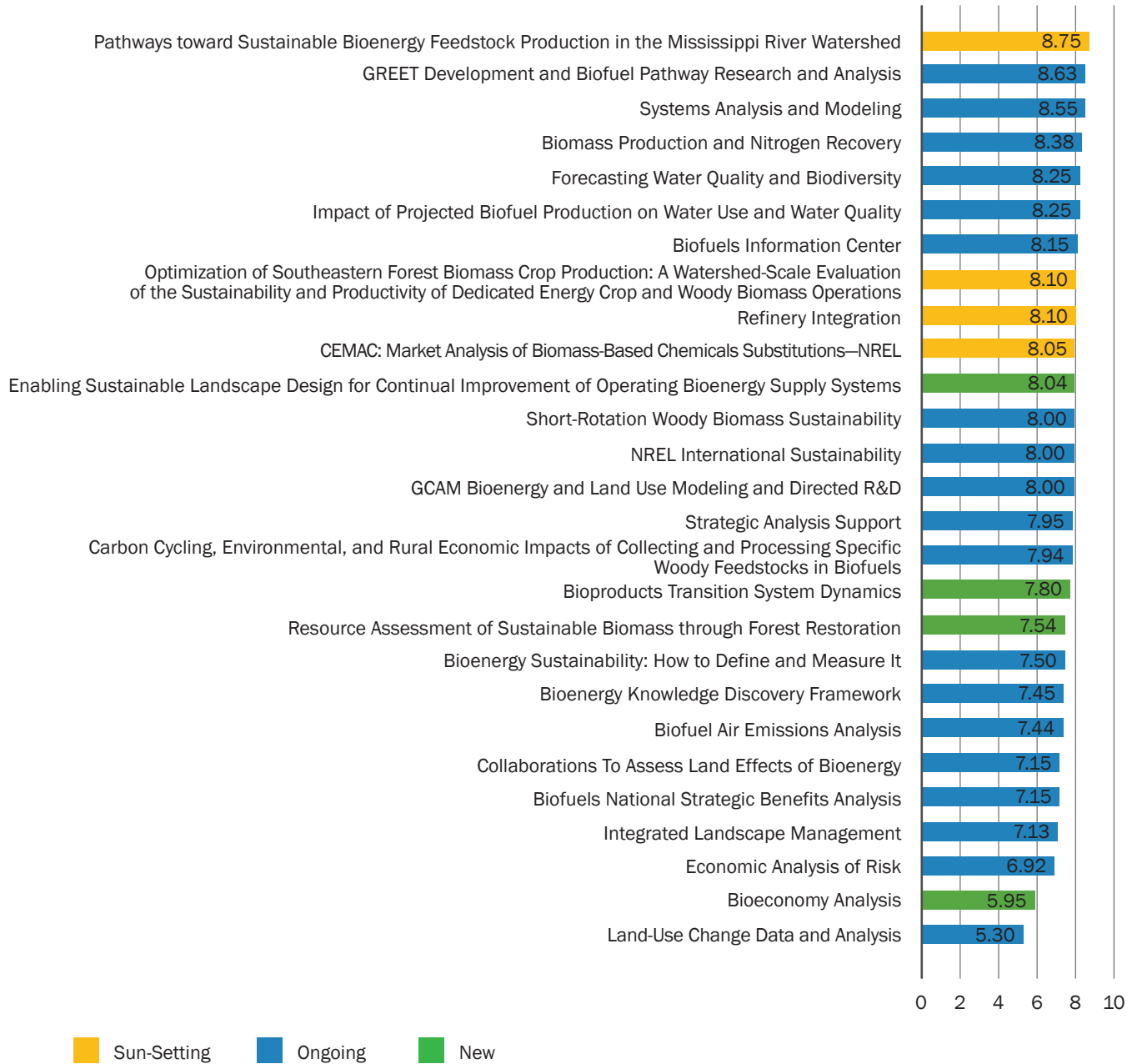

A&S REVIEW PANEL SUMMARY REPORT

Prepared by the A&S Review Panel

Introduction

The A&S Program plays a key enabling role in the overall BETO portfolio. It is crosscutting and forms the foundation for other technology areas by focusing on the environmental, social, and economic impacts of the growing biofuels and bioproducts industries. The Review Panel reviewed a total of 28 projects over 3.5 days. The Panel would like to begin by thanking the PIs for their hard work, innovation, and presentations. The Panel was very impressed with the depth and breadth of the projects as well as the diversity and significance of the projects individually and as a whole.

The Panel found the project management to be very effective both at the program level and project levels. Given the diverse nature of the projects, this is not an easy task but one that was accomplished with great dedication and leadership. Great efforts toward collaborating, communicating, goal setting, meeting milestones, and validating the work were evident. The projects showed solid designs, methodologies, and stakeholder engagement. Of particular note was the outreach to stakeholders and industry which helped to ensure the projects were relevant and timely as well as demonstrated a clarity of goals and purpose.

In the following summary, the Review Panel addresses six key questions looking at the impact, innovative nature of the projects, as well as synergies between the projects in the portfolio. The Panel also addresses the current focus of the portfolio in an attempt to identify gaps or areas that should be deemphasized as well as how these projects translate into commercialization. Finally, the Panel offers recommendations for strengthening the portfolio in the near to medium term.

Impact

There is no doubt that the A&S portfolio is designed to have significant impact. The *2016 Billion-Ton Report: Advancing Domestic Resources for a Thriving Bioeconomy (BT16)* highlighted the depth and breadth of the A&S Program and provided an opportunity to use the tools and capabilities developed in this program on real world scenarios in a more integrated approach. *BT16* illustrated the importance of the sustainability issues in the bioeconomy and the critical nature of understanding the environmental, economic, and social impacts of the system. Understanding the impacts on greenhouse gas (GHG) emissions, water use, and LUCs as well as job creation, rural development, and energy security of significant bioenergy production as outlined in *BT16* would not have been possible without the tools and methodologies developed by this program.

Impact is the key strength of this program. It serves as the foundation and a partner for all of the other program areas. Its tools and methodologies are used across BETO to deliver the information and analysis critical to decision making and optimization both at a higher strategic level and at the fundamental pathway or project technology level. While the expertise and output from this group has been used over the years by researchers to determine the impacts of various technologies and in optimizing technologies around economics and environmental goals, in recent years, the emphasis and expertise has been expanded to look at the social aspects of the bioeconomy as well.

The Panel felt the A&S portfolio showed the right balance between redundancy and independence in work across projects. The Panel noted much better integration and collaboration within and between projects in the program. Researchers from numerous institutions collaborated on many of the projects bringing with them their unique expertise and collective wisdom. Some have criticized the A&S Program in the past for its extensive reliance on government national laboratory

employees with fewer projects awarded to university and industrial partners. However, this also illustrates this technology area's impact. Much of the work is outside the capability and expertise of private industry. Tool development requires a massive effort and is outside the scope and time constraints of industry. Therefore, programs such as this one are the only places where this type of fundamental, precompetitive work can be accomplished. The work being done in this program is significantly advancing the knowledge and capabilities in this area. The program has been able to develop a core group of highly skilled experts to do this work while still leveraging a variety of industry and external partners. These external partners, in turn, provide direction and ensure relevance to the projects.

Analytical methodologies and tools are critical to providing quantifiable results. The tools developed by the A&S program have been integral to providing an "apples-to-apples" comparison of technologies and their outcomes. Tools like the Greenhouse Gases, Regulated Emissions, and Energy Use in Transportation (GREET) model have been used by EPA and other agencies in enforcing regulations such as the Renewable Fuels Standard (RFS). A big push since the last review has been made to make more of these tools publicly available. Getting these tools into the hands of more researchers will increase the impact many fold.

While the bulk of the work in the A&S Program offers exceptional value, the Review Panel found several areas that stood out from the rest. One example of these is the LCA and techno-economic analysis (TEA) work done throughout the program. Models such as ANL's Impact of Projected Biofuels Production on Water Use and Water Quality and its GREET model are examples of this work. This work has long been a backbone of the program and continues to produce high-quality analysis used by industry and regulators. It was evident to the Review Panel that efforts have been made in the last two years to make sure the models are compatible allowing for the integration of the findings for a more robust analysis.

A second area of exceptional value is in Systems Analysis and Modeling. The systems work helps to provide a broader picture and understanding of the market implications and policy influences of various technology developments. This work helps to solidify and integrate much of the other work being done and serves as a critical tool in strategic decision making and direction.

Another area to receive high marks was the Clean Energy Manufacturing Analysis Center (CEMAC): Market Analysis of Biomass-Based Chemicals Substitutions. While a sun-setting project, the project aligns well with BETO's goals to develop a deeper understanding of bioproduct markets, economics, and sustainability and illustrates the ability to use the expertise developed in the program to address a specific issue. The study went beyond just techno-economic considerations to include market drivers and sustainability metrics in the evaluation. The findings confirm that biobased chemicals and bioproducts could serve as an enabler for the biofuels industry by helping to mature the biomass supply chain and provide initial wins for the bioeconomy.

Finally, the Review Panel would like to recognize the impact that good communications plays in the bioeconomy. Efforts through the Biofuels Information Center (BIC), as well as standard setting and international engagements, are instrumental in translating the good work done through the program into actionable intelligence and decision making. Strong research is only good if the information makes it into the hands of those who use it to make a difference in the world. We applaud the A&S Program's efforts to provide access to scientific-based information and engage in informing and influencing the ongoing bioeconomy debate.

Innovation

The Panel observed a maturing of the projects as well as the capabilities and expertise associated with these projects. The A&S Program has spent years developing and improving on the models in their tool kit. This work is coming to fruition. While there continues to be new

areas such as bioproducts that need to be added to the models, the models themselves are now being used to perform strategic analysis and impact decision making. This is a huge win for the program, but it also requires some change in direction as some of the work shifts from model development to utilization.

The core team of experts assembled by the A&S Program is optimally positioned to respond to changes in direction, new innovations, and short-term requests as well as long-term research needs. This was aptly demonstrated by the changes made in the portfolio since the last review. The A&S team was quick to respond to BETO's change in direction by looking at bioproducts and their impact in the bioeconomy as well as including social (e.g., job creation or rural development) and other sustainability indicators. The methodology and tools developed by the program are innovations in their own right. They are, however, being utilized to assess and compare new technologies to ensure these innovative processes are sustainable.

The Review Panel deeply appreciates the A&S Program's efforts to expand and include more qualitative and hard-to-measure aspects of sustainability including social aspects in its analysis. This is itself innovative and leading edge.

Synergies

The Review Panel observed a great deal of collaboration evident in the projects, much more than was present two years ago. There was significant data sharing and a high degree of interaction between laboratories and external partners. Principal researchers from multiple laboratories were co-investigators and contributors to the projects. A great deal of effort was made to make sure data created by one project could feed into or inform another. This level of synergy does not happen spontaneously but was obviously encouraged by BETO management.

It was particularly noteworthy to see examples of data generated in one project used by a second project. It was also gratifying to see the modeling work move toward

common outputs that could be easily used by other systems. This type of interaction and effort aided in enabling the synergy of the projects and should continue to be encouraged moving forward.

One suggestion that was made by the Review Panel was to develop a road map of the various projects in an effort to see where each project lies and how they interact. The leadership informed the Review Panel that this effort was currently underway. We would encourage the leadership to complete this exercise as it helps not only in identifying synergies but also gaps in the portfolio.

Focus

In a program such as A&S, it is critical to understand the bigger picture not only to ensure collaboration and consistency across the projects but to identify gaps in the program. The A&S Program is by nature a complex, diverse set of issues, methodologies, and tools. It would be easy in this vast program area to lose focus. The A&S Program management has been particularly adept in covering the depth and breadth of the sector while maintaining a clear focus and synergy.

All of the projects within the portfolio were clearly aligned with BETO's goals and the milestones of the technology area. The Review Panel did not identify a lot of gaps in the portfolio—the recent addition of biochemical and bioproducts along with the increased focus on social indicators are two examples of previous gaps addressed since the last review. Increased communications and stakeholder engagement were also gaps that were successfully identified and addressed.

The Panel applauds the work on optimizing landscape design and notes that LUC continues to be an issue. While much of the initial assertions have been disproved, obtaining clear and rigorous scientific data will help in making meaningful contributions to this issue.

Risk mitigation is also an area that could benefit the bioeconomy. While complex, understanding various decisions and/or regulatory influences and how to mitigate

the risks associated with these actions would help to move the sector forward.

Commercialization

A successful project goes beyond the technology employed and requires an understanding of the environmental, social, and economic ramifications of the technology. That is where A&S plays a significant role. While the methodologies and tools developed as a part of this portfolio are not themselves being commercialized but are instead being offered for use publicly, the rest of the projects in BETO rely heavily on the expertise of the A&S team to help move toward commercialization. The A&S team provides the nascent technologies with the TEA, LCA, and other methodologies to determine the sustainability of the process—something most start-up technologies are unable to provide for themselves. This access to expertise not only speeds the commercialization of the technology but ensures that the process is optimized for sustainability.

In addition, the Panel observed a greater focus on communication and making the work publicly available. Examples of this included more model releases, data availability, reports and publications, greater use of the Bioenergy KDF, BIC, standards work, stakeholder meetings, and forums. Sharing of this information will help industry to move forward more rapidly and get these new biobased technologies into commercialization quicker.

The consortium approach of some of the projects was great and should be encouraged. This approach allows a wide diversity of disciplines to work together in a multidisciplinary manner. But more importantly, it enables industrial involvement in the research and a stronger connection to the ultimate customers of the research.

As mentioned previously, the deliverables of the A&S portfolio go beyond knowledge generation, but includes tool and method development. The Review Panel was pleased to see that much of this work is being released and used publicly.

Recommendations

First, investigators need to make clear where their projects fit relative to other BETO projects and the A&S Technology Area's goals. A&S leadership is currently working on mapping of all of its projects which will help visualize how each of the projects link together. It will also help visualize any potential gaps or opportunities and make clear what the ultimate value or significance the projects bring. When asked to define relevance, many PIs showed which BETO goals their project addressed. This shows that it is aligned with BETO's mission but does not make it relevant. A PI should know not only how their project fits relative to other BETO projects but how it fits in the bigger picture. A PI should be required to address what problem their work is going to solve as well as how their work will matter and make a difference. This would help to ensure that the meets an actual need and is not just intellectually exciting.

Second, while much progress has been made, there needs to be a greater focus on integration. While increased collaboration has helped drive an increase in integration, more could be done in this area resulting in more robust and multifaceted projects. This is particularly important with the maturity of many of the analytical models. The maturation of some of the models developed as part of the A&S platform will necessitate a slight shift from further tool development to the application of these tools on critical real world issues, problems, or scenarios. Achieving a good balance between further tool development and application is required.

Finally, there needs to be a clear attempt at consistency and agreement across projects especially in how sustainability is measured with a continued push to look not just at the environmental issues of sustainability, but the economic and social aspects as well. These three legs of the stool should not be treated separately but together. We applaud the leadership's efforts to include more social impacts and other hard-to-quantify impacts into

the portfolio's projects. We also applaud their impetus to strengthen communication and integrate the science

generated by the program into the bioeconomy debate at the local technology and global levels.

A&S PROGRAMMATIC RESPONSE

Introduction/Overview

We thank the Peer Review Panel for their time, active engagement, and constructive review of the A&S portfolio. We appreciate the reviewers' recognition that the portfolio is designed to have significant impact and the tools and methodologies developed by A&S are used to inform decision making at strategic and project levels. The Peer Review Panel recommendations will be used to further enhance the effectiveness of the Technology Area's activities and contribution to the Office's goals.

In setting the agenda for reviewers, projects were grouped according to their general area of focus:

- Bioenergy sustainability
- Environmental analyses (i.e., water, biodiversity, and air)
- GHG/life-cycle analyses
- Market and integrative scenario analyses
- LUC modeling
- International considerations and collaborations
- Feedstock production and landscape design (both agricultural and forestry).

The 2015 Peer Review Panel provided several recommendations for the A&S Technology Area to act on, and the 2017 Peer Review Panel recognized the progress made on those recommendations. This year's reviewers specifically called out improvements in communications and stakeholder engagement, an increased focus on social indicators, and the addition of biochemicals and bioproducts in our scope. We are pleased that we have

been able to continue to build an effective portfolio and that our efforts to implement feedback since 2015 have been fruitful.

The reviewers also praised the improved level of collaboration between projects. We appreciate the recognition of significant data sharing and interaction between laboratories and external partners. Researchers from multiple laboratories were co-investigators on various projects, and efforts were made to ensure that data created by one project could feed into or inform another. The reviewers noted how *BT16* volume 2 on environmental effects was a significant achievement that highlighted the depth and breadth of the tools and capabilities developed by the A&S Program. We will continue communicating these tools and capabilities to a wider audience.

Reviewers provided feedback on each project within the A&S portfolio and, in response, PIs are working to address this project-specific feedback to strengthen their future work plans. The reviewers also provided feedback to the overall A&S technology area, which was organized into three general recommendations. BETO technology managers for A&S greatly appreciate these recommendations and are already incorporating these suggestions into priorities for FY 2018 and beyond.

Recommendation 1: Clarify Where Projects Fit Relative to Other BETO projects and the Program's Goals

The reviewers called on investigators to better communicate and clarify where their projects fit into the bigger picture. We greatly appreciate this feedback, and we recognize that even if a project provides significant value, this value is undermined if the PI cannot clearly articulate the project's contribution to larger programmatic

and/or industry goals. As BETO technology managers, we will work to provide clearer guidance to PIs on how they should illustrate their relevance, and we will define clearer expectations for PIs to clearly articulate the problems they are working to solve and the impact of their work.

One effort we have undertaken over the past year is a model and tool “mapping” project that has created a holistic framework to summarize the range of models and tools in the A&S portfolio. While this effort began prior to the Peer Review, we did not yet have concrete visualizations. We now have a robust summary of laboratory modeling capabilities, as well as visualizations of those capabilities and interlinkages between modeling efforts. The database and diagrams will be used to improve communication between BETO and laboratory researchers as well as with external audiences. We envision that these diagrams will be used by PIs moving forward to show how their project relates to the bigger picture and their unique capabilities in addressing research questions, as well as how they interface with other modeling efforts.

Recommendation 2: Greater focus on integration

The reviewers, while recognizing how increased collaboration has helped drive an increase in integration, recommended continued focus toward more robust and multifaceted projects. Reviewers also noted that some of the program’s analytical models have matured to the point where there should be less emphasis on development and more emphasis on application of the tools on critical real world issues, problems, or scenarios. We agree with the reviewers’ recommendation to adjust focus toward application, and we have begun incorporating this into our FY 2018 plans. For example, we plan to downshift development of the Biomass Scenario Model (BSM) and instead will convene working groups involving BETO and national laboratory staff to facilitate application of BSM to address high-priority analysis questions. Furthermore,

we will support efforts to publicly release the Feedstock Production Emissions to Air Model (FPEAM) so it can be applied to real world issues by decision makers. With regard to increased integration, we will continue efforts to integrate TEA and LCAs of biofuel pathways; for example, we will continue the supply chain sustainability analyses that are coauthored by ANL, INL, NREL, and PNNL, and we will apply this integrated strategy to look at more pathways that include high-value co-products.

Recommendation 3: Establish consistency and agreement across projects

While reviewers recognized the progress that was made since the 2015 Peer Review, the reviewers called for greater consistency across the projects in terms of how sustainability is measured, as well as a continued push to investigate the social and economic issues of sustainability, in addition to environmental aspects.

With regard to economic and social effects of bioenergy, A&S is already planning several analysis efforts in FY 2018 to understand and quantify the job effects and other economic benefits of advanced bioenergy. We are also pursuing an integrated LCA methodology that can consider environmental, social, and economic impacts in a more holistic manner.

We recognize that greater consistency is needed not only within BETO but also across different agencies. We are now playing a larger role in the A&S interagency working groups under the Biomass R&D Board to facilitate more consistency and communication across agencies. Additionally, collaborations continue through International Energy Agency (IEA) Bioenergy, specifically on the Measuring, Governing, and Gaining Support for Sustainable Bioenergy Supply Chains project, which covers environmental, economic, and social dimensions and includes diverse international researchers and perspectives. These efforts will help facilitate more consistent terminology, methodologies, and understanding of bioenergy sustainability nationally and internationally.

OPTIMIZATION OF SOUTHEASTERN FOREST BIOMASS CROP PRODUCTION: A WATERSHED SCALE EVALUATION OF THE SUSTAINABILITY AND PRODUCTIVITY OF DEDICATED ENERGY CROP AND WOODY BIOMASS OPERATIONS

(WBS #: 1.1.1.101)

Project Description

The goal of the project is to develop and disseminate science-based information for sustainable production of biofuel feedstock in a forestry setting in the Southeast. The project seeks to quantify the impacts of interplanting switchgrass between rows of loblolly pine trees on hydrology, nutrient dynamics, soil quality, flora and fauna populations, and habitat quality using

Recipient:	North Carolina State University
Principal Investigator:	George Chescheir
Project Dates:	9/30/2010–9/30/2016
Project Category:	Sun-setting
Project Type:	FY 2010–Feedstock Sustainability: DE-FOA-0000314
Total DOE Funding:	\$2,092,892

watershed and plot-scale experiments. In addition, the project documents the productivity of the system and the additional costs related to site preparation, planting, fertilization and harvesting the interplanted switchgrass. The project uses the field data to develop and test watershed and regional scale models that simulate the competition between trees and switchgrass and predict switchgrass yield as well as the quantity and quality of water draining from the system. Field experiments showed that some impacts to hydrology, water quality, soil quality, and biodiversity were observed in response to field operations to establish switchgrass, but impacts

Weighted Project Score: 8.1

Weighting: Approach–25%; Relevance–25%; Accomplishments and Progress–50%.

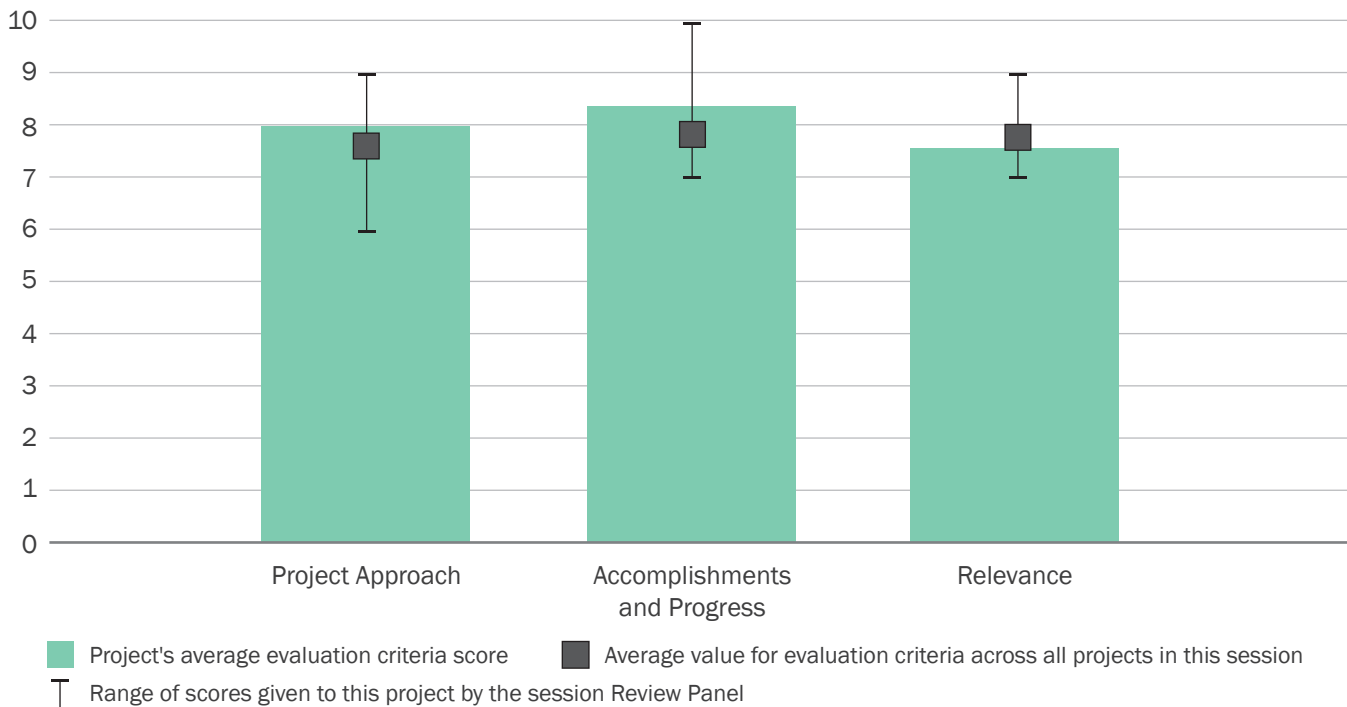



were small and short lived. Best management practice (BMP) guidelines were developed for environmental sustainability. The project, however, also documented the limitations of switchgrass production in the forestry setting, and the challenges and increased costs arising from this practice. These challenges led to the conclusion that intercropping switchgrass with pine trees is not economically feasible in the current economic climate.

Overall Impressions

- Switchgrass was selected for intercropping between pine trees. While in hindsight, this was not an optimal choice, the idea of using the land area between the trees to provide short-term income from an otherwise long-term investment has its merits.

The project was highly leveraged and received good collaboration between a wide array of governmental, academic, and industrial partners. The management approach was clearly defined with regular meetings and an unrestricted flow of information and ideas between collaborators. The project was ambitious and involved extensive data collection. It looked at the hydrology of different energy crop production systems, quantified the nutrient dynamics of energy crop production systems to determine the impact of these systems on water quality, and evaluated the impacts of energy crop production on soil structure, fertility, and organic matter content. The diversity among the local flora and fauna

populations were also accessed among other things. While in the end, the study found that intercropping with switchgrass was not economically viable, it is my hope that the extensive data collected during this study will be used to inform subsequent studies. Understanding the potential for intercropping of a variety of energy crops in different climates and geographies could prove useful in optimizing land use in the future and providing the quantities of biomass required by the growing bioeconomy.

While this project is winding down, the large amount of data collected during the project on everything from hydrology and water quality to soil quality and biodiversity will serve as a foundation for future studies. Also, the application of these data to best management practices and lessons learned will also prove beneficial. It would be helpful to future researchers to know why the team chose switchgrass initially and, if you had it to do over, what would you have picked knowing what you now know. Also, instead of growing an energy crop with the intention of harvesting the crop cost-effectively, what advantages would there be to simply planting a cover crop at the same time the trees are initially planted or collecting what comes up naturally?

- I feel it is important to say something about this project as an example of one that achieved negative results. Too often this may be perceived as a “failure.” It is not. It is good science.

Sometimes there is a tendency when a researcher reaches a negative result to think that s/he should have anticipated the outcome before s/he began, and not incurred the resources to conduct the experiment. I have, in some instances, questioned whether some other projects in their early stages are barking up the wrong tree. The fact that this work passed earlier reviews, not to mention that it was conducted in collaboration with a leading forest products com-

pany, shows that the questions it poses were deemed worth considering.

So, I think it is extremely valuable to have these sort of carefully conducted tests--sometimes knowing what not to do is as valuable as knowing what to do (maybe sometimes even more so). I am going to some length on this, because there is a great deal of concern now in science generally about rampant “p-hacking” (fudging results to make it look like they’re “better” than they are). I think it would send a terrible signal to suggest work like this is not as useful because its results do not support a particular thesis. There is a great deal—arguably too much--of enthusiasm for identifying win-win solutions to environmental and energy problems. These researchers are to be applauded for doing careful work and reporting it candidly, especially if it does not confirm optimistic projections.

- Well thought-out experimental design with extensive data collected at the watershed and field scale on many different aspects of sustainability.
- The project did an impressive job of systematically conducting field and watershed measurements and modeling watershed effects of the impacts of intercropping pine with switchgrass across a variety of water, nutrient cycling, soil, and biodiversity indicators. The project also has an impressive number of publications across a range of topics. One issue is that it is not clear the researchers considered changes in above ground carbon which are essential for sustainability assessment, including the effects of the disturbance to establish the cropping system. Otherwise, the study seems exceptionally rigorous and comprehensive. The study’s rigor with measurement of different site-level treatments and watershed impacts is a model for other assessments.

While intercropped forestry systems could be an important bioenergy pathway, the major question is why intercropping of switchgrass with pine was chosen of the possible technical interventions. This was identified to be non-economic. If there are other systems that might be more commercially viable, perhaps an initial screening or set of quick analyses might have prioritized another system for in-depth study given the ultimate goal to promote commercial bioenergy development.

- The project produced a large dataset and provides insights into the potential benefits and issues associated with real world systems combining woody and perennial grass cultivation systems. The project funded a large research team that collected a substantial amount of data. It is important that the data from this project be documented and shared publicly for use in future analyses.

The project would benefit from striving to also provide information about the economic viability of the system and the interplay between environmental and economic factors. The project is narrow in its focus on the specific intercropping systems considered and the presentation didn’t make clear how the results can be extrapolated to decision making for other proposed bio-feedstock production schemes.

PI Response to Reviewer Comments

- We would like to thank the reviewers for their insightful comments. These comments will help guide us as we finalize manuscripts that summarize this project and offer recommendations for the way forward.

Many of the lessons learned were presented in a published manuscript that summarized the potential and challenges of implementing switchgrass

³⁷ J. Nettles, P. Birks, E. Sucre, and R. Bilby, “Sustainable Production of Bioenergy Feedstock from the Industrial Forest: Potential and Challenges of Operational Scale Implementation,” *Current Sustainable/Renewable Energy Reports* 2, no. 4 (2015): 121–127, doi:[10.1007/s40518-015-0042-9](https://doi.org/10.1007/s40518-015-0042-9).

production in the forestry setting.³⁷ This manuscript laid out many of the factors considered in the original proprietary process of selecting the methods to produce biofuel feedstock in forests. Potential issues considered were energy and feedstock market demands; government policy, mandates, and incentives; environmental effects on biodiversity, water, and soil; carbon fate and accounting methodology; seed source and availability; planting methods and establishment success; switchgrass productivity; competition between pine and switchgrass; equipment and contractor availability; harvesting logistics and efficiency; and transportation costs. When these decisions were being made in 2008, projected market demands, government policies, and technological advancements were somewhat different than those experienced during the life of this project. Nevertheless, the manuscript reports the operational challenges (i.e., number of field entries and equipment constraints), productivity limitations (i.e., impacts of shading, excess moisture, and soil fertility and pH), environmental impacts (i.e., soil compaction, erosion, biodiversity, and nutrient and carbon losses), and economic trade-offs between productivity and environmental impacts (i.e., seedbed preparation versus erosion, delay between tree planting, and switchgrass planting and water quality). Preliminary results of the manuscript suggest that intercropping switchgrass with pine trees can be environmentally sustainable with careful adherence to forestry BMPs, but the productivity of inter-planted switchgrass is less than in agricultural settings despite the increased costs of production.

The effect of switchgrass intercropping on soil carbon and microbial activity was reported in a manuscript by colleagues conducting an allied study not funded by BETO.³⁸ The study found that total soil carbon in the top 15 cm of the soil profile was lower under intercropped switchgrass two years after planting than under conventional pine plantations. Microbial activity, however, was greater under intercropped switchgrass indicating active microbial biomass, which is a precursor soil carbon formation. Longer term studies will need to be conducted to evaluate if increasing microbial biomass offsets the initial decline in carbon under switchgrass.

We are finalizing a manuscript that will more completely summarize the lessons learned in this project and propose alternative systems for more effective biofuel feedstock production in light of recent market conditions and the most recently analyzed data. While the number of systems studied in this project was limited, the range of intensities of feedstock production was quite wide. This allowed us to observe a range of results and to use those observations to develop and test our models. We believe that more effective alternative systems for producing biofuel feedstock in forestry settings will fall within the range of intensities studied in this project. That is, more effective alternative systems will likely involve less-intensive field operations and a feedstock that requires less site preparation and inputs over and above those typically used in conventional forestry.

³⁸ M. S. Strickland, Z. H. Leggett, E. B. Sucre, and M. A. Bradford, "Biofuel Intercropping Effects on Soil Carbon and Microbial Activity," *Ecological Applications* 25, no. 1 (2015): 140–150, doi:[10.1890/14-0285.1](https://doi.org/10.1890/14-0285.1).

PATHWAYS TOWARDS SUSTAINABLE BIOENERGY FEEDSTOCK PRODUCTION IN THE MISSISSIPPI RIVER WATERSHED

(WBS #: 1.7.17)

Project Description

The growing bioeconomy holds great promise for improving the sustainability of transportation, yet many of the environmental effects of industrial-scale biomass production are largely unknown. This project seeks to reduce this uncertainty by employing an ecosystem service framework to evaluate various biomass sources and their placement on the landscape in the economically important and agronomically diverse Mississippi River Watershed. Over the course of this five-year research project, we have explored the effects of biomass produc-

Recipient:	University of Minnesota
Principal Investigator:	Jason Hill
Project Dates:	9/30/2010–12/31/2015
Project Category:	Sun-setting
Project Type:	FY 2010—Feedstock
	Sustainability: DE-FOA-0000314
Total DOE Funding:	\$790,943

tion on climate change, air and water quality, biodiversity, and water and energy use. Among our key findings, we have demonstrated the importance of air quality in bioenergy decision making, identified fertilizer use as a primary target for intervention, shown near-source evapotranspiration recycling for perennial herbaceous crops, and established the strong dependence of impacts on biomass production location. Our project has led to novel advances in environmental assessment including the modeling of two-way interactions between bio-

Weighted Project Score: 8.8

Weighting: Approach–25%; Relevance–25%; Accomplishments and Progress–50%.

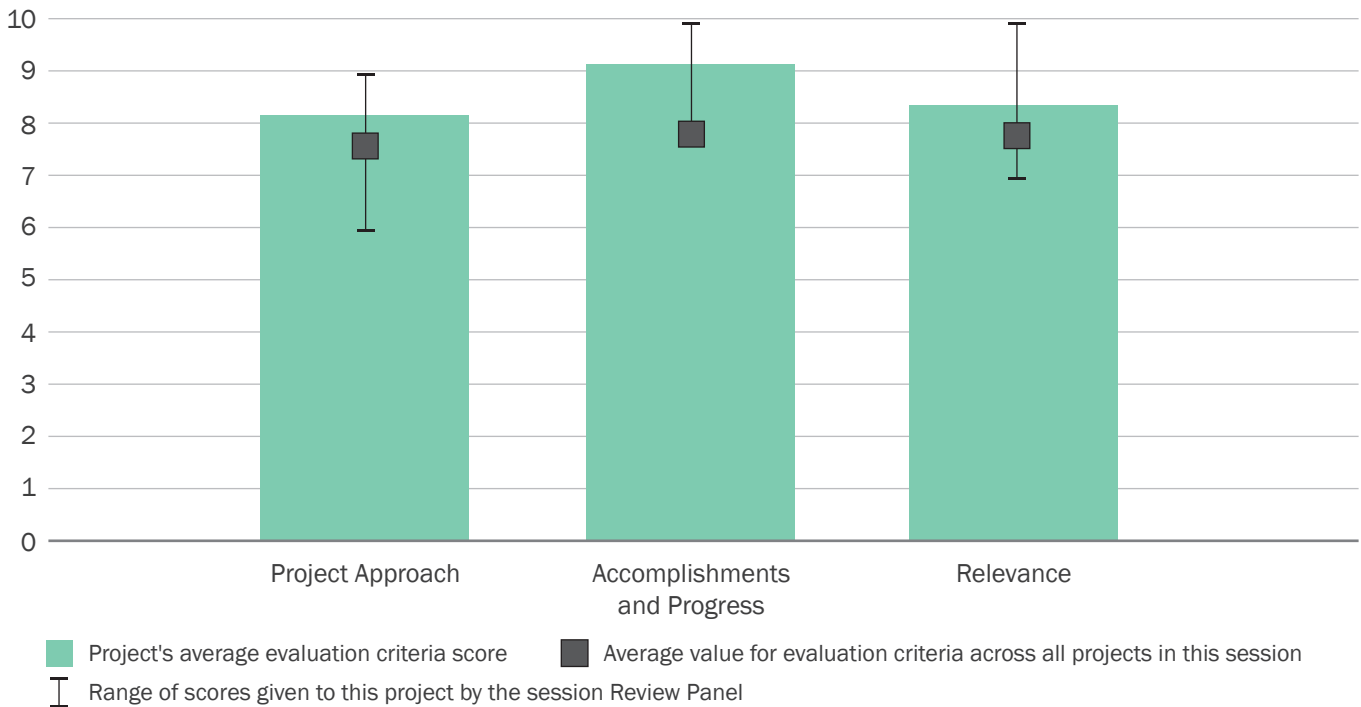

sphere and climate, reduced-form air quality modeling, and advanced methods of spatial LCA and of ecosystem service valuation and incorporation of uncertainty therein. Our work, which has been published in over a dozen peer-reviewed papers, has led to numerous academic collaborations and has received widespread interest from agricultural, industrial, and governmental stakeholders.

Overall Impressions

- The overall goal of this project was to use an ecosystem service framework and integrated modeling approach to evaluate potential environmental effects of various biomass sources and their placement on the landscape. The goal was to inform the growing bioenergy industry to make choices with greater sustainability. The project required minimal management since the team was small and co-located. However, greater collaboration with other BETO researchers may have proven useful. Overall, the project accomplished a great deal including demonstrating the importance of air quality in bioenergy decision making, identifying fertilizer use as a primary target for intervention, and showing near-source evapotranspiration recycling for three different perennial herbaceous crops. Key findings were that the environmental impacts of biomass are highly location specific at a regional level and that switching from urea fertilizer can lessen health impacts. The project covered a wide range of topics and impacts, and the models generated should be useful in future research. The work from this sun setting project has been widely published in over a dozen peer-reviewed papers. In addition to the data generated and the models developed, I think one of the greatest impacts has been in helping BETO and the bioeconomy in general, to look at the issue of sustainability from a different lens. Dr. Hill's findings have helped to stimulate discussions and have shown that where and how you produce biofuels matters. Small changes such as switching fertilizers can have significant impacts. I hope that this research will serve to help the industry make more informed decisions.
 - Interesting project output, filling an important translational role between fundamental technical research and necessary policy dialogue. I would have appreciated a discussion of how the individual analyses fit together and the story they collectively tell, as there is potential that the contribution of this project is more than the sum of its parts.
 - This project has provided exceptional value for investment. By leveraging existing models to answer questions about biomass production, it has addressed questions that might otherwise not have been considered, and done it at a modest overall expenditure. A good portfolio of overall research might contain a handful of projects that overlap on important issues, as well as some that delve into less-explored matters that might still be important. This work does a little of both, with perhaps more emphasis on the latter. In this regard, it represents a cost-effective investment.
 - The project is centrally relevant to BETO's goals of assessing sustainability along multiple criteria. Understanding the heterogeneous nature of environmental impacts is also critical and it would be useful to further explore the implications of alternative policy and market scenarios. It would also be valuable to understand the scale dependence of the results and of associated uncertainties. This is one of the most productive projects in the BETO portfolio in terms of high-caliber publications, especially given the limited personnel. This supports the value of including academic partners.
- It will be important to compare results and maximize learning between the models developed in this project and those in other projects on air, water, and other impacts in the BETO portfolio (e.g. WBS

#s 4.2.1.10, 4.2.1.30, and 4.2.1.40). It would also be beneficial to ensure coordination between this project and the ORNL project (WBS # 4.2.2.40) to define sustainability metrics based on multiple criteria. Additionally, it would be helpful to specify success around a practical application to help inform a stakeholder decision. It would also be helpful to further spell out links with other projects in the portfolio. Finally, it would be valuable to explore ways the models and/or underlying data can be shared on the Bioenergy KDF or another linked open-source platform.

- This is an example of a well-run and successful research effort. The project asked and addressed

important questions using appropriate methods that built on previous work and resulted in the dissemination of knowledge back to the public and biofuels research community.

PI Response to Reviewer Comments

- We thank the reviewers for their comments and positive evaluation. Our project has ended, but we are continuing to publish its results. For example, the Intervention Model for Air Pollution was published on April 19, 2017.³⁹ We look forward to continuing to engage with BETO personnel as we carry this work forward in other projects.

³⁹ Christopher W. Tessum, Jason D. Hill, and Julian D. Marshall, "InMAP: A Model for Air Pollution Interventions," *PLoS ONE* 12, no. 4 (2017): e0176131, <https://doi.org/10.1371/journal.pone.0176131>.

GREET DEVELOPMENT AND BIOFUEL PATHWAY RESEARCH AND ANALYSIS

(WBS #: 4.1.1.10)

Project Description

Since 1994, with DOE support, ANL has been developing the GREET model for LCA of vehicle/fuel systems. Of the more than 100 vehicle/fuel technology options in GREET, biofuel production pathways are an important group. With BETO support in the past 2.5 years, ANL has used the GREET model to examine the energy and environmental impacts (e.g., petroleum use, greenhouse gas emissions, criteria air pollutant emissions, and water consumption) of various biofuel pathways with different feedstocks and conversion technologies. ANL has updated and upgraded the GREET model, added new biofuel pathways, and ex-

Recipient:	Argonne National Laboratory
Principal Investigator:	Jennifer Dunn
Project Dates:	10/1/2014-9/30/2017
Project Category:	Ongoing
Project Type:	Annual Operating Plan
DOE Funding FY 2014:	\$1,275,000
DOE Funding FY 2015:	\$1,462,000
DOE Funding FY 2016:	\$1,462,000
DOE Funding FY 2017:	\$262,000

amined critical LCA issues such as LCA system boundary, co-product methodologies, and indirect effects such as LUC. With nearly 30,000 registered GREET users, ANL continues to interact with key stakeholders including government agencies, fuel/technology developers, and non-governmental organizations to advance understanding of energy and environmental effects of biofuel technologies and utilization.

Weighted Project Score: 8.6

Weighting: For ongoing projects, there is equal weighting across all four evaluation criteria: Approach, Relevance, Accomplishments and Progress, and Future Work.

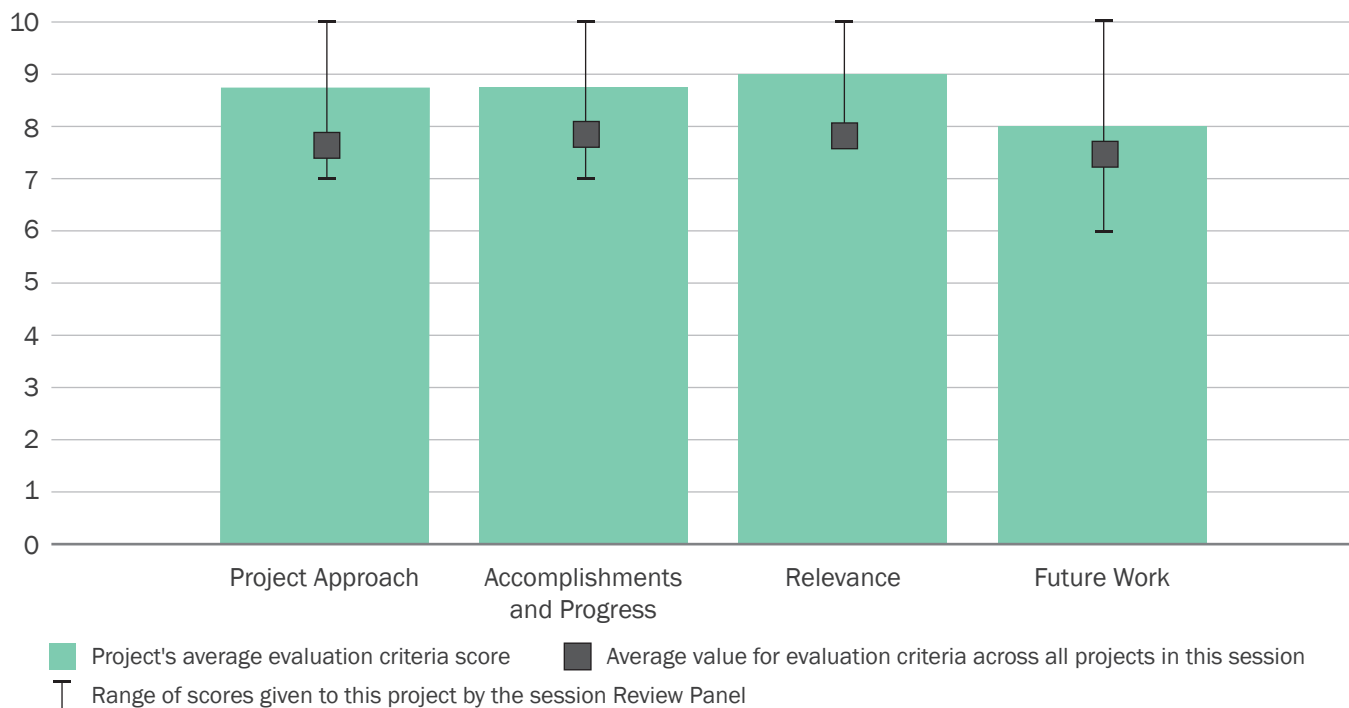

Overall Impressions

- BETO has long supported the development of the GREET model, a LCA tool used to quantify the energy and environmental impacts of biofuels. Today, GREET provides a well validated and rigorous tool to advance the understanding of biofuel sustainability. It is used broadly by the LCA community with nearly 30,000 users and serves as an enabler for policies such as the RFS and the Low Carbon Fuel Standard program. It provides a consistent and comprehensive format to assess the benefits of various biofuels pathways. The project displays a high level of collaboration and integration. Much has been accomplished since the last review. GREET has undergone additional model development including the modeling of LUC and soil organic compound change for biofuel feedstocks. GREET also served as a major contributor to the *BT16* volume 2 sustainability report. Life cycle water consumption and additional co-feedstocks and co-products were added to the model. Of particular interest was the LCA expansion for various production scenarios for algae. This integrates nicely with the efforts BETO is making in the algae space.

GREET provides a platform to integrate the LCA of biofuel pathways to address their overall energy and environmental benefits which is critical for BETO and the rest of the bioenergy community. Future work includes continuing to address farming management practices and their impacts on soil organic compound for biofuel feedstocks, continuing to expand key GREET modules and GREET functionalities, and continuing to monitor and expand emerging biofuel conversion technologies. An effort will be made to regionalize the GREET well-to-wheels analyses of criteria pollutants and water stress assessment as well as extend LCA for different algal cultivation and fuel processing pathways to provide R&D guidance to BETO and the biofuels

community. It will be important to remain focused on the most critical issues. I do feel, however, that adding biobased chemical and biobased products to the model would be useful as these materials are enablers of the bioeconomy with many early examples already in commercial production.

- GREET is ubiquitous in biofuel sustainability analysis, and the project team continues to produce relevant and necessary analysis. My only suggestion is that the project team communicates more clearly how they will continue to pursue the most critical issues and analyses in future work.
- While, taken as a whole, GREET represents a tremendous achievement, it in its current state it also raises some important concerns for the management of the BETO portfolio. Something in excess of \$7 million has been spent to date in the development of GREET and it appears to have been money well spent. As the final roughly \$1.5 million allocated to the project is committed, however, it begs some questions:
 - After spending as much as has been, what remains to be done?
 - If the answer to the previous question is “a lot,” were earlier priorities chosen wisely?

If it's the case that earlier spending priorities were appropriate but a lot still remains to be done, what is the comparative advantage of doing the work under the auspices of the GREET platform, as opposed to by others, after which results might be integrated into GREET?

It is not entirely clear to me, however, how important the work now being taken up for GREET is (albedo?). Some scrutiny should be applied to ongoing expenditures. Related to this, several other projects refer to the use of their results in GREET. This testifies to the usefulness of GREET as a platform, but complicates the task of the reviewer. How

should credit be assigned between the creators and maintainers of the GREET platform itself and the teams contributing to its extensions?

- This project is of central relevance to BETO's goals by providing a consistent comparison platform to assess sustainability across multiple dimensions. Moreover, given the wide recognition and use of GREET, it is important to ensure ongoing improvement to reflect the best available science and the project should be commended for striving to do so. Particular high priorities in this respect are the identified next steps of assessing the temporal dynamics of forest feedstocks under alternative assumptions, and comprehensively evaluating the issues of carbon neutrality and additionality. The inability to address these issues left notable gaps in *BT16* volume 2 report, and it will be important to be able to continue developing capacities to be able to address them within the BETO portfolio.

To ensure the best available information, it is also essential that the project draw on the best evidence from the other parts of BETO portfolio.

A key consideration is how best to characterize and report uncertainties and spatial (and temporal) heterogeneity of results to provide a more detailed picture of life cycle impacts appropriate for different policy objectives.

Integrating GREET and associated visualization could also be a priority for the Bioenergy KDF.

PI Response to Reviewer Comments

- ANL has maintained regular communication with BETO sponsors and interactions with other national laboratories and the bioenergy community. Our analysis priorities are determined annually based on these efforts. For example, our LCA work is designed to serve BETO's 2016 *Multi-Year Program Plan*, 2016 *Strategic Plan for a Thriving and Sustainable Bioeconomy*, and State of Technology

Assessment, as well as to address emerging issues government agencies and the biofuel community bring into discussion.

Thanks [to the reviewers] for bringing up the BETO resource commitment vs. critical issues in the LCA space. This single annual operating plan is a significant resource commitment by BETO. However, this annual operating plan could have been separated into several topical areas, each of which could require significant efforts to address (e.g., the assessment of indirect effects such as LUC, soil organic compound dynamics, forest feedstock carbon dynamics, the algae technology pathway assessment, and regional water and air emission effects). While GREET development is part of this annual operating plan, it is not the driver of analytical topics and issues. In fact, it is analytical topics and issues that determine ANL research priorities and GREET model development is our last step so that the bioenergy community can use GREET to examine the issues we have analyzed.

We agree with the suggestions as our future plan reflects some of these comments. Speaking of characterizing and reporting uncertainties and spatial (and temporal) heterogeneity of LCA results, we have addressed uncertainties and variations in GREET LCAs methodologically and analytically. We will need to continue this effort to address regional variations at a finer resolution as we move to address environmental issues such as criteria air pollutant emissions and water consumption of biofuel feedstocks and conversions. Note that one of the main goals of GREET.net development is to address and display spatial heterogeneity of LCA results. The temporal heterogeneity, on the other hand, has not been addressed as thoroughly as spatial variations, partly because time series data are often difficult to obtain, especially for newly emerging technologies. Extra efforts should be made on this aspect in the future.

STRATEGIC ANALYSIS SUPPORT

(WBS #: 4.1.1.30 and 4.1.2.30)

Project Description

The NREL strategic analysis project portfolio encompasses a wide set of analytical tools and expertise in support of the BETO. Started in 2010, this set of projects work to develop models and methodologies used to assess the technical, economic, and societal impacts of the development and implementation of bioenergy technologies. These models serve as an analytical basis for program planning and evaluation of progress. Specifically, these efforts include (1) an estimation of job growth and the economic impacts of bioenergy production; (2) the TEA of the strategic expansion of hydrocarbon fuel technologies, including to jet fuel production; (3) a market analysis to identify key drivers and hurdles for near-term industry growth of bio-derived chemicals;

Recipient:	National Renewable Energy Laboratory
Principal Investigator:	Mary Bidy
Project Dates:	10/1/2010–9/30/2018
Project Category:	Ongoing
Project Type:	Annual Operating Plan
DOE Funding FY 2014:	\$600,000
DOE Funding FY 2015:	\$545,000
DOE Funding FY 2016:	\$650,000
DOE Funding FY 2017:	\$500,000

and (4) assessing the value of bio-derived blendstocks to petroleum refiners.

Utilizing high-quality data that are thoroughly documented and vetted is critical to the success of these tasks. We work with key stakeholders (e.g., policymakers, bioenergy technology developers, and investors) in developing and reviewing the results of these analyses. Uncertainties associated with the analysis efforts are clearly defined and quantified.

Weighted Project Score: 8.0

Weighting: For ongoing projects, there is equal weighting across all four evaluation criteria: Approach, Relevance, Accomplishments and Progress, and Future Work.

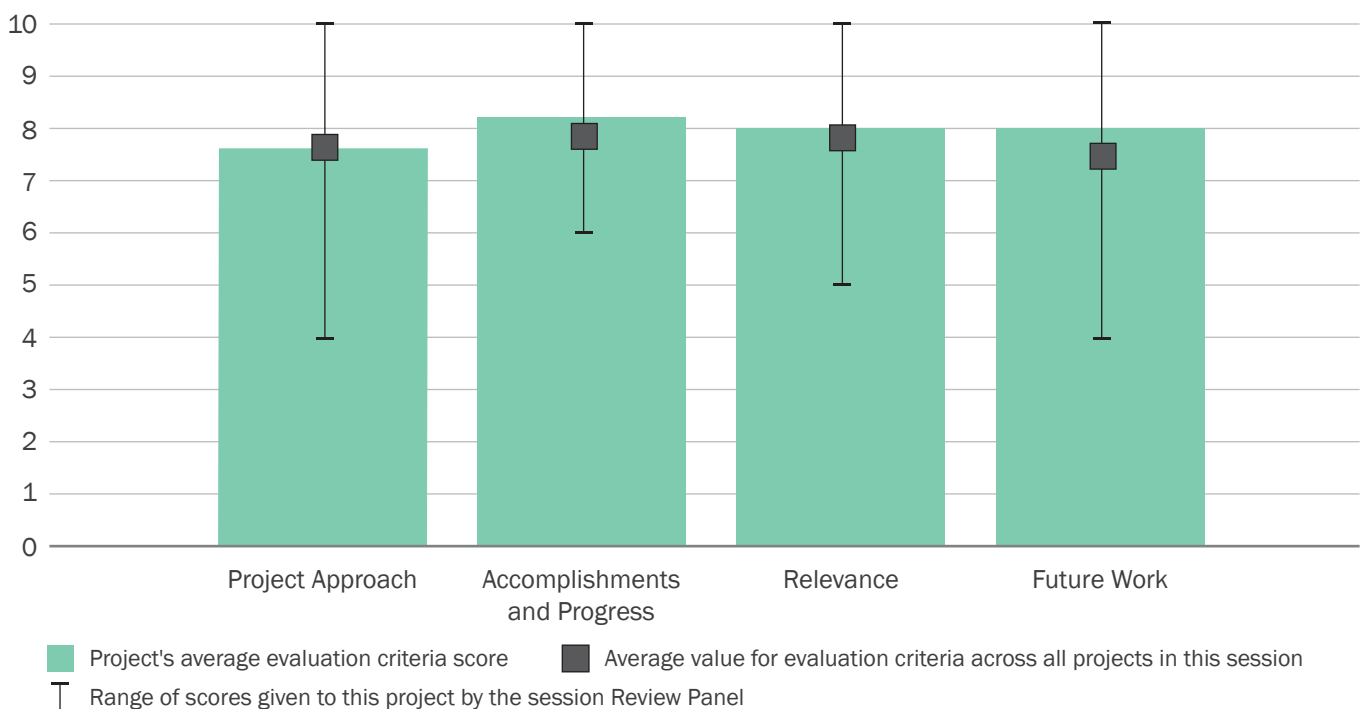

Overall Impressions

- The goal of the Strategic Analysis Support group is to develop and utilize an array of analysis tools to support the strategic direction of BETO and understand the development of a biomass economy. The types of analyses range from assessing the current and future market drivers for the production of biomass-derived chemicals to providing comparative economic analyses for jet fuel production pathways. This group utilizes a wide variety of tools and expertise. The project is well managed with clearly defined objectives and milestones. The use of go/no-go decisions has proven effective. Communication and collaboration is critical to the successful hand off of the information in support of other BETO projects. The group has made a great deal of progress since the last review. This progress includes a market report analysis and publication on bioproducts to enable biofuels, the development of TEAs for understanding jet fuel production, support for conversion R&D strategies to understand fuel quality valuation, and jobs and economic development impact (JEDI) case studies to identify key factors that contribute to job growth. Each of these projects is significant by themselves. Together they represent an enormous amount of work which helps to highlight the impacts of the emerging bioeconomy and outline specific hurdles or gaps for further development by BETO and industry. One good example of this is the market analysis report for the production of bio-derived chemicals. This report identified 27 biomass-derived products which were down-selected to 12 products based on market potential. The emerging area of biobased chemicals and bioproducts has the potential to produce some short-term wins that could spill over to the broader biofuels market. This report was a great example of the type of research done by this group.

The relevance of this work is in its ability to provide credible results to assist decision makers in the

bioenergy space by applying appropriate analyses and models. The group provides a go to group for BETO whenever the need arises. The work is often started here and then passed off to others. They have proven they have the ability to provide a quick turnaround on BETO requests. I see this group as being a key enabler of the Co-Optima initiative, and a close collaboration between the two groups is important. Future work includes case studies with JEDI to consider the effect on income distribution, the comparison of biofuel hydrocarbon pathways for near-term scale-up, the development of TEAs for understanding waste stream upgrading, and the assessment of refinery economics due to biofuels blending stream displacement. Given the current interest in job creation, further refinement of the JEDI model to include an analysis of job “shifting” and job loss would give a more complete picture and strengthen the validity of the model.

- This project has yielded obvious accomplishments, but it is unclear how the project strategically aligns with other BETO-funded efforts and whether the project is uniquely qualified to tackle the specific future analyses identified. Perhaps this was a function of the presentation and materials provided to the reviewers, as responses to questions asked by the Review Panel helped address this important issue somewhat.
- This project provides a comprehensive analysis of the economic viability of biofuel and product development. My sense is that the treatment of the demand side of prospective markets is more qualitative than that of the supply side, but this seems appropriate given what are probably the greater uncertainties in the development of potential product markets. The supply side analysis largely takes an “engineering” approach, but again, this is reasonable given the lack of data on the development of required technologies. Employment analysis is always problematic, as one should consider not only

the number of people employed in a new industry, but also the numbers displaced in old ones which the project considers in its future plans.

- Overall, this project seems to have delivered valuable quick-turnaround analytic and modeling capacity to BETO. The project seems well integrated to feed into other BETO projects, including GREET and Co-Optima. Showing the data interconnections among projects would help demonstrate value. Also, it would be valuable to ensure analyses and tools are disseminated on platforms such as the Bioenergy KDF and BIC.
- This is an exemplary project. It is asking the right questions, engaging a broad set of stakeholders, managing the project confidently and collaboratively, working closely with other DOE laboratories, and clearly planning next steps based on critical gaps in understanding. Moving forward, this project should continue to engage stakeholders, looking for additional stakeholders to further strengthen the analysis and expand the broader impacts, and to identify the next key knowledge gaps to inform decision making for policy, investment, and other strategic purposes.

PI Response to Reviewer Comments

We thank the reviewers for their helpful feedback and suggestions. We will continue to work to ensure the analyses and tools developed under this project are disseminated. To start, these project outcomes and models will be posted on the Bioenergy KDF and BIC websites. Moreover, this project strives to provide BETO with critical information and tools to address key questions in support of the strategic direction of the office. This project supports informational needs for a range of BETO-supported projects including GREET and BSM. It is our goal to continue to support our strong collaborations both within the national laboratories (with GREET and BSM) and externally through collaborations with industry and other government agencies. We also plan to integrate details of our bioproducts analyses into the Bioenergy Market Report supported by the A&S Technology Area. Additionally, through our integration with the Co-Optima initiative, there are ongoing efforts to develop methods to estimate ‘net’ jobs analyses which will be incorporated into this project in the future.

REFINERY INTEGRATION

(WBS #: 4.1.1.31 and 4.1.1.51)

Project Description

The project purpose is to evaluate and understand the economic incentives and key cost drivers associated with use of existing refinery infrastructure to produce biofuel hydrocarbon blendstocks. All biofuel design cases are based on standalone plants processing biomass to produce a finished fuel blendstock. However, use of existing infrastructure through integration with petroleum refineries is a means to reduce biofuels production costs. At the start of the project no tools existed to assess the impact of co-processing bio-intermediates with conventional petroleum. The project builds upon separate PNNL and NREL efforts to identify and develop synergistic opportunities for integration of biomass-derived hydrocarbons into existing petroleum refineries. It directly addresses barrier “Petroleum Refinery Inte-

Recipient:	Pacific Northwest National Laboratory, National Renewable Energy Laboratory
Principal Investigator:	Sue Jones, Mary Bidy
Project Dates:	10/1/2011–9/30/2017
Project Category:	Sun-setting
Project Type:	Annual Operating Plan
DOE Funding FY 2014:	\$450,000
DOE Funding FY 2015:	\$400,000
DOE Funding FY 2016:	\$400,000
DOE Funding FY 2017:	\$0

gration of Intermediates.” This project identifies risks, key hurdles, uncertainties, and further R&D needed for coprocessing of a range of bio-derived intermediates including pyrolysis bio-oil, algal hydrothermal liquefaction bio-oil, and algal and biochemically produced lipids. The models completed within this project are AspenPlus models for hydrocracking and fluidized

Weighted Project Score: 8.1

Weighting: Approach–25%; Relevance–25%; Accomplishments and Progress–50%.

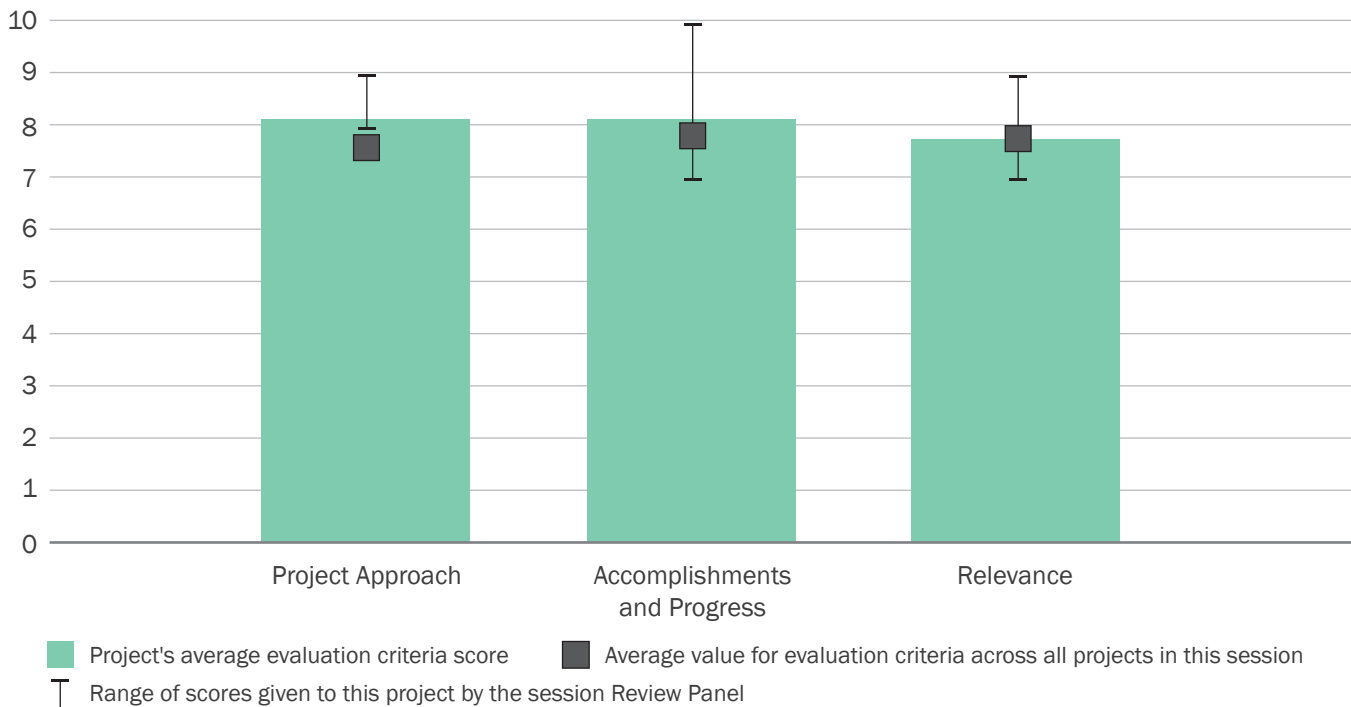

catalytic cracking, and Aspen HYSYS hydrotreating models. Each model was evaluated with and without biomass-derived intermediates. Preliminary modeled results and costs were reviewed by refining contacts and catalyst vendors, and that feedback was incorporated into the cost and performance models.

Overall Impressions

- The goal of the Refinery Integration team was to develop detailed process models of three key petroleum refining conversion systems for converting mixtures of conventional and biomass-derived intermediates and use these to identify costs, opportunities, technical risks, information gaps, and research needs associated with coprocessing. Despite having the work split between two sites, the project was well managed with regular meetings and conference calls that leveraged the capabilities at both laboratories. Because of the nature of the work it was critical to engage outside stakeholders. The feedback obtained by the team from refining experts was necessary to ensure that the models and methods were reflective of the actual refinery operations. While using current refinery infrastructure to co-refine bio-derived materials makes sense, a lack of understanding of the economic viability, value proposition to the petroleum refiner, and technical risk for upgrading bio-derived intermediates remains. This project sought to answer those questions. They did so by developing a suite of models to understand the impacts, opportunities and gaps associated with co-processing. These were first-of-a-kind process models of the hydrocracker, fluidized catalytic cracker, and hydrotreater looking at a variety of biomass intermediates including lipids and hydrothermal liquefaction biocrudes.

Understanding the potential benefits to the refiners helps to determine whether or not co-processing is a viable option and represents a win-win on both

sides. It will also help to address the volumes required to make this cost-effective and worth the risk to the refiner. Certainly, things like reduced sulfur content could help offset the presence of oxygenates and the high acidity normally inherent in bio-oils. However, understanding best practices such as the level of stabilization or upgrading needed prior to entry at the refinery is important. Understanding how much volume is needed and how to optimize the system would also be interesting. While this project is winding down, the models developed in this project will be used in other BETO projects. One such study would be to use the model to address the impact of algal oils if and when that technology ramps up. A highlight was the use of the models to look at the impact of the BT16 scenarios. For the 2017 and 2022 timeframes using the \$60 and \$80/ton scenarios, the models showed that 8–14 billion gallons per year of bio-oil-based production could be made using the least costly route.

- The project seems to have satisfied its objectives. Its goal was defined to be sufficiently limited, and work under the project seemed reasonable to achieve the outcomes set. I appreciate the efforts to transfer tools to other BETO projects and to inform external stakeholders.
- This seems a well done and potentially useful study of the potential to use existing refineries to process biomass feedstocks and their intermediate products. The only real concern I have is that the terms of the analysis be clarified. Specifically, it is important to know if, first, biomass and fossil-derived feedstocks could be used interchangeably, or, in the extreme, miscibly, so as to avoid shut downs for switchovers. Also, it is important to be clear about whether the opportunity costs of foregoing refining of one feedstock is incorporated in the cost of treating the other. I believe that these are both dealt with, but again, clarification would be helpful.

- This seems like a well-defined technical analysis but the larger contribution requires more work to communicate.

It would be helpful to flesh out some initial hypotheses for why biorefinery integration could be a viable pathway and what it would take to achieve this. Then the findings of the study could be used to directly test these ideas and suggest potential policy or other interventions.

The economic break-even analyses seem particularly useful to a policy audience. Key questions are how generalizable they are and how regionally and technologically specific they are. Finding a way to communicate these economics would be very helpful in the dissemination of findings including potentially through platforms like the KDF or BIC. It would also be interesting to consider the portfolio diversification and risk-hedging benefits of biofuels, as per study done with WBS# 4.1.2.41 to understand how this could affect the economics.

- This project is relevant for BETO's mission and considers likely pathways for the integration in our existing fuel supply infrastructure. This project provides new tools for evaluating refinery operation with bio-inputs.

A strength of the project is the fact that it produces first of their kind chemical process models for integration of bio-feedstocks into refinery operations. The collaboration between NREL and PNNL strengthens the output of this project. The project

also engaged suitable reviewers from industry to check the quality and validity of the models. The project met all of its milestones.

It is important to ensure the studies performed in this project are followed through the publication process so they are made available to other researchers for reproduction of results and to be further developed. The publication of the Aspen models is another benefit of the project and it is important to ensure this happens.

PI Response to Reviewer Comments

- We thank the reviewers for their helpful feedback and insights. We plan to build on the foundational work that has begun in the A&S Technology Area project and transition these efforts to support planned experimental work under the core-conversion platform efforts. The feedback provided by the reviewers will be incorporated into these future efforts to address details that could not be dealt with in this project either because of data or time limitations. The anticipated NREL/PNNL experimental project is aimed at addressing a range of issues including, to name a few, the degree of stabilization needed, the impact of different types of processing to produce the bio-intermediate, and miscibility limitations. It is anticipated that the planned NREL-PNNL experimental project will help to fill the data gaps that were identified in this initial A&S project. The related future analysis work will be carried out within existing annual operating plan projects.

RESOURCE ASSESSMENT OF SUSTAINABLE BIOMASS THROUGH FOREST RESTORATION

(WBS #: 4.1.1.52)

Project Description

Sustainable biomass from forest restoration to reduce high fuel loads and fire risk is a potentially significant source of bioenergy with numerous potential benefits including increased ecosystem services such as improved flow regimes for aquatic habitat. A multi-agency collaboration between DOE and U.S. Forest Service (USFS) will use high-resolution spatial vegetation characteristics data to develop accurate estimates of sustainable forest biomass along with distributed hydrological, ecological, and wildfire risk modeling in a multi-objective analysis framework to assess the extent of forest thinning activities that restore landscape function to reduce high fuel loads while increasing biomass yield and stream flow in a publicly and ecologically acceptable manner. We will

Recipient:	Pacific Northwest National Laboratory
Principal Investigator:	Mark Wigmosta
Project Dates:	10/1/2016–9/30/2019
Project Category:	New
Project Type:	Annual Operating Plan
DOE Funding FY 2014:	\$0
DOE Funding FY 2015:	\$0
DOE Funding FY 2016:	\$0
DOE Funding FY 2017:	\$220,000

initially focus on high-fire risk areas in the Pacific Northwest at the sub-basin to regional scale using data, models, and analysis techniques that can be applied nationally.

Overall Impressions

- This project seeks to address an interesting and developing issue. Previous fire suppression policies in the United States have led to dense forests and heavy undergrowth. Having traveled frequently in

Weighted Project Score: 7.5

Weighting: Approach–25%; Relevance–25%; Future Work–50%.

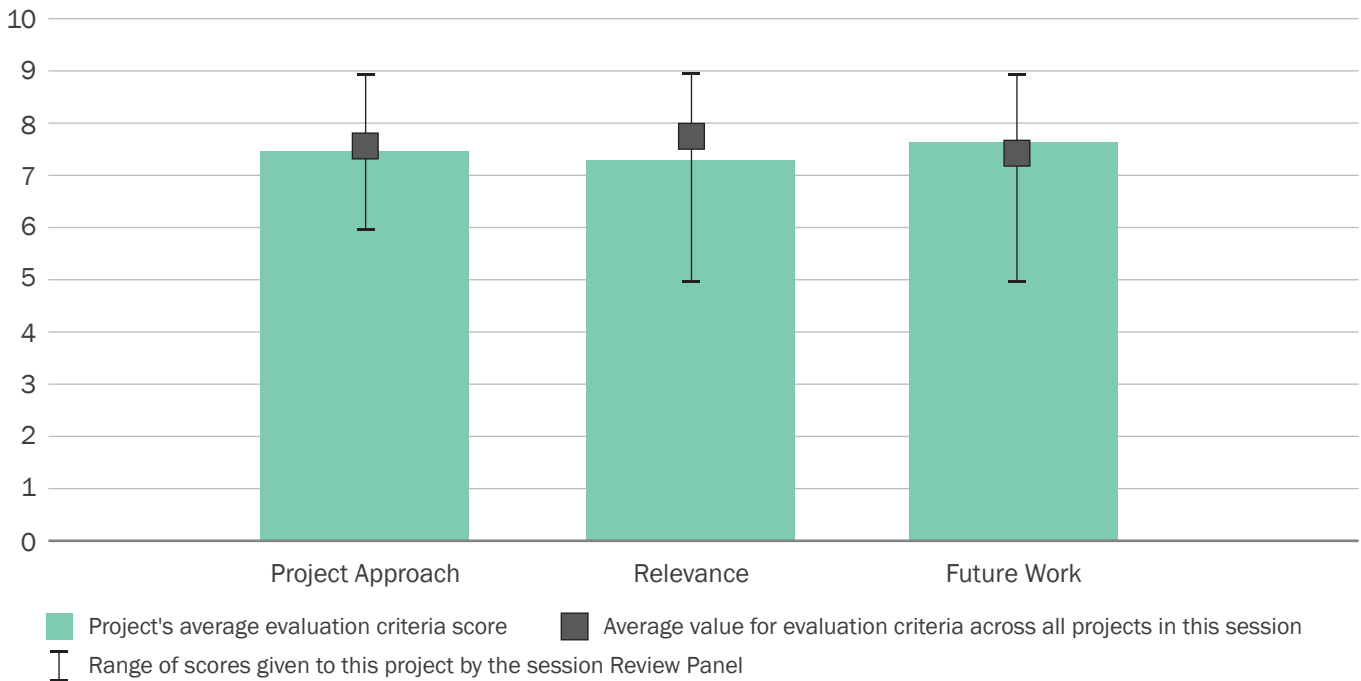

the West, I have seen what happens when a fire gets out of control. This project seeks to develop and demonstrate an analysis framework to prioritize how and where to target forest restoration practices such as timber harvesting and thinning. Such a project would benefit the growing bioeconomy by making large volumes of forest residues and small-diameter trees available for bioenergy while reducing wildfire risk, increasing water yield, and improving ecosystem services. While new, the project appears to have good management practices in place and is a collaboration between various partners. Of interest to me was the fact that increased forest density not only increases fire risks but impacts hydrologic processes such as stream flow patterns and reduced water availability. This project will utilize a linked set of spatial, biophysical models coupled with existing decision support software to identify high fire risk locations for restoration that have sufficient biomass and the potential to increase peak snow-pack duration to improve summer flows critical to fisheries. So, if successful, this project will increase forest-derived biomass availability for the bioenergy industry while improving water flow and aquatic habitat.

In addition to completing the resource database and decision analysis tools, an important milestone will be selecting a demonstration basin for detailed analysis. It will be important to engage outside stakeholders to determine what forest restoration scenarios would be viable. It may be necessary to look at road access, for example, or slope conditions. Whatever forest restoration scenario is proposed, it must be economical and sustainable. In some cases, it may make sense to burn the biomass in place since harvesting it would not be cost-effective. I would urge working with USFS on this. Also, have you clearly defined what sustainability metrics or ecological services will be looked at beyond hydrology? Policy may also play a role here, so looking at various policy interventions could be useful. For example, would the information developed here also apply to national parks?

- This is an interesting project with potential relevance to multiple resource management objectives across multiple stakeholders. I challenge the team to more clearly state how they will coordinate analysis with existing efforts and how they will ensure that outcomes of the project are communicated to critical stakeholders and/or user groups.
- The project argues that there would be substantial ecological and, potentially, hydrological benefits to removing potential fuel from forest areas and using it in biofuel production. Those benefits would, however, arise from any program to reduce fuel accumulation including, presumably, prescribed burning and/or curtailing routine fire suppression programs. It's not at all clear that gathering such materials for use in bioenergy production would be economically feasible. This should be addressed before the project continues, at least under BETO's auspices.
- It does seem profitable to look at forest residue as a feedstock in a sustainability context; however, I don't think that this is where BETO can have its biggest impact on sustainability.
- The project seeks to develop a decision support to help prioritize where to target forest restoration efforts via strategic thinning and prescribed burning, based on benefits for biomass production as well as ecosystem services. The potential use of biomass from forest restoration activities is a potentially important biomass supply pathway and this project will help assess the environmental trade-offs and maximize benefits from societal activities. Presumably, incorporating biomass adds a financial benefit to the forest interventions or possibly reduces the GHG impacts of traditional practices by reducing fire risk and putting the residues to use. It would be useful to quantify these benefits and incorporate the logistics and potential demand for biomass for energy to be able to characterize the potential "win-win-win" opportunities.

The project's goal could also focus more squarely on developing a practical tool for decision making. This will require more explicit discussion of user

needs and decision-making processes and how the tool can provide actionable information.

- The project is well organized and roles are well defined.

The project team represents appropriate skills to accomplish the objectives.

The metrics of success are appropriate and simple enough to maintain focus. Moving forward, it will be helpful to use these metrics to track project progress.

Data management is a key challenge for this project. As the project collects data, it would be beneficial to provide that data in a manner suitable for incorporation in future work by this project team or others.

It would be helpful to engage stakeholders including those representing fire management, forest conservation, and the forest products industry.

PI Response to Reviewer Comments

- We thank the reviewers for their valuable comments. Our project is designed using models, data, and decision support software that can be applied to a range of conditions on public and private forest land across the United States. To be effective in fire risk reduction and economic sustainability, restoration efforts will include significant commercial timber harvest with biomass for energy derived from tree tops and branches, along with non-merchantable small diameter trees. Multi-criteria suitability analysis, including fire risk, topographic landform, slope, aspect, vegetation type, protected areas, and critical channel habitat will be used to initially select potential restoration areas. Local conditions such as slope and existing road access will determine the appropriate method and costs of harvest and the volume of biomass available for energy. In some cases, economics may require some logging residue be burned in place, rather than collected for bioenergy.

This project will use the USFS Forest Inventory and Analysis (FIA) BioSum analysis tool to ensure proposed restoration scenarios that include bioenergy are economically viable. BioSum incorporates a transportation cost model, a treatment cost accounting module, a log valuation model, and a crown fire hazard evaluator with FIA plot data. The model will be used to evaluate costs associated with biomass energy production under alternative restoration scenarios, and compute haul costs to alternative sites at which forest biomass-based energy production facilities could be constructed. BioSum has been used to support biomass plant capacity decisions in Lakeview, Oregon; forest practices policy development by the California Department of Forestry and Fire; and regional analysis of opportunities to attract bioenergy investment capital in New Mexico.

We will utilize the Ecosystem Management Decision Support (EMDS) software in the trade-off analysis and decision-making process. EMDS is the USFS corporate software solution for decision support used by the USFS and U.S. Department of the Interior since 2006 to evaluate wildfire potential across the continental United States and establish priorities for allocating fuel-treatment budgets. Beginning in 2007, this was expanded to include the U.S. Department of the Interior Fish and Wildlife Service, Bureau of Indian Affairs, National Park Service, and Bureau of Land Management. Co-Investigator, Dr. Reynolds has 25 years of experience in development and application of decision support systems, including 21 years as architect and project lead of EMDS. USFS Co-I's Hessburg and Reynolds are the two principal architects of the Okanogan Wenatchee National Forest landscape restoration decision support tool based on EMDS.

EMDS implements a framework to support the functions of a spatially-enabled decision support system that helps decision makers rationally evaluate strategies or solutions for spatial or geographic

problems. These are often complex problems with large datasets, include a high degree of uncertainty, and entail multiple stakeholders with conflicting interests and viewpoints. EMDS is often used to evaluate, compare, and prioritize scenarios or alternatives.

Once our demonstration basin is selected, we will conduct workshops with end users and subject matter experts concerning resources and conditions that must be managed, know how treatments will be applied, and what decisions are needed. We feel

that the role of decision support is not to deliver the answer, but to organize and present information in a way that facilitates informed deliberations among decision makers including those that represent fire management, forest conservation, and the forest products industry. Successful application requires a high level of involvement of senior managers, policy experts, technical specialists, and scientists. The proper planning for a decision environment will enable the building of tools that meet user needs in a direct and efficient manner.

SYSTEMS ANALYSIS AND MODELING

(WBS #: 4.1.2.1)

Project Description

BSM is a unique, validated, state-of-the-art, fourth-generation model of the domestic biofuels supply chain which explicitly focuses on how and under what conditions biofuel technologies might be deployed to contribute to the U.S. transportation energy sector. BSM examines the implications of policies and incentives as well as their potential side effects; uses a system dynamics simulation to model dynamic interactions and transitions across the supply chain; and tracks the deployment of biofuels given industrial learning and the reaction of the investment community in the context of land availability, the competing oil market, consumer demand for biofuels, and government policies over time. Under expected market conditions, scenario analysis

Recipient:	National Renewable Energy Laboratory
Principal Investigator:	Amy Schwab
Project Dates:	10/1/2010–9/30/2017
Project Category:	Ongoing
Project Type:	Annual Operating Plan
DOE Funding FY 2014:	\$1,272,000
DOE Funding FY 2015:	\$1,400,000
DOE Funding FY 2016:	\$1,310,000
DOE Funding FY 2017:	\$1,300,000

based on BSM shows that the biofuels industry tends not to rapidly thrive without significant external actions in the early years. Interventions that lead to operation of pre-commercial and commercial facilities have been identified as having strong influence in starting the growth of a commercial biofuel industry. Policies which are coordinated across the whole supply chain in BSM foster the growth of the biofuels industry and production of tens of billions of gallons of biofuels may occur under sufficiently favorable conditions.

Weighted Project Score: 8.6

Weighting: For ongoing projects, there is equal weighting across all four evaluation criteria: Approach, Relevance, Accomplishments and Progress, and Future Work.

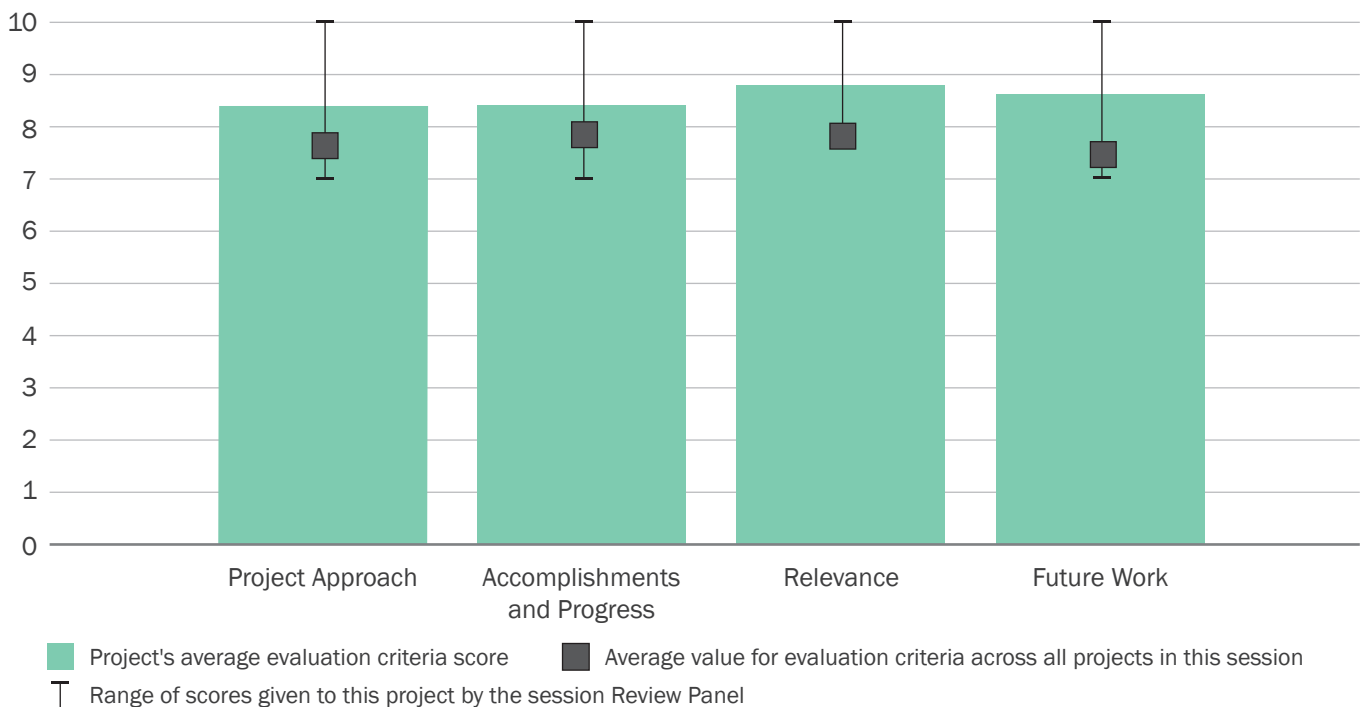

Overall Impressions

- BSM is a system dynamics model of the domestic biofuels supply chain designed to inform stakeholders, management, and policymakers of the implications of policy choices and the impacts of various biomass-to-biofuels scenarios. The model offers the unique opportunity to stimulate discussion and shape thinking across the entire biofuel value chain. The team members have increased collaboration with BETO and other national laboratories as well as outside stakeholders since the last review. This effort is appreciated as is its transparency and careful attention to detail. The team continues to perform impactful analyses designed to inform DOE. One such study looked at the future potential of aviation biofuels. The analysis suggested that six billion gallons of aviation biofuel is possible by 2030.

The team is exploring scenarios of biofuels penetration in marine applications as well. Its work since the last review has included the development of a user-friendly visualization platform for the BSM. This will be especially useful when the model is released publicly later this year. Because the model is intended to inform decision makers it will be important to get the model into the hands of policy and decision makers. Making the model accessible to the public will be a good start. However, the team will need to carefully consider the rollout strategy as its time could quickly get consumed with supporting the training and troubleshooting of other users. Future work will include performing relative analyses in support DOE and BETO goals as well as continuing the development of advanced statistics and visualization capabilities. While the team is not specific as to what relevant topics it will address in the future, I would suggest that adding biobased chemicals and products to the model would be useful as these materials are enablers of the bioeconomy with many early examples such as bio-succinic

acid already in commercial production. Adding the various algal production pathways would also be beneficial.

- In many ways, a model presentation and a model for project management and implementation. Attention to internal model development, technical approach, and quality assurance/quality control are commendable, as is attention to use of the ultimate product and how it can help a wide variety of stakeholders.
- The strength of systems dynamics modeling is to develop scenarios based on plausible interpretations of current circumstances. The weakness is that out-of-sample, as it were, behavior can be driven to implausible extremes. In contrast to economic models (which, to be fair, rely on their own sets of dubious assumptions and have their own weaknesses), there is not necessarily a set of self-correcting behavioral assumptions built in. I've noted elsewhere in remarks on other projects that systems dynamics models need not conform to "Kahn's Law:" "If something can't go on forever, then it won't." My sense, though, is that the BETO research portfolio is strengthened by drawing from a wide range of approaches, and so models like this should be supported so long as they're useful, albeit with (as, again, for any approach) an appreciation of their weaknesses.
- This is a powerful and flexible addition to the BETO toolbox for analyzing a variety of biofuel pathway development scenarios and policies. The project has already made progress on very policy relevant and timely issues, such as international aviation.

It would be valuable to more clearly articulate the strengths and weaknesses of the systems analysis approach. Also, the focus seems to be on production volumes and timing of deployment. It would be important to also ensure that the scenario modeling provides transparent information on the economics, particularly the costs and economic benefits to the

government and private actors. There is also a focus on financial supports for different parts of the industry. It would be important to transparently communicate to what extent these supports are required over time or are temporary measures to kick-start industry development. It also seems important to include consideration of environmental sustainability metrics as outputs of the modeling, as well as associated sensitivity analysis to key parameters, scenarios, and assumptions. It would also be valuable to ensure that scenarios can be analyzed that match current policy discussions.

Finally, the focus on visualization for stakeholders is commendable. The virtual/augmented reality component is also very interesting and innovative, but it would be important to carefully analyze the needs of stakeholders and value added to appropriately balance investment across model development and more sophisticated visualization.

- This is an important part of the BETO A&S portfolio and stands out as a high performer amongst projects in the portfolio. Moving forward the project should continue its collaborative stance with other DOE laboratories and researchers outside the DOE community. EPA and USDA are important stakeholders for this work, it would be appropriate to consider how these relationships could be established more firmly in terms of data flows between research groups and the use of the BSM to answer questions of interest for EPA and USDA policymaking.

PI Response to Reviewer Comments

We greatly appreciate the helpful recommendations made by the reviewers. Indeed, we will be doing an analysis on biomass-based chemicals and bioproducts in FY 2017 and we have plans to expand analysis into other areas such as marine, heavy duty vehicles, and

feedstock exports. The BSM already incorporates algal pathways, as is shown in the supplemental material. We recognize that a public model rollout can be very time consuming. In response, we are engaging with an initial alpha testing group of BSM users prior to release in order to gain a better understanding of different use cases and the best approach for supporting a new user community. With the BSM release, we plan to continue our emphasis on collaboration. We appreciate the suggestion that USDA and EPA are important stakeholders, value our existing relationships within those organizations, and will endeavor to create tighter coordination with them by reaching out to additional organizational units, seeking more direct, extensive, and timely data flow, and exploring analytic opportunities. We also value collaborations with those outside of federal agencies--such as state agencies, industry, and academia--and will continue to seek out opportunities to collaborate with them.

We are aware of the potential value as well as the potential drawbacks of the system dynamics (SD) methodology. Similarly, we are cognizant of the strengths and weaknesses of the methodologies used to form the input data used in the BSM. We have critically and conscientiously addressed those via module-by-module validation, sensitivity analysis, and carefully designed modeling experiments. Where possible, this entails calibration to empirical data. The resulting level of structural detail provides balance in feedback loops where simpler formulations might not, overcoming one of the potential challenges of SD. In general, we only report insights and conclusions that are robust with respect to the quality of the input data and the structural uncertainties in the BSM and that precisely qualify analytic results by stating under which conditions they hold and under which conditions they would be contradicted. One of the strengths of SD its considerable potential to generate multiple system behaviors across different input variable regimes that may offer nuanced answers to hypotheses.

The large variance-based sensitivity analysis of the BSM tackles many questions around policy cost and effectiveness including variations in policy type, magnitude, and duration. We plan to publish multiple journal articles on this analysis and anticipate that they will address comments around policy design and cost. We

appreciate the reviewer's interest in NREL's advanced visualization capabilities that are utilized by the BSM. We will be careful to balance visualization techniques with the needs of stakeholders and prioritize resources accordingly.

ECONOMIC ANALYSIS OF RISK

(WBS #: 4.1.2.20)

Project Description

Inconsistent methods for analyzing risks in the feedstock supply chain lead to high financing costs, which is an investment barrier. The purpose of this research is to create a method investors can rely on to evaluate and price risks in supply chain projects based on industry collaboration. The work establishes standards and protocols for assessing risks in project investment from across the supply chain. The challenge is to ensure that the standards and methods are consistent with industry best practices so that investors, developers, insurers, and other financial stakeholders can be confident in project risk assessment. Researchers develop a framework to categorize, track, and assess overall feedstock supply chain risk in a project and build a stochastic techno economic model to quantify logistics cost risk in the supply chain. Applying the model, researchers have quantified

Recipient:	Idaho National Laboratory
Principal Investigator:	Jason Hansen
Project Dates:	10/1/2013-10/31/2018
Project Category:	Ongoing
Project Type:	Annual Operating Plan
DOE Funding FY 2014:	\$250,000
DOE Funding FY 2015:	\$150,000
DOE Funding FY 2016:	\$250,000
DOE Funding FY 2017:	\$570,047

uncertainty in a unit operation within the supply chain and translated it to a logistics cost to assess risk. Then, for a supply chain design, researchers identified the impact of uncertainty in feedstock quantity and quality on biofuel prices. This work supports BETO's mission of commercial viability in bioenergy, and its crosscutting goal for metrics and methods for understanding risks. Most importantly, the project creates a better, consistent method for analyzing risks, which supports breaking down the investment barrier.

Weighted Project Score: 6.9

Weighting: For ongoing projects, there is equal weighting across all four evaluation criteria: Approach, Relevance, Accomplishments and Progress, and Future Work.

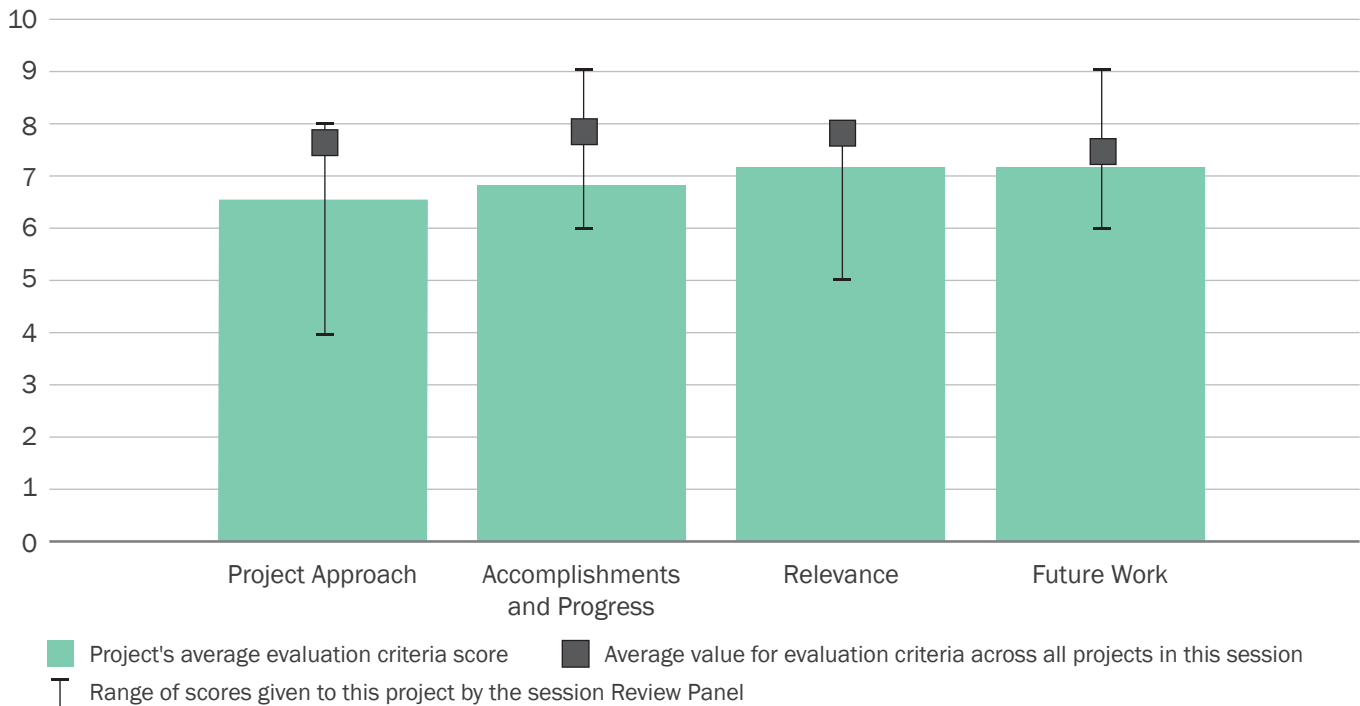

Overall Impressions

- Today, a consistent method for comparing and pricing risk across project options in the biomass supply chain does not exist. This creates a barrier to investment. This project seeks to create a method to systematically analyze, measure, and compare risks in a way that is consistent with best practices so that investors can evaluate project risks. One of the strengths of the project is its close ties to the financial sector. While the management approach was not clearly defined, the team's desire to produce transparent, reproducible results is noteworthy. While this (renamed and refocused) project has just recently gotten underway, the team has begun to look at the primary cost and uncertainty drivers in preprocessing based on cost and equipment type. They have also completed work on developing a model to quantify the impact of uncertainty in the biomass supply chain of the minimum fuel selling price in the conventional supply system. It will be interesting to see how the work develops as it moves forward. The project's relevance comes from its efforts to overcome barriers in financing, thereby, enabling the development of commercially viable bioenergy and bioproducts production facilities. It closely leverages expertise in the financial sector to guide the evaluation methodology for consistency with the finance industry's best practices. If successful, this project could help move projects forward and accelerate the build out of the bioeconomy.

The project is divided into two tasks. The first is to develop a framework to assess and integrate diverse risks and the second is to develop a stochastic techno-economic model to quantify the cost risk. While I understand the focus on standardizing risk in the biomass supply chain, this is not the only risk these first-of-a-kind plants encounter. Why limit this to the feedstock supply? Why not look at biorefinery risk as well? Also, the project plans to use stochastic techno-economic modeling to quantify cost risk.

But what about technology and market risks? Policy risks could also play a significant role and should be added to the analysis even if they are limited to the field to biorefinery portion. Because some risks are more qualitative than quantitative, it will be difficult to come up with an overall risk. Some method for weighting will be required and, since weighting is always subjective, will vary from person to person. How does the project plan to overcome this obstacle?

- The project's two tasks seem to be a reasonable approach to address the stated project objectives, addressing both a stated need for an evaluative framework and the development of a tool for addressing one critical portion of supply chain risk. I also appreciated the discussion of general contingencies for project developments (e.g., adjustment of framework based on feedback). In future work, I challenge the project team to provide greater detail on stakeholder outreach given the critical nature of buy-in and adoption of the project's resulting standards and certification framework.
- There are a number of sources of uncertainty and the success of this project will ultimately depend on whether the researchers are able to address enough of those sources to inform decision- and policy-making usefully. A critical distinction is between "garden variety" uncertainty (e.g., what is the outcome going to be?) and somewhat more esoteric notions. Not knowing what's going to happen is not necessarily a source of a market failure that will prevent investment that ought otherwise to occur. What is more problematic is when one party knows more than another (e.g., the "asymmetric information problem") or when no one knows the probability density function (sometimes called "Knightian uncertainty"). The project will be most useful if it can address these problems by expanding its focus to a wider array of risks (e.g., climate, market, and policy), as well as thinking about how technical (ex-

tent of market) and institutional (forms of contract) considerations might mitigate them.

- This project outlines a substantial amount of future work. There is a lot to be learned but it isn't clear that data are or will become available to support these modeling efforts.
- The project seeks to address financing barriers to biomass production by developing a framework for quantitatively assessing biomass supply chain investment risks. The project is targeting BETO's goal of aiding the commercial development of bioenergy pathways by catalyzing investments in biomass supply chains by facilitating risk assessment. This is an innovative and very practical, targeted undertaking. Given this clear focus, however, to maximize chances of success, stakeholder outreach to the targeted financial sector audience is essential to determine if the quantification of these risks will truly unlock supply chain investments, as well as to determine what type of analysis will be most helpful.

From a technical standpoint, it would be helpful if the project developed a fuller list and categorization of the relevant risks and uncertainties, mapped out to who bears the risk and in what context, as well as a discussion of which are unique to biomass versus other agricultural supply chain investments. Also, to the extent there are important risks not addressed by the project, such as biomass policy developments, for example, these should be identified and potentially alternative scenarios considered. Finally, it is important to know which risks are correlated or uncorrelated over space and over time. This would allow diversification over a portfolio of investments as well as understand opportunities for learning and adjustment over time.

- This project addresses the issue of improving understanding of investment risk associated with biofuel systems through creating supply chain risk estimates using distributions for key parameters and Monte

Carlo Analysis. The project is engaging finance industry stakeholders to help ensure its relevance.

The presentation does not make clear the interaction with the other groups working on TEA and LCA. The flow of data across DOE-funded projects should be made clear. Where is this project performing new TEA and where is it incorporating information already available? Where is it building on existing TEA studies? How are incorporating environmental and policy risks associated with biofuels? How is it incorporating uncertainty in global market conditions? Will the effects of developments in other energy technologies be considered?

The scope of this project, from feedstock production through to intake at the refinery is only part of the scope that would be considered in an investment decision. It would be helpful to connect with other TEA to provide a more complete picture of the overall costs and risks associated with biofuel pathways. While the scope of this project is limited to biofuel feedstock logistics, it would be helpful to frame results using the work of others to characterize other portions of the full biofuel life cycle cost.

There is a disconnect between the content of the presentation which would indicate the project is in the initial stages while the quad chart states it is 35% complete. If the project is 35% complete, the results are not well presented in the PPT slides.

Because the intent is to influence the financial industry, the project metrics for success should include critical feedback from the finance industry and examples of how the metrics/results calculated here are being used by finance industry stakeholders.

The benefit of this project is that it would "grease the wheels" of investment in bioenergy systems. This is relevant, but it should be carefully considered whether the state of biofuel technologies is such that this is the most significant question to be addressed. For example, if the project is providing

information for systems that are on the verge of commercial viability and it stimulates investment, it would be well worthwhile. However, if the systems analyzed are not ready for investment or if further TEA and LCA reveal other systems to be preferable to those considered here, the effort would not be very impactful.

The goal of creating a metric for biofuel investment risk is a good one and could really move the field forward. The presentation did not provide details on how this would be accomplished. Calculating risks for biofuel systems is a good first step, but there is much more work to be done to get consensus around an index and to engage stakeholders who would produce the data for the metric moving forward and others who would use it in investment decisions.

The case for the project would be stronger if Ecostrat or Stern Brothers were sharing in the project cost.

The future work for this project should include effort devoted to engaging additional stakeholders, establishing a project steering committee that periodically reviews project progress, next steps, and future plans, and establishing connections with other research groups in BETO and national laboratories, USDA, and EPA with the goal of taking advantage of results of other studies and feeding into ongoing/planned work elsewhere.

PI Response to Reviewer Comments

- Extend risk standards and certification framework beyond feedstocks into conversion. An overarching theme emerges from the reviewer comments; the risk standards and certification framework is as important to conversion as it is to feedstocks and should therefore be extended to conversion. Project researchers agree with this and recognize the need to extend the framework to conversion. However, the focus of the effort is deliberately on feedstocks

because of the barrier that risk in feedstock present to the emerging biofuels industry. Lack of clarity about the level of risk in biomass supply is a key factor limiting the scale and pace of bioenergy project development in the United States. The lack of tools and methodologies for quantifying biomass supply chain risk means that capital providers in the North American investment communities either overprice or underprice biomass project risk or refuse to price it at all. The result is that bioenergy project risk ratings tend to be high (many are pushed in to junk bond ratings territory), which makes most projects difficult or impossible to finance. The bottom line is that only a very small fraction of bioenergy projects that are proposed bioenergy projects are actually built. While concerns about technology, construction, and offtake have clear paths to resolution, at the present time there is no established way to quantify, discuss, and understand biomass supply chain risk.

As it pertains to biomass feedstocks, the industry is in its infancy. That is to say, while the means of evaluating the risks for technology, construction, and offtake are well established and understood, the risks around biomass supply chains are not. It is precisely this lack of clarity that has stopped many bioenergy projects that would otherwise be built and running today. Stern Brothers and Co., the nation's leading investment bank facilitating project financing for the renewable energy industry, confirms that this is a key challenge inhibiting bioenergy industry expansion. The bank's clientele includes many of the advanced biofuel production companies who have applied for and secured commitments for guaranteed loans from USDA for commercial plant build-out in the last two years including: ZeaChem Inc., Chemtex International, Fulcrum Bioenergy, Enerkem Inc., and Fibright LLC. Less unknowns exist for conversion than for feedstocks. Conversion technology and biorefinery operational risk is not unlike other chemical processing facilities.

Researchers acknowledge operational risks as an important area for analysis and maintain it as an area for future research.

Deploy risk standards and certification framework into the marketplace. The reviewer comments underscore the importance for project researchers to engage with industry and deploy the framework into the marketplace. Project researchers concur with this recommendation-- the project plan calls for significant industry engagement including partnering, advising, and collaboration. Ecostrat, a project partner and significant cost share contributor, has been involved in many renewable energy projects, assessing project financing, risk, and conducting

other analyses. Ecostrat collaborator Stern Brothers and Co. has joined the project as a partner, too. Leveraging these partners and other contacts in industry risk assessment, project researchers have created an Advisory Board to guide project development consistent with financial sector best practices. As the project matures, engagement with stakeholders in industry and the financial sector will continue to increase.

Project researchers are keen to keep in close touch with marketplace stakeholders so that analysts and others in industry and the financial sector will have confidence to use the risk standards and certification framework.

BIOPRODUCTS TRANSITION SYSTEM DYNAMICS

(WBS #: 4.1.2.31)

Project Description

The Bioproducts Transition System Dynamics project uses data and expertise from BETO-funded tasks to develop an analysis capability that enables a deeper understanding of early-market transition dynamics in the bioproducts industry. We will develop a transparent, analytic system dynamics model that tracks transition dynamics for several chemicals from biomass that satisfy either niche or scalable markets that are developed through economic and/or policy-driven mechanisms. The project will explore the influence of investor decision making, techno-economics, and market factors on these dynamics and will capture the role of investors and R&D dynamics in overcoming barriers. It will also explore the conditions under which synergies between

Recipient:	National Renewable Energy Laboratory
Principal Investigator:	Mary Bidy
Project Dates:	10/1/2016–9/31/2017
Project Category:	New
Project Type:	Annual Operating Plan
DOE Funding FY 2014:	\$0
DOE Funding FY 2015:	\$0
DOE Funding FY 2016:	\$0
DOE Funding FY 2017:	\$200,000

bioproducts and biofuels can both assist biofuels and enable a more robust transition to a bioeconomy. Key questions to be answered include how investor decision-making interacts with market and other factors to impact the bioproducts industry development, the extent to which such factors and development are predictable, and how data and knowledge gaps impact the results. Our goal is to demonstrate the analysis approach, provide insight into the bioproducts industry, and identify gaps in understanding, with an initial focus on bio-

Weighted Project Score: 7.8

Weighting: Approach–25%; Relevance–25%; Future Work–50%.

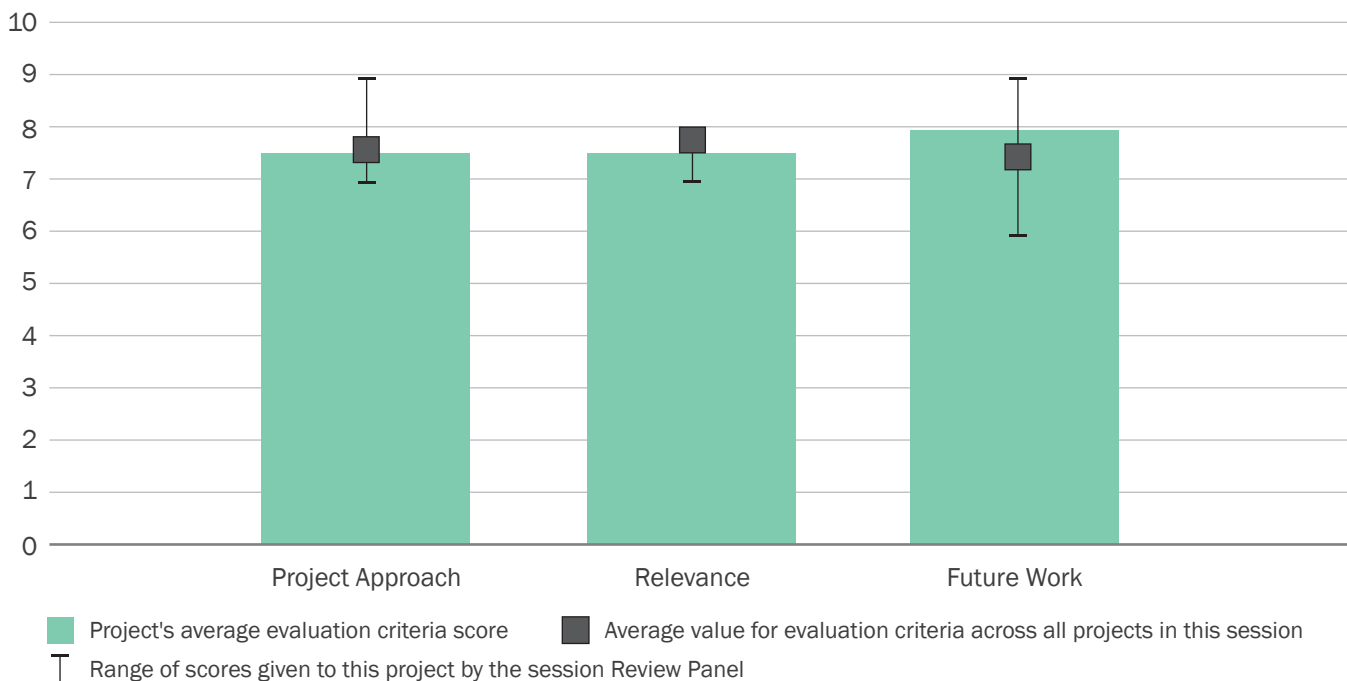

products with existing markets. Work in out years will focus on further engagement with industry and other stakeholders to evaluate bioproducts which have not yet entered the marketplace.

Overall Impressions

- BETO is interested in developing a broad understanding of conversion processes that produce bioproducts and possible scenarios for successfully advancing the bioproducts and biofuels industries. Therefore, this project seeks to develop an analysis tool capable of understanding the drivers that impact the growth of the bioproducts industry. This project builds on existing BETO work and connecting with other established BETO models will be important. Not only is it important to make sure that this project uses the data produced by other projects but that the information generated in this project can be, in turn, used to further other BETO work as well. The project appears to be well managed with frequent communication, clearly defined goals, and achievable milestones. It is great to see that collaboration and integration of data from ongoing projects as well as interaction with key stakeholders are part of the management approach. However, there are several projects working in closely related aspects of this work. Care should be taken not to duplicate efforts. This work will lay the foundation for exploring possible future scenarios and the connections between bioproducts and biofuels using a transparent SD model in an effort to better understand the technical and market synergies with biofuels. The emphasis will be on creating a flexible SD modeling framework to analyze the behavior of complex real world feedback systems over time. This is not easy and careful validation of the model will be needed. If successful, the project should provide critical insights and deep understanding of the complex factors involved in bioproducts production and market introduction as well as inform strategies and policies.

The team has outlined future work including developing the model and have already chosen six biobased chemicals for initial study based on several characteristics. One potential challenge with a project of this size is the ability to identify a few selective materials to begin the work that are representative of the sector as a whole. Having enough information available is critical, but these materials should also be broadly relevant to the overall work. I would suggest, in addition to the materials already down-selected, to focus on intermediates that could be further processed into a suite of products as well as platform chemicals that can be further upgraded for multiple high-value uses. It will also be necessary to focus on bioproducts that can be produced cost competitively with their fossil counterparts. It has been my experience that there is no real green premium. This also gets to the question of drop-in applications and materials with enhanced functionality. Drop-ins have an advantage when it comes to certification and validation in existing applications. However, enhance functionality provides value which can often offset increased cost. It is also important to consider the end users when looking at risk and competitive scale. Because this is an evolving market, technology breakthroughs in one area could positively impact the production of bioproducts elsewhere. For example, developments in shared feedstock handling could facilitate developments in other systems. Finally, this work appears to be policy oriented. Are there policies such as innovation incentives that could rapidly move this space forward?

- My only reservation is one of potential duplication with other efforts in the BETO portfolio. Responses from the presenter were helpful in acknowledging that crossover and/or synergies were recognized. Some level of system redundancy is helpful, so this is not a lingering concern of mine.

- My concerns with the project have largely to do with the limitations of SD as a method. Results depend on the specification of the equations driving them and it's not entirely clear to me what the empirical and/or logical basis for such specifications is. One must be careful not to extrapolate relationships which are reasonable approximations to local dynamics to the point where they generate a reduction ad absurdum. It is not clear to me how the calibration of the modeling effort here will avoid such a possibility.
- This project addresses an important question of how bioenergy and bioproducts markets are likely to evolve in their early stages. Nevertheless, the verdict is out on how useful this SD modeling approach can be. It will be important to ensure the model draws on data from other projects as much as possible and also to prioritize the stakeholder engagement component. This can perhaps be one of the most valuable parts of the exercise including perhaps conducting some detailed case studies that can provide qualitative insights alongside the quantitative analysis.

This seems like an interesting, flexible and potentially powerful addition to the toolbox for analyzing strategic policy and investment questions on bio-product and biofuel development. If successful, the model could be applied to a range of other questions. The verdict is still out on the insights that can be derived, but the interactions with stakeholders should be fruitful. It will be important to focus on the most actionable questions where the model can truly be used to test hypotheses, rather than build in the answer with an assumed structure or parameters.

- This is an exploratory project with a strong team, well developed project plan, clear go/no go criteria, and a good chance of success. Moving forward, it would be helpful to more clearly articulate how the results will be used by stakeholders and to define what data will be developed as inputs to this project

and how they could be disseminated in order to add value in their own right.

PI Response to Reviewer Comments

- We appreciate the numerous helpful comments that the reviewers offered, and are grateful to the reviewers for their time, consideration, and support. This project strives to fill a current gap in the BETO modeling portfolio that is not being addressed in other projects. Specifically, the model seeks to develop a more thorough understanding of the investment decision-making process for early-stage bioproducts. This is being informed through learnings from stakeholder interviews, which have focused on the key components of the investment decision-making process and how they may be weighted differently for different products. Being able to model this process will enable great insights into, for example, where to focus policy and/or funding to achieve the greatest benefits to the emerging bioeconomy. This tool will help BETO better understand commercialization potential of products and could help alignment of R&D strategies and funds by BETO to support technologies with a higher probability to move to the market faster and grow the bioeconomy at a greater rate.

Even if data are unavailable, the insights gained from stakeholder interviews and exploring the interdependencies in the system will be valuable particularly as the industry evolves and more data become available. During future work, we plan to increase the different types of chemicals that will be explored including functional replacements, intermediates, and chemicals cost competitive with petroleum products. Some of these components will be explored in FY 2017. The set of biobased chemicals chosen for study are all intermediates, and include both functional and direct replacements for fossil-based chemicals. This type of exploration will illuminate the varying market structures

for these chemicals and help stakeholders examine investment strategies. We will also expand to look at potential leverage points such as policy, prices, or other investment drivers. These leverage points can be readily identified and compared through the proposed sensitivity analysis. For policymakers, these insights could point to areas where they should focus resources. For industry, these insights could help to identify opportunities for their business cases.

The SD modeling framework has proven its value over the last decade of its application to scenario analysis of the biomass-to-biofuel supply chain. We are acutely aware of the dangers of extrapolation, so the project has undertaken a calibration and confidence-building effort to model a historic success

and failure in the bioproducts industry, thus moving the future use of the model from the realm of extrapolation to that of safer interpolation. Additionally, the specification of SD equations and feedbacks will be reviewed by subject matter experts and modelers with expertise in SD and other frameworks.

We will continue coordination with existing BETO projects and participation in the Bioproducts Working Group to keep abreast of developments and to avoid any duplication of modeling efforts. In addition, we will continue to engage industry through one-on-one conversations and a planned workshop to gain their feedback on the direction of this research and their insights about the investment decision-making process.

LAND USE CHANGE DATA AND ANALYSIS

(WBS #: 4.1.2.40)

Project Description

The objective of this project is to develop a novel land cover change detection method, which can be used to rapidly estimate changes in land cover using very high temporal resolution (8–16 days) satellite data. LUC is dynamic in nature which cannot be captured by static datasets and leads to erroneous conclusions when used for sustainability analysis. With recent advances in computing it is possible to analyze massive amounts of big data to extract information from high volumes of multi-temporal satellite imagery. This is especially critical for identifying changes in vegetation which has a natural phenology depending on location and climate and can be impacted by natural (e.g., hurricanes and drought) and man-made phenomenon (e.g., fire and

Recipient:	Oak Ridge National Laboratory
Principal Investigator:	Nagendra Singh
Project Dates:	10/1/2010–9/30/2017
Project Category:	Ongoing
Project Type:	Annual Operating Plan
DOE Funding FY 2014:	\$200,000
DOE Funding FY 2015:	\$150,000
DOE Funding FY 2016:	\$225,000
DOE Funding FY 2017:	\$225,000

LUC due to bioenergy). This project aims to provide tools and datasets to accurately assess changes in land use and land cover for which consistent and reliable datasets are lacking. The ultimate goal of this project is to integrate the models into a monitoring and visualization framework where changes in land cover over a long time period can be analyzed and visualized in near-real time. This will provide BETO, researchers, and policymakers the ability to accurately identify areas

Weighted Project Score: 5.3

Weighting: For ongoing projects, there is equal weighting across all four evaluation criteria: Approach, Relevance, Accomplishments and Progress, and Future Work.

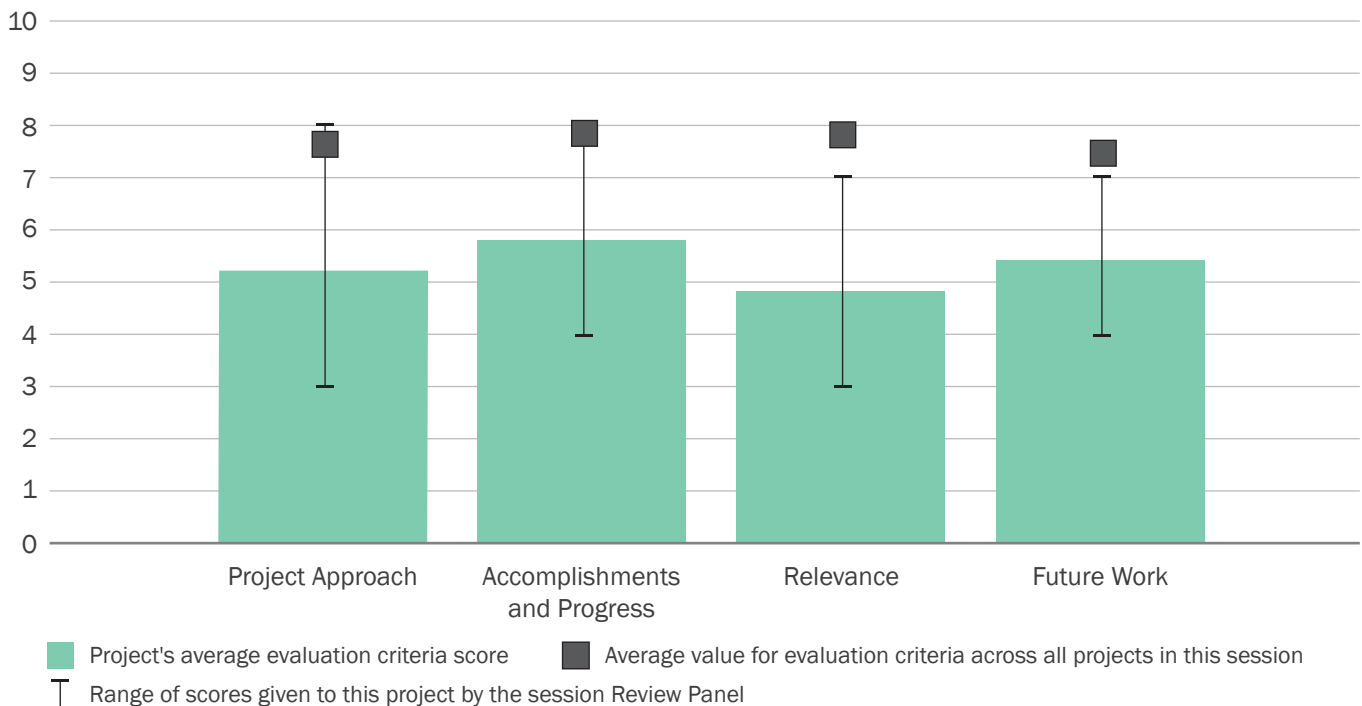

undergoing changes in land cover, yield, and biomass for analysis, planning, and mitigation purposes.

Overall Impressions

- This project aims to provide a suite of tools and datasets to accurately assess and visualize changes in land use in near-real time. It does so by applying novel classification and change detection techniques to time series satellite data to understand and characterize changes in land cover and use. The project team has regular meetings to discuss issues, tracks quarterly deliverables, and submits quarterly progress reports. Greater collaboration and integration with other BETO projects should be encouraged. For example, can the data produced by this model be used to validate existing LUC models? The project's technical accomplishments have been the development of a semi-supervised model that works with limited ground truth data and the development of a change detection platform for estimating and visualizing changes. While these are great accomplishments, I am concerned about the ability of the tool to be able to distinguish between plant types such as hardwoods versus softwoods or between energy crops such as switchgrass and miscanthus. Today, the resolution is not fine enough to characterize subtle changes in plant types. In other cases, the model can detect a change, but there is no way to attribute that change to biofuels or understand the causal relationship. So even if the model detects a change, there is no way to understand why there is a change. For the model to truly be effective, it must be able to monitor and measure subtle changes with time over relatively large regions. Being able to measure changes in the way land is used over time is a worthy goal and has real impact on the growing bioeconomy. However, the current state of development falls short of the stated goals. In addition, the most critical issue is to step back and ask who is going to use this tool. Is there a customer for this work, and how does this work integrate with other BETO activities? The researchers need to clearly define the linkage between this work and who will use it if it is going to be useful.
- All projects, not just this one, should have a clear link to the end customer (not just BETO) to understand the value the project will bring. Future work includes developing a model to forecast the expected land cover value at any given time based on past observations and to integrate climate, yield, and acreage data and other socio-economic data in the system to better understand drivers of LUC and management. The presenter also commented that the team was looking at incorporating policy into the tool. It is hard to visualize how this would be accomplished. At this point, focusing on more specific near-term technical milestones may be appropriate.
- The presenter stated that the goal is not to assess effects of bioenergy policy, but that is explicitly listed in the project goals section of the presentation. This needs to be resolved to fairly evaluate how this project meets/fails to achieve project objectives. At present, the work is essentially creating an LUC monitoring and visualizing tool, which is an interesting but crowded space. Attributing change to any particular driver is where the real value of the project lies in my personal opinion, but this aspect was not described in sufficient detail to allow for evaluation.
- The main issue with this project is that it is not clear what its intended contribution is. I am certainly impressed with the data analysis capability described. At the same time, however, I'm not sure how, or possibly even if, this will be helpful in achieving the larger goals of BETO.
- This project is pioneering cutting edge approaches to LUC detection with remote sensed data and could yield very valuable data products for LUC analyses and monitoring related to bioenergy. However, a weakness is that the project does not appear well

integrated with potential user demands. Better understanding the needs of potential users and perhaps piloting a test application could help ensure maximal impact in the remaining stages of the project. Similarly, the project should ensure coordination and integration with other existing LUC detection efforts, such as at the University of Maryland and the Brazilian Space Agency where similar methods are being developed and applied.

- It would be helpful for this project to take a step back and identify the key questions it is answering, identify stakeholders for those questions, gather stakeholder feedback on the usefulness of the project (e.g., through holding a workshop on LUC tracking), map the relationship to other satellite image analysis efforts, and clearly articulate how this project addresses a salient problem in a way that other ongoing work cannot.

PI Response to Reviewer Comments

- This project is an offshoot of an earlier project which focused on assessing gaps and uncertainties in existing data and models and developing a causal analysis framework for LUC. In FY 2015 the focus of this project transitioned to the development of an independent land cover change detection method using satellite data and a semi-supervised change detection model was developed based on the feedbacks of the 2015 Peer Review.

The objective of this project was to develop a land cover change detection method which can be used to rapidly estimate changes in land cover using very high temporal resolution (8-16 day) satellite

data. Our previous analysis has shown estimating land cover changes using derived data products has unacceptable amounts of uncertainty stemming from data aggregation and interpolation and time gaps in data production. With recent advances in computing it is possible to analyze massive amounts of data to extract information from high volumes of multi-temporal satellite imagery. This is especially critical for identifying changes in vegetation which has a natural phenology depending on location and climate and which can also be impacted by natural (e.g., hurricanes and drought) and man-made phenomenon (e.g., fire and LUC due to bioenergy). The goal of this project was to provide tools and datasets to accurately assess changes in land use and land cover as consistent and reliable datasets is lacking and not investigate the causal relationship between LUC and bioenergy growth as interpreted by most reviewers.

Using the developed algorithms and the causal analysis framework test case studies for various types of feedstock (i.e., crop, cellulosic, and pellets) and for various geographic locations can be investigated to determine the causal relationship between bioenergy and LUC as the next logical step in this project. Recent publications have correlated the reduction in grassland to the growth of biorefineries and reduction in forest cover in the Southeast due to the demand for wood pellet raising concerns about the environmental benefits and sustainability of bioenergy. An evidence-based analysis would provide a scientific basis for such concerns and help meet BETO's sustainability goals.

BIOFUELS NATIONAL STRATEGIC BENEFITS ANALYSIS

(WBS #: 4.1.2.41)

Project Description

This project helps DOE assess, quantify, and communicate the current and potential benefits of biofuels with an emphasis on energy security and fuel market outcomes. BETO funding started in FY 2012 building on prior ORNL work on alternative fuel transitions and energy security for DOE and EPA. A key impact expected from this project results from conveying to target audiences the multidimensional nature of the energy security concept as it relates to biofuels. Multiple energy security attributes (i.e., impact of biofuel on fuel price levels and volatility, and economic sustainability for supply chain participants) are explored using a suite of tools including a partial equilibrium model (BioTrans) to simulate market outcomes under a variety of scenar-

Recipient:	Oak Ridge National Laboratory
Principal Investigator:	Paul Leiby
Project Dates:	10/1/2011–9/30/2018
Project Category:	Ongoing
Project Type:	Annual Operating Plan
DOE Funding FY 2014:	\$300,000
DOE Funding FY 2015:	\$350,000
DOE Funding FY 2016:	\$200,000
DOE Funding FY 2017:	\$300,000

ios and econometric analysis of historical market data. Challenges include model benchmarking and validation and the adequate representation of shock dynamics and impacts, as well as consumer/producer expectations and behavior. Key outcomes in the FY 2015–FY 2017 cycle include the following: (1) BioTrans simulations show the mechanisms through which biofuels mitigate retail fuel price changes and costs during oil supply shocks, (2) updated estimates of the energy security premium of biofuels reveal a decline in the monopsony component

Weighted Project Score: 7.2

Weighting: For ongoing projects, there is equal weighting across all four evaluation criteria: Approach, Relevance, Accomplishments and Progress, and Future Work.

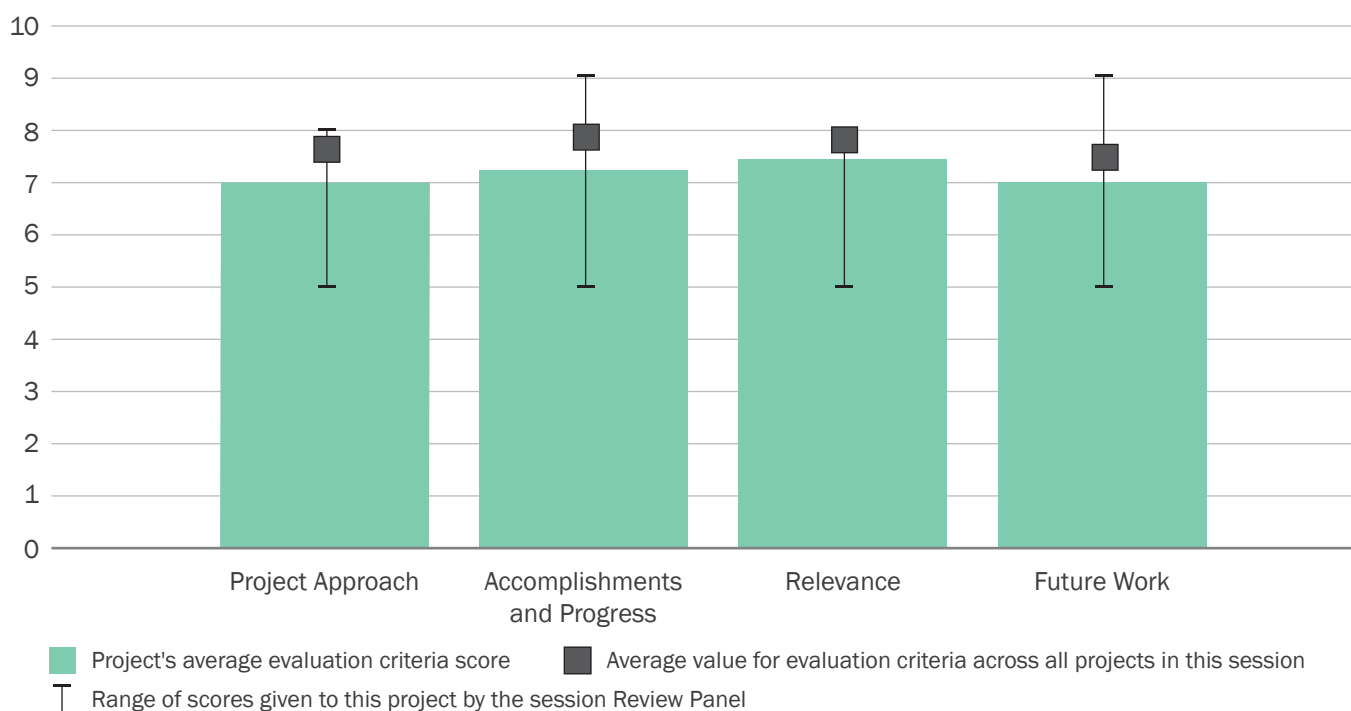

of the premium but continued value from reducing expected macroeconomic shock costs, and (3) estimation of the volatility dynamics of gasoline and ethanol indicate modest reductions in fuel price volatility through biofuel blending.

Overall Impressions

- The Biofuels National Strategic Benefits Analysis team seeks to assess, quantify, and communicate potential fuel market impacts, economic advantages, and security benefits associated with biofuels by combining equilibrium modeling of markets and policies with historical market data. The focus has been on the interactions between petroleum- and biofuel-based U.S. fuel supply chains. The project utilizes an interdisciplinary team and many of BETO's existing models. The project is well managed internally and with external partners through frequent communications and close collaboration. Of particular importance is the team's focus on validation using model comparison exercises, peer review, and benchmarking. Since the last Review, the team has provided a detailed exploration of the impacts of oil supply shocks under a variety of market contexts, updated energy security premium estimates associated with biofuels, and developed econometric estimations of the relationship between volatility of biofuel and petroleum fuel prices based on historical market data. I found it interesting that increased ethanol use could reduce volatility and mitigate price increases in gasoline. This group looks at the 'what if' scenarios. This type of work could be very helpful to the Co-Optima team as they move forward with the rollout of various blendstocks. Being able to better understand, measure, and communicate the economic impacts as well as the social benefits or risks of greater biofuel use under various market and policy scenarios is very beneficial and could help to provide insight on strategies to effectively achieve an economically sustainable advanced biofuels industry. This is huge, and again an enabler for the Co-Optima project, in understanding the role and implications of biofuels in changing market contexts to help guide strategic planning. In the future, the team plans to look at biomass supply shocks since, while biofuels help mitigate the costs of oil, the biomass feedstocks used to produce biofuels are subject to shocks of their own due to drought and other factors. One thing I would encourage the team to look at is the impact of biobased chemicals and bioproducts. We are seeing an increase in the production of these materials which could spill over into the biofuels space and serve to reduce the volatility of the system. One example of this is the ability of the Brazilian sugarcane plants to shift between sugar and ethanol production mitigating the price swings of both.
- This is interesting work. A small point, but I challenge the team to question if the "selected empirical analyses" are the most appropriate to address the broader project mission. I also would find utility in increased communication/integration with other BETO efforts; this project seems relatively unique in the questions it seeks to answer, so the question is how best to inform other efforts.
- This is an interesting and useful project to include in the BETO portfolio. In order to make it as useful as possible, it would be good to be more explicit about the welfare gains achieved by reductions in uncertainty. Consumers and producers may have different attitudes to price uncertainty, just as they have to price levels, and these might be the subject of further analysis. One of the more compelling arguments for biofuel development may be as a sort of hedge against uncertainty in the supply (and, hence, prices) of other energy sources, and it might be useful to consider how this would be expressed, perhaps via a real options approach (or equivalently?) in terms of its "beta" with other investments.

- This is one of the more valuable and innovative projects in terms of building the base of evidence for the rigorous evaluation of bioenergy economic and security benefits. The empirical, econometric focus is important.

In addition to forward-looking modeling of alternative scenarios, the project might also estimate the value of historic policies retrospectively.

It would be valuable to contextualize the role of biofuels in terms of energy security benefits with a comparison with other potential measures to achieve similar goals including the strategic petroleum reserve, energy efficiency measures, and other types of non-fossil energy diversification.

- The presentation includes responses to comments from the 2015 Peer Review. These two comments are particularly relevant and it is urgent that they are addressed in the near-term for the project to be relevant and impactful.

2015 Comment: “I don’t see how the work is being related to the public policy space/is making impacts, particularly if the publications/deliverables are not available online.”

PI Response: We will make it a priority that our work becomes more visible and clearly linked to issues facing decision makers in the policy space. For future work, we have proposed more of an outreach effort, including a visible website area and/or a workshop highlighting our results and related work by others, as well as the pursuit of high-visibility external publications. One major goal is to show how volatility and shocks influence the economic and social benefits of biofuels and to inform the research and policy community on how resilience strategies can enhance those benefits.

A Google search for BioTrans ORNL yields only the 2015 Peer Review presentation. A Google Scholar search does not yield any relevant hits.

2015 Comment: “There would be much value in seeing planned future work integrated with the results of work to date in an interim report. The project appears to be developing numerous sub-analyses of the fuels and bioenergy market. However, the material and conclusions need to be periodically tied-up together so broader themes are easier to follow.”

PI Response: We acknowledge the need to better tie up together the results and insights from the various tasks and modeling approaches we are using in this project. We have cited as one of our objectives for the future of the project to develop a website to host interim working papers and publications and to explain how all relate to the central topic of explaining and quantifying the economic and energy security benefits of biofuels.

It would appear that the publication cited in Slide 22 (Leiby, Paul N. and Rocio Uria-Martinez (2017) “Biofuels Blends and Fuel Price Volatility—A Portfolio Analysis,” ORNL Report, February.) addresses this comment, but the report does not appear to be publicly available.

For this project to have an impact, the results must be published, preferably in peer-reviewed journals.

PI Response to Reviewer Comments

- The reviewers strongly recommend focusing on communicating our results, through peer-reviewed publications, discussions with stakeholders, and “increased communication/integration with other BETO efforts.” These are all important, and we are making these communications a high priority this fiscal year. The FY 2017 work plan has a decided focus on result dissemination. We recently submitted a paper analyzing the role of biofuels in response to oil supply shocks to a peer-reviewed journal. We are working to also submit the econometric analysis of biofuel effects on fuel price volatility. In

addition, our FY 2017 Q4 milestone consists of two deliverables: (1) the release of a web interactive tool in which users will be able to explore results of BioTrans scenario simulations and empirical analysis, and (2) a companion paper summarizing insights from the simulation of oil supply and biomass supply shocks. We have adopted an efficient strategy to implementing this web tool (using RStudio/RShiny). We will share a beta version of the web interactive tool with other researchers and industry stakeholders to receive feedback on results and the user experience to ensure the content presented is useful for the targeted audiences.

In terms of interactions with other BETO researchers, the reviewers note “Of particular importance is the team’s focus on validation using model comparison exercises, peer review, and benchmarking.” We have done paired model comparisons with BSM, are participating in the BETO Model and Tool Mapping project, the BETO Bioenergy Modeling Workshops, and will be BSM Beta Testers (focusing on comparing model behaviors and identifying opportunities to propose BSM extensions with insights or approaches from BioTrans).

In addition, we will reach out to other BETO teams to exchange insights and approaches that may advance our collective efforts. One prime example is to see how we can, as the reviewers suggest, “be ... helpful to the Co-Optima team as they move forward with the rollout of various blendstocks.” We do think BioTrans, and the supporting empirical analyses related to fuel price volatility, can help BETO and Co-Optima team understand and measure economic impacts and benefits/ risk. We can also use the BioTrans model to evaluate the economic benefits of some of the biofuel system engineering

designs being analyzed by others, such as flexible multi-feedstock biorefineries, advanced biomass logistics systems, and bio-co-products techno-engineering analyses design configurations. Each of these could help diminish or diversify risk and provide benefits. As the reviewers indicate, biobased chemicals and bioproducts will likely have economic impacts that spill over to biofuels, and could alter the volatility of prices and diversify the risks to biofuel supply chain participants. We have identified this as a prime candidate for follow-on research. Finally, we can offer the biofuels energy security premium calculation as a \$/gallon metric that can be used by other projects to incorporate expected energy security benefits.

The reviewers have suggested a number of promising areas for further application of our work, and for extensions. One commenter notes that, “In order to make it as useful as possible, it would be good to be more explicit about the welfare gains achieved by reductions in uncertainty.” We agree that changes in uncertainty and volatility can be influential and valuable, and we need to extend the current welfare measure to account for that. We are also looking at other energy security measures and real options theory.

In summary, we gratefully accept the cautionary comments and the recommendations that we stay focused on maximizing the impact of our work through carefully focused research efforts, communications, and peer-reviewed scientific output. We are excited about the ideas for further research. We are also very encouraged and appreciative of the comments regarding the value and innovativeness of our project.

BIOECONOMY ANALYSIS

(WBS #: 4.1.2.42)

Project Description

The bioeconomy vision projects an increase in biomass utilization to three times the current level, with bioproducts contributing up to 50 billion pounds of output by 2030. However, the path to achieving this vision is not well understood from current analyses. Questions such as price sensitivity of particular chemicals, the number of new facilities, and maximizing the value of biomass under a dynamic market remain critical to technology commercialization success. The project’s main objectives are threefold to provide DOE and technology stakeholders with a quantitative economic assessment of (1) the determinants of demand in the bioeconomy; (2) interactions among biofuels, biopower, bioproducts, and fossil products; and (3) the economic sustainability of the U.S. biofuel industry through integrated modeling using TEA, LCA, and market data. Although market

Recipient:	Oak Ridge National Laboratory
Principal Investigator:	Laurence Eaton
Project Dates:	10/1/2016–9/30/2019
Project Category:	New
Project Type:	Annual Operating Plan
DOE Funding FY 2014:	\$0
DOE Funding FY 2015:	\$0
DOE Funding FY 2016:	\$250,000
DOE Funding FY 2017:	\$250,000

interactions are expected to induce a combination of important negative and positive impacts on the biofuel industry, the net effects can only be understood through formal quantitative economic analyses. This information is critical to support policies and R&D efforts to help meet the strategic goal of maximizing the economic, environmental and social benefits of biomass to the U.S. economy (2016 *Multi-Year Program Plan*). The project will use findings from the recent interagency Bioeconomy Analysis and laboratory market analyses as

Weighted Project Score: 6.0

Weighting: Approach–25%; Relevance–25%; Future Work–50%.

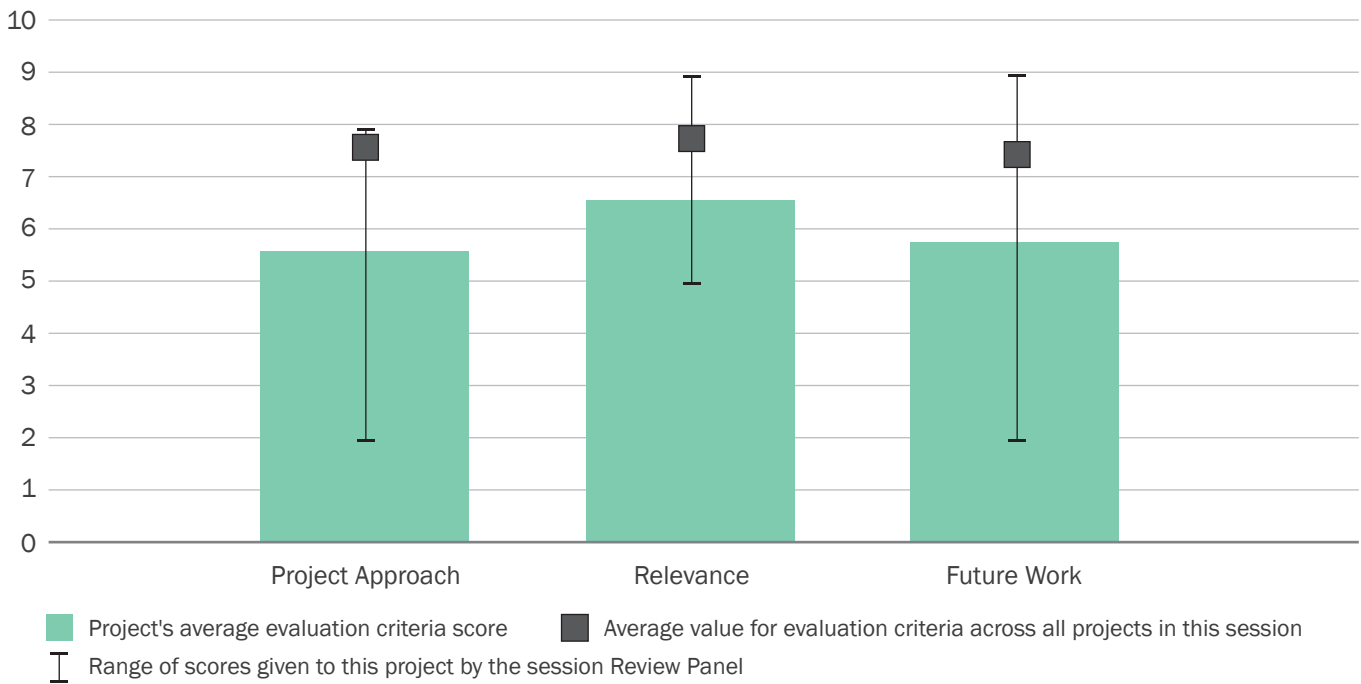

the starting point to examine the economic case for the bioeconomy vision.

Overall Impressions

- This project explores the economic ramifications of various strategies in developing the bioeconomy and seeks to understand the economic, social, and environmental implications. As a new project, the team hopes to design and develop novel economic approaches and tools to identify and measure the interactions among biofuels, biopower, and bioproducts along with conventional fossil products through integrated modeling using TEA, LCA, and market data. It is an interagency effort led by BETO and is comprised of a team with expertise in energy and agricultural economics. Collaboration and communication will be key in achieving maximum value from this project. The outcome of this project is to provide BETO and decision makers with price and economic impact tools needed to determine the best use of biomass resources as well as the demand drivers and sustainable commercialization pathways needed to expand the bioeconomy. The team will use economic principles combined with techno-economic and market data to explore feasible bioeconomy alternatives. The strength of this project is in its desire to answer critical questions around the marketing of bioproducts as well as looking at the role of bioproducts in advancing biofuels. These are worthy goals and much needs to be done in this area. However, I would caution the team against reinventing the wheel and taking advantage of the information already generated by other BETO projects because this project, on the surface, appears to overlap with other projects. I would ensure the work is focused on the gaps in BETO's understanding. Future work includes updating empirical data on fossil and biobased products including market size and structure, costs, and technologies that are most relevant to the biofuel industry; estimating the

impacts of bioproducts on the competitiveness of advanced biofuel technologies including the cost of meeting the biofuel policy targets; and stimulating the economy-wide impacts of bioproducts.

Most of the work outlined by the team deals with the interactions between bioproducts and biofuels. I was confused about what the team proposed to do in regard to the interaction with biopower and urge the team to carefully consider the boundaries of the study (e.g., do you consider biomass pellets to Europe?). Developing specific goals and engaging with stakeholders will help to focus the project. Understanding the impacts of regulation will also be essential. I would urge the team to build on the work already done at CEMAC as well as BIC best uses of biomass tool developed in a former NREL study. Finally, understanding how to maximize the market opportunities for bioproducts alone will ultimately spill over into the biofuels space. Therefore, I see task 4, the evaluation of the potential penetration of bioproducts under alternative future market scenarios and analysis of cascading supply chains for biobased products, as key.

- The objectives and high-level approaches seem reasonable. It is difficult to judge the absolute appropriateness of the methodology given the lack of details available at this point.
- This project describes an ambitious agenda for economic modeling of the development of bioproducts. More details need to be filled in, however, in order to understand how this is to be done and how the results may be useful. It would be helpful to have clear criteria established to grade the interim achievements of the project. In this regard, it's important not only that the models developed be able to explain certain sets of data (this can always be done by creating sufficiently complex parameterizations), but also to predict outside of the data to which the models are calibrated.

- This project seems very well positioned to make an important contribution to analyze the bioeconomy potential market and environmental benefits and possible trade-offs. It should provide valuable inputs to developing an evidence-based strategy, helping to motivate other projects by providing the bigger picture as to how bioproducts fit into a strategic approach. It would be important to ensure this project draws as much as possible on other findings and projects. It will also be important to make sure that environmental as well as economic considerations are central.
- This project should undergo a round of planning focused on establishing clear milestones that can be accomplished on a quarterly/annual basis, identifying datasets and relationships to other efforts to allow for efficient project execution, and establishing a plan for managing project risks.

A useful first step for this project would be to prepare datasets detailing factors involved in the price of conventional fuels and chemicals, biofuels and biochemicals, and other new fuel and chemical pathways likely to enter the marketplace in the near term. These data could play an important role as inputs to other models.

This project should not have produced a tool as an aspiration until it has prepared data, done case studies, established an analysis framework, engaged and understood the needs of stakeholders, and more generally proven its worth.

PI Response to Reviewer Comments

- Thank you for these comments. Acknowledging the breadth and depth of the bioeconomy, with previously disparate industries now paired together, it is a challenge to model everything simultaneously. While the focus of BETO has shifted toward bioproducts with biofuels, a larger vantage is required to consider the multiple input and output markets involved within the bioeconomy.

We agree with the surface-level appearance of overlap with existing projects in the BETO portfolio. It is likely that this impression was created by lack of emphasis in the presentation on how we intend to link this project with existing efforts through data and information gathering from existing BETO laboratory projects, such as CEMAC, strategic analysis, conversion, and ORNL feedstock analysis using an economic framework. It is this economic modeling and analysis approach detailed in additional responses below that will uniquely differentiate this project within the portfolio. Therefore, we hope to not reinvent but rather complement the analysis, both ending and ongoing, through synergies and collaboration.

Several analyses have focused on the potential to expand the bioeconomy, but have lacked rigor in detailing the price interactions of markets, demand determinants, and the potential limits to expanding small and dynamic sectors, such as chemicals from biomass. The economic modeling tasks, therefore, are focused on four main areas: (1) collection of detailed time series data of bioeconomy market segments (building upon findings from previous projects); (2) market demand analysis (elasticities within and between markets) and supply analysis from BT16 and other analyses with conversion TEA information; (3) use a partial-equilibrium market framework to evaluate how policy, market, and other factors determine the bioeconomy outcome, accounting for cross-sector relationships; and 4) simulate biomass benefits nationally within an input-output modeling framework.

The initial tasks are to develop datasets of information of the bioeconomy and new chemical pathways based on BETO analysis. It is noted that this information changes due to market dynamics and interest from BETO's perspective, so frequent revisiting will be required to ensure data for modeling are current and reflect state of industry and conversion science.

Biopower and pellets are of interest as potential sources of feedstock competition for new industrial uses. The purpose of including these would be to identify and account for changes in demand for existing and new biomass as projected by DOE's Energy Information Administration and other forecasting groups.

USDA has noted that the limiting factor of bioeconomy expansion is the availability of feedstocks, for which production may have significant environmental impacts.

The statement about caution toward developing a tool at the infancy of a project is wise and will be considered. This output was identified when the

project took shape as a potential public output. However, the production of such a public tool will take place later in the life of the project after several iterations of data collection and modeling. The steps to create a public model would be deliberate, peer reviewed, and vetted with stakeholders through user testing. This will be considered in the revisiting of the project plan and outputs.

We have identified and are in communication with relevant BETO-funded projects including INL's work on pellet market analysis. We recognize the role of regulation for biofuels and that it is likely to be crucial for bioproducts, thus making this part of our project's efforts.

GCAM BIOENERGY AND LAND USE MODELING AND DIRECTED R&D

(WBS #: 4.1.2.50)

Project Description

This project provides global modeling and analysis of bioenergy questions using the PNNL Global Change Assessment Model (GCAM). This project is relevant to BETO's A&S Technology Area as it analyzes bioenergy in the integrated context of global energy and agriculture. The GCAM project is an established, multi-client effort ongoing for over two decades. GCAM is widely used by DOE and EPA, participates in international analysis efforts such as the Intergovernmental Panel on Climate Change (IPCC) and Stanford Energy Modeling Forum, and is an open-source community model available to all. This BETO project leverages the GCAM

Recipient:	Pacific Northwest National Laboratory
Principal Investigator:	Marshall Wise
Project Dates:	10/1/2010–9/30/2018
Project Category:	Ongoing
Project Type:	Annual Operating Plan
DOE Funding FY 2014:	\$150,000
DOE Funding FY 2015:	\$150,000
DOE Funding FY 2016:	\$150,000
DOE Funding FY 2017:	\$150,000

program to focus on improving modeling capabilities, data, and analysis in key areas related to bioenergy production and use. Beginning in 2010, technical accomplishments include published analyses about lignocellulosic bioenergy crops, bioenergy technologies for liquid fuels and power, and bioenergy with carbon dioxide capture and storage. FY 2013 and 2014 focused on modeling water demand parameters for bioenergy produc-

Weighted Project Score: 8.0

Weighting: For ongoing projects, there is equal weighting across all four evaluation criteria: Approach, Relevance, Accomplishments and Progress, and Future Work.

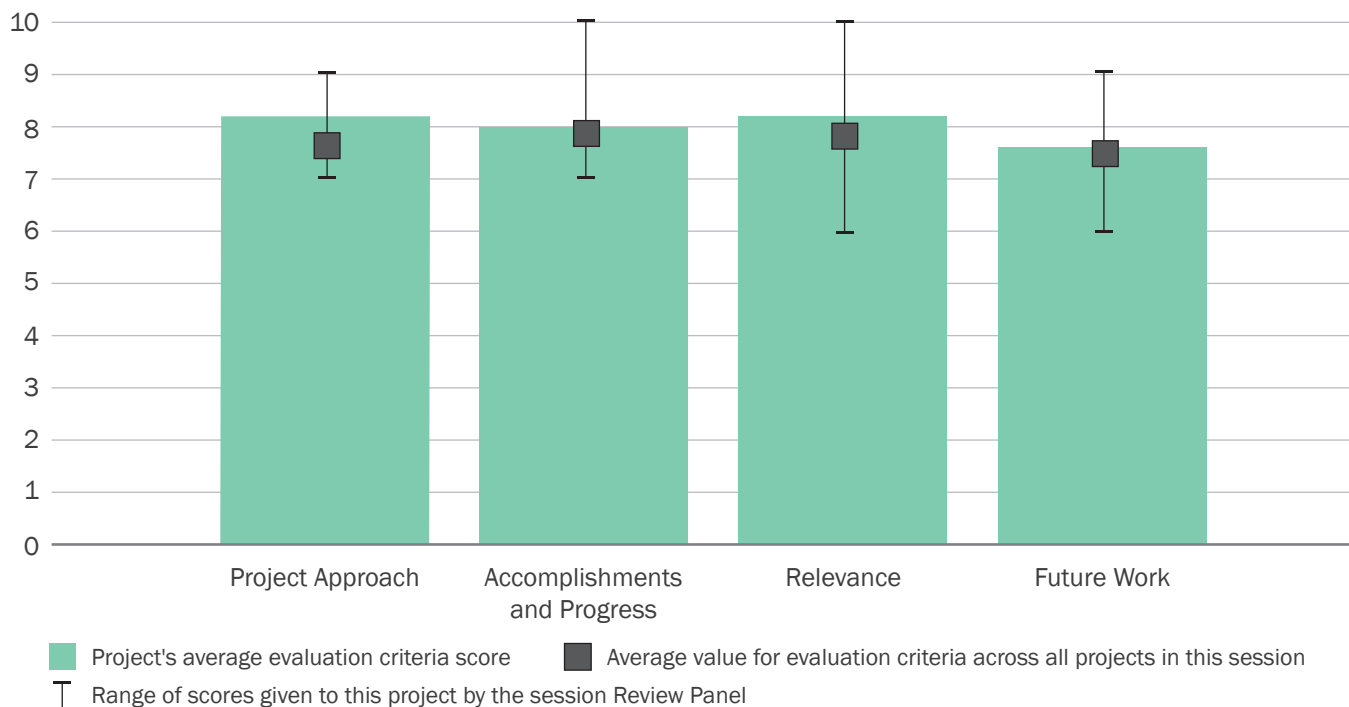

tion. For FY 2015 and 16, we analyzed the potential and impacts of large-scale production and use of biofuels for aviation and freight transport using the transportation demand sector of GCAM. Currently in FY 2017, we are studying the multi-sector, integrated potential and impact of bioenergy considering competing technologies across the energy system.

Overall Impressions

- The purpose of this project is to perform integrated analyses of bioenergy sources and technologies in a global modeling framework. Because this project serves a support function, it is critical to carefully define what key bioenergy A&S questions are going to be part of the analysis and model development efforts. The project appears to be well managed and is strongly leveraged internally with other BETO projects and externally across multiple agencies and several industrial partners. It is good to see the close collaboration, model vetting, and detailed documentation throughout the project. The aim of this activity is to provide timely, relevant bioenergy analyses through the continued development and maintenance of GCAM. Since the last review, GCAM focused on the energy sector by analyzing the potential scale and context for aviation biofuels as a way to reduce GHG emissions and the dependence on fossil fuels. The team also looked at the role of biofuels to meet a growing demand for on-road freight transportation. I found it interesting that when modeling global bioenergy potential, the team found that food crop yields were key. Getting developing countries to adopt the use of hybrid seeds and modern agriculture techniques would go a long way in supplying the global food supply and fuels. This project provides a long-term economic, multi-sector, policy, and international context for bioenergy considering energy, agriculture, and emissions. The work done on this project complements other BETO-sponsored tools and research. It is great that the analyses and model developments done as a part of this project are made publicly available. It is great to see that the model has been picked up and used in other studies. I also applaud the group for its continued efforts in validating the model since understanding the global ramification of the bioeconomy is a complex issue. Future work specifically includes looking jointly at bioenergy for power, gas, and liquid fuels for passenger and freight transportation as well as carbon capture, utilization, and storage. While the strength of the model is its ability to look at the larger global picture, it would be helpful to better understand how this model relates to other economic models such as those from the Food and Agricultural Policy Research Institute (FAPRI) and Global Trade Analysis Project (GTAP).
 - I do not have any concerns about this project, nor do I have any specific comments or suggestions to improve upon it. GCAM is widely used by a variety of users and for a variety of analyses. The connection to other BETO modeling efforts was noted and appreciated. Model management, updates, and analyses seem to be conducted in an open, transparent, and collaborative manner. Demonstrated use of the model by those unaffiliated with BETO is a strong indication of GCAM's relevance to a broader community.
 - I find this a very strong and appealing project for two reasons: (1) it leverages substantial investments already made in GCAM, an integrated climate assessment model and (2) it is part of a larger climate modeling effort, it allows "apples-to-apples" comparisons of alternative approaches to addressing climate change.
- In addition to these aspects, the possibility of integrated economic modeling to locate areas in which additional production of biomass might be situated, as well as areas to which food production might be displaced, may provide a useful modeling platform for predicting LUC.

- The project leverages the capabilities, recognition, and availability of GCAM. The main strength of the project is ensuring the capability of GCAM for answering bioenergy-related questions and having access to the modeling team for targeted requests. Ensuring relevance depends on the particular questions being asked that best maximize the value of the tool. For example, the most recent analysis on aviation addresses a timely topic but it is unclear that a single sector study fully leverages the GCAM platform. Deploying GCAM to answer the types of questions it is suited for or making it available more widely to take advantage of these capacities should be a priority for future work including the proposed passenger and freight and carbon capture and storage analyses. Displaying and sharing data and results via the Bioenergy KDF or BIC should also be considered.
- This is a data-intensive, complex model with significant maintenance requirements. BETO should decide whether to invest significantly in maintaining and developing this model for understanding LUC associated with biofuel systems. The model's financial health should also be considered in terms of other sources of funding.

Given the complexity of the model and the data requirements, it would be helpful to consider how it might be used beyond analysis of LUC. This project is very similar to the aspirational plans of the project led by PI Eaton. It would be helpful to manage these two projects together such that Eaton's work feeds in to GCAM and GCAM could be applied to answer questions posed by Eaton.

PI Response to Reviewer Comments

- Thank you to all the reviewers for your time and attention. These Peer Review efforts have been extremely valuable in helping to focus the scope of this project in the context of BETO.

We have worked with BETO to define the complementary roles of GCAM among its modeling tools. FAPRI, Forest and Agricultural Sector Optimization Model (FASOM), and GTAP are other prominent economic modeling efforts that consider bioenergy but also have broader user groups and audiences. FAPRI and FASOM are both valuable in that they can focus in detail on specific crop markets and forestry with much smaller regional resolution in the case of FASOM. GCAM incorporates less-detailed representations of these sectors in most instances, but it considers them in a dynamic global context that importantly includes the detailed energy system. GTAP is different in that it is a general equilibrium model covering the entire economy with a strong focus on near-term agriculture markets and trade. GCAM complements this by having a longer-term focus with more technology detail in the future energy system.

The suggested interaction with the bioeconomy analysis project is appreciated. We have used the bottom up detailed analysis in *BT16* (and the other two reports in the Billion-Ton series, the 2005 *Billion-Ton Study* and the 2011 *U.S. Billion-Ton Update*) to crosscheck the feasibility of bioenergy results we see in GCAM scenarios. We could provide a further link in the other direction by providing the potential scale and roles of bioenergy long-term and globally in the context overall energy and agriculture.

Finally, we should and will provide a link to GCAM and papers on the Bioenergy KDF.

IMPACT OF PROJECTED BIOFUEL PRODUCTION ON WATER USE AND WATER QUALITY

(WBS #: 4.2.1.10)

Project Description

This project develops an analytical framework and models to quantify the relationships between bioenergy production and water use, quality, and resource availability with spatial resolution; evaluates management practices in bioenergy landscapes that protect water resources and increase water use efficiency; and identifies scenarios that improve the water sustainability of advanced bioenergy systems. Outcomes of the project are geospatial analyses of national-scale and county-level water footprints of biofuels; a spatial-explicit model, WATER; an energy-water resource inventory; and a suite of multi-scale Soil and Water Assessment Tool (SWAT) hydrologic models. Since the 2015 Peer Review, this project (1) assessed the water footprint of six *BT16* scenarios for agriculture and

Recipient:	Argonne National Laboratory
Principal Investigator:	May Wu
Project Dates:	10/1/2010–9/30/2017
Project Category:	Ongoing
Project Type:	Annual Operating Plan
DOE Funding FY 2014:	\$650,000
DOE Funding FY 2015:	\$625,000
DOE Funding FY 2016:	\$725,000
DOE Funding FY 2017:	\$714,310

forestry, (2) developed a SWAT model for the Iowa River Basin and examined the effect of a *BT16* scenario that includes various conservation practices (i.e., cover crop, tile drain control, slow-release nitrogen fertilizer, and riparian buffer) on water quality, (3) developed a SWAT model for the Lower Mississippi River Basin, (4) analyzed the management of biorefinery wastewater for a biological sugar-to-hydrocarbon process, and (5) developed methodology for the representation of water availability. In addition, the PI became a member of the Hypoxia Task Force modeling group. Output from this project feeds directly

Weighted Project Score: 8.3

Weighting: For ongoing projects, there is equal weighting across all four evaluation criteria: Approach, Relevance, Accomplishments and Progress, and Future Work.

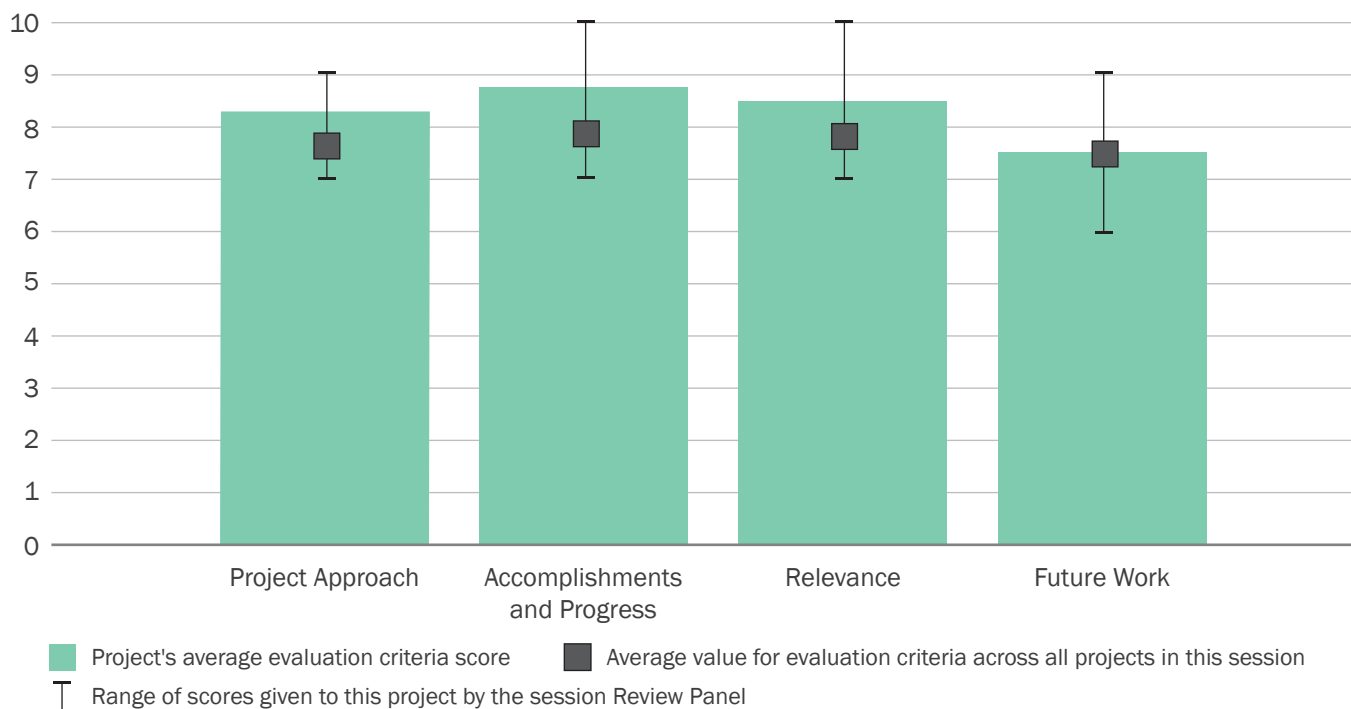

into biorefinery TEA/supply chain sustainability analysis and the development of sustainability indicators.

Overall Impressions

- The goal of this project is to establish quantitative metrics to identify and select water sustainable scenarios in the production of bioenergy and bioproducts. The project goes beyond looking at just water consumption to also look at the broader metrics of water quality and availability. This is important as many places here in the United States, as well as globally, face water shortages and other challenges. The project has a well-defined approach and encourages transparent analysis. The emphasis on collaboration is excellent and critical in obtaining the necessary data and stakeholder engagement. Having the WATER tool open access also adds to the transparency and rigorous validation of the model assumptions. The technical accomplishments of the project were extensive and included contributions to two chapters in the BT16 report as well as six BT16 agriculture and forest scenarios. This was a great way to highlight the hard work that has gone into producing this model and the current level of maturity in the analysis tools. The past two years have also seen the extension of the model to include best management practices for water quality improvements and the addition of new pathways in the WATER model. A key accomplishment since the 2015 review has been to look at the temporal and spatial variations in rainfall and water availability to meet energy crops and biomass production. This project provides the necessary framework to examine water sustainability metrics for biofuel and biomass production that goes beyond water consumption and looks at water quality and availability metrics. This will be critical as the bioeconomy grows. Future work will include the release of the water resource availability index for several agricultural and forestry scenarios as well as improved guidelines for biorefinery wastewater management options and treatment schemes. This will be very helpful in reducing water usage, improving biorefinery design, and mitigating costs associated with wastewater treatment. It was suggested in the 2015 Peer Review that algae because of its high-water use and ability to use gray and salty water would be a great addition to the model. When asked about looking at algal systems, Dr. Wu said that the technology is still immature at this time but that they have plans to look at it in the future. I would like to encourage BETO to do this since water is such an integral part of the algae system. It would complement BETO's ongoing work on algae and add a robustness to water modeling.
- The project appears to be progressing well. Project objectives, outcomes, and future efforts are all reasonable. Accomplishments thus far provide interesting insight into the primary research question. Stakeholder engagement is strong. Consideration should be given to better engaging (or documenting existing engagement with) non-public sector entities, such as private industry or nongovernmental organizations.
- One issue that is common to treatments of water quality projections for the bioeconomy concerns whether biomass crops will have different environmental effects than do existing crops. A number of measures might be taken to make growing biomass more environmentally benign, but similar measures might also be adopted to reduce runoff and other negative effects from existing crops. This really goes beyond the scope of this project per se, but it is important to consider more generally how BMPs that would enhance environmental performance might be implemented in the absence of regulatory drivers.
- Overall, this project is core to developing BETO's capacities on the water impact side. It would be helpful to explain how this project complements other water modeling efforts in government and aca-

demia for the same regions, as well as related work for other regions, and to think about how the results can best be disseminated and made useful to stakeholders particularly in terms of the planned water management guidelines.

It would also be valuable to use the model to compare the water impacts of energy scenarios with bioenergy vs. other energy alternatives.

PI Response to Reviewer Comments:

- The project team expresses its deep appreciation to the reviewers for their time, encouragement, and valuable input. We also thank the reviewers for recognizing our accomplishments and providing future directions. To broaden the reach of our research, we are working on a plan to disseminate data, communicate results, and

promote the tools developed as a result of this work to the scientific community and general public via various channels, including peer-reviewed journal publications, webinars, and other means of communication. Looking forward, as part of our project plan, we will consider adding an algae pathway to WATER and address the impacts of the non-bioenergy and electricity scenario on water resources. We will continue to work with other federal agencies and research institutes on modeling comparisons for the Mississippi River Basin and its tributaries and regional watersheds to address impacts on water quality. In addition to working with federal agencies, we will increase engagement with private sectors in biomass production and wastewater management. Finally, we will stay focused and continue our contributions to BETO, as well as to the development of the bioeconomy.

INTEGRATED LANDSCAPE MANAGEMENT

(WBS #: 4.2.1.20)

Project Description

Biomass supply systems solely dependent on agricultural residues are subject to strict limitations and risks in feedstock availability when soil health, offsite environmental impacts, uncertain growing conditions, and producer economics are considered. This project, started in FY 2015, is designed to increase overall biomass production, reduce grower losses, and improve soil and water quality. In FY 2017, another environmental component has been added to the project for the estimation of the reduction in nutrient loading to water bodies from wash off of nutrients from agricultural watersheds as a result of energy crop integration into the agricultural landscape. By utilizing subfield management and decision tools

Recipient:	Idaho National Laboratory
Principal Investigator:	Shyam Nair
Project Dates:	10/1/2006–9/30/2017
Project Category:	Ongoing
Project Type:	Annual Operating Plan
DOE Funding FY 2014:	\$300,000
DOE Funding FY 2015:	\$450,000
DOE Funding FY 2016:	\$450,000
DOE Funding FY 2017:	\$550,000

to integrate energy crops into the landscape, field-level profitability can be improved, annual biomass availability can be increased, and logistics costs can be brought down. The project has shown the feasibility of meeting the \$84/dry ton feedstock cost target and the potential to significantly increase biomass production by integrating energy crops into agricultural landscapes through analyses of four counties in the United States. Efforts are ongoing to expand the analysis to all relevant counties in

Weighted Project Score: 7.1

Weighting: For ongoing projects, there is equal weighting across all four evaluation criteria: Approach, Relevance, Accomplishments and Progress, and Future Work.

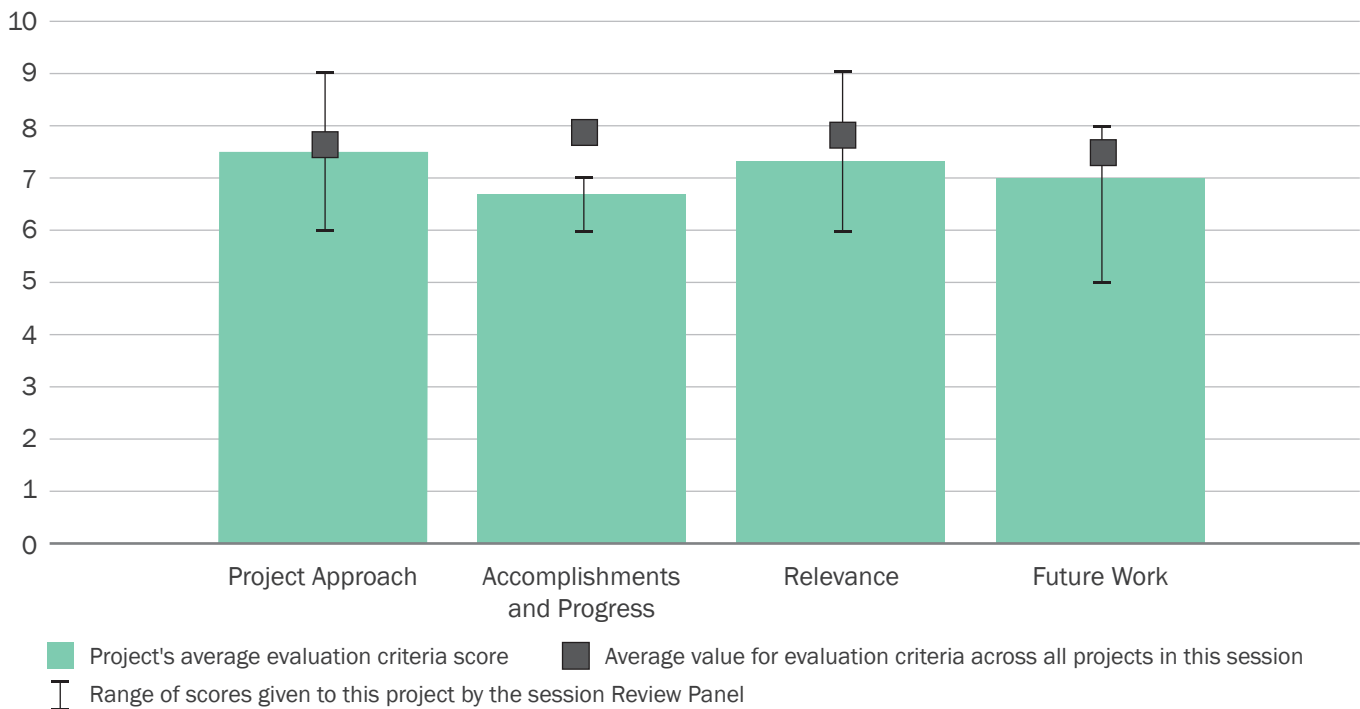

Kansas and Iowa and deploy the products of the analyses on the Internet. For the bioeconomy to be sustainable, the bioenergy industry must have a long-term, sustainable, and adequate supply of its raw material, the biomass, at competitive prices.

Overall Impressions

- The goal of this project is to promote the sustainable production of biomass using innovative landscape design tools and to develop an analytical framework to promote changes that enhance the commercial viability of bioenergy. While similar in some respects to the Biomass Production and Nitrogen Recovery project, the team has taken a different approach. I applaud the team on its close connections with industry as well as local government and the farmers themselves. This will be essential to the success of the project. Helping growers to understand being able to grow more biomass and at a lower cost by targeting specific areas in their fields is critical. Getting their feedback as to the minimum subfield size that is doable from a planting and harvesting perspective and then using this in the overall integrated landscape design could be powerful. The work to date shows that an increase in overall biomass availability is achievable with the integration of energy crops resulting in lower cost and with minimal impacts to grain production. The team completed analyses in four counties in the United States showing the feasibility of sustainable integration of energy crops into row crop fields at costs that meet BETO goals. This project provides the framework and support for developing environmentally, socially, and economically sustainable practices for biofuel production. One thing that makes this project relevant is the team's efforts to engage land managers and growers, researchers, the biofuels industry, and policymakers in all aspects of the project. Another is the team's focus on lessons learned and applying what it has learned across differing landscapes and multiple regions. However, at present, the development of tools designed to support the farmer do not have a subfield level resolution. This type of scale will be required to make the work applicable at the individual grower level. Future plans include expanding the analysis to two states, integrating energy crops in row crop landscapes, and establishing viability across diverse and diversely managed lands. I applaud the team's goals to develop and deploy a web-based tool set, data sets, and analysis results. Much more can be done as is outlined in the team's plans for moving the technology forward. I would, however, also encourage looking at some of the softer issues such as how to motivate a grower to integrate bioenergy into their plans, and how can we monetize for ecosystem services with things like clean water credits?
- Given the emphasis on “actionable information” and the connection of this project to other BETO-led efforts, I challenge the team to better communicate how the various components of the project will be rolled into an overarching framework. Successfully executing this portion of the project will have a strong influence on the project's ultimate reach.
- My overriding concern with this project really goes back to comments that were raised in its 2015 review, but weren't addressed in detail in the presentation. How plausible is it to exactly target areas within existing fields for growing energy crops? The assertion that farmers are currently losing money on these areas, but still farming them, makes a prima facie case that micromanagement is not feasible.
- This project seems to assume the planting bioenergy crops where grains are not profitable always benefits the land. I am concerned that future plans outline a complicated modeling tool with very little data to support it. Data collection and model development need to go hand in hand.
- This is a tool for targeting across a landscape based on economic as well as environmental character-

istics. The strengths are the sub-field granularity as well as the integration of different criteria. The integration of harvesting methods and costs based on subfield-level characteristics is also an impressive addition. The analysis seems to assume that there are more profitable bioenergy activities that farmers could pursue on parts of their fields that are not currently being taken advantage of. It would be important identifying what are the reasons that such economic opportunities are being overlooked or not pursued and doing some focus groups or field tests of the hypotheses. Also, it would also be important to explicitly incorporate assumptions about uncertainties and unobserved heterogeneity of land quality and other factors to examine how these are likely to affect the findings.

The public nature of the tool is very attractive. However, a main challenge is accomplishing the goal of delivering “actionable” information. Before investing in many of the possible next steps for the modeling, it seems essential to conduct more stakeholder engagement with the potential users to identify what would be most useful to deliver on the goal of “actionable” information at the producer as well as landscape planning levels.

- The project is making good progress in establishing the framework. It would have been nice to hear more about the pieces, how they work (e.g., what goes in and what comes out), and how they will/could be built together into a tool that is useable by stakeholders.

PI Response to Reviewer Comments

We will strive to better communicate how the various components of the project will be rolled into an overarching framework, as suggested by the reviewer.

In response to the reviewer’s statement, “However, at present, the development of tools designed to support the farmer do not have a subfield level resolution,” the frame-

work is developed with subfield as the smallest unit and therefore results can be obtained at subfield resolution.

The goal of this project is to provide analysis on alternative production options that a producer may adopt to mitigate financial losses that are currently occurring at the subfield level, and are both financially and operationally feasible. While these practices, or any subfield alternative practices, are being widely utilized, our hope is that by performing this analysis we will increase the producers’ options.

We agree with the reviewer that “It would be important identifying what are the reasons that such economic opportunities are being overlooked or not pursued and doing some focus groups or field tests of the hypotheses.” Our project is designed to provide technical, sustainable, and economically feasible solutions to make subfields profitable, which can be used in focus groups and field tests.

Heterogeneity of land quality, climate and crops are explicitly factored in our assessments. However, because of the large computational requirements to assess tens of thousands of subfields within a county, explicit propagation of uncertainties using Monte Carlo-type methods are not feasible at present. In future work beyond FY 2017, we are proposing to incorporate uncertainty through sensitivity analysis using well-defined alternate scenarios of management practices, crop rotations, and nutrient applications, as examples.

We are working closely with Antares Landscape Design project to elicit stakeholder inputs with regard to scenario development and clearly defining actionable information from our toolset.

The project has defined a methodology to down-select from unprofitable subfields and focus only on those subfields which can meet or exceed yield and harvesting cost thresholds for residue and energy crop production. Therefore, the project does not assume that planting bioenergy crops where grains are not profitable always benefits the land.

BIOFUEL AIR EMISSIONS ANALYSIS

(WBS #: 4.2.1.30)

Project Description

The public expects, and the biofuel industry implicitly promises, a more sustainable product across all environmental attributes as compared to conventional fuels. The goal of this project is to perform analyses to better understand air emissions from the biofuel supply chain, applicable air regulations, and implications for cost, operations, and sustainability. Project outcomes include information; data; and tools that will aid in many key decisions including process design configuration, location, and supply chain considerations. Our modeling approach combines work performed by other national laboratories, empirical data, emissions factors, process modeling, and a review of existing permits. Technical accomplishments include air quality assessment of *BT16*, regulatory analyses of DOE conversion technologies, cost implications of air-quality mitigation strategies, and air emission estimates for DOE conver-

Recipient:	National Renewable Energy Laboratory
Principal Investigator:	Danny Inman
Project Dates:	10/1/2010–9/30/2018
Project Category:	Ongoing
Project Type:	Annual Operating Plan
DOE Funding FY 2014:	\$600,000
DOE Funding FY 2015:	\$550,000
DOE Funding FY 2016:	\$558,000
DOE Funding FY 2017:	\$650,000

sion technologies. Future work will focus on continued assessment of DOE conversion technologies and the public release of the FPEAM.

Overall Impressions

- This project strives to better understand air emissions from various biobased processes across the entire supply chain in an effort to see how well these emissions meet applicable air regulations and the implications for cost, operation design, and environmental sustainability. The purpose is to use the

Weighted Project Score: 7.4

Weighting: For ongoing projects, there is equal weighting across all four evaluation criteria: Approach, Relevance, Accomplishments and Progress, and Future Work.

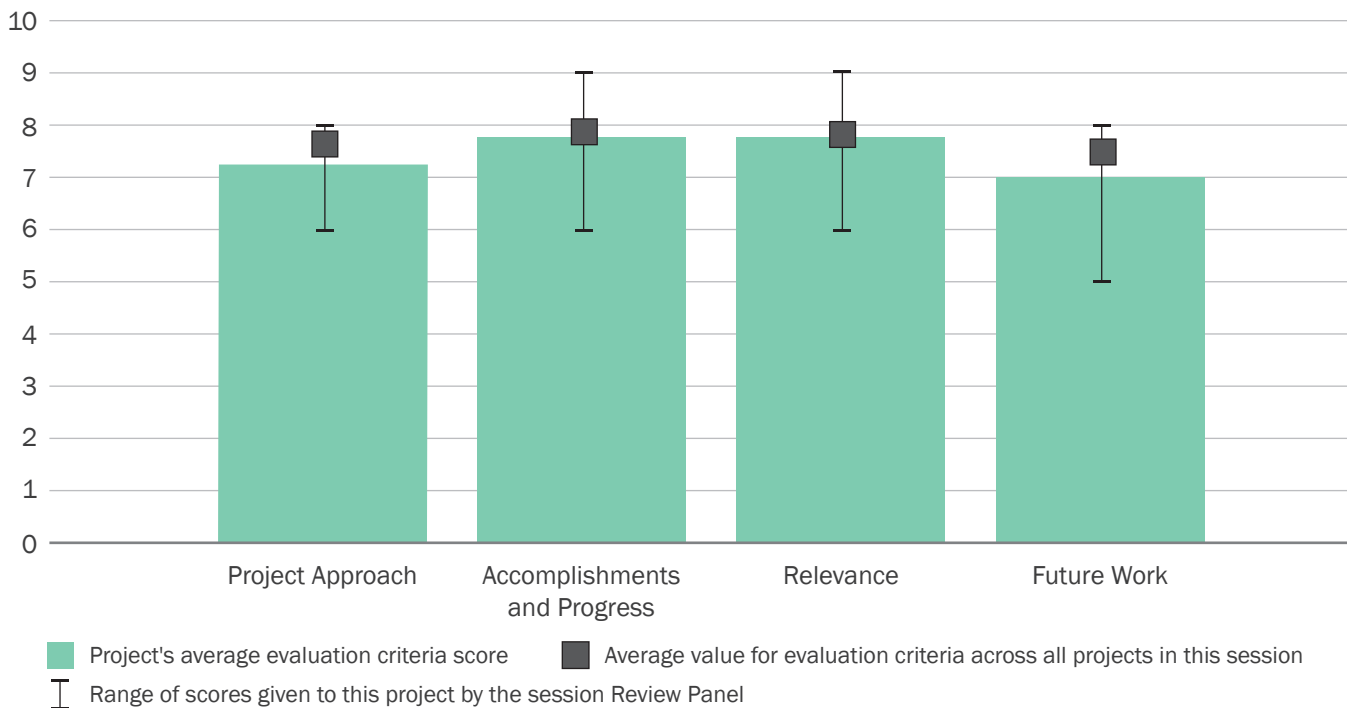

information gathered to aid future biorefiners and other decision makers in making the best choices in process design, biorefinery siting, and supply chain considerations. Because the intent is to impact decision makers, it is critical to interact with stakeholders throughout the project in order to solicit their input on project results and future direction. This project contributed significantly to understanding of the air quality and pollutant emissions for selected biomass production, transportation, and processing scenarios that were used in *BT16* by incorporating spatial and temporal distributions of air emissions and analyzing how these changes could potentially impact local air quality. The project also looked at new conversion processes such as the sugars to hydrocarbon pathway. These results will enable biorefiners to understand the cost implications of potential mitigation strategies thereby minimizing adverse impacts. Air quality is an important aspect of sustainability because of its potential impact on human health and the environment. Like ANL's water quality modeling, this project seeks to facilitate the sustainable deployment of advanced biofuels by providing estimates, in this case, of air quality and pollutant emissions across the biofuel supply chain. The model development and findings from this study enable air emission mitigation strategies to inform process and cost modeling as well as impact biorefinery and supply chain design considerations. It is particularly important to identify those parts of the process that cause a majority of the emissions so mitigating strategies can be taken to make the process more sustainable. Because this project seeks to inform not only the biorefiners themselves but local and federal air quality agencies, it is critical to get this information into the hands of the public and especially decision makers. It is good to see that the researchers are working to publish their findings in peer-reviewed literature. However, making the model publicly available would help to accomplish this goal. I would like to encourage the researchers to not only continue to build out the model by assessing new conversion technologies but to spend

some time refining FPEAM so that it is user friendly and in a format, that can be shared with others.

- It is difficult to discern the true breadth (and therefore, contributions) of the project given the materials provided. Presentation materials were fairly general, so attention is necessary to more clearly identify the project, its specific outputs, the format and use of the outputs, and how outreach with external stakeholders will be conducted. It is clear that good work is being done, so the question becomes how best to communicate that.
- This project fills a niche that needs to be addressed in the interests of completeness: air pollution from biomass production and processing. The results suggest that these concerns may not be quantitatively very important, however (e.g., meeting regulatory requirements may have only about a 1% effect on costs). While it is useful to establish this, and the results of the project may be helpful in informing required permitting procedures, this may be a subject that does not merit a great deal of additional investigation. Just to be clear, I'm not saying that this effort is not good and useful, it is, but the utility of the project may lie in its definitive settlement of the issues it considered.
- The project is an important contribution to enable a view of the air quality impacts of bioenergy feedstock production. It will be critical to ensure that this framework either directly or in complement with other modeling can evaluate the downstream processing and combustion air quality impacts. This will be essential for providing a comprehensive comparison of air quality implications relative to fossil and other alternatives.

The project also is important for its practical aim of providing decision support tools and directly supporting regulatory and planning processes at federal, state, and local levels. It will be important to ensure coordination and alignment with potential users to guarantee the highest value and applicability of the project.

PI Response to Reviewer Comments

- 1. Discussion of particular tasks and outputs would have been appreciated. Thanks for the input. In the future, we will provide more detail on tasks and output specifics.
2. Define more specifically the regulatory and supply chain planning needs and how this project could help. We have performed several regulatory analyses that directly address the federal regulatory framework and how a given design case fits into that framework. Within these analyses, we define that pertinent federal regulations that apply to the given design case, what adjustments could be made to meet the federal regulations, and finally what adjustments may be required to meet best available control technology requirements, which are an upper bound. The state-level regulations vary by state, which makes a state-specific assessment difficult to perform unless we are assessing a specific case study. We have plans in FY 2018 to begin looking at a case study which will entail state-level regulations. Successful application of our work would include design cases that incorporate mitigation options as defined by our work as well as collaborating with biorefinery designers working on the ground. As for other agricultural air-quality models, FPEAM fills the gap in that we assess the major emissions sources related to agricultural production. We do not tie directly into any specific agricultural air-quality models, though we have met with researchers from USDA and presented FPEAM to them.
 3. Whether there were any surprising findings, as a result of the more sophisticated modeling, relative to what was expected at the beginning. We aim to perform more sophisticated modeling and case studies as we move forward. We are objective in our approach and if we come across findings that are contradictory or surprising we will investigate and understand the insights thoroughly.
 4. Greater emphasis on how deliverables may be used. We are still in the development phase of FPEAM as a tool. As we proceed through this Fiscal Year and next (FY 2018), we anticipate having beta testers of the tool as well as conducting outreach efforts to local and state agencies as well as academia. Specific users already identified include the EPA, California Air Resources Board, and the University of Minnesota. We hope to expand that list of users as we proceed and will tailor the tool based on feedback from beta testers.
 5. Why the project did not consider processing and combustion emissions, which are critical to understanding the overall life cycle impact. This project has progressed in a linear fashion moving down the supply chain from feedstock through fuel production. We have not taken on the end-use phase of the life cycle because the needs of BETO and budget have not allowed for a thorough exploration of this phase of the life cycle. That said, one of our long-range goals has been to conduct a full supply chain assessment for a given fuel pathway.
 6. Milestones, decision points, and challenges were not provided in sufficient detail. This is good feedback and we will work to address these items more clearly in future presentations.
 7. Spend some time refining the FPEAM model so that it has a user-friendly format that can be used by others. We want to make the FPEAM tool as useful as possible. We will be following standard software development and release protocols as we move forward. This includes a beta and alpha testing phase prior to release.
 8. Ensure that this framework is either directly or in complement with other modeling. We will be working with stakeholders, including other modelers, to seek feedback on our work. Through this effort we will strive to ensure cross-model compatibility at least in terms of inputs and outputs.

NREL INTERNATIONAL SUSTAINABILITY

(WBS #: 4.2.1.31)

Project Description

The project analyzes and synthesizes key global bioenergy/bioeconomy activities to identify opportunities and address challenges to stimulate the U.S. bioeconomy and improve sustainability. Partnering in bioenergy and sustainability assessment is conducted for U.S. government/BETO United Nations– or IEA-related multilateral initiatives, updated periodically. Under this task, the project team designed a systematic process to evaluate tools to assess the environmental, economic, and social sustainability of various biomass and bioenergy systems through collaboration with the IEA Bioenergy community. The team is also assessing voluntary sustainability standards (VSS) and started to regionalize the Roundtable on Sustainable Biomaterials (RSB), a leading VSS. RSB drafted the application of its principles and criteria

Recipient:	National Renewable Energy Laboratory
Principal Investigator:	Helena Chum
Project Dates:	10/1/2013–9/30/2019
Project Category:	Ongoing
Project Type:	Annual Operating Plan
DOE Funding FY 2014:	\$270,000
DOE Funding FY 2015:	\$352,000
DOE Funding FY 2016:	\$200,000
DOE Funding FY 2017:	\$300,000

to the United States and provided a draft corn stover removal protocol for U.S. conditions, considering prior U.S. information. The PI addressed a gap in modeling and energy security and bioenergy for the Scientific Committee on Problems of the Environment (SCOPE) update. This project’s relevance includes the following: (1) engaging international partners on improving sustainability models and metrics and expanding the knowledge base for sustainability analysis, which is critical for the success of an advanced bioenergy industry,

Weighted Project Score: 8.0

Weighting: For ongoing projects, there is equal weighting across all four evaluation criteria: Approach, Relevance, Accomplishments and Progress, and Future Work.

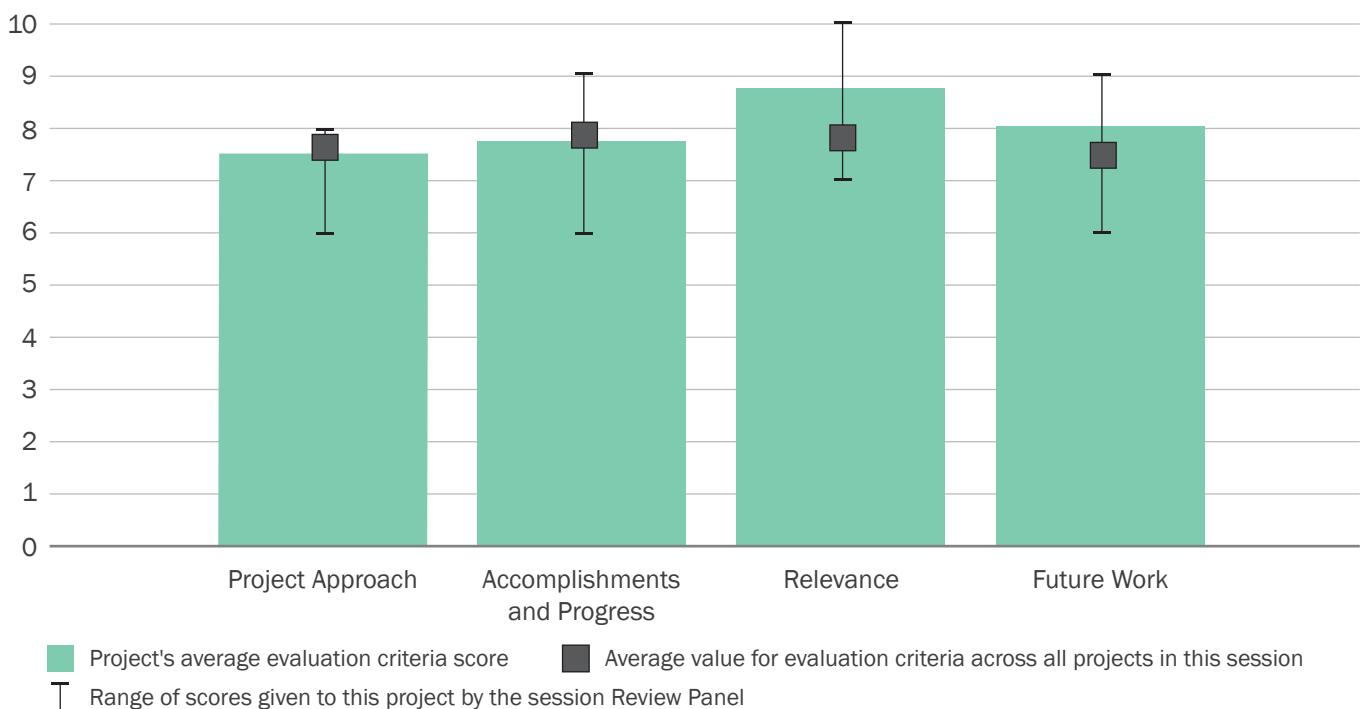

and (2) work to decrease barriers to international trade from the United States. The task will continue (1) to assess sustainability evaluation tools in various bioenergy and bioeconomy contexts, (2) to assess VSS, and (3) to partner with ORNL, ANL, and INL on sustainability of integrated systems.

Overall Impressions

- This project strives to engage with international partners to improve sustainability models and metrics and expand the knowledge base for sustainability analysis critical to the success of an advanced bioenergy industry. Dr. Chum's vast network and participation in international forums helps to highlight all of the work sponsored by BETO. It also helps to mitigate potential barriers to growth in the bioeconomy by having a seat at the table. The work is highly leveraged and crosscutting. Collaboration is key in a project of this type. This work helps to identify the opportunities and address the challenges necessary to stimulate the U.S. bioeconomy and improve sustainability. The work is primarily a continuation of the activities since the last review. Project activities include improving the sustainability assessments of integrated biobased systems, assessing voluntary sustainability standards, and participating in multilateral bioeconomy assessments. Value from this project comes from its ability to analyze and synthesize key global bioenergy and bioeconomy activities and thereby, identify opportunities and challenges for the expansion of the U.S. bioeconomy and sustainability. In a project of this scope, it is critical to prioritize and select activities that address gaps or where confusion exists. Engaging with key international partners on this work is critical. Future work will be a continuation of the work listed above. Since this project is basically to ensure a scientific U.S. perspective in global discussions, continued communication will be critical. I applaud the efforts around harmonization of models and assumptions to ensure a more apples-to-apples approach. As always, due to limited resources, the work should be focused on the most critical issues.

However, it is good to see that the work being done here, like the bioenergy and sustainability paper, is being read and moving the discussion.

- The project appears to play an analytical support role to a variety of ongoing processes. Future work is envisioned, and the process by which decisions are made to pursue discrete tasks under the project was detailed, addressing what would otherwise be my only concern with the project. I was likewise heartened to learn of substantial formalized and informal interaction between BETO project teams working on similar issues (e.g., sustainability).
- It was difficult for me to get a good sense of the objectives and accomplishments of this project. It seems that it has been successful in highlighting U.S. engagement in international sustainability efforts. Its specific achievements in this regard are more nebulous, however.
- This project provides technical expertise and participation in international processes on bioenergy sustainability assessment and is one of the most strategic initiatives in BETO's portfolio. It directly supports the goals of promoting greater understanding of sustainability and providing strategic, science-based communications to drive commercial development of sustainable bioenergy technologies. Participation in international fora is key to ensure alignment of standards at the global level to reduce trade barriers as well as ensure BETO's portfolio of research and expertise has a two-way channel of communications regarding leading science and best practices. The accomplishments in terms of contributions to high-impact reports and processes under IPCC, IEA, and SCOPE are among the most impressive in the BETO portfolio. The support of processes and assessment in Brazil is also strategically important. Finally, the participation in the voluntary RSB standard could also have a high impact.

The top challenge to maximize strategic value is to identify the most critical issues of alignment/misalignment emerging from the international discussions and to ensure strong channels of com-

munications to and from BETO's broader portfolio of initiatives. It would be particularly important to establish a regular communications channel from each of the other major BETO projects with this project to ensure best practices are channeled to and from the international community.

PI Response to Reviewer Comments

- The PI and team thank the reviewers for the insightful comments, suggestions, and recognition of the value of the high-level publications that resulted from activities we performed. The reviewers summarized very well the difficulty of assessing the broad fields and linking to and from the communities (United States and international) the major gaps of understanding sustainability of biomass, bioenergy, and products systems. Many gaps result from lack of understanding of the more distributed U.S. government system compared to the majority of the European countries. In addition, many scientific and social science communities involved are not aware of each other's activities and their work impact on integrated assessment models used to assess bioenergy as part of agriculture, forestry, and waste management on sustainable development including climate. We are hoping that through the Bioenergy KDF's sustainability page our key information will be found by U.S. participants, international collaborators, and others including VSS and BETO, and through the links to other national and multilateral programs. ORNL and NREL are working on this draft webpage as a potential for dissemination of information and a source of comments from the international community as well. ANL, INL, PNNL will review the proposed page and contribute in future if this go/no go milestone receives the go ahead to continue. For GHG emissions, looking at fossil energy use and other metrics, there are accessible tools to allow for harmonization of LCA efforts to directly attribute inputs and outputs within the analysis boundaries. Going outside these boundaries to understand emissions over time, space, economic sectors (consequential analyses), and policy impli-

cations, methodologies have not reached convergent results and research continues. For the environmental and social indicators, the level of agreement is not the same with significant differences between the United States and European countries. Tools for some components are addressed by the program. Our future work will test multiple approaches and show alignment/misalignment in methodologies used.

The United States has multiple data sources and methodologies to evaluate the bioeconomy. We will follow EPA's environmentally extended methodology on an economic input and output basis (by ingwersen.wesley@epa.gov and collaborators). USDA has a different database and open access tool for LCA rich in biomass production data. The harmonization analysis shows that it is important for the actual data for LCAs to come from the country where the resources are used to make the products and fuels. Additionally, many countries lack data on ecological impacts. Improved harmonization will be more feasible in the future as more countries develop their own data sources (e.g., detailed inventories of GHG emissions and removals). The data need to be obtained and this is a very strong aspect of BETO through ORNL, ANL, INL, and collaborators' projects, including the USDA, and is already embedded into the efforts of the current IEA Bioenergy Intertask.

Specific activities in the reporting period (October 2016–April 2017) include the following: (1) RSB North American regionalization (project's first year); (2) Brazilian work (first year of the Brazilian work and second of the U.S. work); (3) understanding the various ongoing multilateral programs and activities, in this case resulting from agreement on the Agenda 2030 of the United Nations on Sustainable Development Goals (August 2016) and the Paris Agreement on climate (November 2016) (first year of funding); (4) linkages between models (previous and first year funding); (5) SCOPE update (new); (6) standards alignment—time did not permit us to show the mapping of efforts.

FORECASTING WATER QUALITY AND BIODIVERSITY

(WBS #: 4.2.1.40)

Project Description

The emerging bioeconomy has raised public concerns about adverse effects on biodiversity and water quality. This project previously demonstrated benefits of perennial feedstocks in two tributary basins of the Mississippi River in a joint effort to examine effects on Gulf hypoxia. We participate in Hypoxia Taskforce meetings and recently co-organized an exploratory workshop on ‘Bioenergy Solutions to Gulf Hypoxia’ to highlight the economic value of improving water through advanced bioenergy. This project also led two chapters of *BT16* volume 2. Conservation practices made it possible to increase yields with lower effects on water quality and changes in avian richness were estimated under Billion-ton assumptions. We are developing models to identify strategies for co-producing wildlife and bio-

Recipient:	Oak Ridge National Laboratory
Principal Investigator:	Yetta Jager
Project Dates:	10/1/2010–9/30/2017
Project Category:	Ongoing
Project Type:	Annual Operating Plan
DOE Funding FY 2014:	\$200,000
DOE Funding FY 2015:	\$300,000
DOE Funding FY 2016:	\$350,000
DOE Funding FY 2017:	\$400,000

mass in two different production systems. In the Pacific Northwest, forest thinning may reduce wildfire, produce biomass, and restore listed salmonids. In Iowa, crop management protocols will be designed for USDA lands designated for pheasant recovery.

Overall Impressions

- This is an ambitious project designed to address the concerns that a growing bioeconomy places on water quality and biodiversity. The project seeks to

Weighted Project Score: 8.3

Weighting: For ongoing projects, there is equal weighting across all four evaluation criteria: Approach, Relevance, Accomplishments and Progress, and Future Work.

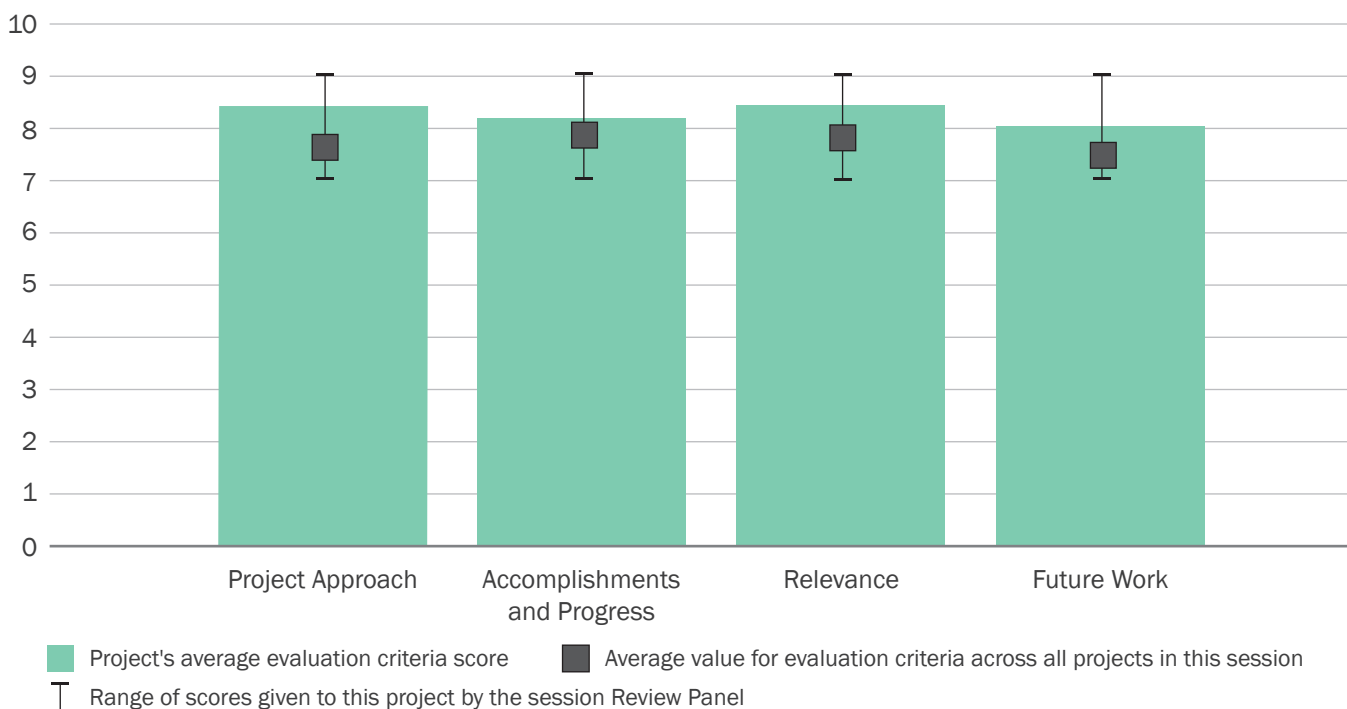

collect large-scale data and develop the tools necessary to optimize for sustainability in an agricultural system with large-scale bioenergy crop production by linking the management of biomass feedstocks to the consequences for wildlife and downstream water quality at different spatial scales. Key accomplishments include using the team's modeling tools to contribute to two chapters in *BT16* volume 2.

The first looked at simulated water quality and yield responses with different conservation practices for a landscape consistent with *BT16* assumptions in two river basins with different feedstock signatures, and the second produced national-scale estimates of bird richness and range shifts under *BT16* scenarios. Both of these efforts required extensive data collection and analysis including scaling down county-level data to meet their watershed requirements. The project addresses a number of BETO goals, but more importantly, helps promote a better understanding of landscape design approaches that enable increased bioenergy production while still providing clean water and enhanced ecosystem and social benefits. As we move to increased biofuel production, it is important to understand and promote the positive economic and environmental effects of biofuels production activities while reducing the potential negative impacts. Sound science and best management practices resulting in win/win opportunities for water quality improvements while increasing the potential feedstock supply will help to drive the acceptance and the profitability of large-scale bioenergy production. An example of this can be seen with the forest thinning project which seeks to supply biomass while reducing wildfire and promoting better salmon habitat.

Moving forward, the work to quantify bioenergy influences on nutrient exports and, in particular, addressing solutions to the hypoxia in the Gulf will be important. The work on the thinning of western forest to promote biofuel and salmon production is another good example of using the tools devel-

oped to address specific issues that could have large potential impacts. It would be good to understand how these specific examples could be generalized and used to identify positive management practices on a wider national scale. Efforts to use the information generated from these projects to influence or identify landscape design guidelines for improving water quality and biodiversity under a variety of landscapes could provide insight into the impacts of producing bioenergy crops at a larger scale. I would encourage the project team to look at the lessons learned to identify similarities and differences that could be applied more broadly.

- Generally, the project provided well-documented evidence to support accomplishments and future work. I appreciate that the PIs placed the work and success factors in the context of major challenges, making it easier to see the contributions of the project.
- This presentation summarized an impressive array of good work. The concern I have, however, is that the project's results must be seen in the right context. While it may be that the production of biomass crops results in lower water pollution than would be generated by the dedication of the same lands to conventional crops, those conventional crops would, by and large, be produced somewhere else. Thus, water pollution issues associated with their growth would be transferred, not necessarily obviated. It is unreasonable to expect one project to deal with all of these complicated issues, but it is important to (1) present results with reasonable caveats and (2) think about how the findings of this project might be integrated with higher-level modeling of integrated food and biomass production.

An interesting aspect of this project is how it integrates with other work described in the BETO portfolio, including the effects of fire suppression on salmonid populations in the Northwest and the striking finding on Slide 20 that the last bit of land

pressed into biomass supply contributes astronomical (comparatively, at least) quantities of reactive nitrogen loading. Documentation of this result as a general finding across landscapes and regions could inform important conservation and production decisions.

- This project appears a model of how technically innovative analysis of sustainability can be used for practical applications to illustrate trade-offs, as well as win/win opportunities. The project also seems a model of a project that is well integrated and nested with other projects in the portfolio and to have a good approach for dissemination and communication of results as well as practical policy-relevant applications in support of stakeholder needs.

Close coordination with potential users within and outside government will be critical to maximize the potential. In terms of success factors, the project would do well to consider a goal in terms of practical application in one of the other projects in addition to technical accomplishments.

It would be beneficial to ensure coordination between this project and the ORNL project to define sustainability metrics for the portfolio (#4.2.2.40) to ensure synergies and provide a potential test case. It would also be helpful to spell out connection to other projects, including the Antares-led project (#4.2.2.60) which has a focus on conservation reserve programs and ORNL's project on forest restoration (#4.1.1.52).

- This project has been successful in providing results for water quality and biodiversity outcomes associated with biofuel production. These are two key impact categories for understanding the sustainability of biofuel feedstock production systems.

While it wasn't discussed explicitly in the presentation, there would appear to be a synergy between the watershed water quality modeling and landscape biodiversity modeling occurring in this project.

Moving forward, it would be helpful to more clearly define the synergies, data flows, communication, and transfer of methods between the two aspects of the project.

The production of two chapters for *BT16* volume 2 has served to coordinate efforts in this project around clear questions and deliverables. The report clearly plays an important role in bringing together a wide range of BETO efforts into a single coordinated product.

The models of species biodiversity offer a perspective not provided by other projects in the portfolio we reviewed. The performance statistics for the species biodiversity models presented in Chapter 10 of *BT16* volume 2 demonstrate the promise of the models. However, the findings of Chapter 10 show that it would be interesting to apply the models to a wider variety of situations. The authors do not find a significant benefit for strip harvest and indicate that the findings might be different for a scenario where harvesting leaves patches with a higher area to perimeter proportion. The authors also caveat their findings with a number of simplifying assumptions about the behavior and life cycles of the taxa considered and the habitat provided by the biofuel feedstocks (e.g., *Miscanthus* is assumed to not provide habitat).

Moving forward, it would be beneficial to focus on improving the biodiversity models for the purpose of screening biofuel feedstocks for their effects on biodiversity. The results of the work so far are promising. The authors offer a few suggestions of how models could be improved in terms of increased inclusion of taxa and improvement in assumptions regarding the crops, landscapes, and animal behavior. In terms of priority, it would appear that refining the models for the already selected set of taxa and getting to the point where the models are able to clearly distinguish crops and management practices that have significant benefits for biodi-

iversity should take priority over adding new taxa. Once the models are robust and promising crops and management practices have been identified, it would make sense to add taxa to screen for potential trade-offs across species. The work should have a go/no go decision point related to demonstrating identification of crops and management practices that result in significant differences in species diversity.

PI Response to Reviewer Comments

- In response to Reviewer 2, we agree that the supply curve result is a striking finding, and we hope to elevate our collaboration with ORNL Resource Assessment to publish these results.

Several reviewers have mentioned a need to generalize from the more local- or watershed-scale biodiversity task/studies to increase the study's relevance.

COLLABORATIONS TO ASSESS LAND EFFECTS OF BIOENERGY

(WBS #: 4.2.1.41)

Project Description

LUC issues are formidable and contentious barriers to an expanding biobased economy. The project objective is to transform the LUC bioenergy debate from its focus on concerns to one targeting opportunities to improve land management. As part of the project, a new LUC paradigm will be developed and supported through collaborative research with IEA Bioenergy, Research Collaboration Networks at the National Science Foundation), and other agencies and programs. Publications, and strategic international communications will be leveraged to support U.S. goals for growth in value-added biobased production, jobs, and secure, domestic energy. The expected outcomes include (1) better practices to consistently assess LUC; (2) standardized definitions

Recipient:	Oak Ridge National Laboratory
Principal Investigator:	Keith Kline
Project Dates:	10/1/2013–9/30/2017
Project Category:	Ongoing
Project Type:	Annual Operating Plan
DOE Funding FY 2014:	\$250,000
DOE Funding FY 2015:	\$200,000
DOE Funding FY 2016:	\$250,000
DOE Funding FY 2017:	\$350,000

and methods for reference case and land/management; (3) more-efficient compliance with market sustainability requirements; (4) reduced barriers to trade and investment; (5) and mitigated social and environmental concerns driven by LUC assumptions (e.g., food-security, biodiversity, deforestation, and GHG emissions). Publications, presentations, and online materials will help DOE quantify the benefits to be derived from a U.S. bioeconomy and support BETO goals to (1) “validate

Weighted Project Score: 7.2

Weighting: For ongoing projects, there is equal weighting across all four evaluation criteria: Approach, Relevance, Accomplishments and Progress, and Future Work.

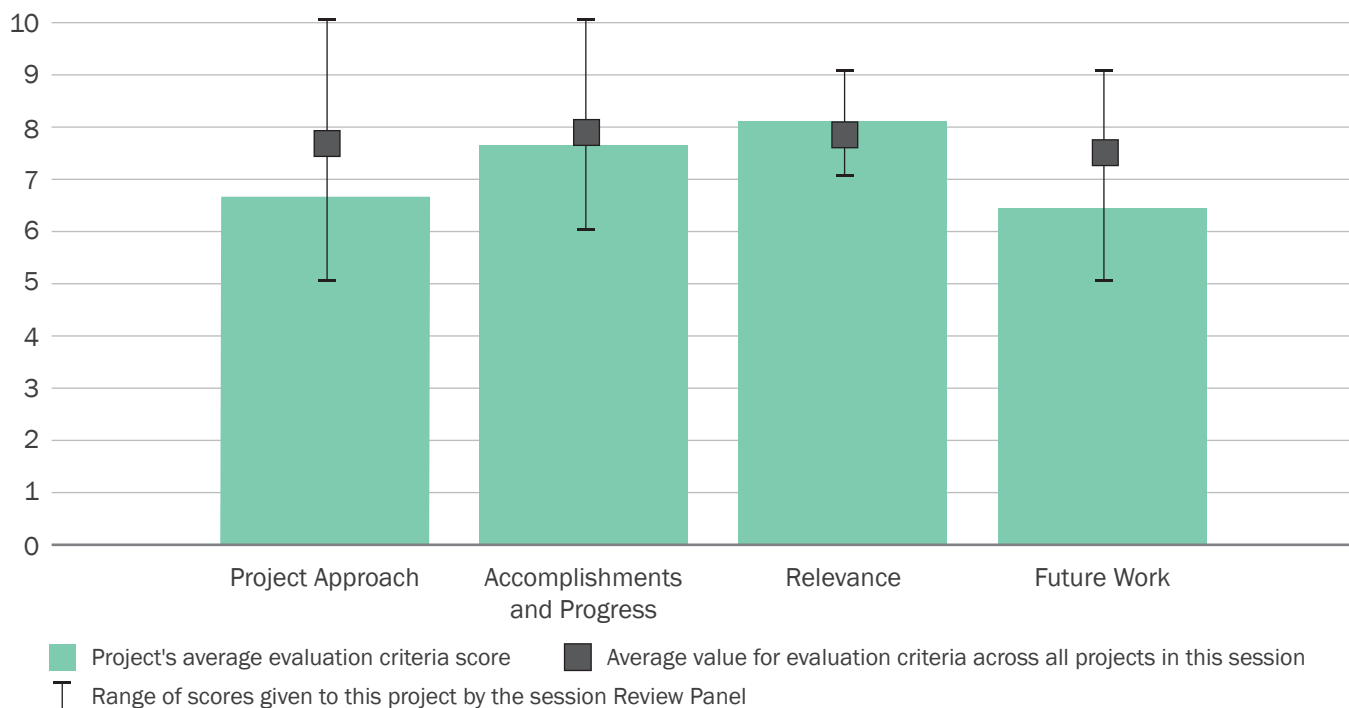

case studies of feedstock production systems [and]... identify strategies to translate beneficial practices into broader applications,” and (2) “quantify and clearly communicate the environmental and socio-economic benefits of emerging advanced bioenergy pathways.”

Overall Impressions

- The goal of this project is to transform the LUC bioenergy debate from its focus on concerns to one targeting opportunities to improve land management for food and energy security as well as other social and environmental benefits. This shift in critical thinking highlights the value of this project which takes a scientific approach to impacting decision making. The project is a great example of collaboration across a wide network of stakeholders and strategic partners. The work leverages other BETO research and places a high priority on outreach and publications in an attempt to increase international awareness of sound, science-based messaging. Since the last review, the team has produced 21 publications, including a chapter in *BT16* volume 2 on LUC, made 38 presentations, and successfully influenced the publication of the ASTM International and International Organization for Standardization international standards. It is great to see this type of outreach since it is critical to ensure that the standards set are in line with U.S. interests.

I consider the work on LUC to be of particular importance. Incomplete information and uncertainties around the LUC issue have the potential to undermine the acceptance of not just bioenergy but all biobased materials. This project excels in forming strategic partnerships and using a science-based approach to generate more reliable LUC assessments, thereby switching the thinking from a negative to an enabler. This work is making a difference. It strives to answer critical questions impacting the sustainable development of the bioenergy industry and the bioeconomy as a whole and works to ensure that the

information generated by the project is made available to the global community. Future work will include joint research around science-based approaches to promote beneficial LUC that are cost-effective, practical, and shift the debate to improving land management for food and energy security. I think it is important when tackling this work that the team broadens its focus to include bioproducts and other aspects of the bioeconomy and not restrict its work to biofuels only. It is also critical when influencing policy to get the incentives right (e.g., carbon tax). Expanding this work to look not just at standards but policy implications could be beneficial.

- This project has achieved substantial progress and has several high-level accomplishments to point to. As a project that is intended to be wide ranging and responsive, I challenge the project team to more clearly communicate how analytical or support needs will be identified, what the process is for selecting particular project activities, and what the approach will be for implementing them.
- There is an underlying ambiguity in this project between whether it is intended to do research or to promote research that has been done. Either might be a worthy goal, though if it is the latter, it is important that the research results be chosen carefully and presented without bias.
- The project’s stated aim is to “transform the debate” on LUC and bioenergy from focus on concerns to targeting economic and environmental opportunities. While the work appears scientifically grounded and impactful, the framing seems to assume rather than deriving the conclusions and focusing on the “debate” instead of changing the ultimate policies and impacts. This seems to undermine the scientific credibility of the endeavor. A recommended alternative framing of the goal would be to conduct research to build the rigorous evidence base on the actual land-use impacts of bioenergy policies, under different approaches, and to promote policy recom-

mendations to help ensure that bioenergy policies deliver the anticipated win/win.

The project has a large number of publications and reports as well as outreach presentations in a variety of fora. The project also has a very long list of proposed future plans. While impressive, a more focused and prioritized research agenda on high-impact publications, including potentially a high-profile synthesis paper, would likely ensure greatest chances of success.

- The topic of LUC is a relevant one for bioenergy systems and this project demonstrates that the project team is highly connected to international efforts in this area. What is not clear from the presentation is the research approach. It would be nice to see the specific research questions being addressed, the approaches planned, and the metrics for success. As it is, the project appears as a collection of opportunistic efforts and quick response capabilities. For effective management, it would be helpful to focus on key outcomes the project supports and to design the effort to provide outputs that support those outcomes. The project should track metrics for success and in the next review present progress against those metrics.

As it is, it is easy to see this project is doing a lot, but it is particularly challenging to evaluate the effectiveness or scientific integrity of this project based on the presentation.

PI Response to Reviewer Comments

- We appreciate the comments and plan to implement reviewers' recommendations to
 - Document the selection criteria applied for selecting project activities

- Consider LUC in the context of 'other aspects of the bioeconomy' beyond biofuels
- Increase focus on strategic, high-impact collaborations including at least one high-profile research paper
- Generate credible, science-based analyses to test hypotheses
- Ensure that results are shared with BETO and other laboratories.

Incorporation of these recommendations in work plans will be reflected by milestones and metrics to facilitate tracking progress. Among the criteria considered to select activities are EERE's high impact, "additionality" (e.g., can we make difference and not duplicate private-sector work?), openness/transparency, enduring economic benefits to the United States, proper role of U.S. government, and addressing strategic priorities.

This is not an "advocacy" project. Rather, we collaborate on research and dissemination of results while consistently advocating for science-based approaches to analyze LUC. We energetically agree on the importance of documenting how research results support (or do not support) clearly defined hypotheses. We will continue to strive to develop and apply the "Causal Analysis Framework" and complementary analyses of empirical data to test hypotheses.⁴⁰ Thus, we endorse the recommendations to focus squarely on rigorous research and science-based discovery to generate policy-relevant and actionable results. By involving others in the research discovery process, this project will continue to leverage resources to achieve multiplier effects in terms of research, outreach, and impacts. Here is an example of the evidence of the multiplier effect: DOE and ORNL did not have any press releases on

⁴⁰ Rebecca A. Efrogmson, Keith L. Kline, Arild Angelsen, Peter H. Verburg, Virginia H. Dale, Johannes W. A. Langeveld, and Allen McBride, "A Causal Analysis Framework for Land-Use Change and the Potential Role of Bioenergy Policy," *Land Use Policy* 59 (2016): 516–527, <https://doi.org/10.1016/j.landusepol.2016.09.009>.

the food security paper but due to the collaborative nature of the work, other research partners ensured that over 60 different media releases across four continents announced the new publication within 10 days of its release, contributing to a record-setting number of downloads as reported by the journal over the following 6 months (media report available from BETO or PI).

We agree with reviewers that LUC is a global issue which requires engagement of conflicting views to build consensus. It was reassuring to see agreement across a diverse Review Panel regarding the high relevance of this project's research and the progress made to date in addressing stakeholder concerns related to LUC. We acknowledge that the

goal statement to “transform the LUC debate” may not be the best choice of words, so we will collaborate with BETO on alternative framing that better reflects reviewer recommendations to (1) build a rigorous evidence base on the actual land impacts of bioenergy policies; (2) develop and communicate recommendations to a wide audience; and (3) help to guide development of a U.S. bioeconomy toward “anticipated win/wins,” which represent core goals for our work. Shifting an established global paradigm is a “stretch goal.” While it may be beyond our control, we will do our best to achieve results via strategic interventions and persistence. Thank you for your thoughtful contributions to the effort.

CARBON CYCLING, ENVIRONMENTAL & RURAL ECONOMIC IMPACTS OF COLLECTING & PROCESSING SPECIFIC WOODY FEEDSTOCKS IN BIOFUELS

(WBS #: 4.2.1.60)

Project Description

The project will quantify global warming impacts for regionally specific woody feedstocks from commercial softwood systems and short-rotation woody crops (SRWC) and provide LCA inputs for ANL’s GREET team. This work is done in close collaboration with that team to ensure these analyses are consistent with current GREET scenarios. This work includes regionally specific commercial softwoods and SRWC from three U.S. regions (i.e., the Pacific Northwest, Southeast, and Northeast). These woody feedstocks are used as inputs

Recipient:	Consortium for Research on Renewable Industrial Materials
Principal Investigator:	Steve Kelley
Project Dates:	8/31/2010–3/31/2018
Project Category:	Ongoing
Project Type:	FY 2009–BRDI: DE-PS36-09G099016
Total DOE Funding:	\$1,430,535

for the DOE thermochemical process model, which has been modified to be sensitive to biomass composition, ash content, and moisture content. The LCA impacts of variations in woody biomass growth rates, chemical properties, and the allocation of woody biomass for durable wood products, paper, and biofuels are being quantified. The environmental burdens will be allocated to durable wood products, paper, and the biorefinery feedstocks. The impact of the extended temporal aspects includes of durable wood products (20–70 years), paper products (2–5 years), and commercial forest rotations (25–80 years),

Weighted Project Score: 7.9

Weighting: For ongoing projects, there is equal weighting across all four evaluation criteria: Approach, Relevance, Accomplishments and Progress, and Future Work.

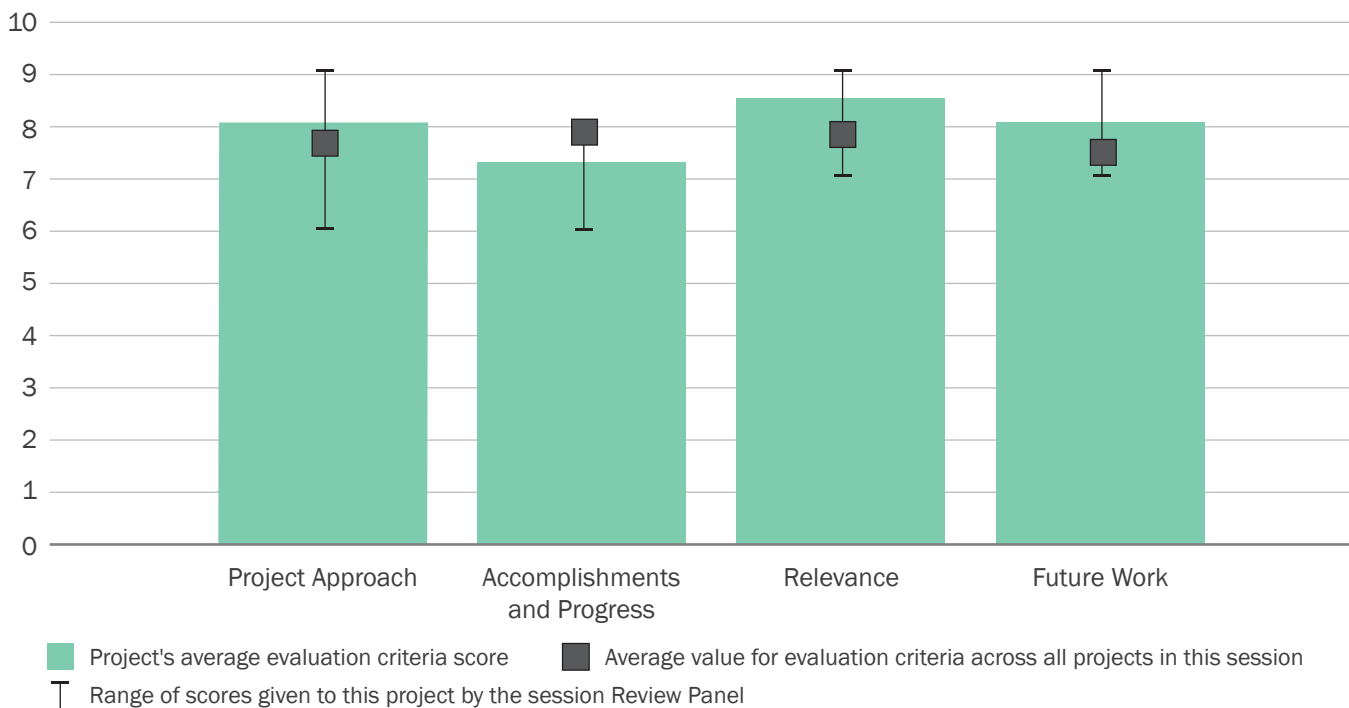

their disposal or decay, and the variations in commercial practices between regions. The current demand for commercial durable wood products and the unique role of forests in the minds of the American public means that the sustainability of woody biomass systems attracts more attention than many other biomass sources.

Overall Impressions

- The goal of this project is to understand the carbon flows for woody biomass allocated to durable uses such as wood and paper products versus bioenergy products and evaluate the implications for different forest management systems. Understanding the life cycle impacts is especially difficult given the differences in product life spans. The carbon in durable wood products may be sequestered for many years while the carbon in bioenergy systems may be released immediately. Therefore, understanding the assumptions and uncertainties is critical. The project is highly collaborative and strives to produce data that are consistent with and can be utilized by GREET as well as other BETO projects. The team has made good progress since the last review completing Tasks 1 and 2. Specifically, they have completed life cycle inventories for six biomass production systems and completed the allocation to products pools for two of three systems. Of note is the teams' work on understanding the compositional differences between wood types and updating the model to reflect this. Understanding the compositional differences is very important but leads me to question whether or not the quality (e.g., increased levels of inorganic material) of the wood feedstock would also impact the LCA especially when looking at residues versus purposely grown woody crops. Adding this to the analysis would be beneficial. The team is working closely with ANL to ensure consistency. This is important in dissimilar systems since the assumptions and allocation methodology can have a great effect on the analysis and finding.

Allocation of burdens between the various products and co-products is especially difficult due to the uncertainty of use and product life cycle. The outcomes of this project will aid in understanding the sustainability of forest systems and their use for bioenergy. While the direct customer for this work is the GREET model, this work will also be valuable to other teams and will help provide a better understanding of the forest carbon cycle for other BETO program areas. Future work will be to address Tasks 3–5. I would also suggest looking at not just the environmental impacts but the economic impacts as well. For example, not just measuring how much wood residue or thinnings are available but how much can be economically collected and the logistics of collection.

- The hiatus in the progress of this project has meant that it is not as far along as it might have been, and, consequently, it is more difficult to assess its achievements and prospects. As the presenter notes, specifying a counterfactual baseline for the analysis will be essential in assessing what the net economic and environmental consequences will be. My overriding impression is simply that we will have to wait until the project is farther along to better evaluate it, but that the plan for future work provides some basis for optimism.
- This project addresses a critical need to assess the impacts of woody feedstocks. This was a gap in *BT16* volume 2 and a priority for BETO to address. This is a key issue for making the environmental case for alternative woody feedstocks and important for public policy on bioenergy in the United States and worldwide.

The integration with GREET is particularly valuable but broader dissemination as a standalone product should also be considered, including through the Bioenergy KDF platform.

The discounting approach for temporal impacts is appropriate but sensitivity to alternative discount rates should be considered.

It would also be valuable to contextualize results and the modeling approach with other U.S. and international forestry modeling frameworks (e.g., from the Subregional Timber Supply, Forestry and Agricultural Sector Optimization, and the Global Timber Models).

Characterizing the regional and temporal heterogeneity of results under the “business as usual” and “management” scenarios, accounting for different management practices, species mixes, ecological and climatic regimes (e.g., residue decay rates), will be critical to provide policy-relevant information and show how results depend on timeframe and spatial scales. Creating a flexible tool that allows analysis and visualization of alternative scenarios might be of higher value than generating results for particular assumptions.

- This is an important project for creating LCA and consensus models from experimental and other forest biomass research by presenting in a way that is useful for decision making and providing it through the GREET platform for use by others.

It would be helpful to more clearly lay out the research questions being addressed, specific actions which will be used to answer the questions, and plans for disseminating findings. The plans for future research should be more clearly laid out.

PI Response to Reviewer Comments

We appreciate the reviewers’ recognition of the overall importance of the work, the value of the regional approach, the complexity of the systems, need to include uncertainty and the natural variation of the woody biomass, and strength of the collaboration between the Consortium for Research on Renewable Industrial Materials and GREET.

While there are many additional aspects of these complex forest systems and an almost infinite array of alternative counterfactuals, we agree that this initial work will provide a robust foundation for future work by this team and other groups interested in forest systems.

We agree that the inclusion of economic considerations and the additional of visualization tools would be a useful next step, but note that this work is outside the scope and budget of the current project.

BIOMASS PRODUCTION AND NITROGEN RECOVERY

(WBS #: 4.2.2.10)

Project Description

This project aims to bolster the cost competitiveness of bioenergy through the valuation of ecosystem services produced by bioenergy crops in landscape design. It does so by (1) generating primary data from field experimentation to develop new, engineering-based best practices incorporating bioenergy and conservation and (2) modeling at a small-watershed scale two water quality-enhancing landscape designs, integrating bioenergy with grain crops and conservation. Working at these scales addresses the challenge of understanding local stakeholders' options and needs. Results from the multi-year field study point to a dramatic removal of nitrates in the subsurface in conjunction with an experimental willow buffer, and the watershed scale analysis has shown substantial potential benefits at costs that are competitive with mainstream

Recipient:	Argonne National Laboratory
Principal Investigator:	Cristina Negri
Project Dates:	10/1/2010–8/28/2019
Project Category:	Ongoing
Project Type:	Annual Operating Plan
DOE Funding FY 2014:	\$540,000
DOE Funding FY 2015:	\$540,000
DOE Funding FY 2016:	\$600,000
DOE Funding FY 2017:	\$630,000

conservation practices. Stakeholder input is sought through periodic engagement via workshops and field meetings. This project has also provided a framework to evaluate the costs of biomass production and logistics, and the value of ecosystem services generated. This framework will be integrated with LCA and used in the future as a comprehensive blueprint to conceptually scale up to the entire agricultural U.S. agricultural landscape. If successful, this project will show a path toward improving bioenergy penetration and yield in the Corn Belt, with

Weighted Project Score: 8.4

Weighting: For ongoing projects, there is equal weighting across all four evaluation criteria: Approach, Relevance, Accomplishments and Progress, and Future Work.

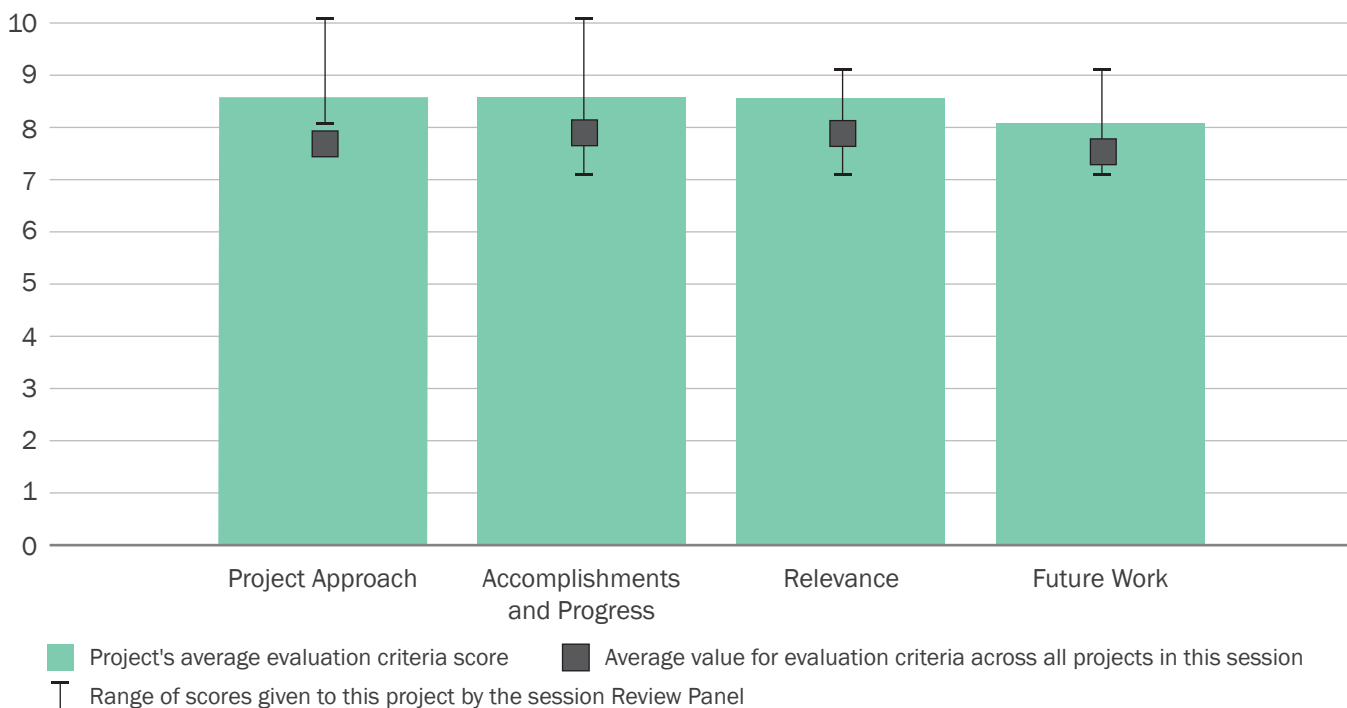



concurrent benefits in reducing water quality problems, such as Hypoxia in the Gulf of Mexico.

Overall Impressions

- This project studies how we can, as part of the bioeconomy, optimize the production of biomass while still providing environmental services. This project starts at the farm level and works to scale up lessons learned to the watershed level. An important aspect of this project is providing value to the farmers to encourage them to integrate bioenergy crops in their current systems. The project is well managed and highly collaborative. In a project of this nature, engaging the various stakeholders, particularly the farmers, is critical. Since the last review this project focused on more ecosystem services, developed TEA of production and logistics at the watershed scale, and worked to understand the potential nutrient markets to provide a viable solution to nutrient loss reduction. I am impressed with the amount and type of data collected in this project. I also found it interesting that the team exceeded its target of a 30% reduction in nitrate concentrations in soil water in 2015. That is why, even though the team found that producing willow was not cost-effective for the farmer, mostly due to high land rents, we need to consider the value things like reducing nitrates and other ecosystem services should have to society as a whole. We should also consider, if providing these services is something we would like to encourage,

what kind of incentives would work. It is also important to understand at what point alternative crops become cost-effective on marginal or less productive areas. This project strives to address barriers in sustainability and sustainable feedstock supply while at the same time providing farmers with added value for adopting bioenergy.

The work and goals of the project are certainly relevant with moving the bioeconomy forward while promoting sustainable solutions. I agree with Dr. Negri that bioenergy is neither good nor bad, but that it is how we deploy it that matters. Improved landscape design could produce biomass in a manner that is positive for the environment and bring added value to the farmer. As far as future work, the team plans to continue its field trial through the next harvest cycle, improve on its landscape design, continue to develop the economic framework and analysis, and develop pathways to include bioenergy landscapes in conservation BMPs. It will be important to better understand the cost competitiveness of bioenergy compared to other conservation practices and engage with farmers particularly on lessons learned. Willow was probably not the best choice for this study.

I understand the team's past work and expertise in the area but starting with a crop more familiar to farmers that could still offer environmental benefits may have been more appropriate. However, the team has generated a vast amount of data and learnings which could be used in testing other cropping systems. Also, providing a set of best practices would be a good outcome for this work as would devising tools that could be used by others. Understanding the scale at which these crops need to grow to be both economically and environmentally effective is important. Also, how would cover crops play into this scenario? Are cover crops effective at stabilizing nitrates while also providing biomass?

- All in all, a well-designed and implemented research project. The methodology is appropriate to the questions being asked, experimental design is robust, and external outreach and engagement help to leverage resources and ensure relevant stakeholders are aware of the work.
- I am quite impressed with this project. It was well designed and carefully conducted. While some might see a project with negative results as a less productive use of funds than one that points to a “success story,” we need careful, even-handed investigations of hypotheses under consideration. This project provides relevant information for not only its own context, but that may be helpful in designing programs elsewhere.
- The team collected a lot of valuable data. This project would be stronger if experimental data collection and modeling efforts were more closely linked.
- The project focuses on (1) buffer planting of willows around corn fields and has a detailed field-level component to measure yield, nutrient runoff, and other environmental indicators; (2) a watershed-level modeling exercise; and (3) an associated economic analysis. The study demonstrates the potential role of bioenergy crops to provide biomass as well as nutrient reductions and other environmental benefits. This is exactly the type of analysis that BETO requires to achieve its goals of validating landscape design approaches for at least two bioenergy systems that increase land-use efficiency. The project has an excellent set of research and technical partnerships, as well as community engagement effort, and provides a model for other similar studies for assessing environmental and economic performance at different spatial scales.

The main issue seems to have been the initial choice of the cropping system which was found to be un-economic. A key question is whether sufficient testing and evaluation were conducted to identify

the environmentally and economically most promising technology before investing in the major effort to conduct the detailed assessment. A high-priority next step is establishing a pathway for bioenergy landscapes as part of conservation BMPs. A priority for the economic and environmental analysis is to be able to show the benefits and trade-offs relative to other alternatives to deliver biomass, economic benefits, and nutrient reduction (and potentially other environmental services). The study should also focus on demonstrating and communicating a methodology that best establish a replicable model for other studies.

- Field studies such as this one are important for providing data that can be used in models that extrapolate the results after the project is completed. Moving forward, it is important to consider how the results of this project will be used in order to ensure the data collected and disseminated are as useful as possible. It would be helpful for the project team to demonstrate stronger connections to the other techno-economic and environmental analyses occurring in BETO.

PI Response to Reviewer Comments

- While some might see a project with negative results as a less productive use of funds than one that points to a “success story,” we need careful, even-handed investigations of hypotheses under consideration. The main issue seems to have been the initial choice of the cropping system, which was found to be un-economic. We do not see our results as negative, and simply changing the crop system (technology) may not have changed the profitability outcome. Conversely, our work examines a different economic framework that monetizes the production of biomass and favorable, by design, environmental services (which we successfully proved), which are the two outcomes that the landscape design mode was set to obtain.

We hypothesized that landscape design plantings could be costlier than business as usual (BAU) cropping because of increased distances traveled by equipment and our results showed that BAU willow cropping systems, switchgrass, and often even corn itself, would not provide profitable margins from selling the crop biomass alone under these conditions. In some cases, however, the landscape design case would be better than BAU because of lower fertilizer costs and optimized space utilization. We are providing a value proposition for farmers and for society. In other words, our work seeks to answer the question: Would the environmental benefits, if monetized, be a useful way to bolster the profitability of bioenergy in the Midwest while addressing the societal problem of addressing water quality problems associated with corn cropping? As one reviewer correctly stated, the research community needs to determine the societal value of nutrient reduction.

It would be helpful for the project team to demonstrate stronger connections to the other techno-economic and environmental Analysis occurring in BETO. We have already started the integration with LCA and look forward to working with other PIs as we scale up the model.

Willow was probably not the best choice for this study. Starting with a crop more familiar to farmers that could still offer environmental benefits may have been more appropriate. The system tested in this field study can be described as an example of mixed cropping or agroforestry, as it involves a woody crop. Agroforestry practices have been

developed and deployed nationwide for all areas where agriculture could be better managed with buffers, windbreaks, and other landscape features. While less familiar to farmers than grasses, we did not encounter particular resistance to willows and farmers have anecdotally been receptive to most crops whose biomass would have a viable market.

The study should also focus on demonstrating and communicating a methodology that best establish a replicable model for other studies. This is planned for FY 2018 and FY 2019, when we will have all the physical models, LCA, and TEA elements of the broader framework available and we will have had the opportunity of testing an improved design. We are also working toward a coordination of existing field sites that have similar or compatible aims to collaborate on meta-analyses, which would be important for larger scale model validation efforts.

This project would be stronger if experimental data collection and modeling efforts were more closely linked. While the field study only analyzes the willow/corn system, modeling includes willow, switchgrass, and prairie grasses as data availability allows. The field study has contributed some of its data to the models, but more importantly an assessment of the soil conditions that would be of interest in targeting underproductive or marginal subfield portions. The field site has several marginality conditions that were used for the watershed study. As mentioned before, watershed models need to be validated by more than one field site, but our work provides a solid foundation for future additional field sites.

We thank the reviewers for their positive comments.

BIOENERGY SUSTAINABILITY: HOW TO DEFINE AND MEASURE IT

(WBS #: 4.2.2.40)

Project Description

This project defines “bioenergy sustainability” and establishes methodologies for measuring and assessing progress toward a sustainable bioeconomy. Building from our previously proposed indicators and analyses, we focus on (1) developing and testing the overall approach, (2) conducting case studies to validate and further develop our approach (e.g., using switchgrass in east Tennessee, woody residues from the Southeast, and cellulose in the Midwest), (3) applying the theory of aggregation to bioenergy sustainability, and (4) constructing visualization tools. These efforts have moved from establishment of indicators to determination of baselines and targets for particular contexts, evaluation

Recipient:	Oak Ridge National Laboratory
Principal Investigator:	Virginia Dale
Project Dates:	10/1/2010–9/30/2018
Project Category:	Ongoing
Project Type:	Annual Operating Plan
DOE Funding FY 2014:	\$700,000
DOE Funding FY 2015:	\$700,000
DOE Funding FY 2016:	\$750,000
DOE Funding FY 2017:	\$800,000

of indicator values, consideration of trends and potential trade-offs/synergies, and ways to develop and test good management practices. This project addresses the following BETO technical challenges and barriers: (1) scientific consensus on bioenergy sustainability, (2) consistent and science-based messaging on bioenergy sustainability, and (3) implementing indicators and a methodology for evaluating and improving sustainability. The project outcomes are moving the bioenergy

Weighted Project Score: 7.5

Weighting: For ongoing projects, there is equal weighting across all four evaluation criteria: Approach, Relevance, Accomplishments and Progress, and Future Work.

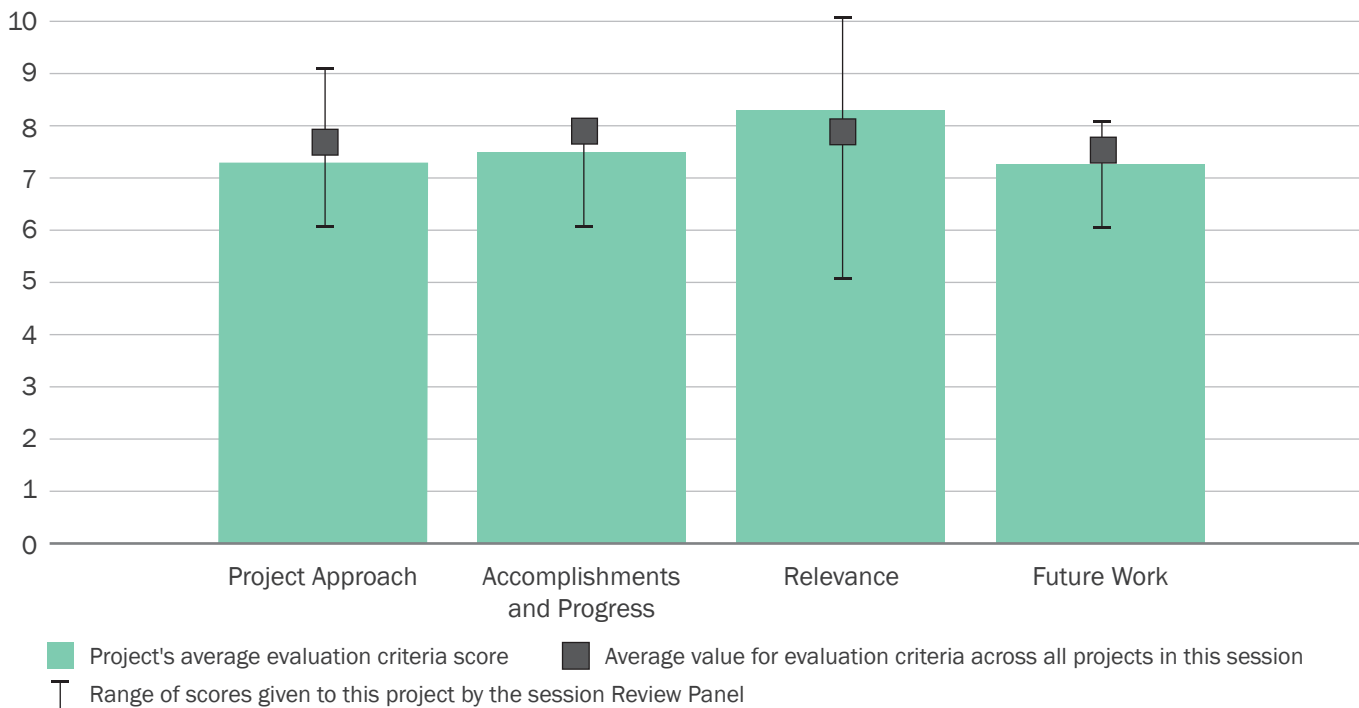

industry toward more achievable, consistent, comprehensive, cost-effective, and legitimate ways to measure and assess progress toward a sustainable bioeconomy as defined by context-specific indicators and targets and as documented through use of our interactive visualization tool.

Overall Impressions

- This project has a rich history defining what is meant by “sustainability” as well as identifying and developing the metrics by which improvements in sustainability can be quantitatively measured. The last two years have seen the emphasis shift from simply identifying the sustainability metrics to characterizing and understating the relationship between various metrics as well as providing a framework to standardize their use. The project appears to be well managed with regular updates, conference calls, and milestones. This is particularly impressive given the large number and diversity of partners with over 70 partners offering in-kind cost share. Coordinating the various leveraged activities, analyses, and perspectives is a daunting task but seems to be well done. Good progress has been made in meeting project objectives. Technical accomplishments for the project included several case studies looking at growing switchgrass in Tennessee and wood pellets for use in Europe. However, the most significant progress has been around efforts to collectively look at the various sustainability metrics and to ensure sustainability goals are met in the overall ecosystem. This requires normalizing and aggregating data to better understand the overall picture. Normalizing and aggregating a host of different indicators is not easy. The project has accomplished that by setting baselines and quantifying progress around those values. Because weighting the various indicators is often subjective and depends on the unique goals of a particular system, it was appropriate that in this study all 35 metrics were not weighted to give one

number. The researchers did however provide the tools necessary so that stakeholders could, according to their needs and interests, aggregate the values in a way that is consistent with their requirements.

The term “sustainability” was used repeatedly in all of the project reviews as well as during the plenary talks. This indicates how important this work is in serving as a foundation to all of the rest of the work BETO is doing. This project, in particular, helps to provide a level setting by defining what “sustainability” is and how it can be measured. The true value of this project is to get people thinking about a broad umbrella of indicators especially going beyond the traditional environmental indicators and including economic and social impacts as well. It will be important as the project moves forward to enable the use of best practices by providing examples of how these various metrics can be assessed, integrated, and effectively visualized. This includes making sure that all of the appropriate stakeholders are at the table. Since conveying the results, especially when looking at such a wide array of environmental, economic, and social indicators can be daunting, future work includes developing a visualization tool to effectively display progress towards sustainability. It will be important as the project moves forward to enable the use of best practices by providing examples of how these various metrics can be assessed, integrated and effectively visualized. It will continue to be important to get this information disseminated to as broad an audience as possible broadly and transferring the technology to the appropriate stakeholders.

- The project has succeeded in producing a substantial number of deliverables, products, and workshops. Continued effort should be devoted to reporting the contribution of each to the project’s strategic objectives. This is a massive undertaking, so it is important to all involved, from stakeholder to funder, to know how all the pieces fit together.

- While a tremendous amount of work has been done on this project, I am concerned that it has not yet delivered on the promise of its title by showing how to define and measure bioenergy sustainability. I was reminded in reviewing this project of a remark by the great economist Robert Solow, “It is hard to talk about ‘sustainability’ without defining what it is one intends to sustain.” It seems that this project is providing numerous examples of different ways that “sustainability” has been defined, and how things that determine it have been measured, but it falls short of providing guidance on the crucial questions of how someone could define and measure “sustainability” in any particular context and how those definitions and measures might need to be modified from one context to another. The publications cited on the mathematics of aggregation begin to explore possibilities, but if this project is to provide results that can be reduced to useful practice, it must take a stand on what principles of aggregation might most usefully be applied, and how.
- This project is centrally important to all of BETO’s portfolio and thus needs to be measured to a high standard. While the team has produced a rigorous mathematical framework for multi-criteria analysis, useful visualizations, impressive publications, and interesting applications, the project seems to be falling short of its basic goal of providing greater clarity and rigor over “sustainability” definitions. Rather, it seems to be saying that users can choose their definitions without any constraints, which does not seem ambitious enough for this foundational project. For example, financial sustainability is not a subjective concept and should be measurable over different time horizons. The project team should be less cautious and at least propose some core definitions (e.g., reduction in GHGs as per BETO’s goals and/or financial sustainability) and provide a clear set of answers via the evaluations even if users can also adjust the definitions based on alternative

definitions. Otherwise, the project risks missing out on its potential relevance.

- This is an important project that closely relates to the goals of the A&S platform. It is struggling to address very worthwhile questions. Moving forward, it would be helpful for this project to more clearly address (1) how the framework developed will be extended to future biofuel systems (at a reasonable cost) and (2) how the approach contributes to our ability to perform streamlined and rigorous analyses of other biofuel systems.

The creation of “product category rules” for biofuel feedstock types would be an interesting approach moving forward.

It would also be helpful if this project clearly answered the following questions: (1) What metrics are most important to track for biofuel feedstock systems, and (2) how should these metrics be calculated?

Finally, it would be useful to consider how the project could support making data available for the analysis of future biofuel systems and/or how could data be brought together from disparate sources to support a comprehensive sustainability assessment of biofuel feedstock production systems?

PI Response to Reviewer Comments

- To assess progress toward a sustainable bioeconomy and provide clarity and rigor in context-specific sustainability definitions, our ORNL team developed an approach to assess progress toward a sustainable bioeconomy. The approach has 6 steps.
 - The scope of the assessment is established based on the particular context, options, and stakeholders’ concerns.
 - Indicators that pertain to the objective of making progress toward sustainable bioenergy are selected and prioritized.

- Baselines and targets are determined for each indicator.
- The indicator values are collected and evaluated.
- Trends and trade-offs in the indicator set are analyzed.
- Good practices for the activity are developed and evaluated.

In the effort that preceded the current project, ORNL reviewed the vast literature on environmental and socioeconomic indicators and approaches to characterize progress toward bioenergy sustainability. Based on that review, and in consultation with diverse experts, we selected 12 categories that contain 35 indicators.

The current project is evaluating the six-step approach and, in particular, the 35 indicators via three case studies. We reported on (1) the completed work on switchgrass in Tennessee, (2) the first three steps of analysis of production of wood pellets in the Southeast, and (3) the initial phase of a case involving cellulosic-based energy in Iowa (which was presented by WBS 4.2.2.60).

For the switchgrass case, ORNL worked with colleagues supported by USDA. Information was collected for indicators in all 12 categories. ORNL used that information to proceed through the six-step approach and determined appropriate practices for production of ethanol using switchgrass in east Tennessee. This analysis included multi-attribute decision support systems that illustrated the potential for benefits to be achieved. This case demonstrated the benefits for switchgrass and was a test of the overall approach. We are also quantifying the costs and benefits of applying an existing bioproducts certification scheme to switchgrass in Tennessee. That analysis will reveal if the scheme covers the diversi-

ty of indicators that we have found to be important and if such certification has value to the industry.

For the second case, we have begun applying the six-step approach to production of wood-based pellets in the Southeast. We are focusing on private nonindustrial land, which make up 60% of the timberland ownerships where wood pellets can be produced. Relatively little information exists for these lands. The first steps of the approach require selecting indicators based on the stakeholders' concerns. Hence, we are deploying a survey to private nonindustrial forest landowners to better understand and prioritize their sustainability concerns. To obtain data on some of the indicators, our analysis of FIA data for counties where pellet production has been active revealed few changes in forest conditions during the period when pellet production has occurred. We are also developing a framework to examine effects of wood-based pellets on species of concern and their habitats. Hence, we have made progress on Steps 1, 2 and 3 in this case study.

In addition, we recognize the importance of presenting the information to a diversity of stakeholders. Therefore, we are in the process of developing and testing BioSTAR, the Bioenergy Sustainability Target Assessment Resource visualization tool. This tool presents indicator-specific and aggregated information and will eventually be deployed on the Bioenergy KDF. The aggregation methods employed build from mathematical theory of aggregation as well as multidimensional attribute analysis.

Our future work will be to complete the two case studies and to develop and deploy BioSTAR. Our final synthesis will highlight how the specified indicators and six-step approach can be used to identify best practices for diverse bioproducts.

SHORT-ROTATION WOODY BIOMASS SUSTAINABILITY

(WBS #: 4.2.2.41)

Project Description

Woody biomass is expected to be a dominant bioenergy feedstock in the Southeast; however, environmental effects have not been evaluated. Our project uses a watershed-scale experiment and a distributed watershed modeling approach to evaluate the environmental sustainability (i.e., water, soil, and productivity indicators) of intensive management of pine for bioenergy. Three adjacent watersheds (i.e., two treatment and one reference) in South Carolina were instrumented and baseline data were collected between 2010 and 2012. Next, around 50% of the treatment watersheds were harvested in 2012, planted in 2013, and managed (i.e., multiple herbicide and fertilizer applications) for pine production from

Recipient:	Oak Ridge National Laboratory
Principal Investigator:	Natalie Griffiths
Project Dates:	10/1/2013–9/30/2018
Project Category:	Ongoing
Project Type:	Annual Operating Plan
DOE Funding FY 2014:	\$345,000
DOE Funding FY 2015:	\$330,000
DOE Funding FY 2016:	\$345,000
DOE Funding FY 2017:	\$345,000

2012 to 2016. Forestry BMPs were followed. Baseline measurements showed that groundwater is the dominant flow path. Nitrate concentrations increased in groundwater (<2 mg nitrogen/L) post treatment, but not in stream water, suggesting BMPs protected surface water quality. Plot-scale measurements suggest no fertilizer or half operational fertilizer treatments can satisfy pine nitrogen demand and minimize leaching. Early pine growth was rapid and around 2 years ahead in development com-

Weighted Project Score: 8.0

Weighting: For ongoing projects, there is equal weighting across all four evaluation criteria: Approach, Relevance, Accomplishments and Progress, and Future Work.

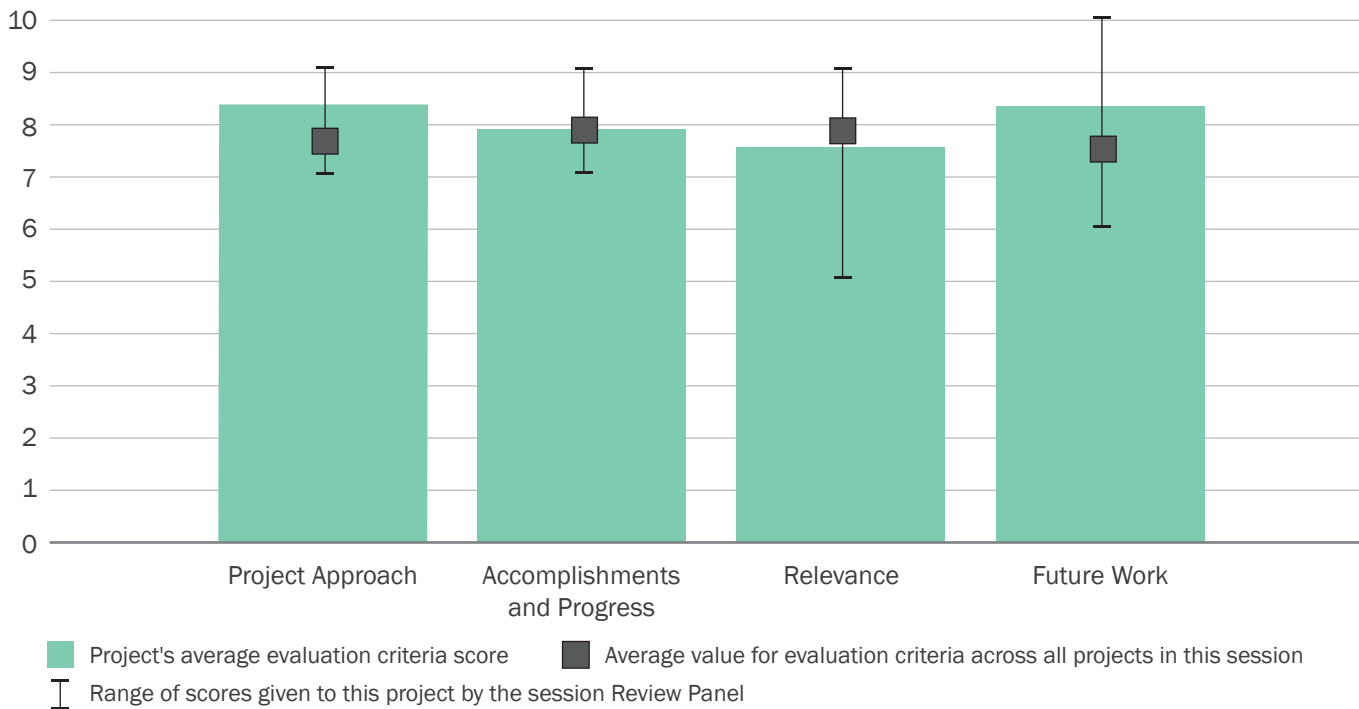



pared to standard timber plantations. Forest management scenarios run with standard models (i.e., MIKESHE and SWAT) and the Oregon State University model developed for the Upper Coastal Plain found variable changes in stream flow, depending on model structure. Water, soil, and productivity measurements will continue through 2018 and model application will occur in parallel.

Overall Impressions

- The Southeast has the potential to produce substantial biomass. This project aims to assess the impacts of intensive short-rotation woody crop production on sustainability metrics such as water and soil quality. Its goal is to understand the effectiveness of current forestry practices and apply them more broadly. The project is well managed with frequent meetings, good communication, and extensive collaboration. The use of specific milestones and go/no-go decisions appears to be effective. The work required extensive data collection on each of the three watershed sites. Results thus far show no impacts to stream water quality and no evidence of water limitation. The crops have shown record growth and are two years ahead of standard growth rates. One of the most interesting results is that the no fertilizer and half optimal fertilizer treatments appear to satisfy the nitrogen demand in pine and minimize leaching. Because of this result, the amount of fertilizer used in the study seems to have been excessive. Also, while model development continues, in some cases, significant differences between models will require additional investigation. The overall importance of this work is in demonstrating that biomass production for use in the bioenergy industry can be accomplished while still maintaining or even improving the environmental conditions of water and soil. Ultimately, this work will be used to assess whether current forestry BMPs are adequate to protect water and soils and will inform industry and regulators. While most of the work is site specific, I would love to see this work be broadened for use not just for this particular region but more globally. Because the project is scheduled to wrap up in 2018, I would urge the team to focus on understanding how the data generated could be used to inform BMPs when producing woody biomass in the Southeast. I think the idea of exploring the use of drones for spatially resolved measurements of sustainability indicators is an interesting one. Any time you can take advantage of new technology to further your research goals, it should be explored. I also understand your concern that changing from an open canopy to a closed canopy may present new challenges and impacts that were not observed in the less mature plantation. Finally, would there be any benefit to studying other SRWCs other than loblolly pine in the future?
- The project appears to be designed and managed well. The project likewise appears to be integrated into other, relevant BETO efforts. I challenge the project team to consider how to better integrate external stakeholders into their work or how to better communicate those efforts that are already being undertaken to engage outside constituencies.
- My main concern with this project is in wondering what its incremental contribution is. It is not clear (1) how much is already known about the environmental consequences of loblolly pine plantations in the Southeast and (2) how much such plantations would differ if they were devoted to crops dedicated

to bioenergy than to lumber and/or pulp production. While these questions seem to have been raised in an earlier review, they don't seem to have been definitively answered, and so it is difficult to come to a judgment as to how cost-effective this line of research is for informing policy.

- There were a lot of experimental data collected, but model calibration and validation results need to be presented to assess model efficacy and necessity for model enhancements.
- This is a well-executed project to conduct experimental measurements, based on before and after comparison, and modeling of the watershed-level environmental impacts of SRWCs in the Coastal Plains region of the Southeast with a goal of testing whether current BMPs are sufficient to ensure sustainability. Among the BETO projects, this is one of the most practical and relevant to demonstrating the sustainability of a promising bioenergy pathway. This is directly relevant to the goal of providing commercial viability of a pathway that improves land use efficiency. It would be helpful for the researchers to provide more background on the relative importance of the chosen region and silvicultural approach and to what extent the findings are generalizable to the most commercially prevalent or likely SRWC approaches. It would also be helpful to include a broader sustainability and economic assessment to demonstrate the broader relevance of this pathway.
- This project plays an important role in furthering the development of environmental hydrologic models through comparing multiple models and validating against field measurements.

Moving forward, it is important the PIs consider how the findings of the field measurements could be extrapolated to other systems. Because of the cost of field measurements, it is important that field experiments are designed to yield data which can help understand a wide range of systems.

Given the shortcomings in “off-the-shelf” models for representing forest systems, it is important to consider how this project could feed back into hydrologic model development information that would help address current shortcomings in the ability to represent forestry systems.

PI Response to Reviewer Comments

Communicating findings/informing BMPs: Each forest-producing state has a water quality forester, and most large timber producing companies are associated with the National Council for Air and Stream Improvement. PI Jackson maintains regular contact with both groups and has communicated results throughout the project. Because of the prevalence of loblolly pine silviculture throughout the Southeast, study results are directly applicable throughout this region. Furthermore, past forest hydrology and BMP research has demonstrated commonality of relevant water quality processes (e.g., importance of bare soils and hydrologic connectivity and the function of riparian buffers) in forest lands in the United States.

Other SRWCs: Loblolly pine is the top candidate for SRWCs in the Southeast. In regions where other SRWCs may dominate (e.g., poplar in the Pacific Northwest), related watershed-scale experiments coupled with modeling should be carried out.

SRWC versus conventional forestry: The woody bioenergy feedstock market can be supplied by tops and limbs harvested from traditionally managed stands, and by SRWCs grown specifically for this market. If there is a sufficient price for woody feedstocks, SRWC silviculture makes sense because trees are harvested at the point of fastest average growth rate, but before stems reach a quality necessary for pulp or lumber production. From an environmental standpoint, the major difference is greater weed control and fertilization prior to crown closure and more frequent ground disturbance in the SRWC system. The advent of intensive SRWC production for bioenergy raised new forest sustainability and

BMP issues for which the traditional forestry BMPs were not designed. Biomass removal and more frequent rotations create the possibility of increased occurrence of overland flow and transport of contaminants.

Our study seeks to quantify water, soil, and productivity changes associated with SRWC production. This research has not been done at an operational scale and current BMPs are untested. Some studies have investigated effects of harvesting SRWCs, but no watershed scale studies focused on the entire production cycle. Several studies have investigated environmental effects of growing pine for timber, but because of production differences with SRWCs versus timber, it is not known whether these findings are directly applicable to SRWCs.

Informing Hydrologic Models: Our model findings will contribute incrementally to the field of hydrologic modeling and will likely be helpful in modeling forest management scenarios in mixed-use landscapes.

Chosen Region: The Southeast is the dominant U.S. wood production region due to a favorable climate for rapid tree growth and that 90% of forest lands are privately owned. Within the Southeast, loblolly pine accounts for the vast majority of wood production. Wide-

spread technical and human infrastructure exists for the growth, harvest, transport, and processing of pine. In terms of the silvicultural approach used, plot studies have shown that maximum production in loblolly pine is achieved by weed control and annual fertilization. We attempted to mimic those studies operationally by applying multiple herbicide and fertilizer applications. We also chose to push the system in terms of early fertilization and weed control beyond current practice to accelerate growth and address potential impacts relative to current BMPs that were not developed for SRWCs.

Sustainability/Economic Assessment: A complete assessment is not within the scope of our project. We plan to do an economic assessment for supplying pine feedstocks at the end of the rotation using local costs and values. Our project team is writing a review manuscript on environmental considerations for SRWC production.

Model Validation: Though, substantial groundwater fluxes from the basin and low stream water yields rendered standard calibration difficult, our distributed measurements of hydrologic states (i.e., groundwater levels, interflow, and soil moisture) allowed multi-objective calibration such that MIKESHE and the Oregon State University models reproduced observed processes.

ENABLING SUSTAINABLE LANDSCAPE DESIGN FOR CONTINUAL IMPROVEMENT OF OPERATING BIOENERGY SUPPLY SYSTEMS

(WBS #: 4.2.2.60)

Project Description

The best and most immediately relevant opportunities to develop and demonstrate innovative and impactful landscape design practices for bioenergy systems exist within the feedstock supply sheds of operating bioenergy projects. This project will be conducted in the biomass feedstock supply sheds serving POET-DSM Advanced Biofuel’s Project LIBERTY biorefinery in Emmetsburg, Iowa and DuPont Cellulosic’s biorefinery in Nevada, Iowa. These are areas where LUC is already underway but is still early in its evolution in supporting the supply chains of groundbreaking cellulosic biorefineries.

Recipient:	Antares Group Inc.
Principal Investigator:	Kevin Comer
Project Dates:	4/1/2016–3/31/2021
Project Category:	New
Project Type:	FY 2015—Landscape Design for Sustainable Bioenergy Systems: DE-FOA-0001179
Total DOE Funding:	\$9,000,000

The project will build from information available from these operating bioenergy systems and collect additional data necessary for addressing barriers and stakeholders’ objectives. Ongoing engagements of stakeholders at key steps in the supply chain will ensure that their objectives and ideas are a part of the evolving design. When fully developed, documented, and demonstrated at these commercial scales, the landscape design activities, associated enabling tools, and best practices developed through this project will serve as important examples for sustainable bioenergy production that can be adapted and imple-

Weighted Project Score: 8.0

Weighting: Approach–25%; Relevance–25%; Future Work–50%.

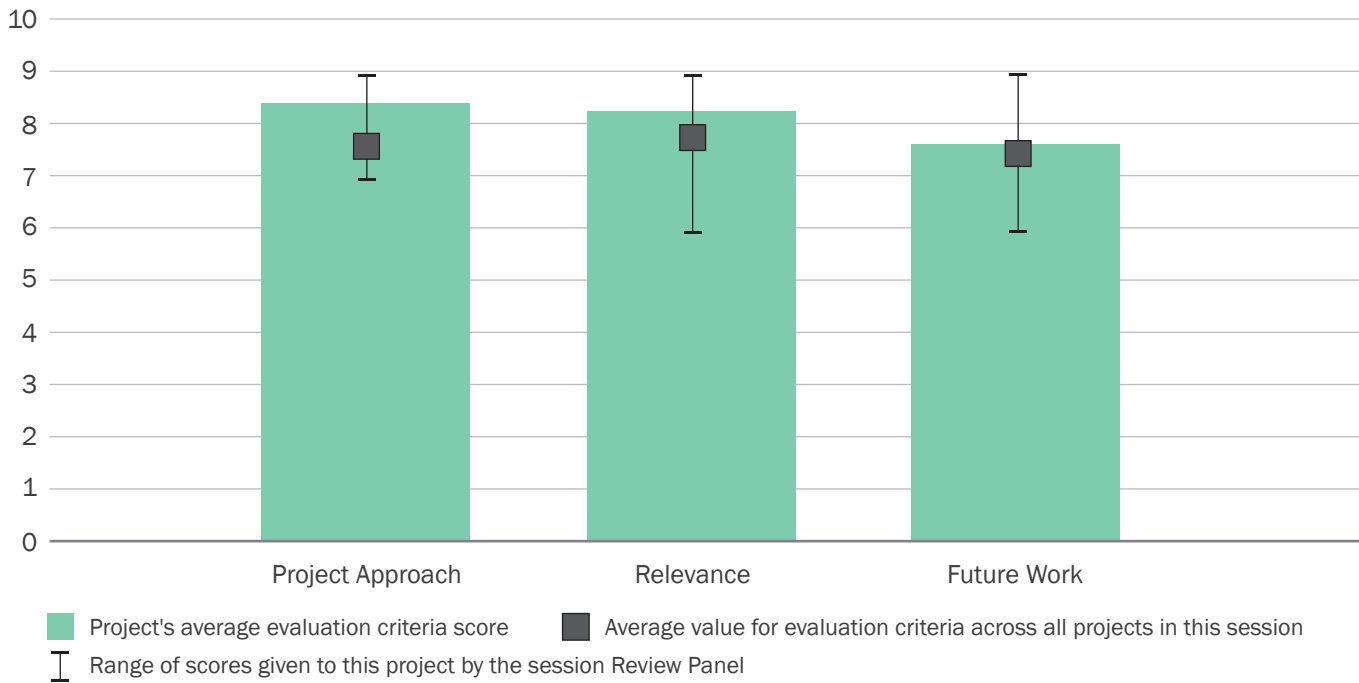

mented nationwide. Our team is focused on sustainable landscape design activities and opportunities in target watershed areas including agronomic and sustainability analysis as well as tool development, field and logistics research, and demonstration work.

Overall Impressions

- This project is somewhat unique in the BETO portfolio. The project aims to work with growers and biomass end users to utilize subfield agronomic models to target areas within the existing feedstock supply to implement conservation practices and monitor key environmental indicators in hopes of better enabling the development of a sustainable biomass supply system. It does this from a bottom up approach. The project's strength comes from the involvement and close ties to growers, the biofuels industry, equipment manufacturers, and others. It is highly collaborative and integrates all stakeholders along the value chain. By involving agricultural students in the work, the project is helping to inform and shape the next generation. I also appreciate the cost share of the partners involved in the project. For being less than a year old, the project has accomplished a great deal. The team has signed up over 3,000 acres to participate in the project, done the initial watershed-level opportunity mapping, field research planning, and initial testing. Work on a web-based sustainability tool is also underway. I find it interesting that between 2 to 3 million acres of crop land are planted each year but are expected to produce a loss. Identifying and using this land for more productive purposes could save over \$1B a year just in lost capital. This project strives to find better strategies for building energy crop supplies sustainably and profitably. It's compelling to think that by adopting a zonal management of the land, growers could save money, grow an energy crop, and provide environmental benefits. However, this will require, as the team points out, changing the culture of agriculture. I like how this project helps to support the State of Iowa's goals to reduce nutrient loss. It will be critical to understand what the minimum size a subfield needs to be so that a change in management practice is practical as well as profitable. Future work will include field selection and data collection, base model development to measure environmental and socioeconomic sustainability indicators, ongoing multi-stakeholder outreach activities, and annual harvesting and monitoring. It will be critical to continue to work closely with equipment manufacturers to develop the planting and harvesting equipment required for some of these new energy crops. One of the most exciting aspects of this project is that the work done in Iowa around the two existing cellulosic ethanol plants could be used to create a template that could be deployed elsewhere. Finally, asking farmers to plant perennials is seen as risky. This project helps mitigate that risk and gives farmers a chance to experience biomass crops so that when the time comes they will be informed and ready. Overall, this is a huge effort, but it has the potential to be very important.
- The project represents a massive and, in my opinion, important undertaking. The project team appears to have established a robust management approach and has already engaged a wide variety of external stakeholders from multiple sectors. I do not have any additional comments or suggestions at this time.
- This is a very ambitious, and expensive project (though with respect to the latter, costs are being shared). Its success hinges on the ability specifically to target areas that would be more profitable growing energy crops than conventional ones. Moreover, its results will only be useful if they can be generalized. It would not be cost-effective to spend this much in analysis for every parcel of a vast landscape, so it is important to determine if phenomena such as the inverse correlation between economic

profitability and nitrogen loss is general. Similarly, we would want to know if such areas are also capable of profitably growing energy crops.

- This is a great project with unparalleled data collection efforts.
- This is an ambitious, important, and complex project--logistically and technically—in terms of validating how state-of-the-art tools and best practices for targeting biomass production can provide economic as well as environmental benefits. The idea of the project is excellent and the stakeholder engagement appears a major strength. The continual improvement aspect also seems innovative. It would be great to be more explicit about how and what information collected would be used for adaptive management over time. It will be critical to ensure well-defined milestones and management practices to maximize the value of this major flagship project.

In particular, on the environmental side, it is not clear what and how environmental indicators are going to be measured and monitored on the field and what was going to be modeled. This will be a critical component to demonstrate environmental and economic performance. It will be important to ensure this project is drawing on some of the best technical practices developed in other projects, for example, the work on evaluating conservation practices to reduce nutrient loss under #4.2.1.10 led by Dr. Negri, on subfield targeting with the Landscape Environmental Assessment Framework (LEAF) model under #4.2.1.20 led by Dr. Nair, and spatially detailed modeling by the University of Minnesota (#1.7.17).

PI Response to Reviewer Comments

- Our project has a very detailed project management plan that is reviewed quarterly with our DOE project managers and our internal project management team. Our team meets monthly with our

DOE project management team to review progress, challenges, plans, proposed adjustments, and issues associated with our management plan. The project has 40 specific milestones and 31 deliverables that are part of our management plan, and our progress is tracked against those metrics on an ongoing basis. There is an annual go/no-go decision milestone associated with our demonstrated progress (at DOE's discretion), and there will be a stage-gate review involving a panel of independent expert peer reviewers about 2 years into our project performance period. We have already exceeded the requirements of several of our peer review metrics. The requirements for accomplishments by our team by the time of the stage-gate review are as follows: (1) accomplished considerable interaction and planning with state and local stakeholders; (2) evaluated and selected target fields and practices for implementation; (3) performed subfield analysis and planning for each field; (4) collected results from initial field baseline monitoring; (5) performed initial harvest demonstrations and related performance monitoring, analysis, and reporting; (6) developed an initial web-based interface for collecting sustainability related information for use in a sustainability certification process; and (7) developed and demonstrated a range of modeling capabilities to assist with the previously mentioned activities and regional modeling of impacts from larger-scale implementation of the conservation and biomass establishment practices considered in the project.

Our project team, with the help and encouragement of our DOE project management team, regularly interacts with the researchers mentioned above and others who are engaged in important work that is relevant to this project. In some cases, such as Dr. Jager's work, our project will serve as a field testing platform and collaborator for a researcher's analytical work—we offer them a field testing environment and case study opportunity, and they provide our

team with the results of their analytical work. In other cases, such as the work described in Dr. Nair's presentation on the LEAF model, those researchers are part of our team and those models are directly incorporated into our modelling methodology. The LEAF model is incorporated into AgSolver's existing set of services and commercially available tools. AgSolver is a vehicle for getting those tools, and new improvements, into commercial application as quickly as possible once those tools and improvements have demonstrated commercial value and readiness. We are open to and interested in collaborating with any researcher or organization that has interest in our project activities, objectives, information, and capabilities or stakeholders that we can leverage to further our team's objectives.

This project's field monitoring results will be used to validate and/or calibrate the software tools our team members are developing, improving, and using. One of the most important outcomes from developing and improving these computer models is building the capability to accurately transfer field research results and measurements (from this and other projects) to broader and different circumstances, without having to incur the same level of field-related effort and expense. Our project is already benefiting from decades of plot-scale field research and geophysical model development. We will build upon that work and demonstrate the usefulness of the resulting modelling tools to assist with improved decision making for farm managers, government program managers, and policymakers.

BIOFUELS INFORMATION CENTER (BIC)

(WBS #: 6.3.0.1)

Project Description

The purpose of BIC is to provide relevant data, information, reports, and web-based tools to all bioenergy stakeholders. This BIC task supports biofuels pages on EERE’s website—the Alternative Fuels Data Center (AFDC; afdc.energy.gov) and the Bioenergy Atlas tools (maps.nrel.gov). The BIC task began in FY 2008 to meet the requirement under Title II, Sec. 229 of the *Energy Independence and Security Act of 2007* which requires DOE to develop a biofuels and biorefinery information center. The task also supports the PI’s time to engage stakeholders on infrastructure and biofuels. This includes leading and participating in committees on biofuels and infrastructure as well as engaging with specific companies needing data and information in this area. In FY 2017,

Recipient:	National Renewable Energy Laboratory
Principal Investigator:	Kristi Moriarty
Project Dates:	10/1/2013–9/30/2017
Project Category:	Ongoing
Project Type:	Annual Operating Plan
DOE Funding FY 2014:	\$200,000
DOE Funding FY 2015:	\$120,000
DOE Funding FY 2016:	\$110,000
DOE Funding FY 2017:	\$500,000

this task grew to include analysis of a USDA’s Biofuels Infrastructure Partnership and the annual *EERE Bioenergy Market Report*. This task results in nearly 800,000 web page views per year on an average budget of \$150,000/year. A key challenge is purchased data set restrictions which are mitigated by working with the vendor to show a range rather than exact data. The outcome and technical accomplishments are heavily used AFDC biofuels pages and Bioenergy Atlas tools as well as two annual reports beginning in FY 2017.

Weighted Project Score: 8.2

Weighting: For ongoing projects, there is equal weighting across all four evaluation criteria: Approach, Relevance, Accomplishments and Progress, and Future Work.

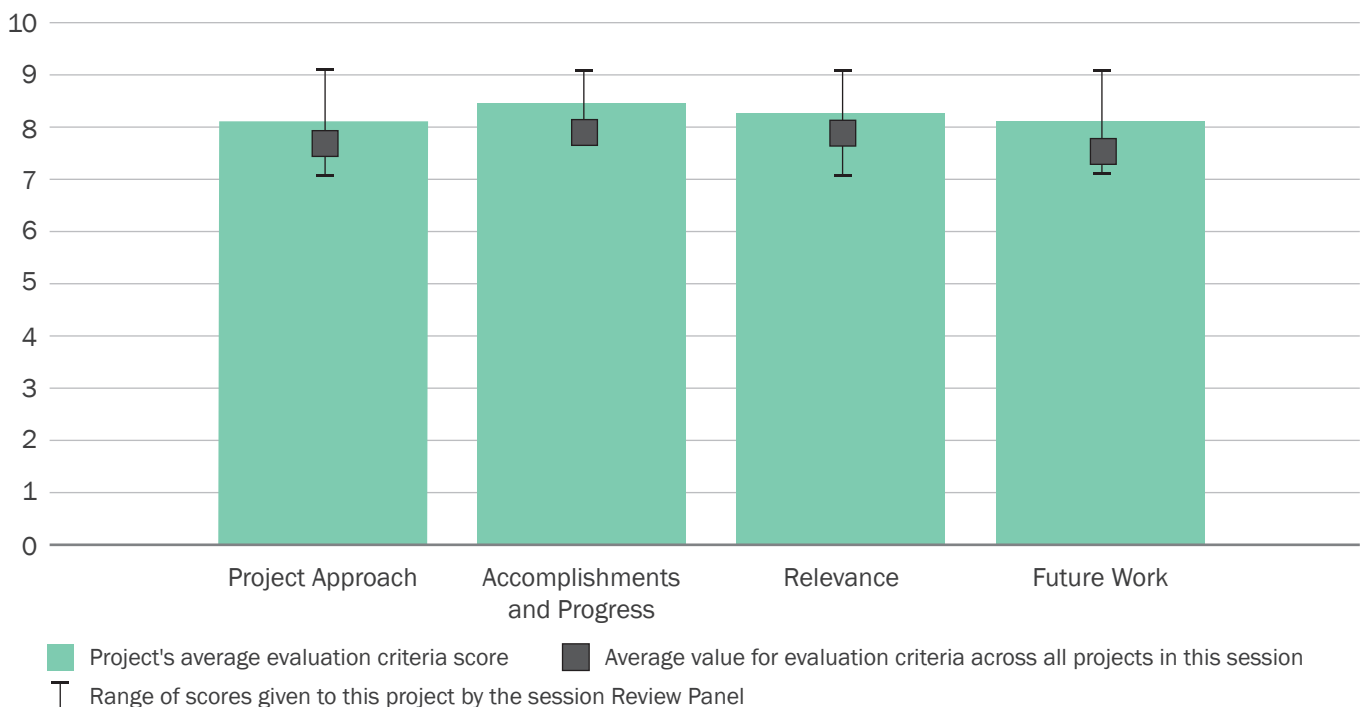

Overall Impressions

- BIC provides essential bioenergy data, tools, and information to all stakeholders. The goal of this project is to enable stakeholders to make informed decisions by providing the information they need. While a small team, the project is well managed with clearly defined goals. It is great that USDA serves as a full partner in this work. Collaboration across the various functions is key. BIC focuses on providing useful bioenergy tools, data, and information. The work includes updating and maintaining AFDC; updating, maintaining, and adding functionality to the Biofuels Atlas and Biopower Atlas geospatial tools; and leading and participating in stakeholder committees and groups on the subject of biofuels infrastructure compatibility. The outreach component of this work is critical. The team uses a variety of methods to highlight its work including webinars which can be an effective method to reach the stakeholder community. BIC is important and helps BETO meet its goal of expanding the domestic bioenergy market by providing current, relevant bioenergy data and tools to a wide group of stakeholders. These stakeholders are often not the scientific community but are fueling station owners, vehicle manufacturers, biofuel producers, local governments, and consumers. Engaging stakeholders helps to debunk myths, create an informed understanding of the issues, and overcome the obstacles necessary to get new fuels into the marketplace. An example BIC's impact is the number of page hits the site receives. In 2016, BIC had over 740,000 page views. Future work will include continued support of AFDC and Biofuels Atlas tools, continued engagement of stakeholders, and completion of the *Bioenergy Market Report*. Because of its deep expertise in dealing with infrastructure issues, it would be great if this team could work with the Co-Optima Market Transformation team to evaluate the necessary infrastructure changes that will be required with some of the novel, new blendstocks.

- In many ways, BIC is hard to evaluate given the legislative or programmatic mandate for many of its activities. Still, the project seemed to have a large reach for a relatively modest budget. The project team demonstrated commitment to stakeholder assistance, potentially multiplying the impact of the program beyond its formal products and deliverables.
- This is a project that involves the collection and dissemination, rather than the production, of data. As such it is more difficult for someone like me, whose expertise lies more in primary research, to assess its merits. I am impressed, however, that usage seems to be high. It will be important to follow usage statistics in the years ahead to see if additional investments might further expand the user base, or if it has plateaued. Of course, it may still be useful to make investments in broadening BIC offerings.
- This seems like one of the most widely used bioenergy data- and tool-dissemination vehicles. As such, it is a critical challenge to stay current and maximize value to users. The project is doing an impressive job of generating downloads but could incorporate even more outreach to users as well through webinars and other efforts to promote broader knowledge and usage of Atlas and other tools.

It would be valuable to present more information on how this website fills a gap relative to what is being provided by private industry and others and on the usage compared to other pages at DOE and other organizations.

It is also critical to cross-fertilize investments in this, Bioenergy KDF, and other dissemination platforms to ensure cost-effectiveness and maximize exposure and usage.

- The website is attractive and functional. The data are easy to find and navigate and the system's responses are quick.

The ability to download data layers is an important addition to the functionality. The team has incorporated many data layers. The Biofuels Atlas and Biopower Atlas websites work well, data are downloadable, and queries are flexible and quick. The team has just published the 2015 *Bioenergy Market Report*, useful information for informing industry and policy-influencing stakeholders. This is an important contribution to bioenergy literature.

The key missing piece seems to be recognition of the relationship to other efforts. In particular, the relationship between the BIC and the Bioenergy KDF is not clear. Why should these projects not be handled under a single “umbrella?” BIC appears well managed and capable of incorporating the roles of the Bioenergy KDF under a single project management structure including NREL and ORNL contributors. This would promote efficiency in the use of budget.

PI Response to Reviewer Comments

I appreciate the reviewers’ time in providing thoughtful input and comments. BIC supports the biofuels pages on the AFDC, an EERE website available for more than 20 years. The Biofuels Atlas and Biopower Atlas tools were purposefully designed in Google Maps for ease of use by a variety of stakeholders. The tools provide a multitude of bioenergy and related datasets on one webpage. Usage of the Bioenergy Atlas tools grew by 44% between FY 2015 and FY 2016 as a result of a redesign and outreach. The BIC and Bioenergy KDF tasks both complement and differ from one another. The emphasis of the BIC task is on existing feedstocks and infrastructure data while the focus of the Bioenergy KDF is on forward projections of feedstocks. NREL, with stakeholder input, selects, updates, and maintains data and information available in AFDC, Biofuels Atlas, and Biopower Atlas. The Bioenergy KDF allows users to upload and share bioenergy publications and data with a mapping application focused on showcasing data from the BT report series. Automated methods allow sharing of data between tools.

BIOENERGY KNOWLEDGE DISCOVERY FRAMEWORK

(WBS #: 6.3.0.2)

Project Description

There are many issues in the biofuel supply chain ranging from production to delivery that have to be addressed in order to foster a viable biofuel industry. Infrastructure issues related to generation, distribution, and delivery of biofuels include finding the optimal locations to site biorefinery to minimize cost with adequate availability of feedstock resources nearby. The Bioenergy KDF is a collaborative platform for knowledge creation, collection, curation, and discovery to support DOE's effort to develop a sustainable biofuel industry. The Bioenergy KDF facilitates informed decision making by providing a means to synthesize, analyze, and visualize vast amounts of information in a spatially integrated manner. The Bioenergy KDF enables data harmonization from different sources, serves as a source of authoritative and benchmark data-

Recipient:	Oak Ridge National Laboratory
Principal Investigator:	Aaron Myers
Project Dates:	10/1/2007 - 9/30/2020
Project Category:	Ongoing
Project Type:	Annual Operating Plan
DOE Funding FY 2014:	\$400,000
DOE Funding FY 2015:	\$400,000
DOE Funding FY 2016:	\$250,000
DOE Funding FY 2017:	\$300,000

sets, and provides integrated decision-making capabilities to its stakeholders. It serves as an open platform, leverages collaborative aspect of the internet to catalogue and share datasets and other relevant information. The Bioenergy KDF will also host "apps" addressing different bioenergy related problems. These apps will include techno-economic models, routing models for transportation, and apps for visualizing different feedstock production scenarios.

Weighted Project Score: 7.5

Weighting: For ongoing projects, there is equal weighting across all four evaluation criteria: Approach, Relevance, Accomplishments and Progress, and Future Work.

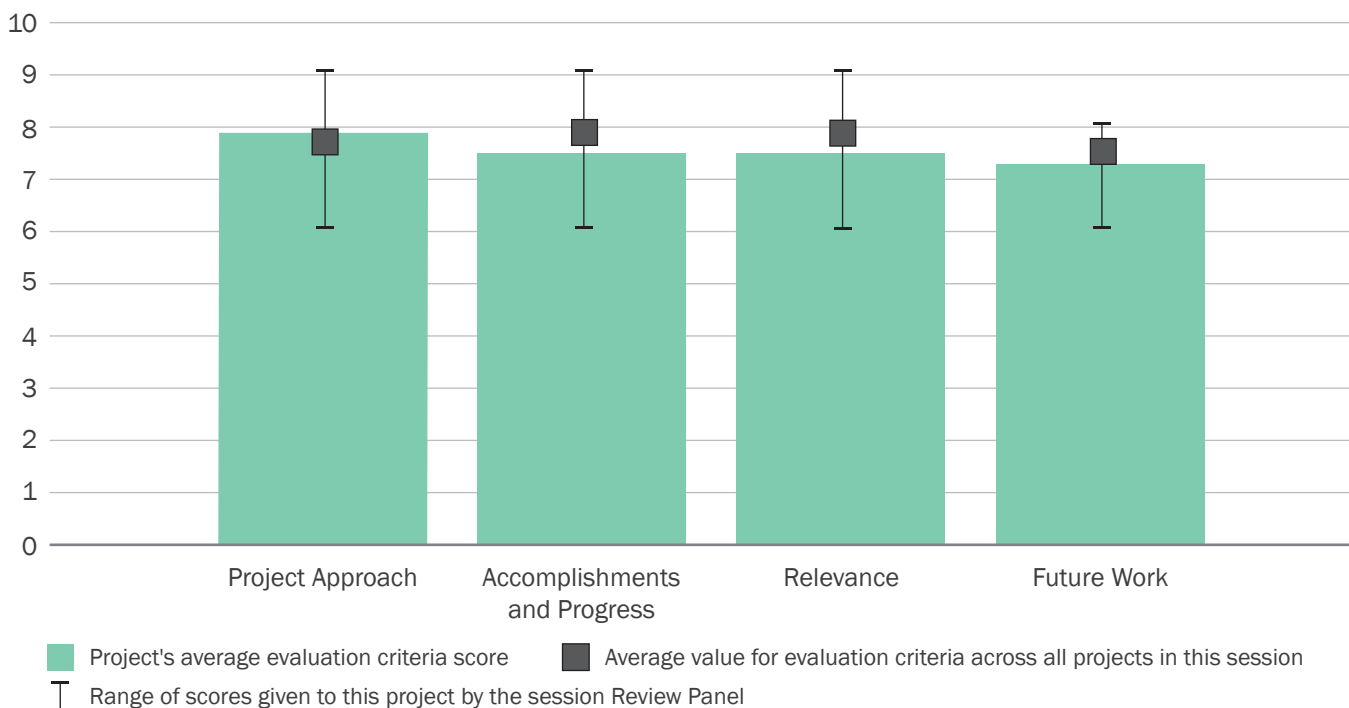

Overall Impressions

- The Bioenergy KDF is designed to be a one-stop shop repository for data and information generated by BETO. It serves to connect researchers, industry, and sponsors and to share information within the bioenergy research community. One of its strengths has been its ability to make high-value data and information easily accessible through an interactive web-based architecture. There is no better example than the work that went into making *BT16* easily accessible. Collaboration and community engagement are the key to success with this project. Progress since the last review included updating the Bioenergy KDF architecture, enabling access to the high-octane fuel study, and releasing *BT16*. The tool appears to work well and considerable effort is made to make the data and the reports as accessible and interactive as possible. It should not come as a surprise that one of the greatest challenges is getting people to use the system. Perhaps if there was some way to incentivize people to use the system as part of their project goals or funding it would be easier to get people to use it. The Bioenergy KDF serves as a single point of contact and the place to go to get things like *BT16*. This can be seen by the spike in users when a major report like *BT16* is released. The Bioenergy KDF serves to enable collaboration across the various programs by providing researchers with access to the tools, data, and information needed to help further research. It also serves to provide a mechanism for the dissemination of a consistent, science-based message. In addition to the scheduled software updates and enhancements, I would encourage continued integration with other data repositories. I also applaud the efforts to update and enhance a legislative library, as this serves an important link between BETO and legislators. I would also recommend increasing the visibility and use of the site.

- The Bioenergy KDF appears to be a necessary component to the larger BETO mission that is often overlooked. Efforts have obviously been deployed to cleaning up the portal and expanding capabilities. Future efforts must be devoted to fostering a viable user community if this effort is to achieve its potential.
- We were asked to review several types of projects, and the standards we employ in evaluating ones like this, where the objective is to organize and present information, will differ from those we use in others, in which the objective is to generate information. I do not have particular expertise in this area, and have not been a user of such data. Perhaps the most useful thing I can say is that it is important to continue to use analytical methods to identify events that trigger site usage and develop plans for improvements.
- This appears to be a top-notch dissemination platform. Dissemination of work and tools across all the projects is centrally important to all BETO efforts. It is a high priority for BETO to freely share and promote data sharing as this engages stakeholders and enhances the credibility of all its work.

The main question is how valuable the specific tools and information provided by the Bioenergy KDF are to users. To understand the benefits and how best to maximize them, an identification of the target audience and assessment of user reviews and needs is a priority and should be central to project planning going forward. For example, perhaps users would prioritize certain decision-support capabilities or prefer the ability to obtain more underlying data to run analyses with their own assumptions.

To understand costs, an assessment of the longer-term maintenance needs and potential options to ensure sustainability would be valuable, including options to scale up the site to be a broader platform across, and potentially beyond, BETO. To the extent

possible, technical administration and design of different dissemination platforms across project should also be integrated to reduce any duplicative costs.

- The Bioenergy KDF is a useful repository of research from BETO. However, it is limited in its coverage and usefulness to stakeholders. Moving forward, the project should work with stakeholders to more clearly establish how the project adds value and then focus efforts on key contributions the Bioenergy KDF can make that would not happen otherwise.

If this project goes forward, it is important to distinguish the Bioenergy KDF from other data repositories. If the distinguishing factors are visualization capabilities that are costly to create and maintain, it is worth considering whether they are worth pursuing and to answer that question based on expressed stakeholder needs.

To justify the project moving forward, it is important to better track what users are visiting the site for and to determine what features and data are most useful.

PI Response to Reviewer Comments

- Thank you for your feedback.

CEMAC: MARKET ANALYSIS OF BIOMASS-BASED CHEMICALS SUBSTITUTIONS—NREL

(WBS #: 6.3.0.5, 6.3.0.6 and 6.3.0.7)

Project Description

CEMAC performs high-impact analysis, benchmarking, and assessment of supply chains and manufacturing for clean energy technologies that can be applied by decision makers to inform R&D, policy, and investment directions. Established in 2015, CEMAC is housed at NREL and operated by the Joint Institute for Strategic Energy Analysis. CEMAC engages DOE, U.S. federal agencies, national laboratories, universities, and industry to promote economic growth and competitiveness. This collaborative project, which includes ANL, NREL, and PNNL, is conducting a global supply chain and market

Recipient:	Argonne National Laboratory, National Renewable Energy Laboratory, Pacific Northwest National Laboratory
Principal Investigator:	Maggie Mann
Project Dates:	10/1/2015–3/31/2017
Project Category:	Sun-setting
Project Type:	Annual Operating Plan
DOE Funding FY 2014:	\$0
DOE Funding FY 2015:	\$550,000
DOE Funding FY 2016:	\$425,000
DOE Funding FY 2017:	\$0

analysis for chemicals synthesized from lignocellulosic biomass. The project goal is to elucidate the manufacturing costs and value-added along the supply chain, U.S.-specific competitive advantages, and the potential market impact of biomass-derived chemicals.

Weighted Project Score: 8.1

Weighting: Approach 25%, Relevance 25%, Accomplishments and Progress 50%

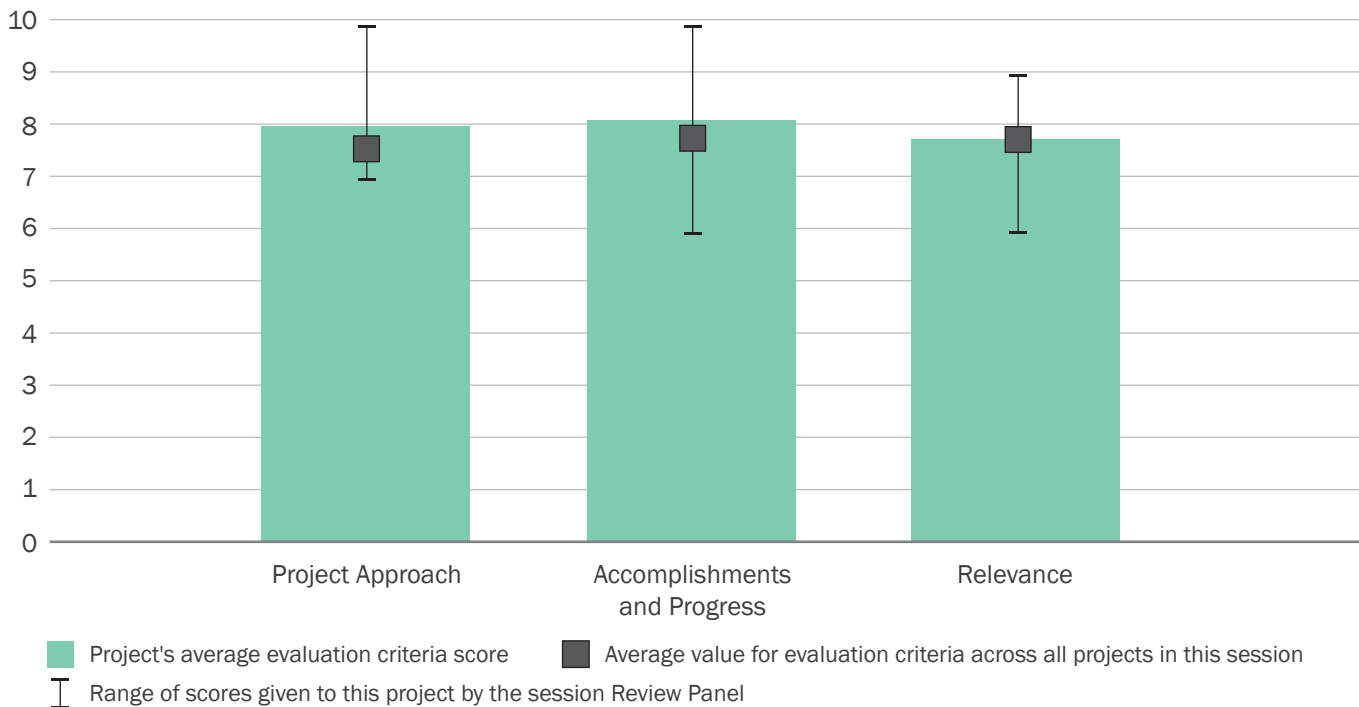

Overall Impressions

- The goal of this project was to develop analyses and methodologies to understand the manufacturing costs and potential market impacts of lignocellulosic-derived chemicals with the intent that these results be leveraged by decision makers to inform investment strategies, policy, and other decisions necessary to promote economic growth and competitiveness in a bioeconomy. The project was well managed with a strong team of collaborative partners from academia, the national laboratories, and industry. Monthly calls and clear deliverables helped to keep the project focused and productive. In an effort to evaluate the production of chemicals from biomass, the team evaluated over 170 bioproducts using a range of metrics including economics, markets, and sustainability drivers. These bioproducts were down-selected using the set of screening metrics the team developed. From these, three case studies were performed to evaluate economics, U.S. and global markets, and supply chain needs. The findings were outlined in a detailed report of the study. Preliminary results showed that 20 of the products could offer significant benefits. Consistent with my own findings, the team identified scale-up risk and accessible supply chains as important criteria when considering bioproducts. This project aligns well with BETO's goals to develop a deeper understanding of bioproduct markets, economics, and sustainability. The study went beyond just techno-economic considerations to include market drivers and sustainability metrics in evaluation. This work is very important and should be continued as a part of other BETO projects. Biobased chemicals and bioproducts could serve as enablers for the biofuels industry. Already, as the study found, there are examples of bioproducts being produced at a commercial scale. These products could help mature the biomass supply chain and provide initial wins for the bioeconomy. While this is a sun setting project, many questions remain. I would recom-

mend including this work in other BETO projects as appropriate.

- The project seems to have achieved its objectives. Outputs were reasonable. Integration with other efforts appeared to be reasonable and well thought out.
- My two main concerns with this project are as follows: (1) Because it was difficult to find many chemicals that might be treated as case studies, it is hard to know how representative and transferrable the results of the exercise are. (2) Without knowing more about the nature of the processes and products of the petrochemical industry, it is hard to know how the growth of alternative, biologically derived chemicals might impact the production and sales of environmentally harmful petrochemicals.

I should hasten to add that the second concern likely arises as much from the limitations of this reviewer than from any fault of this project. Both concerns may point to opportunities, however, to expand the scope of the analysis, as well as of reports of its results.

- This seems like a potentially seminal project for understanding the U.S. bioproducts opportunity. The project has focused on the technical analysis but would benefit from stepping back and looking at the big picture in terms of the potential economic and environmental benefits. Key questions are: What and how large are these potential benefits and what are the trade-offs with other uses and approaches to achieve them? This would help identify the potential value of next steps. The publication of the final report is important, including finding ways to disseminate through the Bioenergy KDF, BIC or other platforms.
- This is a strong, well-managed project. It is also important that the data produced for this project are released in a manner suitable for incorporation in future studies. The research questions were clearly

defined and the approach is adequate and appropriate. It would be helpful to more clearly define the metrics by which the successes of the project are measured.

The project produced a large amount of results/information. It is important that these results are

documented in peer-reviewed reports and articles. Could the project team comment on how this will be done following project sunset?

PI Response to Reviewer Comments

No official response was provided at the time of report publication.



STRATEGIC COMMUNICATIONS

INTRODUCTION

Strategic Communications is a vital crosscutting component of the Bioenergy Technologies Office's (BETO's or the Office's) portfolio. The bioeconomy must involve successful, coordinated operations among many industries and sectors of the U.S. economy, from biomass producers to end-use markets and finally to the consumers. Effective stakeholder collaboration and communication play important roles in addressing non-technical, cultural, and social barriers to bioenergy adoption and utilization. A strong network of coordinated, informed

individuals among public and private sectors is essential for the long-term success of the bioeconomy. BETO's Strategic Communications portfolio addresses these needs and has evolved significantly to accomplish the following:

- Help strengthen stakeholder relationships
- Improve the quality of stakeholder collaborations
- Drive the development of a well-trained bioeconomy workforce
- Increase awareness of bioenergy and BETO's role among the general public.

OVERVIEW

Strategic Communications consistently creates and curates relevant and valuable content to assist stakeholders to better understand and embrace new concepts, technologies, and products. Informing targeted audiences about BETO's work and promoting the benefits of sustainable bioenergy strengthens support for supplying and consuming bioenergy products to develop a thriving bioeconomy. Strategic Communications (1) engages a broad range of stakeholders in meaningful collaborations, (2) promotes the accomplishments of Office-funded advanced technologies, (3) increases consumer awareness and acceptance of biofuels and bioproducts, and (4) amplifies the expansion of bioenergy production and use across the bioenergy supply chain.

Strategic Communications promotes outcomes of research and development (R&D) technologies developed in the Office's program areas—Feedstock Supply and Logistics, Feedstock-Conversion Interface Consortium, Advanced

Algal Systems, Conversion R&D, Demonstration and Market Transformation/Advanced Development and Optimization—and in the crosscutting area of Analysis and Sustainability.

In addition, Strategic Communications focuses on identifying and addressing nontechnical barriers to bioenergy adoption and utilization in an effort to reach full-scale market penetration. This is accomplished by educating audiences and increasing awareness through a combination of internal and external communication methods. BETO aligns its messaging and outreach with the U.S. Department of Energy's (DOE's) and Office of Energy Efficiency and Renewable Energy's (EERE's) mission, strategic goals, and vision. Successful external communications will improve the flow of accurate and consistent information throughout the DOE community and ultimately result in crosscutting collaborations, increased market transformation, and mission and vision alignment with other DOE transportation programs.

Successful coordination of internal and external communications strategies will improve the following:

- Knowledge of advanced bioenergy and biomass feedstocks R&D
- Funding opportunities
- Technologies
- Policies
- Collaborative efforts to educate stakeholders and improve market penetration
- Dissemination of accurate and consistent information, which dispels inaccurate information clutter while also diffusing conflicts and conflicting messaging
- Understanding of the economic, environmental, social, and U.S. competitive advantage benefits of bioenergy as a viable alternative and complement to fossil fuels.

In response to misconceptions about bioenergy, the Strategic Communications team focuses on amplifying facts, based on sound science about bioenergy; highlighting BETO and partnership successes; and identifying and addressing market and other non-technical barriers to bioenergy adoption and utilization.

Strategic Communications activities are relevant across the full bioenergy supply chain, from biomass production to end use. For activities throughout the supply chain, BETO disseminates sound science and increases awareness of the economic, environmental, social, and cutting-edge R&D that can give the United States a competitive advantage in the bioenergy industry.

Target audiences include scientists, engineers, researchers, industry, investors across the bioenergy supply chain, policymakers at all levels of government (including members of Congress and their staff), DOE staff, educators and students, members of rural and farming communities, and the general public, who are potential users of biofuels and bioproducts. These key audiences

vary greatly in their level of understanding and opinions about the benefits of sustainable bioenergy. Strategic Communications' efforts include distributing technical and non-technical information to internal and external stakeholders through both traditional and digital channels. These channels include, but are not limited to, website content, social media (Facebook, Twitter, and LinkedIn), conferences, and other events.

Strategic Communications Support of Office Strategic Goals

Strategic Communications supports BETO's overall goals of strengthening stakeholder relationships, improving the quality of stakeholder collaborations, and increasing awareness of bioenergy and BETO's role among the general public and new stakeholder groups.

The Strategic Communications Portfolio's strategic goal is to support and enhance the Office's mission by conducting outreach to target audiences to promote R&D successes achieved through Office funding and to promote opportunities for, and benefits of, sustainable bioenergy production. Strategic Communications highlights the role that a thriving bioeconomy plays in improving economic and community stability, spurring innovation, and achieving U.S. competitive advantage in renewable energy.

Strategic Communications Support of Office Performance Goals

Strategic Communications goals include sharing the Office's messages and technical accomplishments with a broader range of audiences, helping to increase awareness of and support for its research, initiatives, and technologies. Reaching the Office's goals also means a higher potential for new partnerships where more entities may apply for the Office's competitive funding opportunities, allowing for the advancement of existing technologies and the initiation of new, innovative technologies.

Ultimately, Strategic Communications allows for a faster, more effective dissemination of bioenergy-related information to accelerate the growth of the bioenergy industry. It also enhances government accountability by transparently sharing with the public the technical progress that the Office is making toward its goals.

Strategic Communications strives to accomplish the following performance goals:

- Increase awareness of and support for the Office’s advanced biomass R&D and technical accomplishments, highlighting BETO’s role in achieving national renewable energy goals
 - From 2016 through 2022, create and execute an annual communication strategy that incorporates synchronized messaging through the DOE national laboratories and other collaborative networks to highlight the Office’s contributions to developing of new technologies and key milestones
 - From 2016 through 2022, continually develop and implement Office messaging that provides clear, consistent, and accurate information about bioenergy and the industry. The messaging will be aligned with DOE’s and EERE’s missions and with individual Office program goals.
- Educate audiences about the environmental and economic opportunities and social benefits of biofuels, bioproducts, and a growing bioenergy industry
 - From 2016 through 2022, in conjunction with EERE sustainable transportation offices, develop and implement initiatives to raise awareness about the benefits of sustainable transportation technologies. Leverage these partnerships to educate new stakeholders on the benefits of biofuels and bioproducts.

The specific Strategic Communications milestones under investigation are:

- By 2017, develop a series of stakeholder-specific educational tools to improve understanding of the economic, environmental, and social benefits of participating in the bioeconomy within the agriculture, algae, forestry, and investment communities
- By 2017, establish at least two new channels of communication with policymakers, including notification of new state and local initiatives, informational briefings for the administration and congressional staff, and the amplification of state fact sheets detailing BETO activities
- In 2018, establish a requirement for all funding awardees to develop and implement a communications plan to disseminate results and impacts of BETO-sponsored projects
- By 2018, sponsor two to four annual stakeholder information and networking sessions for identifying challenges, barriers, opportunities, and educational initiatives
- By 2020, amplify existing initiatives and implement two new education and training programs to match the growing number of bioenergy industry workers
- By 2020, establish vibrant and effective stakeholder engagement initiative coordinated within and between DOE, the U.S. Department of Agriculture, U.S. Environmental Protection Agency, and other federal agencies to enable joint initiatives to advance and expand the U.S. bioeconomy
- By 2022, establish annual educational materials and outreach efforts to inform the general public and key stakeholder audiences about the challenges and opportunities of a thriving bioeconomy
- By 2022, enhance public awareness and market interest in advanced bioenergy by collaborating with a highly visible organization to promote a successful technical and/or communications project and its outcomes

- By 2025, assess progress on developing education and consumer behaviors and refine strategy as needed
- By 2025, have robust workforce development programs in place to support a group of well-trained workers to fill the demand created by a growing bioeconomy
- By 2025, establish three to five collaborative initiatives with corporate and nongovernmental organizations to assist in the continued growth of a sustainable bioeconomy
- By 2035, evaluate the effectiveness of unified communications and outreach efforts and refine them as needed.

THE EVOLUTION AND FUTURE DIRECTION OF BETO'S COMMUNICATIONS PORTFOLIO

Prepared by the BETO 2017 Peer Review Steering Committee

The BETO 2017 Peer Review Steering Committee recognizes strategic communications and stakeholder engagement as a vital area of BETO's work. To provide an evaluation of the Strategic Communications portfolio, the Steering Committee viewed an overview presentation from the Strategic Communications director and participated in a targeted discussion with BETO leadership about the cross-cutting initiative's past experiences and future goals.

Key Accomplishments:

- Significantly increased viewership of BETO publications, news releases, and other traditional content through digital channels, as well as improved understanding of bioenergy for non-technical members of the public via BETO's external new media platform
- Launched BETO's education and workforce development portfolio to improve the growth and competitiveness of the domestic bioeconomy workforce. Key activities include the Bioenergy Career Map and the BioenergizeME Infographic Challenge.
- Enhanced coordination among key federal, national laboratory, industry, and academic stakeholders through cooperative working groups, amplification

of events aimed at key stakeholders, and new strategic partnerships.

Strengths

The Steering Committee appreciates the organization and thoughtful effort that is represented in the Strategic Communications portfolio. It appears that BETO is making strong efforts to partner, coordinate, and share with many audiences. Many of the products that have been developed are of high quality.

It is also clear that the Strategic Communications team has a can-do, positive attitude, particularly in dealing with limited budgets and bureaucratic processes. A strength is that the team operates efficiently through partnerships and collaboration by working with other agencies and entities who are involved in communicating similar messages. There is additional strength within BETO derived from the great network of partners, laboratories, and performers involved in BETO's work. This network could perhaps be better leveraged if the terms of funding opportunity announcements (FOAs) or annual operating plans (AOPs) were written to encourage the use of the laboratories' or performers' communication resources to disseminate the results of the Office's investments. Laboratories are required to provide BETO with a project-related success story each reporting quarter. Successful laboratory work/advancements should be publicly communicated to the greatest extent possible.

One great strength is the foundation of knowledge and data that BETO has already developed. There is a great

story to be told, and it is one that gets better every day. The focus on myth busting is important, and BETO clearly has the objective information needed for this task. However, the amount of effort needed to refute incorrect information is an order of magnitude larger than the effort needed to disseminate it in the first place (Brandolini's Law). Therefore, a more proactive messaging effort from BETO to frame the dialogue, as opposed to reacting to it, would be a more efficient and impactful use of limited resources. Further, changing overall societal perception seems implausible given the limited resources available. As such, it may make sense to strategically target BETO's communication efforts at those who are most directly involved in potential purchasing and financing decisions within the bioenergy industry, rather than tackling misperceptions within the general public.

The expansion of the digital media portfolio in recent years is a strength. Increased email news blasts and announcements have been very well-noticed and received. The digital communication strategy for sharing success stories, FOAs, and program, industry, and partnership news is laudable and leverages the ability of social media to amplify the Office's messages to a broader audience.

The Steering Committee notes that the development of BETO's education and workforce development portfolio is a very important piece in the puzzle of developing the bioeconomy. Educating educators is a necessary focus, and a focus on jobs will resonate in the current political climate. However, as mentioned in the main Steering Committee report, it is unclear whether a technically oriented program such as BETO is properly positioned to lead this effort. We recommend that BETO works closely with appropriately experienced partners that have workforce development as a key component of their mission to ensure a successful program.

It is also noted that BETO events are high quality and well-received.

Limitations

The major limitation of the strategy is that it lacks a focused and concise goal. The strategic goal, as documented in the *Fiscal Year 2017 Strategic Communications Plan*, is righteous and certainly something to strive toward. But, in itself, it captures the challenge—it is multi-pronged, enumerating various activities supporting various outcomes. A simpler, punchier vision is needed, and an effort to develop a "brand" might be useful in focusing the strategy. "Branding" of the bioeconomy to aid the public in recognizing the presence, strength, value, and diversity of bioeconomy activities (generally) may hold value.

The Steering Committee appreciates the difficulty in defining a clear and focused communications strategy and struggled reaching consensus recommendations as to how communication efforts should be prioritized, particularly to the extent to which BETO should focus communication resources on public education. The lack of consensus on this topic has led to individual recommendations either deemphasizing or strengthening public education projects within the overall portfolio. While the individual suggestions may be somewhat contradictory, they underscore the need for greater discussions surrounding the goals of BETO's communications strategy. The overarching recommendation for the communications portfolio is for BETO to clearly articulate (1) priorities regarding the specific audience(s) the Office wishes to reach, (2) the Office's definition(s) of success, and (3) the boundaries of what should not be included or emphasized. The Steering Committee believes that having a stronger and deliberate Strategic Communications focus will ultimately be worth the time commitment and allow the commendable efforts in this area be even more effective.

It is difficult to measure impact. However, this program must develop some better measures of whether they are achieving any of their various ambitious goals. For example, one of the stated goals is "an improved understanding of bioenergy for non-technical members of the

public.” How many members of the public have to be reached to make a difference for the bioeconomy? What is the current level of awareness, and what particular communication gaps need to be filled? How well does BETO messaging impact/affect non-technical public awareness? Without clearer measures and analysis of communication needs, the program risks being of low impact. The playbook developed by BETO BioComms is a good start in this direction, although more sophisticated statistics than just “views” would be helpful to gather and analyze.

One limitation is in getting industry to adopt BETO’s R&D findings and for the Office to show how its investments in R&D, coupled with effective communications, lead to more success in the bioeconomy. It is good that BETO has identified industry as the most important customer that is looking to have technical information summarized. The key now will be to ensure that the materials and channels will effectively target this group.

Lastly, a significant limitation is the sluggish approval process inherent in any public communications, and especially in federal contexts. In part because of this, there is less public communication than would be ideal for BETO. In particular, it is important to continue to improve outreach and education with the largest generation today: millennials. As they get a great deal of their casual information digitally, expanding digital messaging is appropriate and important in terms of public comprehension and support for this work.

Funding Allocation

The first step in addressing allocation of funding should be a prioritization of goals, something which appears to currently be lacking. There is a need to prioritize efforts at three different levels:

1. What are the most-important, high-level objectives (e.g., maintain/grow funding, garner public support, or increase inflow of innovation)?
2. Which stakeholder groups are most influential in terms of the identified top-priority outcomes?

3. What activities should be prioritized to target top stakeholders to influence them to support the priority high-level objectives?

Another element of understanding and managing the Strategic Communications budgets is developing measures of cost/benefit for various activities. Without any clear metrics of impact/outcome it is very difficult to effectively manage a budget and make prioritization decisions among alternatives and to determine level of investment in any given activity. We would highly encourage the Strategic Communications team to develop robust metrics that can guide budget/investment decisions.

That said, the Steering Committee can provide some preliminary feedback on our views of current funding allocation. The area of industrial communications is absolutely critical and deserves more funding. If BETO results and findings are not widely disseminated in highly accessible forms, the investment in R&D is wasted. This area received far less coverage in the presentation than the workforce and education elements, but it is far more critical. The BioComms work is also critical. It looks like BETO is appropriately engaged in coordinating and messaging to DOE and legislative stakeholders. In the rapidly evolving federal environment, it is essential to spare no effort in documenting impact and defining key messages.

One area to consider would be an expansion of the public education effort. Buying ads on social media would be an inexpensive method of expanding educational outreach to the public. BETO does not have its own Facebook, Twitter, or Instagram presence. It may sound atypical of government, but these are important venues to consider, as they are potentially very high-traffic and free. Social media does not come without risks, however, and poorly framed messages could spread virally. Careful message management would still be important. We further recommend additions and improvements to the website and other digital media.

Adding a requirement to share the communication workload as part of the FOA grants winners is a smart idea. If grantees were required to synopsise their successes in a video or infographic and push it out on social media and their websites, this would increase BETO outreach in a rather effortless and less-cumbersome manner than is currently available. Even if it is messaging that the Office creates and they (e.g., the laboratories or universities) retweet or share it (as well as distribute your printed material), all of this has the potential to expand outreach and public knowledge of BETO's great work. One approach to put even more ownership back on the researcher/program would be to ask for a communications plan with each project and have it reviewed. Sometimes being forced to consider the communications plan at the beginning of a project will lead to changes in project design and execution, all to get a better impact at the end.

Collaboration and Partnerships

Based on what was shared regarding the participation of the Strategic Communications team in quarterly reviews, and in working with the technology managers, it sounds like the right channels are open to allow access to the kind of communications content that is needed. There is, of course, a trade-off between efforts to integrate with other programs, and the available bandwidth to generate communication output.

If an allocation decision is needed, we would suggest that if there is one program within BETO that the Strategic Communications team should spend the greatest amount of time coordinating with, it would be Analysis and Sustainability. The output from that team gets to the key message that needs to be communicated outside the confines of BETO: What are the societal benefits of bioenergy?

That said, the near-term focus within the Strategic Communications team should be somewhat more inwardly focused: What is BETO or the bioeconomy's brand? What are the top priorities in terms of stakeholders and

outputs? Only after those questions are answered should the resources of the Strategic Communications team be deployed to gather the collateral from within BETO to support the priority messages.

One place where coordination may be enhanced is in the actual development of key messages and detailed scoping of stakeholders/audiences. These are two things that BETO program managers would have key insights into, and it was not clear that there is a process to engage them in developing messaging or helping to identify stakeholders.

One suggestion is in increasing coordination with the Clean Cities program in EERE's Vehicle Technologies Office on biofuels deployment. Clean Cities partners with MotorWeek's long-running weekly show on PBS, which is produced by Maryland Public Television. The host, John Davis, is a close ally of the Clean Cities program. The show has produced many informative segments on biofuels and bioenergy. In some cases, the episodes go beyond covering biofuel end use in vehicles and discuss fuel production. There is clearly an opportunity to develop a future segment exploring a large-scale biorefinery or discussing the Co-Optimization of Fuels and Engines initiative.

Education and Workforce Development

Regarding science, technology, engineering, and math (STEM) education efforts, a strong communications strategy seems to reach the K–12/science educator community. The products appear to be well-defined and presented (for example, BioenergizeME). However, it is unclear how the Strategic Communications team identifies/connects to the education community. If the outreach is entirely passive (information available on a web page), then the impact may be minimal. While much of the material provides hyperlinks to other content providers, this begs the question—what is the purpose of BETO's website? Do users have a hard time finding the scattered information that has already been developed,

and therefore, the purpose is to provide a central clearing house? Or is there some gap in available material/content that needs to be filled by BETO, and therefore, the purpose is to disseminate new information? Federal STEM activities are already engaged in getting K–12 students interested in science. BETO’s investment here is unlikely to lead to any further success of the bioeconomy.

Workforce development is an interesting topic that seems to be stretching Strategic Communications into an entirely new area. Basic information about job opportunities/career paths could be a BETO Strategic Communications mission; however, developing workforce training materials, curricula, and recruitment materials seems like it is outside of BETO’s core mission. These are things that should be done by community colleges/universities and the educational/vocational training community. The Strategic Communications team should explore this part of their strategy very carefully and engage with appropriate external partners to lead these efforts. BETO’s career profiles are just mirroring the U.S. Bureau of Labor Statistics’ (BLS’) information, and BLS is the recognized go-to source for career service people, like high school counselors and job placement coordinators. BLS already has a “Careers in Bioenergy” report online. BETO’s efforts may be duplicative, and there are many other entities that also have a vested interest in addressing workforce (e.g., industry and academia). We suggest partnering with existing federally supported academic partnerships, such as the U.S. Department of Agriculture’s Coordinated Agriculture Projects on bioenergy. Coordinated Agriculture Projects already has a mandated extension/education component and could share objectives in this regard with BETO. Another possible collaborator would be the U.S. Department of Transportation’s University Transportation Centers.

Perhaps a stronger goal for BETO and workforce development is to identify and address gaps in the bioenergy workforce development sphere. For example, BLS data draw on Renewable Fuels Association and National Biodiesel Board reports on jobs as a function of units of

production. Improving these kinds of data would be a value-added BETO workforce development role.

Communication Messaging

The Steering Committee perceives an opportunity to more clearly identify and define what key messages should be prioritized. As mentioned above, decisions around messaging need to flow from a concerted prioritization exercise; otherwise, efforts will be too diffuse and lack impact. Developing a “brand” would help define the key messages, as will focusing down to two or three messages that will stick in peoples’ minds. One challenge noted by the Strategic Communications Team is “inconsistent internal messaging,” so agreement internally as to what are the key points to get across, and to whom, is clearly a necessary first step.

The Strategic Communications plan presentation at the 2017 Project Peer Review gave some indications of effectiveness, using Facebook and Twitter views as measures of impact. The Steering Committee cautions against using simple views as a measure of impact. State-of-the-art communications practices, such as those used in commercial marketing, use big data and analytical tools, along with real-time social media data mining, to gauge effectiveness of messaging, audience adoption, and acceptance of information. Industry uses these tools to know with some certainty that its communications are reaching the intended audience *and* having the intended effect. For example, if/when BETO releases a public service ad about the benefits of the bioeconomy, how does the social media world react? Are external responses to the BETO message positive or negative? Should the initial communication be modified to enhance impact? A state-of-the-art communications/marketing strategy would employ that kind of technology to proactively manage the communications investment for maximum return. Clearly, such sophisticated and resource-heavy analyses are unlikely to fit within tight BETO budgets, but directionally the guidance and best practices are there for modelling upon.

The target audiences that were addressed in the presentation are well-thought-out. However, simplifying scientific messaging so that it is readily understood by the average public audience without compromising the veracity of the message is a difficult task. Current examples are well-thought-out and messaged, such as “One billion tons of biological material—that’s enough to fill a 16-foot flatbed truck stacked roughly up to the moon!” Some additional ideas include adding a kid’s educational page to the website that is interactive and very visual, or something teachers can use in a lesson plan along the lines of a carbon footprint calculator comparison, but with bioenergy benefits.

The creation of smart visuals for the public that compare and contrast oil and bioenergy would be useful. Such content could include benefits and problems, such as greenhouse gas impacts, jobs, domestic security (or insecurity), air pollution (or cleanliness), water pollution (or cleanliness), and health problems and costs. People in general do not see the true costs of energy—if they did, this would change some of their minds.

Stakeholder Audiences

The six identified stakeholder groups are all appropriate. One group that might be missing is civil society thought leaders, for example, nongovernmental organizations or think tanks. This type of audience can be highly influential with policymakers and the general public.

Reaching all of the stakeholder groups effectively could be difficult, especially with limited resources. For establishing the commercial activity of the bioeconomy, the most critical stakeholder group would have to be industry. It appears that BETO focuses communications efforts on this group—an appropriate prioritization. In many ways, achieving BETO’s mission hinges on getting successful integrated biorefineries established. A stated goal of BETO Strategic Communications is to enable “greater knowledge transfer between researchers

and industry.” This bears more planning and analysis; it is a critical task, yet there do not appear to be well-defined approaches or in-depth understanding of the communications problem. Certainly, the technical information generated by the efforts of BETO-funded research is available, but although the technical content is there on some specific websites at Oak Ridge National Laboratory or the National Renewable Energy Laboratory, it would be beneficial if it were easier to find. BETO’s Bioenergy Knowledge Discovery Framework offers a powerful information portal and research collaboration platform, though not many people know about it, and its user base is small.

The overview given during the Project Peer Review identified in general terms why some groups were important to engage, but details were necessarily lacking. For example, in developing effective communication to industry there are wide differences among various segments (e.g., operations/management and R&D). Technology blogs seemed to be the primary product offered to meet all these needs, which may not be the most impactful tool for all industry interests. Marketing strategies are usually based on thorough market/customer analysis and segmentation. It seems that more information about your various stakeholder groups is needed. However, at the Program Management Review, more details were provided on the tools that will be used, including Bioprose and BioComms. This specificity is good to see, although further details need to be elucidated on the specific messages that are to be communicated through these channels.

There are two stakeholder groups that should not be overlooked, even as a focus on industry audiences is made. The general public and policymakers are two forms of BETO’s key constituency, providing the license to operate and the means to operate, respectively. If BETO is unable to directly advocate to the policymakers, then a clear strategy to work indirectly through partners or target political constituencies is needed.

STRATEGIC COMMUNICATIONS PROGRAM RESPONSE

Strengths

The BETO Strategic Communications team recognizes and appreciates the value of enhanced coordination and collaboration among the key federal, national laboratory, industry, and academic stakeholders that are working to develop the bioeconomy. Collaboration creates a fuller understanding of the challenges and potential of this industry among stakeholder groups while maximizing funding and available programmatic resources. The federal agencies and industry partners involved in the bioenergy space have a long tradition of working together. One prominent example is the Biomass R&D Board, an interagency collaborative composed of senior decision makers from federal agencies and the White House, co-chaired by the U.S. Department of Agriculture and DOE.

In February 2016, the Biomass R&D Board released the Federal Activities Report on the Bioeconomy, which outlined the vision for increasing biomass utilization three-fold by 2030, while also maximizing economic, environmental, and social benefits. Soon after followed development of the Biomass Research and Development Initiative, whose goal is to address challenges to and opportunities for achieving this vision. Through the joint efforts of the participating agencies, the federal government has substantially improved the dissemination of information relating to the emerging bioeconomy by adopting a comprehensive, common federal approach to craft a concise, consistent narrative, rather than relying on isolated releases of information by each office. The Strategic Communications team has capitalized on these efforts, using these narratives to frame the dialogue surrounding the bioeconomy. These key messages have been shared widely with our larger partner network (e.g., national laboratories, nonprofits, and industry partners) to help communicate a shared vision of the benefits of the bioeconomy.

This network has also been instrumental in sharing information on new, commercially relevant BETO-funded technologies that can help de-risk industry investments, as well as the potential socioeconomic impacts of publicly funded research (e.g., creating new useful products, new jobs, and sometimes new companies). However, we agree that we can continue to enhance efforts to leverage these resources using a more standardized approach. Future FOAs and national laboratory AOPs could contain additional guidelines on utilizing their own in-house communication resources to disseminate the results of the Office's investments.

In addition to enhancing collaboration and coordination, we are proud of our digital media efforts—which encompass websites, email, blogs, mobile communications, video, and social media. Advances in digital media infrastructure and capabilities over the last decade have changed how stakeholders communicate and gather information. Now more than ever, people want on-the-go access to engaging information that piques their interest, as well as the opportunity to participate in the conversation as it evolves. Adopting an integrated digital media platform is, therefore, an essential component of our overall strategy. In fact, the use of digital and social media has increased the reach of our communications efforts, allowing us to target specific audiences and develop more meaningful interactions with BETO stakeholders. As digital and social media are increasingly more accessible to individuals working in the bioeconomy and as policymakers and industry are increasingly more engaged with and paying attention to these mediums, stories of innovative technological breakthroughs have the opportunity to be heard. Moving forward, we will continue to learn and improve how we use digital media to share information.

Lastly, education and workforce development has emerged as a priority area for developing the bioeconomy, and BETO's Strategic Communications team has begun to address this need. In 2016, the Biomass R&D Board's Operations Committee held five bioeconomy

listening sessions in which over 400 stakeholders across the United States identified the need for a strong and capable workforce as one of the primary challenges to expanding the bioeconomy. We appreciate, however, that as an organization primarily dedicated to R&D, efforts to expand education and workforce development should not rest solely on BETO's shoulders. Working strategically with partners who are invested in building a pipeline for sustained job growth, we will continue to determine the most impactful role BETO can play in this space. We will also continue to share our tools and resources (e.g., the Bioenergy Career Map) to increase awareness of the varied career opportunities available across the bioeconomy value chain.

Limitations

As the BETO Strategic Communications portfolio evolves, we will continue to fine tune our strategic goal to be more concise, outcome-oriented, and inclusive. Given limitations in resources, the Strategic Communications team is currently revising its strategic plan to focus on areas where stakeholder engagement can have the biggest impact on BETO's overall strategy and operations. Our goal moving forward is to streamline our process to enable more cost-effective stakeholder engagement activities. Learning from our previous communications efforts, we will reevaluate our performance indicators to measure the value of investing in specific engagement activities to help focus the current strategy. We also plan to work in close concert with the Biomass Research and Development Initiative to map out and prioritize stakeholder groups, delineate agency strengths in the communications sphere—based on internal priorities and available resources—and identify the right mix of engagement tactics for specific target audiences.

Establishing clear, specific, attainable, relevant, and timely measures of success has and will continue to be an integral part of this process. As a government entity, there are certain limitations inherent to evaluating success (e.g., limits to number of surveys or collecting

certain types of data). However, BETO's Strategic Communications team developed a Communications and Outreach Tracker as a workaround. This tool captures how and where communications products are disseminated, the high-level demographics of BETO's readers, which outlets pick up certain topic areas, and the response that BETO communications elicit in the digital landscape. This ultimately allows the team to examine each communications product individually and use the tool to prioritize stakeholders and understand their needs and interests, define the activity metrics, determine the outcome metrics, and finally, use the data to make strategic decisions.

The BETO Strategic Communications team also agrees that there is a clear need to “brand” the bioeconomy to help aid the public in recognizing the presence, strength, value, and diversity of bioeconomy activities. Efforts are already underway to strengthen general awareness among consumers who contribute to the bioeconomy. We are also exploring ways we can brand the bioeconomy with our in-house team of public relations and legal specialists.

Budget

The BETO Strategic Communications team operates on a shoestring budget. As such, we must be strategic in selecting areas to prioritize funding. Most of our resources are directed toward high-impact projects managed through the national laboratories' AOPs. BioComms, the Bioenergy Career Map, and the BioenergizeME Infographic Challenge are several examples of projects that enable us to increase and expand communications pipelines by leveraging laboratory communications resources.

- BioComms is a collaboration of national laboratory and BETO communications professionals and laboratory relationship managers to streamline resources and knowledge, share information, and promote successes. It has served as a vehicle through which key BETO communications messages are amplified

and shared with important stakeholders, as well as a network to receive and share high-level impacts of BETO-funded work. Since many of the laboratories work and partner with industry professionals directly, this project has also enabled BETO to have greater access to this key stakeholder group.

- The BioenergizeME Infographic Challenge and the Bioenergy Career Map AOPs provide a similar function. Both have been leveraged to increase awareness of the bioeconomy more broadly. The Challenge engages students, educators, and the general public to be better consumers of energy information and to dispel myths they may encounter. The Bioenergy Career Map also engages a broad range of stakeholders to provide awareness of the diverse career pathways that are available in the bioeconomy.

Our internal analysis indicates that there has been significant interest and impact with these projects. For example, several rounds of the BioenergizeME Infographic Challenge have demonstrated a greater understanding of the evolution of the industry, even among new participants. The student-designed infographics that we received during the 2017 Challenge also reflect the messaging that the Strategic Communications team disseminated over the past year.

Moving forward, we will continue to prioritize our efforts based on the limitations of our budget, focusing on the areas that will highlight the role the Office plays in achieving national goals (e.g., job growth and energy independence), inform stakeholders of the latest cutting-edge science and technology to stimulate the trajectory to market, and educate the public about the many facets of bioenergy and bioproducts across the supply chain.

Internal and External Collaboration

BETO's Strategic Communications team works closely with the Office's program areas—Feedstock Supply and Logistics, Feedstock-Conversion Interface Consortium,

Advanced Algal Systems, Conversion R&D, Demonstration and Market Transformation/Advanced Development and Optimization—and with the crosscutting area of Analysis and Sustainability to inform target audiences about Office accomplishments, strategies, and technologies. Together, we identify the highest-value media and audiences and set strategies, goals, and metrics for targeted outreach. In addition to in-house collaboration, we also work alongside the national laboratories to promote success stories each quarter.

Our team targets the public sector for engagement, which includes a strong sector of educators due to the volume of students these educators reach—on average 3,500 students during each educator's tenure—and the crucial role they play in securing the STEM career pipeline. Career motivation begins at the K–12 level, with the top influences being parents and K–12 educators. Thus, educators serve as an important piece of the puzzle, both increasing energy literacy among future consumers and generating interest in careers that will support the bioeconomy. Given that BETO's primary function is not education but, rather, R&D, we designed educator-focused activities to complement the overall communications goal of reducing non-technical barriers to the bioeconomy.

Therefore, the education and workforce development arm of the communications portfolio has bolstered high-level communications efforts rather than detracted from them. These efforts were not passive, but rather attuned to understanding the educators' perspectives and guided by experts with the knowledge needed to effectively engage educators. After extensive evaluation, we found that these efforts have a high impact among educators and the general public and feed into important internal goals. Using the BioenergizeME Infographic Challenge as an example, metrics indicate nearly 60,000 unique viewers have learned about bioenergy through this program, with many more that are not represented in this figure but have been captured anecdotally. This Challenge is also the primary tool through which we

identify common bioenergy misconceptions and outlets where misinformation persists. This helps us craft key messaging strategies and partner with organizations to help update their information. Ultimately, this feeds into our efforts to brand the bioeconomy, giving consumers access to consistent, factual information.

Another important component of BETO's workforce development efforts is the Bioenergy Career Map. As mentioned, feedback from the listening day sessions indicates that workforce development is a key priority for expanding the bioeconomy. In addition, DOE's 2017 U.S. Energy and Employment Report found that in many energy sectors—including renewable fuels—over 70% of all employers surveyed found it “difficult or very difficult” to hire new employees with needed skills. This feedback indicates that the issue requires further analysis and coordination among key players in the bioeconomy.

Along the continuum of career development (i.e., awareness, exploration, preparation, skills training, and education), BETO is focused on the first level: awareness. The Bioenergy Career Map fulfills this need and allows individuals to discover career opportunities available in the bioeconomy throughout a wide range of sectors. This tool is not simply a carbon copy of BLS' Occupational Outlook, as it provides context on how specific academic concentrations relate to specific needs throughout the bioeconomy value chain. We recognize the capacity of our strong network to provide additional needs throughout the career development continuum and will continue to work with them to serve as a key piece of the puzzle.

Communications Messaging

There is clear consensus among the internal BETO team on the key messages that need to be prioritized. As mentioned previously, these messages have been shared with the Communications team in EERE's main office and throughout our partner networks. This has led to the development of communications products that deliver

a uniform message without compromising the unique story being shared. This consistency has enabled our network to better define the socioeconomic benefits of the bioeconomy. However, there are still many opportunities to share these messages with audiences that can directly impact the bioeconomy. As we move forward, we will prioritize those key audiences to ensure they understand the value and opportunity of this industry.

Although state-of-the-art commercial marketing tools are highly effective for gauging the effectiveness of messaging, audience adoption, and acceptance of information, the team has limited resources to invest in such technology. As mentioned, the Communications and Outreach Tracker provides us with good baseline data to determine whether our communications efforts are effective. Although we do report Facebook and Twitter views, our tracking tool provides us with much more useful information than a simple metric devoid of any strategic feedback. When we use social media platforms to share important messages, we not only track the views, but also how this content is subsequently disseminated and by whom, as well as external responses to the content. We use these data to inform the direction of future releases and to identify potential communications outlets that may be willing to collaborate with us. We see this tool as a good starting point for continuing to build a strong and effective Strategic Communications portfolio.

There is significant value in crafting engaging articles and visuals that pique the interest of a broad mix of stakeholders. Our digital media platform continues to explore new ways to provide information that is easily digestible and impactful. Office videos, interactive content, and infographics have had a very positive reception within the digital community, as well as short communiques that feature a human interest piece or a little-known fact list. Given that this content is highly trafficked and received, we will continue to leverage novel “new media” strategies to engage our stakeholders, even in light of our limited resources.

Stakeholder Audience

We appreciate that our communications strategy is ambitious; however, the BETO Strategic Communications team leverages our wide partner network to engage these diverse groups. We understand and value the diverse roles and strengths of each organization within our network and work with them to target key audiences that are closely linked with their missions and visions. We too have prioritized stakeholder groups that have the potential to be greatly impacted by BETO's R&D goals (e.g., industry). At the same time, we recognize the inherent role that policymakers and the general public have in removing socioeconomic barriers to the bioeconomy. To this end, BETO Strategic Communications will continue to prioritize industry, policymakers, and the general public moving forward. We also recognize the value that nongovernmental organizations can play in reaching the latter two stakeholder groups—considering our limitations—and hope to develop strong and enduring relationships with these entities in the future.

We agree that more thought and effort must be placed in communicating with our industry partners. The communications needs of this particular stakeholder group must be well-defined, and marketing strategies used to reach diverse segments should be based on thorough analysis. This will require continued coordination between the Strategic Communications team and the technical program areas. Input from industry listening days and workshops will also become a critical component of this effort. Our immediate goal moving forward is to improve access to information that is of critical use to our industry partners and increase awareness of the national laboratory assets that are available to help them overcome critical barriers to commercialization. Continued planning and analysis that yields an in-depth understanding of industry communications needs, as well as well-defined approaches for engagement, will be a critical mid- to long-term priority.

PROGRAMMATIC EVALUATION AND RESPONSE

BIOENERGY TECHNOLOGIES OFFICE PROGRAMMATIC EVALUATION

*Prepared by the Bioenergy Technologies Office
2017 Peer Review Steering Committee*

The Bioenergy Technologies Office (BETO or the Office) has a critical role in fostering the innovation required for an energy future for the United States that will enhance energy independence, drive new economic activity and job creation, and bring environmental and social sustainability for future generations. Technology development and the creation of new forms of industry are inherently risky endeavors. Borne by any one sector or market participant, these risks can be too large to bear, and progress will be slow or non-existent. Risk sharing between public and private interests is necessary to defray exposure and promote investment. Risk sharing is also appropriate, as the benefits of clean energy technologies are not compartmentalized to any one participant.

Economic benefits flow to a broad range of industries, such as agriculture, forestry, transportation and logistics, engineering, construction, and energy. Indirect economic benefits, such as job creation, enhanced gross domestic product, and a greater tax base, flow to the public. Enhanced energy security and environmental improvements are benefits to the nation broadly. In these challenging federal budget conditions, the Peer Review Steering Committee strongly recommends that continued risk and benefit sharing between industry and government be pursued.

The members of the Steering Committee wish to thank the BETO for the opportunity to view the breadth of BETO's research portfolio and provide our feedback and comments. It is highly encouraging that the Office values transparency and actively solicits the input of

external reviews in such a rigorous manner. It is also encouraging that, in looking back at the 2015 Peer Review, so many of the recommendations therein have been acted upon in the last 2 years. The launch of the new consortia is a notable example of responsiveness that should be applauded.

BETO Portfolio: Overall Assessment

The comments that follow are in reference to the BETO portfolio, as presented during the Project Peer Review meeting. However, there are some projects and activities for which BETO is a leader or participant that were not covered by this review. These include the Biomass Research and Development Initiative, Small Business Grants, Defense Production Act, and other efforts. It would be helpful for future review efforts if BETO could outline their entire portfolio for the reviewers and Steering Committee. We understand that, even as it stands, this review was very large, and these other projects are not generally solely associated with BETO, so it could be appropriate that they were not reviewed here. However, they should be summarized to illustrate how they fill potential gaps left in the traditional BETO portfolio we did review. We understand that this puts an additional burden on the review organizers because the size of the review, but leave it as a challenge to the Office to include this information such that the entire effort is understood.

BETO Portfolio: Strengths

Program Management

At the highest level, the program management approach that has been imposed throughout the BETO portfolio is commendable in driving structured, disciplined execution. Stage gates and go/no-go decision points are planned for each process, although there still is some work to do in ensuring that all parties understand and adhere to the process requirements and definitions.

During the Project Peer Review, numerous project principal investigators (PIs) pointed to go/no-go points that were simply treated as tracking milestones. A more widely understood programmatic rigor will ensure an efficient use of BETO resources, allowing reallocation from underperforming projects.

Consortia

The launch of a range of new consortia—the Chemical Catalysis for Bioenergy Consortium (ChemCatBio), Consortium for Computational Physics and Chemistry, Feedstock-Conversion Interface Consortium (FCIC), Agile Biomanufacturing Foundry, Separations Consortium, etc.—is a welcome move to enhance collaboration amongst national laboratories and between the laboratories and industry and to cut across divisions within BETO technical areas. It is appreciated that some consortia are targeting near-term industry challenges, especially in the case of FCIC.

Greater Integration across Technology Areas

The realignment of what were formerly separate technology areas (Thermochemical Conversion, Biochemical Conversion) and the addition of a new conversion focus (Waste to Energy) all under a single name, management structure, and thrust is a welcome move to break down barriers in a broad area where there are no clear technical dividing lines. Hybrid or unorthodox conversion approaches will face less chance of exclusion, and lessons learned will be more easily shared. This is a sound improvement in portfolio management structure.

Staff Continuity

The 2015 Peer Review noted a risk to the Office in terms of staff retention versus turnover. Institutional memory, strong networks, and deep subject matter expertise are all important facets of a strong, technically focused organization. The Steering Committee was pleased to see so many familiar faces in 2017. Senior management of the Office is commended for their efforts to retain and develop key staff members, leading to strong programmatic and knowledge continuity.

BETO Portfolio: Weaknesses

Interaction with Industry

In the introduction of this section, the appropriateness of risk sharing between government and industry was emphasized. If these two partners are to be efficient in moving together towards the mutual goal of building the bioeconomy, close coordination is necessary. Overall, the Office appears to be highly cognizant of the need to interact strongly with industry. Efforts to reach out to industry through requests for information and workshops, to include external advisory boards in the establishment of new consortia, and to incentivize industry project participation through appropriate levels of cost-share requirements are all positive. However, there is an opportunity to improve the level of interaction with industry.

Of note is the perception that annual operating plan (AOP)–funded projects often lack the level of coordination and interaction with industry that is needed to ensure relevant outcomes. PIs need to understand industry issues, and those inputs need to help the decision-making process, not just in the creation of projects, but during their execution. PIs need to work with industry in real time to help optimize project outcomes when choices are made at interim gates or decision points. The addition of industry oversight or formalized advisory positions for AOP projects may be advisable. One particular area that might benefit from this type of coordination is the development of products from lignin. Two or three full-scale facilities are now producing hundreds of tons of lignin daily, and some are burning it for energy. Because this material is not a pure substance and is highly dependent on the up-stream process, utilization of this real-world material in the U.S. Department of Energy’s (DOE’s) development efforts might be well-accepted by the companies now producing it.

BETO should encourage industry to use DOE-funded testbeds and user facilities (e.g., Algae Testbed Public–Private Partnership, National Renewable Energy Laboratory’s Thermochemical Users Facility), both to lever-

age the sunk cost and to ensure that comparisons, to the extent practical, are done using a standard context.

It's not just one way—the Steering Committee appreciates that industry is not always open to involvement, due to concerns with intellectual property protections, lack of bandwidth, or other priorities. Nevertheless, a strong effort by BETO is needed to ramp up the level of interaction and proactively encourage industry to become involved where appropriate. BETO should specifically examine the technical, policy, legal, and other types of barriers to greater industry engagement and, if possible, address those barriers.

Portfolio Focus for Near-Term Success

Some members of the Steering Committee feel that BETO would improve its impact and overall success towards its mission focusing more on research directions that will enable near-term success. Without making tough decisions about diverting resources towards those near-term wins, the whole advanced bioeconomy may be at risk of stalling out at a pre-commercial stage as capital markets grow impatient and seek returns in other, more mature clean-tech sectors. This line of thinking would encourage a more venture capital financing approach to project solicitation and selection, where commercial outcomes are weighted relatively strongly. In an uncertain budgetary environment, it is critically important to demonstrate successes, impacts, and the return on investment for public funding of BETO. Near-term success may be the most important factor in ensuring longer-term support for the Office. In addition to project selection for the near-term portfolio, aggressive project management to ensure accountability and outcomes is important.

Innovation Pipeline

Many of the near-term technologies are inhibited by unanswered research questions that can only be addressed through research at lower technology readiness levels (TRLs). Therefore, even while focusing on near-term “wins,” BETO must ensure that it does not cut itself off from the flow of innovative new technology approaches

and novel research directions. The Steering Committee believes that investment in activities across the TRL spectrum is essential to leveraging innovations in bioenergy, with continued emphasis on commercial viability.

Notwithstanding previous comments around staff continuity, one suggestion is to establish a rotation of external staff or advisors to the Office. Such an effort could be undertaken even while maintaining a steady core, and this would assist in fostering the inflow of novel thinking and experiences.

International Engagement

The Office, as part of the federal government, is rightly focused on spurring domestic innovation for the benefit of the American people. However, the Office takes perhaps too narrow of a focus by limiting projects to be almost entirely domestic in scope (with one or two notable exceptions). Enhanced international collaboration would provide a great ability to access world-leading expertise and innovation and potential funding leverage opportunities. BETO funds need not leave the borders of the United States to spur such collaboration. A good example of this kind of international collaboration is the European Union–Brazil coordinated research call on biofuels (part of the Horizon 2020 Programme), where each “nation” funds research within their own borders, but trans-Atlantic project teams collaborate towards common research goals.

BETO Project Impacts

Project Impact: Support of Advanced Bioenergy Industry

There is significant uncertainty in how impactful the current project portfolio will be in advancing the bioeconomy. Such uncertainty is simply part and parcel of managing research and development (R&D) portfolios.

The Steering Committee in large part defers to the individual technology area Review Panels for the judgment at the project level. However, at the highest portfolio level, what is missing from the Steering Committee's

perspective is the Office's overall assessment of portfolio risk. If the objective is to promote the bioeconomy, then investments and *investment strategies* that do not move the needle towards that objective should be identified as risks. A formal, quantitative approach to assessing, managing, and mitigating risks across the portfolio would be a welcome addition.

That said, risk management at the project level has shown solid improvement in the last 2 years. The stage-gate approach to project management is excellent, and the increased emphasis on validating the technology baseline included at the proposal stage for new projects, right at the outset, will ensure that precious BETO resources are not wasted on attempting to build new technologies on a shaky foundation.

Project Impact: Novel and Innovative Projects

BETO has consistently demonstrated willingness to make changes to its project portfolio to reflect changes in bioenergy trends and technology. After multiple decades of correctly emphasizing cellulosic ethanol as the best way to leverage existing industrial involvement in starch ethanol production and logistics to help industry move to utilize cellulosic feedstocks for renewable fuels, BETO has been able to successfully shift the emphasis to areas that can help this nascent industry continue to grow. A shift to focus on drop-in hydrocarbon fuels is an excellent example of a major strategic change that tracks industry thinking. Additionally, a focus on value-added products will help enhance the return on investment of these first cellulosic conversion plants.

While cellulose to ethanol was an obvious choice for the first fuel to be produced and, therefore, to be supported by BETO, going to next level with other fuels and products is much more challenging for a government organization such as BETO. While everyone can agree that this direction is needed, the specific path is most

likely unknown to BETO. Past studies like the *Top Value-Added Chemicals from Biomass*⁴¹ can be extremely valuable to industry in looking for chemicals of interest that they might be able to derive from biomass. However, most likely it will be the specific commercial developer that will say fuel X or product Y is for the target. Until those types of analyses and input are made by those who will eventually commercialize, BETO could be spending money on the wrong technologies. BETO must be driven by industrial interest. BETO should conduct studies and analyses, even to the point of illustrating scenarios that could have compelling economics to potentially interested firms. Without industrial input guiding deeper development needs, doing fundamental research to show that some of these pathways could be feasible and even economically interesting is as far as BETO should go. Much interaction between possible technology adopters and BETO on what fuel or product to investigate is paramount. BETO's role should be one of making suggestions with the least investment until a pathway of interest is known. The Office is beginning to show signs of extending past that shift to investigate the potential for leveraging properties of non-drop-in fuels that may provide performance or operational benefits. This is a cutting-edge application and an exemplar of novel thinking, but it is not clear that it is what industry will embrace.

However, there is an operational challenge to BETO always being on the forefront of innovation. The program life cycle includes the following phases: (1) request for information, (2) workshop, (3) solicitation, (4) review of proposals, (5) award, (6) technology validation, and (7) execution. With this extensive process, there is no practical way to avoid a lag between the spark of novelty and it lighting a fire in practice. Additionally, once contracts are established there is a necessary lock-in, until certain deliverables or go/no-go points are reached. These factors are unavoidable when managing research

⁴¹ J. E. Holladay, J. F. White, J. J. Bozell, and D. Johnson, *Top Value-Added Chemicals from Biomass, Volume II—Results of Screening for Potential Candidates from Biorefinery Lignin* (Richland, WA: Pacific Northwest National Laboratory, 2007), PNNL-16983, <http://www.pnl.gov/publications/abstracts.asp?report=230923>.

portfolios, and therefore the Office should not be faulted for at times lagging the latest in industry thinking.

However, earlier comments on the Innovation Pipeline and Interaction with Industry provide some guidance for how BETO can best be connected to external sources of fresh thinking.

Project Impact: Alignment with Private-Sector Investments

The level of private-sector support for bioeconomy technologies is primarily driven by the activity of entrepreneurs and the interests of financiers, such as venture capitalists and strategic investors. Entrepreneurs are highly driven by strong vision, but they are often so focused on pushing their particular technology to market that they may miss some key factor or adjacency that will prevent or inhibit their success. Providers of capital are often uninterested in the particulars or details of a technology and only seek to maximize and accelerate the gaining of a profitable return. In neither of those cases do the actors at play have the totality of vision that BETO does, nor do they have the patience for success that a public body such as the Office should.

Therefore, although BETO may provide support to technologies that the private sector is not currently supporting, that could often be explained because the private sector simply has not considered the need for that technology yet or does not have a long enough window for their investments to provide a return. The government, and specifically BETO, is the correct entity to more aggressively invest in lower-maturity technologies with more uncertain chances of success and longer timelines to market. While it makes sense for BETO to support technologies that the private sector is not actively investing in, these new technologies still need to be areas where there is a high confidence that—when brought to a high enough maturity level (TRL) by BETO—there will be an interest by the private sector (through market analyses, engineering analysis, economic analysis, and consultations with potential commercial adopters/inves-

tors). This is a challenging task, and BETO must be diligent to do the homework and keep the portfolio focused on the most prospective options across the technology landscape.

Given this difference between the public and private sectors, the Office's approach to require cost share from industrial partners, with 20% cost share for lower TRL scales, and 50% for Demonstration and Market Transformation (DMT)-type projects makes a lot of sense. A cost share of 50% from a private partner is significant for an unproven technology and really shows that the partner is committed to a successful outcome and isn't just "exploring" the space. As a technology gets closer to market, the risks for the private sector come down, and therefore, a greater share of the investment coming from the industry partners is a suitable approach.

Technology Area Assessments

Feedstock Supply and Logistics

The Feedstock Supply and Logistics component of the BETO portfolio is clearly at a transition point. The Panel appreciates the value of projects such as the Regional Feedstock Logistics and the High Tonnage projects. There is a sense that key feedstock logistics objectives have been explored, technology has been developed, and feasible solutions have been developed. BETO has documented nationally relevant feedstock productivity potential for major bioenergy crops. New, optimized logistics systems have been demonstrated that define the potential for cost reduction and performance improvement in logistics. However, relatively few of these advances have been commercialized at this point because of the lack of conversion facilities and markets. The consensus view is that Feedstock Supply and Logistics efforts should shift to addressing near-term issues, such as feedstock handling, quality measurement, and storage. Further refinement of analysis, forecasting, and prototype systems will have limited value at this point.

One area that could benefit from further technical development is the general depot concept. This has been analyzed, promoted, and incorporated into many BETO projects. However, a commercially relevant scale biorefinery depot system has not been tested. There could be value in evaluating the depot concept at some scale.

Feedstock-Conversion Interface Consortium

The development of the FCIC is an exciting opportunity. There is clear understanding that this interface is the crux of many issues in biorefinery performance. Better integration and system optimization should occur through these projects. In particular, the Panel highlighted the potential of integrated measurement technologies and quality metrics that apply across the supply chain. New innovations in sensing and smart control systems can be pursued. The Panel looks forward to tracking progress of the FCIC over the next review period.

Thermochemical Conversion R&D

The Thermochemical Conversion portfolio, as one of the larger technology areas by both funding and number of products, supports a wide range of projects and varying stages of maturity. The overall portfolio is maturing smoothly, and shifts in focus over the past few review cycles appear to have occurred without disruption. In fact, the program management appears to have taken advantage of lessons learned from previous projects and synergies from co-occurring ones.

The Panel's review of this technology area is exceptionally insightful and has a range of suggestions for refocusing efforts. The Steering Committee reinforces the Panel's comments regarding the challenge of utilizing technologies that convert whole biomass into an intermediate product with an overly broad distribution of chemical constituents and then attempting to hydro-treat that intermediate en masse to hydrocarbons. There is a need to focus on separations to narrow product distributions and identify value-added applications or novel product types based on the unique reactivities and functionalities of biobased molecules.

Earlier, we lauded the combination of thermochemical, biochemical, and waste-to-energy work into a single "Conversion" technology area, a move that should break down silos and enhance cooperation and synergy. There is clearly an opportunity to leverage the body of work accomplished in the Biochemical Conversion Area in relation to separations, either to use as a pretreatment or fractionation of biomass before the application of thermochemical techniques or to assist in separating thermochemically derived intermediates.

Advanced Algal Systems

The Advanced Algal Systems portfolio has made strong progress since the last review, increasing the depth of knowledge in cultivation and yield improvements, while also expanding into areas such as marine strains, enhancing growth using carbon dioxide streams, and increasing the overall commercial viability of algae via high-value co-products.

Advanced Algal Systems is arguably the technical area associated with the greatest amount of commercial risk, particularly given the difficulties moving from bench scale to commercialization. Therefore, future efforts should prioritize the challenges of larger-scale ponds over controlled bench-scale experiments that do not accurately reflect real-world conditions. Projects led by the national laboratories continue to provide high value, producing long-term data and experimental platforms that are leveraged throughout the industry.

Operational costs continue to be one of the largest hurdles for a viable algal industry. While the focus of BETO is energy production, the only realistic pathway to a viable algal-based bioenergy industry is through creating high-value co-products. In addition, co-products that are unique to algae and present a significant market advantage, rather than those that compete with existing markets, should be prioritized. Continued emphasis on improved yield quantity and quality is also necessary to achieve necessary cost reductions. BETO also needs to continue progress to standardize reporting

and methods of calculating key parameters for easier comparison among projects.

With respect to commercial markets, the Panel suggested greater emphasis on industrial collaboration with those who may be integrating fuel intermediates or market co-products to ensure that products meet commercial needs. Similarly, moving toward dynamic market analysis for co-products is necessary to understand the impact on markets as production of co-products scale to ensure a viable path to commercialization.

Biochemical Conversion R&D

BETO put a stake in the ground and challenged the projects to demonstrate (verify) production of hydrocarbon fuels at \$3.00/gasoline gallon equivalent by 2022. The entire research team is utilizing this goal and evaluating individual project techno-economic analyses (TEAs) to meet this goal. The program is using a diversity of project approaches to accomplish this goal and will likely have to down-select to the most promising approaches in the near future. In the past, a goal encompassing cellulosic ethanol was a logical first choice, as ethanol was already in large production from starch and was an accepted fuel in the overall fuel logistics. The choice of the most appropriate hydrocarbon fuel must include input from the market, those that are most likely to actually produce it and make its production successful. BETO must constantly obtain feedback and concerns from probable first adopters through whatever means appropriate.

The most successful projects are the core and consortia projects, which have an impact across BETO and industry at large. Development of new standard procedures makes relevant benchmarking and comparison possible. In the case of Analytical Methods Development and Support, the impact extends industry-wide. Analytical Methods Development and Support has the respect, reputation, and track record of delivering solutions that industry, government, and all concerned have accepted. The need for the type of work that Analytical Methods

Development and Support does has not diminished with past successes, but has only expanded as new areas of research and industrial need are highlighted by an emphasis on new processing routes. Other consortia, to the extent that they have strong voices from industry, have the potential to bring the wide array of expertise across the laboratories to play on the most important problems.

The renewed focus on making chemical products in parallel to fuel is critical and will play a major role in developing a strong biorefining industry. Progress is being made in lignin conversion research, which is addressing BETO's focus on co-products as an economic necessity. And while there are at least two very large-scale operating biorefineries in the United States, neither biorefinery's lignin seemed to be a focus of this research. The choice of adipic acid from lignin seems arbitrary. While it may be an excellent target, there are many structures that meet the selection criteria. It may be counterproductive and premature to pre-identify a specific structure before there is an understanding of the selective transformation of something as complex as lignin. See earlier general comments on how BETO should decide what products to do fundamental research and support work on.

The Review Panel suggested that projects could benefit from more consistent use of TEA, and BETO responded that they are working on a "quick turnaround TEA tool." This was informally suggested to BETO during the 2015 review with little result. It is a very difficult task to develop something that will be both "quick" and "useful." If it is not useful, its development could be a waste of resources. BETO should seek corporate examples (and/or assistance) in how this might be done.

Waste to Energy

The Waste-to-Energy (WTE) Technology Area is a new and welcome addition to BETO's portfolio. Impressively, the area launched as the result of a Small Business Innovation Research solicitation, and it now includes several innovative projects aimed at developing a fea-

sible WTE sector. Biobased WTE is a broadly exciting, popular concept for many reasons—de-coupling the bioenergy sector from land use is a very powerful idea; finding better uses for municipal solid waste (over landfills) is universally favored; and waste feedstocks are already distributed, free, and otherwise pose a problem to businesses and communities. Developing promising technologies to harness energy from biobased community waste streams would have high impact to the national bioeconomy and energy mix, and this is an appropriate focus for BETO and its national laboratory partners.

BETO's work to develop biogas resources is particularly relevant, as there is high interest among multi-sector end users in renewable natural gas. Projects aiming to increase biogas production and utilization should remain an important area of emphasis. Developing scalable biogas reactors and addressing barriers to pipeline injection of biogenic methane would greatly advance the state of WTE technology and help spur private investment considerably.

Beyond DOE's WTE conversion science and pathway development work, feasible approaches for mobilizing distributed wastes (municipal solid waste, food wastes, sludge)—including logistics/handling and development and demonstration of small-scale localized refining technologies—are critically needed. Further improved modeling to provide a deeper understanding of waste feedstock resource availability and infrastructure needs at the regional and local levels would be very impactful.

BETO's project work in the WTE Technology Area thus far is highly complementary and supportive to both private-sector efforts and work by other federal agency partners to realize a robust, domestic WTE industry.

Analysis and Sustainability

Including the Billion-Ton Study series

The fact that sustainability and strategic analysis is an integral part of BETO's programming illustrates an understanding of the pulse of future industry. This

broad work of sustainability analysis will only become increasingly more important as our world searches for everything from better adaptation tools in the face of climate change, to local communities striving to reach their sustainability goals. A project recommendation for this department is to create a standardization tool that could compare these domestic bioenergy fuel types to traditional fossil fuels. While acknowledging the inherent complexity of analysis across these fields, further movement towards standardization may allow the public a better way to assess the pros and cons of different technologies. Just as differing levels of LEED certification in buildings have created a standard that is readily recognized in the construction industry, so too could creating and marketing a sustainability standard in fuels frame up the benefits of bioenergy fuels nicely.

The public is becoming increasingly aware of the “well to wheel” issues with fuels and this could greatly enhance the reputation and use of the products created with biotechnologies. This standardization could also help to integrate the goals of the sustainability and strategic analysis team across the many platforms of biotechnologies advanced within BETO, as this measurement would be consistent and could be referenced throughout the development of each fuel type - be it algal or feedstocks or waste.

While the various models and analyses used to understand the sustainability of a fuel are very complex, a tool that simplifies this information greatly – like the platinum, gold, and silver levels of LEED (Leadership in Energy and Environmental Design) or a report card type style grading system – could allow the public to feel like they can make an informed decision without being a scientist themselves. Another example of this nature of simplification is the manner of presentation the Intergovernmental Panel on Climate Change uses in their reports. They aim to help policymakers grasp both the qualitative and quantitative probability of climate change outcomes in terms of likelihood.

Simplification matters. It could aid in the adoption of these fuels. If, for example, an algal fuel gets an “A” in the air pollution metric and natural gas gets a “C,” this is meaningful to the average person. By increasing the comprehension of the tangible benefits of biotechnology fuel products in the eyes of the public, we increase their marketability.

The measuring of “well-to-wheel” environmental impacts, such as life-cycle land use, water use, and air pollution/emissions, would be critical sustainability metrics from such a tool. They would create a more complete environmental impact picture and enable people to make an “apples-to-apples” comparison with fossil fuels. Of further interest to these stakeholders, and one that may leverage the value of these domestically produced fuels, is the inclusion of metrics such as job creation and national economic benefit.

If BETO were to create and promote such a standardization tool, it could greatly serve both the individual fuel technologies created, as well as the BETO program as a whole. Such a tool could provide a platform to dispel myths, such as the notion that feedstock fuels are utilizing potential food sources. Lastly, it could provide a means to better promote and communicate the great achievements reported in the *2016 Billion-Ton Report*. A standardization tool could create a bridge to not only educate stakeholders on the value of BETO’s work, but help them to feel invested in this important research. In the current political climate, this may be particularly important.

Demonstration and Market Transformation/ Advanced Development and Optimization

In the end-to-end development of bioeconomy technologies, this particular area is perhaps the most challenging from a portfolio management perspective. The investments needed are large; the timelines for projects to be developed and deployed are long; the number of projects that can be funded are low; and, therefore, the risks to the Office are high. However, we would like to

emphasize that the rewards are even higher, for when a DMT project is a success, it is a success not just for the whole technology area, but also for BETO and for the American public too. The successful demonstration of technology at scale is an absolute necessity to allow capital markets to open up for project developers once technology risk is sufficiently reduced. The significance of the Office’s dedicated and patient efforts in assisting the establishment of the POET demonstration cannot be understated.

Given the critical function that DMT performs, the current state of the DMT portfolio seems somewhat disproportionately low. There are few projects, and a low allocation of the overall budget, although the new funding opportunity announcements in this technology area are a welcome addition and should hopefully provide better budgetary balance.

Previous high-investment DMT projects that have not resulted in successful long-term operations at scale are an unfortunate reality that should not be ignored. However, it is clear that lessons have been learned from these experiences. The new emphasis on up-front validation of background technology brought into large projects is an excellent project management practice, and one that should help avoid misallocating time and money on technologies that are not ready for this scale-up stage.

One suggested area that DMT resources could be deployed into is addressing non-capital-intensive market barriers, such as fuel technical or regulatory qualification. These barriers are certainly perceived as risks by investors, but they are areas that are more inexpensively mitigated than technology scaling risks are.

One opportunity to capture value from previous DMT investments is ensuring that Independent Project Analysis Inc.’s involvement in the large cellulosic ethanol projects is fully leveraged. Independent Project Analysis’ initial review of projects was mandated by BETO. Part of Independent Project Analysis’ operating procedure is to “close-out” each capital project that they

review with an analysis of how the project performed. Independent Project Analysis then utilizes that data (without specific reference to the originating company) in their future project evaluations. This is extremely useful, as most large industrial corporations (e.g., Dow, DuPont, others) require that all of their major capital projects have a favorable Independent Project Analysis review prior to authorization of funds. This additional data from these cellulosic projects will not only inform BETO, but also help future capital deployments in cellulosic feedstocks.

Co-Optimization of Fuels and Engines

The Co-Optimizations of Fuels and Engines (Co-Optima) Technology Area and initiative has developed rapidly since the previous Peer Review. The effort is well-organized, clearly focused, and leverages broad expertise across the DOE laboratory complex and both BETO and the Vehicle Technologies Office. To date, the Co-Optima team has conducted an extensive and rigorous potential blendstock screening process, narrowing over 300 candidate blendstocks down to four. This is a major milestone that has substantially contributed to the state of knowledge on co-optimization technology in a relatively short period of time.

The promise of fuel and engine co-optimization is significant; the potential for widespread deployment of drop-in biofuel blends across a large, fuel-efficient, internal-combustion-engine vehicle fleet merits committed DOE investment. This approach innovates beyond the existing model of flex-fuel vehicle and E85 deployment, which has been limited by the E10 blend wall and infrastructure availability. E85's impact on fuel economy is also a deterrent to consumer acceptance as neat ethanol has approximately 30% less energy than gasoline. To the extent that drop-in biofuel blends and efficient, co-optimized engines may alleviate all of these barriers, the Co-Optima initiative offers a novel pathway for transportation sector bioenergy use.

It is well-known that technology development alone will not necessarily spur broad adoption of new fuels and vehicle technologies. This has been seen with other alternative fuel platforms, such as compressed natural gas—which has also developed its own vehicle and fueling systems yet has had a much less robust adoption than hoped, in spite of incentives. Thus, the market transformation activity area is critical to BETO's Co-Optima work to help ensure that typical deployment barriers—such as materials compatibility, infrastructure, and regulatory impediments—are addressed along the development pathway and in close coordination with vehicle original equipment manufacturers, fuel suppliers, fuel retailers, and federal and state regulators (such as the U.S. Environmental Protection Agency and the California Air Resources Board).

BETO should expand the initiative's focus to be more inclusive of medium- and heavy-duty vehicles. A competitively priced, sustainable drop-in biofuel could carve a huge niche in the medium- and heavy-duty fuels market. States like California are strongly embracing renewable diesel, which has shown negligible negative impacts on vehicles or infrastructure. However, its use remains dependent on state credits (where available) to reduce cost barriers. An increased economic benefit through engine optimization and improved fuel economy could counter biofuel cost premiums, particularly in non-incentivized states. Tesla and others are developing heavy-duty electric trucks; however, liquid (diesel) fuel is poised to remain dominant in the trucking industry. There is substantially less potential sway towards electrification among the medium- and heavy-duty vehicle segment than there is in the light-duty vehicle segment, further underscoring its prime relevance to BETO. A sustainable drop-in fuel that proves reliable under various conditions could revolutionize long hauling, as all viable alternatives require costly changes to equipment and/or infrastructure.

Biofuels in Defense and Aviation

Although not a technology area specifically reviewed, BETO's work related to biofuels in defense and aviation warrants comment. The selection of these two key markets for drop-in distillates fuels is a wise choice. Energy security concerns and a lack of carbon-free propulsion technologies for airplanes and certain military vehicles make end users for renewable jet fuel and diesel uniquely motivated and engaged in assisting the development of these fuel technologies. The continued push from commercial aviation concerns to develop a carbon-reduction scheme at the international level via the International Civil Aviation Organization is a further driver for low-carbon fuels. Additionally, the U.S. Department of Defense's and the U.S. Department of Agriculture's (USDA's) cooperation with BETO for the Defense Production Act (DPA) program is a real strength.

The initial round of DPA awardees appear to be making steady, if somewhat slow, progress towards the construction of their facilities. It is absolutely critical that there is success for at least one of these projects in deployment and commercial production. The level of public and industry support and investment in these projects means that much is at stake, and continued access to support from these kinds of sources would be threatened by an inability to deliver on commitments. The Office is encouraged to seek ways to help these projects succeed outside simply providing the committed funding, potentially by making connections between other portfolio projects with relevance to the DPA projects.

The new round of DPA funding is an excellent addition to the portfolio, and the Steering Committee appreciates that a broader set of technologies are eligible for inclusion than in the first round. The timeframes of project development and deployment are long, and it is a wise modification to allow fuel technologies to be proposed that do not yet have ASTM certification but that do have a viable path towards certification.

Outside the DPA program, there is a range of projects across BETO's portfolio that is relevant to the drop-in distillate fuel markets. One general suggestion for setting milestones and goals for these projects is to not overly emphasize that fuel production technologies should make a perfect jet fuel, for example, at the bench or pilot scale. It is far more important to be able to produce a fuel-like product that is affordable than to produce a perfect fit-for-purpose fuel that is unaffordable. Blending, and fuel finishing techniques from traditional refineries, allows some flexibility to still produce an on-spec fuel blend from an initial product that does not necessarily look like a jet fuel mixture.

The Steering Committee commends BETO's role in the development of the *Federal Alternative Jet Fuel Research and Development Strategy* that was published in 2016. This document is a model of interagency cooperation, both in its preparation and in the vision that it shares across a wide range of federal stakeholders. Such a considered and detailed R&D strategy should be a guide to BETO's continued engagement in this technology area.

BETO Portfolio Impacts

Portfolio Impact: Advancing Domestic Resources for a Thriving Bioeconomy

The work of BETO is central to the development of the U.S. bioeconomy. The history of investments, the breadth of technologies supported, the depth to which R&D and analysis are funded by the Office are all major contributors to where the United States is today—as a global leader in the development and deployment of bioenergy and bioproduct technologies. The current portfolio builds on the wealth of knowledge and expertise previously fostered, and it is well-positioned to significantly contribute to commercial success for bioeconomy technologies.

Portfolio Impact: Areas of Improvement

There was discussion at the Review Panel and Steering Committee levels about the challenges of developing economical approaches to produce drop-in hydrocarbon fuels from lignocellulosics. Techno-economically, this outcome has remained challenging, and sustained low petroleum prices only serve to amplify the challenge. Biological feedstocks are rich in highly oxygenated molecules with interesting functionalities and reactivity that could possibly provide a platform for producing energy-carrying fuel molecules that do not simply displace petroleum with a functionally equivalent biobased fuel; instead, these energy-carrying fuel molecules could be a fuel with operational and energetic improvements over the fossil-fuel performance baseline.

This concept is behind the establishment of the fuel and engine co-optimization thrust, which is a commendable and innovative direction for the Office to take. These efforts should be encouraged, and possibly expanded upon, translating these efforts into those transportation markets not yet included in the Co-Optima initiative, such as heavy-duty ground transportation and aviation fuels.

DMT efforts are currently not as strongly supported as in the past. This is a particularly challenging phase of technology development and deployment, and it is particularly challenging to support, as the costs are high and timelines are long. On balance, however, the current allocation of portfolio resources into DMT is somewhat on the low side, even with the newly awarded projects that are commencing this year.

Portfolio Impact: Gaps

In the current political and social climate, the issue of jobs in the energy sector is a hot-button topic. To counter misperceptions that supporting clean energy automatically eliminates jobs, BETO is encouraged to spotlight and strengthen efforts directed at workforce development. Currently, there is a thrust of the Communications

portfolio that targets these ends, and there is also one project in the Advanced Algal Systems Technology Area that is developing post-secondary curricula. There is a need for a more robust effort in promoting workforce development. While there was strong agreement within the Steering Committee that workforce development is a critical need for the bioenergy industry, it is less clear that BETO should take the lead in developing and supporting these programs. The primary competency of BETO is encouraging technological innovation. Therefore, collaboration with other agencies and educational consortia that have the appropriate capacity and experience to build workforce development programming is encouraged.

Portfolio Impact: Supply Chain Focus

The bioenergy supply chain is a closely coupled system, and it is nearly impossible to choose the “chicken or the egg.” BETO’s approach to addressing cost reduction and performance improvement across the whole supply chain is commendable. The new consortia, like the FCIC, recognize that cost and performance must be optimized at the whole scale, not individual components. It is commendable that the Office is tracking and managing portfolio progress from that crosscutting portfolio perspective. That said, the new emphasis on defining “value proposition” and in developing bio-co-products to fully utilize the feedstock stream seems to offer the greatest potential to make a transformative leap for the bioeconomy.

Strategic Plan for a Thriving and Sustainable Bioeconomy

The 2016 *Strategic Plan for a Thriving and Sustainable Bioeconomy* (2016 Strategic Plan) is an outstanding document that provides clarity of purpose and clear guidance for all stages, and timeframes, of planning. Further, it provides an excellent set of success indicators and milestones for the Office to track progress. It appears that this plan is motivating action within

the Office administration, as it informs the *Multi-Year Program Plan* and the AOPs. What is not clear, however, is how well the plan is understood by the broader BETO community. During the Project Peer Review, the Steering Committee perceived that a number of project PIs did not fully understand the greater context in which their work should be understood. Greater internal communication will help project leaders recognize their part in the whole.

The 2016 Strategic Plan's milestones are rightly focused on the actions and future successes of the Office. However, the goals of the Office, and the likelihood of achieving them, in large part rely on external factors, notably the actions of industry participants in the bioeconomy and the development and dynamics of markets for bio-derived products and energy. Therefore, including some predictions or projections about how various components and markets of the bioeconomy will develop over time would be a helpful augmentation to the 2016 Strategic Plan.

The "Billion-Ton" efforts are a real strength. The reports convincingly articulate the vision for how the nation's biomass resources can be mobilized in support of the Office's goals. For many broader stakeholders in the bioeconomy realm, lingering doubts about the materiality of a biobased economy should be put to rest by these analyses, provided they are well-promoted. The clear statement of the significant opportunity ahead is a strong motivator.

2016 Strategic Plan: Gaps

The 2016 Strategic Plan correctly acknowledges the importance of biobased products as key "stepping stones" on the journey towards large-scale, cost-competitive bioenergy. Many offer a more near-term commercialization success opportunity than bioenergy products, and success in one area of the bioeconomy will help maintain interest and investment from those who hold financial and political capital. However, not all bioproducts are going to equally enable BETO's overall

mission. The Office has studied the most important biobased product opportunities, hosting a workshop on the topic in 2015 and publishing a series of excellent, detailed reports that reveal market sizes, pricing dynamics, and details of incumbent technologies. The logical next step, but one that apparently has not been taken yet, is integrating this information to articulate a projection of the development over time of these technologies and the markets they unlock, satisfy, and potentially saturate. This would be very important for helping the Office prioritize investments in the bioproducts area. Absent such a view, BETO risks too broad a set of investments and may sub-optimize outcomes by investing in bioproduct technologies that will not be impactful on the Office's larger bioeconomy development objectives.

Additionally, there is a near-term challenge to strike the right balance between bioproducts and energy. BETO's mission is energy. However, for the reasons outlined above, there is a need to focus on bioproducts due to cost challenges, but they must always be tied to enabling bioenergy production. If BETO has to justify all projects as relating to energy, and yet prolonged low fossil fuel prices make competing with traditional energy products too difficult, then the Office risks being perceived as not attaining its mission. Currently, the drivers for a low-carbon energy future are weak, and until they re-strengthen (which we believe they will), it will be difficult to justify continued investment in what may be a marginally viable bio-industry. Two possible mitigations are to either (1) relax any required link to bioenergy and allow pure bioproduct technology investment that may lead to standalone profitability, or (2) invest in research projects on energy future scenarios to better inform the *Multi-Year Program Plan* and/or Strategic Plans.

The 2016 Strategic Plan lays out a strong case for the benefits of expanding stakeholder engagement and collaboration. In the following sections, the Steering Committee presents their views on the effectiveness of the Office's efforts in acting upon the plan.

Technologies and Market Trends

Recommendations: Responding to Emerging Technologies

BETO has done a thorough job in understanding, and shaping, the range of biomass-related technologies that may contribute to the Office's goals. If there are any potential disruptors to those goals, from a technology perspective, they would most likely come from adjacent sectors, such as energy, transportation, or agriculture.

With what appears to be a relatively stable and significant ongoing shale gas production sector, low natural gas prices and opportunities for stranded natural gas utilization are likely to foster technological innovation in this space. Novel approaches to conversion of natural gas into a range of platform chemicals, or upgrading to liquid fuels, could potentially undercut the markets that BETO's portfolio targets. To mitigate against this risk, intelligence on this technology field will be key. BETO would be well-served to make strong outreach efforts to stakeholders in the natural gas field to gain an enhanced understanding of who is developing what—to best be positioned to understand which product markets may be targeted and, therefore, where BETO may need to shift its investments.

In the transportation sector, one key technology is driving disruptive change. Electrification of light passenger vehicles is well underway and, in combination with demographic and behavioral changes, presents a scenario in which there is potential for dramatic reduction in demand for light-vehicle liquid fuels—in the United States, primarily gasoline. This presents a challenge to major aspects of the Office's Conversion portfolio that target cellulosic feedstocks with pyrolytic or liquefaction technologies. Absent significant and costly hydro-treating, the fuel products of these pathways contain a large proportion of molecules in the gasoline range. Directly mitigating against this risk will be difficult for the Office.

The Steering Committee does not suggest that pyrolytic or liquefaction-type pathways should be deemphasized, as they are some of the most promising for actually reaching the cost/volume targets BETO has set for any liquid fuels. However, recognition that, even against a backdrop of projected continuing low crude prices, the crack spread between gasoline and distillates is likely to continue to increase may be leveraged as an opportunity. A surfeit of low-cost gasoline-range aromatics, whether petro- or bio-derived, could be considered feedstock for combining or reacting with other bio-derived molecules to generate fuel molecules in the diesel or jet range. An additional mitigation against these liquid fuel markets trends is to continue building upon (1) the already established focus on aviation fuels, (2) the recent inclusion of marine fuels focus, and (3) continued emphasis on heavy-vehicle diesel targets. The end users in these markets are all increasingly focused on lowering their carbon footprints, even while their opportunities to electrify are limited.

Recommendations: Responding to Market Trends

Despite short-term ebbs and flows of political will, over time and increasingly global, national, and local regulations are pushing towards imposing a cost on carbon emissions. The development of carbon markets to satisfy these regulatory requirements is a market trend with a significant probability to impact on BETO's goals. Increasing demand for carbon credits will push the effective cost of those credits upwards, and where regulatory schemes account for life-cycle carbon emissions savings of fuels and energy, this trend will assist in closing the techno-economic gap between cost of production and price in the market.

Technologies that capture atmospheric or waste carbon and fix or sequester that carbon into long-lived products or applications, such as biochar (which increases soil carbon in the long term), are going to provide an increasingly valuable opportunity as carbon regulations tighten. The Office should consider the implications of

different scenarios for carbon pricing into their strategic planning process. The Analysis and Sustainability portfolio tools for life-cycle analysis will be valuable.

More widespread adoption and deployment of renewable electricity production appears to have driven power markets to an inflection point. If current trends continue, it appears plausible that low-carbon electricity at very low costs may be a real future for the United States. Very-low-cost electricity could impact the Office's goals in two key ways. Firstly, electrolytic generation of hydrogen may provide a low-carbon source of this key input into the bioeconomy. Secondly, various forms of "electro-fuels" technologies may become increasingly feasible under this scenario. BETO should engage with colleagues in other DOE offices that invest in these technology areas to better understand the latest technology and how it may impact BETO's goals.

Budget Priorities

In the allocation of budgetary resources that is under the Office's control, the relative spending on each technology area of the portfolio is mostly appropriate to the level of need and impact for each area.

Budget Priorities: Future Focus

To the degree possible given congressional mandates, a reduction in the spending on Advanced Algae Systems relative to other areas would be appropriate. Algae technologies are no doubt an important component of the future bioeconomy, but in balance, the impact of BETO investment to date in this space is not in proportion to budgetary allocation. On the other hand, WTE is a highly promising technology area with an appropriate focus on low-cost and environmentally problematic feedstocks, yet it receives a disproportionately small allocation of the budget.

As mentioned earlier, risk sharing at the demonstration stage is an absolutely critical function of the Office, and therefore the Office should consider increasing the allocation to DMT projects.

Given that near-term budgets are likely to be smaller than in the past, it may be wise for BETO to focus on the technology areas that have already been identified and continue to push for results from the existing set of investments rather than spreading focus, and funding, any more thinly.

Collaboration and Partnerships

Technology Area Coordination

Efforts to enhance integration across the technology areas are evident. Breaking down the barrier between Biochemical Conversion and Thermochemical Conversion is a great example—enhancing cross-communication and collaboration between these disciplines will be important to ensure that opportunities for hybrid pathways and leveraging expertise, capabilities, or facilities will be strengthened. The planning and organization of the Office's efforts demonstrates a strong grasp of holistic system thinking, which is so important for maximizing outcomes in an emerging sector of such complexity. The Analysis and Sustainability team is a crucial link across the rest of the portfolio. Their efforts in integrating the findings, developments, and work of the different technology areas provides the overall high-level context in which the PIs or technology managers can see how they impact that bigger picture; their work can also help in decision making by providing a framework for understanding impacts.

Also important for cross-office coordination is the new efforts with Co-Optima, FCIC, ChemCatBio, etc. that bring together experts and capabilities from different technology areas to work on focused new opportunities. These efforts act as a bridge that will strengthen relationships and mutual recognition of capabilities in a way that is highly likely to organically lead to additional collaborations and innovations in areas adjacent to the near-term focus.

Technology Area Knowledge Sharing

On the positive side, the launch of the FCIC is a clear example of lessons learned being fed back into the Office's plans. The challenges uncovered as previous rounds of large DMT projects struggled during commissioning gave a clear signal that concerted effort at the refinery throat was needed. The stakes in such large projects are clearly high, and therefore, acting on those challenges was easily and clearly identified as a priority. However, there may be a gap in identifying and communicating lessons learned at the smaller scales of R&D—bench and pilot projects.

It is a widespread challenge shared across almost all scientific endeavors that failure, missteps, and research dead ends are not communicated—only successes are. This situation naturally leads to different researchers repeating, quietly, the same mistakes that others have made before them. There is no reason to believe that BETO is an exception to this rule, although the strong staff continuity and active engagement of technology managers may partially obviate the issue through a consistency in oversight. BETO could go further, though, by actively drawing out from researchers their challenges and missteps. A card from the deck of Silicon Valley may be appropriate—developing a culture where failure is not a bad thing; in fact, it is something to be, if not celebrated, at least widely discussed to avoid similar dead ends in the future.

DOE Coordination

The launch of the Co-Optima program is an excellent example of the value of coordination across different offices within DOE. There may also be advantages in collaboration between BETO and the Fuel Cell Technologies Office, given their coverage of hydrogen production and distribution efforts for DOE. Hydrogen is, of course, a key input to almost all advanced biofuel technologies, and better understanding of the future opportunities and dynamics in the hydrogen marketplace, both renewable and fossil-derived, will help BETO better understand the biofuel future.

The Steering Committee is not aware of any formal collaboration between BETO and the Advanced Manufacturing Office (AMO). Given the latter's mission, it seems likely that there could be areas in which collaboration would be fruitful, especially as the advanced bioeconomy moves out of the laboratory and into deployment. Advances in catalysis, process control, automation, and combined heat and power are all relevant to scaling up bioenergy technologies. Opportunities for fruitful collaboration will increase as the bioeconomy matures.

More broadly within DOE, continuing and enhancing cooperation with the Advanced Research Projects Agency – Energy (ARPA-E) is important. BETO and ARPA-E are highly complementary and should share a vision for the longer-term development of bioeconomy-relevant technologies. Given the staff continuity and depth of knowledge within BETO and the rotating expertise of program managers in ARPA-E, simply enhancing communication lines between the offices would be mutually beneficial in sparking innovative ideas and transferring deep knowledge.

Interagency Coordination

The remits of other U.S. government agencies, such as USDA, the U.S. Environmental Protection Agency, and the U.S. Department of Transportation, are intrinsically connected to BETO's work. Coordination with these agencies is vitally important to ensure that BETO's goals are successfully achieved. Continued and enhanced dialogue is important; aligned visions for the future and plans for the near term are important to amplify the efforts of each agency towards common goals. A benefit of enhanced dialogue would be encouraging greater levels of “co-ownership” of the bioeconomy, building a stronger coalition of agency stakeholders.

A model for interagency coordination on bioenergy development is the Commercial Aviation Alternative Fuels Initiative, a public-private partnership of aviation stakeholders who are aligned around efforts to commercialize sustainable jet fuels. The Commercial Aviation

Alternative Fuels Initiative is co-sponsored by the Federal Aviation Administration and several aviation trade organizations, with non-dues-paying membership of approximately 450 organizations and 800 stakeholders. Importantly, representatives from a range of relevant U.S. federal agencies participate in coordination calls monthly, sharing information amongst themselves and with and from industry stakeholders.

Clearly, USDA is the agency with the greatest alignment of mission in building a biobased economy for America's future. BETO's vehicles of collaboration with USDA are naturally the strongest of any, in regard to other federal agencies. Coordination of mission is important as there is potential for both redundant action and gaps in the overall plan, where roles and responsibilities are not clear. The Biomass Research and Development Board is an appropriate venue to coordinate between these two agencies and with the other agency participants, but there are some areas of overlap outside the remit of that board (crop statistics, tracking of rural

economies, etc.). Continued close coordination between USDA and DOE is a clear need.

Stakeholder Coordination

BETO workshops are an excellent "on-ramp" for new ideas, industry input, and stakeholder engagement. They form an important foundation for seeking early feedback on concepts for new programs or funding opportunity announcements, and they should certainly be continued as a best practice within the Office.

The consortia have less of a track record on which to judge their effectiveness, but they have been established with a mission to coordinate and collaborate on focused research areas. In order to ensure that mission is met, the consortia management will need to be diligent to remain open to interaction outside each consortium's core working team, proactively engage industry partners and advisory board representatives, and promote the work of the consortia outside of BETO.

BETO PROGRAMMATIC RESPONSE

Prepared by BETO leadership

Introduction

BETO leadership would like to thank the Steering Committee for its work, technical support, and critical insights throughout the implementation of the 2017 Project Peer Review and Program Management Review. The Office appreciates all of the feedback provided and is encouraged by the Committee's support for many of BETO's current research activities and plans for future directions.

This section represents BETO's response to the Steering Committee's final report. BETO will work with the program and technology managers to implement a number of the recommendations and address many of

the Committee's concerns in the coming years. BETO will consider these in developing and implementing a coordinated framework for managing its portfolio based on systematically investigating, evaluating, and selecting the most promising opportunities across a wide range of emerging technologies and TRLs. This approach will support a diverse portfolio in applied R&D, enabling industry to identify promising targets for scale-up and demonstration with increasing integration and complexity.

Going forward, the Office will emphasize early-stage applied R&D to strengthen the body of knowledge enabling industry to demonstrate and deploy sustainable bioenergy technologies capable of producing price-competitive biofuels from non-food sources of biomass, such as wastes, agricultural residues, and energy crops (e.g., switchgrass and algae). Research focus areas will include the following: detailed understanding and opti-

mization of the physics and chemistry of each preprocessing step of highly variable biomass; identification and molecular characterization of high-performing algal strains; and development of engineered organisms and novel catalysts.

As described in the Office's 2016 Strategic Plan, BETO's primary focus will be on R&D to produce "drop-in" biofuels that are compatible with existing fueling infrastructure and vehicles across a range of transportation modes, including renewable gasoline, diesel, and jet fuels. The Office will also support early-stage R&D on converting biomass into high-value, renewable chemicals and products that can enhance the economics of biofuel production and improve energy security by displacing demand for oil imports and supplementing U.S. exports. Also, in collaboration with the Vehicle Technologies Office, BETO will continue the Co-Optima initiative to enable the development of biobased fuels and additives that have the potential to realize up to 15% fuel economy gain when blended with petroleum and used in high-efficiency engines.

Steering Committee Recommendations Overview

The Steering Committee provided specific recommendations, such as launching consortia to enhance collaboration between the national laboratories and industry, enhancing cross-discipline collaboration and communication, and retaining and developing staff. We agree with these suggestions and appreciate that others are noticing the strength of the BETO team. The Agile Biomanufacturing Foundry and ChemCatBio Consortia have gotten off to a good start and will continue to focus on overcoming conversion efficiency barriers. The FCIC represents BETO's newest cross-discipline collaboration that will focus on increased, robust conversion yields.

BETO Portfolio Recommendations

The Steering Committee has made several recommendations for the BETO project portfolio, including

improving industry engagement, diversifying the project portfolio, focusing on medium- and heavy-duty vehicles and aviation jet fuel, and capitalizing on oxygenated molecules in biomass.

Industry Engagement

BETO has a long history of public-private partnerships that have enabled collaboration with industry. However, with compressed budgets, the BETO team agrees with the Steering Committee that industrial engagement is more important than ever. To this end, BETO is employing additional mechanisms to work towards improving and expanding collaboration with industry, including leveraging cooperative R&D agreements, such as the creative cooperative R&D agreements administered through our consortia. For example, BETO is working through the Energy Materials Network to develop targeted consortia led by the national laboratories that integrate all phases of R&D, from discovery through optimization, and facilitate industry access to multiple national laboratories' capabilities. The overall goal is to accelerate material development cycles and to enable U.S. manufacturers to deliver innovative, made-in-America products to the world market. Another example of BETO's industry engagement efforts is the ChemCatBio Consortium, which continually engages with industry to advance common needs.

The consortia employ a laboratory call process that enables working with industry as well. This provides access to the entire distribution of world-class experts and to the national laboratory capabilities. By working together and serving as a singular point, focused on targeted topics, more efficient solutions to applied R&D problems can be employed. Additionally, advisory boards provide input on what efforts might best be tackled by industry, academia, or the laboratories; this supports more efficient use of funds and will continue.

As part of BETO's industry engagement strategy, the Peer Review Steering Committee specifically pointed out the usefulness of industrial input in working with lignin because there are now a few companies out there

producing and using lignin for combustion and other products. We agree that with these commercial sources of lignin, these companies are gaining scale-up experience and will likely want to pursue higher-value products for this complex molecule. Our work in this area is seeing breakthroughs in utilizing lignin for higher-value products, and this represents a key strategy to derive greater value from biomass.

Portfolio Diversity

In terms of portfolio diversity, one of the recommendations is to engage in early TRL work, and investment in activities across the TRL spectrum is essential to leveraging innovations in bioenergy. BETO supports innovative solutions and appreciates the recommendation to continue to engage stakeholders to capture the latest thinkers in rapidly evolving research areas. BETO agrees that it is crucial to keep a steady flow of new ideas coming into the technology pipeline and to underscore the most promising ideas with strong, early R&D.

Another recommendation was to seek near-term wins. While one can define a project's success by whether it reaches its ultimate goal—for example, an IBR reaching its design production capacity of 20 million gallons per year—BETO thinks there are opportunities to look at successes along the way. The Steering Committee's point is well-taken, and accordingly, BETO needs to adjust what is considered a success at different stages along the research development pipeline. BETO approaches this by collecting success stories throughout a project's lifetime to share the latest breakthroughs throughout the bioenergy sector and assist with justification for continued funding. The Steering Committee's recommendation that BETO consider utilizing a venture capital approach to funding is interesting and will be considered. Focusing constrained funding on a near-term, highly visible wins could improve overall public opinion of the value and impact of a growing bioeconomy. Such near-term opportunities with strong stakeholder support include renewable jet fuel for aviation and WTE approaches, both of which are in the current portfolio.

Medium-Duty, Heavy-Duty, and Aviation Jet Fuel

The Peer Review Steering Committee suggests that BETO focus on medium- and heavy-duty vehicle fuel, as well as aviation jet fuel. BETO recognizes that distillates are a significant opportunity. BETO has incorporated sessions on marine fuels in its July 2017 conference—Bioeconomy 2017: Domestic Resources for a Vibrant Future—to keep the discussion relevant. The Office has also been actively engaging with renewable aviation fuels, with many projects focused on this nearer-term opportunity.

Oxygenated Molecules in Biomass

The Steering Committee also recommended that BETO capitalize on oxygenated molecules found in biomass. There was some discussion on the appropriate timing to move towards products to leverage the strengths of biomass. BETO agrees that biological feedstocks are rich in highly oxygenated molecules with functionalities and reactivity that could provide a platform for producing energy-carrying fuel molecules that do not simply displace petroleum with a functionally equivalent biobased fuel—but could instead be a fuel with operational and energetic improvements over the fossil-fuel performance baseline.

BETO believes that our Co-Optima efforts are expanding the group of molecules derived from biomass that can enhance the performance of fuels. BETO will continue to support collaborative R&D with BETO's Vehicles Technologies Office within Co-Optima to develop biobased fuels and additives with the potential to enable an up to 15% fuel economy gain when blended with petroleum and used in high-efficiency engines. BETO is beginning to gather stakeholder input to answer the question, "How do we capture the rich functionality in oxygenated species that are present in the polymers we start with?"

Advancing the Bioeconomy

With respect to BETO's work to advance the bioeconomy, the Steering Committee recommended collaborations with others to build a bioenergy workforce. BETO

is taking a leadership role in the Biomass Research and Development Board's Bioeconomy Initiative, which brings together multiple agencies with roles in advancing the bioeconomy. Workforce development is a recurring theme within the industry development, and joint efforts with USDA, the National Science Foundation, and others to find creative solutions to developing a workforce is a key component of the Bioeconomy Initiative.

The Steering Committee felt that DMT efforts are currently not as strongly supported as in the past and recommended more funding. This will likely be a challenge with the anticipated budget constraints going forward. As previously mentioned in this report, the DMT Program has recently been renamed the Advanced Development and Optimization (ADO) Program. BETO continues to look at the opportunity to inform the new administration, Congress, and Office of Management and Budget about the value of investing to advance to pilot-, engineering-, demonstration-, and pioneer-scale projects.

Prior to scale-up and integration, there is enormous technology uncertainty, and it is a vital role of government to reduce this technology uncertainty through strong R&D. BETO promotes pilot and engineering scales as the first significant integration of a biomass processing system. As such, a key driving force for the bioenergy R&D pipeline is uncovering the barriers that need to be studied and become visible at larger scale. Bioenergy production requires significant integration of unit operations, such as feedstock handling. Pilot-scale processes are typically facilities or projects that do not operate for gain and operate at a loss. These systems are highly specialized, capital expenditure-intensive, and operate solely in a campaign mode. Due to the cost and technology uncertainty, small- and medium-sized companies will not be able to invest in critical pilot-scale testing, and strong technologies are being shelved due to lack of funds and a lack of appetite for both risk and technology uncertainty. Consequently, there is a lot of innovation that will be lost if government agencies are not encouraged to continue collaborating with businesses on pilot-scale projects.

Strategic Plan for a Thriving Sustainable Bioeconomy

The 2016 Strategic Plan, which BETO published in December of 2016, provides the framework to realize DOE-BETO's mission to research and develop transformative, revolutionary, sustainable bioenergy technologies for a prosperous nation. The Steering Committee made two primary recommendations with respect to BETO's strategy: (1) prioritization of bioproduct investments in the near and long term, and (2) improved communication of the 2016 Strategic Plan.

There are sensitivities around prioritizing bioproducts investment in the near and long term. Questions related to which co-products are a priority, the size of the market, and scalability with fuels need to be considered. Often the earliest-stage TRLs supporting biomass conversion can allow for a bioproducts or fuels approach, but as you get to development, the paths diverge somewhat.

BETO is working to increase use of available TEA tools and to apply them to bioproducts development. The scalability of singular products into multiple markets, and multiple derivative products derived from a platform intermediate into adjacent markets, are important strategies to explore as co-products scale up with biofuels, and there are some necessary down-selections that will be enforced with or without budgetary constraints. Regardless, multiple markets are beneficial to diversify market risk and to promote investments. BETO agrees with the Steering Committee that the products must integrate with fuel and energy future scenarios.

The Steering Committee also recommended better communication of the recent BETO 2016 Strategic Plan. Additionally, the Steering Committee suggested that BETO increase promotion of *The Billion Ton Bioeconomy Initiative: Challenges and Opportunities*⁴² report, which was published in November 2016. These documents are sources of both internal objectives and interagency communication. BETO is working to educate DOE leadership and administration of the value of the bioeconomy, and these documents serve as important tools

for this education. BETO will look for ways to amplify the dissemination of these documents to the external stakeholder community.

Technology and Market Trends

BETO recognizes that the energy sector requires adaptability to technological innovation, changing market dynamics, and policy impacts. The development of the bioeconomy depends upon generating both market pull and market push to effectively establish a functioning supply chain. The Peer Review Steering Committee identified two opportunities for improvement in technology and market trends, including the incorporation of carbon pricing scenarios within strategic planning exercises and collaboration with other DOE offices on R&D for using surplus renewable electricity.

BETO agrees with the recommendation to consider different carbon pricing scenarios. When coupled with a sensitivity analysis, BETO life-cycle assessments and TEAs could provide the opportunity to examine different carbon pricing scenarios. BETO does not conduct policy analysis but can look at different scenarios and assess the sensitivities of different policy options in terms of economic and environmental impacts.

Collaboration with other DOE offices on R&D for using surplus renewable electricity was discussed at the Office-sponsored Bioeconomy 2017 conference. The Office has conducted R&D related to leveraging renewable electricity. In addition, BETO agrees that enhancing the level of interaction and cooperation with ARPA-E is important. BETO has previously shared information, including TEAs of electro-fuels, with ARPA-E, which had funding under its electro-fuels program. This recommendation also relates to the Algae Cultivation for Carbon Capture and Utilization Workshop that BETO hosted in May 2017, as well as the Engineered Carbon Reduction Listening Day hosted in July 2017. These events gathered stakeholder input through facilitated

discussions focused on innovative technologies and business strategies for growing algae on waste carbon dioxide resources and for creating tools that leverage renewable power to manage carbon and create advanced bioproduct pathways for new economic opportunities.

Budget Priorities

In terms of budget priorities, the Steering Committee highlighted the significant funding levels allocated to the Advanced Algal Systems Program and the low levels of funding allocated to the WTE and DMT (now ADO) Programs. The Committee recommended placing an emphasis on getting results from existing investments, rather than spreading funding too thinly.

With respect to the funding for Advanced Algal Systems, this research has significant support from Congress. BETO agrees that WTE is a very promising area. Congress also has demonstrated support for this research. There are a lot of other agencies that are doing WTE, all with distinct roles. BETO has conducted several workshops on this topic and is working to identify the unique aspects for BETO in WTE that align with BETO's distinct expertise. The Office has also been very strategic in using the Small Business Innovative Research program to explore WTE and has awarded several small business projects through Phase I and Phase II efforts in this area. BETO is leveraging strategic use of these projects to seed distinct, innovative R&D as BETO grows its WTE Program.

BETO agrees with the Steering Committee that DMT, now ADO, is a critical function not just to the Office, but to the bioenergy sector, as pilot- and engineering-scale work drives research in new directions. BETO also agrees with the recommendation to place emphasis on getting results from existing investments rather than spreading funding too thinly. The recent fiscal year 2018 budget request scenario development gave BETO the opportunity to look at this area with a fresh perspective and prioritize

⁴² Biomass Research and Development Board (BRDI), *The Billion Ton Bioeconomy Initiative: Challenges and Opportunities* (BRDI, November 2016), https://biomassboard.gov/pdfs/the_bioeconomy_initiative.pdf.

or rethink the portfolio. There is no room for spreading the funding too thinly under budgetary constraints.

There needs to be a portfolio balance between existing and emerging projects. The question BETO is trying to answer is, “How does the Office attain a balance of continually achieving near- and mid-term results, on one hand, while looking at earlier research on the other hand?” BETO thinks this can be an opportunity for education as BETO has a great pipeline already that can be leveraged for some time. BETO is building on prior investments and utilizing the results as we go forward. For example, BETO has analyzed the projects funded over the last 10 years and tried to capture the results and assess the benefits realized, lessons learned, and ripple effects of investments made; this extends into areas beyond the immediate research, development, and demonstration goal of specific biofuel technologies projects.

Collaborations and Partnerships

In the area of collaborations and partnerships, the Steering Committee recommended that BETO increase its coordination with DOE Office of Energy Efficiency and Renewable Energy offices, including the Fuel Cell Technologies Office, AMO, and ARPA-E. Additionally, the Committee recommended expanding federal agency coordination within the Biomass R&D Board.

There are potential opportunities to learn about renewable hydrogen production and distribution efforts from the Fuel Cell Technologies Office. BETO has been using the Fuel Cell Technologies Office as a knowledge resource and is pleased to see that their big initiative on moving towards renewable hydrogen is cost-competitive with steam methane reforming. BETO is also beginning to see promising scenarios with the distributed production of hydrogen, which will be highly beneficial to distributed bioenergy production technology.

There is also potential for increased collaboration with AMO on deploying advanced technologies within the emerging bioeconomy, particularly catalysis, process control automation, and process intensification technologies.

BETO currently interacts with AMO on process intensification, separations, and products. Members of BETO are involved in advisory boards for the Rapid Advancement in Process Intensification Deployment Manufacturing Institute. On separations, there is a large effort at AMO that BETO is following, and the Office is leveraging AMO’s R&D progress while focusing on the separation challenges that are very specific to bioenergy challenges. BETO thinks process intensification is absolutely vital, and distributed bioenergy technologies will only have cost-effective modular systems with breakthroughs in process identification. While BETO believes our connectivity with AMO has improved recently, there is further room to improve.

The Committee recommends capitalizing on complementary efforts of ARPA-E and on their projects, such as leveraging electro-fuels. There is a very good relationship already and BETO currently participates in a joint quarterly with ARPA-E and Office of Science leadership. BETO is beginning to see a transition in ARPA-E’s innovative research projects successfully competing and being awarded funding in BETO’s more applied portfolio.

The Steering Committee felt the scope of the Biomass R&D Board should be expanded for additional coordination between the two agencies (DOE and USDA). In the past 2 years, the two agencies have exchanged staff on detail assignments and have held summits with DOE and USDA laboratories. BETO values knowing about USDA capabilities and is working to ensuring that laboratory efforts can be more synergistic and avoid any duplication of effort. The Biomass R&D Board is currently composed of members from DOE, USDA, the U.S. Department of the Interior, the U.S. Department of Transportation, the U.S. Department of Defense, the U.S. Environmental Protection Agency, the National Science Foundation, and the Office of Science and Technology Policy. Previously, other agencies that are not part of the eight have been invited, as needed, to come into the Biomass R&D Board on different topics. That is something BETO can look at again and use as appropriate in the future to expand the number of agencies actively coordinating across the bioeconomy.

U.S. DEPARTMENT OF
ENERGY

Office of
**ENERGY EFFICIENCY &
RENEWABLE ENERGY**

For more information, visit: energy.gov/eere

DOE/EE-1014 • December 2017