



Battelle

Vince Contini

Fritz Eubanks

Mike Heinrichs

Manoj Valluri

Mike Jansen

Paul George

Mahan Mansouri

# Manufacturing Cost Analyses of Fuel Cell Systems for Primary Power and Combined Heat and Power Applications

3/31/2017

# Outline

- Approach
- Design Basis
- Representative Systems
- PEM System Costs
  - BOP
  - Stack
  - Total
- SOFC System Costs
  - BOP
  - Stack
  - Total
  - Sensitivity Analysis
- Summary/Conclusions

# Approach – Manufacturing Cost Analysis Methodology

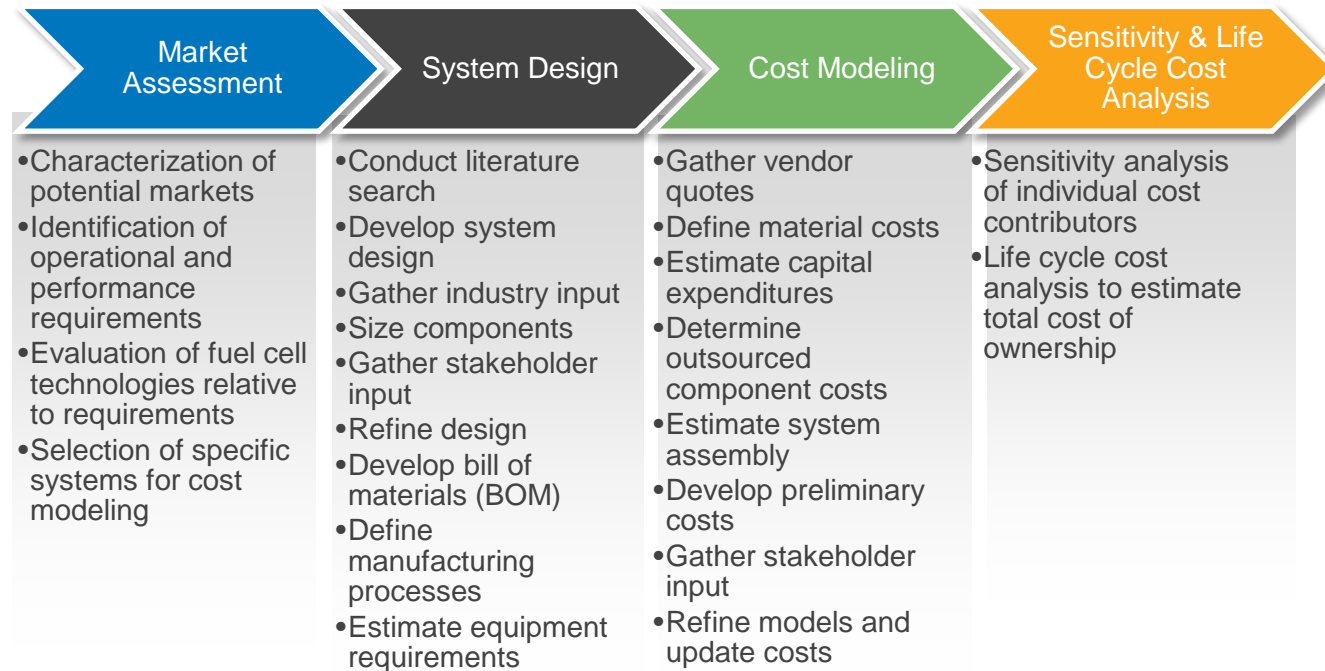

# Primary Power/CHP Nominal Design Basis

Metric/Feature	Objective
Input, Fuel	Utility Natural Gas or Propane (>30 psig preferred)
Input, Air	Ambient air (-20° to 50°C)
Input, Other	N/A
Output	120/240 VAC 480 VAC 3-phase optional
Net Power Output	1, 5, 10, 25, 100, 250 kW
System Efficiency (electrical)	
LTPEM	30%
SOFC	40%
System Efficiency Overall	
LTPEM	80%
SOFC	90%
System Life	50,000 hours
System Maintenance Interval (filter change: sulfur trap, air filter, fuel filter)	1 year
Grid Connection	Yes, local and/or utility
Operate off-grid	Yes, critical load back-up
Start off-grid	No

Material presented here will concentrate on 25 and 250 kW systems

# Representative LTPEM CHP system

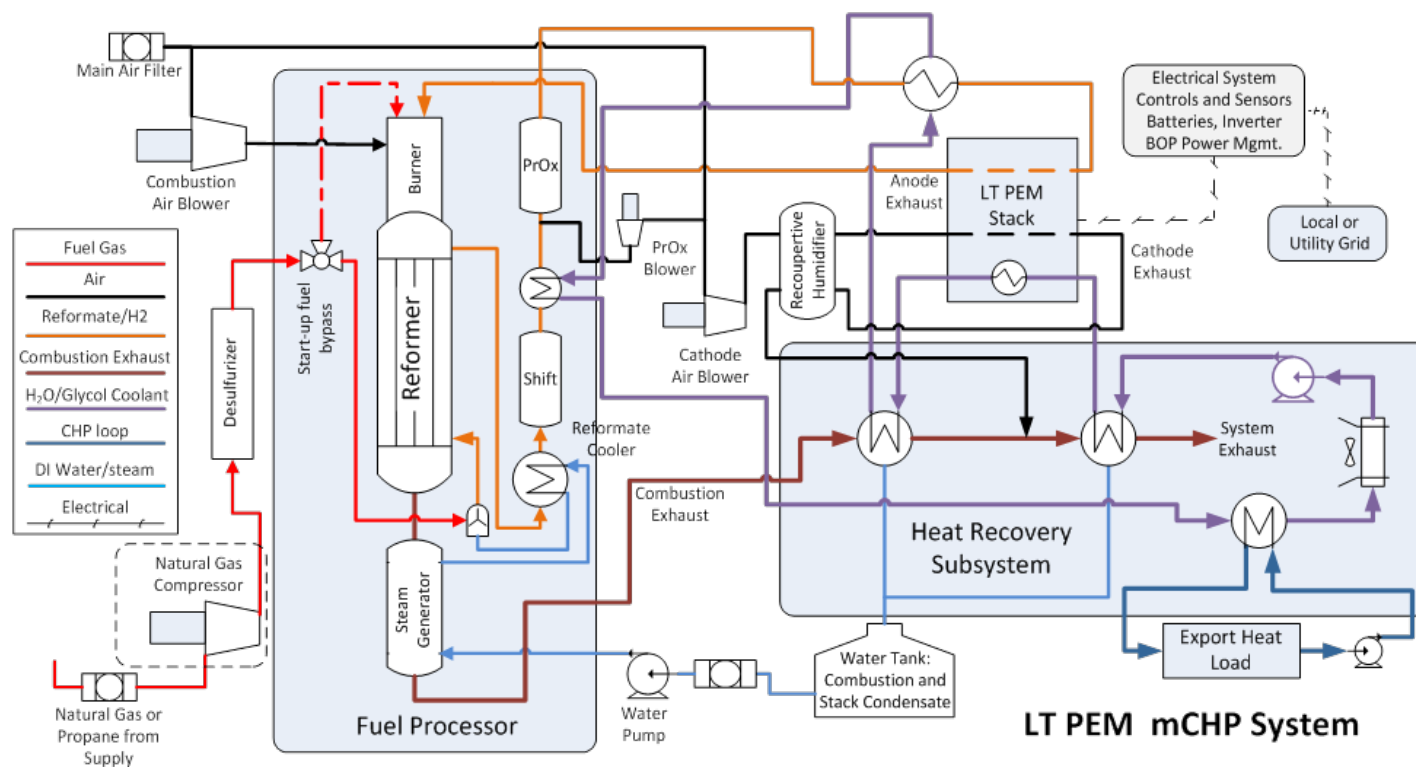

**Complex system due to need for fuel processing with H<sub>2</sub> cleanup – requiring multiple heat exchangers**

# Representative SOFC CHP system

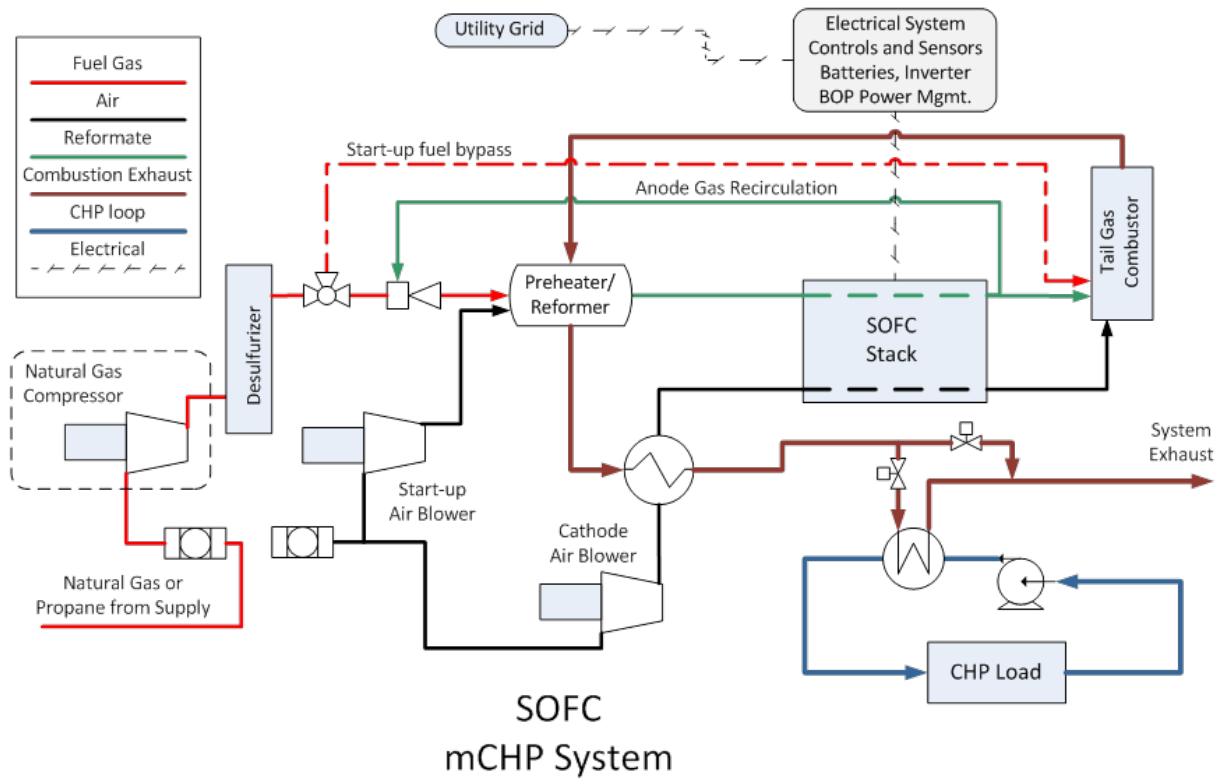

**SOFC system is less complex than the PEM system due to simpler fuel processor and less needed heat exchangers**

## 25-kW CHP PEM BOP Cost

BoP Components	25 kW			
	100 Units (\$/each)	1000 Units (\$/each)	10,000 Units (\$/each)	50,000 Units (\$/each)
Fuel Supply	\$1,782	\$646	\$553	\$508
Water Supply	\$2,267	\$2,083	\$1,495	\$1,164
Fuel Processing	\$19,140	\$14,355	\$11,813	\$10,537
Air Supply (Combustion)	\$1,311	\$1,198	\$1,106	\$1,069
Air Supply (Cathode)	\$1,550	\$1,270	\$1,098	\$1,045
Heat Recovery	\$4,198	\$3,109	\$2,715	\$2,545
AC Power	\$11,150	\$10,321	\$9,555	\$8,899
DC Power	\$10,638	\$7,900	\$7,283	\$6,970
Instrumentation and Control	\$3,068	\$2,762	\$2,495	\$2,357
Assembly Components	\$2,019	\$1,836	\$1,652	\$1,485
Additional Work Estimate	\$4,300	\$3,400	\$2,900	\$2,700
<b>BOP Total</b>	<b>\$61,423</b>	<b>\$48,879</b>	<b>\$42,665</b>	<b>\$39,279</b>

**BOP has several significant contributors, particularly for the PEM systems – most notably, the fuel processing and AC & DC Power**

# 25-kW CHP PEM BOP Cost Distribution

- Fuel Supply
- Water Supply
- Fuel Processing
- Air Supply (combustion)
- Air Supply (cathode)
- Heat Recovery
- AC Power
- DC Power
- Instrumentation and Controls
- Assembly Components
- Additional Work Estimate

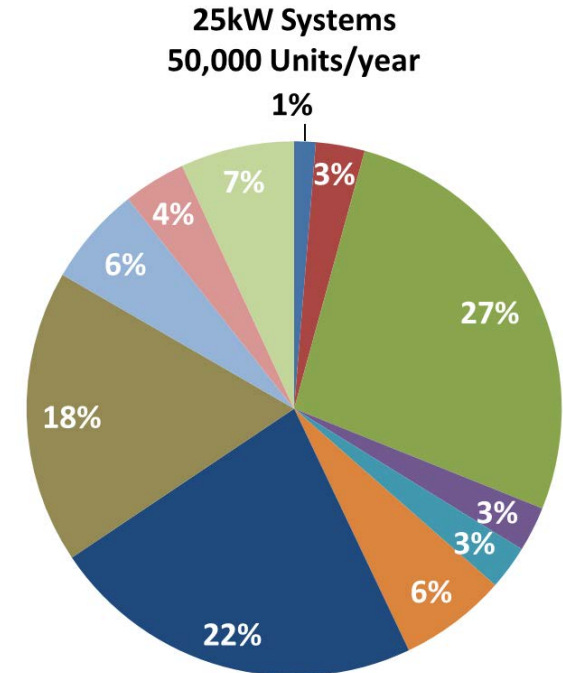
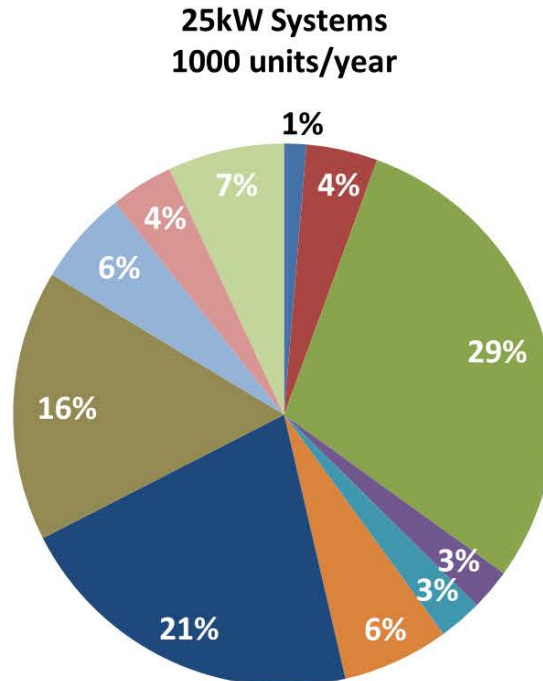

**BOP has several significant contributors, particularly for the PEM systems – most notably, the fuel processing and AC & DC Power – a hybrid 3-port DC/AC inverter has potential to lower cost of power equipment**



# 250-kW CHP PEM BOP Cost

BOP Components	250 kW			
	100 Units (\$/each)	1,000 Units (\$/each)	10,000 Units (\$/each)	50,000 Units (\$/each)
Fuel Supply	\$14,879	\$12,452	\$11,166	\$10,358
Water Supply	\$3,340	\$3,144	\$3,023	\$2,915
Fuel Processing	\$94,462	\$79,221	\$70,458	\$66,491
Air Supply	\$17,254	\$15,851	\$14,473	\$13,607
Heat Recovery	\$56,215	\$51,218	\$46,680	\$44,665
Power Electronics	\$114,436	\$91,898	\$72,617	\$59,454
Instrumentation and Control	\$2,622	\$2,340	\$2,108	\$2,055
Assembly Components	\$22,540	\$20,490	\$18,440	\$16,600
Additional Work Estimate	\$24,300	\$22,100	\$19,900	\$17,900
<b>BOP Total</b>	<b>\$350,048</b>	<b>\$298,714</b>	<b>\$258,865</b>	<b>\$234,045</b>

**BOP has several significant contributors– most notably, AC & DC Power – fuel processing is less significant than for PEM systems**

# 250-kW CHP PEM BOP Cost Distribution

- Fuel supply
- Water Supply
- Fuel Processor
- Air Supply
- Heat Recovery
- Power Electronics
- Control and Instrumentation
- Assembly Comp
- + Work Estimate

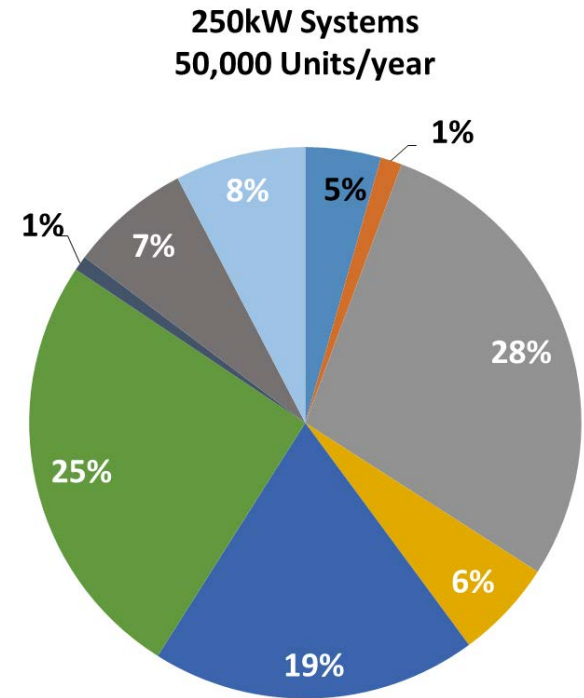
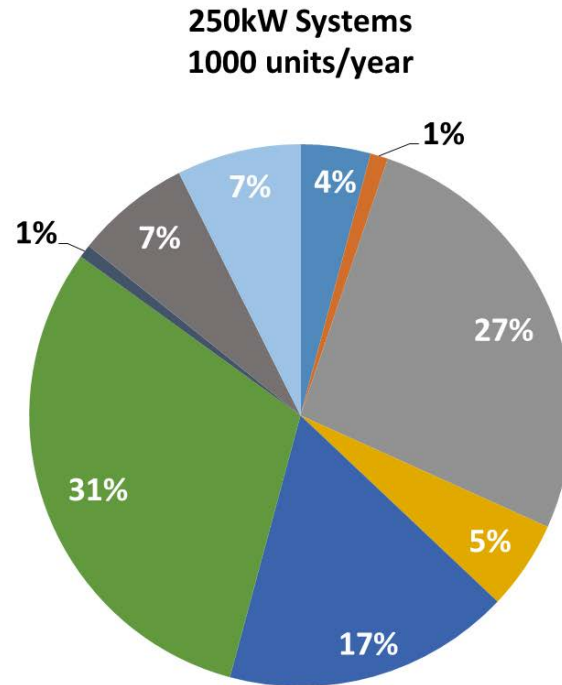

**BOP has several significant contributors, particularly for the PEM systems – most notably, the fuel processing and AC & DC Power – a hybrid 3-port DC/AC inverter has potential to lower cost of power equipment**

# 25-kW CHP PEM Stack Manufacturing Cost

Stack Components	25 kW System			
	100 Units	1,000 Units	10,000 Units	50,000 Units
MEA	\$10,288	\$5,266	\$3,624	\$3,515
Anode / Cooling Gasket	\$508	\$304	\$240	\$238
Cathode Gasket	\$179	\$81	\$65	\$65
Anode Bipolar Plate	\$1,986	\$1,229	\$1,065	\$1,064
Cathode Bipolar Plate	\$1,905	\$1,148	\$983	\$983
End plates	\$111	\$58	\$53	\$35
Assembly hardware	\$94	\$88	\$82	\$78
Assembly labor	\$158	\$126	\$123	\$123
Test and conditioning	\$1,445	\$227	\$120	\$116
<b>Total</b>	<b>\$16,674</b>	<b>\$8,527</b>	<b>\$6,354</b>	<b>\$6,217</b>
<b>Cost per kW<sub>net</sub></b>	<b>\$667</b>	<b>\$341</b>	<b>\$254</b>	<b>\$249</b>

The catalyst, membrane and gas diffusion layer (GDL) all contribute to make the membrane electrode assembly (MEA) the largest contributor to stack cost

# 25-kW CHP PEM Fuel Cell Stack Volume Trend

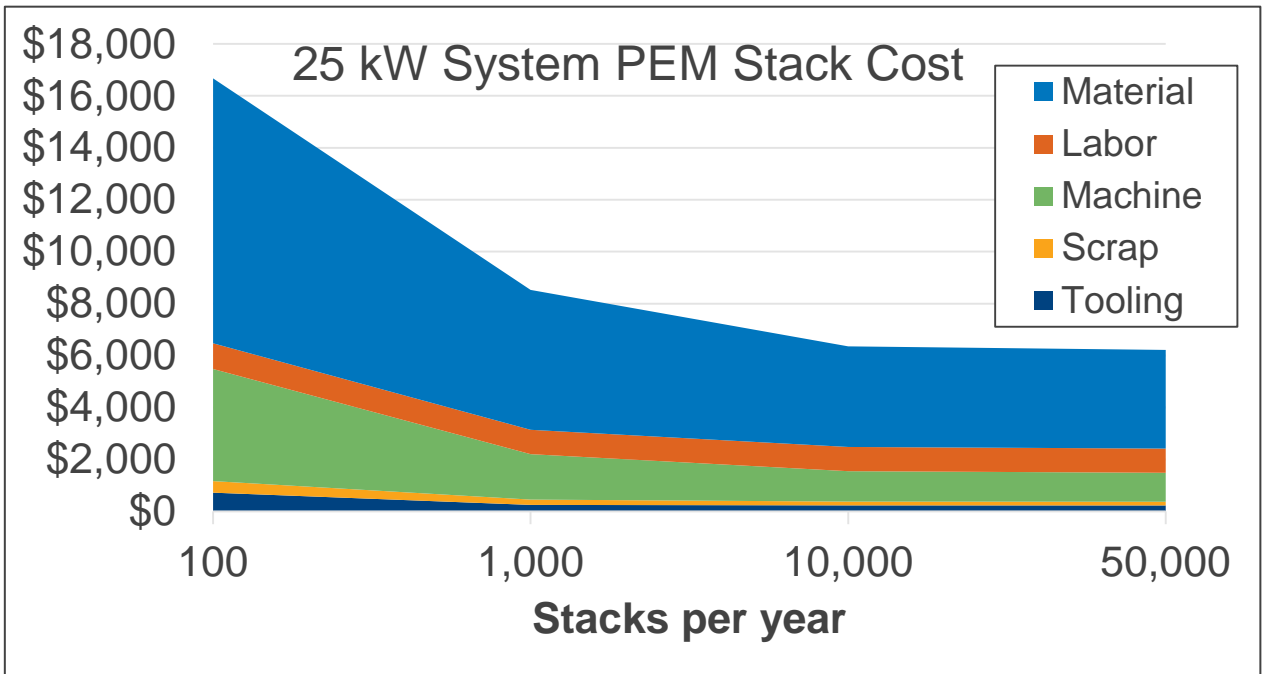

**Material cost is the highest contributor at all production levels**

## 25-kW CHP PEM Fuel Cell System Cost Summary

Description	100 Units	1,000 Units	10,000 Units	50,000 Units
Total stack manufacturing cost, with scrap	\$16,674	\$8,527	\$6,354	\$6,217
Stack manufacturing capital cost	\$567	\$101	\$65	\$64
CHP Hardware	\$22,817	\$18,890	\$17,356	\$16,329
FC BOP Hardware	\$38,606	\$29,990	\$25,309	\$22,950
System assembly, test, and conditioning	\$1,558	\$365	\$293	\$293
Total system cost, <b>pre-markup</b>	\$80,221	\$57,873	\$49,378	\$45,852
System cost per net KW, <b>pre-markup</b>	\$3,209	\$2,315	\$1,975	\$1,834
Sales markup	50%	50%	50%	50%
Total system cost, with markup	\$120,332	\$86,809	\$74,067	\$68,779
System cost per net KW, with markup	\$4,813	\$3,472	\$2,963	\$2,751

**BOP dominates system cost for all capacities and volumes examined**

# 25-kW PEM System Cost - Volume Trend

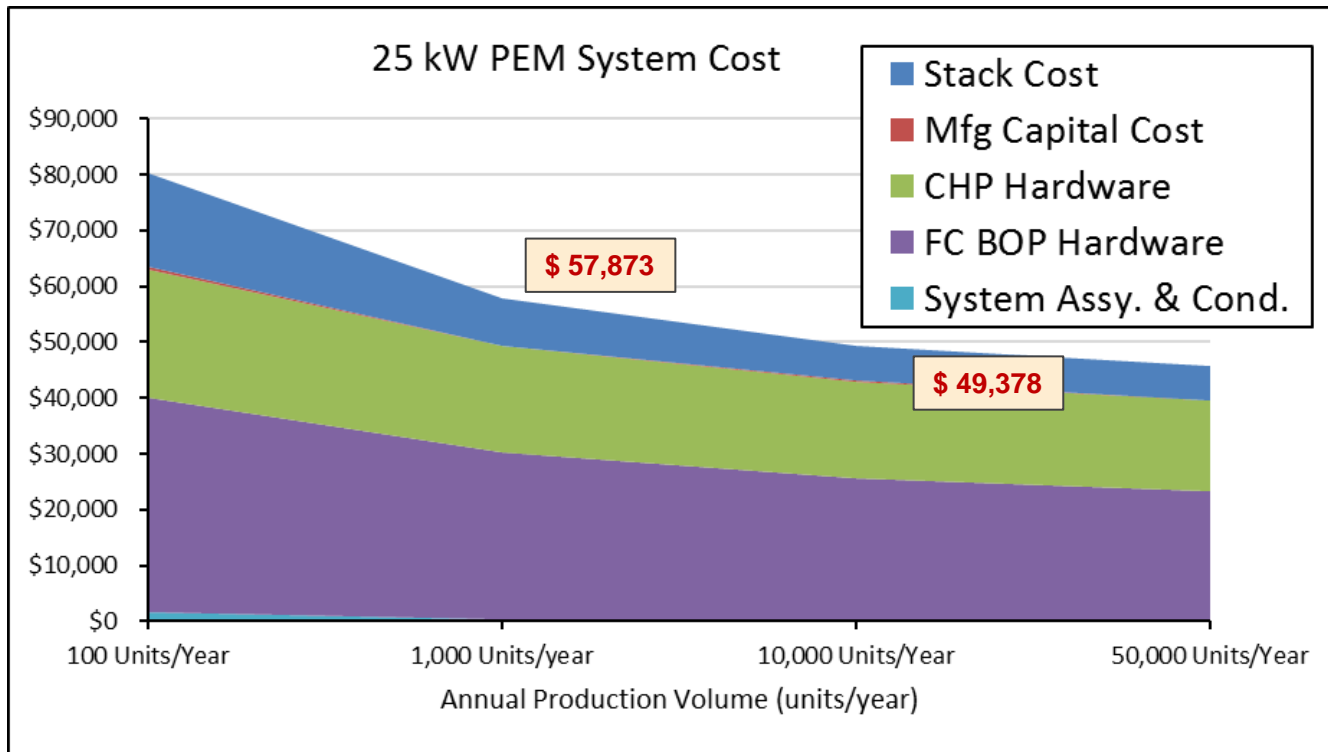

**BOP contribution to cost is even more substantial as production volume increases**

## 250-kW CHP PEM Fuel Cell System Cost Summary

Description	100 Units	1,000 Units	10,000 Units	50,000 Units
Total stack manufacturing cost, with scrap	\$70,197	\$52,589	\$50,432	\$50,009
Fuel, Water, and Air Supply Components	\$35,472	\$31,447	\$28,662	\$26,881
Fuel Processor Components	\$94,462	\$79,221	\$70,458	\$66,491
Heat Recovery Components	\$56,215	\$51,218	\$46,680	\$44,665
Power Electronic, Control, and Instrumentation Components	\$117,058	\$94,238	\$74,725	\$61,509
Assembly Components and Additional Work Estimate	\$46,840	\$42,590	\$38,340	\$34,500
<b>Total system cost, pre-markup</b>	<b>\$420,245</b>	<b>\$351,303</b>	<b>\$309,297</b>	<b>\$284,054</b>
<b>System cost per net KW, pre-markup</b>	<b>\$1,681</b>	<b>\$1,405</b>	<b>\$1,237</b>	<b>\$1,136</b>
<b>Sales markup</b>	<b>50%</b>	<b>50%</b>	<b>50%</b>	<b>50%</b>
<b>Total system cost, with markup</b>	<b>\$630,367</b>	<b>\$526,954</b>	<b>\$463,945</b>	<b>\$426,081</b>
<b>System cost per net KW, with markup</b>	<b>\$2,521</b>	<b>\$2,108</b>	<b>\$1,856</b>	<b>\$1,704</b>

**BOP dominates system cost for all capacities and volumes examined**

# 250-kW CHP PEM Fuel Cell System Cost Distribution (1,000 units per year)

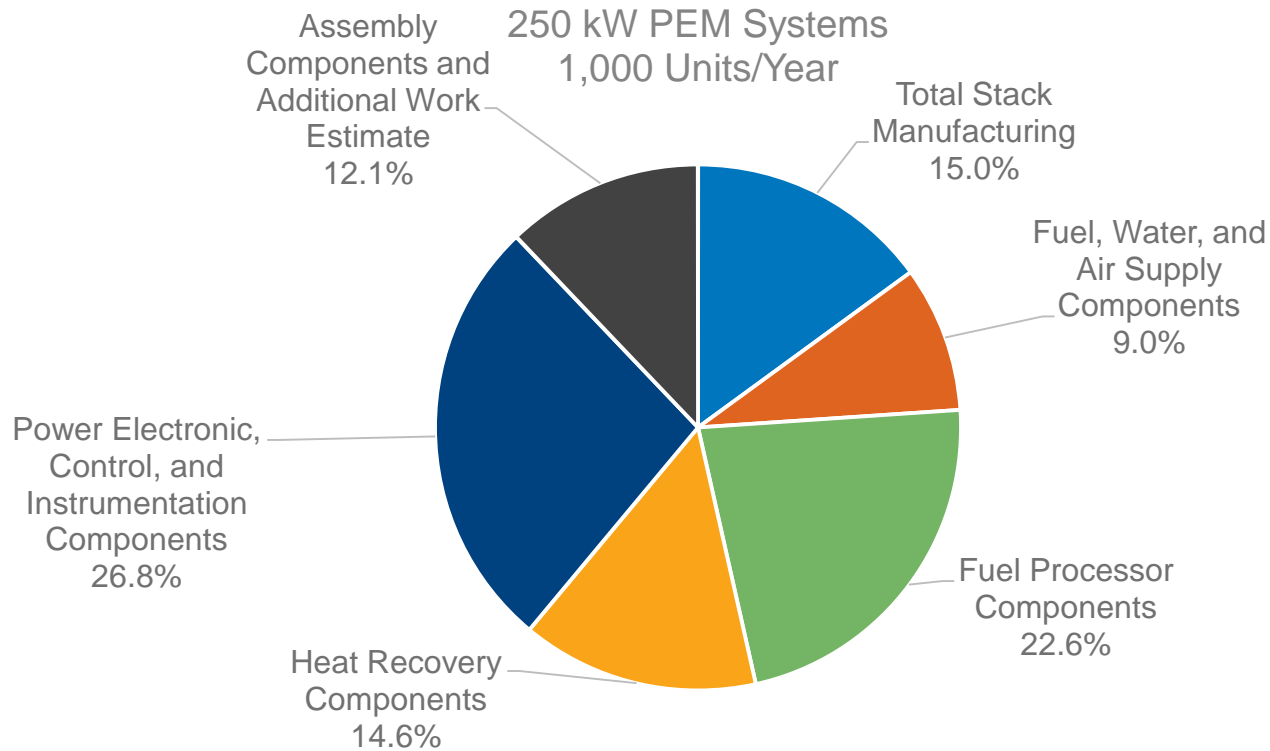



# Representative SOFC CHP system

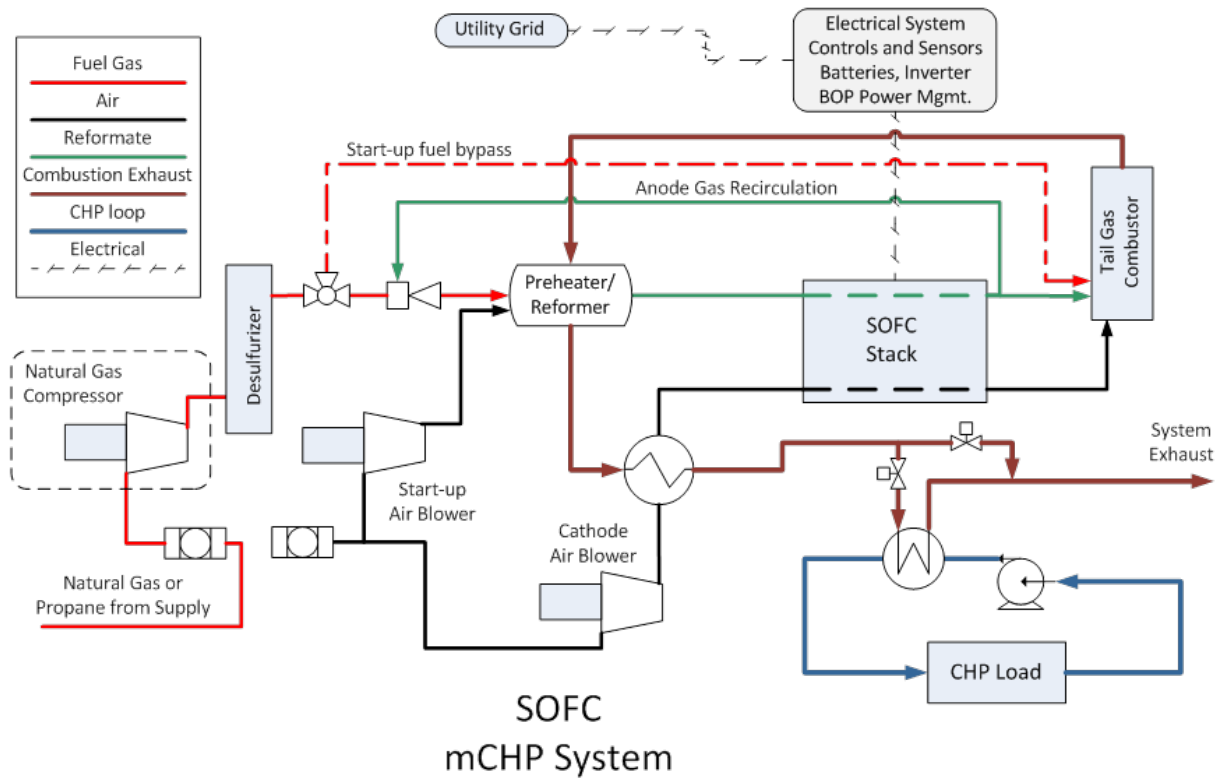

**SOFC system is less complex than the PEM system due to simpler fuel processor and less needed heat exchangers**

# 25-kW CHP SOFC BoP Cost

BoP Components	25 kW			
	100 Units (\$/each)	1000 Units (\$/each)	10,000 Units (\$/each)	50,000 Units (\$/each)
Fuel Supply	\$1,782	\$646	\$553	\$508
Fuel Processing	\$3,686	\$2,531	\$1,933	\$1,847
Start-up Air Supply (CPOX)	\$1,094	\$1,004	\$931	\$899
Cathode Air	\$816	\$735	\$661	\$641
Heat Recovery	\$2,376	\$1,881	\$1,618	\$1,532
AC Power	\$11,150	\$10,321	\$9,555	\$8,898
DC Power	\$10,638	\$7,900	\$7,283	\$6,970
Instrumentation and Control	\$2,993	\$2,346	\$2,123	\$2,006
Assembly Components	\$1,047	\$951	\$854	\$770
Additional Work Estimate	\$2,100	\$1,700	\$1,500	\$1,400
<b>BOP Total</b>	<b>\$37,682</b>	<b>\$30,014</b>	<b>\$27,011</b>	<b>\$25,471</b>

**BOP has several significant contributors—most notably, AC & DC Power – fuel processing is less significant than for PEM systems**

# 25-kW SOFC BOP Cost Distribution

- Fuel Supply
- Fuel Processing
- Start-up Air Supply (CPOX)
- Cathode Air
- Heat Recovery
- AC Power
- DC Power
- Instrumentation and Controls
- Assembly Components
- Additional Work Estimate

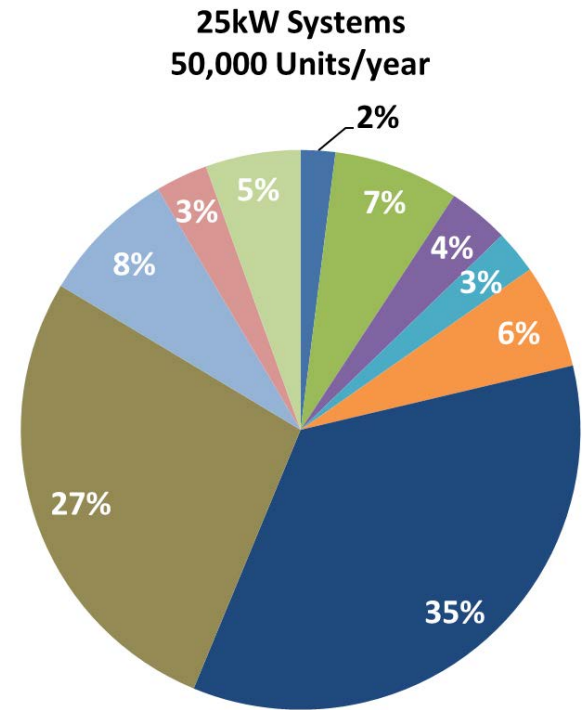
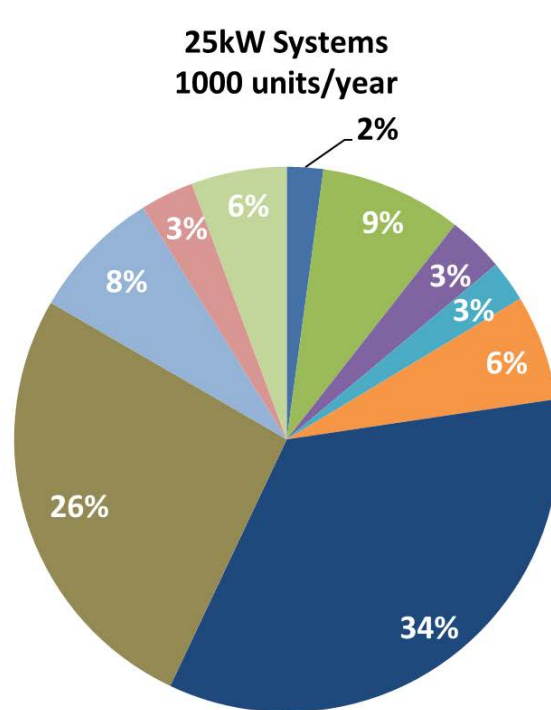

**AC & DC Power contribute even more significantly than for the PEM system as other costs are lower – a hybrid 3-port DC/AC inverter has potential to lower cost of power equipment**

# 250-kW CHP SOFC BOP Cost

BOP Components	250 kW			
	100 Units (\$/each)	1,000 Units (\$/each)	10,000 Units (\$/each)	50,000 Units (\$/each)
Fuel Supply	\$7,953	\$6,093	\$5,372	\$4,815
Fuel Processing	\$14,347	\$9,797	\$8,604	\$8,253
Air Supply	\$10,345	\$9,607	\$8,937	\$8,741
Heat Recovery	\$33,857	\$31,718	\$29,718	\$28,470
Power Electronics	\$114,436	\$91,898	\$72,617	\$59,454
Instrumentation and Control	\$ 3,526	\$ 3,152	\$2,836	\$ 2,763
Assembly Components	\$7,710	\$7,010	\$6,310	\$5,680
Additional Work Estimate	\$11,400	\$10,400	\$9,400	\$8,500
<b>BOP Total</b>	<b>\$203,575</b>	<b>\$169,675</b>	<b>\$143,793</b>	<b>\$126,677</b>

**BOP has several significant contributors—most notably, AC & DC Power – fuel processing is less significant than for PEM systems**

# 250-kW SOFC BOP Cost Distribution

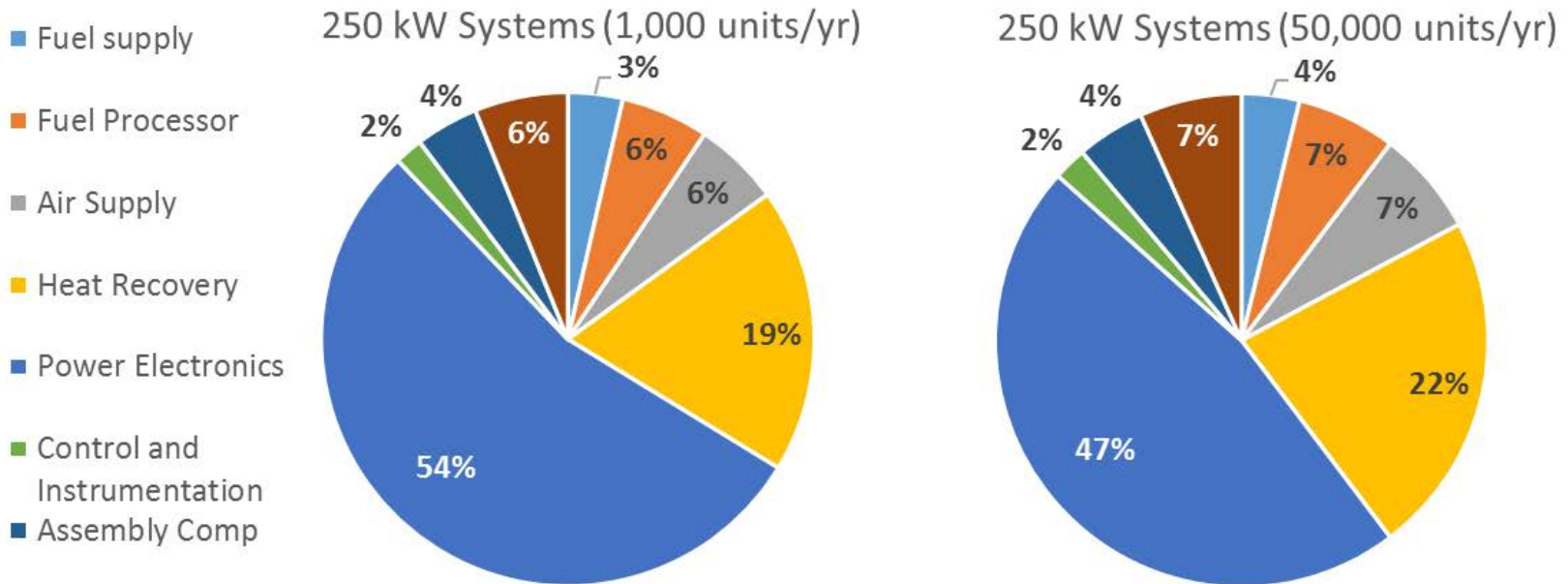

**BOP has several significant contributors, particularly for the PEM systems – most notably AC & DC Power and heat recovery – the hybrid 3-port DC/AC inverter lowers cost of power equipment, but it is still significant**

# SOFC Stack Manufacturing Cost – 25kW System

Stack Components	25 kW System			
	100 Units (\$/each)	1,000 Units (\$/each)	10,000 Units (\$/each)	50,000 Units (\$/each)
Ceramic Cells	\$4,828	\$3,395	\$2,766	\$2,650
Interconnects	\$1,109	\$870	\$495	\$444
Anode Frame	\$434	\$370	\$363	\$357
Anode Mesh	\$365	\$275	\$191	\$189
Cathode Frame	\$180	\$121	\$115	\$111
Cathode Mesh	\$380	\$286	\$199	\$196
Picture Frame	\$212	\$135	\$128	\$123
Laser Weld	\$1,444	\$168	\$112	\$112
Glass Ceramic Sealing	\$3,890	\$655	\$401	\$373
End Plates	\$822	\$720	\$644	\$643
Assembly Hardware	\$229	\$214	\$200	\$191
Assembly Labor	\$266	\$212	\$207	\$206
Stack Brazing	\$98	\$81	\$67	\$50
Test and Conditioning	\$2,589	\$856	\$668	\$656
<b>Total Cost</b>	<b>\$16,848</b>	<b>\$8,358</b>	<b>\$6,555</b>	<b>\$6,302</b>
<b>Cost per kW<sub>net</sub></b>	<b>\$674</b>	<b>\$334</b>	<b>\$262</b>	<b>\$252</b>

**Machine utilization leads to significant cost reductions for processing steps such as laser weld and sealing while ceramic cells remain high due to machine time (kiln firing process and screen printing)**

All costs include manufacturing scrap

# SOFC Fuel Cell Stack Volume Trend

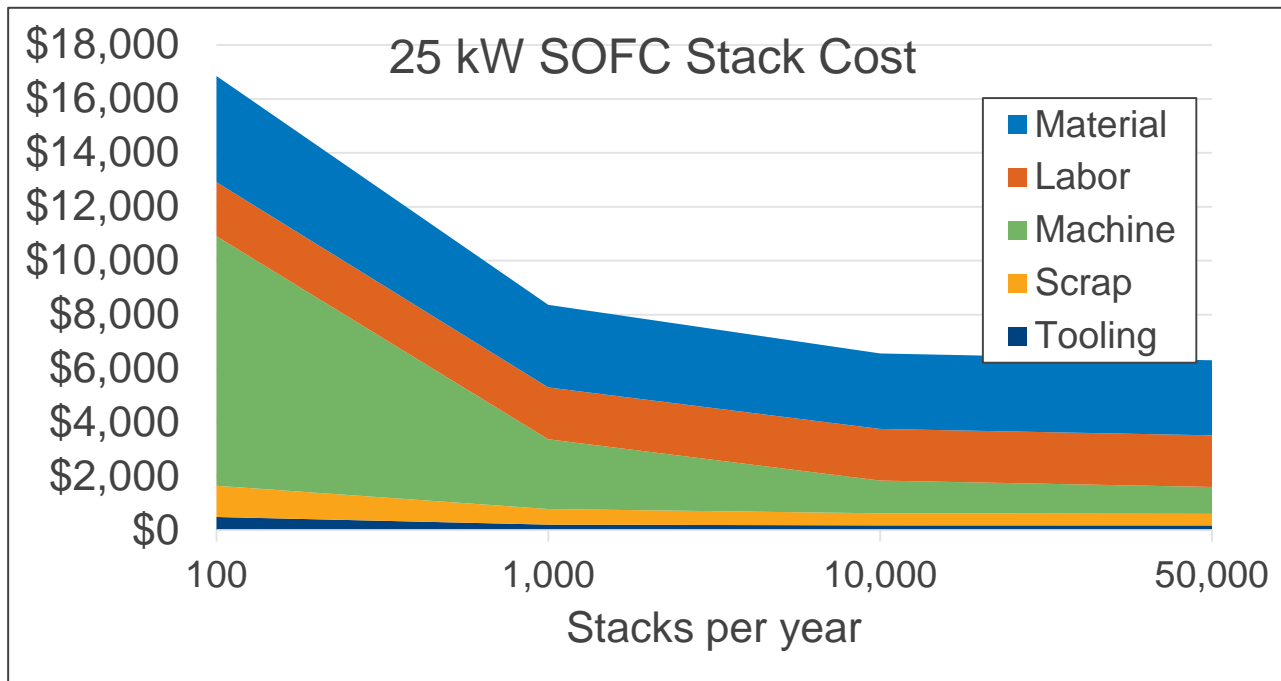

**Costs more evenly spread for SOFC Stacks between material, labor and machine costs –with machine cost dominating at low volume**

# 25 kW CHP SOFC Fuel Cell System Cost Summary

BOP Components	100 Units (\$/each)	1000 Units (\$/each)	10,000 Units (\$/each)	50,000 Units (\$/each)
Total stack manufacturing cost, with scrap	\$16,848	\$8,358	\$6,555	\$6,302
Stack manufacturing capital cost	\$748	\$209	\$135	\$126
CHP Hardware	\$23,134	\$19,433	\$17,939	\$16,939
FC BOP Hardware	\$14,548	\$10,581	\$9,073	\$8,532
System assembly, test, and conditioning	\$1,428	\$399	\$330	\$330
Total system cost, pre-markup	\$56,706	\$38,980	\$34,032	\$32,229
System cost per KW <sub>net</sub> , pre-markup	\$2,268	\$1,559	\$1,361	\$1,289
Sales Markup	50%	50%	50%	50%
Total system price, with markup	\$85,059	\$58,470	\$51,048	\$48,344
System price per KW <sub>net</sub> , with markup	\$3,402	\$2,339	\$2,042	\$1,934

**BOP dominates system cost for all capacities and volumes examined**



# 25 kW SOFC CHP System Cost - Volume Trend

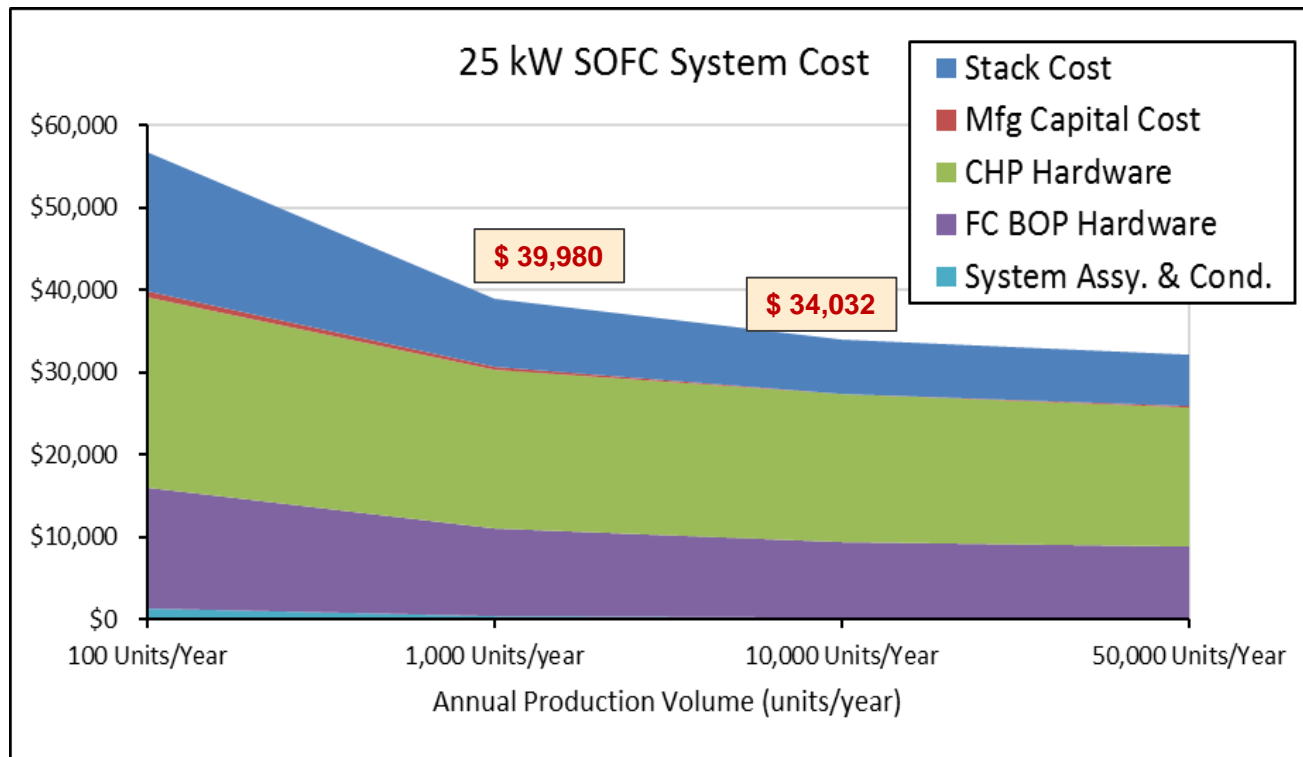

**BOP contribution to cost is even more substantial as production volume increases**

## 250-kW CHP SOFC Fuel Cell System Cost Summary

Description	100 Units	1,000 Units	10,000 Units	50,000 Units
Total stack manufacturing cost, with scrap	\$87,497	\$70,430	\$66,665	\$66,327
Fuel, Water, and Air Supply Components	\$18,298	\$15,700	\$14,309	\$13,556
Fuel Processor Components	\$14,347	\$9,797	\$8,604	\$8,253
Heat Recovery Components	\$33,857	\$31,718	\$29,718	\$28,470
Power Electronic, Control, and Instrumentation Components	\$117,962	\$95,050	\$75,453	\$62,217
Assembly Components and Additional Work Estimate	\$19,110	\$17,410	\$15,710	\$14,180
<b>Total system cost, pre-markup</b>	<b>\$291,072</b>	<b>\$240,105</b>	<b>\$210,458</b>	<b>\$193,004</b>
<b>System cost per net KW, pre-markup</b>	<b>\$1,164</b>	<b>\$960</b>	<b>\$842</b>	<b>\$772</b>
Sales markup	50%	50%	50%	50%
<b>Total system cost, with markup</b>	<b>\$436,608</b>	<b>\$360,157</b>	<b>\$315,686</b>	<b>\$289,505</b>
<b>System cost per net KW, with markup</b>	<b>\$1,746</b>	<b>\$1,441</b>	<b>\$1,263</b>	<b>\$1,158</b>

**BOP dominates system cost for all capacities and volumes examined**

# CHP Fuel Cell System Cost Comparison

25 kW PEM Systems  
1000 units/year

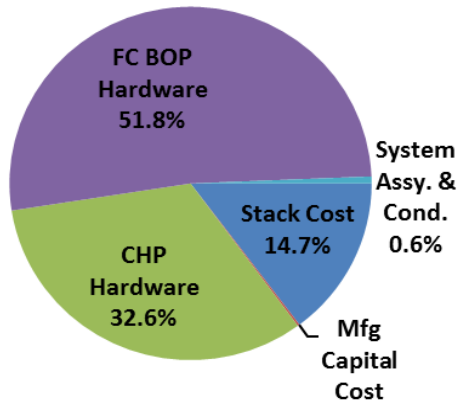

25 kW SOFC Systems  
1000 units/year

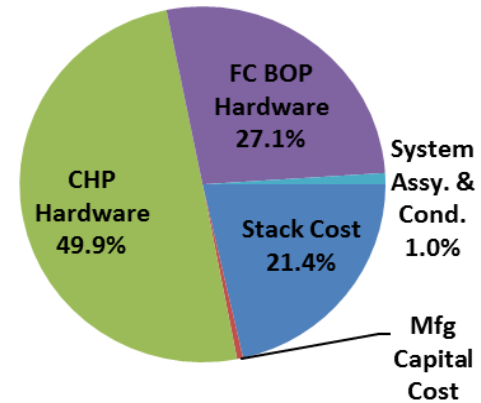

For both technologies, BOP (including CHP hardware) dominates – more significant for the PEM systems

# 250-kW PEM and SOFC system costs at 1,000 units per year

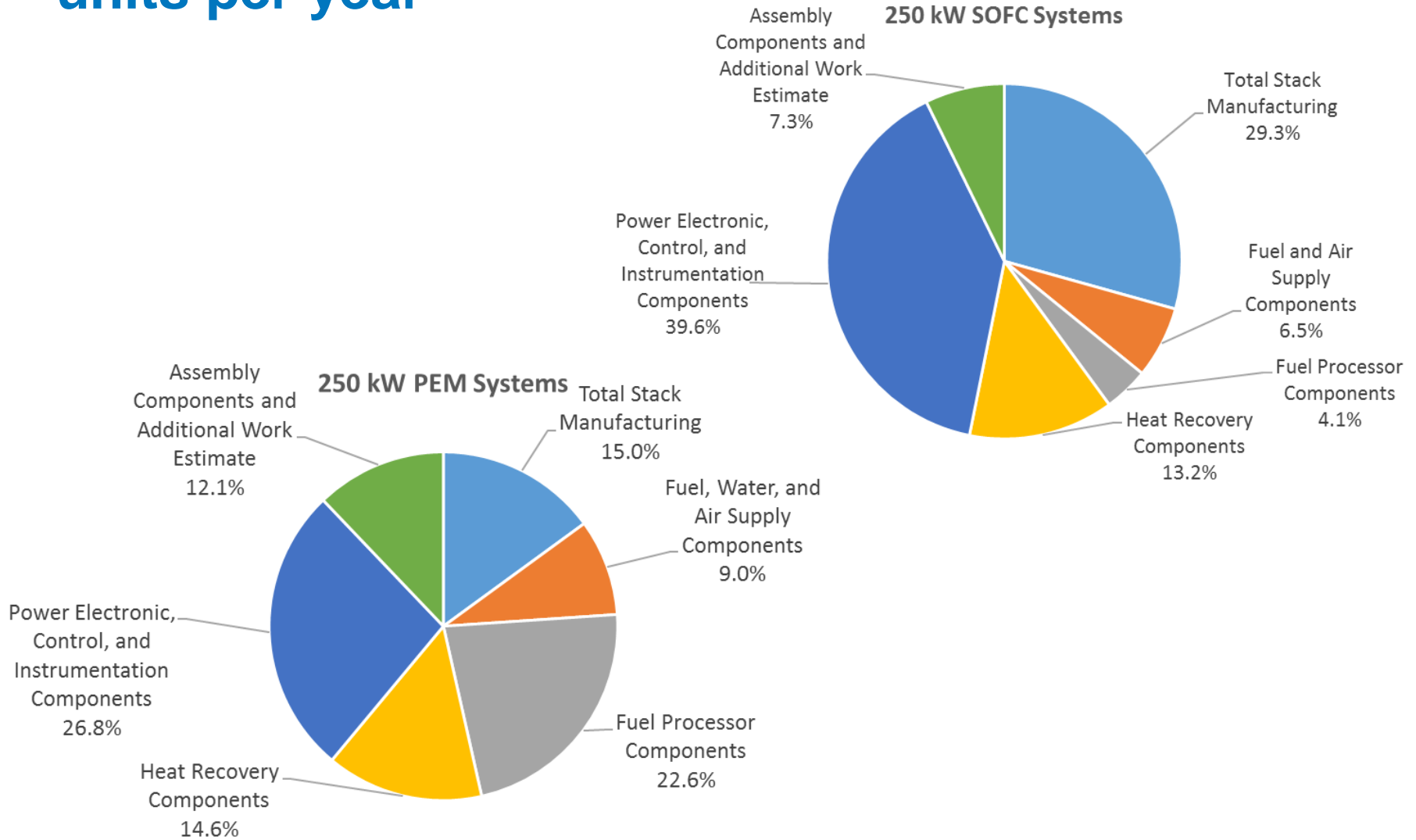

# Sensitivity Analysis: 100-kW PEM Systems

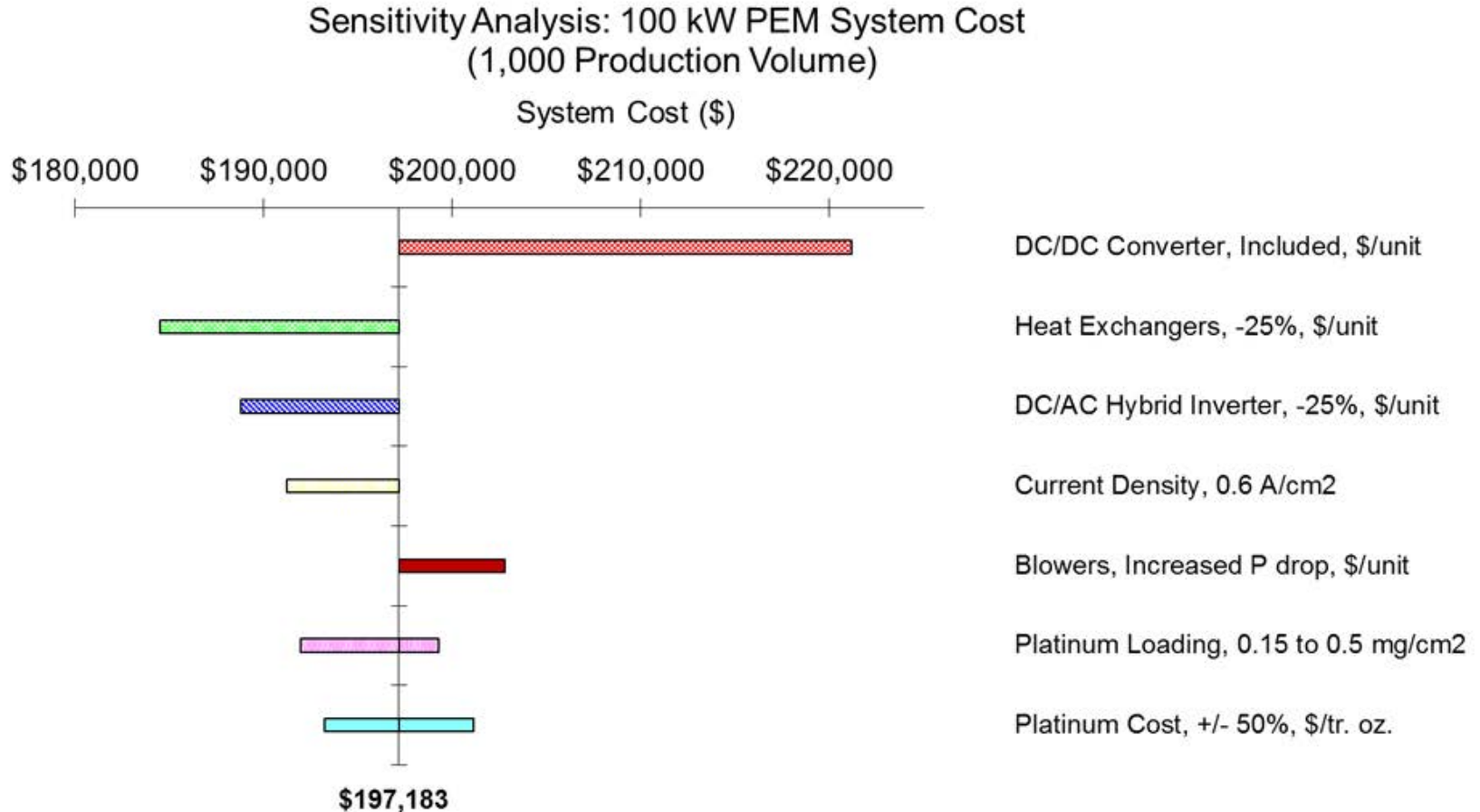

# Sensitivity Analysis: 100-kW SOFC Systems

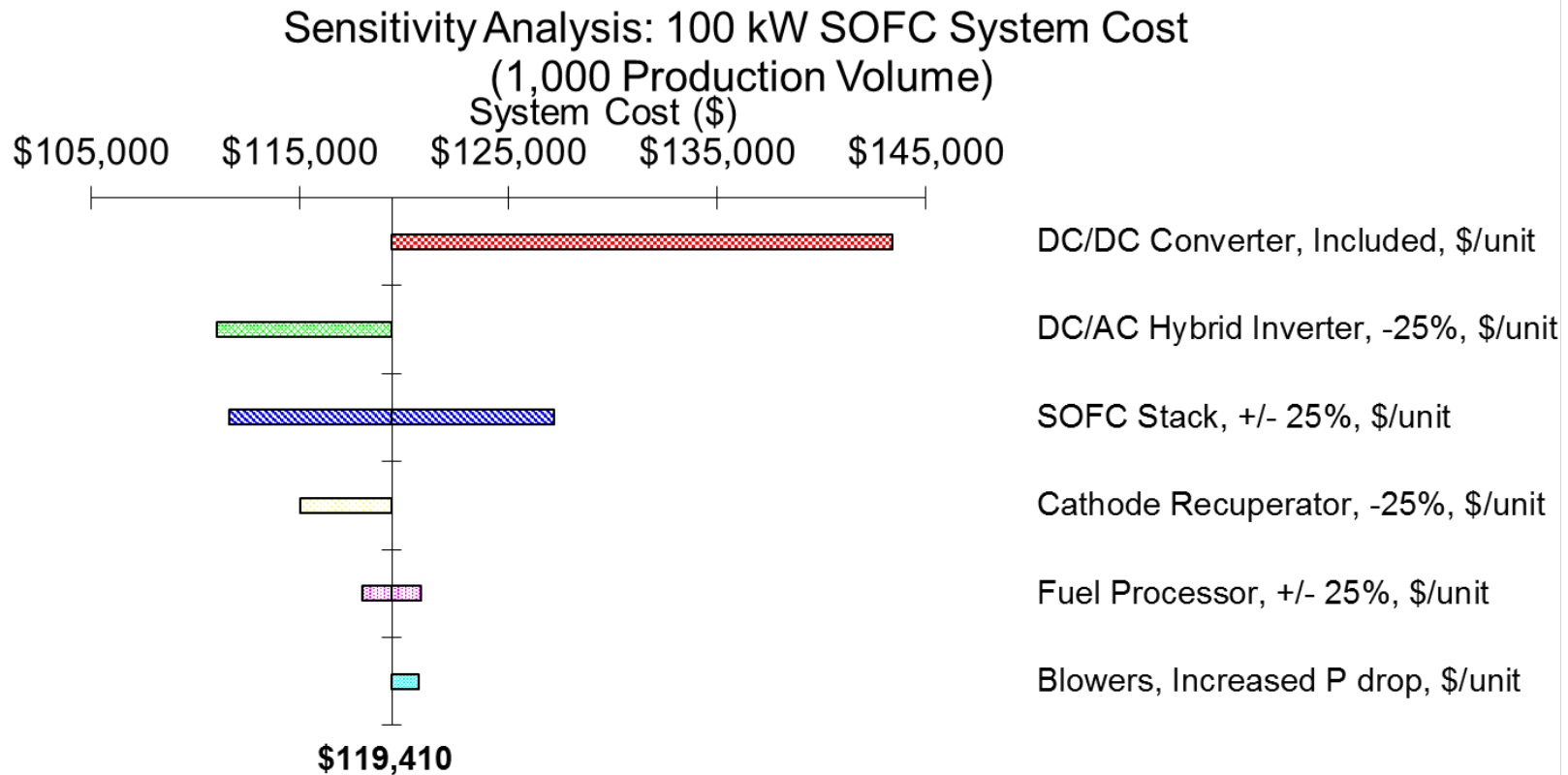

## Summary

- BOP dominates system cost
- Within BOP, hardware directly related to connecting to the grid represents major portion of cost for both PEM and SOFC systems
- Recently developed hybrid inverters eliminate need for separate DC/DC Converter – though power electronics still represent the highest cost system component
- Heat exchangers, particularly high temperature, also represent a major portion of the BOP
- Attractive value proposition shown for locations where electricity prices are high and natural gas prices low
- For greater detail on these studies, please refer to the reports posted on the DOE EREE website.

***BATTELLE***

**It can be done**



# Backup Slides

# Seven-tube 250-kW reformer configuration and three-tube 100-kW reformer configuration

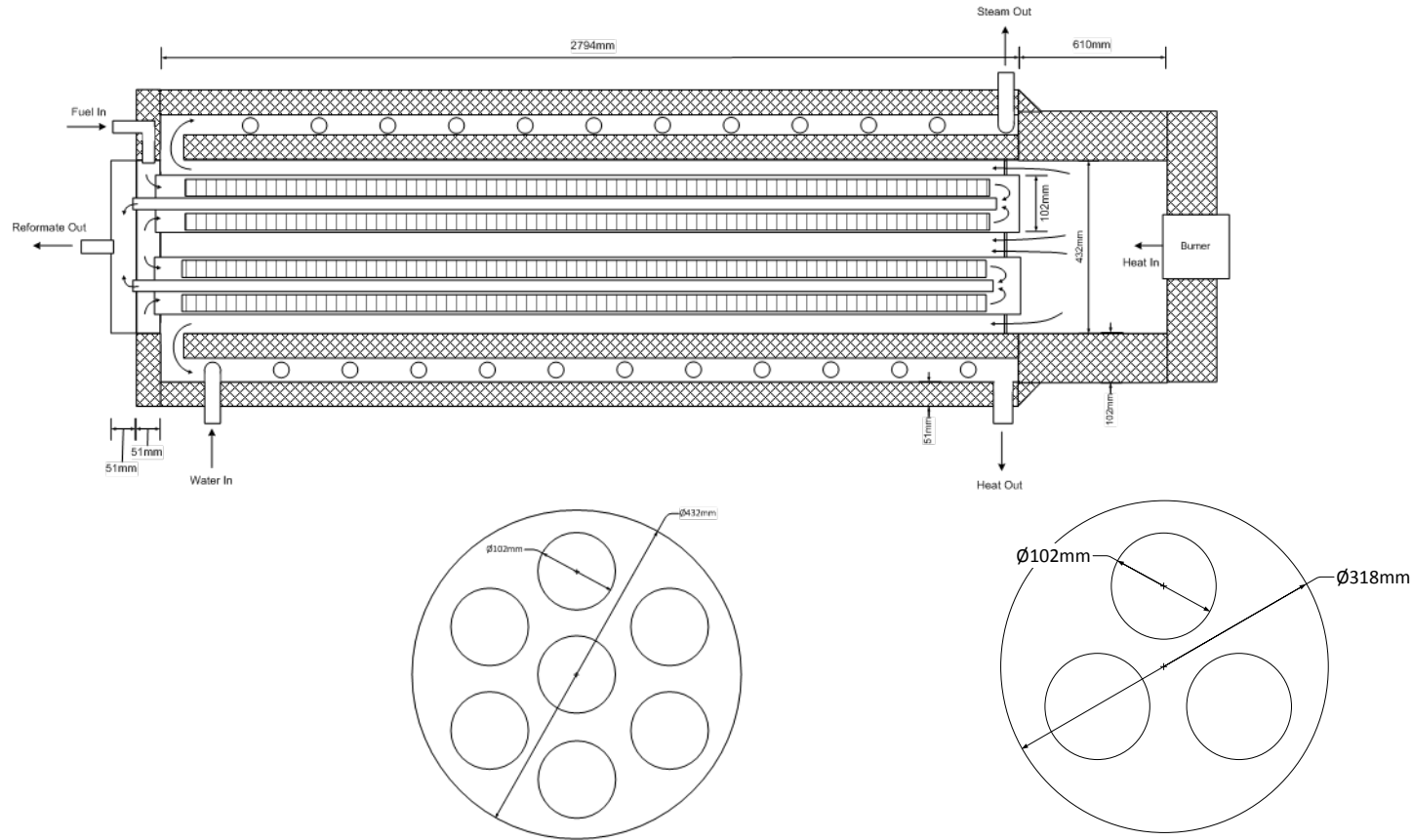

# CHP PEM Fuel Cell System Cost Comparison

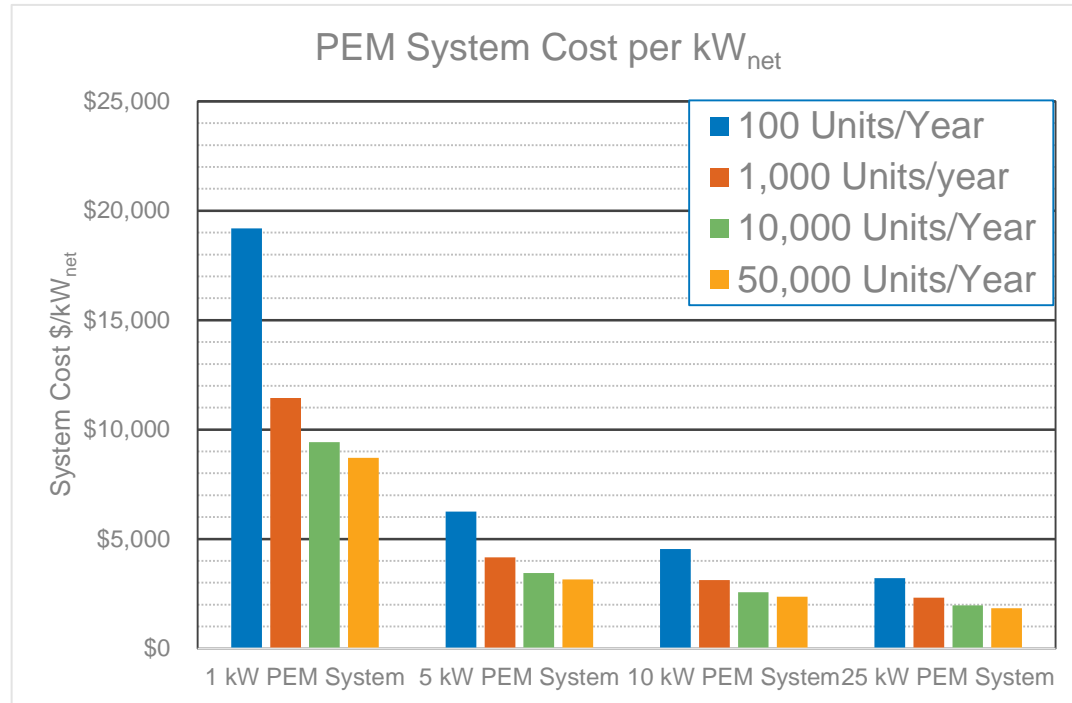

# CHP SOFC Fuel Cell System Cost Comparison

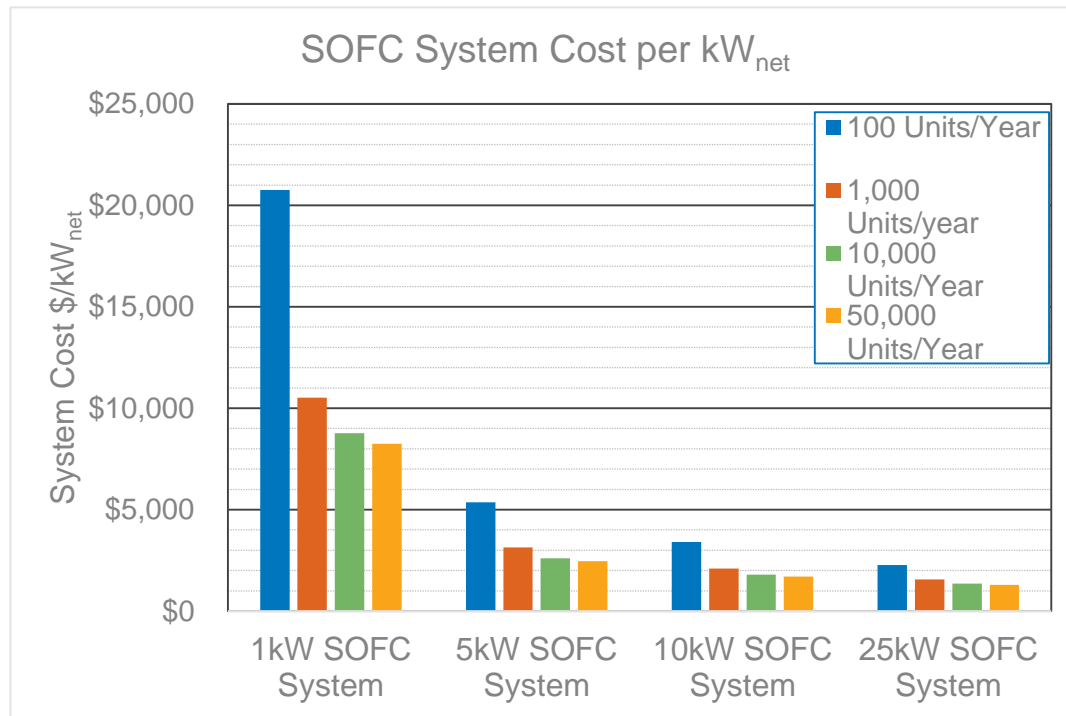

# PEM Fuel Cell Design Parameters

Parameter	1 kW	5 kW	10 kW	25 kW
Power Density (W/cm <sup>2</sup> )	0.27			
Current Density (A/cm <sup>2</sup> )	0.4			
Cell Voltage (VDC)	0.68			
Active Area Per Cell (cm <sup>2</sup> )	200		400	
Net Power (kW)	1	5	10	25
Gross Power (kW)	1.2	6	12	30
Number of Cells (#)	22	110	110	276
Full Load Stack Voltage (VDC)	15	75	75	188
Membrane Base Material	PFSA, 0.2mm thick, PTFE reinforced			
Catalyst Loading	0.4 mg Pt/cm <sup>2</sup> (total) Cathode is 2:1 relative to Anode			
Catalyst Application	Catalyst ink prepared, slot die coating deposition, heat dried, decal transfer			
Gas diffusion layer (GDL) Base Material	Carbon paper 0.2 mm thick			
GDL Construction	Carbon paper dip-coated with PTFE for water management			
Membrane electrode assembly (MEA) Construction	Hot press and die cut			
Seals	1 mm silicone, infection molded			
Stack Assembly	Hand assembled, tie rods			
Bipolar Plates	Graphite composite, compression molded			
End Plates	Die cast and machined A356 aluminum			

## SOFC Fuel Cell Design Parameters

Parameter	1 kW	5 kW	10 kW	25kW
Cell Power Density (W/cm <sup>2</sup> )	0.32			
Cell Current Density (A/cm <sup>2</sup> )	0.4			
Cell Voltage (VDC)	0.7			
Active Area Per Cell (cm <sup>2</sup> )	200	200	400	400
Rated Net Power (kW, continuous)	1	5	10	25
Rated Gross Power (kW, continuous)	1.2	6	12	30
Number of Cells (#)	21	107	107	268
Open Circuit Voltage (VDC)	24	118	118	295
Full Load Stack Voltage (VDC)	15	75	75	188
Cell Design	Planar, Anode supported			
Anode Material	Ni-8YSZ, 250 μm thick			
Anode Application	Tape cast, kiln fire			
Anode Active Layer Material	NI-YSZ, 15 μm thick			
Anode Active Layer Application	Screen Print, kiln fire			
Anode Contact Layer Material	NI-YSZ, 10 μm thick			
Anode Contact Layer Application	Screen Print, kiln fire			
Electrolyte Material	8YSZ, 8 μm thick			
Electrolyte Application	Screen print, kiln fire			

# SOFC Fuel Cell Design Parameters

Parameter	
Cathode Active Layer Material	YSZ/LSM, 5 $\mu$ m thick
Cathode Active Layer Application	Screen Print, kiln fire
Cathode Material	LSCF, 30 $\mu$ m thick
Cathode Application	Screen Print, kiln fire
Cathode Contact Layer Material	LSM/YSZ, 10 $\mu$ m thick
Cathode Contact Layer Application	Screen Print, kiln fire
Seals	Wet application bonded glass/ceramic
Stack Assembly	Hand Assembled, tie rods, furnace brazed
Interconnects	Ferritic Stainless Steel (SS-441) with Perovskite coating, 2-3 $\mu$ m thick
End Plates	Die Cast and Machined A560 Steel

# Primary Power/CHP Electrical System Schematic

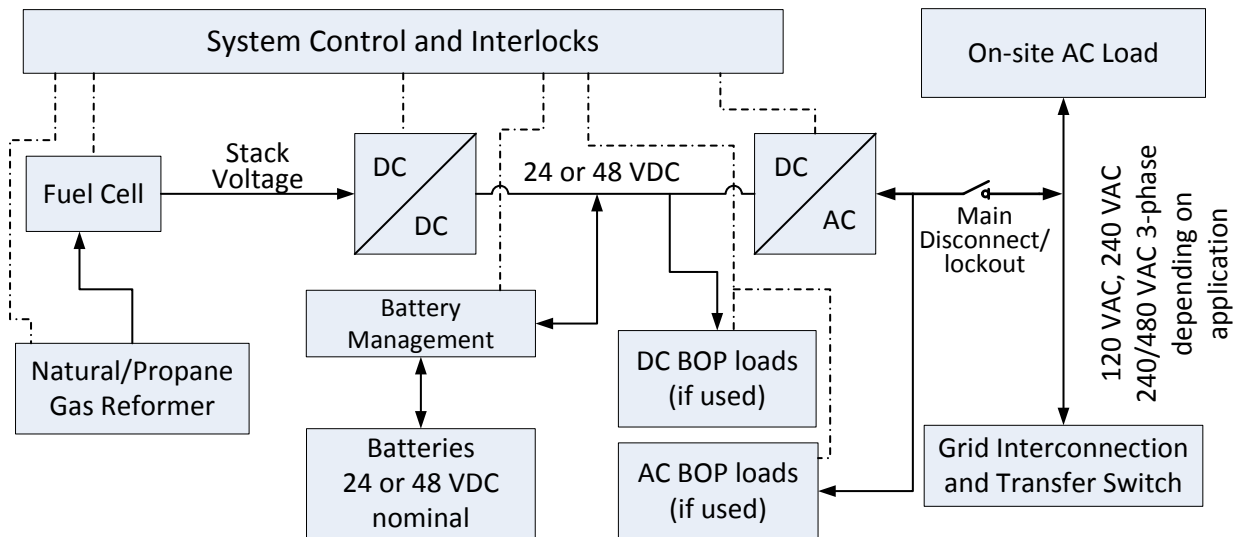



# Life Cycle Cost Analysis Assumptions – Restaurant in Southern California

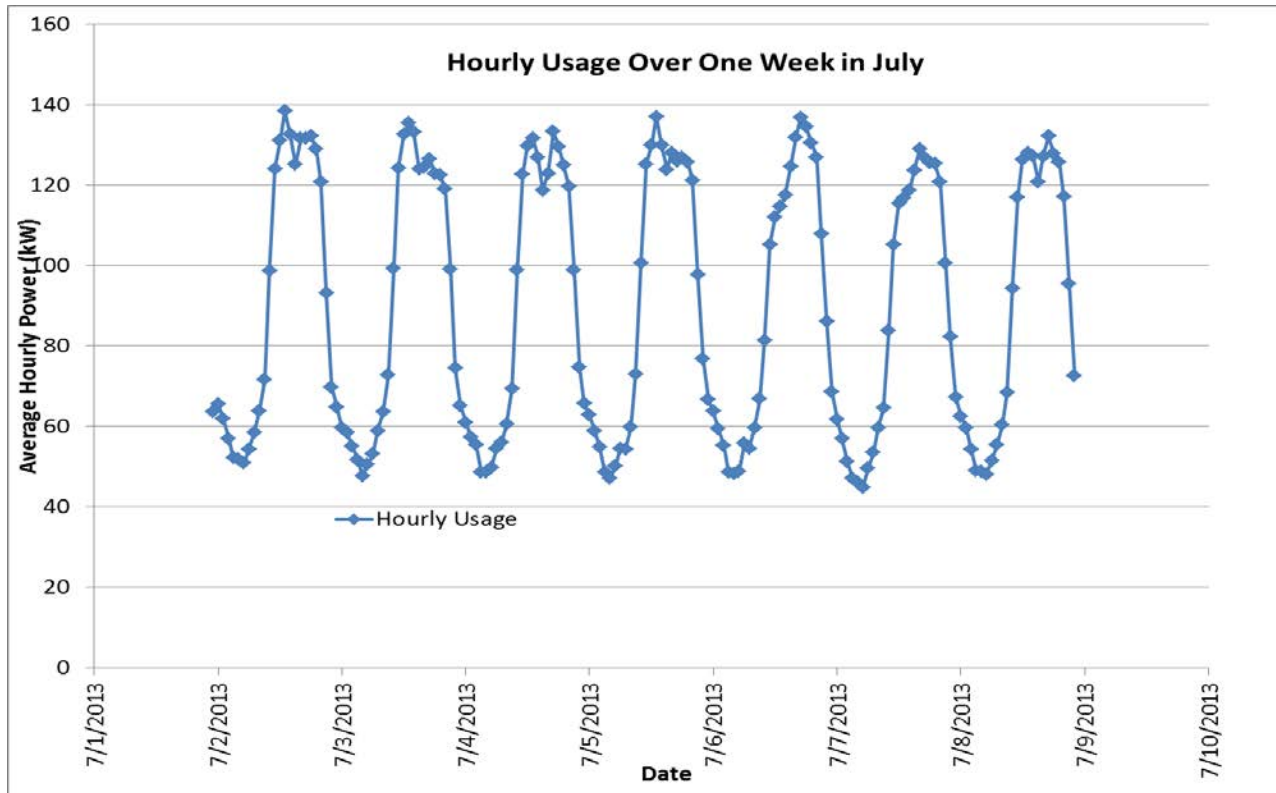

# Life Cycle Cost Analysis – 25kW System

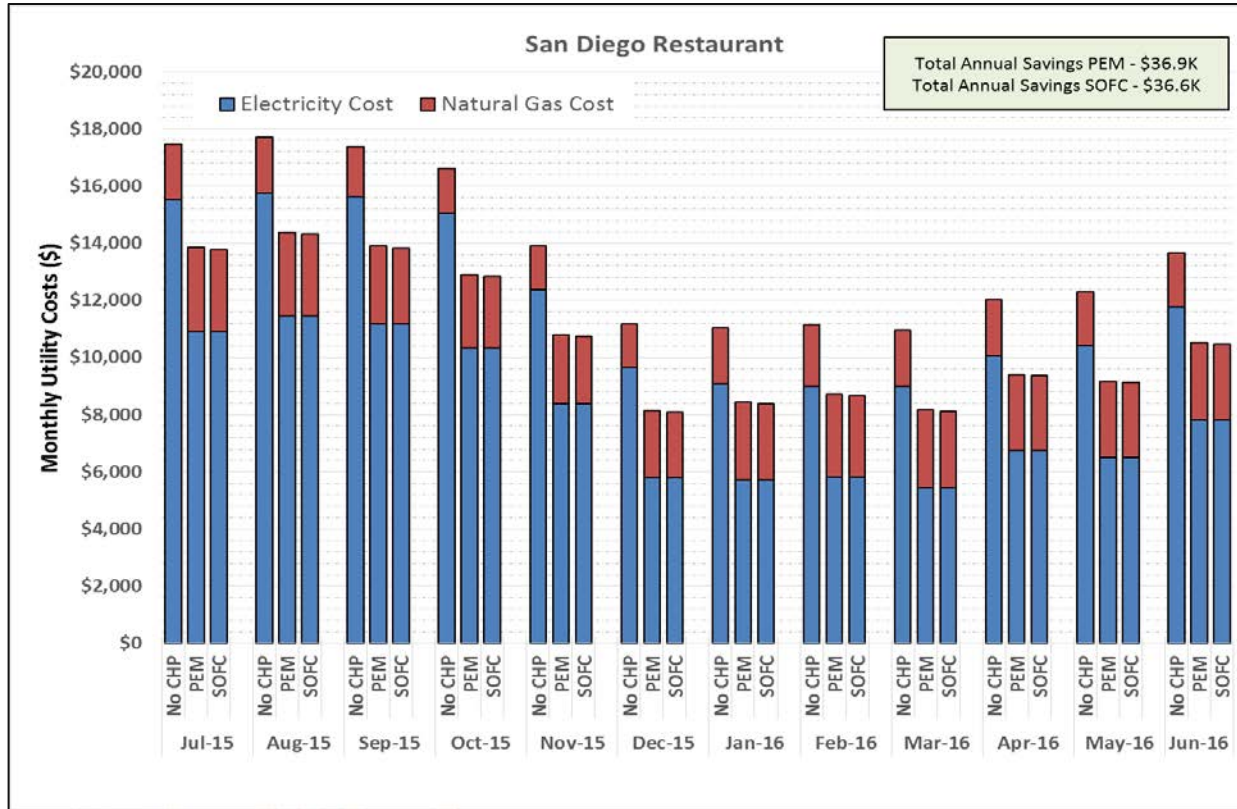

**Significant annual savings on utilities for San Diego restaurant due to high electricity costs**

# Life Cycle Cost Analysis – 25kW System

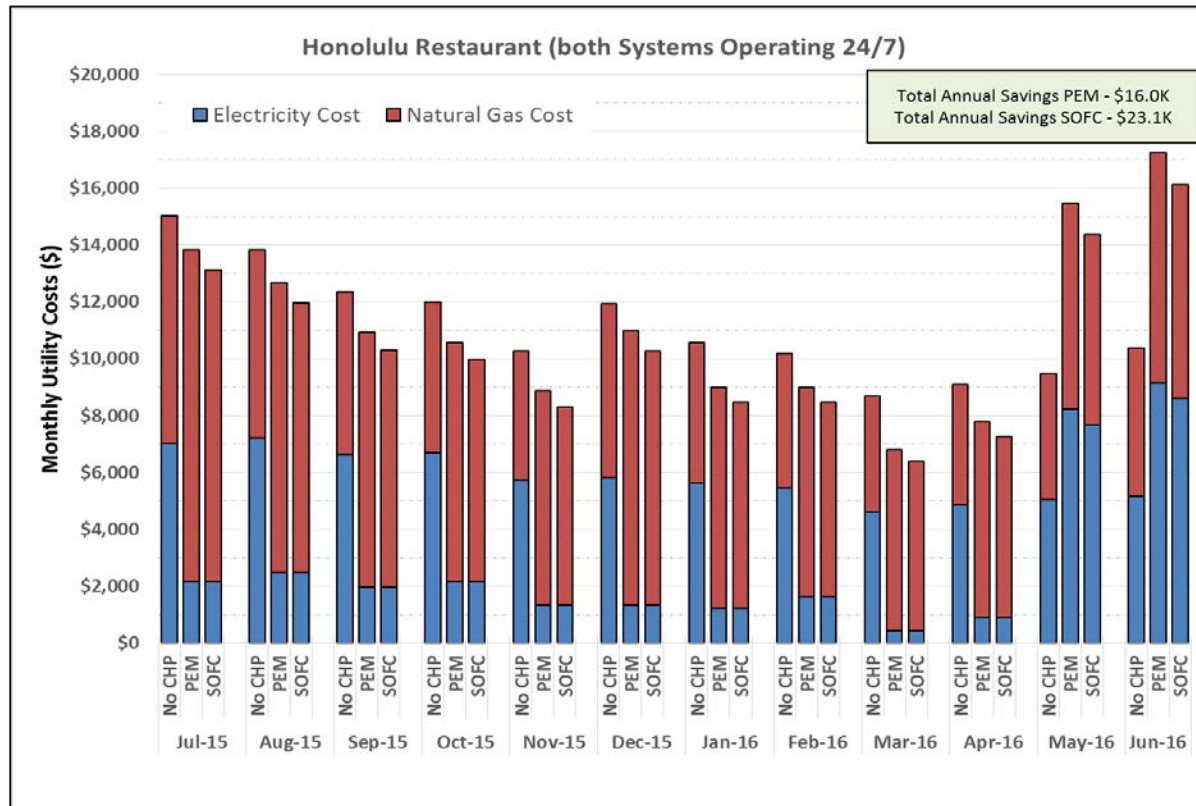

Even with high cost of natural gas in Hawaii, still significant savings resulting from CHP system is heat load is substantial

# Life Cycle Cost Analysis – 25kW System

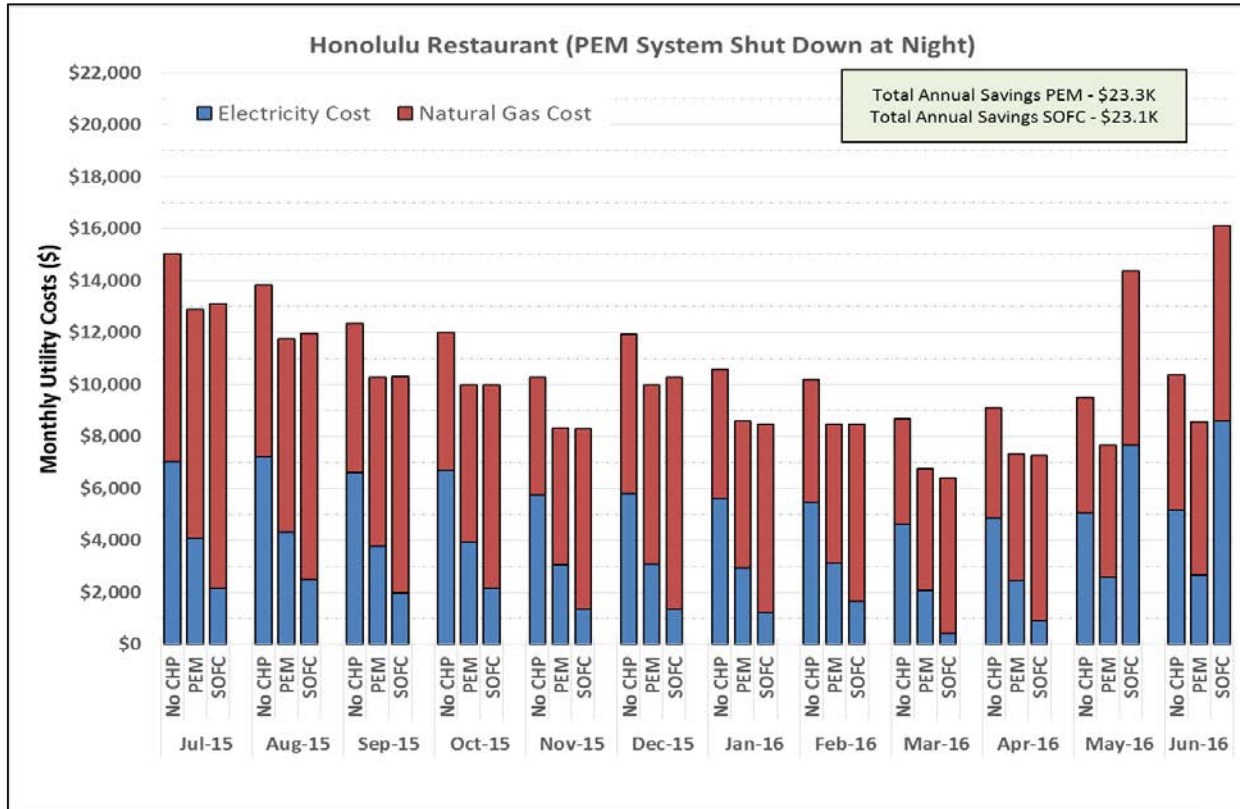

**PEM systems benefit even more from shutting down when the restaurant is not open for business**

# Life Cycle Cost Analysis

PEM – 1,000 units/year	Fuel Cell	Utilities Only
Cost of System	\$86,809	N/A
Installation Cost	\$10,000	N/A
Annual Cost of Capital (10%)	\$24,683	N/A
Annual Consumables	\$1,252	N/A
Annual O & M Costs	\$750	N/A
Annual Electricity Utility Cost	\$96,028	\$143,226
Annual Gas Utility Cost	\$32,373	\$22,184
Annual Total	\$155,087	\$165,410
Annual Savings	\$10,323	

SOFC – 1,000 units/year	Fuel Cell	Utilities Only
Cost of System	\$58,470	N/A
Installation Cost	\$10,000	N/A
Annual Cost of Capital (10%)	\$17,457	N/A
Annual Consumables	\$521	N/A
Annual O & M Costs	\$750	N/A
Annual Electricity Utility Cost	\$96,028	\$135,427
Annual Gas Utility Cost	\$31,663	\$26,290
Annual Total	\$146,420	\$161,717
Annual Savings	\$18,990	

PEM – 10,000 units/year	Fuel Cell	Utilities Only
Cost of System	\$74,067	N/A
Installation Cost	\$10,000	N/A
Annual Cost of Capital (10%)	\$21,434	N/A
Annual Consumables	791.15	N/A
Annual O & M Costs	\$750	N/A
Annual Electricity Utility Cost	\$96,028	\$143,226
Annual Gas Utility Cost	\$32,373	\$22,184
Annual Total	\$151,377	\$165,410
Annual Savings	\$14,033	

SOFC – 10,000 units/year	Fuel Cell	Utilities Only
Cost of System	\$51,048	N/A
Installation Cost	\$10,000	N/A
Annual Cost of Capital (10%)	\$15,586	N/A
Annual Consumables	\$460	N/A
Annual O & M Costs	\$750	N/A
Annual Electricity Utility Cost	\$96,028	\$135,427
Annual Gas Utility Cost	\$31,663	\$26,290
Annual Total	\$144,487	\$161,717
Annual Savings	\$20,922	

**Annual savings after all costs are taken into consideration**

\*Annual cost comparison when using CHP system in San Diego Restaurant with a Production Volume of 1,000 or 10,000 Units per Year

# Life Cycle Cost Analysis

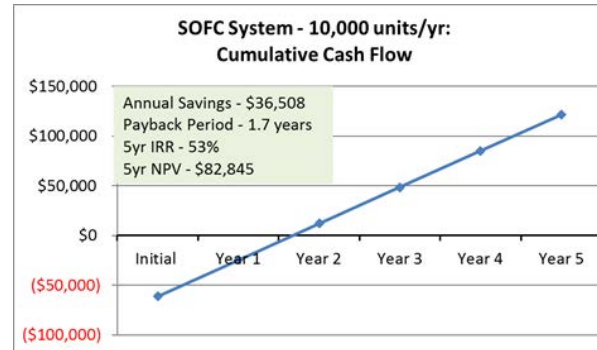
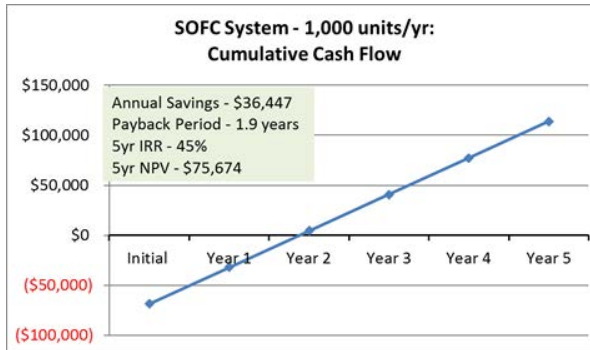
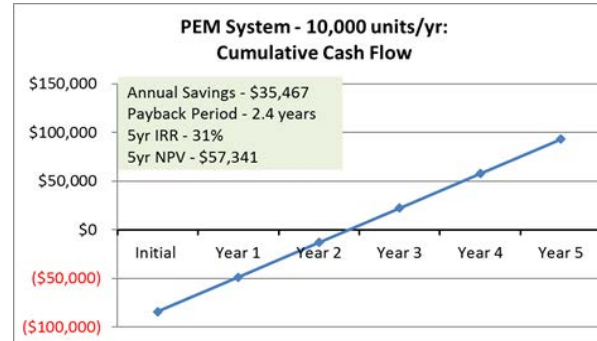
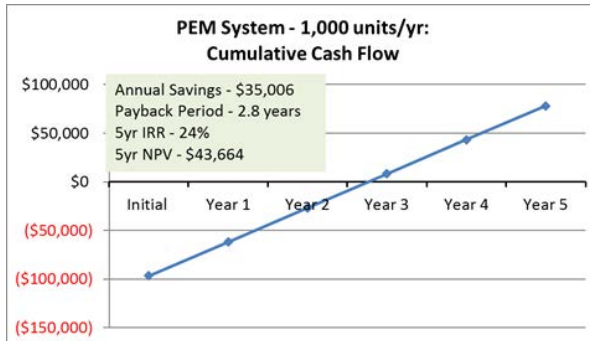

**Favorable payback period and return on investment –  
but does require significant production volumes**

\*Cumulative cash flows for PEM and SOFC systems with production volumes of 1,000 and 10,000 units/year in the San Diego store