



U.S. DEPARTMENT OF
ENERGY

Nuclear Energy

**Office Of Nuclear Energy
Sensors and Instrumentation
Annual Review Meeting**

**High Spatial Resolution Distributed Fiber-Optic Sensor
Networks for Reactors and Fuel Cycle**

**Kevin P. Chen
University of Pittsburgh, Corning Inc, and Westinghouse
Electric Company
NEET Program**

October 12-13, 2016



Project Overview

■ Goal, and Objectives

- Develop new optical fibers for nuclear industry
- Explore and demonstrate distributed multi-functional fiber optical sensors for nuclear industry
 - $\mu\epsilon$, T, vibration, P, level, chemical, **and radiation** with high spatial resolutions
- Evaluate various distributed sensing schemes and demonstrate unique capability
- Develop manufacturing schemes for sensor-fused smart parts for nuclear industry.
- Evaluate fiber sensors for extreme harsh environments (neutron radiation).

■ Participants

- University of Pittsburgh: Dr. Kevin P. Chen (PI), Zsolt Poole, Aidong Yan, Rongzhang Chen, and Mohamed Zaghoul
- Westinghouse Electrical Company: Dr. Michael Heibel, Dr. Robert Flammang, and Melissa Walter
- Corning Inc.: Dr. Ming-Jun Li and Jeffrey Stone

■ Schedule:

- Year 1: active fiber sensing technique developments, multi-functional fiber fabrications
- Year 2: distributed pressure and temperature measurements in radiation environments
- Year 3: distributed hydrogen sensing in radiation environments



Project Overview

■ What is unique about fiber optical sensors?

- Resistant to harsh environments (but no all environments).
 - High Temperature up to 800C, high pressure up to 2500 psi, gamma radiation (MGy).
 - High neutron radiation (to be evaluated)
- Fully embeddable into concrete, metal, and existing infrastructures
- Unique capability to perform distributed measurements with high spatial resolution (1-10cm)

■ What is unique about nuclear applications?

- Radiation (but no all environments are extremely radioactive)
- Need perform a wide arrange of measurements beyond temperature and strains

	Spent Nuclear Fuel Pool	Containment Dome	Steam Generator	Research Facilities (LHC, LMJ, ITER)
				
Normal Operation Radiation	2 mGy/hr	50 µGy/hr	<10 mGy/hr	50 Gy/day
Normal Operation 20-yr Dosage (Gy)	350 Gy	8.8 Gy	1.75 kGy	200 kGy
Post-Accident Radiation (Gy/hr)	2 Gy/hr	5Gy/hr	5 Gy/hr	N/A
Post-Accident 30-day Dosage (Gy)	1.44 kGy	3.7 kGy	3.7 kGy	N/A



Research Approach

■ Fibers

- Developing new optical fibers with built-in capability to perform distribution radiation measurements (for measurements and for calibration)
- Developing new multi-functional optical fibers for multiple parameter measurements

■ Sensing Technology

- Evaluate various distributed sensing schemes (Rayleigh, Brillouin, FBGs) under radiation for short and long terms measurements
- Develop new distributed sensing technology beyond T/strain measurements
 - Liquid levels
 - Pressure and T simultaneously + radiation
 - Chemical (hydrogen) and spatially resolved chemical reaction
 - Fiber optical vibration sensing for radiation environments

■ Implementations and Applications in Nuclear Engineering

- Smart parts manufacturing: Fiber embedding and testing
- New sensor platforms (smart cable, small concrete, and ...?)



Experiment Setup



- γ radiation: max. ~ 5000 Gy/hr on fibers
- Performed in Westinghouse Churchill facility
- Brillouin OTDR schemes and Rayleigh OFDR distributed sensing scheme
- Fiber Bragg gratings and fiber acoustic sensors

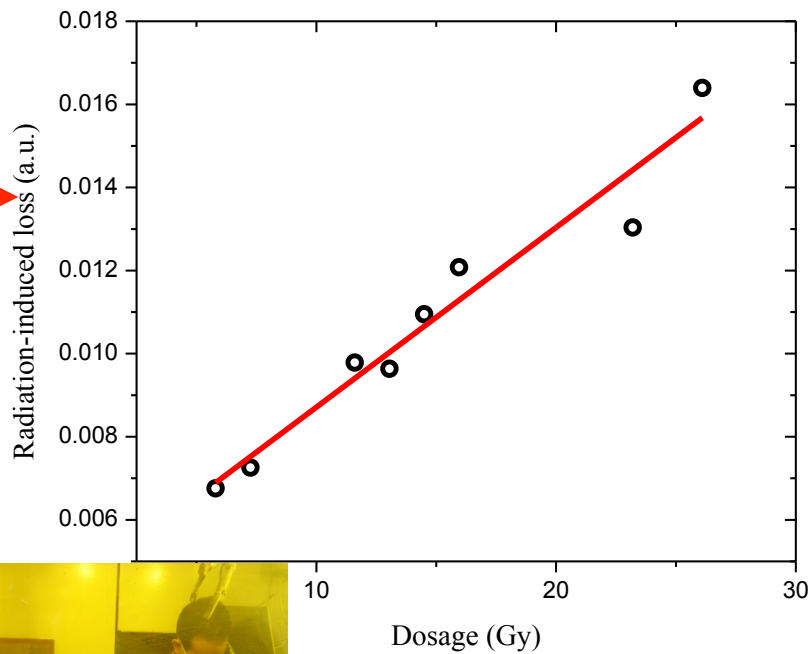
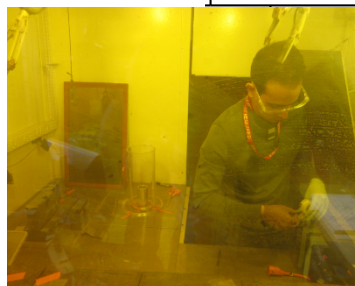
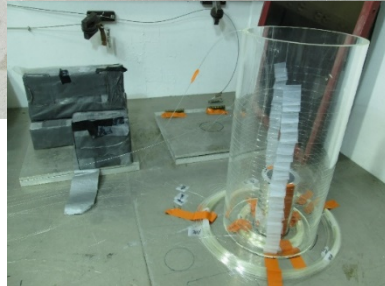
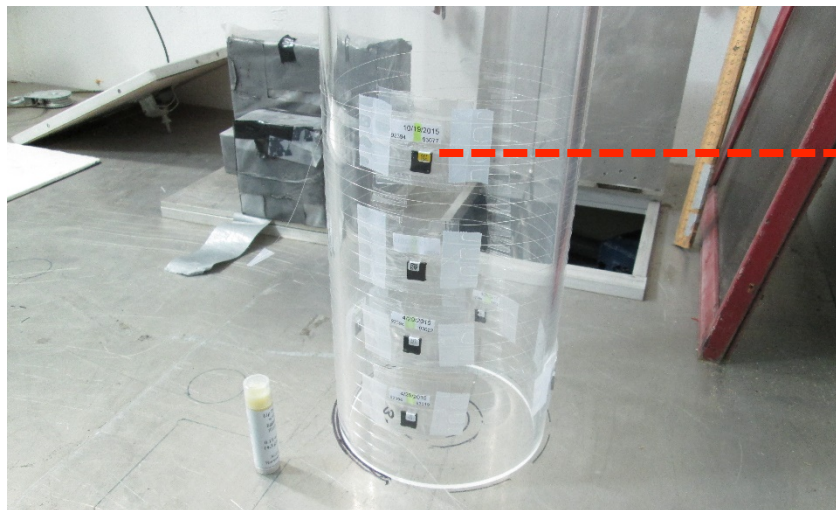



Experiment Setup



- LUNA OBR 4600
- Swept wavelength interferometry
- Compares (with cross correlation) backscattering vs. reference to determine **loss**, temperature, and strain



- ☐ Polariz. Beam Splitter
- ∞ Polariz. Controller
- 50/50 Coupler

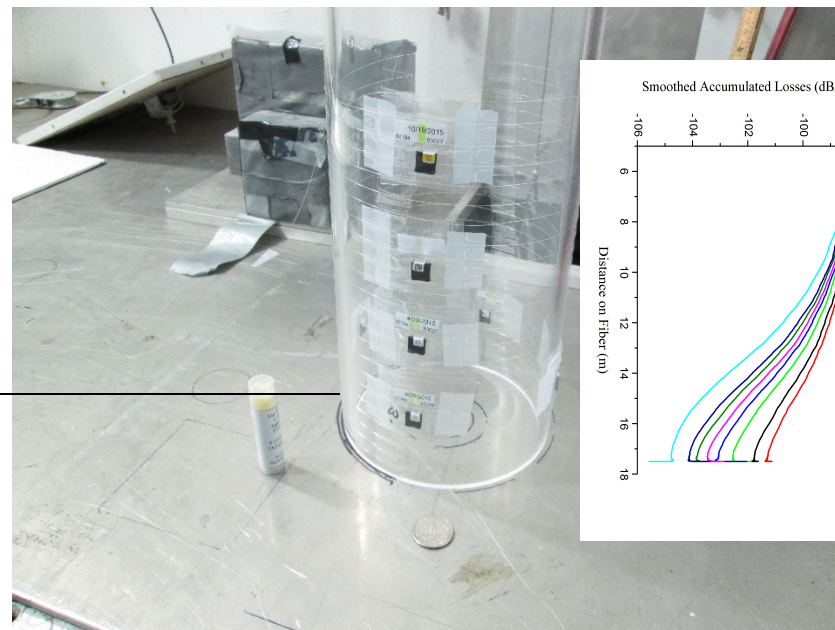
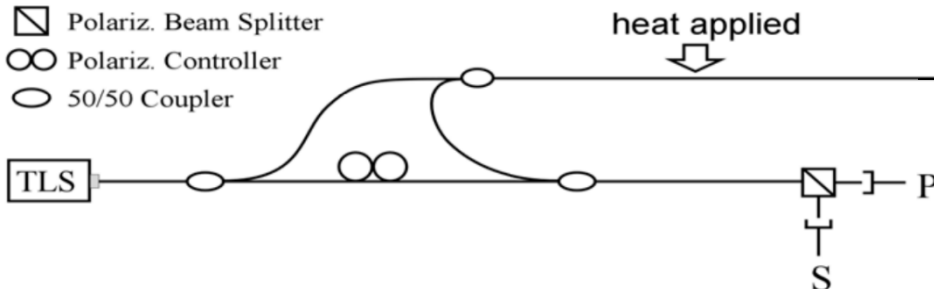



Radiation Tests

Radiation Tests

Fiber Types	SMF28	Vascade	High Ge-	Alumina	Random air-hole
RIA (dB/km)	96	61	115	35651	51

- 1MGy γ dosage (Co-60 source)
- SMF-28 standard optical fiber
- Vascade: Corning ultra-low loss, pure silica core/F-doped cladding
- Random air-hole: new all silica fiber
 - Random air-hole cladding (low cost)
 - All silica structures (sustain >400C more than F-doped fibers)

Random Air Holes Fiber

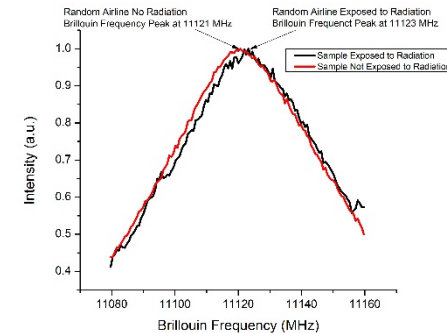
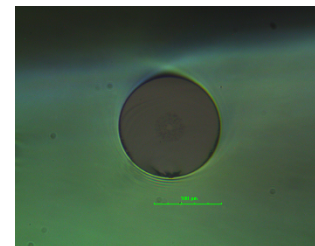

Data/Tests to be done

- Neutron radiation
- Increase dosage to 10 MGy
- Head-to-head comparison with Rayleigh/FBG
- Test strain/T coefficient vs. radiation

Radiation Resistant Fiber

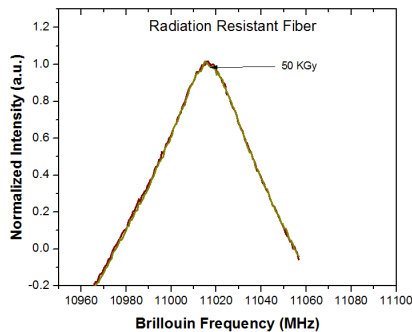

Radiation Sensitive Fiber

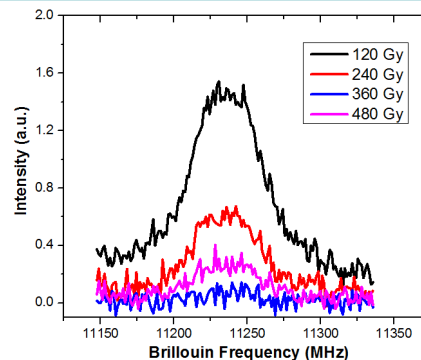



Spatial Mapping of Radiation

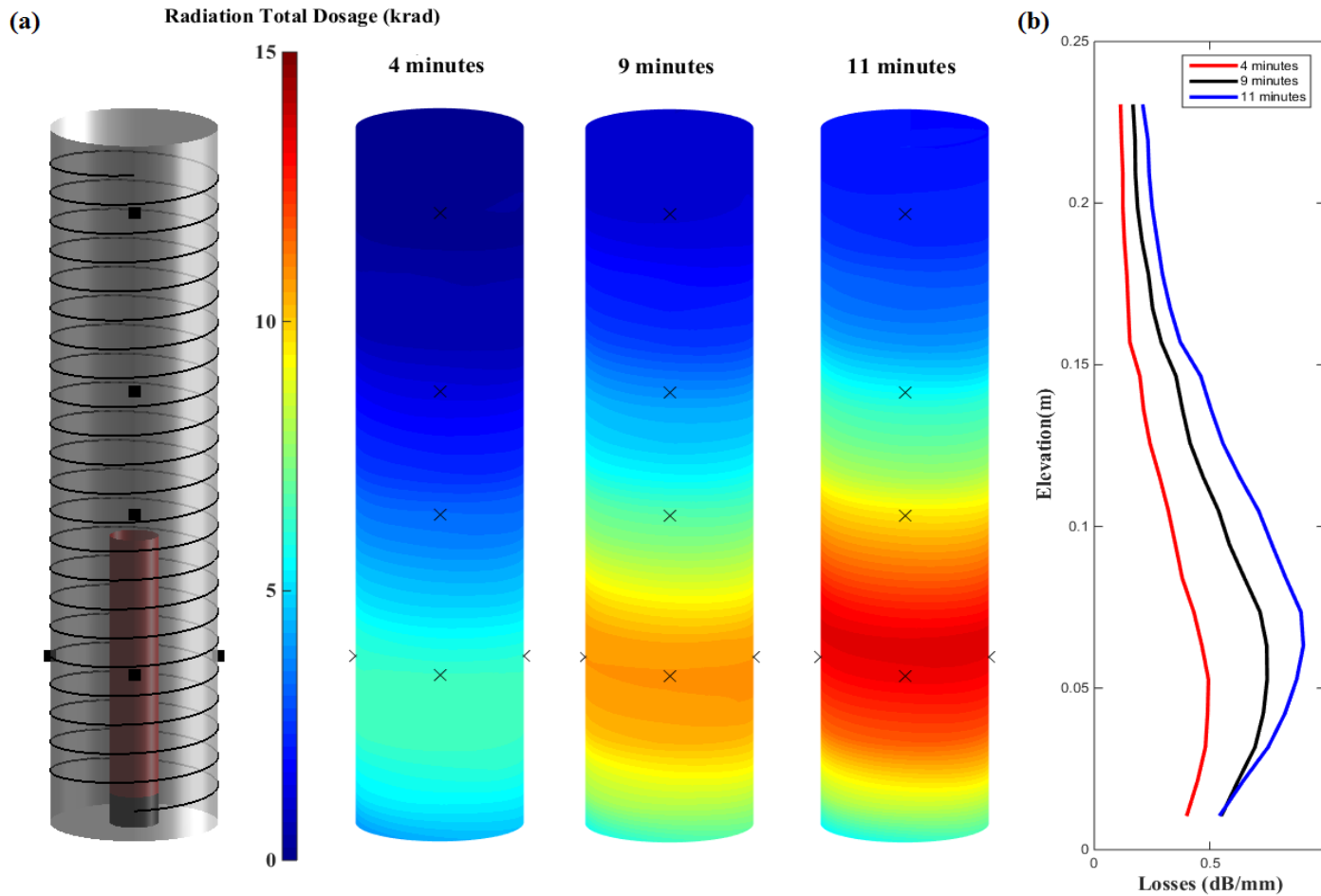



Electrical Cable as Sensor Platform



- Using electric cables as ubiquitous sensor platforms.
- No need to re-design nuclear power systems for sensor integration.
- **Direct monitoring of cable aging with high spatial resolution.**
- Fiber inserted as distributed sensors or point sensors with interrogation length 0.1-10 km.
 - Temperature
 - Pressure
 - Strain (cable degradation)
 - Volatile chemical and hydrogen
 - Leak and moisture
 - **Radiation**

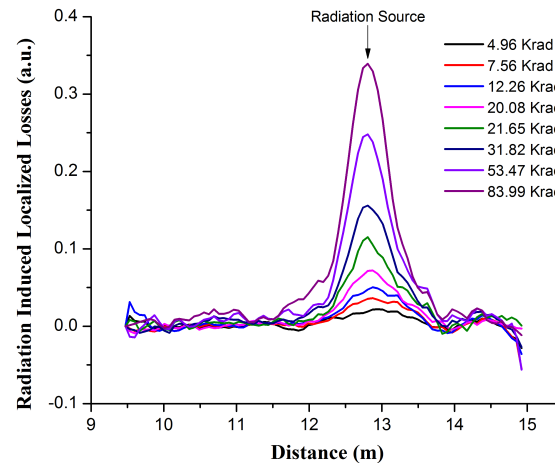
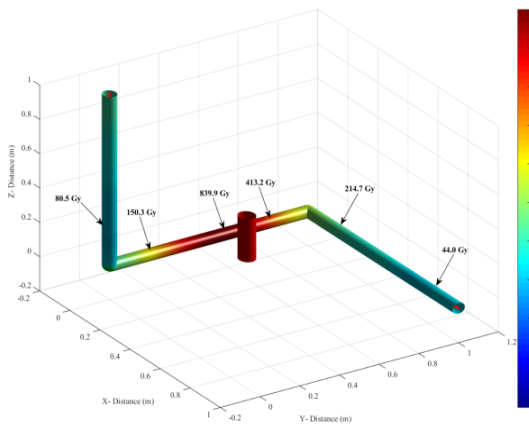



Distributed Pressure Measurements

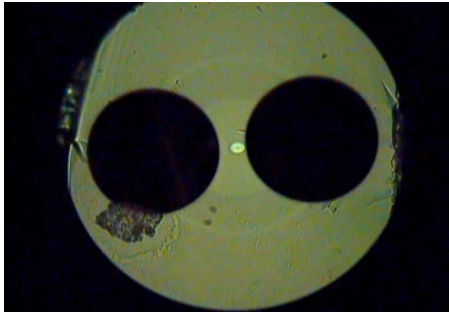

Large Diameter Elliptical-Core-Off-Centre Twin-Hole Fiber

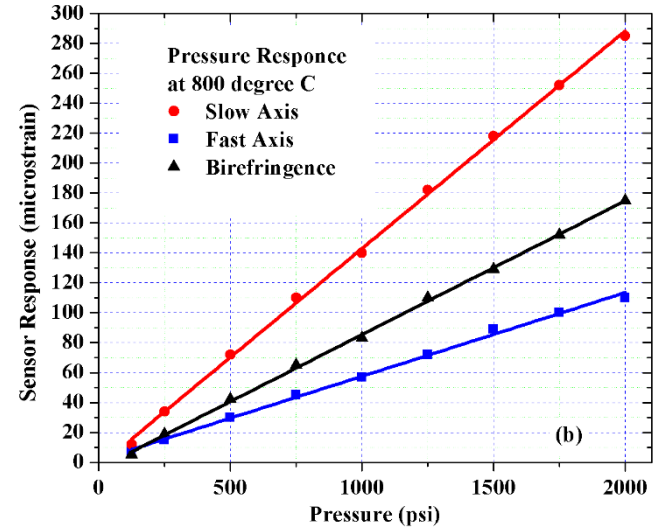
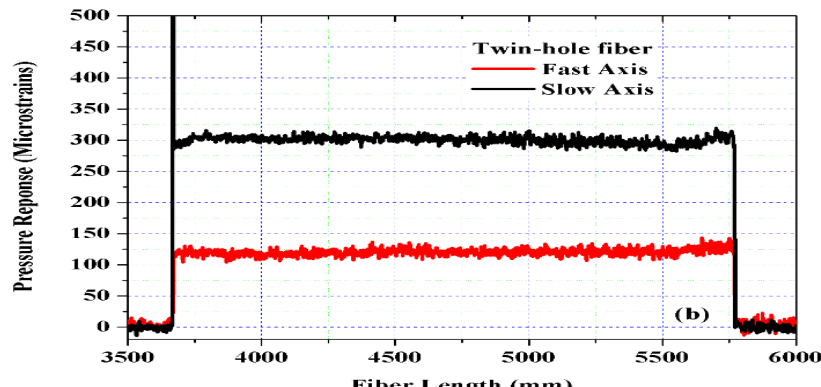
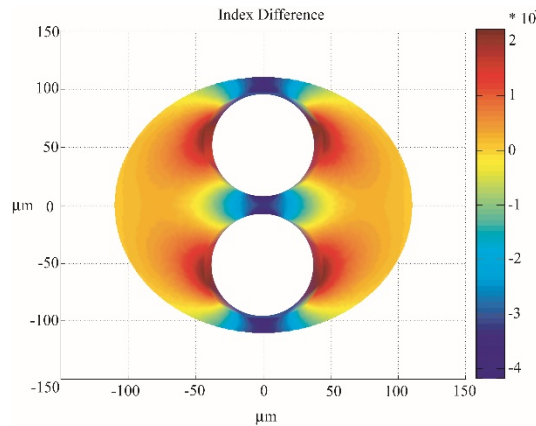

- OFDR birefringence measurements
- Rayleigh scattering reference between 2 polarization states
- Demonstrate distributed sensing cross 10-meters



Distributed Pressure Measurements for Steam Pipes

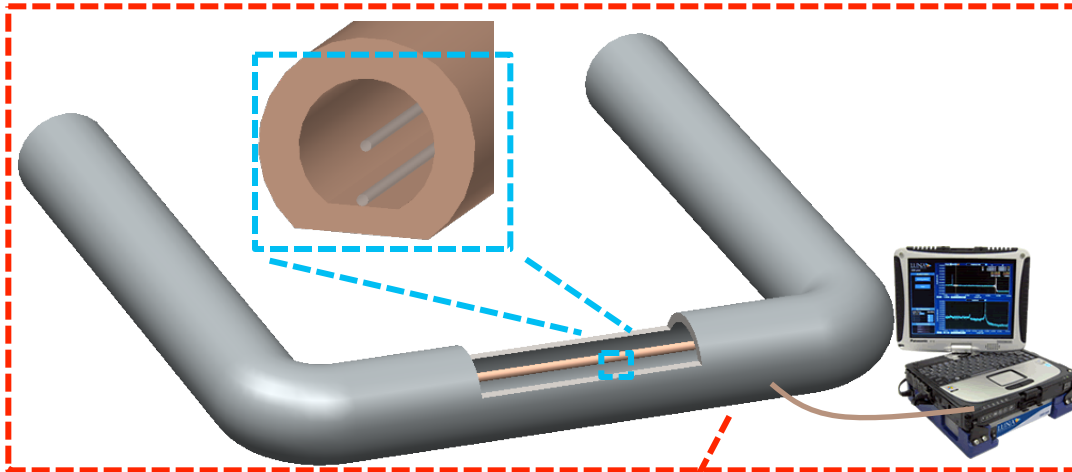

- “Appropriate” harsh environments (modest/minimal neutron radiation)
- Radiation-harden microstructural fiber for simultaneous temperature and pressure measurements
- T ~ 650C, Pressure 200bars
 - T resolution 1C
 - P resolution 1%
- Distributed fiber solution 1-cm resolution
- One fiber cable, one fiber feedthrough.

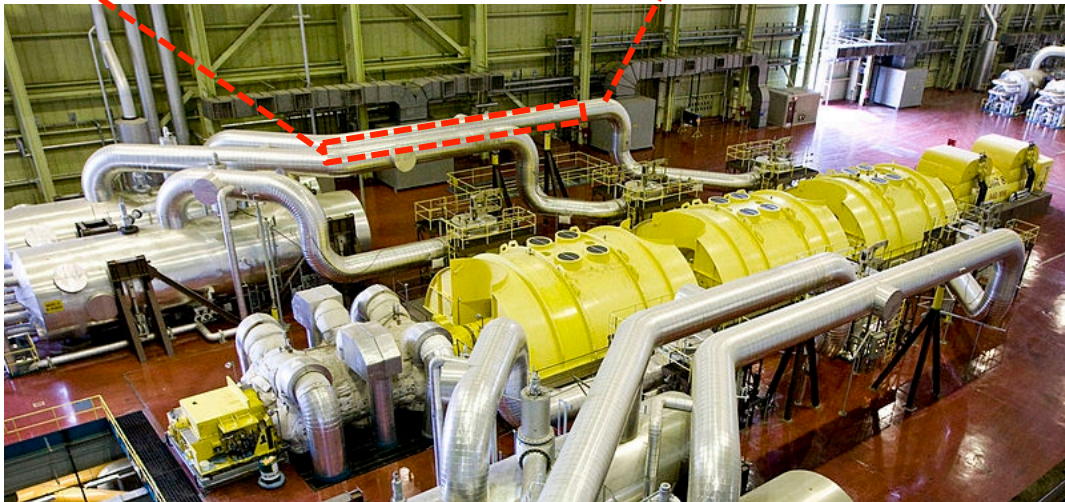



High-T Chemical Sensors

- **Nano-Engineered metal oxide sensory film**
 - Porosity control for refractive index matching
 - Rare-earth or noble metal dopants for specificity
 - Pd-TiO₂
- Sensor must operate >600C
- No electrical components in target environment

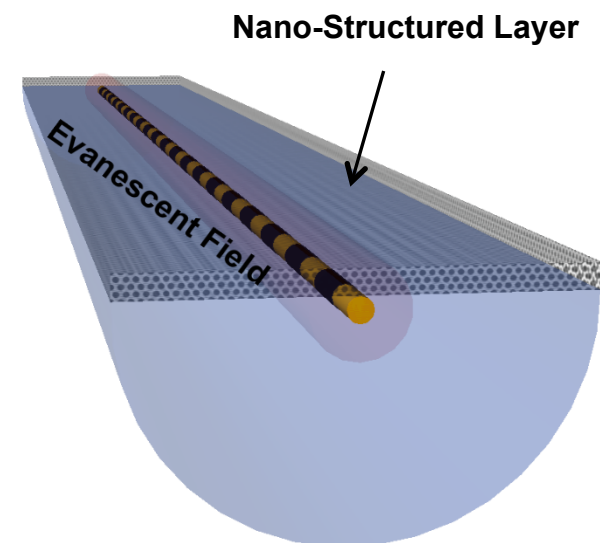
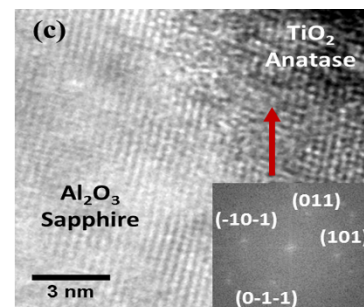
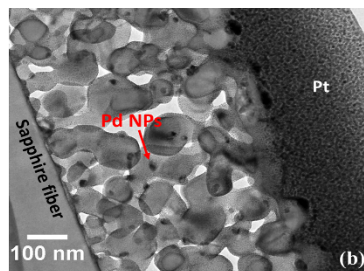
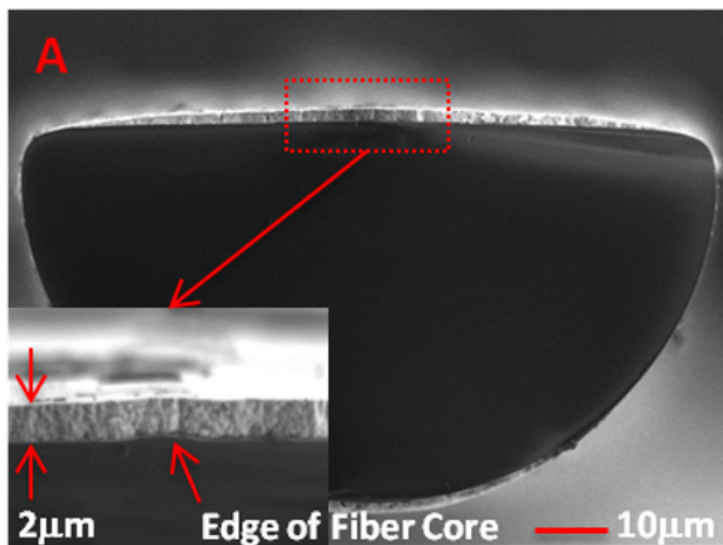



Fiber Optic Hydrogen Sensor at 700C

Optical Transmission vs. Hydrogen Concentrations

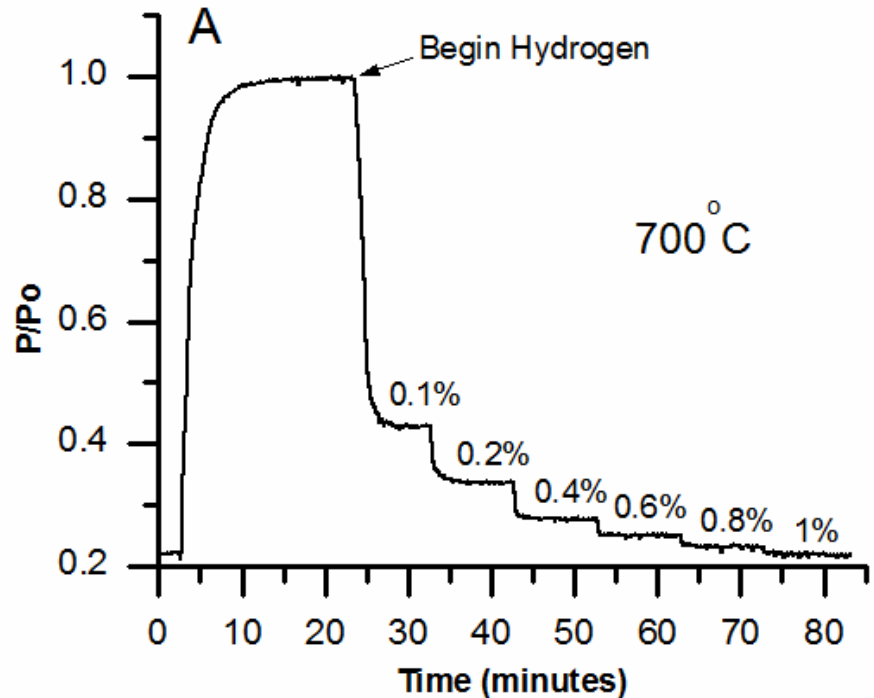
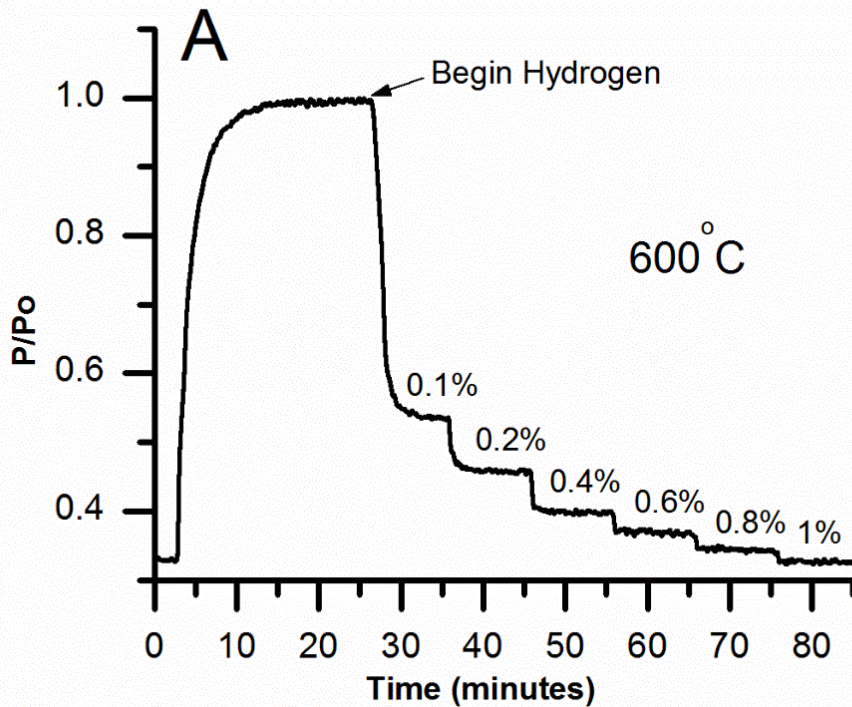

Exposed to various concentrations of hydrogen in nitrogen, recovered with nitrogen
Ideal for hydrogen driven energy conversion systems



Active Fiber Sensors: Level Measurements in Spent Fuel Rod Pool

All-temperature Continuous Level Sensing using self-heated fiber and Rayleigh backscattering:

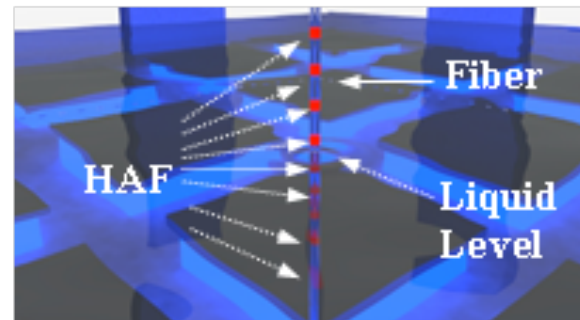
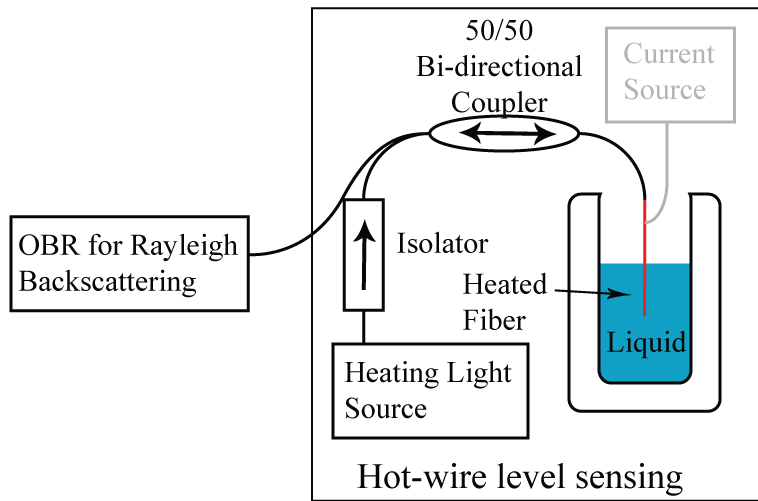
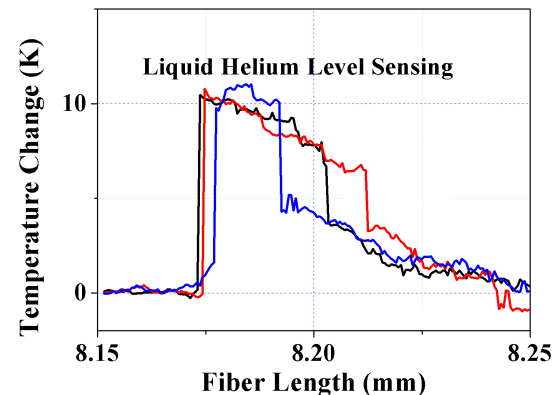
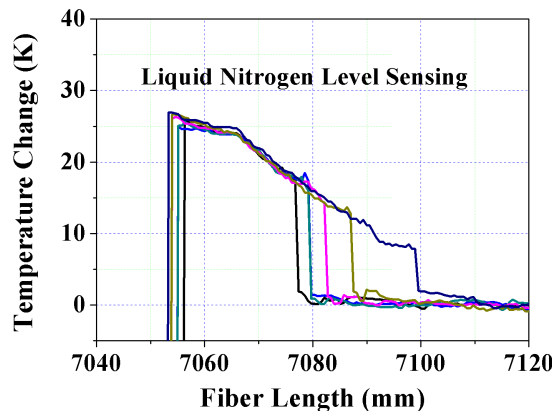

Fig. 10: schematic of active fiber level sensor in spent fuel rod pools.





Active Fiber Sensors: Level Measurements in Spent Fuel Rod Pool

- Heating span 10-m.
- Temperature fluctuation might caused by air flow or coating
- 1-10W electricity for heating
- Power off: temperature measurements
- Power on: water level measurement.
- High sensitivity to surrounding medium validated

Uniform Heating Cross 10-m Span

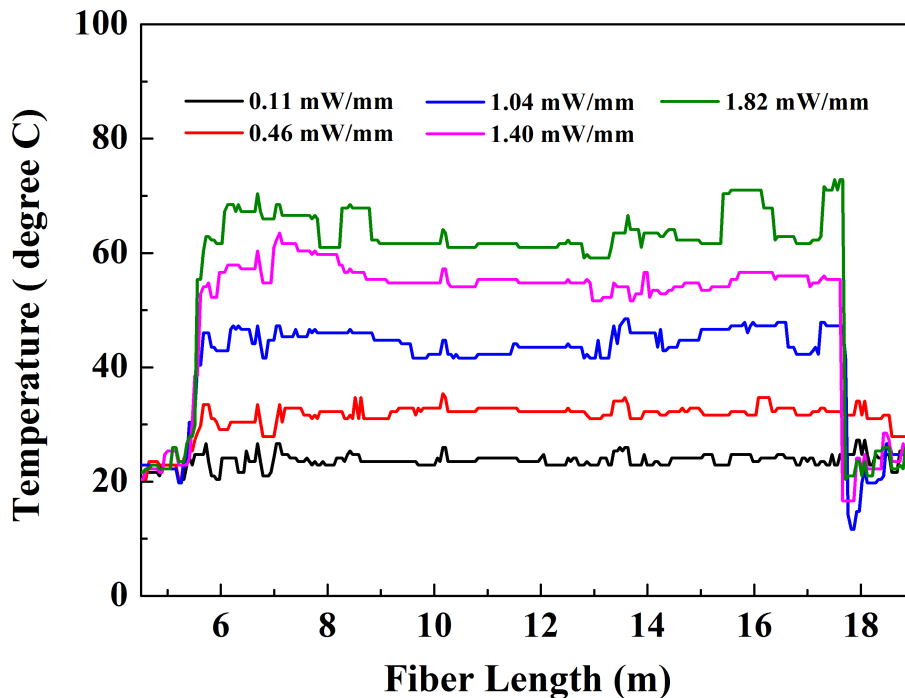

Brillouin Frequency vs. T

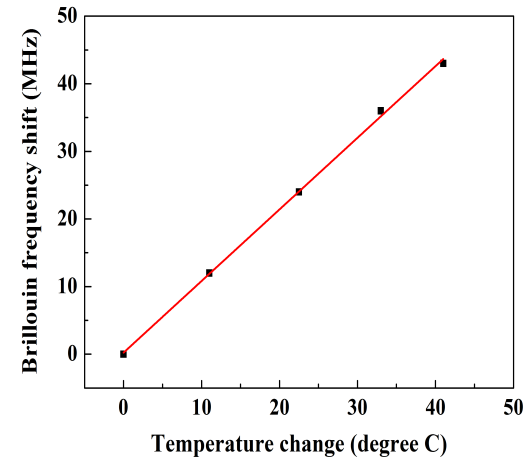

Level Sensing in Waters

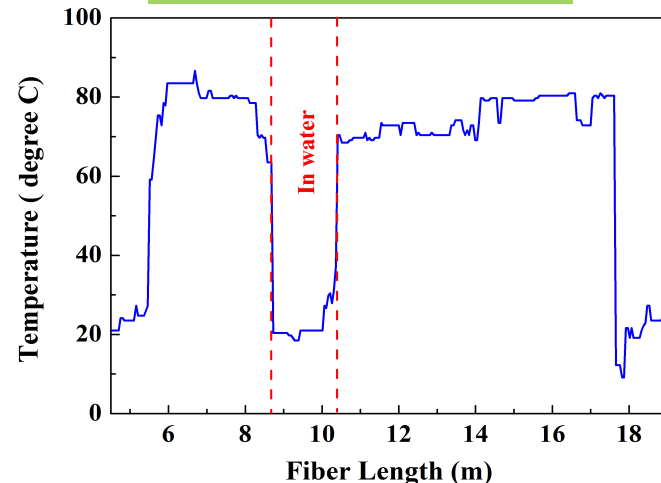



Sensor-Fused Additive Manufacturing

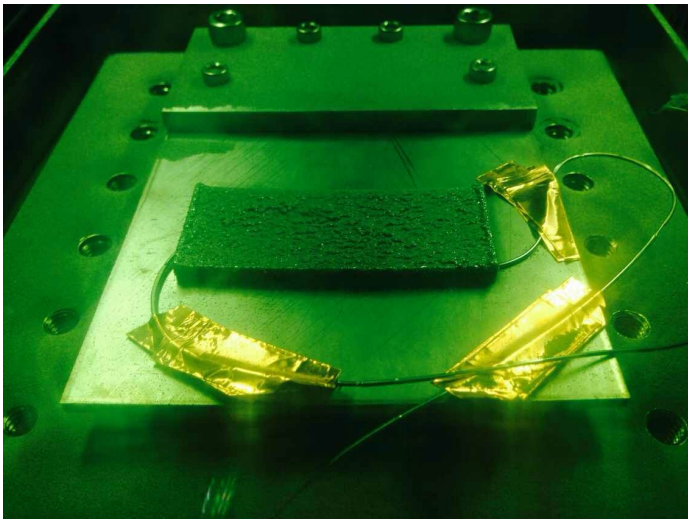
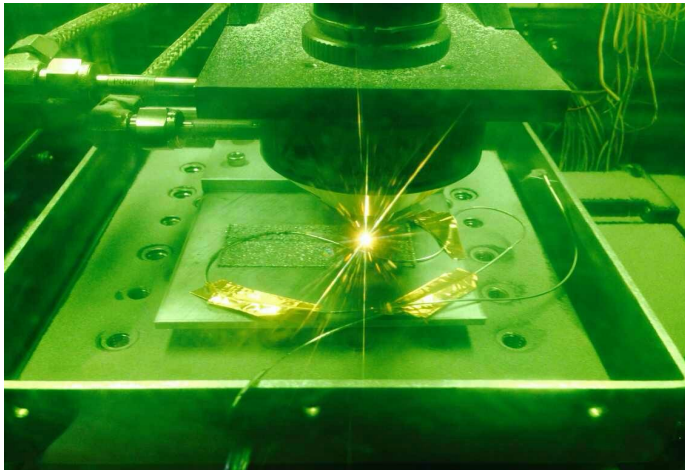

■ Establish a reliable way to implement fibers in harsh environments

- Standard optical fibers
- Electroless/sputtering coating of glue layers
- Electroplating of Ni/Fe protective layer
- Embedding process using a 3D printing scheme (LENS) into mixed alloy
- Repeated thermal cycling and annealing at 900C appears to yield consistent results
- 3D printing provide GREAT protection to fiber sensors

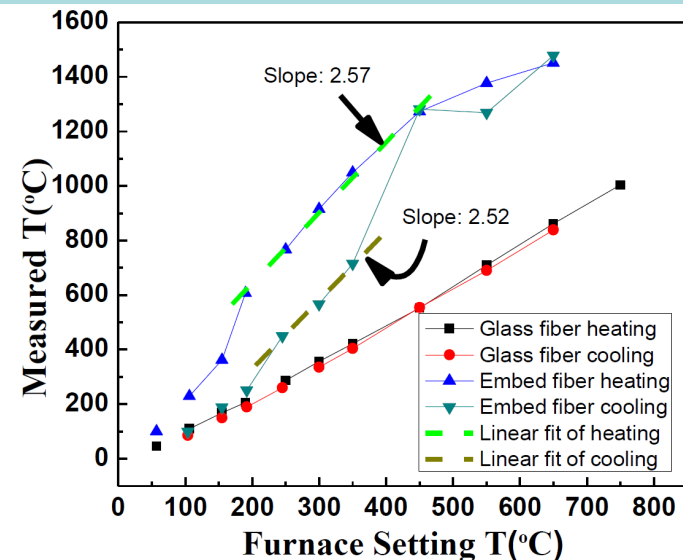



TEC of Fe-Ni Alloy

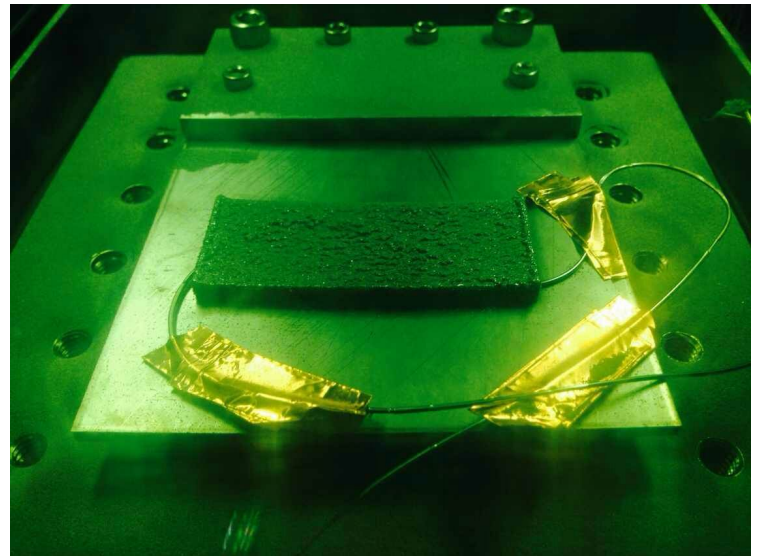
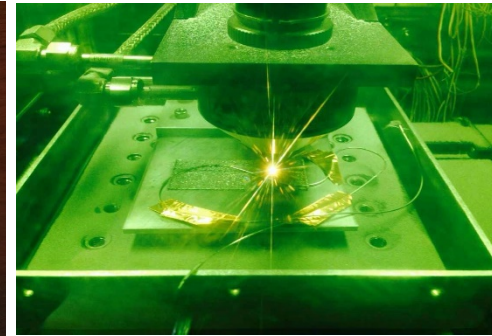
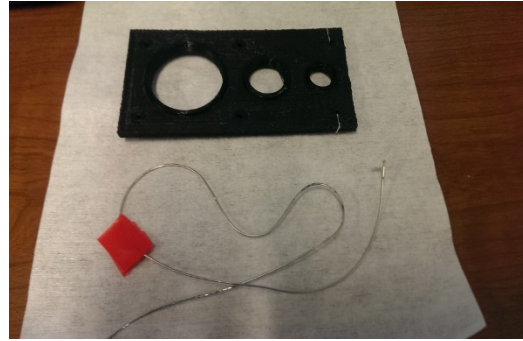
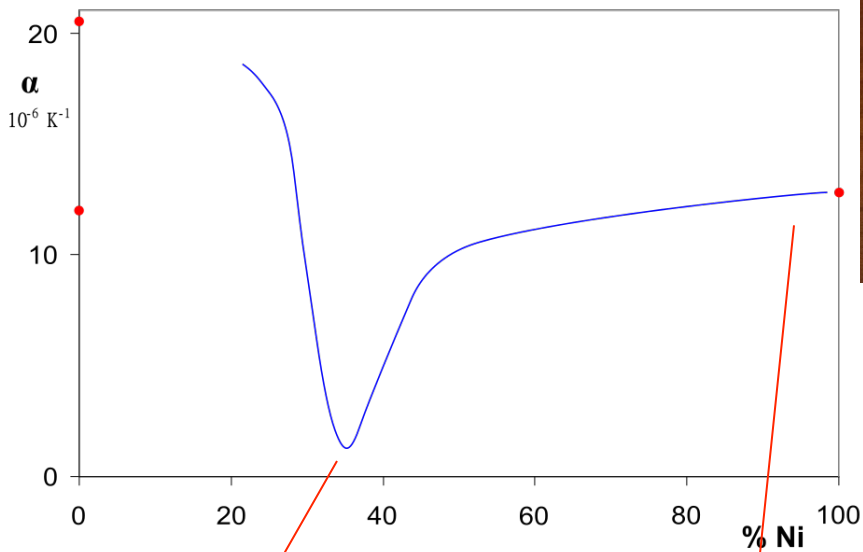

Volume: First principal strain (1)

Volume: First principal strain (1)

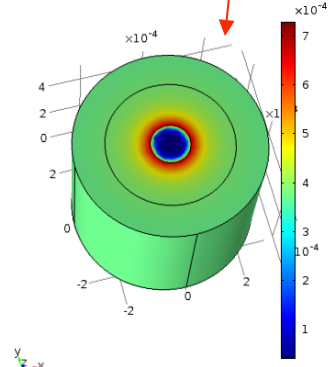
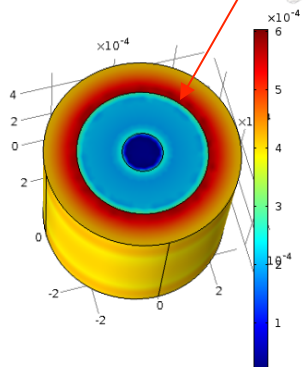



Fiber Optic Acoustics Sensor for Fast Sodium Reactor

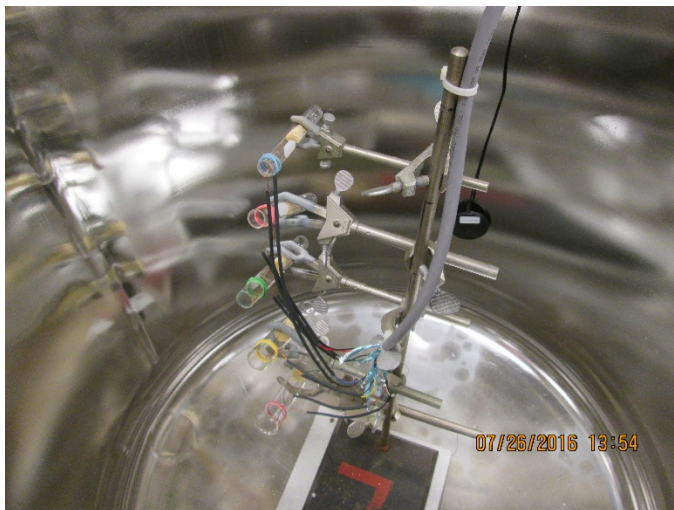

- Thermal acoustic resonators for in-pile temperature sensing.
- Simulators have five acoustic resonators
- Distributed feedback fiber lasers as acoustic sensors
- 3x3 interferometer for fast signal decoding
- Cut-off frequency of measurements 150 kHz
- Frequency measurement accuracy at 1 Hz



Nuclear Energy

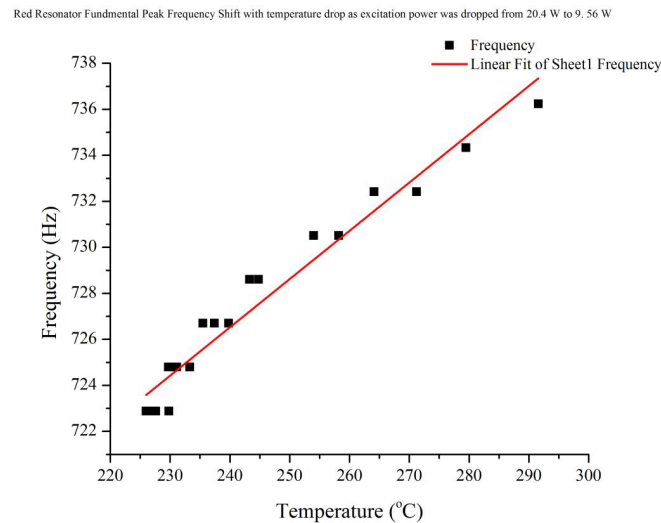
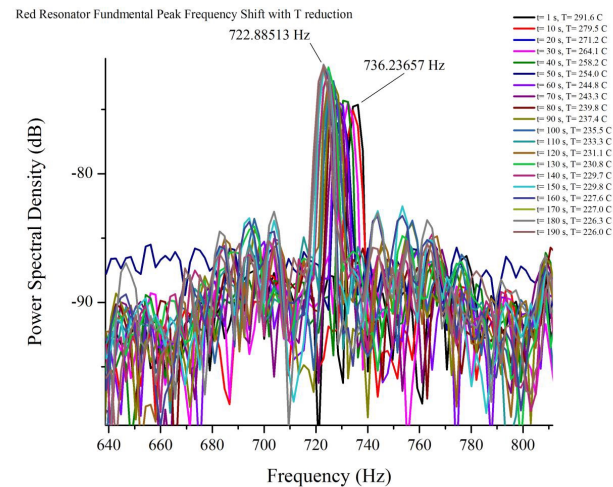
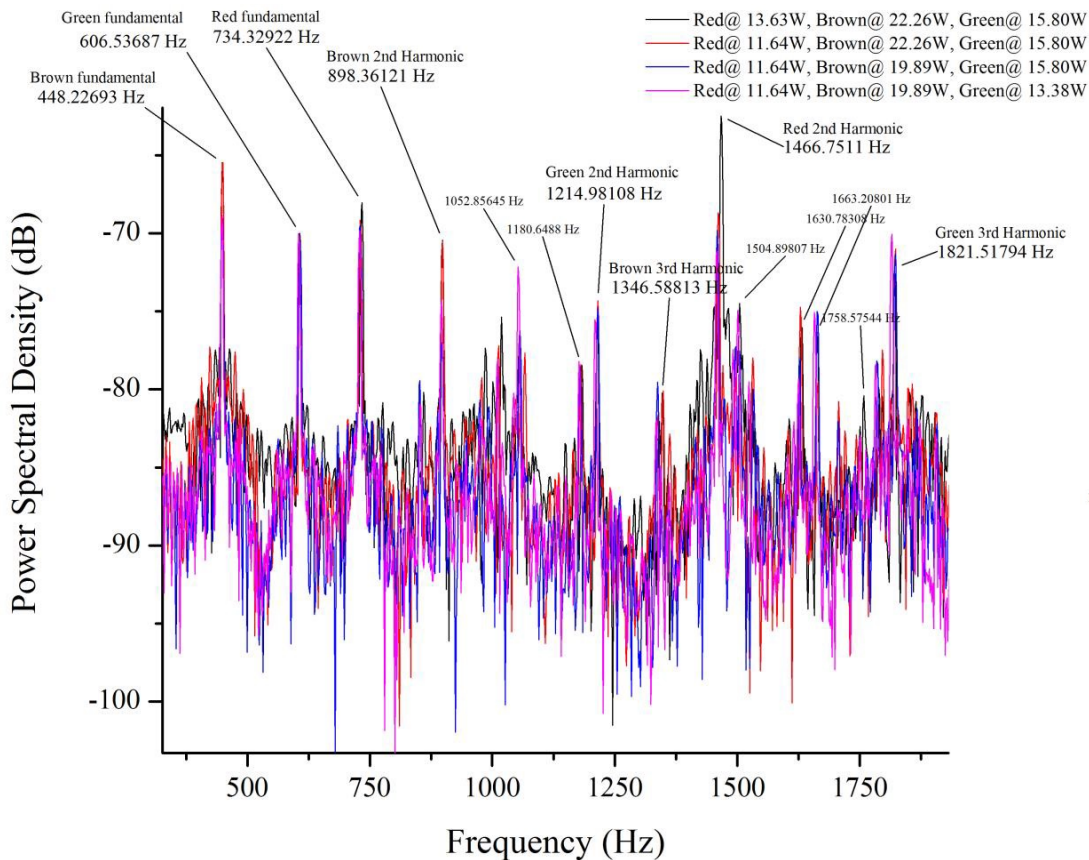

FBG Point Sensors and Distributed Sensors

Thermal Regeneration Process

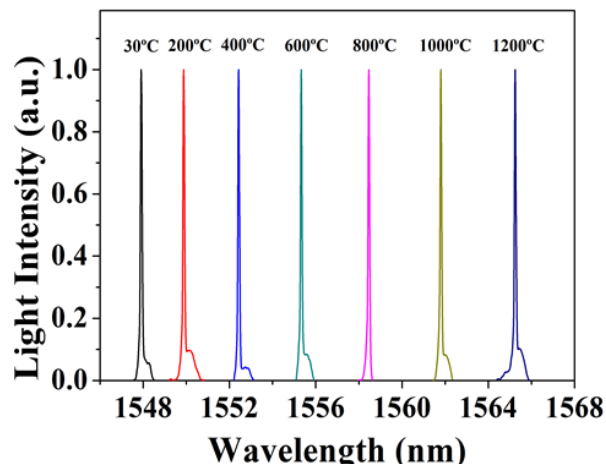
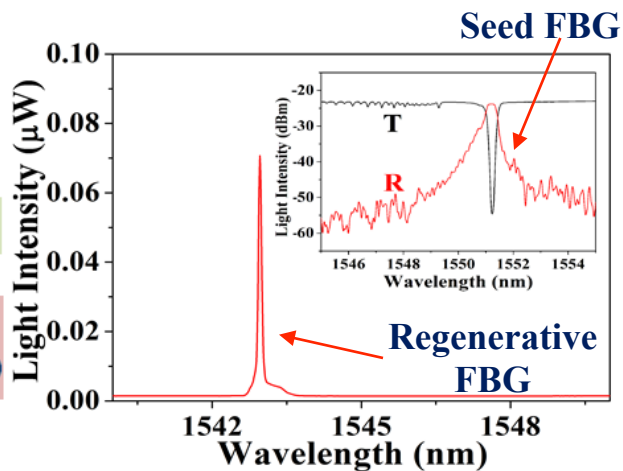
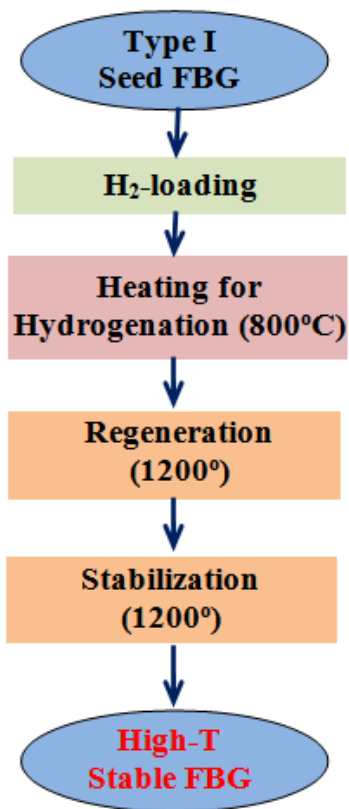

Enhanced Rayleigh Scattering

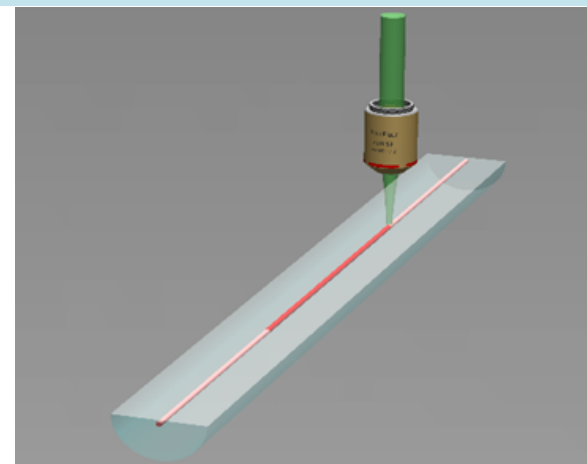

Ultrafast laser irradiation

- Ti:Sapphire 250-kHz, 180-fs, 780-nm
- 0.2-0.5 μJ , 0.5-10 mm/s

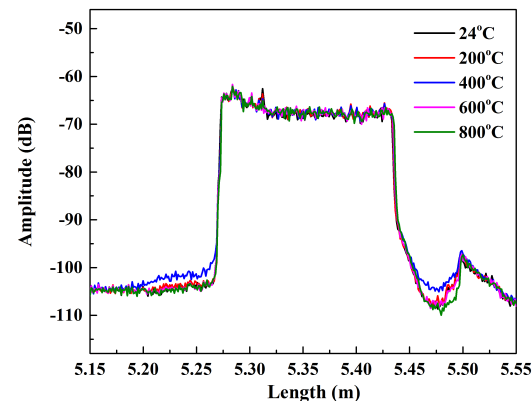



Highly Stable Rayleigh Fibers at High-T

- Rayleigh enhanced fiber stable up to 800C in 10% hydrogen!
- Temperature measurement 5-mm spatial resolution
- Repeatability better than 4C at 800C in H2 environments

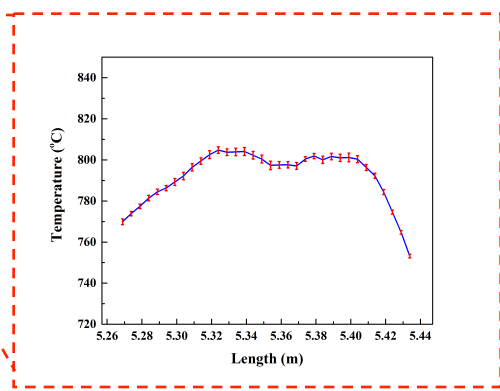
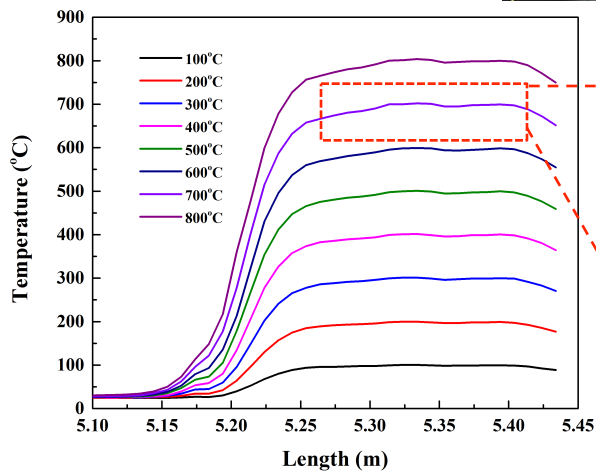
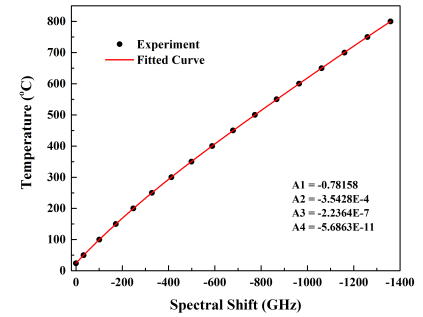
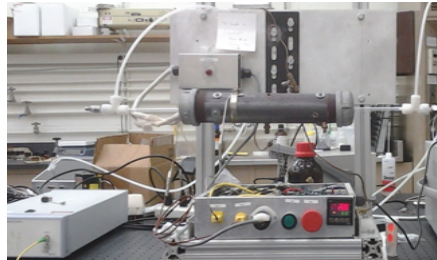
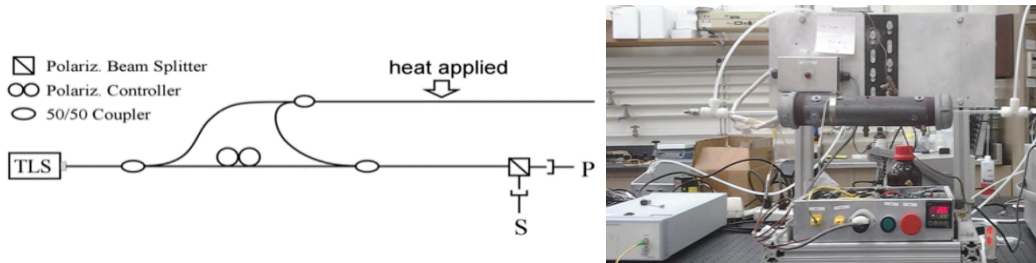



Technology Impacts and Conclusion

- **Advances the state of the art and support NE and nuclear industry**
 - *Develop distributed fiber sensing solutions to perform robust and multi-functional measurements beyond T and $\mu\epsilon$.*
 - *Develop new optical fibers with an integrated function for distributed radiation measurements.*
 - *Provide unique sensing capability unattainable by other measurement schemes*
- **Explain how this technology impacts nuclear stakeholders**
 - *Improve safety of nuclear power systems: distributed fiber chemical sensors for gas measurements (e.g. Hydrogen), distributed fiber sensors to monitor spent nuclear fuel pools, and etc.*
 - *Provide new tools to monitor radiation effects to critical components, systems, and infrastructures.*
 - *Mature TRL levels of fiber sensors by developing new sensor packaging scheme and sensor-fused smart components*

Questions?

Kevin P. Chen
University of Pittsburgh
Email: pec9@pitt.edu
Tel. 412-624-9675