

Summary of ANL's FY-16 Environmentally Assisted Fatigue Work in Support of LWRS Program

Major Highlights:

- Variable Amplitude Fatigue Test & Material Modeling.
- 3D FE Modeling of PWR Reactor Pressure Vessel and Nozzle under Grid Load-Following.

Subh Mohanty, Bipul Barua, William Soppet, Saurin Majumdar, and Ken Natesan

Nuclear Engineering Division, Argonne National Laboratory

Presented by Subh Mohanty

16th August 2016

OUTLINE

- ❑ Background Information
- ❑ Cyclic-Plasticity Introduction
- ❑ Experiment: Variable Amplitude Fatigue Test
- ❑ Material Modeling Based on Variable Amplitude Fatigue Test Data
- ❑ Cyclic-Plasticity 1-D Analytical Modeling
- ❑ 3D-FE Isothermal Stress Analysis of Fatigue Test Specimen
- ❑ 3D-FE Thermal Analysis of RPV & Nozzles under Grid Load-Following
- ❑ 3D-FE Thermal-Mechanical Stress Analysis of RPV & Nozzles under Grid Load-Following
- ❑ Experiment: Grid Load-Following (Random Load) Fatigue test
- ❑ Summary & Future Plan

Background Information

Background Information:

ANL is trying to develop an experiment-mechanistic framework for stress analysis & life estimation of reactor components under thermal-mechanical cycles and reactor environment.

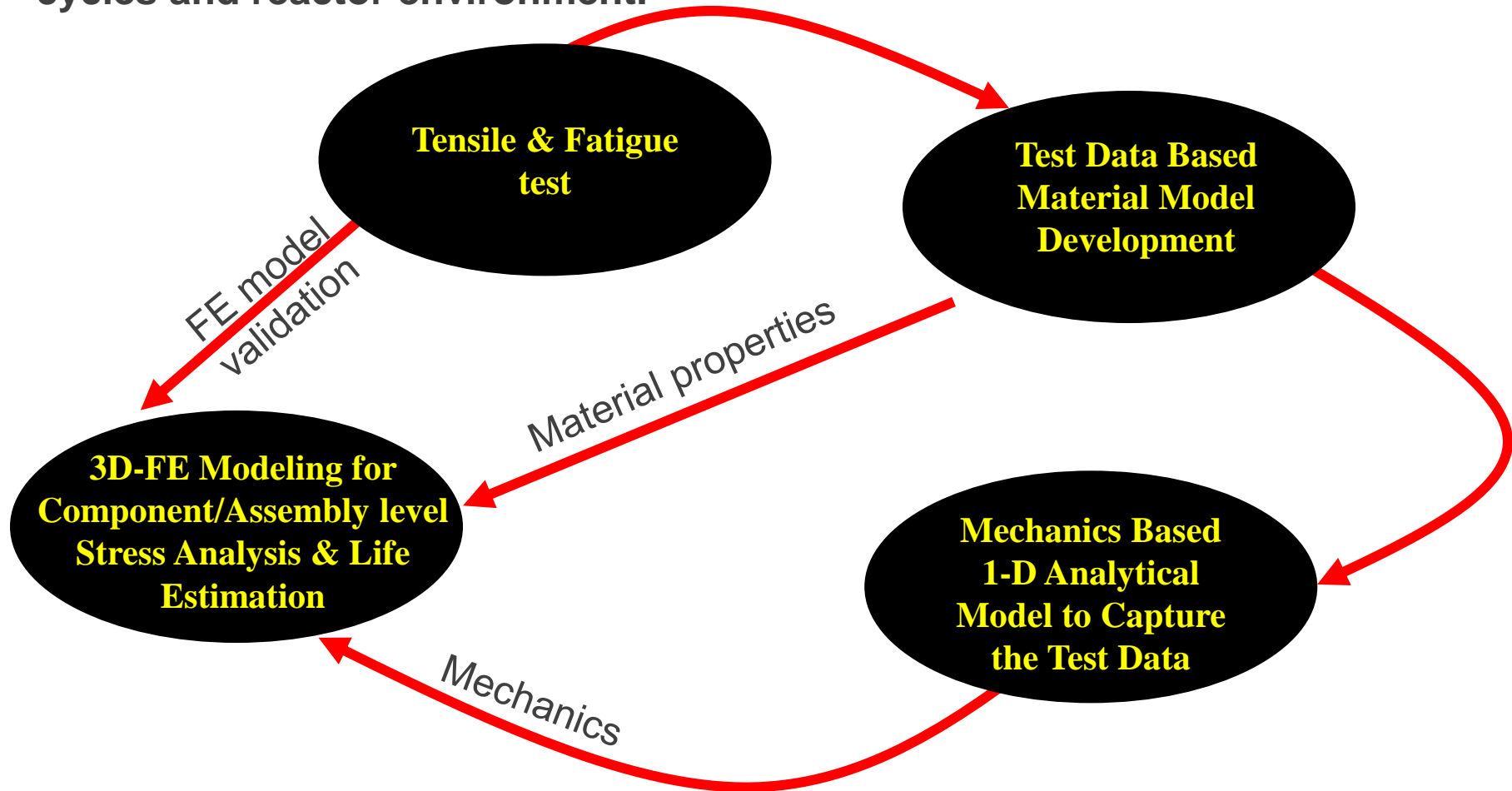

Cyclic-Plasticity Introduction

Why Cyclic-Plasticity ?

Current Industry Approach:

→ Life estimation based on end of test stress-life (S~N) curve and in general on elastic stress analysis results.

Generic & Intended Structural Feature of Reactor Components:

→ In general reactor components are bulky and overdesigned (context of strength)

→ Stress-strain state in reactor component stays well below the yield stress.

→ When stress-strain state below yield limit ➤ No fatigue or the NPP component has ideally infinite life.

Why Reactor Component (if only considered SCC) Still Fails ?

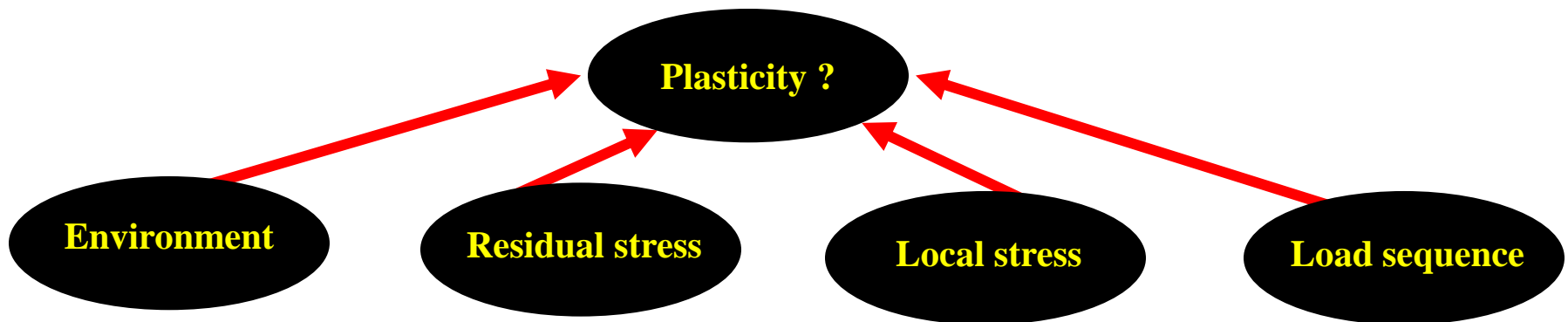

Introduction to ANL's Cyclic Plasticity Model

Yield Function:

Conventional Elastic-plastic FE model: **FIXED** back stress & Yield stress parameters

$$f(\sigma_i^j - \alpha_i^j) = \sigma_i^y$$

ANL's Elastic-plastic FE modeling approach: **TIME VARYING** back stress & Yield stress parameters

ANL proposed time-dependent variable Yield and Chaboche model

$$d\alpha_i^j = \frac{2}{3} C1_i^{av}(p) d\varepsilon^{pl} - \gamma1_i^{av}(p) \alpha_i^j \bar{p}$$

Example offset strain (0.05%) yield limit stress for 316 SS-316 SS weld specimens fatigue tested under different conditions
 (Ref. Mohanty, et al. Nuclear Engineering and Design 305 (2016): 524-530)

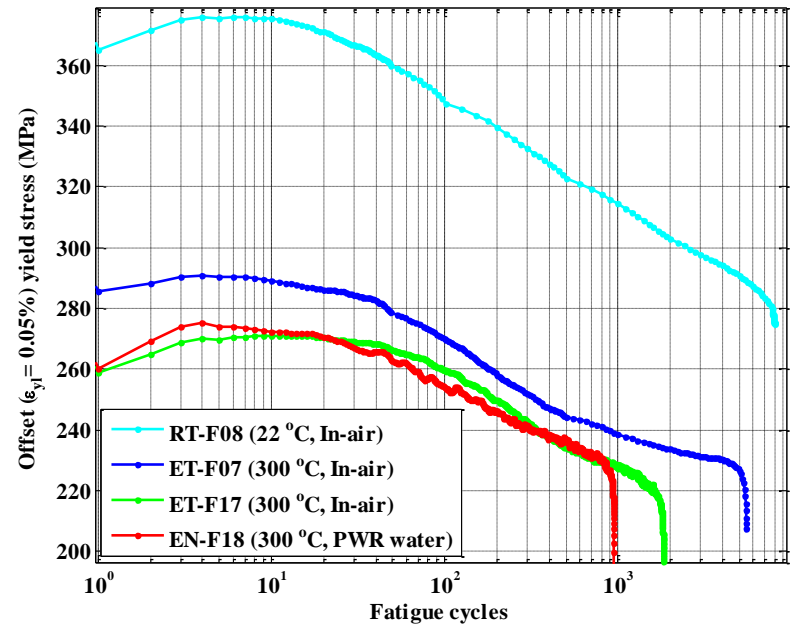

Experiment: Variable Amplitude Fatigue Test

ANL's Experiment Strategy

Objective:

→ Perform tensile & fatigue test of Key RCS material (Five different materials) under in-air & PWR water conditions.

→ Perform constant, variable and random (e.g. grid load-following cond.) amplitude fatigue tests

Environmental test frame with PWR water loop and autoclave

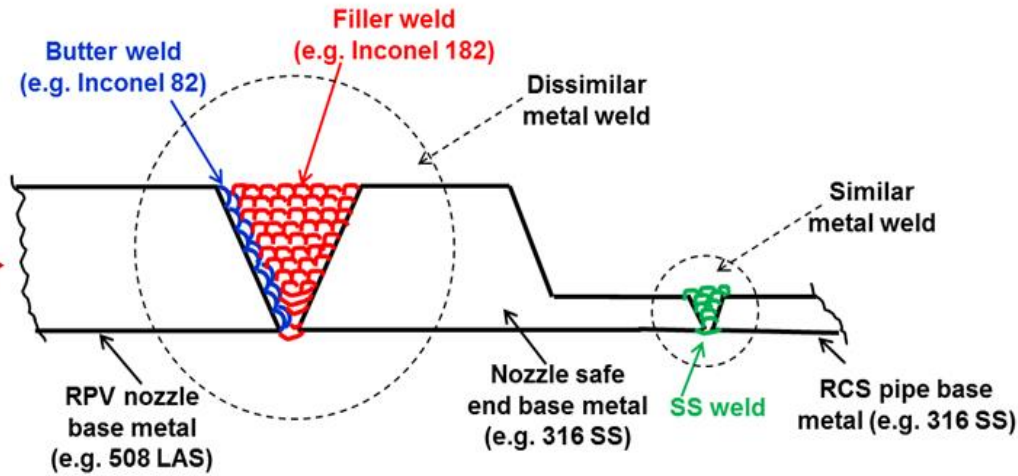
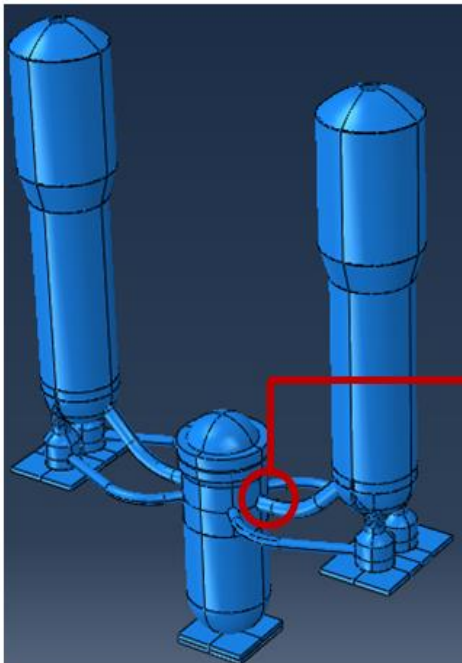
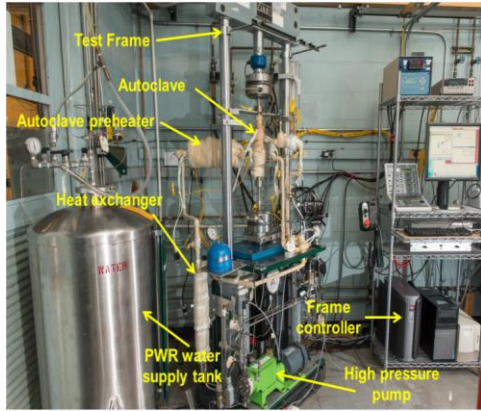

Variable amplitude fatigue test

Why it is needed ?

- Constant amplitude fatigue test can be used for estimating time dependent material properties (e.g. yield stress, etc.)
- However, it may not capture the effect of loading amplitude and hence load sequencing effect under random loading (e.g. grid load-following) conditions.

What we need from variable amplitude fatigue test data?

Material properties (for FE model) =
 $f(\text{Environment, Time/Aging, Loading Amplitude, etc.})$

Variable amplitude fatigue test results

➔ Variable amplitude (stress control) fatigue test conducted under in-air and PWR water condition and at 300 °C.

Example 1st three block applied stress amplitude

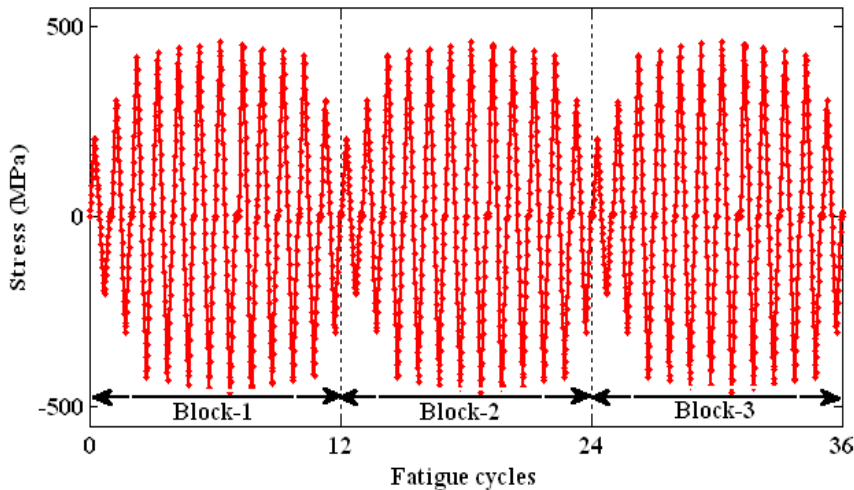

In-air cond. cyclic & equivalent monotonic stress-strain curves for block-1

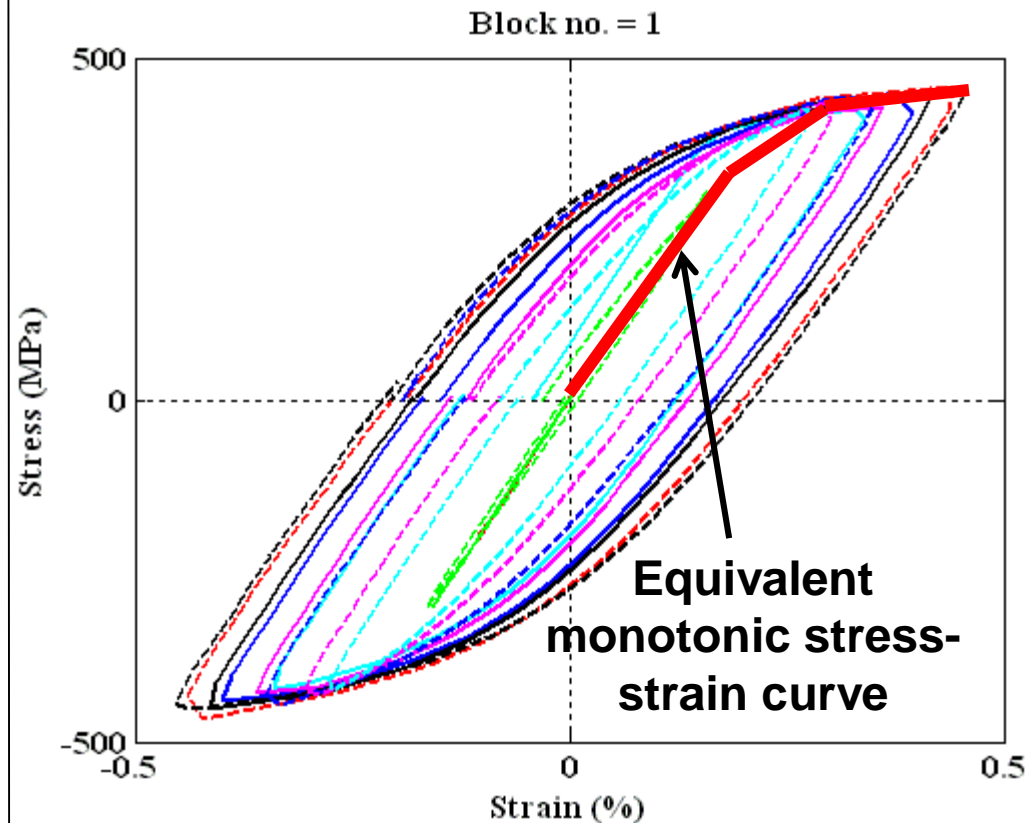

Material Modeling Results

Example parameters estimated based on 300 °C, in-air variable amplitude fatigue test data

➔ Estimated using each block equivalent-monotonic stress-strain curve to capture the effect of time and amplitude.

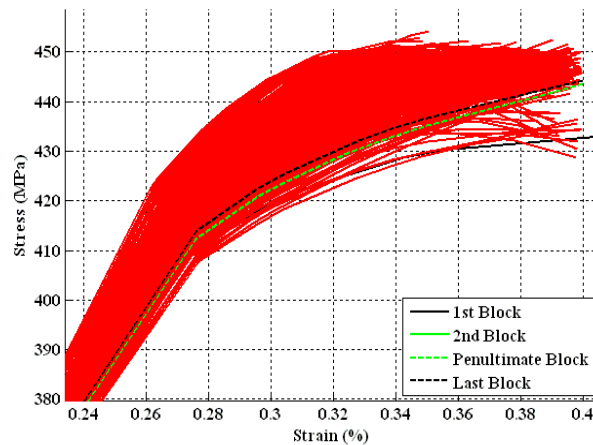
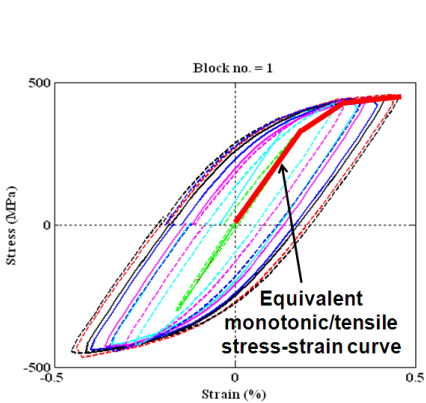

Example property

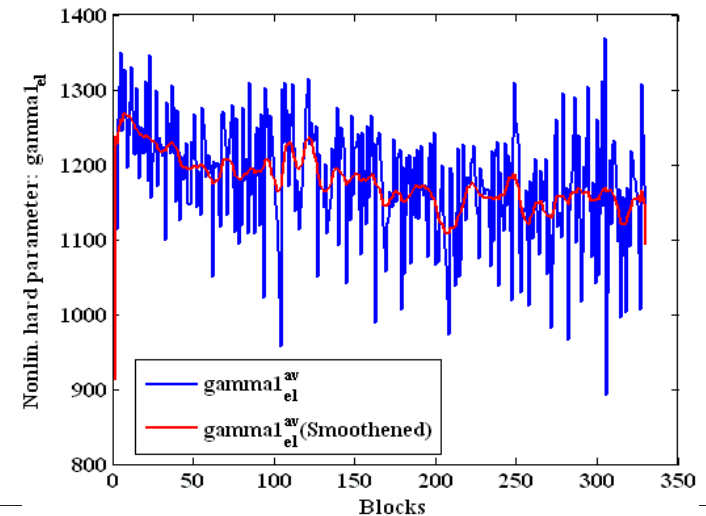
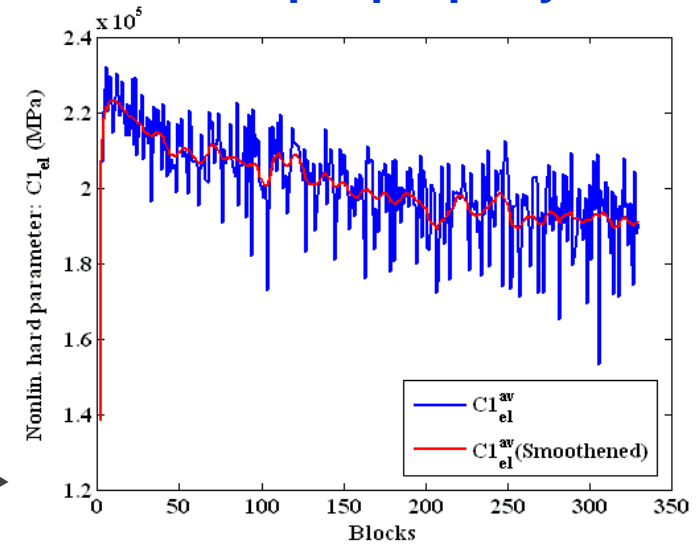

Cyclic-Plasticity Analytical Modeling Results

Example analytical modeling results (Constant amplitude case: Effect of time dependency on material properties)

→ 1-D analytical models are to understand the mechanics and to check the accuracy of estimated parameters.

→ In-air (300 °C) 508 LAS specimen (constant amplitude, stress controlled) test case modeled.

Experiment versus predicted hysteresis curve (for first 20 cycles and using tensile test based fixed parameters)

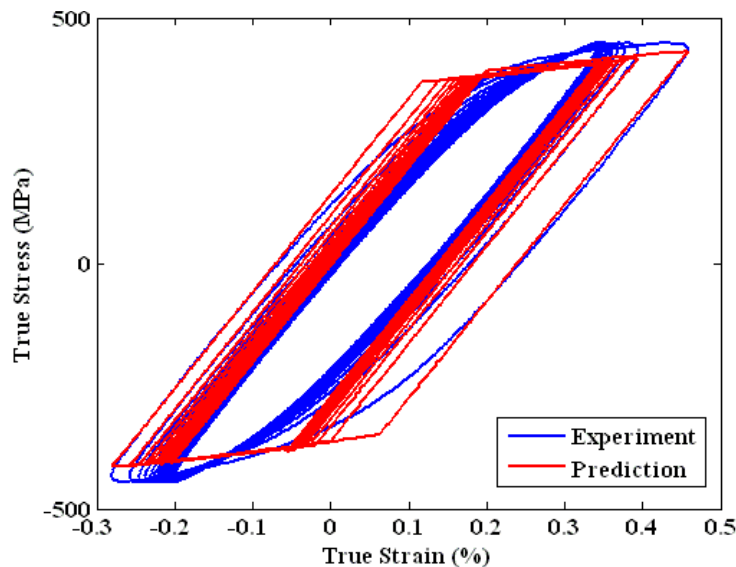

Experiment versus predicted hysteresis curve (for first 20 cycles and using fatigue test based variable-time-dependent parameters)

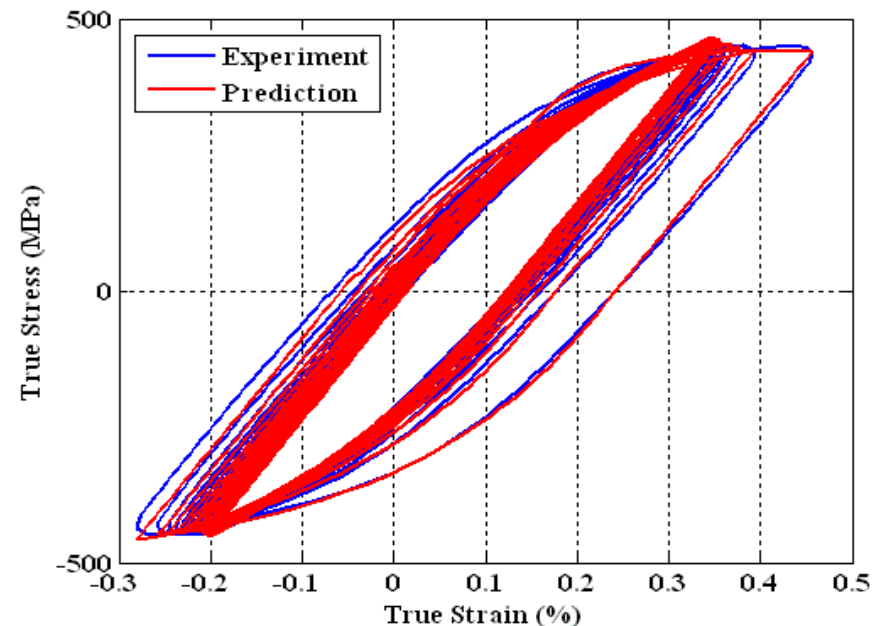

Example analytical modeling results (Variable amplitude case: Effect of time & amplitude dependency on material properties)

→ In-air (300 °C) 508 LAS specimen (variable-amplitude, stress-controlled) test case modeled.

Block-1 prediction based on tensile test based parameter

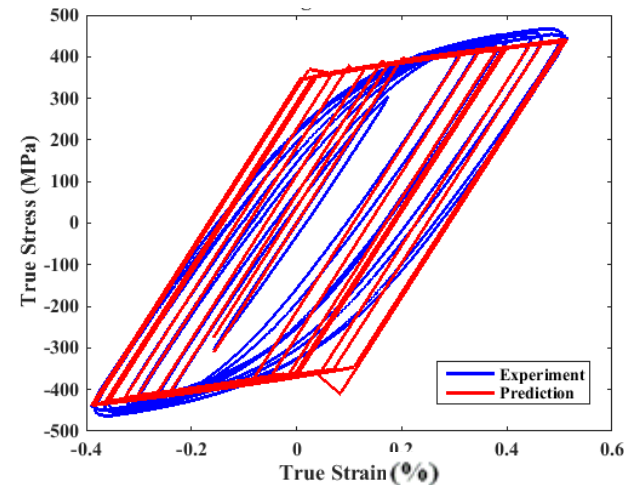

Block-1 prediction based on 1st quarter cycle (constant amplitude fatigue test) based parameter

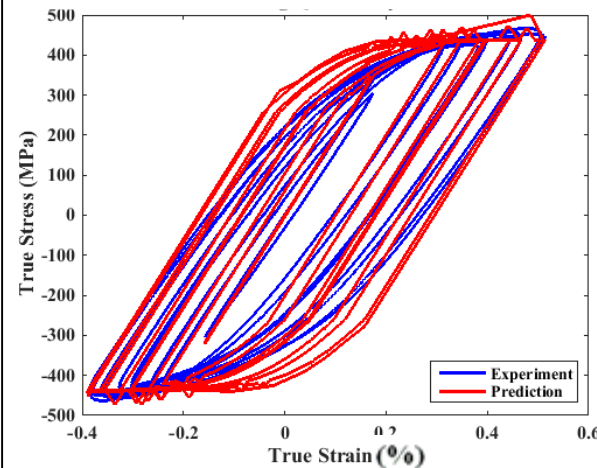

Block-1 prediction based on (variable amplitude fatigue test) 1st block based block-averaged parameters

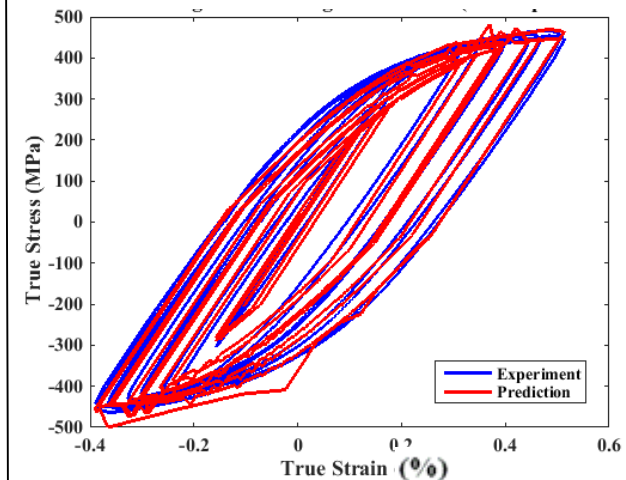

This preliminary result shows the importance of variable amplitude test based parameters

3D-FE Isothermal Stress Analysis of Fatigue Test Specimen

3D-FE model results: PWR water fatigue test specimen

FE model

- Earlier estimated 508 LAS (constant amplitude fatigue test) material properties used.
- The intention was to check the performance of estimated material parameters with respect to 3D elastic-plastic FE model.

Example time-varying 508 LAS material properties for different cond.

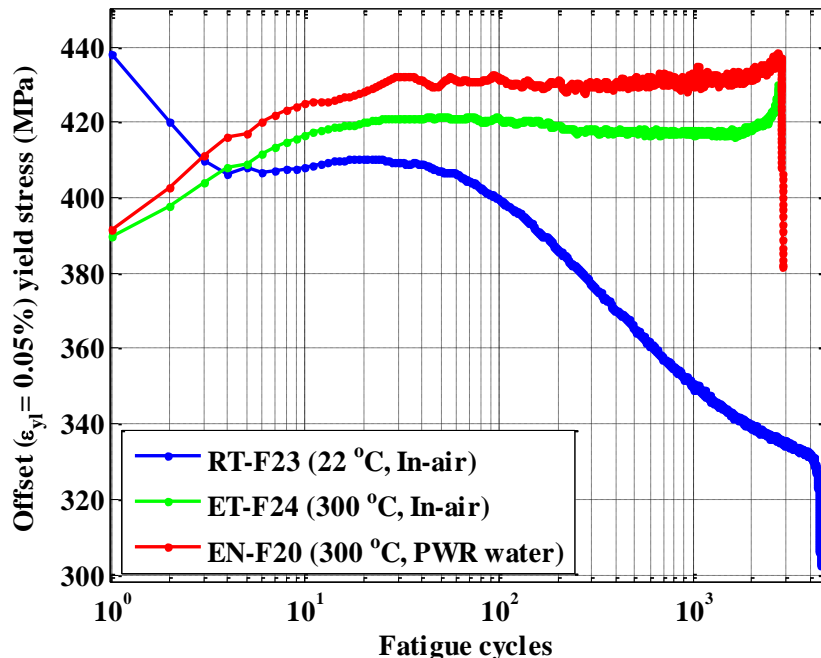

Example applied crosshead displacement (stroke) for EN-F20 PWR water test

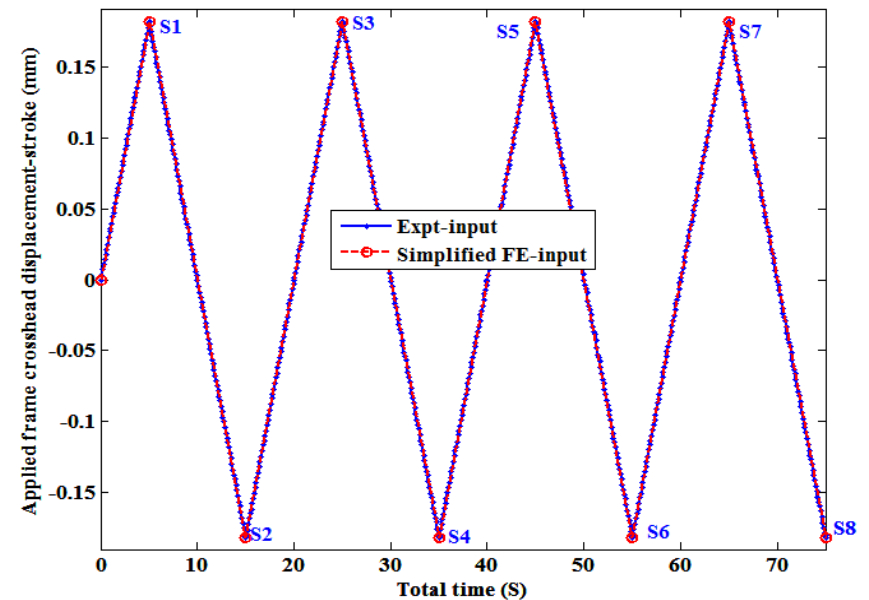

3D-FE model results: PWR water fatigue test specimen (cont.)

Predicted vs experiment strain

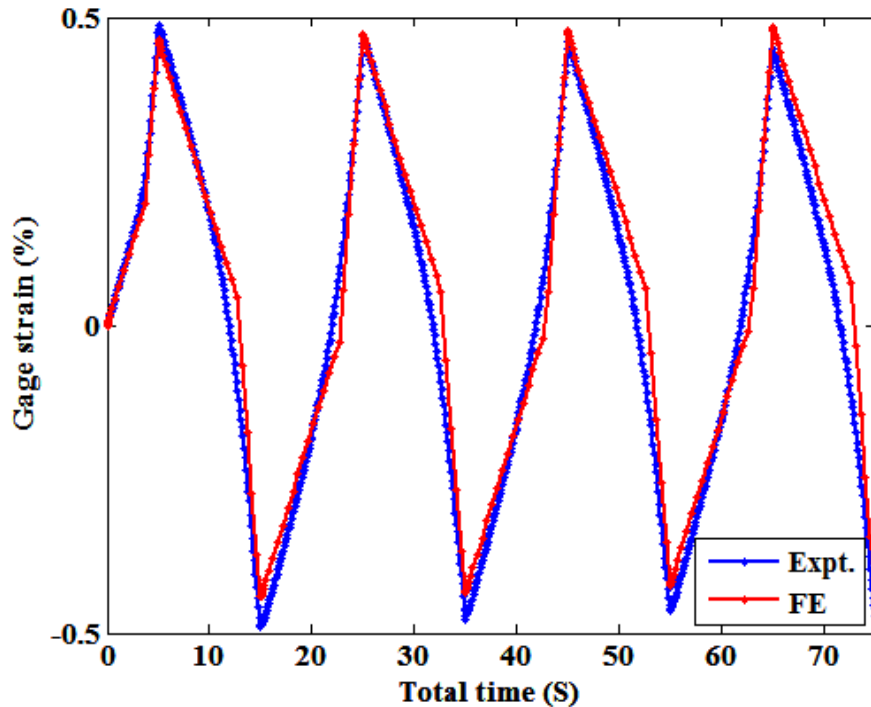

Predicted vs experiment stress

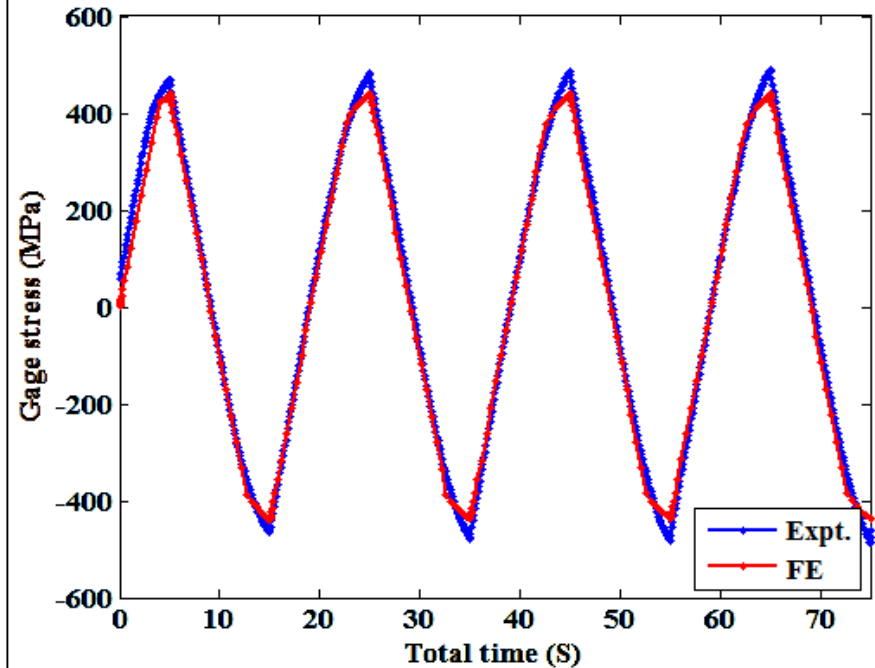

This preliminary result shows that the estimated material parameters can reasonably be used for the 3D-component level FE models

3D-FE Thermal Analysis of RPV and Nozzles under Grid Load-following

FE modeling of reactor components under grid-load following (For single fuel cycle)

Why simulation under grid following load ?

→ Increasing penetration of renewable sources to interconnected power grid may overstress the NPP components due to fluctuations in power demand.

→ Power fluctuations can create load sequence effect on reactor material which may accelerate or deaccelerate the reactor metal degradation under thermal-mechanical-water environment.

Example power fluctuation under grid-load following for single fuel cycle (Source data: NEA & EDF)

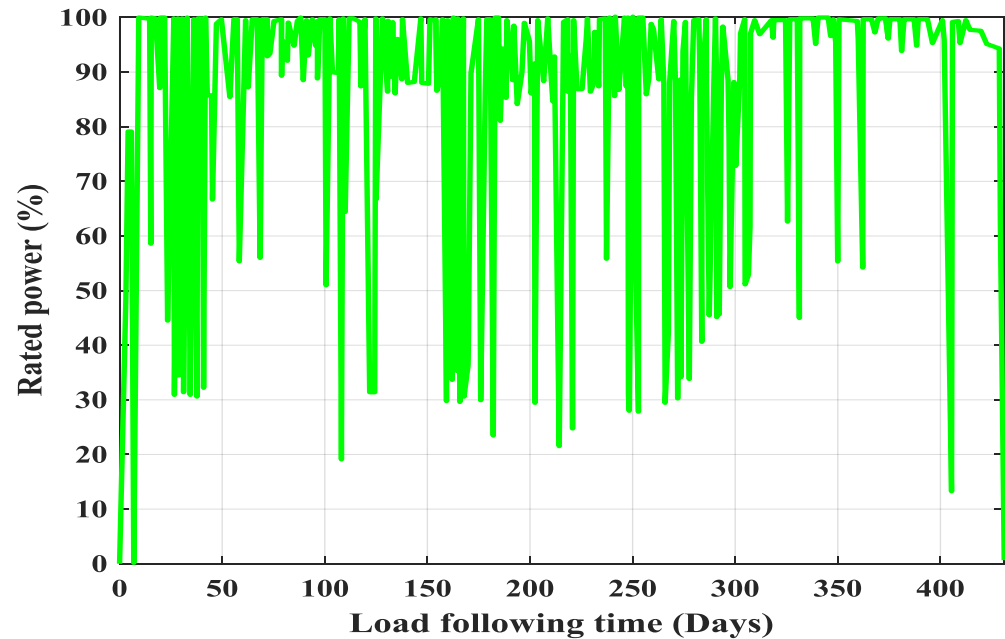

FE model information

FE model of 2-loop PWR RPV and its nozzle

FE model

- RPV and nozzles modeled.
- Heat transfer & thermal-mechanical stress analysis performed under typical grid load-following condition.
- Earlier estimated 508 LAS material properties used.
- Constant amplitude test based half-life material properties used for elastic-plastic stress analysis.

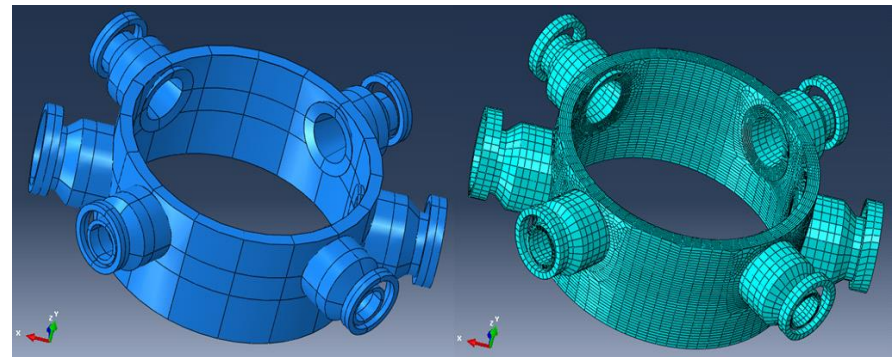
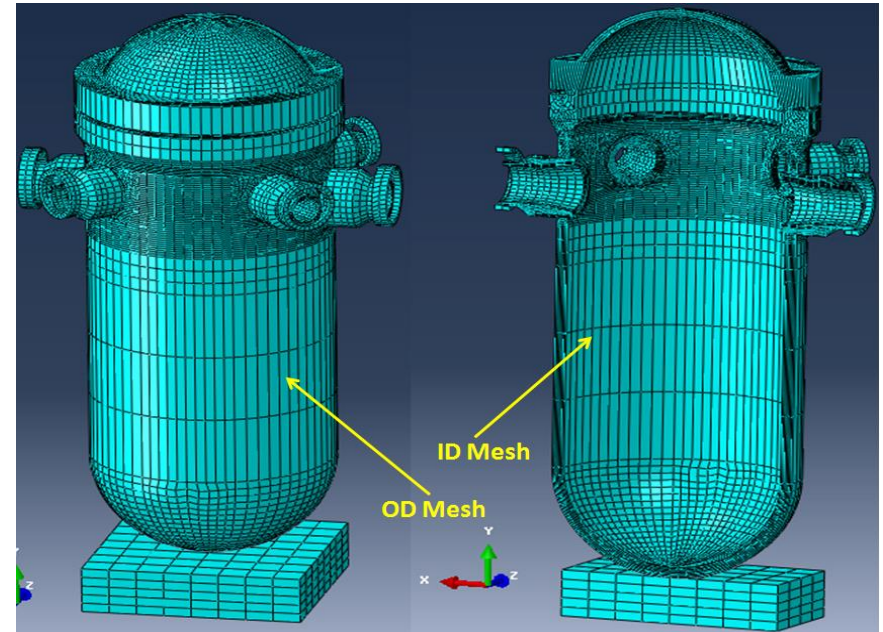

Heat transfer analysis results under grid load-following

Temperature boundary condition:
Heat-up-cool-down condition

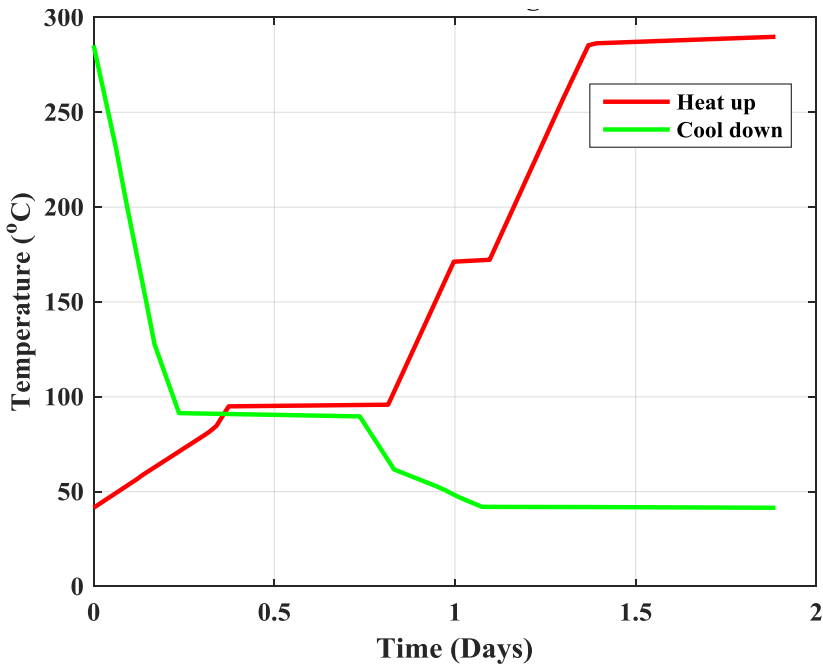

Temperature boundary condition: normal
operation load-following condition

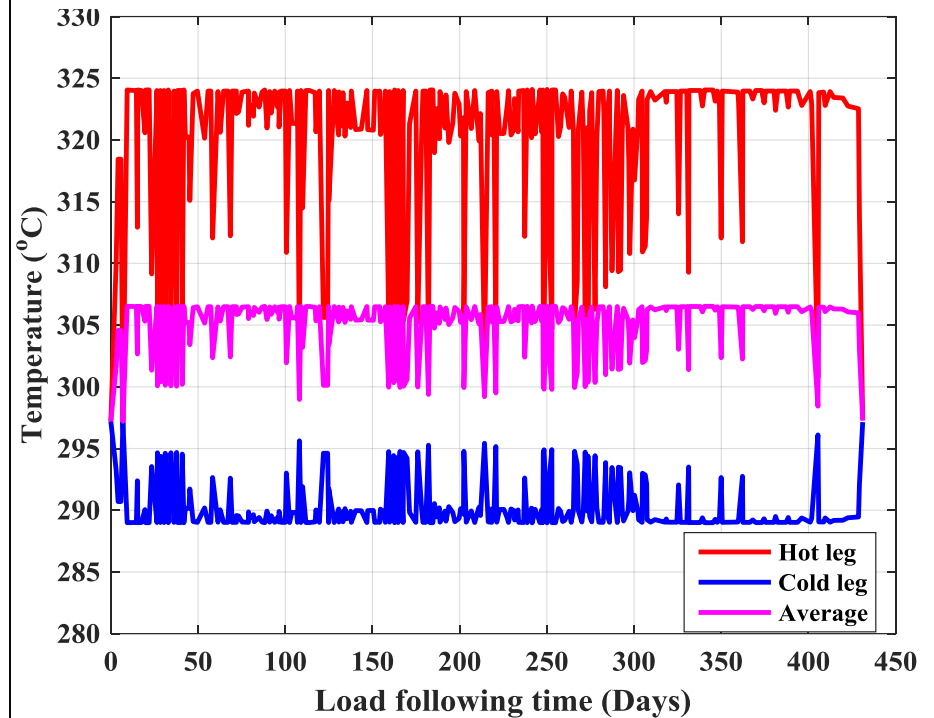

Heat transfer analysis results under grid load- following (cont.)

Temperature time-history across HL nozzle thickness with OD surface ambient boundary condition

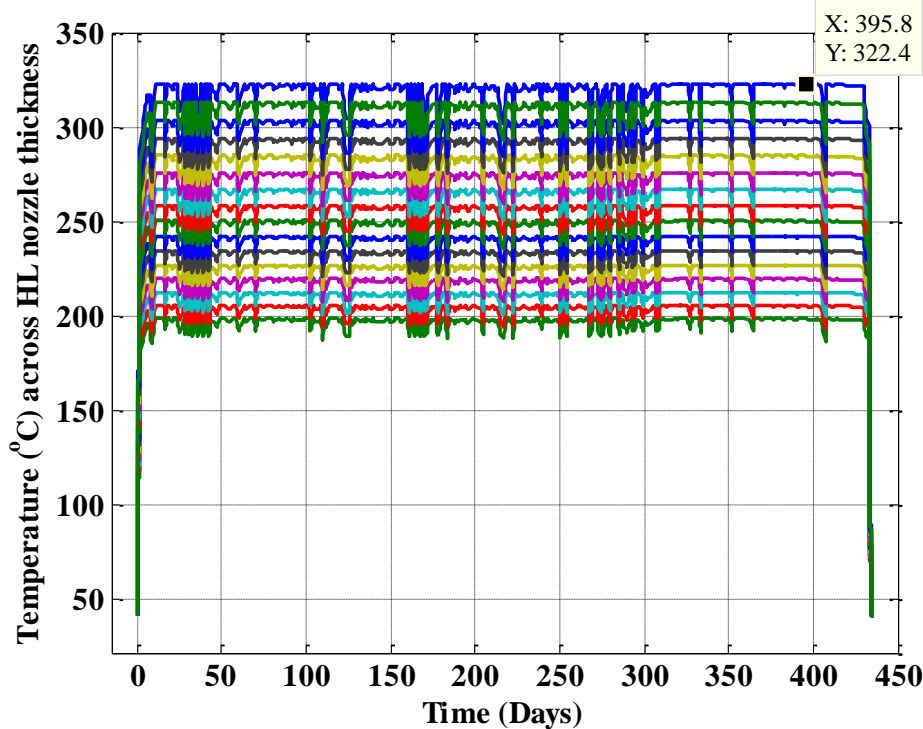

Temperature time-history across HL nozzle thickness with OD surface insulated boundary condition

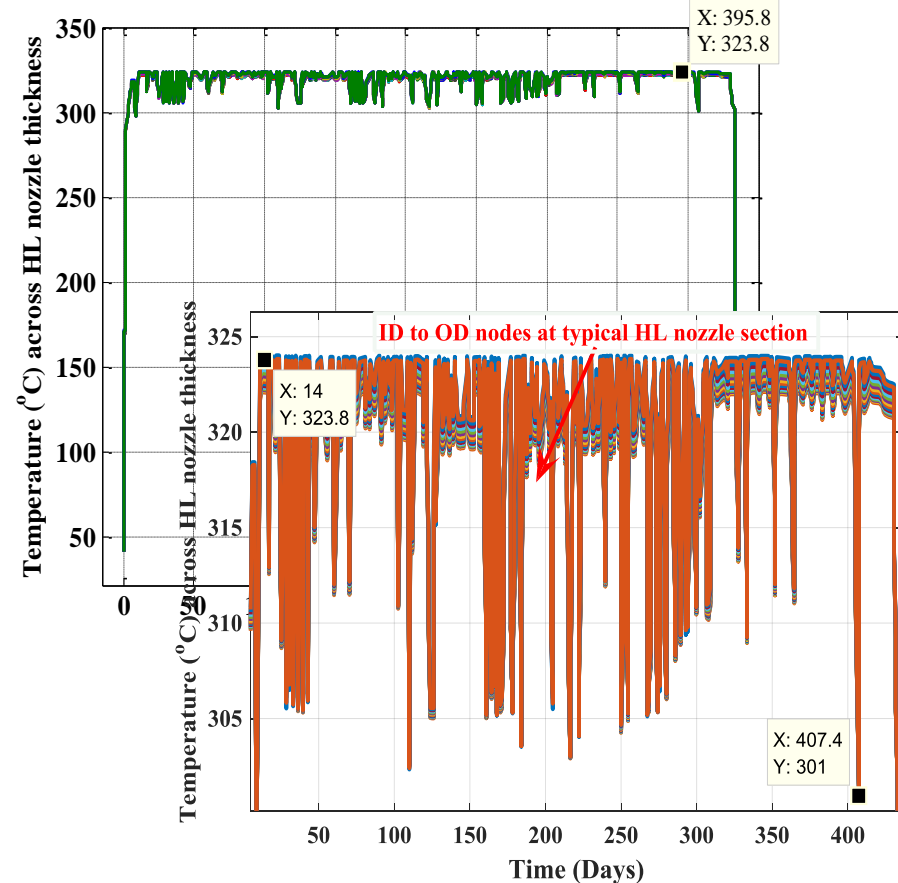

Heat transfer analysis results under grid load- following (cont.)

Temperature distribution (approximately at 391.09 days) with OD surface
a) Ambient and b) insulated condition

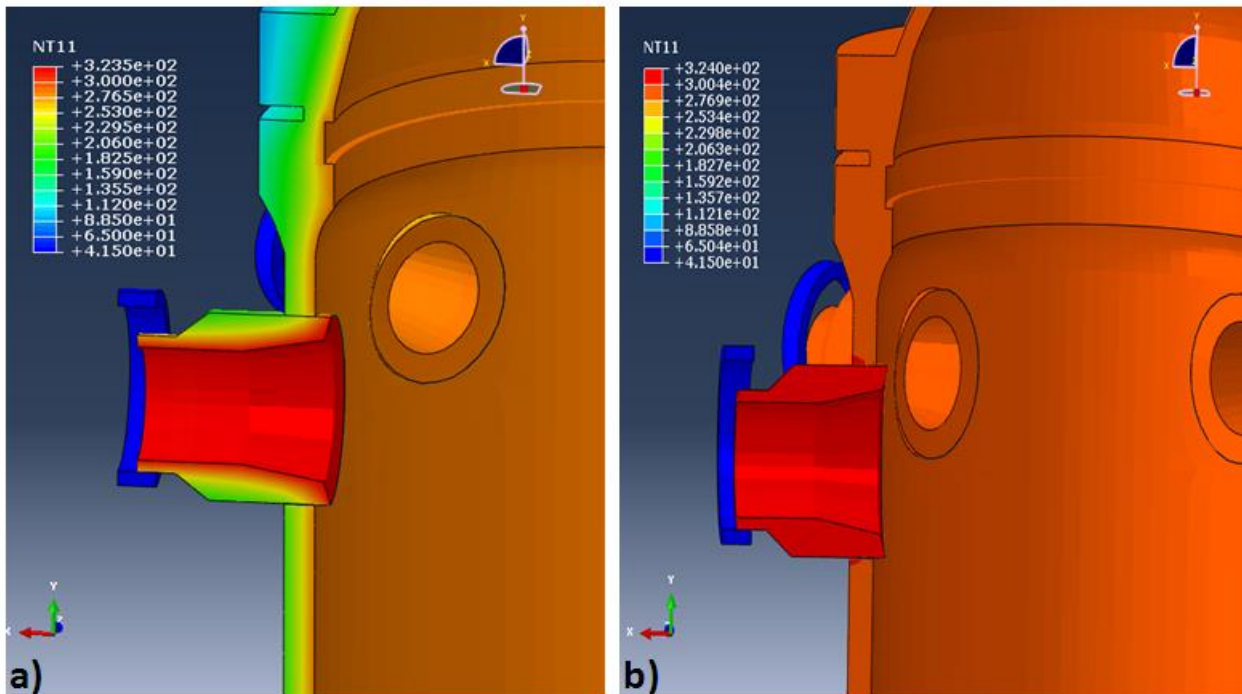

Appropriate insulation and thermal properties selection required for accurate estimation of temporal and spatial distribution of nodal temperature (for further use in stress analysis)

3D-FE Thermal-Mechanical Stress Analysis of RPV and Nozzles under Grid Load-following

(Case-1: Without presence of simulated SCC crack)

Without crack: Stress analysis results

FE model

→ Earlier estimated 508 LAS material properties (from half-life stress-strain curves of constant amplitude fatigue test) used.

→ In-air vs. PWR water condition properties used to check the effect

FE estimated thermal strain at typical element of CL nozzle

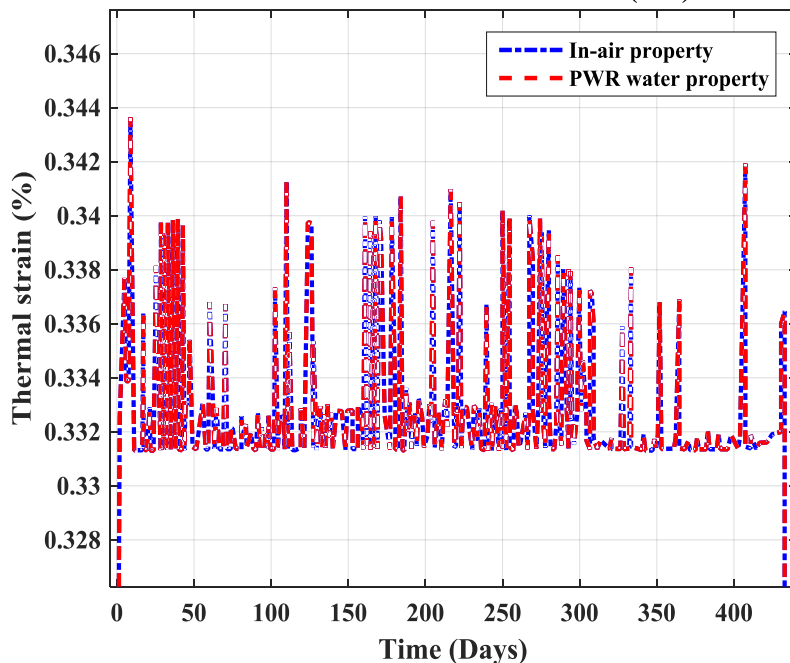

FE estimated thermal strain at typical element of HL nozzle

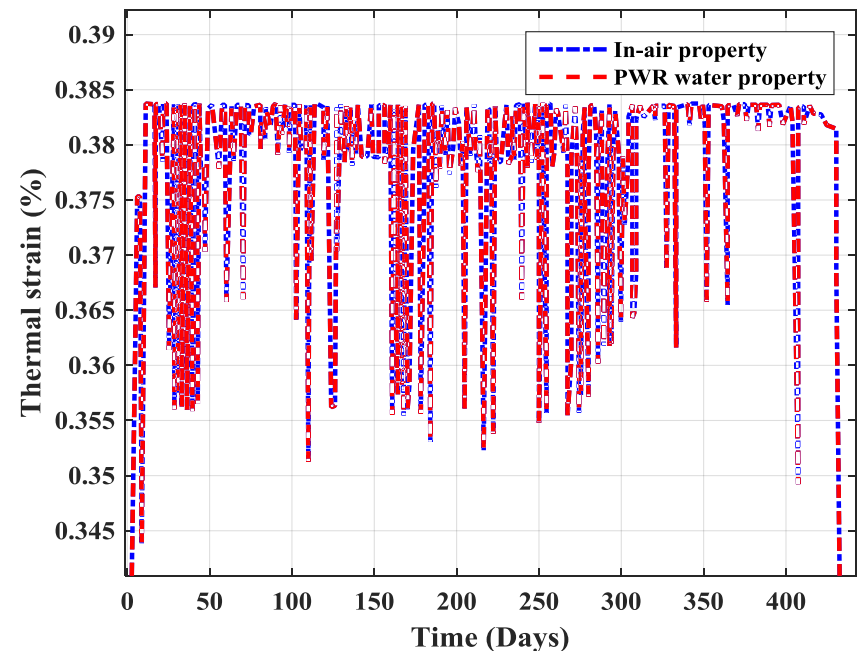

Without crack: Stress analysis results (cont.)

FE estimated total strain at typical element of CL nozzle

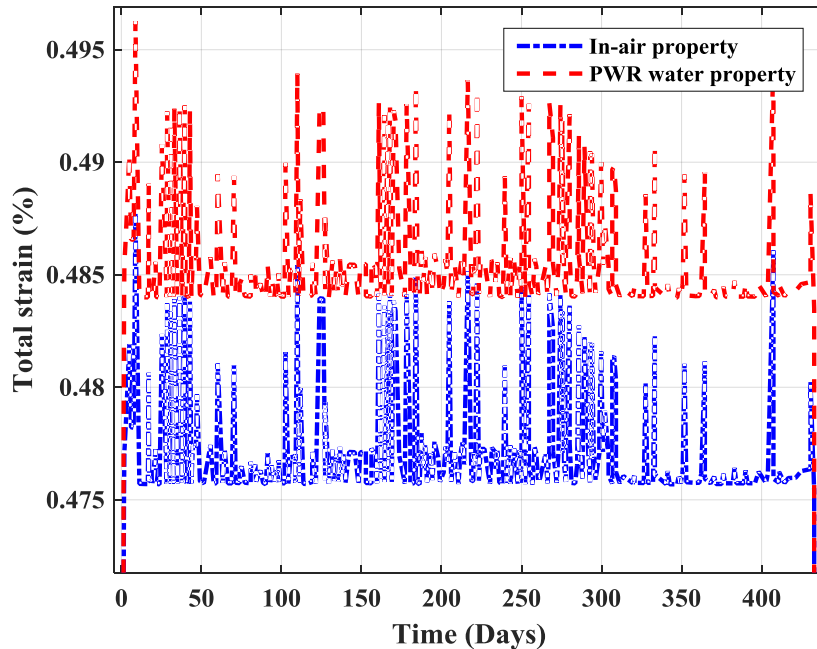

FE estimated total strain at typical element of HL nozzle

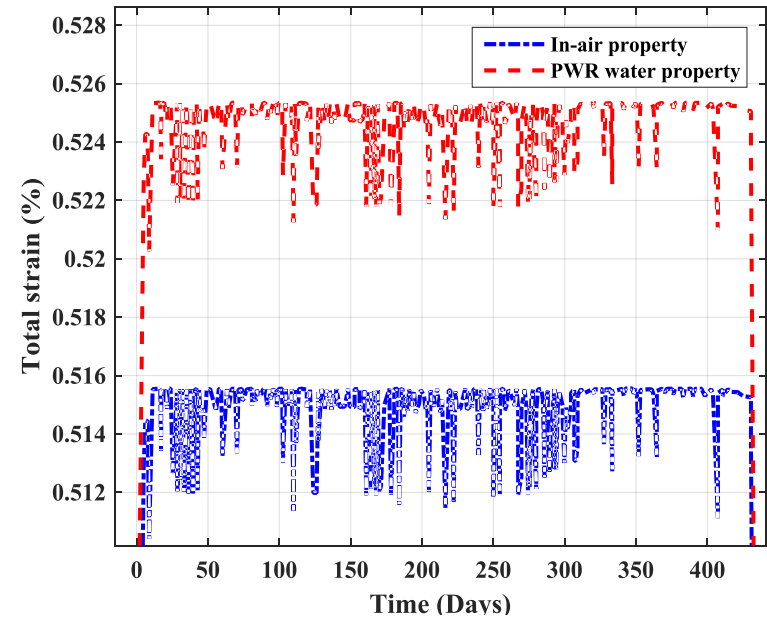

The overall aim of ANL's LWRS work objective is to capture the effect of environment, mechanistically (e.g. through generic material properties) rather than through end of life based stress-life curves.

Without crack: Stress analysis results (cont.)

Example temperature & stress distribution in RPV nozzle area at different time (during heat-up operation)

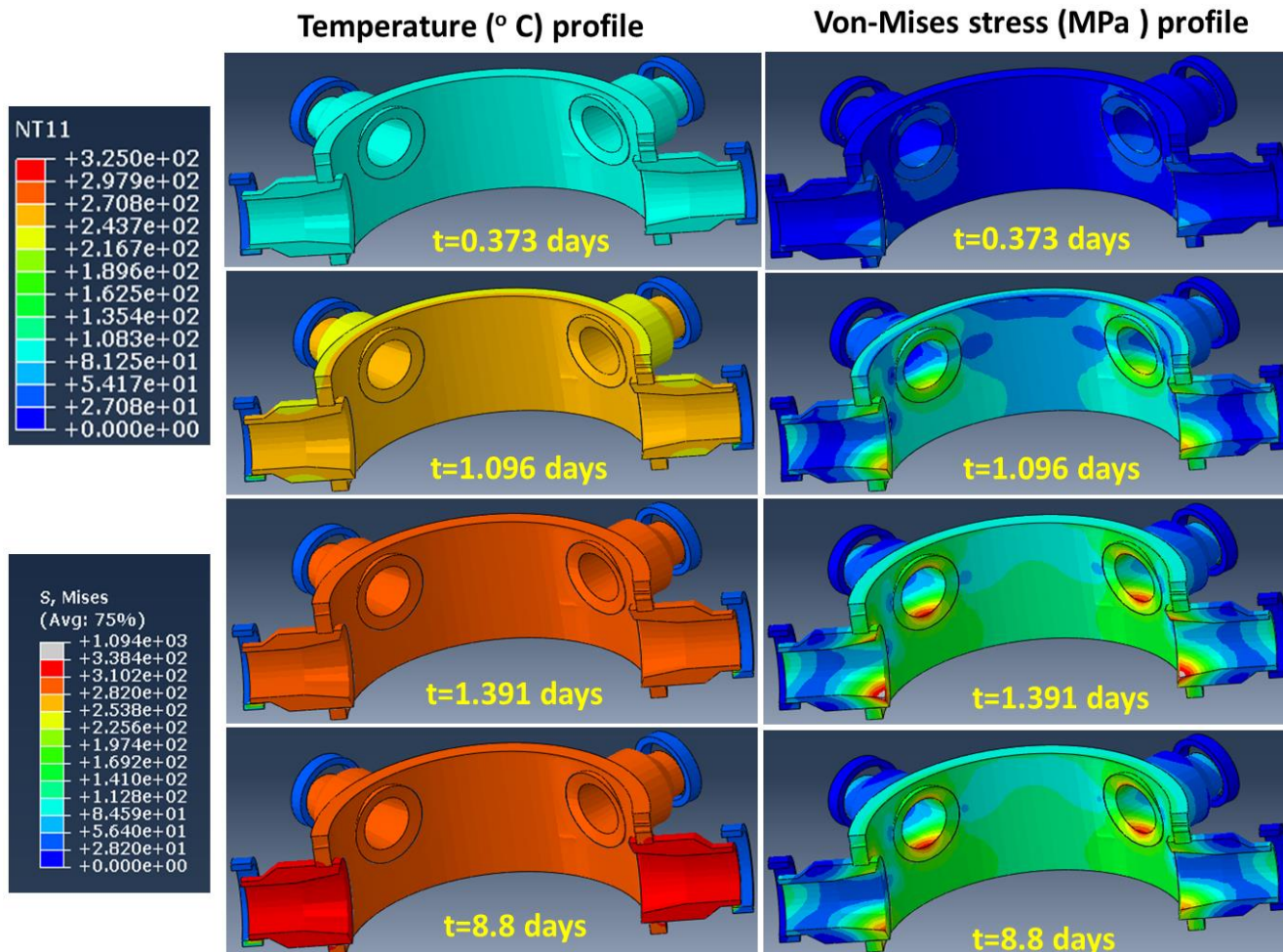

3D-FE Thermal-Mechanical Stress Analysis of RPV and Nozzles under Grid Load-following

(Case-2: With presence of simulated SCC crack)

FE model information

- A simulated SCC crack modeled to the ID surface of left HL nozzle using ABAQUS/XFEM.
- Both axial and circumferential crack modeled.

Location & shape of axial crack w.r.t left HL nozzle

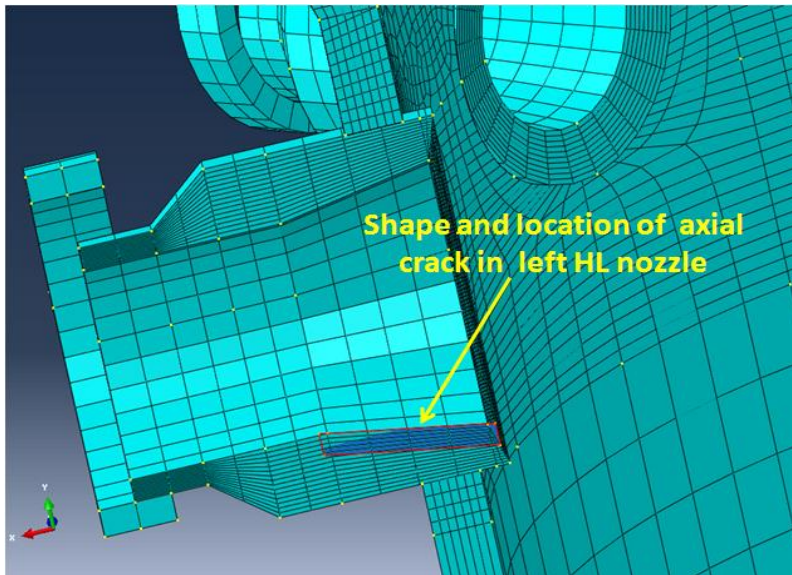

Location & shape of circumferential crack w.r.t left HL nozzle

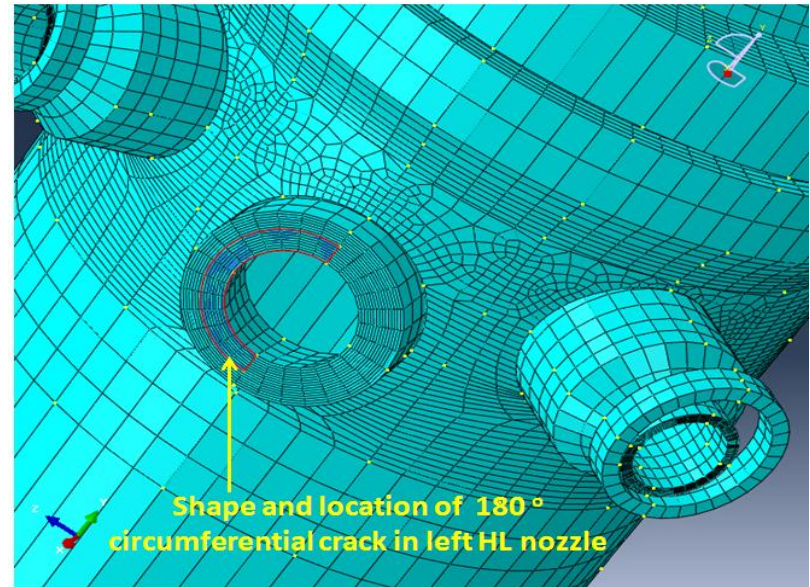

With crack: Stress analysis results

Axial crack: Stress time-history at typical left & right HL nozzle node

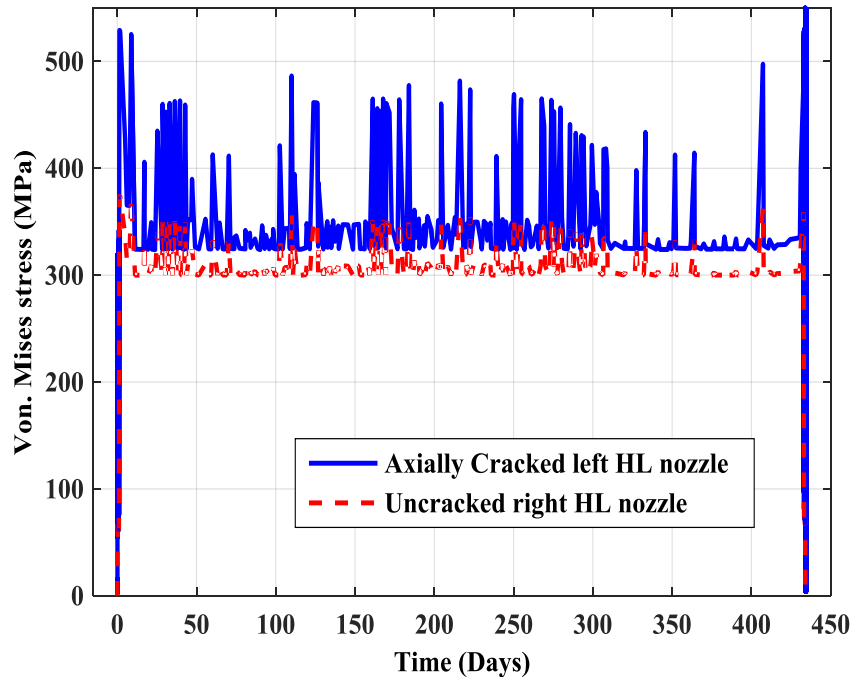

Circumferential crack: Stress time-history at typical left & right HL nozzle node

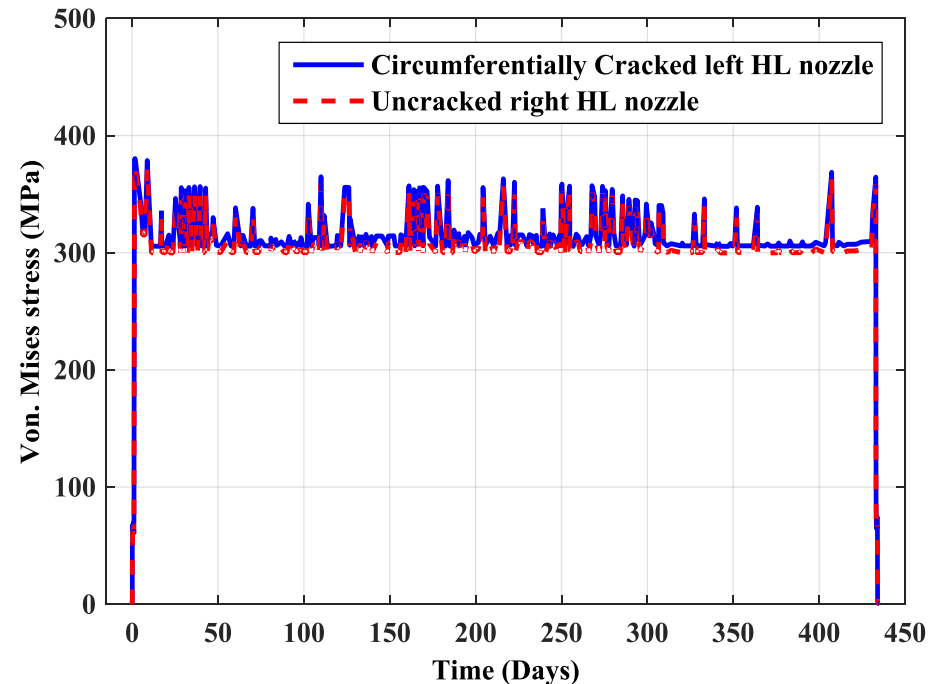

→ This results show that axial crack produces higher stress compared to circumferential crack.

→ Probably could be the reason why a axial through-wall crack grew in VC Summer NPP HL nozzle

Example evolution of accumulated plastic strain at crack site

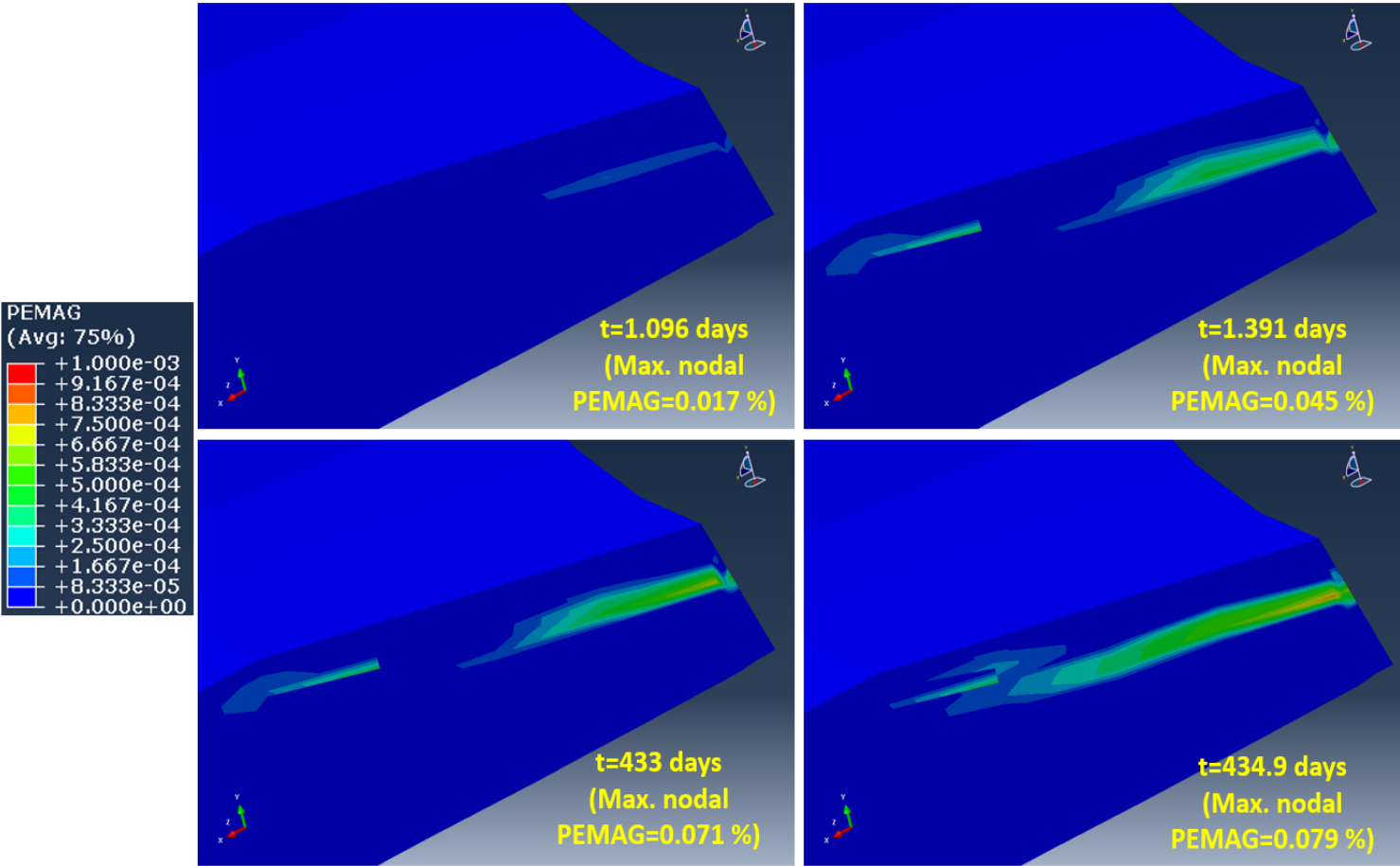

Animation: Stress distribution during heat-up, grid-load following normal operation & cool-down conditions (with presence of axial crack in left HL nozzle)

Snapshot of animation

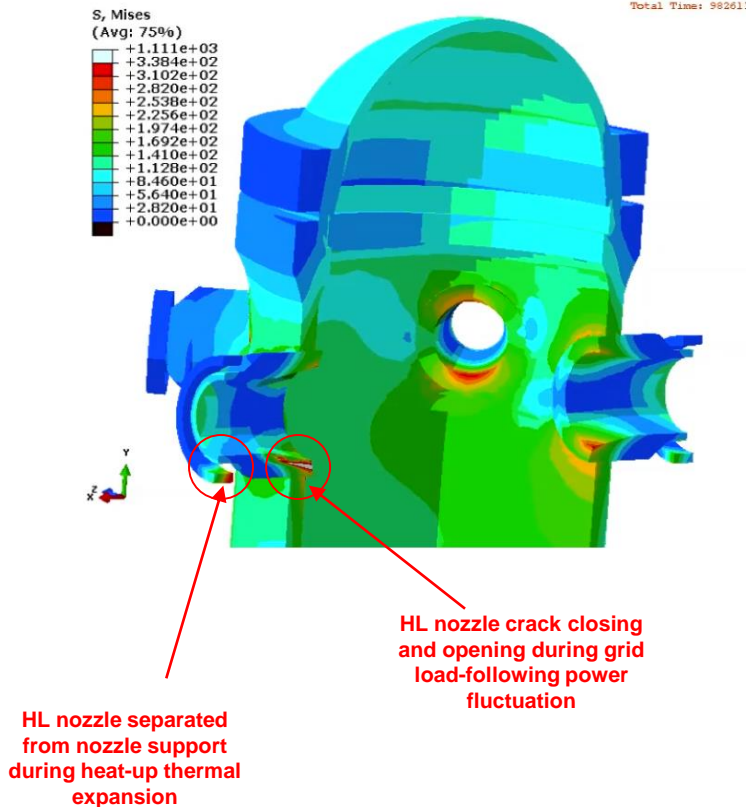

Full animation

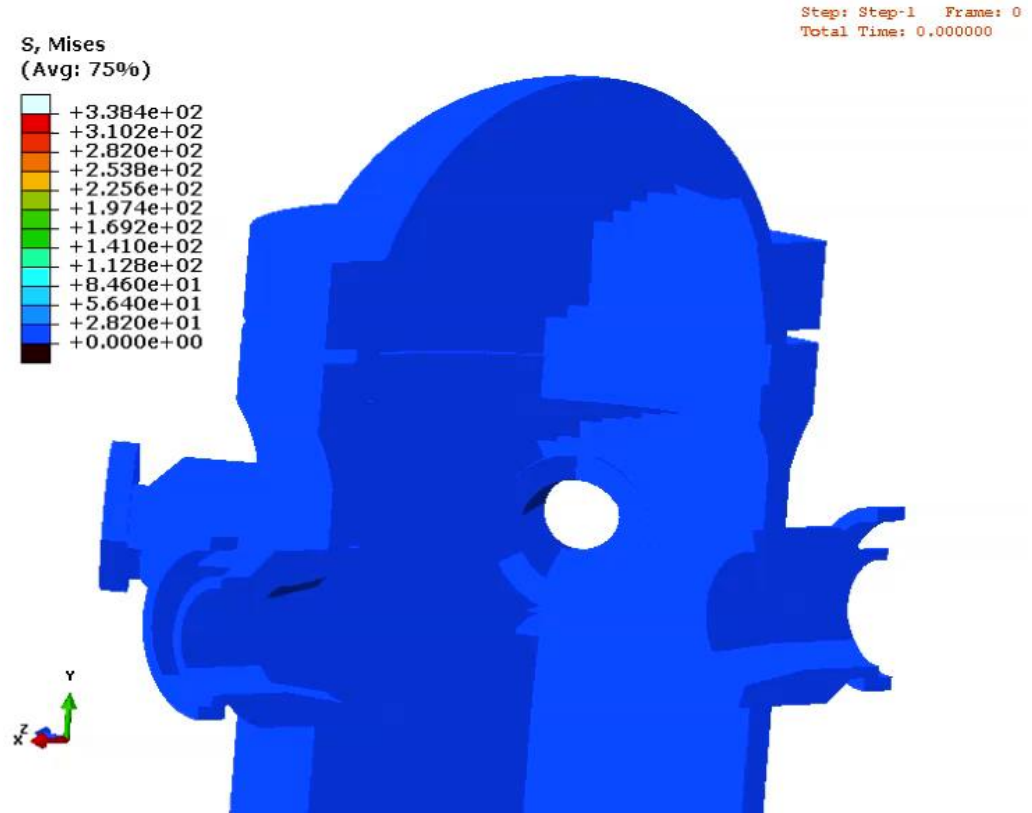

Animation: Imaginary (e.g. loss of coolant accident case) ID pressure transient (0 – 40 MPa) (with presence of axial crack in left HL nozzle)

Snapshot of animation

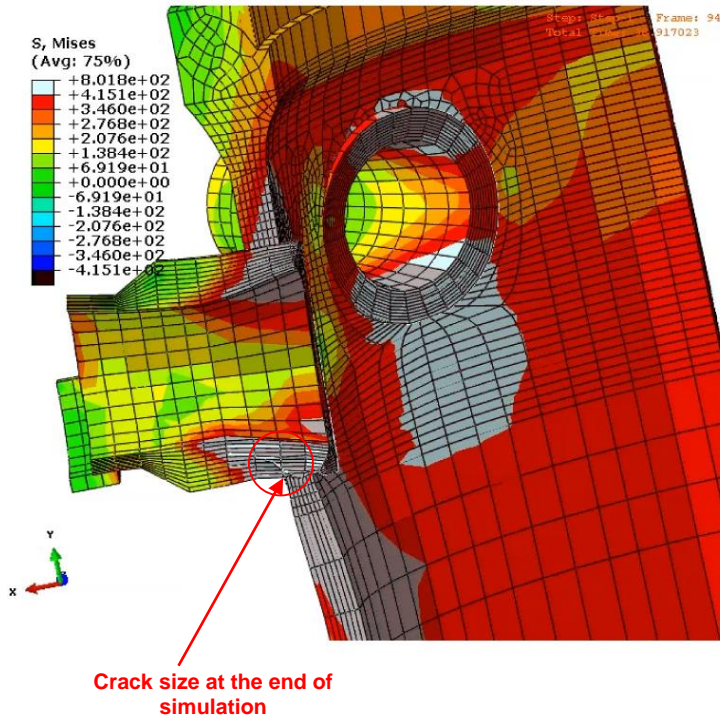

Full animation

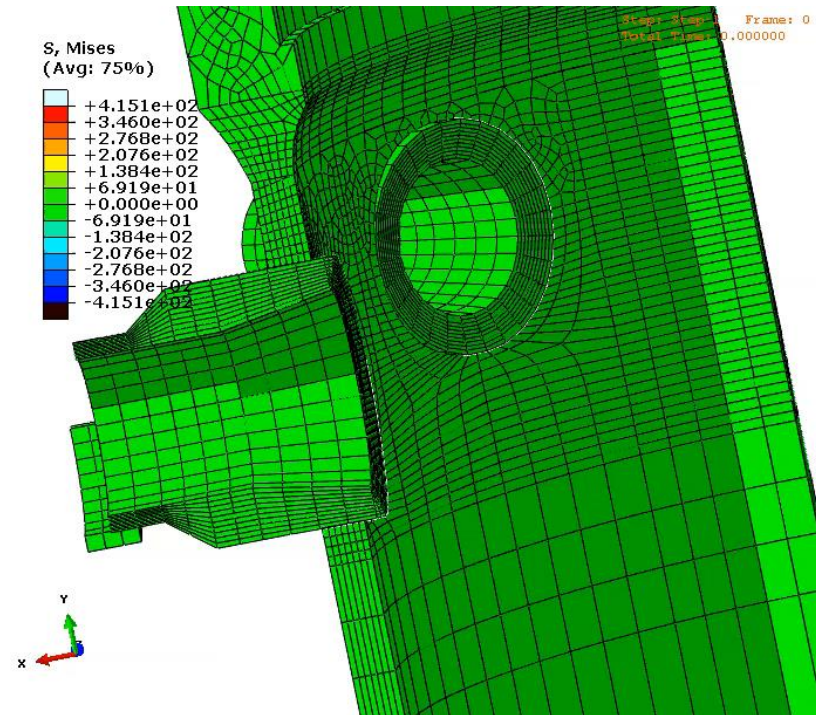

Experiment: Grid Load-Following (Random Load) Fatigue test

Preliminary experiment: Grid load-following condition fatigue test (example) results

Experiment inputs

- FE simulated stress scaled along the time axis to finish the test in a reasonable time.
- 508 LAS specimen tested under in-air and PWR water conditions.

FE results

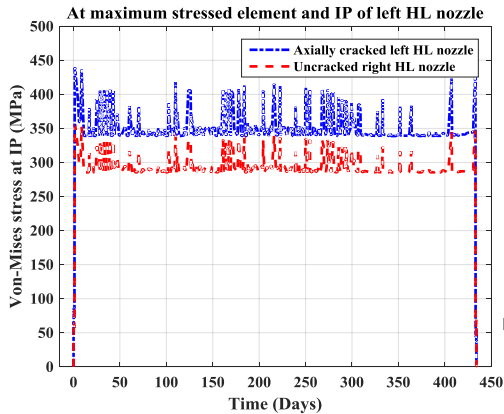

ANL's PWR water loop

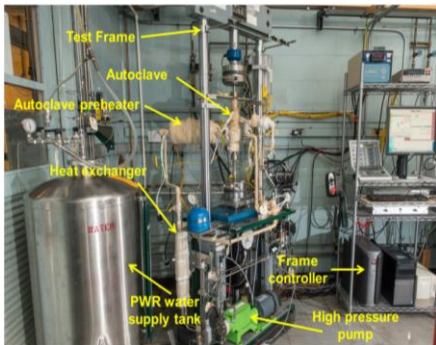

Scaled PWR water fatigue test input (as observed)

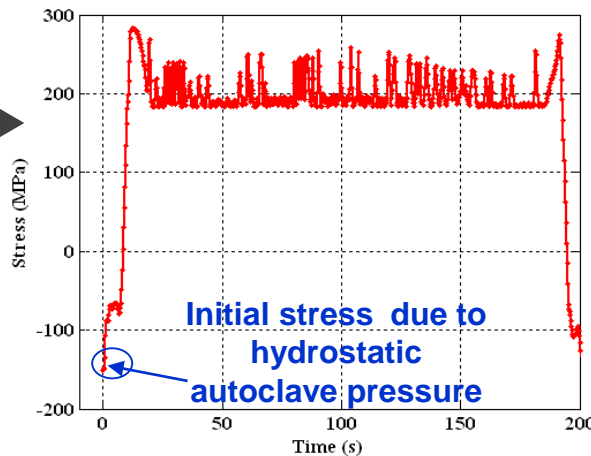

Observed stroke (1st 25 cycles)

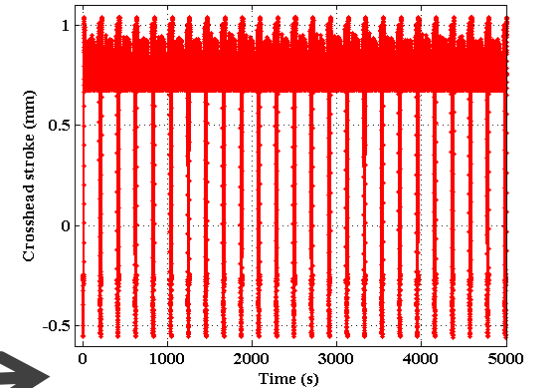

Observed stroke (1st cycle)

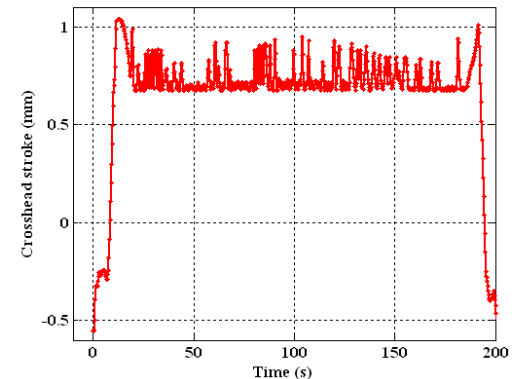

Summary

- ❑ Variable amplitude fatigue tests under in-air and PWR condition conducted and relevant material properties estimated.
- ❑ 1-D analytical model created to check the accuracy of material properties.
- ❑ 3D FE model of test specimen created to check the accuracy of constant amplitude fatigue test based material properties.
- ❑ Preliminary 3D FE model created for thermal-mechanical stress analysis of RPV and nozzles under grid-load following conditions.

Future (FY-17) Research Plan

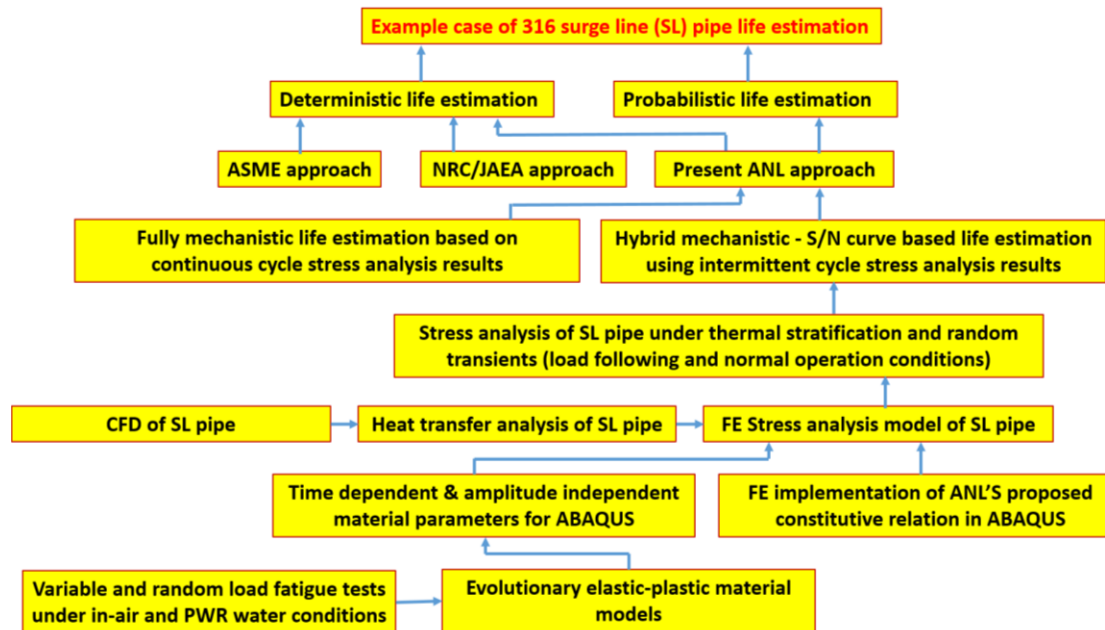

Some LWRS publications published during FY-16

- ❑ Mohanty, Subhasish, William Soppet, Saurin Majumdar, and Ken Natesan. *Tensile and Fatigue Testing and Material Hardening Model Development for 508 LAS Base Metal and 316 SS Similar Metal Weld under In-air and PWR Primary Loop Water Conditions.*, (September, 2015), Argonne National Laboratory, Report No. ANL/LWRS-15/02 (<http://www.osti.gov/scitech/biblio/1224989>).
- ❑ Mohanty, Subhasish, William K. Soppet, Saurindranath Majumdar, and Krishnamurti Natesan. "Full-scale 3-D finite element modeling of a two-loop pressurized water reactor for heat transfer, thermal–mechanical cyclic stress analysis, and environmental fatigue life estimation." *Nuclear Engineering and Design* 295 (December, 2015): 374-387 (<http://www.sciencedirect.com/science/article/pii/S0029549315004641>).
- ❑ Mohanty, Subhasish, William Soppet, Saurin Majumdar, and Ken Natesan. *Thermal-Mechanical Stress Analysis of PWR Pressure Vessel and Nozzles under Grid Load-Following Mode: Interim Report on the Effect of Cyclic Hardening Material Properties and Pre-existing Cracks on Stress Analysis Results.*, (March, 2016), Argonne National Laboratory, Report No. ANL/LWRS-16/01 (<http://www.osti.gov/scitech/biblio/1249554>).
- ❑ Mohanty, Subhasish, William K. Soppet, Saurindranath Majumdar, and Krishnamurti Natesan. "In-air and pressurized water reactor environment fatigue experiments of 316 stainless steel to study the effect of environment on cyclic hardening." *Journal of Nuclear Materials* 473 (May, 2016): 290-299 (<http://www.sciencedirect.com/science/article/pii/S002231151630037X>).
- ❑ Mohanty, Subhasish, William K. Soppet, Saurindranath Majumdar, and Krishnamurti Natesan. "Chaboche-based cyclic material hardening models for 316 SS–316 SS weld under in-air and pressurized water reactor water conditions." *Nuclear Engineering and Design* 305 (August, 2016): 524-530 (<http://www.sciencedirect.com/science/article/pii/S0029549316301649>).
- ❑ Mohanty, Subhasish, Saurin Majumdar, and Ken Natesan. "Steam generator tube rupture simulation using extended finite element method." *Nuclear Engineering and Design* 305 (August, 2016): 697-705 (<http://www.sciencedirect.com/science/article/pii/S0029549316301923>)

Thank You

