

## California Maritime Academy

Principal Investigator: Dr. Thomas Nordenholz (Mechanical Engineering)

Co-Principal Investigator: Dr. Khalid Bachkar (International Business & Logistics)

Co-Principal Investigator: Dr. Ryan Wade Dudley (Maritime Policy and Management)

### Business

David Chang, Business Administration/International Business and Logistics

Nathan Griffin, Business Administration/International Business and Logistics

Jordan Mootz, Business Administration/International Business and Logistics

Gillian Bishop, Business Administration/International Business and Logistics

Charles Wiswall, Business Administration/International Business and Logistics

### Deployment

Thomas Herburger, Global Studies and Maritime Affairs

Cameron Leahy, Global Studies and Maritime Affairs

### Engineering

Student Lead: David Buckley, Mechanical Engineering

Zachary Domagala, Mechanical Engineering, USCG 3rd A/E License

Sarah McDonald, Mechanical Engineering

Matthew Richards, Mechanical Engineering

Alec Safreno, Mechanical Engineering

Jacob Steiner, Mechanical Engineering

## **Executive Summary**

California Wind-to-Water Solutions (CWWS) is a service company focused on providing wind powered water desalination to coastal water-stressed communities and individuals. Using a modular approach, and by sourcing refurbished turbines in the 100 kW range, our plan is to provide “pop-up” wind farms in coastal locations to provide water system relief in areas experiencing drought, disaster, or otherwise unpredictable water supply conditions.

Using repurposed US Windpower 56-100 wind turbines and containerized desalination units, CWWS provides customers with small, rapidly deployable, semi-permanent desalination plants. Due to their size and modularity, these facilities can be installed in a matter of days with minimal construction equipment. By minimizing upfront capital costs, CWWS can provide affordable water purification to those who need it most, regardless of existing infrastructure.

A cost of water analysis, based on an industry accepted approach to cost of power calculations, has found the CWWS system to be capable of producing water at a cost of \$0.04 to \$0.01 per gallon, putting this system near to the range of modern desalination projects.

To illustrate CWWS’s coastal wind-driven water purification approach, a case study focused on Cambria CA has been provided. Cambria is a small community located on California’s central coast. Relying on local groundwater to meet city drinking water needs, Cambria was one of the first California cities to experience the most severe effects of the ongoing drought. As a result, Cambria has undertaken a municipal desalination project. Our case study examines the scenario in which Cambria is the first CWWS customer. The deployment plan outlines the CWWS approach for the full project lifecycle in Cambria, as well as a generalized outline of the deployment process for CWWS projects in California.

By using containerized turbines and desalination units which require minimal construction equipment for installation, CWWS has the potential to rapidly deploy projects based throughout the world, providing emergency water purification services in disaster zones, or installing long-term desalination solutions in remote coastal environments.

A model wind turbine and water purification system has been designed and built to help illustrate the CWWS approach to wind-driven desalination, and to perform a series of performance tests at the 2016 United States Department of Energy Collegiate Wind Competition. This turbine features a variable pitch control system which is novel to this competition, but is common to full-scale wind turbines like the 56-100. By varying blade pitch angle, the turbine is capable of influencing start-up wind speed, controlling rotor RPM, and braking aerodynamically.

By leveraging a rapid, iterative blade design process and testing in a student-built wind tunnel, the team has taken a design, test, revise approach to turbine optimization. Current turbine testing has resulted in power production of 30 W at rated wind speed, start-up wind speed of roughly 6 m/s, and variable pitch system validation.

## 1.0 Business Overview

CWWS is a utility service company focused on providing wind-powered desalination to coastal communities using a modular approach. Specifically, the company will focus on relieving areas experiencing droughts, water emergencies, or otherwise unpredictable water supply conditions.

Using repurposed 100 kW wind turbines and containerized reverse osmosis units, CWWS will be able to provide customers with semi-permanent desalination plants. Due to their portability and small size, these facilities can be installed quickly with minimal construction equipment and expenses. By minimizing upfront infrastructure costs, CWWS will provide affordable water purification to those in need, regardless of existing conditions. The first test of feasibility will be focusing on providing the city of Cambria (total population 6,032, avg. daily consumption per capita), located in Southern California, with fresh desalinated water.

### 1.1 Goals and Objectives:

CWWS's primary goal is to provide renewable water to drought-stressed communities. The pop-up system is designed to have a minimal environmental impact and leave no long lasting damage at the installation site. In times of adequate water supply, the system can be removed - allowing the environment to return to its natural, unaltered state. By providing a service that is affordable at the local level, CWWS will give these cities the water security they need.

### 1.2 Market Opportunity

According to the United States Geological survey, California is currently entering its fifth year of one of the most severe droughts on record. Snowpack is the primary source of water for human consumption, agriculture, and hydroelectric power (USGS "California Drought Information"). Statistics that were released on March 1st, 2016 state that over 99.67% of communities in California are experiencing abnormally high drought levels, and 82.66% are in severe to extreme levels of drought, Figure 1.1. Many of these communities are located where large-scale water reclamation systems are infeasible due to the high capital costs, topography, small population, and local regulations. CWWS will provide these areas with a sustainable source of water. CWWS's small-scale system offers alternatives to municipalities that are in need of unconventional water solutions.

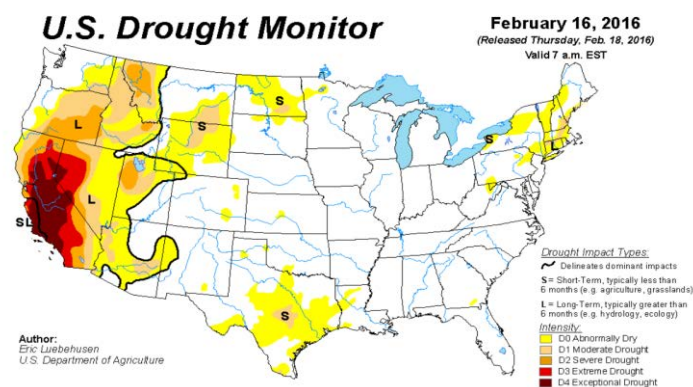

Figure 1.1: Current CA Drought Status

#### 1.2.1 Market Opportunity Forecast

The New York Times reported earlier this year that 40,000 people in rural areas and 17 communities were in danger of running out of water. Furthermore, over 700 households now have no access to running water. Since California's population is projected to grow by 600,000 people per year, demand

for a potable water supply will increase (Medina). The water utility service industry is notoriously difficult and traditionally run by local governments. Return on capital is quite small, and there can be dramatic swings in profitability. The Five Forces Analysis (see Appendix A) based on the Cambria case helps to identify the facts behind this. This analysis provides new insights into the implications of CWWS’s company strategy and brings an understanding of the internal operating dynamics, and external environment in which the company operates. As it can be seen from the Five Forces Analysis there are limited suppliers in this industry with little product variation.

Figure 1.2 illustrates the significant and sudden decline in water deliveries by the Cambria Community Utility District along with the average historical base water rates. The ability to deliver water has been severely curtailed by water rationing limiting the ability to generate revenue. Baseline water costs are artificially low and show that moderate increases in usage fees are feasible. This establishes the market opportunity which exists in Cambria CA.

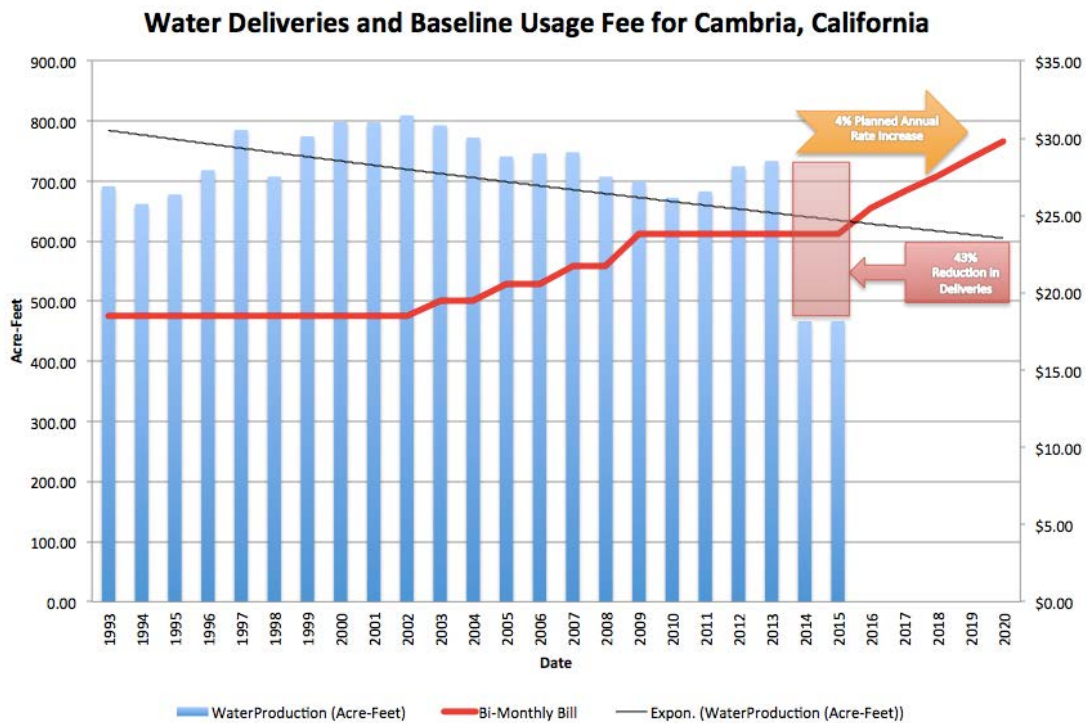

**Figure 1.2: Cambria CA water delivery and billing trends**

Increasingly, desalination has been a proven mechanism for providing a new source of water supply; this is especially true in California. CWWS consulted the East Bay Municipal Utility District, which provides water and sewage treatment to approximately 1.3 million customers, regarding the company concept (East Bay Municipal Utility District). After meeting with these professionals, it became apparent that the target market would be low-population municipalities who are not served by regional water districts. CWWS’s target market will consist of coastal cities with populations under 15,000 that are heavily dependent on imported water from the State Water Project. Because these communities have small populations and are located outside of densely populated areas, here the service will provide the most return on equity.

These cities lack the capital, land, and technical knowledge for large-scale water projects. Due to their minimal tax base, massive infrastructure projects would require more financing. CWWS will enable local

governments to install a desalination system with minimal capital costs, without pre-existing infrastructure, and with reduced regulatory impediments.

### **1.2.2 Customer Value Proposition Analysis:**

CWWS will provide customers with unique benefits not possible from other alternatives. The main advantage is the sustainable source of fresh water to improve California's drought-stricken coastal communities and environment. Communities can benefit from CWWS's services because the company will provide drinkable water quickly at a low cost, especially in an emergency state. This water will come from an independent and sustainable source that is not reliant upon precipitation patterns or the California State Water Project. The only obligation required of the municipality CWWS is serving the wind pattern data and water analysis as well as the water infrastructure.

A major perk of engaging with CWWS is the company's ability to provide an all-encompassing service. This package will include planning and installation, as well as preventative and routine maintenance throughout the entire duration of the contract. CWWS will not hesitate to go above and beyond to ensure the health and success of a community as they will not be able to find this level of commitment from other water providers. This "pop-up" service allows the limited number of turbines to be augmented or removed at any point, so there is no requirement for existing infrastructure. Essentially, communities are expected to charter CWWS because the company provides an immediate solution without requiring the community to undertake the additional stress of having a permanent wind farm or desalination plant.

California supports environmental stewardship through state legislation limiting carbon outputs and promoting renewable energy. Per state initiatives such as the Clean Energy and Pollution Reduction Act, renewable resources must become the standard, not an afterthought. CWWS's primary focus is on providing water to distressed communities, but the underlying theme in CWWS's is improving California's environment. The company will deliver water back to an environment devastated by the current drought. When the purified water is ready for consumption, CWWS will release it back into the aquifer, allowing it to recharge and rehydrate the landscape. If the community does not have a water table, CWWS will analyze the particular situation of the city by using the municipality's local expertise to tailor a unique approach that best fits the geography and infrastructure of the area. Examples of this would be a reservoir or a water tower. Additionally, CWWS's wind turbines will adhere to a strict emission-free standard to ensure the continued success in an environment that is increasingly focused on renewable energy.

### **1.2.3 Target Market**

CWWS will focus its efforts on cities and municipalities that meet the following criteria:

- Affected by severe drought
- Population below 15,000
- Do not receive water from large municipal utility districts or the California State Water Project
- Reliant upon groundwater
- Located near a saltwater source
- Have suitable wind resource

CWWS will be entering into a niche field with few substitutes. Many of these small localities are dependent upon water delivered via the California State Water Project. CWWS can target small

communities and provide them with a plan that will fit their municipality specifically, with a custom designed desalination system which optimizes all aspects from power production to brine disposal.

#### **1.2.4 Advertising**

Due to the unique nature of CWWS, advertising will be targeted at municipalities and utility districts. CWWS will contact the leaders of these organizations directly to pitch an inclusive and custom tailored service. The company will also attend events such as the California Municipal Utilities Association annual conference to network, and present the service. Advertising strategy will emphasize CWWS as a “green” service, providing a “leave no trace” solution to drought. It will be the duty of the outreach coordinator to contact communities that will benefit from CWWS.

#### **1.2.5 Pricing**

CWWS maximizes the value created by their unique product with a unique pricing strategy. Since CWWS is targeting small coastal communities, it would be possible to use this as an advantage. These cities can sell municipal bonds and secure funding to pay for municipal projects. CWWS can leverage this when attempting to raise capital. Due to the semi-permanent nature of the service, CWWS will offer a leasing agreement. Once the specific needs of each community have been met and a Memorandum of Understanding (MOU) signed, CWWS can the develop a unique and site-specific plan which will include monthly pricing and the initial origination fee. The monthly fee would cover all aspects of operations, maintenance and continued support efforts. While working to keep costs at a minimum, CWWS would still set its pricing in a way that would allow it to pay off our debts as well as generate revenue. For instance, the city of Cambria could be provided with 7 gallons of water per day per person per day, comprising 16% of daily usage. This level of production will require three turbines and 9 reverse osmosis units. To begin operations \$4,000,000 in financing would need to be secured via lenders with interest rates near 7%. The monthly fee CWWS would charge Cambria will be \$95,000 per month to provide the 16% of Cambria’s water need. At this fee rate, annual revenue would amount to \$1,140,000. Although this amount is insufficient to cover all costs in the first year of operation, the stipulation of a 5-year contract will yield \$287,000 in total net revenue over the lifetime of the contract. As the contract nears its end renewal terms can be re-negotiated in a way that favors both CWWS and the customer.

#### **1.2.6 Costs**

The upfront investments in the purchase of decommissioned turbines from the Altamont Pass from PowerWorks, and the GE desalination units are expected to be the largest single-source capital expenditure. With the rapid phase-out of these wind turbines over the next few years, acquisitions should be focused on initial large orders to ensure access to spare parts while limiting supply for potential rivals. The rapid decommissioning of these units from their current locations creates a unique opportunity to acquire assets at low costs that will then result in lower operating costs for the city we are serving. We have identified the following expenses:

- Installation Equipment
- Installation-Related Labor
- Turbine
- Desalination unit
- Pumps
- Met Station/ Anemometer
- Misc. hoses, fittings
- Brine Management
- Salary Expenses
- Operations & Maintenance
- Initial Loan Costs
- Financing Expenses
- Permit Requirements/Fees
- Transportation Costs

### 1.3 Competitor Analysis

CWWS's competitors will not be other energy producers. Instead, the firm will compete with water providers, such as the California State Water Project, solar desalination, water delivery services, and ground water from the local aquifers. The advantage that CWWS offers is high sustainability at a low-cost (see Appendix A). Another firm in the wind-powered desalination sector is a Massachusetts-based company known as Wind4Water. The company is a subsidiary of the Associated Energy Developers: a group with several units involved in renewably-powered desalination units. Wind4Water deploys a similar design of portable wind turbines in conjunction with reverse osmosis water systems. Our competitive advantage is that we are located in California, which is our initial target market. Familiarity with California's environmental concerns, specific environmental issues, and regulatory environment, as well as physical proximity to customers, will be a significant advantage over out-of-state competitors.

Brackish desalination is often considered less costly than seawater desalination. This is because it requires less energy to purify because of less dissolved salt in the water. Wind Energy Desalination can be inexpensive compared to more conventional methods of energy use since it's renewable and clean. In the long term initiative, it would cost less. Another reason to support this analysis specifically in California is Governor Brown's proposal of the 30% reduction in emissions by 2030.

### 1.4 Management Team

The CWWS management team will be as follows:

1. **Chief Executive Officer (CEO):** The CEO will direct the company toward a successful future through careful oversight, mindful decision making, and long-term strategic planning. The CEO is integral to the well-being of CWWS and will lead the company toward a sustainable future.
2. **Chief Financial Officer (CFO):** The CFO of CWWS will be in charge of financial operations. The CFO will secure funding, maintain a budget, manage assets and liabilities, and craft specially tailored pricing plans for each individual community.
3. **Outreach Coordinator (OC):** The OC will be in charge of spreading the word about CWWS and will be the point of contact for potential and current customers. The OC will also seek out new opportunities to aid communities in need.
4. **Operations Manager (OM):** CWWS's OM will be the ultimate authority on logistical matters. The transportation and implementation of the field operations will fall under the responsibility of the OM. The OM will ensure the day to day activities of CWWS are conducted in a timely and cost-effective manner. The engineers on site will report to the OM, and the OM is a peer to the OC.

### 1.5 Development and Operations:

CWWS's objective is to provide planning, installation, consulting, and system maintenance at a reasonable price, all while meeting the water security needs of the client's community. In order to maintain cost effectiveness and reliability, refurbished 56-100 wind turbines will be purchased from Power Works. The 56-100 turbine has a long history of successful operation, and is an extremely reliable turbine - providing over 97% availability (McGovert). Many 56-100 turbines from the Altamont Pass are currently being removed and refurbished by Power Works - allowing CWWS to purchase them at a reduced cost.

Partnering with PowerWorks also allows CWWS to take advantage of their existing operations and maintenance programs in order to focus on providing unparalleled customer service. PowerWorks can

install turbines, provide training, routine maintenance, complete turbine repairs, as well as extended warranties (McGovert).

#### **1.5.1 Manufacturing Approach**

CWWS does not manufacture wind turbines, or any other major system components. Rather, CWWS is focused on using refurbished wind turbines, in an effort to both minimize costs and introduce another degree of sustainability to the business model. By reusing locally available wind turbines, CWWS is minimizing the supply chain and minimizing waste. This sourcing plan presents a compelling option for customers which are concerned with environmental impacts both in power production and lifecycle sustainability.

Several companies exist which focus on refurbishing decommissioned 56-100's from California's Altamont pass. One such company is PowerWorks, which will be CWWS's primary source for turbines. In addition to providing turbines, PowerWorks will provide contracted maintenance and repair services.

#### **1.5.2 Distribution**

CWWS's distribution plan is modular. Coming to the Cambria site, for example, transportation of the turbines, reverse osmosis units, and support facilities will be in standard-sized, 40-foot shipping containers to maximize portability while minimizing transportation costs. It is possible to fit three disassembled turbines into two containers thus allowing for streamlined transportation to the project site. CWWS will contract with a third-party trucking company to complete delivery of the system to the chosen destination. Initially, CWWS will erect the turbines to establish power to the area followed by installation and connection of the desalination unit. The installation process can be completed in less than 7 days and with minimal labor hours with very few impacts to the project site. CWWS will handle all aspects of the distribution and installation except in cases where there is an agreement with PowerWorks stating that they will handle the transportation and installation.

In order to deliver the water to the utility district, CWWS will work with local professionals to find the most efficient method. For Cambria, the desalination unit will pump the fresh water into the local aquifer. For other municipalities, CWWS may need to take a different approach, but the idea remains the same.

#### **1.5.3 Research and Development**

Research and development for system improvement will be accomplished by several means. Data will be collected and analyzed to maximize the efficiency of CWWS's existing equipment and operations. With data collection and analysis, CWWS will strive to minimize the energy needed to operate reverse osmosis units, pumps, and other factors of the load. The company will also collect data to maximize the power produced by turbines. Because of CWWS's plan to source the wind turbines rather than manufacture them, CWWS will keep up to date with the latest industry news, as well as research where to source refurbished turbines, RO units, and other equipment. With the unique nature of each site, CWWS will custom tailor the equipment used to best fit the situation.

In the future, CWWS will be looking to use the latest in energy production technology such as marine energy, solar, biomass and wind. The company will also be looking to use emerging desalination processes.

#### **1.5.4 Leverage and Risk**

Increasingly, entering the wind power industry is associated with significant risks; a firm must identify and mitigate these potential setbacks in order to be successful. Some of these risks are fluctuations of customer demand, competitors, government regulations, and the high cost of assets. Setting up a wind-



driven desalination plant is an expensive undertaking, so changes in customer demand can unexpectedly make a profitable enterprise insolvent. Additionally, competitors can lower customer demand by offering competing services. Another challenge comes from government regulations, which may delay the entire operation. CWWS will leverage its relationships with turbine manufacturers and municipalities to mitigate these risks. By forming a contract with the municipality, the demand will always be present and the threat of competitors will be eliminated. A relationship with manufacturers may help lower the high cost of turbines.

### 1.5.5 Technical Constraints

CWWS uses a modular approach to wind-driven desalination, centered around two well-known components: the USW 56-100 wind turbine and the GE SeaPro-8 desalination unit. As such, the technical constraints for this business are related to the coupling of these units and the deployment of an integrated system, rather than the manufacturing of new components or systems. Most notably, CWWS will employ no energy storage components in the system, so a creative approach to utilizing variable power production is needed.

#### 1.5.5.1 Main System Component Description

The US Windpower 56-100 is a large scale production wind turbine produced beginning in the 1970's, with over 5000 units produced worldwide. These turbines consist of a 3-bladed, 56 ft diameter rotor, and 60 ft tripod tower. The 56-100 produces 100 kW at rated power. The 56-100 has a cut-in wind speed of 5.4 m/s. With a simple design and widespread presence in the wind industry, the 56-100 is readily available and easily serviced. (US Windpower)

The GE Seapro-8 is a modern, seawater desalination unit capable of producing 28,800 gallons per day (GPD) of fresh drinking water. The SeaPro requires 29.9 kW to maintain rated water production levels, and has a recovery rate of 35% from seawater up to 45,000 ppm TDS. (GE Power & Water)



Figure 1.3: US Windpower 56-100



Figure 1.4: GE SeaPro-8

#### 1.5.5.2 System Architecture and Operation

CWWS's system is centered around an operating unit, or block, consisting of one 100 kW wind turbine and three 29.9 kW desalination units. Combined in this 3:1 ratio, the desalination units will run at full capacity during rated production from the turbine, with a remaining 10 kW for auxiliary systems (feed pumps, lighting, weather monitoring, etc.). The desalination rate during rated power production will be 86,400 GPD per block on average.

Desalination blocks will continue to run and produce water during periods of below-rated power production as well. By staging the activation of each individual desalination unit, and by using VFDs to reduce system flow rate while maintaining osmotic pressure, each block will continue to produce water, albeit at a reduced rate. For example, in a scenario where the turbine is producing 60 kW, unit 1 would be operating at 100% capacity (29.9 kW), unit 2 would be operating at 67% capacity (20 kW), unit 3

would be in standby, and 10 kW would be supplied to auxiliary systems. In this way, desalination levels follow turbine capacity factor, and water production levels will vary directly with wind speed.

Using a Rayleigh distributed wind speed model coupled with the US 56-100 power curve, it is possible to relate site average annual wind speed to capacity factor. As shown in Figure 1.5, capacity factor increases linearly after roughly 3 m/s of average wind speed. It should follow that water production rates also increase linearly as site average wind speed increases.

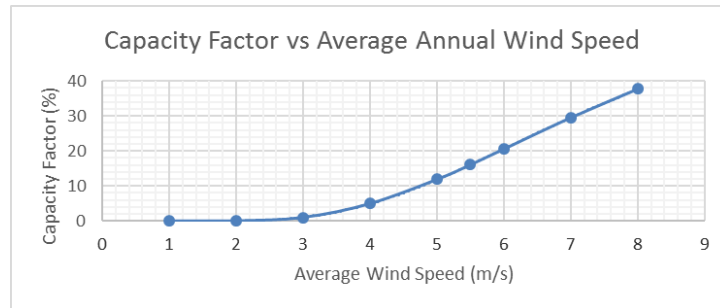

**Figure 1.5: Capacity factor as a function of average annual wind speed.**

### 1.5.5.3 Project Sizing

Because turbine capacity factor is translated to the desalination process via the configuration of the block, a block can be said to have a water production capacity factor equal to that of the turbine. For example, if the site yields a turbine capacity factor of 20% based on average annual wind speed, then each block will produce on average 20% of 86,400 GPD for a total of 17,780 GPD. All that remains is to choose the amount of water to be produced daily, and the appropriate number of blocks can be determined; for example, a city needing 50,000 GPD would need 3 blocks at a 20% capacity factor.

In this way, each CWWS project will be sized based on site average annual wind speed and desired water production levels. This allows for a wide range of project outcomes and scope. CWWS's expertise is in balancing the wind resource quality with the chosen water output level and the available size of the site to accommodate an appropriate number of blocks.

### 1.5.5.4 Excess Capacity as Water Storage

The CWWS system stores excess capacity in the form of purified water; simply put, this system makes water when the wind is blowing. Because water production rates will fluctuate continuously with wind speed and power production, each project will have need of purified water storage capacity. This need is left to the client to fulfill with CWWS performing an advisory role. Factors such as historical water consumption rates, expected wind patterns, desired water reserve levels, and many others will be taken into account when determining reservoir recommendations. In the event that reservoir capacity was exceeded, desalination operations would be temporarily suspended.

### 1.5.5.5 Water Costs

By adapting a simple cost of energy analysis (Wind Energy Explained) to this desalination process, it is possible to obtain a value for CWWS's cost per gallon of purified water. This method assumes a fixed charge rate (FCR) of 10%, and an O&M cost of 6% of capital cost per year. This cost of water production varies significantly with site average annual wind speed. Figure 1.6 plots the relationship between average annual wind speed and cost per gallon of water produced. This plot demonstrates that for sites with average annual wind speed above 4m/s, water can be produced for costs below \$0.05 per gallon using this approach.

Ideally, CWWS would seek sites which have an average annual wind speed of 7m/s or above to produce water at costs below \$0.01 per gallon, on par with modern large-scale desalination projects (WaterReuse). Recognizing that such sites are relatively rare, CWWS is likely to produce water for costs in the \$0.03 - \$0.01 range. Performing this analysis for the Cambria site, which has a low average annual wind speed of 5.5m/s, shows that CWWS can produce water at a cost of \$0.021 per gallon.

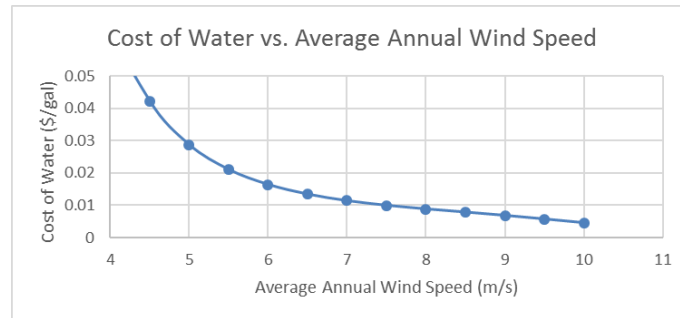

**Figure 1.6: Cost of water as a function of average annual wind speed.**

### 1.6 Financial Analysis

The key to success for CWWS rides on the ability to provide a service to communities in need. Due to record drought conditions, the demand for water is high, meaning that CWWS will have the ability to deliver solid profits and reliable income. Requiring an origination fee and monthly payments, as opposed to a large initial sum paid in full, means that profits will not emerge within the first fiscal year but will emerge during the duration of the contract. This fee-based contract model allows for appropriate fiscal planning while allowing CWWS to maintain elevated levels of liquidity to exercise new contracts if necessary. An initial loan of \$4 Million will be necessary to secure the acquisition of operational capital (e.g. wind turbines, desalination units, misc. hardware) while keeping sizeable amounts of liquidity within the company throughout the first two fiscal years. Long-term liabilities will be paid from the revenue generated by CWWS and will prove to be sustainable and consistent. An initial 5-year contract with a monthly service fee of \$95,000 will generate \$287,000 in net revenue over the course of the service agreement.

Because substantial initial capital investment necessary to implement CWWS’s services, financial analysis and forecasting are necessary to obtain an appropriate understanding of financial performance. CWWS, as mentioned before, will not be profitable within the first year of operation but achieves a profit ratio of 39% in the second year and only very slightly declining (1%) all subsequent remaining years of the operational contract. Having to secure a sizeable loan to begin operations, the Debt to Assets ratio is significant to the overall financial health of CWWS. With a 200% Debt to Asset ratio that reaches a high of 336% in the second year, a significant and continuous decline occurs over the remaining years as revenue is continually generated and long-term notes are paid off. With the facilities being leased out by contract, the pricing strategy can be carefully and accurately manipulated to produce adequate profits within the proposed time frame. After the fifth year of operations all capital costs will have been recouped, allowing for more flexibility in contract extension negotiations while maintaining options for other possible deployment opportunities. The financial sheets providing this information can be found in Appendix C.

### 2.0 Deployment Overview

The CWWS deployment plan falls in line with the overall goal of providing a complete, compact service to water-stressed communities. Utilizing the US WindPower 56-100 wind turbines to power modular

desalination units, CWWS strives to ensure the system has minimal environmental impact, is non-disruptive to the community, and complies with all regulations when possible. It is CWWS's goal to provide clean drinking water to communities in need while operating in a safe location and under established guidelines.

## **2.1 Project Site Evaluation and Selection**

Project site evaluation and selection is vital to the overall success of the service provided by CWWS. It is therefore with great care that each potential project site be properly evaluated and determined to be appropriate. The evaluation process will include multiple components such as proper geographical space for the turbine(s), desalination plant, and relevant peripheral equipment, a solid, geologically sturdy ground, access to water for desalination purposes, adequate wind resources, a site far enough away from residential areas to mitigate noise complaints, and located in an area which does not negatively impact wildlife.

The geographic space needed for the US WindPower model 56 -100 turbines that CWWS will utilize is very reasonable. The 56-100 has a 56 foot swept diameter and has a 60 ft hub height. The total base area is 242 square feet. This compares favorably to larger turbine models and allows a fairly small footprint for the project. Concrete pile foundations will provide structural stability to each of the three legs of the galvanized steel, trestle style tripod tower upon which the turbine sits. A typical industry standard for turbine separation is 3 rotor diameters in the prevailing crosswind and 10 diameters in the prevailing downwind directions, respectively (Jackson). Set-back space needed for each turbine unit in California is generally one and a quarter to three times the maximum blade tip height, but this can vary by county. This means the chosen site will have the 60 ft hub height plus 28 feet for the radius of the blades for a total set-back radius of between 110 and 264 feet from the tower center. The distance of the setback is highly dependent upon county regulations. Telephone poles, electric wires, structures, and other infrastructure will not be within this space for safety concerns. While turbine structural failure is highly unlikely, ensuring the safe operation of the turbines is key to CWWS's service and as such necessary precautions will be made.

The desalination plant used will be three GE SeaPro-8 Seawater Desalination units for each 56-100 wind turbine. The GE SeaPro-8 skid measures in at 199 by 52 inches and weighs 3,400 pounds (GE). The 3 desalination units should therefore easily fit within the required turbine separation and setback areas. Taking all of this into consideration, if turbines are aligned perpendicular to the prevailing wind (typically out of the west in California), a square area of 168 ft x 168 ft = 28,200 ft<sup>2</sup> should be sufficient for each turbine/desalination block. This land may be owned by the beneficiary or by an unrelated third party. Should further costs be incurred due to this, it will be passed on to the community. For example, if the ideal site is a privately owned plot of land, it would be up to the community to determine if they are willing to provide agreeable compensation. Easement laws can provide the tool by which a city or other local entity gains access to this land, however this will once again be under the determination of local officials.

The Federal Aviation Administration restricts the height of structures to allow for the safety or air travel. This restriction limits the height of antennas to 2,000 feet. Around airports themselves, further height restrictions can be imposed. This would be particularly strict in and around the airport itself due to the lower altitudes needed for safe landing and airplane take-off (Federal Aviation Administration). However, CWWS's turbines are significantly shorter than these heights and it is unlikely to ever be a concern for the deployment process.

A further element of site selection is the concern of noise pollution produced by the turbines. The 56-100 turbine is rated to produce 45 decibels at a distance of 800 feet. According to the US Center for Disease Control and Prevention, the average decibel level produced by the humming of a household refrigerator is 40 dB (Center for Disease Control and Prevention). As such, the noise produced by the CWWS project site will have a minimal impact on the daily lives of nearby residents.

Geological surveying may be required to ensure that the ground at potential sites is sturdy enough to handle the weight of the turbine. The 56-100 turbine is comparatively small to many modern, commercial grade turbines and the combined weight of the turbine and tower comes in at a manageable 12,500 pounds (USW 100 kW Field Manual). Furthermore, the tripod design of the tower for the 56-100 provides a simple and effective means of stability. The aforementioned weight of the desalination plant is 3,400 pounds. The weight of peripheral equipment such as piping will be negligible in weight. It is therefore estimated that a single turbine/desalination block will weigh a total of 22,700 pounds. Since CWWS is a temporary project and expects to be located in an area on the order of 5 to 7 years, intensive structural support that is needed for large scale wind farms is not needed. This means that unlike other industrial grade wind turbines, the 56-100 model used by CWWS will require only a simple geological survey to assess ground conditions.

Each project site will also be chosen based on the distance to seawater. Piping will be installed to allow for the extraction of seawater to feed the desalination plant. The piping itself will be approximately 4 in industrial grade rubber pipe located above ground. In order to ensure that the seawater drawn by the desalination plant is not contaminated by matter such as sand, seaweed, and other debris, the piping will be set out at least 100 yards out from the shoreline (Storz). There would also be a pre-filter on this pipe to prevent the intake of marine life and other large particles prior to pumping into the desalination unit.

The fresh water produced by the desalination plant can be used to replenish established fresh-water resources. This aspect of the deployment process will depend on the needs of the customer. CWWS is not a water distribution company and therefore this aspect of a project will be determined by the customer as will the costs associated with it. A number of options exist, however. Desalinated water can be used to replenish existing fresh water supplies such as lakes, rivers, well water, or even aquifers. Water trucks can be rented and large water tanks can store water at a central distribution site. Ultimately this will be a decision that the customer will make and CWWS will respond accordingly, providing a customized service to fit the needs of the community.

The discharge of brine will also be taken into consideration for site selection. Communities can, if requested, have the brine discharged directly back into the ocean or into an evaporation pond. A current desalination project in Cambria, CA utilizes a 3-acre evaporation pond for brine disposal (Sneed). Each block of the CWWS desalination plant is estimated to produce 17,280 gallons of fresh water per day when operating at 20% capacity and would produce 31,968 gallons of brine. This brine can be sent back into the ocean. Injecting brine into the ground as has been done by oil production sites has resulted in environmental concerns. Therefore, direct ocean disposal or evaporation ponds are seen as the best ways by which to dispose of the brine. Impact on marine life will be minimal when discharged into the ocean and the brine will disperse in short order.

The capacity factor and cost of water production for the CWWS desalination block were graphed in section 1.4. Utilizing established wind maps and other available resources, computer based

modeling can allow CWWS to determine the viability of potential project sites. The approximate minimum wind speed will be 5.5 meters per second.

A simple meteorological tower will be erected in order to allow monitoring of wind and weather conditions. This will include an anemometer to measure wind speed and direction and log this data. However, if a particular project has two or more turbines in place, CWWS can use the onboard anemometers and other sensors to derive the relevant data. Having two or more turbine will allow technicians to compare data derived from the two sources to check for faults or anomalies.

Keeping the project site safe and secure is another important consideration for site selection. Vandalism and theft are key concerns. There is also the potential for thrill seekers who would climb the turbine structure and place themselves at risk. A chain link fence with barbed wire will be utilized to mark off the area of the project site. Not only is are the risks of theft and vandalism a threat operation of the site, but also a risk to those individuals committing the acts. Simple security fences and routine checks from local law enforcement officials should prevent much of this.

The turbines, desalination units, and piping will not impede public access to coastal locations. Public access laws require that no unnecessary restrictions to beaches be in place. Therefore, part of the site selection process will include this component. The brine discharge and seawater extraction lines will therefore be designed and sited to be minimally restrictive to access. This may include placing them underground depending on the site.

## **2.2 Deployment Case Study: Cambria, CA**

For Cambria, the site selection process will follow existing water resource infrastructure for the best results. By doing so, CWWS will ensure that existing infrastructure can be used, expanded upon, and will follow previously approved permitting processes. The location for the turbines and desalination units will be in a rural area approximately one quarter of a mile away from the nearest residential area to minimize impact such as aesthetic and noise complaints. Based on CWWS's sizing guidelines previously stated, the Cambria site would require 4 blocks (4 wind turbines and 12 desalination units).

A security fence will be erected to cover an area of approximately 6 acres of unused land that is adjacent to roadway for ease of access. For the purposes of this example, a new injection well will be established within the vicinity of three existing wells in order to replenish the water supply. Seawater extraction and brine discharge lines will run along existing water lines before turning towards the ocean. The brine discharge line will be constructed at a minimum of 100 yards before the shoreline to ensure that the brine disperses over a wider area and therefore minimizes environmental impact. The seawater extraction line will likewise be at least 100 yards out to mitigate the intake of marine life and other debris. According to available wind maps, the site should achieve 5.5 meters per second wind average wind speed at 30 meters of elevation with prevailing western direction. A detailed map of the proposed project site as well as a wind resource map can be found below.

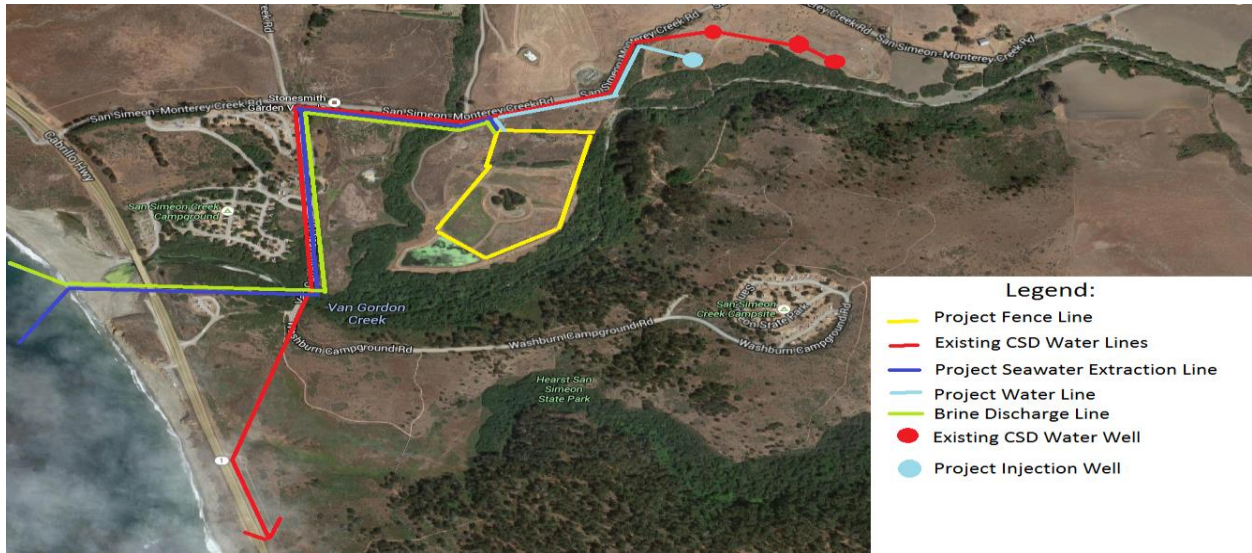

Figure 2.1: Proposed Cambria project site.

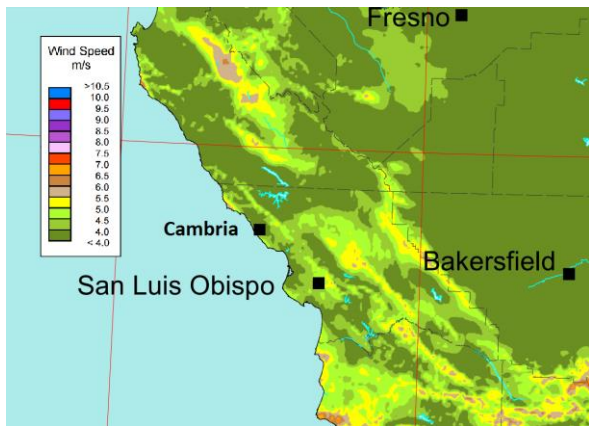

Figure 2.2: Cambria wind resource map. (WindExchange)

### 2.2.1 Stakeholder Identification and Communication

Stakeholder identification and communication is just as vital to the overall implementation of each specific project. The cities, towns, water districts, and other entities that are potential customers for CWWS’s services will be kept up to date with the development of the project. In order to ensure the customer base receives the desired product and services, CWWS will maintain transparency and identify and communicate with those individuals and groups which are relevant to the project.

CWWS will maintain open lines of communication with key stakeholders. Depending on the exact nature of contracting entity, this will include such people as city managers, city planners, city council members, the mayor, and state officials such as those on the California Coastal Commission, California Environmental Protection Agency (and its sub branch the State Water Resource Control Board), and the California Energy Commission. Other groups, which will be site dependent as well, may include various advocacy groups, environmental groups, and groups of concerned residents.

The process will begin with an open draft of proposal which will be reviewed by the stakeholders and open to public comment. Public input can be in the form of a town hall or city council meeting and a

CWWS representative will be there to answer questions and address concerns. It will be up to the local officials on how any complaints will be taken into consideration while CWWS moves forward with the project. It is with transparency and public involvement that CWWS can mitigate the risk of community pushback during the entire project lifecycle.

To further this process, CWWS will seek input from specific stakeholder groups. These groups will include environmental organizations ranging from large organizations such as the Sierra Club and Audubon Society, to smaller groups such as Friends of the Sea Otter, and commercial and recreational fishermen advocacy groups (Department of Fish and Wildlife). The concerns of impact to birds, marine life, and other wildlife are of great importance to CWWS and the service it provides.

#### **2.2.1.1 Cambria, CA Stakeholders**

The residents of Cambria are the first and foremost stakeholders for this project. They will be the consumers of the desalinated water and the ones whose concerns will be taken into serious consideration. The Cambria city manager will be the most important single contact and will be regularly kept informed about the entire process. The Cambria Community Services District (CCSD) will be perhaps the major player in the project as the CCSD is the local agency concerning itself with the local water supply. On the state level, the California Coastal Commission will also be contacted and their concerns addressed.

An environmental group called Land Watch San Luis Obispo is also an important stakeholder. It was this group that sued the district in 2015 to address concerns about a similar desalination water treatment plant (Sneed). Furthermore, Cambria is home to numerous hotels and ranchers and both of these groups have a keen interest in the water supply for economic purposes. The Monterey County Sheriff's Department, which operates an office in Cambria, will be contacted and notified of the project. This will allow the department to be made aware of the potential emergency risks such as theft and fire.

In order to achieve the level of transparency and communication that CWWS believes will be necessary for the success of the project, an authorized spokesman for the company will keep in regular contact with the editors of The Cambrian news website. This news website, which regularly publishes local news stories in Cambria, would allow CWWS to reach a wide audience within the community.

#### **2.2.2 Deployment Timeline and Project Life Cycle Identification**

The deployment timeline and project life cycle are heavily influenced by the type of aid application and circumstance(s) CWWS is deployed for. Despite unique circumstances, each deployment involves a similar process outlined as follows:

- Site Selection - 2 to 5 days
- Permitting - 1 to 3 weeks
- Installation & Testing - 5 to 7 days
- Overall Project Lifespan - contract specific
- Tear Down - 1 to 2 days
- Land Reclamation - 1 to 3 days

##### **2.2.2.1 Site Selection (2-5 days)**

Proper site selection is dependent on numerous factors that determine the viability and efficiency of any CWWS deployment. Sufficient wind and proximity to an abundant saltwater source are vital. When site



evaluation takes place, these two variables must be closely examined to ensure that wind and water resources will remain abundant throughout the entire project’s lifespan. Turbine spacing and setback distances guidelines as specified in Section 2.1 must be adhered to. Both federal and state marine protected areas should be avoided if at all possible; acquiring permits for these areas is often difficult and time consuming (further discussed below). One of CWWS’s most appealing applications is during emergency/disaster situations. When deploying in response to disasters such as hurricanes, earthquakes, etc., it is important to select sites that have not been structurally compromised by the disaster, and locations that are not especially prone to damage in the event that disaster prolongs or worsens. A more detailed description of the site selection process can be found above in Section 2.1.

### 2.2.2.2 Permitting (1-3 weeks)

Since CWWS requires a significant water source, the most viable and long term options would be on the coast (although brackish water in inland areas could be used as well). With the prime deployment areas being on the coast, permitting can be extensive and subject to many restrictions. As mentioned earlier, it is important to avoid both federal and state marine protected areas (MPA’s). Not only would deploying CWWS in an MPA pose potential threat to marine wildlife, it would also require specific permission from the specific body of government. Requesting permission to develop even a temporary structure in these areas is not easy. The following permitting process is specific to California. **Note that state, county, and city governments may have varying permitting processes and requirements.** The California Coastal Commission (CCC) is the statewide agency that is primarily responsible for granting permit request for coastal development. According to the CCC, there are five general steps to follow when applying for a permit in California for coastal development:

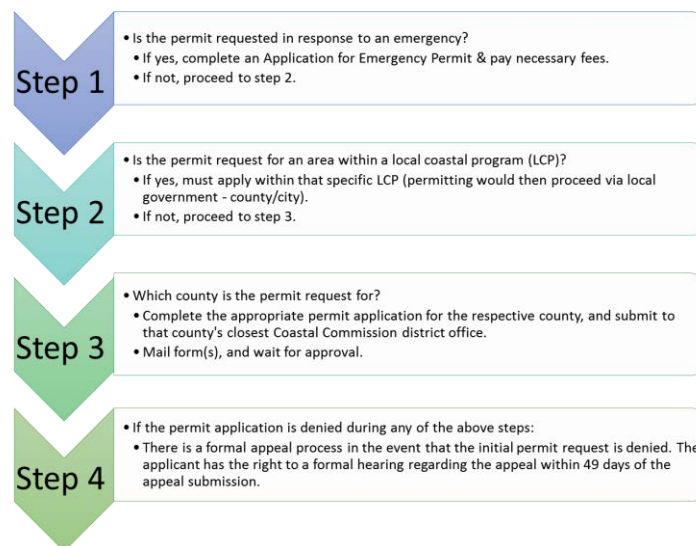

**Figure 2.3: Steps to coastal development permitting process.**

Our time estimates for permitting in California through the CCC are approximately 1 week when requesting an emergency permit, and upwards of 2-3 weeks for non-emergency permits. When requesting a permit through a Local Coastal Program (LCP), time may be longer depending on the local government.

This permitting process is what would be followed for our case study of Cambria, California.

As mentioned above, the permitting for any CWWS deployment will vary dramatically depending on the location. Various cities, counties, and states all have specific permitting processes and procedure. CWWS's permitting specialists are specifically tasked with understanding and navigating the permitting process for the site chosen for deployment.

#### **2.2.2.3 Installation & Testing (4-7 days)**

Installation of the turbine and desalination unit is a multi-step process that takes roughly 5-7 days. After site evaluation/selection and permitting have taken place, the installation can begin taking place. The necessary steps before CWWS can be fully operational are as follows:

1. Concrete piles must be poured and allowed to dry. Individual slabs must be poured for the legs of the turbine tower, as well as a larger foundation for the desalination unit to be mounted onto. (1-2 days)
2. The tower itself must then be assembled. The disassembled tower is brought in via truck, and is mounted to the concrete piles. Testing of structural integrity will take place here. (0.5 days)
3. The turbine unit must then be brought in via truck, and mounted by boom truck onto the tower.
4. Note that the turbine's blades are not yet attached at this stage. Once properly mounted, the blades can be fixed to the turbine. (0.5-1 days)
5. The desalination units are then connected to the turbine for power and a salt/brackish water source. Fencing must also be delivered and constructed to enclose the site. (1 day)
6. Testing must take place to ensure proper and safe operation of both the turbine and desalination units. (1-2 days)

#### **2.2.2.4 Overall Project Lifespan (contract specific)**

Depending on the specific application of the deployment (i.e. immediate disaster relief, long-term drought relief, etc.), the contract for service(s) will vary. Some deployments may be several years, while others may only last as little as a few months. Depending on the type of permit acquired, time limitations may be in place requiring permit renewal in order to meet contract demands. In the event that a permit renewal cannot be granted, the deployment may need to be moved to a different location nearby (if a new permit can be acquired) or the project/contract may need to be terminated indefinitely until further options are made available.

#### **2.2.2.5 Removal (1-2 days)**

The tear down requires that the turbine, tower, and desalination unit are packed and transported properly so that they can be rapidly deployed to another location when necessary. The turbine blades, turbine housing, and desalination unit are the first to be removed from the site. Afterwards, the tower will be disassembled. All of the equipment will undergo inspection prior to being reloaded onto the containers so that any damage/wear and tear are documented and can be repaired before the next deployment.

#### **2.2.2.6 Land Reclamation (1-3 days)**

It is important for any CWWS deployment to have minimal impact on the surrounding environment. After tear down, the land will be reclaimed by removing any poured concrete and re-filling the holes with sand and/or soil. Additionally, any temporary piping will be removed. Depending on the specific location, this can take as little as 1 day.

### **2.2.3 Installation and Maintenance Strategy**

Installation of the turbines and desalination unit will be done via the use of boom trucks. The turbine will be broken down into parts and stored in standard 40 ft. shipping containers. It is estimated that 1 turbine and 3 desalination units can be broken down and split into three 40-foot containers. A simple boom truck can be used to install the turbine over the course of 4-7 days. Thus the turbine and desalination units can be trucked in, assembled, and installed with relative ease.

Concrete will be poured to form pile foundations that ensure the stability of the base of the tower. These concrete footings fill a hole that will be three feet deep and two feet in diameter. Each of the three footings on the turbine will then bolt on to these concrete pads. Depending on the site itself, a concrete slab can be poured to create a solid level surface. However, the tripod design of the turbine would largely make this unnecessary. A 48-hour period will be needed to allow the concrete to dry fully before turbine installation begins.

After installation, maintenance will follow a strategy based on monitoring and preventative maintenance. The desalination unit and turbine can be monitored remotely by a qualified technician. Local electrical technicians can be contracted to perform routine maintenance. Monthly checks would allow CWWS to maintain a high level of availability and safe operation. Part of this monthly check will include unwinding the turbine if needed as the 56 -100 has a free yaw and the cables can become entwined. A spare pitch system, motors, and electrical control units will be on hand for rapid replacement in the event of failure. A separate turbine unit will be located no more than a day's travel time away for access to spare parts. According to industry advisor Kevin Jackson, this will allow the turbine to maximize availability and make the most of the available wind resource to provide water to the community.

In order to ensure that the turbine is functioning at full capacity, the factory recommended maintenance schedule will be followed (US Windpower). This includes preventative maintenance procedures such as checking fittings, bearings, bolts, lubrication points, and control and electrical systems functionality. This maintenance manual can and will be utilized for all projects.

### **2.2.4 Deployment Reliability and Risk Management**

For the reliability and risk management of each site, certain key areas have been identified and addressed. The risks listed can have a negative impact on the success and operation of a project site. Additionally, the risk of community backlash can end a project prematurely. These risks include the impact on wildlife, state, federal, and locally identified conservation areas, site security, mechanical failure that results in potential injuries, and fire.

The impact on wildlife for the 56 -100 is a key concern for CWWS. Birds are acutely vulnerable to the dangers of wind turbines. Birds can be killed or fatally injured when passing through the turbines, hitting guy wires, or perching atop electrical distribution poles. The threat to bird life is dependent on a number of factors such as migratory patterns and habitat range. The migratory patterns of certain bird species can place them at particular risk since they typically follow wind patterns to conserve energy for long flights. CWWS can and will minimize this risk by researching available bird data as well as addressing the concerns of state and local environmental agencies. Given that CWWS aims to operate on project sites consisting of only a few turbines, the risk to bird life is inherently minimal. No major migratory paths lay near Cambria, CA and impact to marine life will be negligible.

To avoid any negative impact on environmental conservation areas, CWWS will comply with all appropriate regulations. State marine reserves, parks, and conservation areas are identified and are to be avoided by CWWS's brine discharge and seawater extraction lines. Doing so ensures compliance with regulations and decreases the risk to marine wildlife. In Cambria, CA, State Conservation areas do exist north of the proposed project site. This, however, will not impact the viability of CWWSs project.

Site security is important for each project. Vandals may damage or destroy property at a site, thieves may destroy property to steal copper wiring and other valuable goods, and thrill seekers may climb the structures which puts them at risk of injury or death. This risk is not only to the property and functionality of the project site, but also to the individuals themselves. As mentioned in the Project Site Selection and Evaluation section, this risk can be greatly reduced by erecting a security fence around the project site. Local law enforcement agencies will likewise be contacted and made aware of these risks with the hope that they can incorporate routine checks as part of their patrols.

Mechanical failures can also be a risk to the operation of a project site. The blades can fly off creating a hazard. Additionally, electrical fire can be of concern in rare situations (Jackson). The security fence will help prevent people from wandering on to the grounds of the project site and therefore lessen the risk of injury. Additionally, preventive maintenance checks should allow the avoidance of such mechanical failures by ensuring fittings and bolts are secure.

### **3.0 Technical Design**

The test turbine is intended to act as a representative model for the full-scale business product being proposed. To that end, the turbine utilizes similar construction, operation, and aesthetics where feasible; the design of the turbine balances an effort to maximize competition performance while providing a model which integrates into the overall business plan for a large-scale turbine.

The test turbine is a three-blade, upwind, HAWT, which utilizes variable pitch for aerodynamic control. The turbine powers a 3-phase AC generator via direct drive coupling, and generator output is converted to DC power via passive rectification. A microcontroller is used to measure performance, run boost/buck power electronics, provide pitching commands for aerodynamic control, and operate a hybrid aero-electrical braking system. Power is supplied to a 12V battery which, in turn, powers a load which displays turbine power production, and moves water through a simple, closed-loop water filtration system.

### **3.1 Marketing and Performance Requirements**

A great deal of consideration was given to the balance between performing well in the testing portion of this competition and presenting a compelling business plan. In the opinion of this team, the cost and complexity of nanoturbines, such as those in this competition, overshadow the potential power production at this scale. As such, nanoturbines do not currently represent compelling products for any major markets. In light of this, this team has produced a test turbine which is focused primarily on competition performance, and an effort to represent the large-scale business turbine has been made where possible.

#### **3.1.1 Performance Considerations**

The turbine design prioritizes competition performance; all design decisions were made to emphasize power production, low start-up speed, control, survivability, and safety during competition testing. Physical dimensions, material selection, turbine construction, blade design & manufacturing, and

electronics & controls layout all flow from competition testing requirements and team strategies for meeting those requirements.

### **3.1.2 Marketing Considerations**

The test turbine is intended to serve as a functioning representation of the business turbine (USW 56-100). Similarities between the test turbine and the USW 56-100 are the variable pitch control system and the tripod tower. Additionally, the test load performs basic water filtration, which represents the desalination component of the business plan. The turbine and load system have been designed to pay homage to their business plan counterparts, while still affording maximum competition performance and feasibility.

## **3.2 Turbine Design Components**

### **3.2.1 Blades**

Blades provide the motive force for a wind turbine generator. Blades are responsible for converting wind energy into meaningful power. The blades need to be optimized to start the turbine at as low a wind speed as possible to maximize its range of power production. The blades also need to be optimized for top end power production once it has overcome the starting torque. These two parameters are constantly competing with one another making it difficult to achieve both. The blades must also be strong enough to prevent failure and excessive deflection as this can negatively impact the aerodynamic behavior of the turbine. The process described here is an iterative process that is constantly undergoing modifications to find a balance between low speed torque production and top end power production.

#### **3.2.1.1 Blade Features**

Blades were carefully selected to achieve minimal start-up wind speed required, while maximizing run speed and power production; blades designed specifically for a variable pitch approach are used. Because blade design is an iterative process, and because blades can be produced fairly easily, it is likely that new blade versions will continue to be produced up to the competition time in late May.

#### **3.2.1.2 Blade Design Process**

The primary blade design tool used in this process was QBlade, an open source program which integrates XFOIL, XFLR, FAST, and BEM modeling tools into an easy-to-use interface. QBlade allows for custom airfoil design via interpolation between known airfoils, and theoretical testing and analysis can be performed on the designed blades from within the tool. It is also possible to export solid model files from QBlade for further customization. QBlade was developed by TU Berlin and is available online. (QBlade)

The iterative design process for producing a blade is shown in Figure 3.1. Blade design begins with airfoil selection. Airfoils are selected based on parameters of lift and drag. Ideally airfoils will have a high lift to drag ratio at a low operating Reynolds number. Very little data exists for airfoils operating at low Reynolds numbers, forcing us to rely on the XFOIL polar graphs within QBlade to predict airfoil performance.

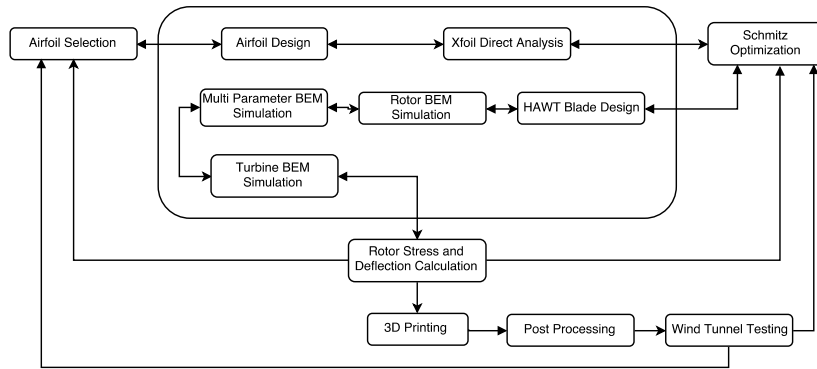

**Figure 3.1: Flow Chart of Blade Design Process**

From the XFOIL polars of Figure 3.2, we select an optimal angle of attack and with the data obtained at this operating point we produce chord and twist schedules. To produce chord and twist schedules we apply the blade element momentum theory described in Wind Energy Explained. For the purposes of our project a Schmitz optimization was used which accounts for an ideal horizontal axis wind turbine with wake rotation. Schmitz optimization equations are applied within a MatLab code to produce chord and twist schedules. Within the Schmitz equations we can alter parameters such as desired tip speed ratio, angle of attack and number of blades.

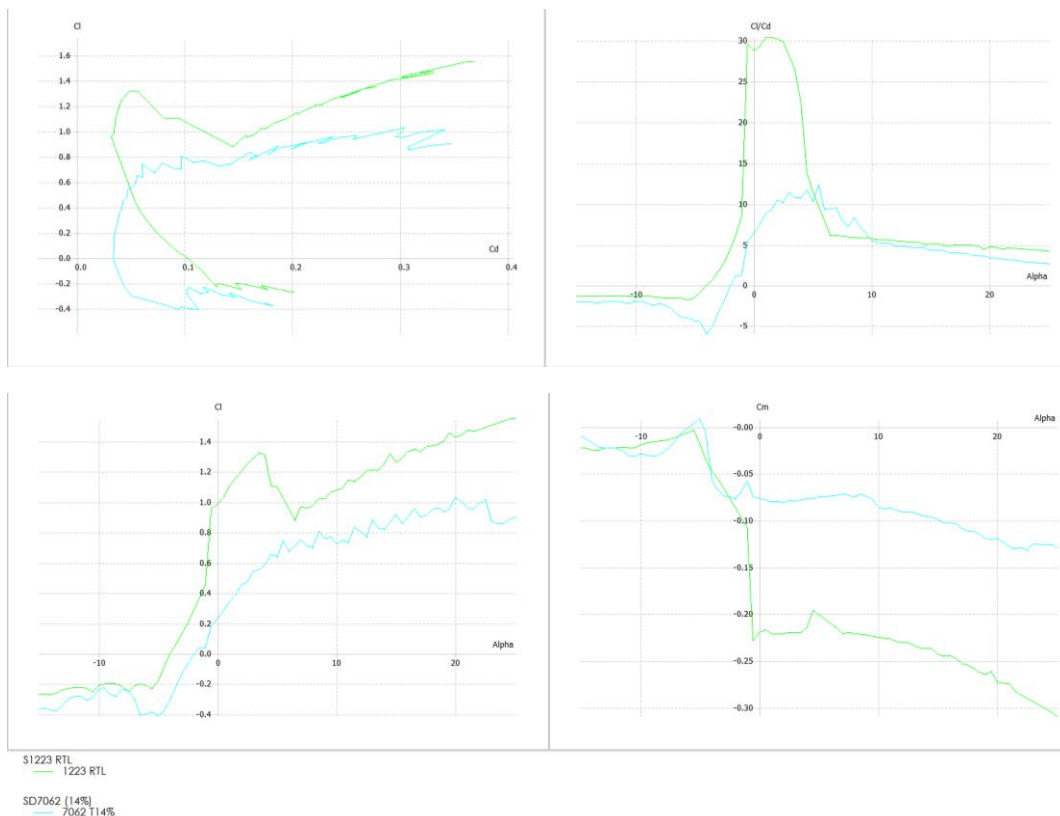
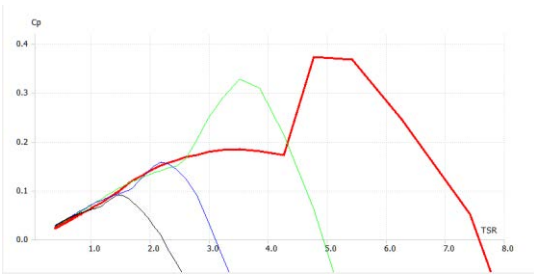

**Figure 3.2: XFOIL Polars for  $Re = 50,000$ . S1223 and SD7062 airfoils in green and blue respectively.**

From the chord and twist schedules obtained, the rotor is simulated with the blade element momentum simulator in QBlade. Operational parameters such as coefficient of power vs tip speed ratio, rotor

starting torque, and pitch schedules can be produced and compared within QBlade. Detailed theoretical analysis is possible, with a wide range of parameters and simulations available. Some key theoretical plots are presented here in the figures below.

The figures below represent actual theoretical analysis performed on the latest iteration of design blades. Figure 3.3 shows that it is possible to obtain a CP of roughly .37 at a TSR of 4.7. Figure 3.4 plots rotor starting torque as a function of wind speed at different pitch angles (each represented by a different color). This plot is useful in determining an acceptable generator starting torque for achieving a low start-up wind speed, and also for establishing the ideal pitch angle for start-up. This plot shows that at a pitch angle of approximately 30° (top line, black) the rotor provides maximum starting torque, and, based on the measure generator starting torque, start-up should be achieved at approximately 5.2m/s assuming no other drive train losses. Figure 3.5 is produced by optimizing TSR from cut-in to rated wind speed and then implementing pitch control above 11m/s. This plot shows that it is theoretically possible to make just over 45W at rated wind speed. Figure 3.6 shows expected rotor RPM at various wind speeds. This plot is useful for predicting our target RPM for maintaining rated power. Figure 3.7 plots the ideal pitch angle associated with holding rated power at various wind speeds. This plot shows that the turbine will be in full run up to rated wind speed, then pitch from 0° to 14° over wind speeds from 11m/s to 15m/s. Because the airfoils used in this blade design process are designed for significantly higher Reynolds numbers than those of this nanoturbine, the results of these analyses are most useful for relative comparisons between potential blade design candidates, and for guiding testing efforts.



**Figure 3.3: Coefficient of Power vs. Tip Speed Ratio**

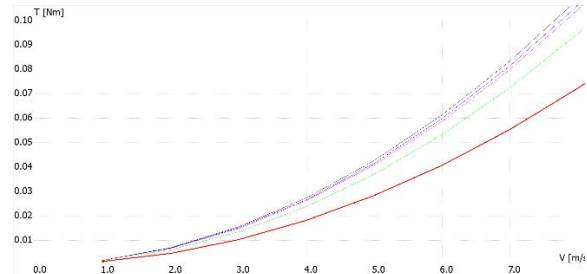

**Figure 3.4: Startup Rotor Torque Production vs. Wind Speed at Various Pitch Angles**

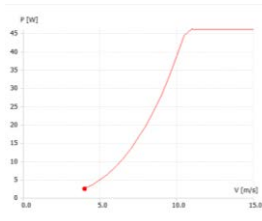

**Figure 3.5: Theoretical power curve for designed blades.**

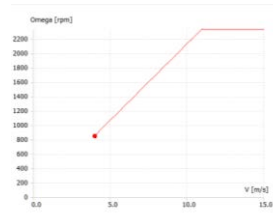

**Figure 3.6: RPM vs Wind Speed for designed blades.**

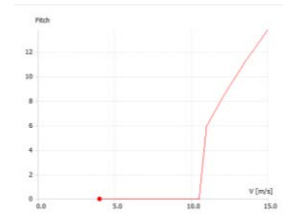

**Figure 3.7: Pitch schedule at various wind speeds.**

### 3.2.2 Blade Loading

The shear stresses on the blade root are modeled to determine whether the blade would withstand the forces experienced during operation, specifically the shear stresses experienced by the blade walls from

the mounting set screw. The centrifugal force increases with rpm so it was determined that the PLA walls of the blade mount needed to be at least 5 layers thick (0.1mm layers) to withstand the anticipated 3000 rpm with sufficient factor of safety. Figure 3.8 shows that the 3mm set screw hole will not fail until beyond 4200 rpm. Bending stress at the root was then calculated to ensure the circular blade mounts are of sufficient diameter to accommodate the forces experienced. It was determined that a 15mm diameter shaft at the blade root was more than capable of accommodating the bending forces experienced by the blade. The maximum overall stress experienced by the blade mount was approximately 2MPa, while PLA has an ultimate tensile strength of 40MPa.

Structural blade loads can also be calculated with the help of QBlade. For a given rotor, the flapwise aerodynamic blade load distribution is determined by QBlade. This data, along with some simple geometric approximations for the airfoil area properties (MIT), can be used to determine bending moment and therefore maximum flexural stress at each section. This is added to the normal stress due to axial centrifugal force. This total stress is plotted in Figure 3.9, for the rated wind speed case. Based on the PLA tensile strength, this yields a factor of safety of >8. A final force calculation predicts the linear force required to resist the natural blade pitching moment. This calculation determined a minimum force required by the linear actuator to operate our pitching mechanism. It was determined that at the worst case scenario for survivability at 17m/s the actuator would need to overcome 9.3N of force.

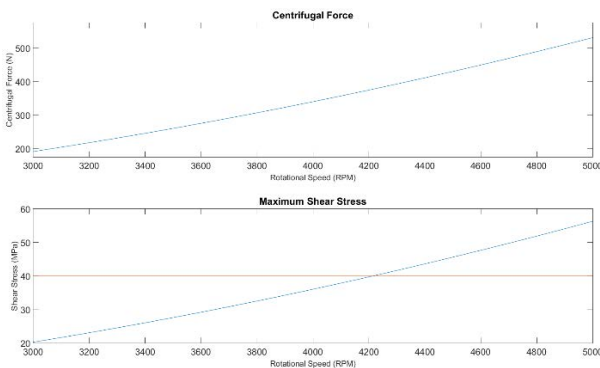

Figure 3.8: Blade pull out force and axial shear stress.

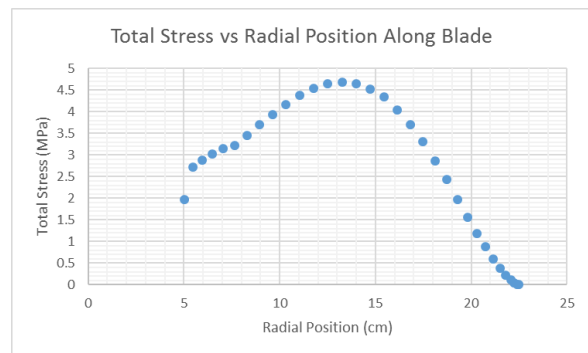

Figure 3.9: Total flapwise stress as a function of radial position for designed blades.

### 3.2.3 Final Blade Selection

Upon arriving at acceptable theoretical outcomes using the process above, a blade design is accepted and moved forward to the production and testing phase. The airfoils used in this blade design process are not specifically designed for the Reynolds number range of nanoturbines, so a significant testing process is necessary to ensure that actual blade performance is comparable to theoretical.

The blades chosen for this turbine are a blend of a Selig/Donovan SD7062 low Reynolds number airfoil and a Richard T. LaSalle modification of the S1223 airfoil, profiles of which are available at [airfoiltools.com](http://airfoiltools.com).

The SD7062 was used for its thick root and related preferential start-up properties; the thicker root also provides a stronger structural element at the root where the blade experiences the most stress. The SD7062 has max thickness 14% at 25.5% chord. This airfoil comprises portions of the first 8 stations of the blade. The S1223 was used for its power production properties at high TSR. The S1223 RTL has a max thickness 13.5% at 19.9% chord. The mid-span of the blade is a graduated interpolation between these two foils. A summary of these blade design specifications can be found in Table 3.1.



**Table 3.1: Summary of final blade design specifications.**

Summary Blade Design Specifications			
Pos (m)	Chord (m)	Twist (deg)	Foil
0.049	0.055	23.4	SD7062 (17%)
0.055	0.052	21.38	SD7062 (14%)
0.06	0.049	19.63	75% SD7062
0.066	0.046	18.11	50% SD7062
0.071	0.044	16.79	25% SD7062
0.104	0.032	11.44	S1223 RTL
0.143	0.024	8.13	S1223 RTL
0.176	0.02	6.41	S1223 RTL
0.198	0.018	5.58	S1223 RTL
0.225	0.016	4.76	S1223 RTL

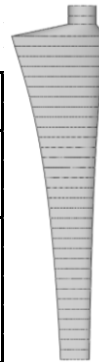

### 3.2.3.1 Blade Manufacturing

Blades were produced with a fused deposition modeling (FDM) 3D printing process, using a MakerBot Replicator. 3D printing of the blades allowed us to quickly and accurately produce the blade models designed in QBlade. The Makerbot used to produce the blades could only print to a minimum thickness of 0.1 mm so the prints lacked resolution at their trailing edges. Following the FDM printing of the blades, they were post processed by hand sanding and coating with epoxy. This filled in any imperfections and also eliminated the striated layer lines left by the 3D printer.

### 3.2.4 Variable Pitch System

The variable pitch system allows the blade angle of attack to be adjusted continuously during turbine operation. A collective pitch system was used, wherein all blades are pitched simultaneously, at the same rate. This system features rotational and fixed components, so minimal inertia, minimal friction, and precise operation are priorities.

The variable pitch system provides critical control functions for the turbine in all phases of operation. This system is able to mimic standard variable speed pitch-control of a modern wind turbine, controlling turbine start-up, run speed, and braking aerodynamically.

#### 3.2.4.1 Variable Pitch Configuration, Components, and Operation

The variable pitch system consists of a central hub, 3 blade mounts and pitch arms, a pitch driver, a push plate, and various bearings and fasteners, as shown in Figure 3.10.

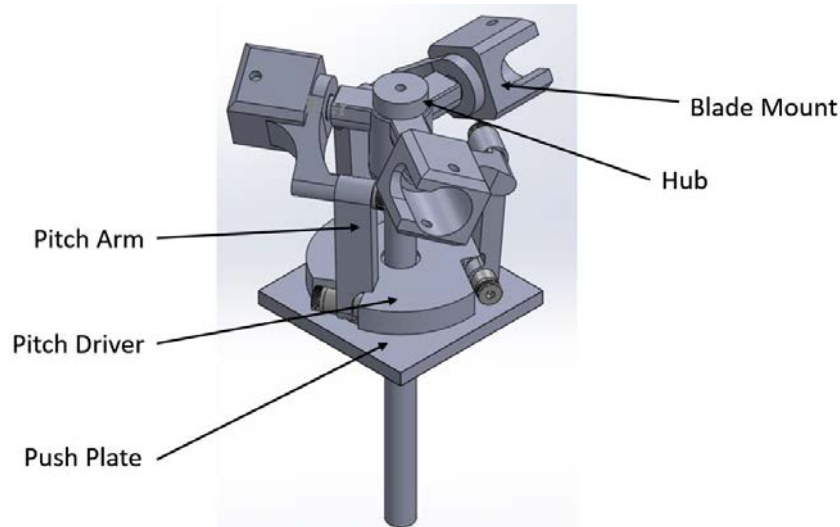

**Figure 3.10: Variable pitch assembly.**

Each of these components, with the exception of the push plate, is fixed to the driveshaft and rotates with it. As the stationary push plate is moved linearly along the shaft, the pitch arms are thrown forward or backward, and the angle of each blade mount is changed due to an eccentric attachment point. A large radial bearing (P/N: F6804ZZ, Flanged, 20mm, ABEC-3) mounted between the push plate and the pitch driver allows the rotational components to rotate while simultaneously being thrown forward or backward, and a linear bearing (P/N LM8UU, 8mm, ABEC-3) between the pitch driver and the shaft reduces friction as the system is actuated. In order to allow for smooth actuation, PTFE sleeve bearings were used at each pitch arm attachment point, and radial bearings were used at the attachment point between each blade mount and the hub.

A Firgelli L12-I linear actuator provides the push and pull needed to vary the pitch. This actuator is connected to the push plate via a small manufacturer supplied bracket, and is anchored at the opposite end to a riser mounted on the turbine bed plate. The actuator is raised off of the bed plate in order to allow for a point of attachment nearer to the shaft, thus minimizing any moment which might lead to binding in the main radial bearing as the actuator pushes or pulls. The actuator uses a 6V supply and is controlled using a servo-style software program run on an Arduino Mega microcontroller. During turbine operation the desired servo angle is commanded, and the actuator moves the push plate to that position and sets the desired blade angle.

#### **3.2.4.2 Variable Pitch Design, Development, and Manufacturing**

The variable pitch system was adapted from a commercial 2-bladed RC helicopter system. This system featured 180° opposed blades and a gimbal-style push plate. A complete redesign of this system incorporating 120° opposed blade mounts and a more constrained push plate, which only allows for linear motion, was performed. Component dimensions were selected to accommodate available shaft material, bearings, and other fastening hardware

After extensive solid modeling of the variable pitch assembly, fabrication was outsourced to an on-campus machinist, who produced components in both CNC and conventional mills and a conventional lathe. A 100% aluminum construction was selected primarily for its light weight, as reducing rotational mass was a priority. The complete assembly (excluding shaft) weighs 56 grams.

### 3.2.4.3 Variable Pitch Loading & FEA

In order to minimize weight in the design of the variable pitch system, components were reduced in cross-section wherever possible. In order to ensure that these components maintained sufficient strength, simple FEA analysis was conducted on components which were identified as having stress concentrations or being generally questionable in cross-sectional size.

One such component was the pitch arm. These components experience rotational, axial, and shear forces, and they have features with very small cross-sections. An FEA was performed to ensure that the lower attachment point would be sufficiently strong to withstand all potential forces. A load of 10 lbf, which exceeds any expected force on the piece, was applied and deformation, stress, and FOS were observed. FOS was found to be 2.78 for the component, and stresses and deformations were found to be under the yield strength and tolerance limits of the piece. Figure 3.11 and Figure 3.12 show the pitch arm FEA results.

FEA analysis was performed on each component of this assembly. In the interest of presenting a succinct report, FEA results for these components have been withheld. FOS for the entire assembly is  $\geq 2.78$ .

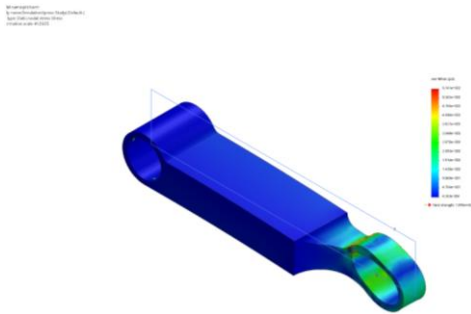

Figure 3.11: Pitch arm stress results.

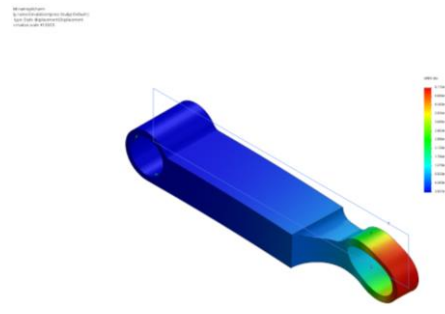

Figure 3.12: Pitch arm displacement results.

### 3.2.5 Turbine Structure

The turbine structure consists of a bed plate, L-bracket motor mount, actuator mounting block, main-bearing riser, variable pitch hub, shaft, and various fasteners. With the exceptions of the shaft and fasteners, the structural components are constructed of 6061 Aluminum alloy. The structure is designed for simplicity and to minimize frictional losses.

#### 3.2.5.1 Structural Components

The open nacelle design allows for ease of access and assembly. A 3" x 7" aluminum bed plate serves as the mounting surface for all components. The bed plate mounts directly to the turbine tower.

The actuator mounting block elevates the actuator to align with a desired attachment point on the variable pitch hub. This piece features a small mounting bracket for actuator attachment.

The main bearing riser elevates a captured radial bearing (P/N: 8600N13, 8mm, ABEC-3) to align with the shaft. A simple block construction which features mounting holes for the bearing and a pass-through to allow linear actuator operation was used.

The generator mount is a machined 90° angle bracket which features mounting holes for the generator. This piece is crucial to shaft alignment, so locator pins were used for precise centerline location. Figure 3.13 shows the location and relationship of each structural component.

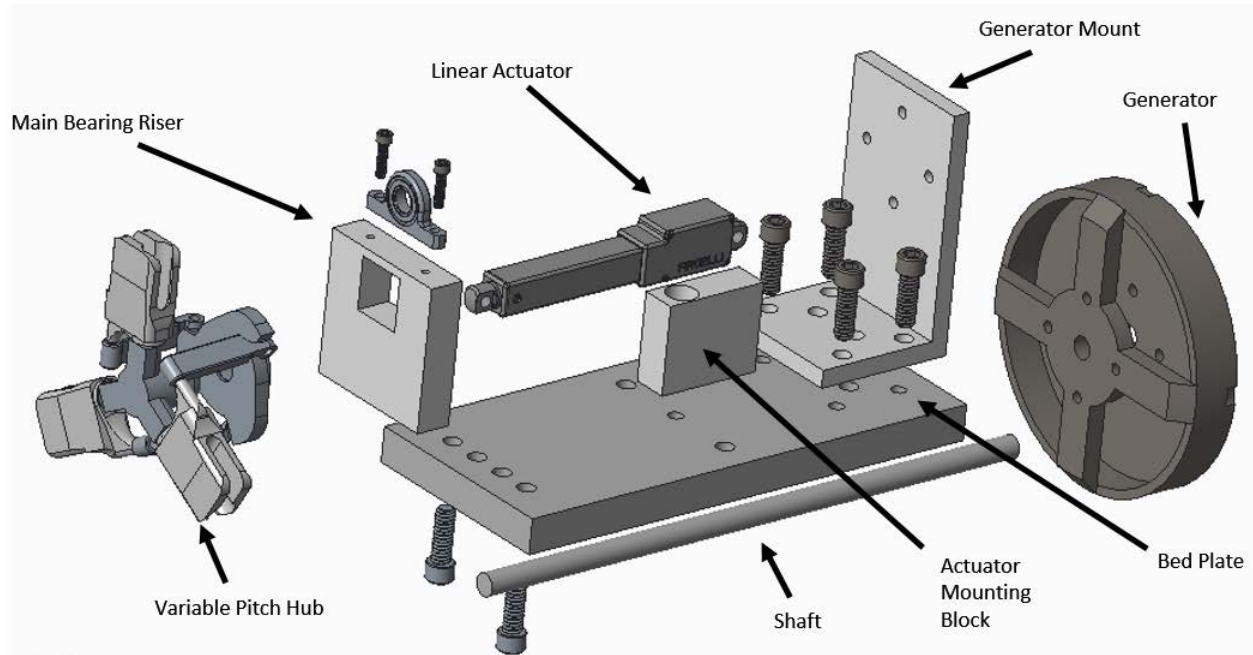

**Figure 3.13: Turbine construction, exploded view.**

### **3.2.6 Turbine Electronics**

Measuring and controlling turbine power output, and performing braking and start-up functions are of primary importance for the electronics system, and because this particular turbine design employs a variable pitch, actuating and controlling blade pitch to meet the power, braking, and start-up requirements aerodynamically was prioritized wherever possible.

#### **3.2.6.1 Generator Selection**

Primary considerations in generator selection were low KV (RPM/volt) and low starting torque. The generator chosen is a DYS BE8108 outrunner, brushless DC motor. The permanent synchronous motor has 36 poles, 100 KV, and an internal resistance of 0.3 Ohms. The starting torque was experimentally found to be 0.04 Nm. Several motors were tested using a student-built dynamometer test bench, and the DYS was chosen for its low KV, moderate starting torque, and low internal resistance.

#### **3.2.6.2 Power Tracking**

The electronics and controls are modeled after a solar panel charge controller. The solar panel charge controller utilizes maximum power point tracking (MPPT) to ensure that the maximum amount of power is being drawn from the system in various lighting conditions. The wind turbine applies this principle, tracking the maximum power point at the changing wind speeds. Tracking the output power and the turbine's RPM, the algorithm adjusts the controller's duty cycle D, ensuring the turbine is properly loaded.

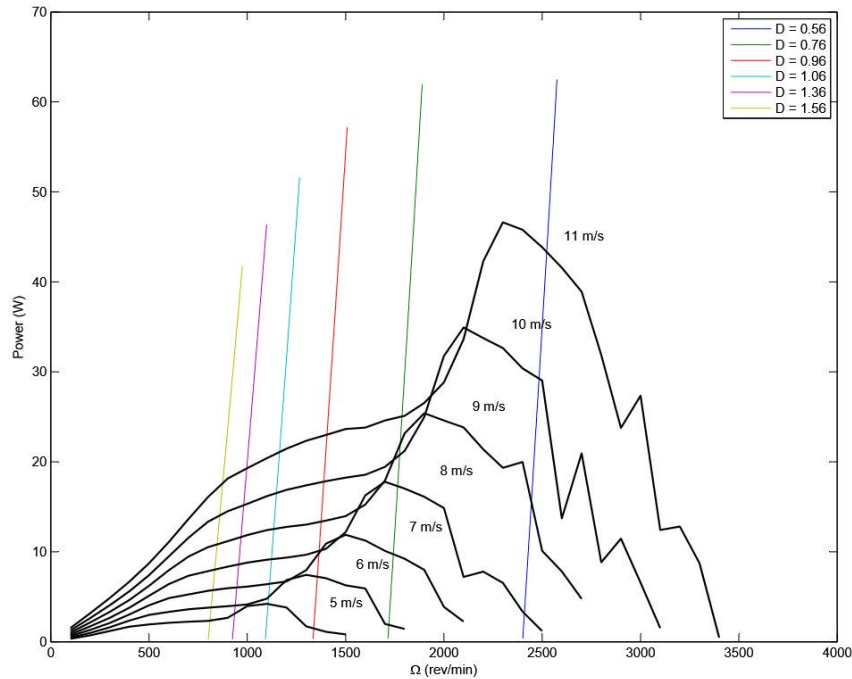

**Figure 3.14: Generator/Load model.**

Figure

Figure 3.14 is a combined generator/load model. The black curves show the expected power at a given RPM for each wind speed, acquired from blade modeling data from QBlade, while the colored lines are the expected power at a given RPM for each duty cycle percentage. The load curves are derived from a simple model of a DC motor consisting of an ideal voltage source with voltage proportional to rpm in series with an armature resistance providing the input voltage to the boost/buck converter. The output voltage of the converter is the input voltage to the battery which is modeled as an internal resistance in series with an ideal voltage source of 12 V. The boost/buck converter is assumed ideal with a voltage gain of  $D$ . The MPPT, see FIGURE below, algorithm will shift from load line to load line seeking the peak power at each curve. This model shows that we will theoretically have a maximum power of 46W at the rated wind speed of 11 m/s.

The buck boost converter consists of a buck converter in series with a boost converter. The overall gain  $V_{out}/V_{in} = D$  of the converter is a product of the two duty cycles as follows:

$$D = \frac{D_{buck}}{(1 - D_{boost})}$$

Duty cycles shown above 1.0 represent the boost side of the control. At the lower and start-up RPM speed it becomes necessary to boost the output voltage of the generator to match the 12V on the load. This allows for the turbine to be as unloaded as possible during its initial phase.

### 3.2.6.3 Electrical Components and Operation

The core of the controller is a synchronous boost/buck converter, utilizing switching MOSFETs to control the output power of the controller. The synchronous converter was chosen in order to limit forward

voltage losses. Passive Schottky diodes are used in the three phase full wave rectifier to convert the three phase AC power into DC power (Dutta).

An Arduino Mega was selected as the microcontroller to implement power electronics and control the turbine. The controller has six timers, 15 PWM output pins, 54 digital pins, and 16 analog pins. The software is a wrapped version of C++. Power is taken from the load and stepped down to 7V to provide power to the microcontroller and linear actuator. The PWM output from the Arduino goes to a MOSFET driver which allows the signal to overcome the gate and drain capacitance as well as provide the inverted synchronous signal. The dead time for the MOSFET driver is approximately 0.5 microseconds. The standard timers for the Arduino can only output PWM signal at a frequency around 1 kHz. A frequency this low would require electrical components to be sized much larger to handle the increasing in current and voltage build up. Modification of a timer became necessary in order to get the switching frequency up to the desired 50 kHz (Shiriff).

The four major runtime metrics taken are turbine RPM, converter input voltage, output voltage and output current. RPM is monitored by frequency of one of the AC line voltages upstream of the rectifier. An opto-isolater keeps the higher voltage separated from the microcontroller and converts the sinusoidal frequency into a square wave. RPM is then calculated from frequency based on the number of poles of the motor (“Synchronous Speed”).

$$\text{RPM} = 60 * \text{freq} * \frac{2}{36}$$

For simplicity, a shunt resistor was chosen over a hall-effect current sensor to measure output current from the converter. Voltage dividers are used to step measured voltages down to levels tolerated by the Arduino.

A dynamic braking system is implemented across the output of the rectifier to provide an additional failsafe brake during the braking test. A power resistor in series with a relay comprises of the brake. The relay is held open by the microcontroller during operation and is closed upon detection of load disconnect.

The microcontroller outputs two PWM signals for the each MOSFET driver. The algorithm climbs the peak of each power curve, comparing the power at the previous time step to the current time step until the current time step is not making more power than the previous one. The resulting voltage will oscillate around the top of the peak which will be smoothed by use of capacitors (Dutta).

The power outputs to a battery load rated for 12V. The electronics uses the battery output voltage to acquire a set point to which the turbine voltage output will be boost or bucked to. Additionally, the battery will provide the initial power source for the control electronics during startup. Power will shift to being drawn from the turbine once the turbine engages into its operational mode.

A complete turbine electronics schematic can be found in Appendix D.

#### **3.2.6.4 Control System & Software Algorithm**

The control software has four modes: boost, buck, rated power, and braking. Boost will occur during start up. During boost mode, the buck MOSFET is fully closed,  $D_{\text{buck}} = 100\%$ , to allow full power through it and the boost MOSFET duty cycle will decrease from 100% in order to track MPP while input voltage is less than 12 V. In addition, during the boost mode, the turbine will pitch the blades from their initial

start-up position, set at an experimentally determined schedule, to the full speed run position. Once the converter input voltage is 12V, the mode switches to buck.

During buck mode, the MOSFET for the boost is held open,  $D_{\text{boost}} = 0\%$ , and the buck duty cycle will vary to control RPM and track MPP. Once the turbine hits rated power, the software will hold the duty cycle constant while the blades begin to pitch into of the wind. Utilizing PID control, with rated power as the set point, the blades will begin to pitch to maintain a constant power output at higher wind speeds. The approximate pitch schedule is shown in Figure 3.7.

Finally, during braking the blades will pitch fully into the wind and upon completion of this, the dynamic brake will be engaged to ensure maximum stop. Braking will be initiated when the output power is equal to zero. When the load is disconnected, the current draw from the load will be nothing, signaling the Arduino to begin the brake condition. Additionally, an emergency switch will be wired into the Arduino. When the normally closed switch is opened, the signal drops, causing an interrupt routine to begin the brake condition.

A complete turbine control scheme can be found in Appendix E.

### **3.2.7 Turbine Testing**

At the time of this report the team is entering the testing and optimization phase of the design process. More extensive testing is planned leading up to the May competition, including full control system testing.

All testing was performed in Cal Maritime's student-built wind tunnel which was initially constructed for testing before the 2015 competition. This wind tunnel was significantly upgraded by this year's team, with upgrades which include a larger motor achieving wind speeds in excess of 15m/s, an intake flow straightener, and various structural and safety improvements.

#### **3.2.7.1 Start-up Wind Speed Testing**

Because a low start-up wind speed is desirable for competition performance and as a measure of drive-train efficiency, initial testing was focused on establishing and improving this parameter. A simple testing process of setting the blades to a start-up position and incrementing wind speed until rotation was observed was used.

Initially, a start-up wind speed of 8.5m/s was achieved. Several areas of high friction and binding were identified and addressed, and a second test achieved a start-up wind speed of 7 m/s. This prompted a second prototype iteration, now complete. Subsequent tests have yielded start-up speeds as low as 5.0 m/s, though this result has not been consistently repeatable. Typical start-up wind speed is currently 5.5 - 6.1m/s Desired start-up will be accomplished through blade optimization for greater starting torque.

#### **3.2.7.2 Operation and Variable Pitch Testing**

The turbine was tested at wind speeds from 0-11 m/s, and the relationship between blade angle and RPM was observed continuously. Predictable and repeatable control of turbine RPM through varying pitch was observed. An observed turbine RPM range of roughly 250 to 3500 was observed over the range of wind speeds and various pitch angles. Additionally, aerodynamic braking was demonstrated repeatedly. These tests indicate that the turbine operation will be capable of being controlled aerodynamically, and this represents a significant success for the design team in terms of the function and efficacy of the variable pitch system.

### 3.2.7.3 Power Production Testing

Power production was tested using a simple circuit with a variable resistor bank connected to the rectified turbine generator output acting as a load; voltage and current through the resistor bank were continuously monitored. The turbine was set in the run position at various wind speeds, and the electrical load was varied using the resistor bank. By adjusting the load on the turbine in conjunction with changes in wind speed, a maximum power point tracking system (MPPT) was roughly approximated. Testing resulted in a maximum power point of 29.95 W at 11.1 m/s and 2200 RPM, which results in a CP of roughly .24 and a TSR of 4.7. Power curves produced during this test are found in Figure 3.15 below.

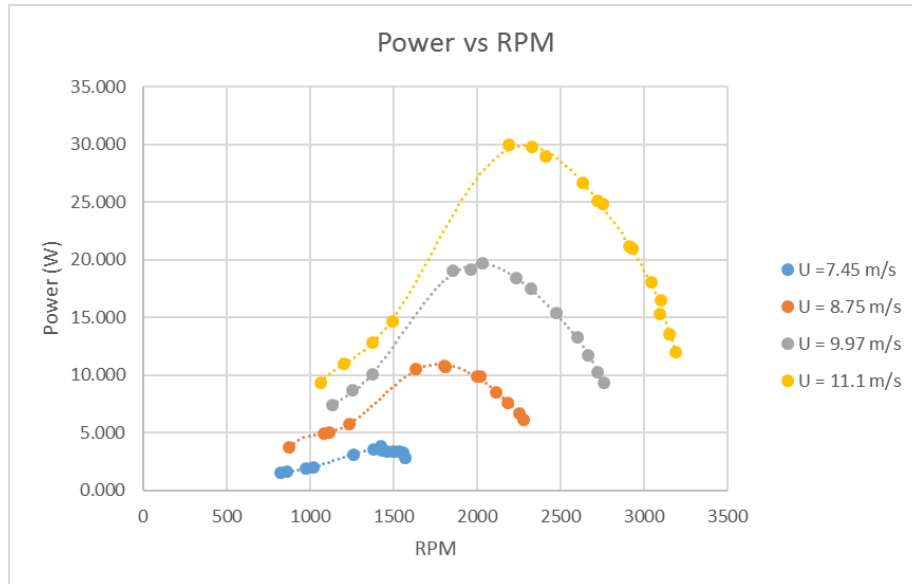

Figure 3.15: Turbine power curves, obtained through testing.

### 3.3 Load Design Components

The load is designed to meet competition requirements for displaying power production while representing the water purification aspect of the business plan. In this way, the load is divided into two distinct functional units: water purification and power monitoring.

#### 3.3.1 Power Monitoring System

The power monitoring system consists uses an Arduino microcontroller with an adjusted sample rate, augmented data storage, and creative data communication software to act as a DAQ for voltage sampling and power calculations. Data is then transmitted to a Raspberry Pi which displays the power production data via LCD screen. This system is still very much under development at the writing of this report, and a prototype has not yet been produced.

##### 3.3.1.1 Power Monitoring Components and Operation

The power monitoring system senses voltage at a point just downstream of the PCC. Using a voltage divider, the relatively high voltage produced by the turbine is divided down to a 0-5V range acceptable for the Arduino. At the same point, a shunt resistor is used to measure amperage. These values are sampled by the Arduino at a fixed rate, and power is calculated using Ohm's law. A conceptual component diagram is shown below in Figure 3.16



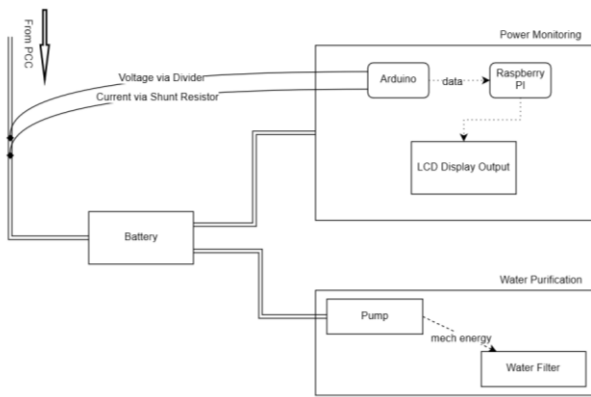

**Figure 3.16: Load power monitoring system design.**



**Figure 3.17: Prototype water purification system.**

### 3.3.2 Water Purification System

An electrical load was made to demonstrate the process of water purification. The load's purpose is to visually demonstrate the idea of water purification with power available from the wind turbine and battery. How much power the load can draw is based mainly off the capacity of the battery and secondarily on how much power the turbine is producing. Aesthetics is the main driving force behind the load design. Another characteristic of the load is that it helps illustrate the power being produced by the turbine.

The load demonstration is made of two tanks: a clean water tank and a dirty water tank. Initially the clean water tank starts out empty and the dirty tank starts out with dirty water. When the demonstration is turned on water is pumped from the dirty tank through a filter and into the clean water tank. The clean water tank is filled with a water faucet to further the analogy between the demonstration and the reverse osmosis water purification in the business plan.

The system uses a double-diaphragm pump with a power consumption of 36W. The filter that is being used is a 5micron inline water filter. The tank on the left is the dirty water tank and the tank on the right is the clean water tank. When the clean tank is full it overflows back to the dirty water side to allow the system to continuously run. As the demonstration continues to run, both tanks will have clean water. The dirty water tank is 9 x 9 x 5.5in and the clean water tank is 3.5 x 3.5 x 11in. These dimensions were selected to ensure overflow from the clean to dirty tank for the desired continuous loop operation needed for display. The tank is constructed with two sides and the bottom made from wood and the two remaining sides acrylic. A rudimentary prototype of the water purification system is shown above in Figure 3.17.

## Appendix A Perceptual Map

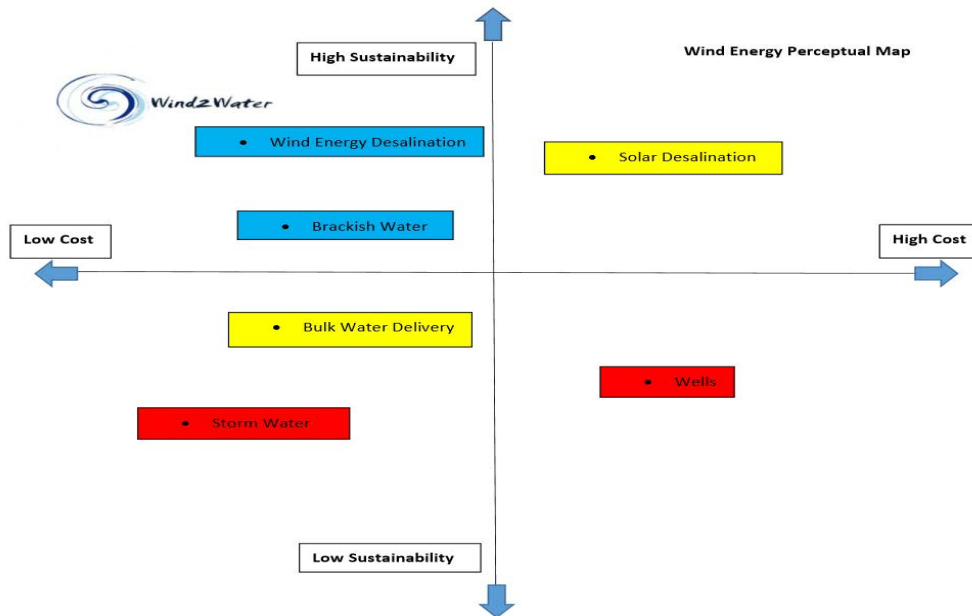

## Appendix B Five Forces Analysis

Criteria	Industry Characteristics
<b>Suppliers (Moderate)</b>	<ul style="list-style-type: none"> <li>→ Only a few of suppliers of water with high switching costs.</li> <li>→ The water user rates and the standard daily rate service charges need to be approved by the city council.</li> </ul>
<b>Buyers (Low)</b>	<ul style="list-style-type: none"> <li>→ Switching costs to buyers are significant.</li> <li>→ There are many buyers (including all the residents living in the city) who are willing to buy a small quantity.</li> <li>→ Water commodity is able to be sustained and conserved for long durations.</li> </ul>
<b>Substitutes (Very Low)</b>	<ul style="list-style-type: none"> <li>→ Ineffective substitutes, not cost effective substitutes.</li> <li>→ Shrinkage of availability of fresh water due to severe drought.</li> <li>→ Brackish water desalination is an alternative to conventional desalination.</li> </ul>
<b>Barriers to Entry (Strong)</b>	<ul style="list-style-type: none"> <li>→ There are high barriers to entry because of the substantial environmental requirement (CEQA)</li> <li>→ Cost of entering into a fixed and tight market.</li> </ul>
<b>Rivalry (Moderate)</b>	<ul style="list-style-type: none"> <li>→ Very limited number of players to supply water.</li> <li>→ Little product differentiation for consumption (water needs to meet certain quality standards to be drinkable as per regulation).</li> <li>→ Growth prospect vary by technology (solar vs. wind vs. diesel vs. conventional).</li> </ul>

## Appendix C Financial Statements

Wind2Water Projected Revenue		
Contract Term	5	
Month Charge		\$ 95,000
Yearly Revenue		\$ 1,140,000
Total Contract Revenue (Gross)		\$ 5,700,000
Total Costs over Contract	\$ 5,412,589	
Total Net Income		\$ 287,411

Wind 2 Water Income Statement For the Period Ending 2017		
Sales Revenue		\$ 1,140,000
Origination Fee		\$ 50,000
Capital Expense*	\$ 1,956,000	
Operating Expense		
Wind Monitoring expense	\$ 3,000	
Equipment Maintenance Expense	\$ 66,000	
Transportation Expense	\$ 10,000	
Salaries	\$ 200,000	
Depreciation expense	\$ 10,000	
Installation Expense**	\$ 35,000	
Other Expense***	\$ 25,000	
Interest Expense	\$ 372,143	\$ 2,677,143
Income before income tax		-\$ 1,487,143
Income tax expense		\$ 25,743
Net Income		<u>-\$ 1,512,886</u>

\* Includes the one time purchase of Turbines and R/O unit  
\*\* One time costs of installation and construction of perimeter barrier  
\*\*\* Includes Rent, supplies and miscellaneous expenses

Wind2Water Income Statement For the Period Ending 2018		
Sales Revenue		\$ 1,140,000
Origination Fee		-
Capital Expense	-	
Operating Expense		
Wind monitoring expense	\$ 3,000	
Equipment Maintenance	\$ 69,300	
Transportation Expense		
Salaries	\$ 200,000	
Depreciation expense	\$ 10,000	
Installation expense	-	
Other expense	\$ 25,000	
Interest Expense	\$ 372,143	\$ 679,443
Income before income tax		\$ 460,557
Income tax expense		\$ 19,866
Net Income		<u>\$ 440,691</u>

Wind2Water Balance Sheet For the Period Ending 2017	
<b>Assets</b>	
<b>Current assets</b>	
Cash	\$ 131,114
Accounts receivable	
inventory	\$100,000
Prepaid expenses	
Total Current Assets	\$ 231,114
<b>Property,Plant, Equipment</b>	
Turbines	\$ 300,000
Desalination Units	\$ 1,656,000
Accumulated Depreciation	-\$ 146,700
Total Assets	\$ 2,040,414
<b>Liabilities</b>	
<b>Current liabilities</b>	
Notes payable	\$372,143.49
Unearned Revenue	
<b>Long term liabilities</b>	
Notes Payable	\$7,027,561.35
Total Liabilities	<u>\$7,399,704.84</u>

Wind2Water Balance Sheet For the Period Ending 2018	
<b>Assets</b>	
<b>Current assets</b>	
Cash	\$ 567,735
Accounts receivable	\$ -
inventory	\$100,000
Prepaid expenses	
Total Current Assets	\$ 667,735
<b>Property,Plant, Equipment</b>	
Turbines	\$ 300,000
Desalination Units	\$ 1,656,000
Accumulated Depreciation	-\$ 146,700
Total Assets	\$ 2,477,035
<b>Liabilities</b>	
<b>Current liabilities</b>	
Notes payable	\$372,143.49
Unearned Revenue	
<b>Long term liabilities</b>	
Notes Payable	\$6,655,417.86
Total Liabilities	<u>\$7,027,561.35</u>

Loan Calculation and Ammortization	
Intest Rate Per Year	7%
Principle	\$4,000,000
Term	20
Monty Loan Payment	-\$31,011.96
Interest due per month	-\$22,920.67
Total Intest Acrewed	-\$3,399,704.84
Total Outstanding Liabilities	<u>\$7,399,704.84</u>
Yearly Payments	\$372,143.49

## Appendix D Turbine Electrical Model

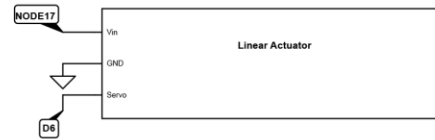
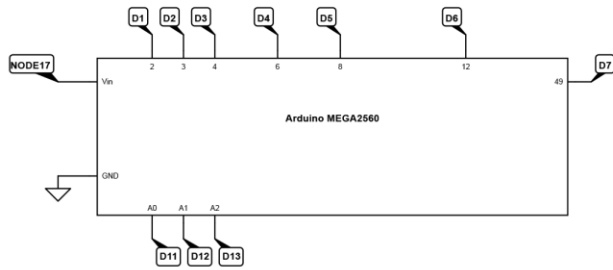

D1	$d_{Buck}$
D2	$d_{Boost}$
D3	$sd_{FETDriver}$
D4	$brake$
D5	$optoPower$
D6	$Pitch$
D7	$Freq$
D11	$V_{in}$
D12	$V_{out}$
D13	$I_{out}$

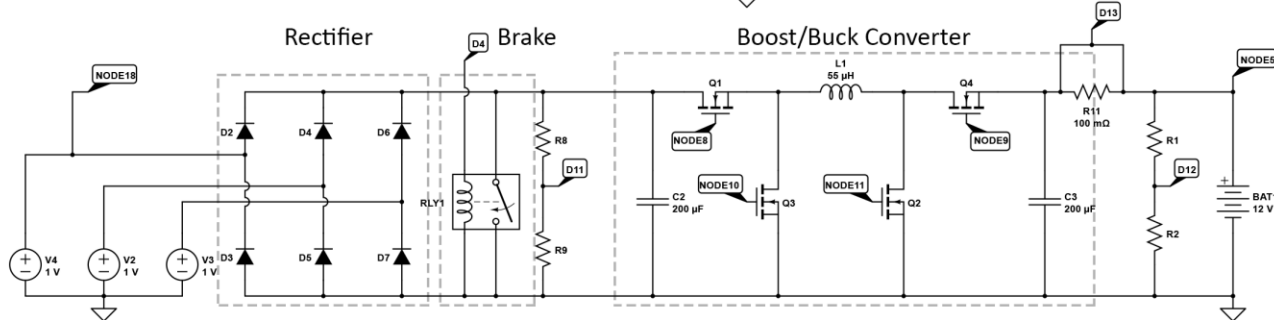
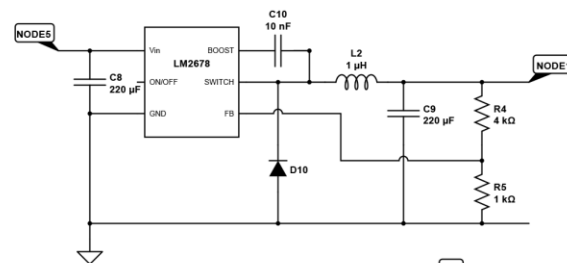
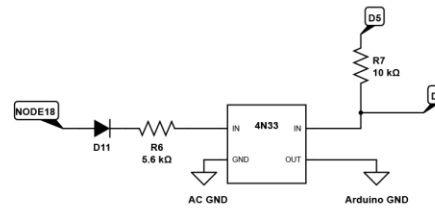
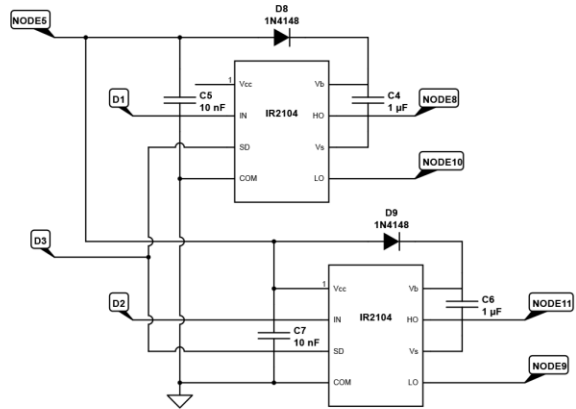

## Appendix E Turbine Control Scheme

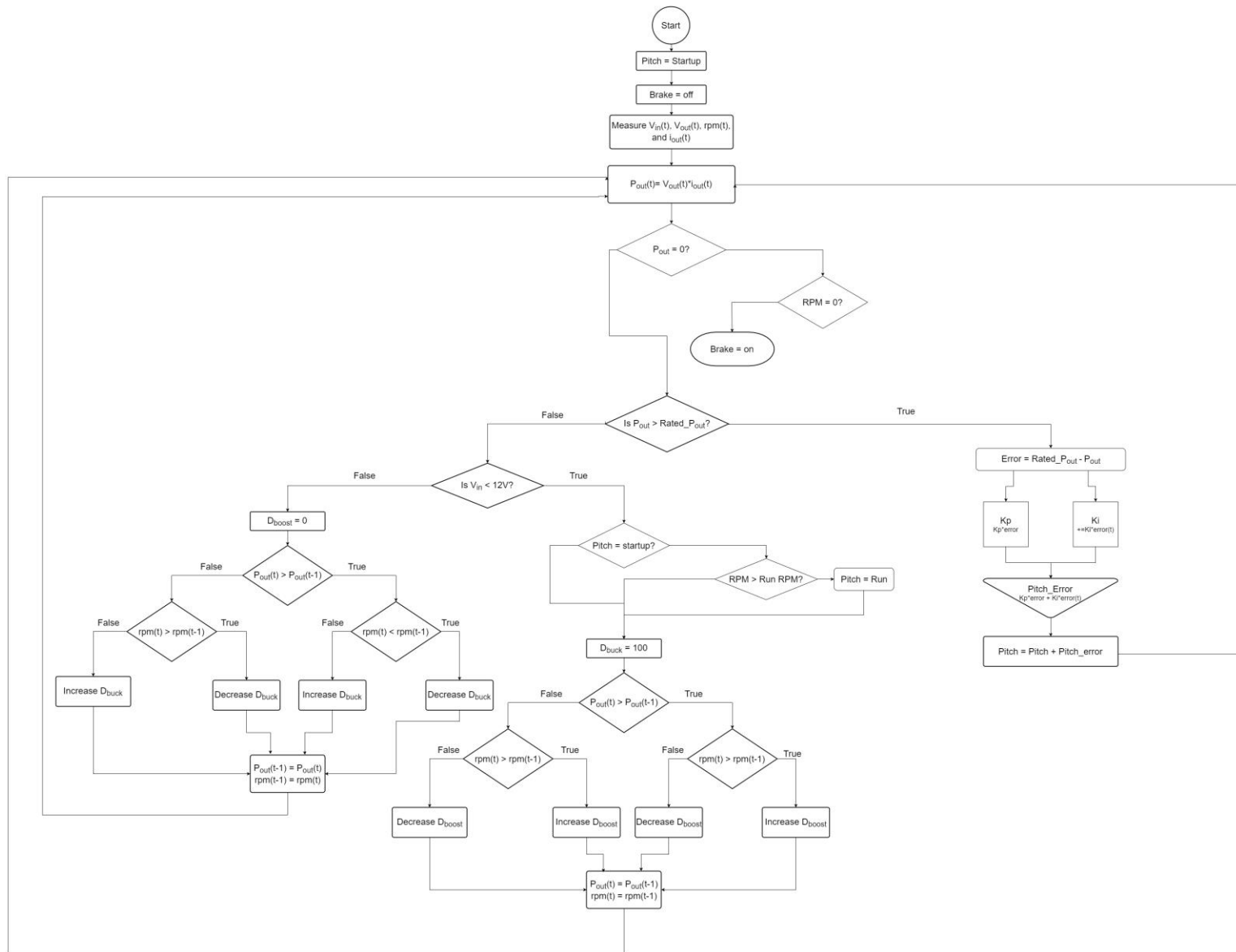

## Works Cited

### Business References

- "Assocenergy." *Assocenergy*. N.p., n.d. Web. 30 Apr. 2016. <<http://www.assocenergy.com/>>.
- Bein, Robert, and William Frost. *Final Environmental Impact Report Cambria Desalination Facility* (n.d.): n. pag. Web. 29 Apr. 2016. <[http://www.cambriacsd.org/Library/PDFs/PROJECTS/Desalination/1994%20Desal%20EIR/1994.12\\_Desalination\\_Final\\_EIR\\_Sect\\_03\\_Proj\\_Location\\_Background.pdf](http://www.cambriacsd.org/Library/PDFs/PROJECTS/Desalination/1994%20Desal%20EIR/1994.12_Desalination_Final_EIR_Sect_03_Proj_Location_Background.pdf)>.
- East Bay Municipal Utility District. "History of EBMUD." *East Bay Municipal Utility District* :: N.p., n.d. Web. 30 Apr. 2016. <<http://www.ebmud.com/about-us/who-we-are/mission-and-history/>>.
- Keene, Charles F. *Water Desalination Findings and Recommendations*. Sacramento: State of California, 2003. Oct. 2003. Web. <<http://www.water.ca.gov/desalination/docs/Findings-Recommendations.pdf>>.
- McGovert, Morgan. "PowerWorks Wind Turbines." (n.d.): n. pag. *PowerWorks*. Web. 30 Apr. 2016. <<http://www.powerworks.com/Documents/PowerWorks%20100%20kW%20brochure.pdf>>.
- Medina, Jennifer. "With Dry Taps and Toilets, California Drought Turns Desperate." *The New York Times*. The New York Times, 02 Oct. 2014. Web. 01 May 2016. <[http://www.nytimes.com/2014/10/03/us/california-drought-tulare-county.html?\\_r=0](http://www.nytimes.com/2014/10/03/us/california-drought-tulare-county.html?_r=0)>.
- Nagourney, Adam, and Ian Lovett. "Severe Drought Has U.S. West Fearing Worst." *The New York Times*. The New York Times, 01 Feb. 2014. Web. 30 Apr. 2016. <[http://www.nytimes.com/2014/02/02/us/severe-drought-has-us-west-fearing-worst.html?\\_r=0](http://www.nytimes.com/2014/02/02/us/severe-drought-has-us-west-fearing-worst.html?_r=0)>.
- National Drought Mitigation Center, The. "U.S. Drought Monitor." *United States Drought Monitor Home State Drought Monitor*. The National Drought Mitigation Center, n.d. Web. 30 Apr. 2016. <<http://droughtmonitor.unl.edu/Home/StateDroughtMonitor.aspx?CA>>.
- Sandrik, Sara. "Drought Solution Possibly Discovered in California." *6abc Philadelphia*. N.p., 13 Feb. 2015. Web. 30 Apr. 2016. <[http://6abc.com/news/drought-solution-possibly-discovered-in-california/516264/\[13\]](http://6abc.com/news/drought-solution-possibly-discovered-in-california/516264/[13])>.
- United States Geological Survey. "California Drought Information." *California Water Science Center*. United States Geological Survey, 11 Mar. 2016. Web. 30 Apr. 2016. <<http://ca.water.usgs.gov/data/drought/index.html>>.
- United States Geological Survey. "California Drought, Visualized with Open Data." *United States Geological Survey*. N.p., 17 May 2015. Web. 29 Apr. 2016. <[http://cida.usgs.gov/ca\\_drought/](http://cida.usgs.gov/ca_drought/)>.
- United States Geological Survey. "California Water Use 2010." *California Water Science Center*. United States Geological Survey, n.d. Web. <[http://ca.water.usgs.gov/water\\_use/2010-california-water-use.html](http://ca.water.usgs.gov/water_use/2010-california-water-use.html)>.
- U.S. Census / Cambria Community Service District

Wind4Water. "About Us." *Wind4Water*. N.p., 04 June 2013. Web. 01 May 2016. <<http://www.wind4water.com/about-us/>>.

### Deployment References

California Coastal Commission (n.d.). Retrieved April 23, 2016, from <http://www.coastal.ca.gov/>

Center for Disease Control and Prevention (n.d.). Noise and Hearing Loss Prevention. Retrieved from <http://www.cdc.gov/niosh/topics/noise/>

Big Brand Water Filter Inc. (n.d.). SeaPro-5000. Retrieved from <http://www.bigbrandwater.com/seapro50000.html>

Department of Fish and Wildlife (n.d.). Central Coast Project: Regional Stakeholders Group. Retrieved from [http://www.dfg.ca.gov/marine/mpa/centralcoast\\_rsg.asp](http://www.dfg.ca.gov/marine/mpa/centralcoast_rsg.asp)

Federal Aviation Administration (n.d.). Obstruction Evaluation/Airport Airspace Analysis. Retrieved from <https://oeaaa.faa.gov/oeaaa/external/portal.jsp>

Jackson, Kevin. Pacificos engineering Personal Interview. April 20, 2016.

National Wind Watch (n.d.). FAQ-Size. Retrieved from <https://www.wind-watch.org/faq-size.php>

Storz, Ryan. Professor California Maritime Academy Personal Interview. April 24, 2016.

USW 100 KW Field Manual (1992). 56- 100 Field Maintenance Manual Number 113119.

WindExchange (n.d.). Residential-scale 30-meter wind maps. Department of Energy. Retrieved from [http://apps2.eere.energy.gov/wind/windexchange/windmaps/residential\\_scale.asp](http://apps2.eere.energy.gov/wind/windexchange/windmaps/residential_scale.asp)

### Engineering References

"The Arduino DAQ Chronicles - Measuring Stuff." The Arduino DAQ Chronicles - Measuring Stuff. N.p., n.d. Web. 01 Feb. 2016. <<https://sites.google.com/site/measuringstuff/the-arduino>>.

*Seawater Desalination Costs*. Tech. Alexandria, VA: WateReuse Association, n.d. Web. 15 Apr. 2016. <[watereuse.org](http://watereuse.org)>.

Afrotechmods. "Switch Mode Power Supply Tutorial: DC-DC Buck Converters." *YouTube*. YouTube, 18 Aug. 2014. Web. 30 Apr. 2016.

Ant. "C2000 Solar MPPT Tutorial Covering the Electronics & C Code." *CoderTronics*. AnkerMedia, 02 July 2014. Web. 01 May 2016.

"Arduino Data Logger or Data Acquisition System to Monitor a Wind Turbine." *Wind & Wet*. Amazon, 2016. Web. 01 May 2016.

Bennett, Peter. "Using a 12V Battery While Simultaneously Charging via Solar Panel." *Electrical Engineering*. StackExchange, 15 Apr. 13. Web. 01 May 2016.

Dutta, Debasish. "Arduino MPPT Solar Charge Controller." *Hackaday.io*. Hackaday, 16 Sept. 2015. Web. 30 Apr. 2016.

EngBlaze. "EngBlaze." *EngBlaze*. Amazon, 2016. Web. 01 May 2016.

Gironi, Davide. "A Simple Brushless Sensorless Motor Driver for AVR Atmega." *Davide Gironi: A Simple Brushless Sensorless Motor Driver for AVR Atmega*. Blogspot.com, 30 Sept. 2013. Web. 01 May 2016.

SeaPro Fact Sheet, GE Power & Water, Jul. 2013

Schmidt, Windsor. "KiCAD Quick-Start Tutorial." *YouTube*. YouTube, 09 July 2015. Web. 01 May 2016.

Semig, Peter, and Collin Wells. "A Current Sensing Tutorial--Part 1: Fundamentals | EE Times." *EETimes*. UBM, n.d. Web. 01 May 2016.

Shirriff, Ken. "Secrets of Arduino PWM." *Ken Shirriff's Blog*. Righto.com, 2009. Web. 01 May 2016.

"Synchronous Speed of Electrical Motors." *Synchronous Speed of Electrical Motors*. N.p., n.d. Web. 30 Apr. 2016.

Texasinstruments. "BUCK BOOST POWER STAGE - Tutorial with Bernd Geck (part 3)." *YouTube*. YouTube, 16 Aug. 2011. Web. 30 Apr. 2016.

Field Maintenance Manual, US Windpower

<http://www.airfoiltools.com/>

<http://www.q-blade.org/>

Lyon, C.A., Broeren, A.P., Giguere, P., Gopalarathnam, A and Selig, M.S., Summary of Low Speed Airfoil Data, Volume 3, SoarTech Publications, 1997.

Manwell, J. F. , McGowan, J. G. , and Rogers, A. L. , Wind Energy Explained: Theory, Design and Application, 2nd edition, Wiley, 2009

Wood, David, Small Wind Turbines: Analysis, Design, and Application, Springer-Verlag, 2011

Selig, M.S., and Guglielmo, J.J., "High Lift Low Reynolds Number Airfoil Design", *Journal of Aircraft*, Vol 34, No. 1, 1997