

# **ENERGY STORAGE**

***a view from the trenches***

**DOE EAC Energy Storage Panel**

**June 2, 2016**

# About Wellhead

---

- WEC is a Sacramento based IPP since 1985
- We develop and our with affiliates own and operate generating projects
  - Over 350 MW currently operating in California – solar and gas
  - Have PPAs for additional 100 MW with more in the pipeline
- Have a 50 MW project in New York
- Have built projects for multiple utilities
- Have survived with technology innovation and wise use of our funds
- Wellhead Power Solutions, LLC is the owner of a new storage hybrid technology – the EGT

# EGT™ Overview

## Primary equipment

- The Wellhead Power Solutions, LLC (“WPS”) EGT™ system consists of a 10MW/5MWh General Electric Co. (“GE”) Battery Energy Storage System (“BESS”) that is fully integrated (patent pending) with new or existing GE LM6000 aero-derivative gas turbines (gas turbine requires some upgrades).

## Products

- At a high level, the EGT™ adds 10 MW of high speed capability *into* the existing LM6000 operating range, *not* on top of the existing operating range.
- This allows the EGT™ to provide high speed energy, ancillary and grid support services, at a lower cost and smaller GHG footprint than traditional thermal resources *and* without the energy neutrality issues associated with stand-alone storage.

## Unique EGT™ attributes

- No Pmin
- Full fidelity of operating range (0MW to 50MW)
- 50 MW of GHG-free spinning reserve
- 25 MW of *high speed*, accurate regulation
- 50 MW of peaking energy for local contingencies
- -8 to + 5 MVAR voltage support without fuel burn
- Primary Frequency Response, without fuel burn (reduces cost to comply with NERC BAL-003-1)
- RT Battery State of Charge managed by GT (provides max availability of reserves without duration constraints, and will not charge counter to ACE or system energy peak).
- Superior transient response due to electrical co-location of GT and Battery
- Black Start capability

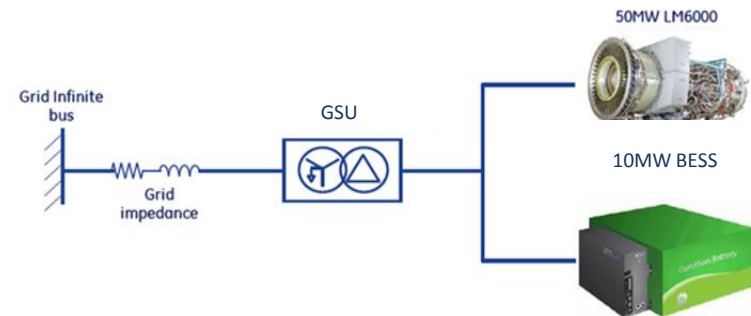

# The California Business Case

---

The EGT™ Business Case encompasses a large number of specific components of value that can be generally summarized as:

- Quantifiable ratepayer benefits from Ancillary Services cost to the CAISO system and load serving entities
- Quantifiable ratepayer benefits from reduced energy cost to the CAISO system and load serving entities
- Direct reductions in GHG emissions and facilitation of the transition to zero-GHG intermittent resources
- Direct savings from reduced life cycle costs of operations, including fuel and start/cycle costs of the GT

# Observations as a Storage Developer

There has been denial of the extent of the reliability issues (and costs) a renewable future brings.

There is a high degree of interest in finding ways to use storage most effectively.

Innovators are typically ahead of regulatory agencies and regulated entities.

The value propositions are not easily evaluated.

Making changes through stakeholder processes takes time and often leads mainstream thinking.

There remains work to be done to ensure clarity.

# **ONE ADDITIONAL SLIDE of possible interest**

**(I understand it may tie into yesterdays discussions)**

# The Problem We Are Chasing

This graph shows real time five minute volatility (as the change from day ahead hourly forecast) in the load that must be met by dispatchable system resources for the period from 4:00 pm 3/2/2019 to 12:45 pm 3/3/2019 using sequential simulations with PLEXOS

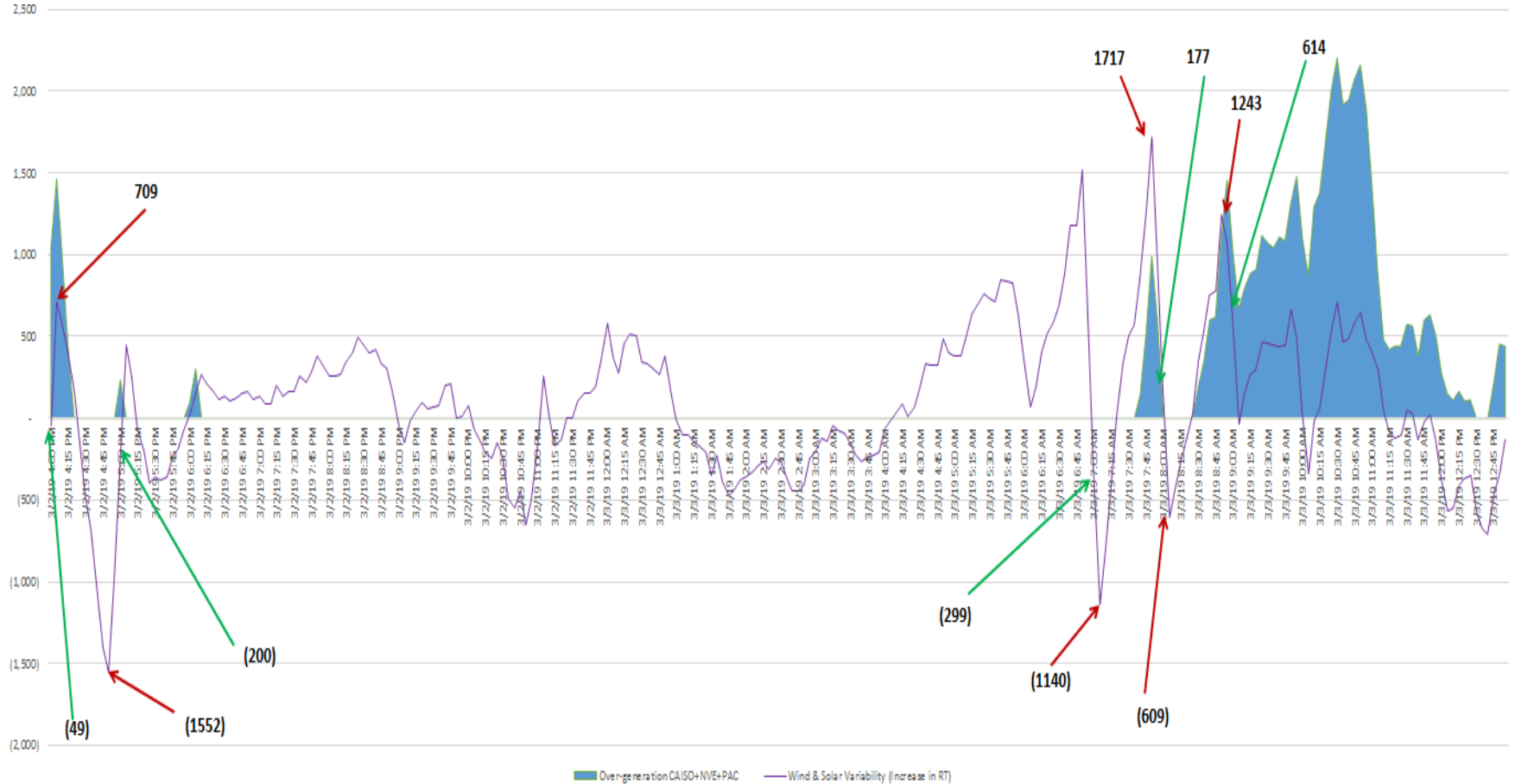

Harold E. Dittmer, President, Wellhead Electric Company, Inc.  
Harold E. Dittmer, President, Wellhead Power Solutions, LLC  
(916) 447-5171  
Email: [hdittmer@wellhead.com](mailto:hdittmer@wellhead.com)

Doug Davie, Vice President  
Wellhead Electric Company, Inc.  
(916) 447-5171  
Email: [ddavie@wellhead.com](mailto:ddavie@wellhead.com)

Grant McDaniel, EGT Project Manager  
Wellhead Services, Inc.  
(916) 447-5171  
Email: [gmcdaniel@wellhead.com](mailto:gmcdaniel@wellhead.com)