

# **MANUFACTURING COST ANALYSIS OF 10 kW AND 25 kW DIRECT HYDROGEN POLYMER ELECTROLYTE MEMBRANE (PEM) FUEL CELL FOR MATERIAL HANDLING APPLICATIONS**

Prepared by:  
BATTELLE

Battelle Memorial Institute  
505 King Avenue  
Columbus, OH 43201

Prepared for:  
U.S. Department of Energy  
Golden Field Office  
Golden, CO  
DOE Contract No. DE-EE0005250

March 25, 2013



*This report is a work prepared for the United States Government by Battelle. In no event shall either the United States Government or Battelle have any responsibility or liability for any consequences of any use, misuse, inability to use, or reliance upon the information contained herein, nor does either warrant or otherwise represent in any way the accuracy, adequacy, efficacy, or applicability of the contents hereof.*

## Table of Contents

|    |  |    |
|----|--|----|
| 1  | INTRODUCTION .....   | 1  |
| 2  | APPROACH .....   | 1  |
| 3  | MARKET ANALYSIS .....  | 3  |
|    | 3.1 Market Summary.....  | 4  |
|    | 3.2 Technology Selection.....  | 6  |
|    | 3.3 Conclusions.....   | 11 |
| 4  | SYSTEM SPECIFICATIONS .....  | 12 |
|    | 4.1 General Description .....  | 12 |
|    | 4.2 Electrical System.....   | 15 |
|    | 4.3 Balance of Plant (BOP).....  | 17 |
| 5  | MANUFACTURING COST ASSUMPTIONS.....  | 18 |
|    | 5.1 Stack Manufacturing Process and Cost Assumptions .....                             | 18 |
|    | 5.2 Electrical System Cost Assumptions .....   | 23 |
|    | 5.3 Balance of Plant Cost Assumptions .....  | 26 |
|    | 5.4 System Assembly and Learning Curve Assumptions .....                               | 31 |
|    | 5.5 Capital Cost Assumptions.....  | 32 |
| 6  | LIMITATIONS OF THE ANALYSIS .....  | 33 |
|    | 6.1 Manufacturing Costs .....  | 33 |
|    | 6.2 Balance of Plant Hardware Costs.....   | 34 |
| 7  | COST ANALYSIS RESULTS .....  | 34 |
|    | 7.1 10 kW Cost Analysis Results.....   | 34 |
|    | 7.2 25 kW Cost Analysis Results.....   | 36 |
| 8  | SENSITIVITY ANALYSIS.....  | 38 |
| 9  | LIFECYCLE COST ANALYSIS OF FUEL CELLS .....  | 41 |
| 10 | CONCLUSIONS.....   | 43 |
|    | 10.1 System Cost Summary .....   | 43 |
|    | 10.2 Results.....  | 48 |
|    | Appendix A – Stack Manufacturing Process and Cost Assumptions .....                    | 2  |
|    | A.1 Bipolar Plate Manufacturing Process Documentation .....                            | 2  |
|    | A.2 End Plate Manufacturing Process Documentation.....                                 | 8  |
|    | A.3 Gasket Manufacturing Process Documentation .....                                   | 13 |
|    | A.4 Membrane Electrode Assembly (MEA) Hot Processing Manufacturing Documentation ..... | 18 |
|    | A.5 Membrane/Catalyst Manufacturing Process Documentation.....                         | 24 |
|    | A.6 Cost Comparison to DTI 2010.....   | 36 |
|    | A.7 Assembly Cost Learning Curve Calculations .....                                    | 39 |

## List of Figures

|              |   |    |
|--------------|---|----|
| Figure 2-1.  | Battelle’s Cost Analysis Approach .....   | 2  |
| Figure 3-1.  | Distribution of Class 4 & 5 Forklift Truck Power Ranges.....  | 8  |
| Figure 3-2.  | CDPARRA-MHE-23: Average Daily Fuel Cell Operation Hours (by fleet).....   | 9  |
| Figure 3-3.  | Distribution of Class 7 Forklift Truck Power Range .....  | 11 |
| Figure 4-1.  | PEM System Schematic for 10 kW and 25 kW MHE Applications .....   | 13 |
| Figure 5-1.  | Fuel Cell Stack Manufacturing Process .....   | 19 |
| Figure 5-2.  | Distribution of Costs across Components for 10 kW Design. ....  | 29 |
| Figure 5-3.  | Distribution of Costs across Components for 25 kW Design. ....  | 29 |
| Figure 5-4.  | Variation in Balance of Plant Costs with Different Hydrogen Storage Systems .....   | 31 |
| Figure 7-1.  | Cost Breakdown of 10 kW Stack .....   | 35 |
| Figure 7-2.  | 10 kW MHE PEM Fuel Cell BOP Hardware Cost Breakdown (i.e. No System Assembly) .....   | 35 |
| Figure 7-3.  | 10 kW MHE PEM Fuel Cell BOP Hardware Cost Breakdown (i.e. No System Assembly) without Battery and Hydrogen Storage System.....  | 36 |
| Figure 7-4.  | Cost Breakdown of 25 kW Stack .....   | 37 |
| Figure 7-5.  | 25 kW MHE PEM Fuel Cell BOP Hardware Cost Breakdown (i.e. No System Assembly) .....   | 38 |
| Figure 7-6.  | 25 kW MHE PEM Fuel Cell BOP Hardware Cost Breakdown (i.e. No System Assembly) Without Battery and Hydrogen Storage System ..... | 38 |
| Figure 8-1.  | Sensitivity Analysis: 10 kW Stack Cost – 10,000 Production Volume .....   | 40 |
| Figure 8-2.  | Sensitivity Analysis: 25 kW Stack Cost – 10,000 Production Volume .....   | 40 |
| Figure 10-1. | Distribution of Costs for 10 kW System (100 units/yr) .....   | 44 |
| Figure 10-2. | Distribution of Costs for 10 kW System (1,000 units/yr) .....   | 45 |
| Figure 10-3. | Distribution of Costs for 10 kW System (10,000 units/yr) .....  | 45 |
| Figure 10-4. | Distribution of Costs for 25 kW System (100 units/yr) .....   | 46 |
| Figure 10-5. | Distribution of Costs for 25 kW System (1,000 units/yr) .....   | 47 |
| Figure 10-6. | Distribution of Costs for 25 kW System (10,000 units/yr) .....  | 47 |
| Figure A-1.  | Bipolar Plate Manufacturing Process.....  | 2  |
| Figure A-2.  | End Plate Manufacturing Process .....   | 9  |
| Figure A-3.  | DFM Analysis for 10 KW End Plate .....  | 12 |
| Figure A-4.  | DFM Analysis for 25 KW End Plate .....  | 13 |
| Figure A-5.  | Gasket Manufacturing Process.....   | 14 |
| Figure A-6.  | MEA Hot Processing Manufacturing Process.....   | 18 |
| Figure A-7.  | Membrane / Catalyst Manufacturing Process .....   | 26 |

## List of Tables

|            |   |    |
|------------|---|----|
| Table 3-1. | System Operating Requirements for Material Handling Equipment with High Potential for Fuel Cell Technology..... | 5  |
| Table 3-2. | MHE Application Matrix.....   | 7  |
| Table 4-1. | Specifications by Component Function.....   | 14 |
| Table 4-2. | Fuel Cell Design Characteristics.....   | 15 |
| Table 5-1. | General FC Stack Process Cost Assumptions.....  | 18 |
| Table 5-2. | End Plate Cost Summary .....  | 20 |
| Table 5-3. | Bipolar Plate Cost Summary.....   | 20 |
| Table 5-4. | Coolant Gasket Cost Summary.....  | 21 |
| Table 5-5. | Material Cost Assumptions.....  | 22 |

|             |  |    |
|-------------|--|----|
| Table 5-6.  | MEA Cost Summary.....  | 22 |
| Table 5-7.  | MEA Material Cost Summary .....  | 22 |
| Table 5-8.  | Stack Assembly Costs.....  | 23 |
| Table 5-9.  | Lithium-Ion Battery Cost Breakdown .....   | 25 |
| Table 5-10. | Component Costs for the 10 kW MHE System .....   | 27 |
| Table 5-11. | Component Costs for the 25 kW System.....  | 28 |
| Table 5-12. | Composite versus All-Steel Tank Costs .....  | 30 |
| Table 5-13. | Summary System Assembly Cost Assumptions.....  | 32 |
| Table 5-14. | Summary of Capital Cost Assumptions.....   | 32 |
| Table 6-1.  | Manufacturing Processes Evaluated .....  | 33 |
| Table 7-1.  | 10 kW MHE PEM Fuel Cell Stack Manufacturing Cost Summary .....   | 34 |
| Table 7-2.  | 10 kW MHE PEM Fuel Cell BOP Manufacturing Cost Summary .....   | 35 |
| Table 7-3.  | 10 kW MHE PEM Fuel Cell System Cost Summary .....  | 36 |
| Table 7-4.  | 25 kW MHE PEM Fuel Cell Stack Manufacturing Cost Summary .....   | 37 |
| Table 7-5.  | 25 kW MHE PEM Fuel Cell BOP Manufacturing Cost Summary .....   | 37 |
| Table 7-6.  | 25 kW MHE PEM Fuel Cell System Cost Summary .....  | 38 |
| Table 9-1.  | Cost Assumptions for Fuel Cell Forklift and Battery Powered Forklift for 2 Shift<br>Operations for Approximately 9 hours Per Day. ....   | 42 |
| Table 9-2.  | Net Present Value Analysis of Fuel Cell and Battery Powered Forklifts for 2 Shift<br>Operations for Approximately 9 hours Per Day. ....  | 43 |
| Table 9-3.. | Net Present Value Analysis of Fuel Cell and Battery Powered Forklifts for 3 Shift<br>Operations for Approximately 16 hours Per Day. .... | 43 |
| Table 10-1. | 10 kW MHE PEM Fuel Cell System per Unit Cost Summary .....   | 43 |
| Table 10-2. | 25 kW MHE PEM Fuel Cell System Per Unit Cost Summary.....  | 46 |

# 1 Introduction

Battelle is conducting manufacturing cost assessments of fuel cells for stationary and non-automotive applications to identify the primary cost drivers impacting successful product commercialization. Battelle, under a 5-year cooperative agreement with the Department of Energy's (DOE's) Fuel Cell Program, will provide an independent assessment of fuel cell manufacturing costs at varied volumes and alternative system designs. This report provides cost estimates for the manufacture of 10 kW and 25 kW polymer electrolyte membrane (PEM) fuel cells designed for material handling applications. This report identifies the manufacturing costs of fuel cells using high-volume manufacturing processes at annual production volumes of 100, 1000, and 100,000 units. The system design and manufacturing volumes were defined using Battelle's fuel cell system integration expertise and refined through a discussion with industry partners. The report presents our approach; the design of the system, design assumptions, and manufacturing processes modeled using the design for manufacturing assembly (DFMA®) software; costs of the system, sub-system, and specific components; the main cost drivers identified through a sensitivity analysis; and a summary of opportunities for cost reduction.

## 2 Approach

Battelle's cost analysis methodology is a four-step approach (Figure 2-1):

Step 1 – Market Assessment

Step 2 – System Design

Step 3 – Cost Modeling

Step 4 – Sensitivity Analysis/Lifecycle Cost Analysis.

This approach has been successfully applied to previous cost analysis developed by Battelle.<sup>1,2</sup>

---

<sup>1</sup> Battelle. 2011. The High Volume Manufacture Cost Analysis of 5 kW Direct Hydrogen Polymer Electrolyte Membrane (PEM) Fuel Cell for Backup Power Applications. Contract No. DE-FC36GO13110.

<sup>2</sup> H. Stone, K. Mahadevan, K. Judd, H. Stein, V. Contini, J. Myers, J. Sanford, J. Amaya, and D. Paul. 2006. Economics of Stationary Proton Exchange Membrane Fuel Cells, Interim Report. Contract No. DE-FC36GO13110.

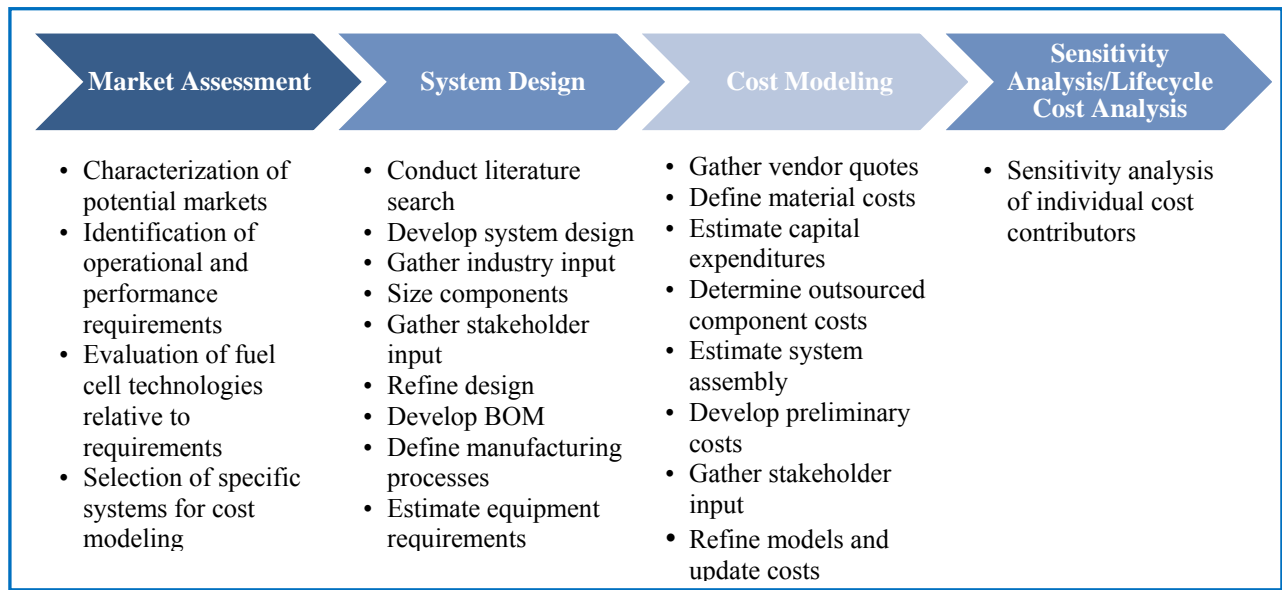

**Figure 2-1. Battelle’s Cost Analysis Approach**

The first step in our methodology, *Step 1 Market Assessment*, is to ensure that we select the right fuel cell type and appropriate production volumes to meet market requirements. In this step, we identified the operational and performance requirements (e.g., hours of operation, frequency, lifetime expected) of the target application and market. Using this information, an assessment of the user requirements for a fuel cell product was defined. We also completed a quick survey of the market through an industry dialogue to estimate the number of units in the market and the expected market growth for fuel cells in material handling applications. This information formed the basis for selecting the right system design and fuel cell type for user requirements and the appropriate production volumes to consider in the modeling exercise.

*Step 2 System Design*, a literature review of fuel cell designs for forklift applications, component design and manufacturing processes, possible improvements in system design and manufacturing was completed. From these results the basic construction and operational parameters for a fuel cell stack and system will be defined as well as potential improvements. The fuel cell design developed will not focus on an individual manufacturer’s designs, but a system representative of typical design based on literature and engineering expertise of Battelle. The stack and system design will be vetted with industry stakeholders to ensure feasibility of the design, identify possible improvements, and to determine current and alternate manufacturing approaches. A finalized design and projected improvements will be published and will form the basis for developing the bill of materials (BOM). Decisions then will be made about which components are manufactured internally and which are outsourced. For internally manufactured components (including applicable balance of plant (BOP) components), manufacturing processes, and production equipment will be defined in detail.

In *Step 3 Cost Modeling*, Battelle gathered vendor quotes for material costs, production equipment, and outsourced components. Custom manufacturing process models were defined where necessary and

parametrically modeled based on knowledge of the machine, energy and labor requirements for individual steps that comprise the custom process. The sequence of actions required to assemble the components and test the final fuel cell system were developed and analyzed for cost reduction opportunities through component consolidation and process optimization. Manufacturing quality control required was based on suggestions of equipment vendors and Battelle's experience with product manufacturing. Outsourced components costs were estimated through vendor quotes. Mathematic functions for scaling factors were developed to estimate the changes to outsourced components and material costs with production volumes when vendor quotes for higher volumes are not available. These were derived using engineering rules of thumb and estimates from other manufacturing processes and considered impacts on system design. Using the Design for Manufacturing Assembly (DFMA<sup>®</sup>) software, component costs calculated from both custom and library manufacturing processes and the outsourced components were incorporated into the assembly and test sequence models to determine the final cost of producing the fuel cell systems. The output of the DFMA<sup>®</sup> models were also used to calculate production line utilization to determine the number of individual process lines required to support various product demand levels, as input to the manufacturing capital cost model. Capital equipment expenditures for production will be amortized over a 20-year period and the annual amortized cost will be distributed over production volume for that year. Financial assumptions that were used are consistent with the DOE Hydrogen Analysis (H2A) model. Total stack system costs including capital expenditures were then estimated for the baseline system and projected improvements.

In *Step 4 Sensitivity Analysis*, a sensitivity analysis was performed to determine which design parameters or assumptions have the most effect upon the stack and system cost. Single factor sensitivity analysis was performed. Single factor sensitivity analysis helps determine the impact of individual parameters on system costs. . Based on these results, insights into the design optimization of fuel cell systems are provided to reduce the total system cost and total cost of ownership.

### 3 Market Analysis

Battelle performed a market analysis to support the selection of the system and fuel cell type for the cost analysis.<sup>3</sup> For this study, Battelle focused on fuel cell systems for material handling applications. Battelle reviewed various types of material handling equipment to gain a general understanding of the characteristics and equipment types available in the market. The various types of equipment were first divided into conventional and computer-aided equipment, and then further subdivided into specific types of equipment such as hoisting, conveying, surface and overhead under conventional and robotics, computer controlled conveyor, and automatic guided vehicles under computer aided material handling equipment.

---

<sup>3</sup> Battelle, 2012. Task 2: Market and Application Requirements to Support Fuel Cell Design: Material Handling Equipment. Report to the DOE. DOE Contract No. DE-EE0005250/001.



### 3.1 Market Summary

Battelle assessed the potential for fuel cell technology to be adopted in material handling applications. Battelle sought to identify those applications where fuel cell characteristics could meet or exceed the performance of currently deployed equipment. Aspects of performance considered include power, responsiveness, efficiency, operability, and emissions (both air emissions and noise emissions). Fixed location material handling applications are commonly grid connected giving them fast response, more than adequate power, high efficiency, and cleanliness. For the niche of fixed location applications with critical operation, fuel cells offer benefits as back-up power, particularly when extended run times are required. Fuel cells could also offer substantial benefit where local emissions and noise ordinances limit the operating time of diesel engines to a few hundred hours per year. Applications that require a mobile power source, high operational time, and locally low emissions and/or noise (e.g., indoors) are predominantly battery powered devices. In these applications, fuel cells can significantly out-perform the currently deployed technology by providing essentially continuous or near continuous power, thus eliminating recharging or battery exchange. These advantages are likely to remain regardless of advances in battery technology.

Three types of material handling equipment were identified as having a high potential for fuel cell technology: AGVs (Automated Guided Vehicles), forklifts, and industrial trucks. Table 3-1 summarizes general system operating requirements for these equipment types. Having the capability for near continuous operation is a common requirement across all three equipment types, although the daily operational requirement for any specific application varies. Users generally expect equipment to last 15 years or more with heavy use. A fairly fast start-up time is common. For systems powered by battery or IC engine, the nominal motor power listed in Table 3-2 is essentially the peak power.

Class I, II, and III forklifts are a demonstrated early market for PEM fuel cell technologies. PEM systems with power outputs ranging from 1 to 10 kW have been incorporated into hybrid power modules capable of delivering peak powers up to 50 kW for short durations. The adoption is facilitated by governmental economic incentives, primarily the Emergency Economic Stabilization Act of 2008 and the American Recovery and Reinvestment Act of 2009 as well as state-specific incentives. Even in the absence of incentives, a compelling economic argument can be made for fuel cell powered material handling equipment with high daily usage requirements.<sup>4</sup>

Industrial trucks (Class 6 MHE) can have many of the same usage profile characteristics as Class 1, 2, and 3 forklifts. In general, industrial trucks are used in fewer numbers than forklifts. However, as with the Class 1, 2, and 3 equipment, a favorable argument for fuel cell powered systems may be made for applications that include a high number of operational hours each day, limitations on emissions, or limitations on noise. A hydrogen fuel cell has been incorporated (65kW fuel cell system) and a terminal tractor (16 kW fuel cell system).<sup>5</sup>

---

<sup>4</sup> [http://www1.eere.energy.gov/hydrogenandfuelcells/pdfs/market\\_transformation.pdf](http://www1.eere.energy.gov/hydrogenandfuelcells/pdfs/market_transformation.pdf)

<sup>5</sup> Vision Motor Corp. Product Specs: Terminal Tractors. <http://visionmotorcorp.com/zett.asp> and <http://visionmotorcorp.com/tyrano.asp>

**Table 3-1. System Operating Requirements for Material Handling Equipment with High Potential for Fuel Cell Technology**

| Equipment Type              | Maximum Duty Cycle      | Start-up Time | Equipment Lifetime | Power Module Lifetime                                 | Nominal Motor Power |
|-----------------------------|-------------------------|---------------|--------------------|---|---------------------|
| AGVs - Industrial           | Near continuous, 24/7   | 0-5 min       | 12-15 years        | battery: 6-8 years                                    | 1-30 kW             |
| AGVs - Commercial           | 4 hours of 8-hour shift | 0-5 min       | 20 years           | battery: 6-8 years                                    | <1 kW               |
| Forklifts - Class 1 & 2     | Near continuous, 24/7   | 0-5 min       | 12-15 years        | battery: 3-5 years<br>fuel cell: 2 years <sup>6</sup> | 5-20 kW             |
| Forklifts - Class 3         | Near continuous, 24/7   | 0-5 min       | 12-15 years        | battery: 3-5 years<br>fuel cell: 2 years              | 3-5 kW              |
| Forklifts - Class 4 & 5     | Near continuous, 24/7   | 0-5 min       | 20 years           | IC engine: 10,000-15,000 hours                        | 25-225 kW           |
| Industrial Trucks - Class 6 | 18 hours daily          | 0-5 min       | 20 years           | battery: 10,000 hours                                 | 1-50 kW             |
| Forklifts - Class 7         | Near continuous, 24/7   | 0-5 min       | 20 years           | IC engine: 10,000-15,000 hours                        | 20-130 kW           |

Fuel cells have begun to be used in AGVs. The AGV market is small and varied, with requirements dependent on customer needs. Equipment typically requires <1 kW to 5 kW but may range up to 30 kW for heavy industrial AGVs. One company has implemented two fleets of AGVs (software-guided counterbalance forklifts) powered by fuel cell technologies: one is powered by hydrogen PEM fuel cells, and the other uses on-board direct methanol fuel cell battery chargers to keep the batteries at near full charge.<sup>7</sup>

High temperature PEM and SOFC fuel cell systems lag PEM fuel cell systems in maturity. All of the current production and/or demonstration fuel cell material handling applications use PEM (direct methanol being assumed a subset of PEM). However, as these alternative technologies mature, they may prove attractive in some applications.

In considering the application of HTPEM or SOFC to materials handling, the unique operating characteristics of these technologies will influence the practicality of their application. HTPEM performs very similarly to conventional PEM but may require somewhat longer start times due to the higher

<sup>6</sup> <http://www.plugpower.com/Solutions/FAQ.aspx>

<sup>7</sup> Renewable Energy Focus. 2009. FMC trialing Plug Power, Oorja fuel cells for automatic guided vehicles. <http://www.renewableenergyfocus.com/view/2977/fmc-trialing-plug-power-oorja-fuel-cells-for-automatic-guided-vehicles/>.

operating temperature. HTPEM does, however, require a smaller radiator for heat rejection and can provide operator cab heating in some applications. As the daily operational time increases, the start-up time becomes less important.

SOFC systems require even longer start-up times and generally do not respond quickly to load changes. However, in a hybridized system (with batteries, supercapacitors, or both) SOFC may serve well if the load on the fuel cell system can be managed to a near constant value. Such load management should be possible in many warehouse and industrial settings by charging/ discharging a properly sized capacitor or battery bank. The limitations of SOFC are being addressed by work sponsored under the SECA program.

### 3.2 Technology Selection

Having identified potential markets and general application requirements, Battelle identified fuel cell technologies best suited to meet those needs. The operating requirements identified in Table 3-2 include the nominal motor power. In typical material handling applications, there are only brief periods where the full nominal power is required (i.e. lifting or overcoming stationary inertia). For a battery or IC engine power module, the power module must be capable of supplying this power level entirely on its own. For a fuel cell power module, a smaller fuel cell system can be hybridized with batteries or supercapacitors to meet the infrequent peak power demands. NREL ARRA composite data product CDPARRA-MHE-17 shows that for about 85% of the time in a fleet of hybridized fuel cell powered forklifts, the fuel cell system is operating at less than 50% of its rated capacity.<sup>8</sup> When taken into consideration with the capabilities and accepted performance of deployed systems, a fuel cell system rated for 25% to 50% of the nominal required power could be incorporated into a hybrid system that would meet the application requirements. The exact ratio is dependent upon the specific application requirements and typical drive cycles. Battelle's market research completed in this task indicates existing Class 1, 2, and 3 equipment powered by fuel cells fall within these bounds.

Battelle started with the entire range of systems sizes and technologies specified in the funding announcement, DOE FOA-0000420. A matrix of possible systems was constructed using the system (size and fuel cell type) as columns and the specific MHE application as rows. From this matrix, individual systems were selected for consideration in FY12 by process of elimination based upon typical market applications and requirements, state of technology development, or basic economic arguments. These reasons are identified with letters in Table 3-3 and explained in detail below the table.

The main objectives of the research being funded by DOE are to advance the technology and reduce the fuel cell and total system costs. Therefore it is anticipated that the selection matrix will be reconsidered in future years based on the technological advances and results of work on this project.

Note that in selecting system sizes for consideration, Battelle has chosen to retain the fuel cell system power sizes specified in the FOA to maintain a consistent basis for comparison across DOE projects. For

---

<sup>8</sup> NREL Composite Data Product CDPARRA-MHE-17:  
[http://www.nrel.gov/hydrogen/cfm/docs/cdparra\\_mhe\\_17\\_stackpower.ppt](http://www.nrel.gov/hydrogen/cfm/docs/cdparra_mhe_17_stackpower.ppt)

example, if an application would ideally use a 3 kW fuel cell system size, Battelle would choose to consider 1 kW and 5 kW.

**Table 3-2. MHE Application Matrix**

| Technology      |         | PEM    | HTPEM | SOFC | PEM    | HTPEM | SOFC | PEM   | HTPEM | SOFC | PEM   | HTPEM | SOFC | PEM    | HTPEM | SOFC | PEM    | HTPEM | SOFC |
|-----------------|---------|--------|-------|------|--------|-------|------|-------|-------|------|-------|-------|------|--------|-------|------|--------|-------|------|
|                 |         | 1 kW   |       |      | 5 kW   |       |      | 10 kW |       |      | 25 kW |       |      | 100 kW |       |      | 250 kW |       |      |
| MHE Application | Class 1 | Yellow | G     | D    | Yellow | G     | D    | Green | G     | D    | Red   | Red   | Red  | Red    | Red   | Red  | Red    | Red   | Red  |
|                 | Class 2 | Yellow | G     | D    | Yellow | G     | D    | Green | G     | D    | Red   | Red   | Red  | Red    | Red   | Red  | Red    | Red   | Red  |
|                 | Class 3 | Yellow | G     | D    | Yellow | G     | D    | Red   | Red   | Red  | Red   | Red   | Red  | Red    | Red   | Red  | Red    | Red   | Red  |
|                 | Class 4 | C      | C     | C    | C      | C     | C    | Green | G     | G    | Green | G     | G    | C      | C     | C    | Red    | Red   | Red  |
|                 | Class 5 | C      | C     | C    | C      | C     | C    | Green | G     | G    | Green | G     | G    | C      | C     | C    | Red    | Red   | Red  |
|                 | Class 6 | Yellow | G     | D    | Yellow | G     | D    | Green | G     | G    | Green | G     | G    | Red    | Red   | Red  | Red    | Red   | Red  |
|                 | Class 7 | Red    | Red   | Red  | Red    | Red   | Red  | I     | I     | I    | I     | I     | I    | I      | I     | I    | Red    | Red   | Red  |
|                 | AGV     | Yellow | G     | D    | Yellow | G     | D    | A     | A     | A    | Red   | Red   | Red  | Red    | Red   | Red  | Red    | Red   | Red  |

**Key**

|  |   |
|--|---|
|  | Considered in FY12  |
|  | Considered in FY13  |
|  | Fall outside the application ranges in Table 2  |
|  | Lower priority, will be reconsidered in future years as technology and market requirements change |

- A. As identified in Tables 3-1 and 3-2, existing AGV equipment motor sizes span from less than 1 kW to 30 kW. The majority of motor sizes are in the 1 to 5 kW range. A 1 kW fuel cell system in a hybrid power module is applicable to meet this requirement. Although it may be oversized for most applications, Battelle recommends that a 5 kW fuel cell system in a hybrid power module also be considered to better understand the effect of fuel cell system size on total cost.
- B. As shown in Table 3-1, Class 6 equipment is one of the most diverse categories of material handling equipment. The distribution of current systems motor sizes is predominantly 60 kW and less. Fuel cell systems rated for 100 and 250 kW would be unnecessarily oversized.
- C. As shown in Table 3-1, Class 4 and 5 equipment ranges up to 450 kW. The majority (99.4%) of equipment falls between 19 and 130 kW according to EPA nonroad engine population estimates.<sup>9</sup> The distribution of system sizes is shown in Figure 3. Assuming a hybrid fuel cell system has a peak power approximately twice the fuel cell system power, fuel cell system sizes of 10 and 25 kW could meet the requirements of about 75% of the existing equipment. To meet the entire application range, a hybrid fuel cell system with a fuel cell system size from 50 to 100 kW may be applicable depending on the specific duty cycle required. Battelle recommends that consideration of the largest size be deferred until future years. The cost analysis of systems of 10 kW and 25 kW fuel cell system size can be used to determine if there is an economic justification for fuel cell powered equipment to meet the needs of similar existing Class 4 and 5 equipment.

<sup>9</sup> EPA Nonroad Engine Population Estimation, EPA-420-R-05-022, December 2005

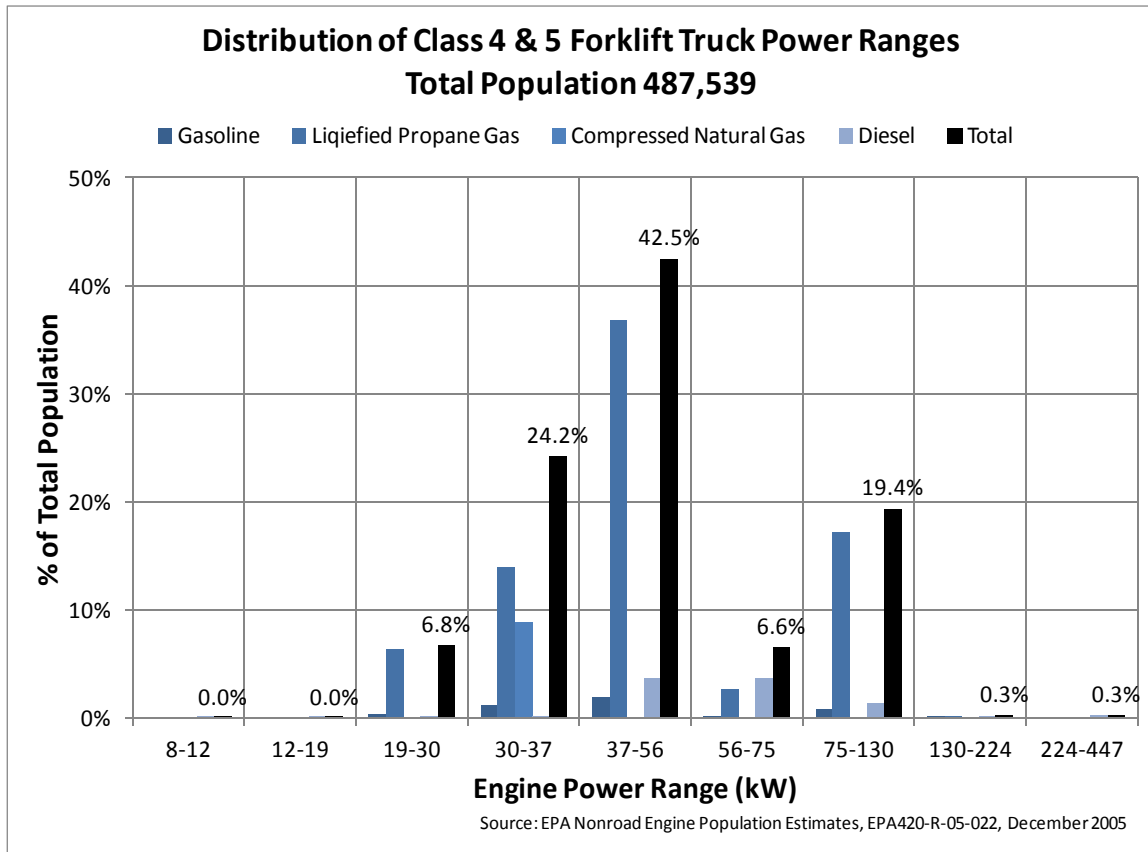
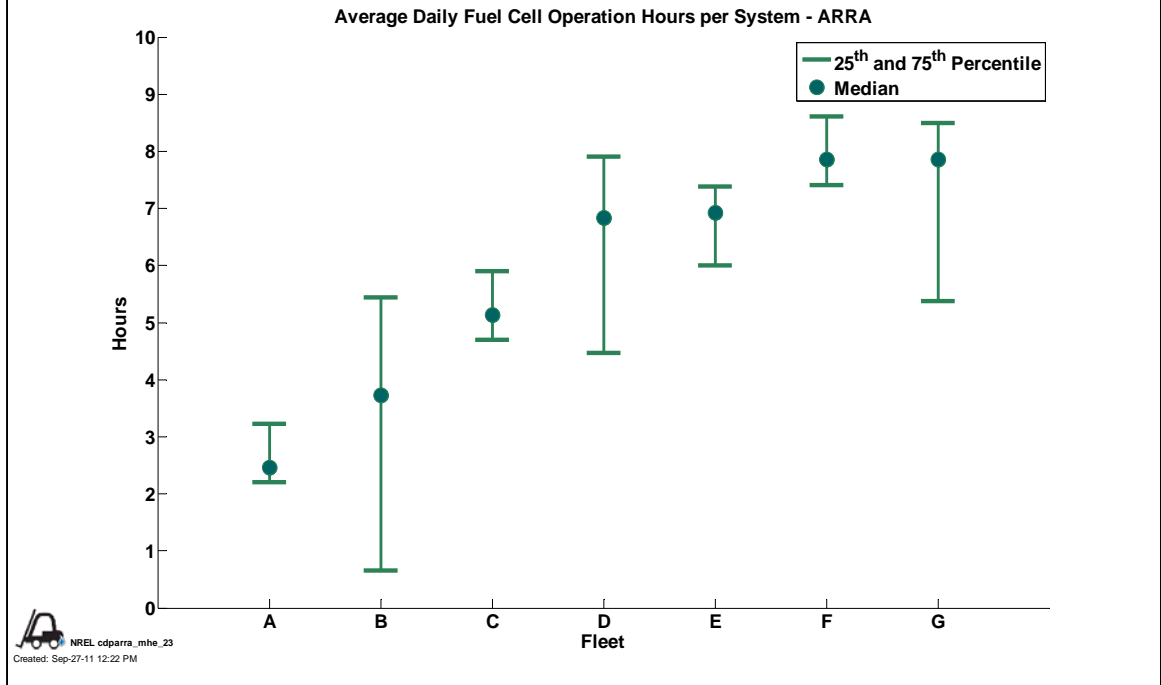

**Figure 3-1. Distribution of Class 4 & 5 Forklift Truck Power Ranges**

D. Although the economic argument for fuel cell powered MHE is based upon a large number of daily operational hours, NREL ARRA composite data product CDPARRA-MHE-23, shown in Figure 4, indicates the majority of applications operate fewer than 8 hours per day. As such, the high number of start/stops associated with SOFC technology, or losses in standby mode, indicate that SOFC technology is not the best technology fit for MHE applications.<sup>10</sup>

<sup>10</sup> NREL Composite Data Product CDPARRA-MHE-23:  
[http://www.nrel.gov/hydrogen/cfm/docs/cdparra\\_mhe\\_23\\_dailyfcophoursperfleet.ppt](http://www.nrel.gov/hydrogen/cfm/docs/cdparra_mhe_23_dailyfcophoursperfleet.ppt)

## CDPARRA-MHE-23 Average Daily Fuel Cell Operation Hours per Fleet



**Figure 3-2. CDPARRA-MHE-23: Average Daily Fuel Cell Operation Hours (by fleet)**

- E. As shown in Tables 3-1 and 3-2, Class 1 & 2 equipment generally ranges from 5 to 20 kW system size. These power ranges can be met with hybrid power modules ranging from 3 to 10 kW fuel cell system size. A 1 kW fuel cell system is likely undersized, but is not removed from consideration based upon this criteria.
- F. As shown in Tables 3-1 and 3-2, Class 3 equipment generally ranges from 1-5 kW system size. Although the specific design may be slightly undersized or oversized, hybrid systems incorporating 1 kW and 5 kW fuel cell systems will maintain a consistent basis across DOE projects.
- G. NREL ARRA composite data product CDPARRA-MHE-42 indicates that a 100 kg/day refueling station would meet the needs of current fleet deployments.<sup>11</sup> H2A analysis estimates of forecourt production costs of hydrogen (per kg) for 2015 are:<sup>12</sup>

\$2.44 from Tube Trailer

<sup>11</sup> NREL Composite Data Product CDPARRA-MHE-42:

[http://www.nrel.gov/hydrogen/cfm/docs/cdparra\\_mhe\\_42\\_h2kgperday.ppt](http://www.nrel.gov/hydrogen/cfm/docs/cdparra_mhe_42_h2kgperday.ppt)

<sup>12</sup> [http://hydrogen.pnl.gov/filedownloads/hydrogen/datasheets/H2A\\_case\\_results\\_june\\_2005II.xls](http://hydrogen.pnl.gov/filedownloads/hydrogen/datasheets/H2A_case_results_june_2005II.xls)

\$3.04 from Liquid H2  
\$8.73 from Electrolysis  
\$5.85 from steam methane reforming (SMR)

Both High Temperature PEM and SOFC technologies do not require pure hydrogen fuel, so the H2A analysis results for pure hydrogen production are likely higher than what would be required to produce adequate fuel for those fuel cell types. Consider the \$5.85/kg cost of H2 from methane reforming. This cost is comprised of

\$1.43 Feedstock Operation and Maintenance (O&M)  
\$2.39 Capital Cost  
\$1.76 Fixed O&M Cost  
\$0.27 Other Variable Cost Contribution

Assuming a cost of \$5.5407/mmBtu<sup>13</sup> for natural gas and standard conversion factors, the raw fuel cost for hydrogen delivered by natural gas is approximately \$0.65/kg H2 (45% of the Feedstock O&M cost). The capital cost is split between production (54%) and compression, storage, and dispensing (46%). Assuming that the O&M costs and variable costs are similarly divided, the forecourt cost of fueling SOFC fuel cell systems can be estimated at 45% of the SMR cost, \$2.63/kg H2. This price is cost competitive with pure hydrogen delivered by tube trailer or liquid H2.

PEM technology is the most technically mature fuel cell technology in consideration. Therefore there is a higher likelihood of it meeting application requirements than competing fuel cell technologies. Since the raw fuel costs also do not indicate an inherent advantage in using SOFC or HTPEM technologies, it is suggested that consideration of these systems be deferred until cost analysis on 80C PEM fuel cell systems for the low power MHE (1 & 5 kW) results can be compared to results for diesel fueled APU (also 1 & 5 kW). Although the applications are not identical, there will likely be enough commonality to determine the relative costs of the fuel cell systems. Based on the comparison, the higher cost of fuel produced on site may be offset by an inherently lower fuel cell system cost.

- H. The Class 7 forklift population is about ¼ the population of Class 4 & 5 forklifts. About 90% of the population has system sizes ranging from 37 to 130 kW.<sup>14</sup> Hybrid power modules with fuel cell system sizes of 10 and 25 kW would meet the requirements of a good portion of this equipment. A 100 kW fuel cell system is likely oversized, but could be considered for some of the higher power Class 7 forklifts.

---

<sup>13</sup> [http://www.hydrogen.energy.gov/analysis\\_repository/project.cfm/PID=236](http://www.hydrogen.energy.gov/analysis_repository/project.cfm/PID=236)

<sup>14</sup> EPA Nonroad Engine Population Estimation, EPA-420-R-05-022, December 2005

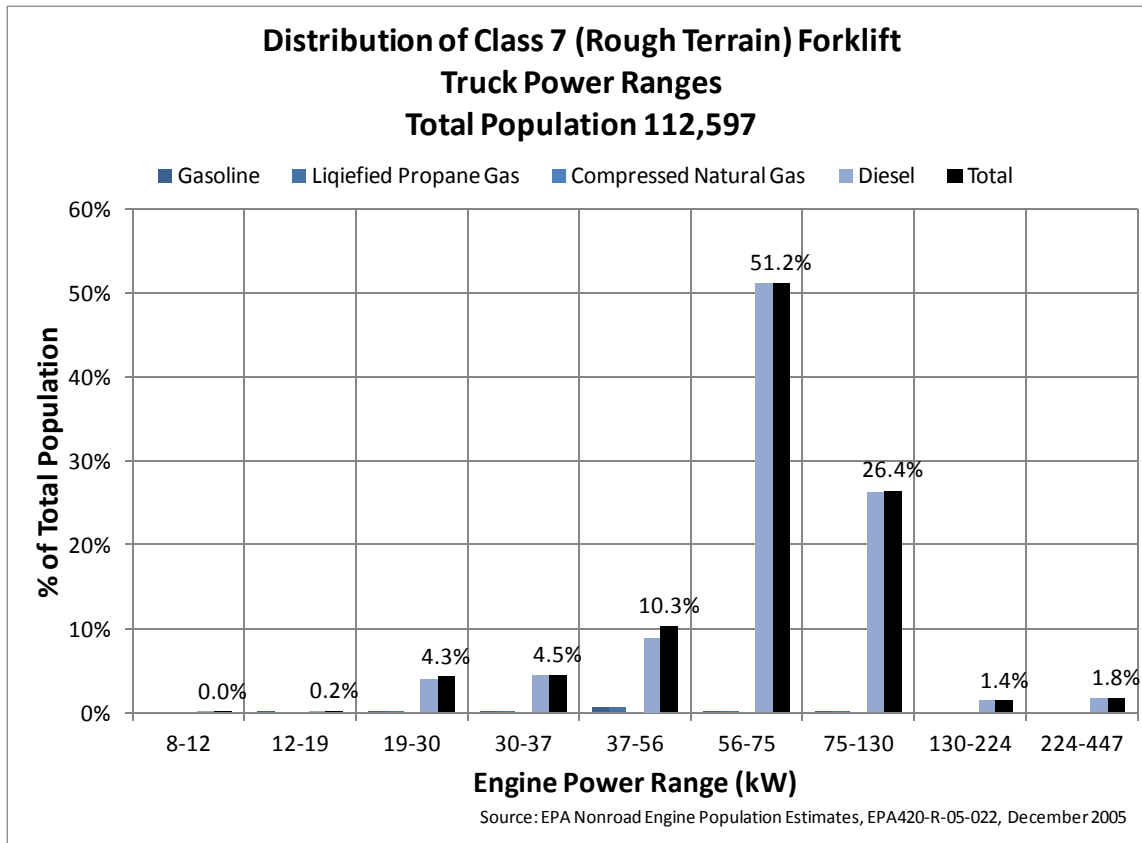

**Figure 3-3. Distribution of Class 7 Forklift Truck Power Range**

- I. The technical challenges associated with Class 7 forklifts, rough terrain applications by definition, make this class of equipment a less suitable application for market penetration. In addition to meeting the requirements of other classes of forklifts, Class 7 equipment must include considerations for harsher shock loads and a greater range of orientation of the fuel cell system during duty, which causes challenges with water management.

### 3.3 Conclusions

Based on the results of the market analysis, Battelle proposed to conduct a cost analysis of a general fuel cell system for MHE equipment that would meet the needs of several specific applications. Specifically, Battelle considered 80°C (nominal) PEM-hybrid systems of 10 and 25 kW fuel cell system power with peak power capability of 150% – 200% of fuel cell system power. The fuel cell system would be designed for a lifetime of 10,000 hours and capable of operating 24/7 with normal intervals of refueling.

In FY13 the analysis will be extended to include 1 kW and 5 kW 80°C (nominal) PEM-hybrid systems for similar general MHE applications. Additionally, the technology selection matrix will be reconsidered in FY13. While the market application and associated system sizes are not expected to change substantially, technological development of SOFC and HTPEM may make them a more suitable fuel cell



system technology for MHE applications. Additional insights into these technologies gained during the concurrent cost analysis of APU systems by Battelle will help quantify the potential economic aspects of these technologies.

## 4 System Specifications

This section presents a general description of the system, electrical system specifications, and balance of plant assumptions.

### 4.1 General Description

Based on a market study that evaluated market requirements, technological readiness, and barriers to implementation, Battelle considered 10 kW and 25 kW (net) fuel cell power systems for material handling equipment (MHE). The 25 kW system design is applicable to equipment designated as Class 6, Lift Code 1 (Sit-Down Rider, Draw Bar Pull over 999 lbs). A 10 kW fuel cell power system is applicable to both Class 6 equipment as well as several lift codes of Class 1 and 2 equipment.

The power system is powered by a standard temperature PEM fuel cell hybridized with an appropriate means of energy storage for peak demands and transient response. The system schematic for a generic 10 kW and 25 kW MHE application is shown in Figure 4-1.

In the configuration shown in Figure 4-1, hydrogen is stored at 350 bar (~5,000 psi), passes through a dual stage regulator, and then supplies the stack at 2 psig. Excess hydrogen is recirculated with an oil-free, hydrogen specific blower. While recirculating hydrogen is a cost adder at the BOP level, it improves overall stack life and expands the operating range. In this setup, the anode should never be starved of fuel. It would be necessary to periodically purge excess hydrogen to the atmosphere.

The cathode airstream is drawn from the atmosphere and passes through a chemical and particulate filter. The airstream is humidified as it flows through a gas-to-gas Nafion® tube humidifier, where moisture is drawn from the cathode exhaust. The process is an open-loop cycle where the cathode exhaust air provides moisture to the cathode inlet air. As the airstream flows through the stack it inherently collects moisture, which is then transferred to the supply airstream via Nafion® membranes. What is remaining of the cathode exhaust is then released to the atmosphere. In general, humidification can be accomplished with other methods such as enthalpy wheels or planar membranes. At current production quantities, enthalpy wheels were found to have comparable costs with Nafion® tubes. As for the planar membranes, a 2011 Honeywell study<sup>15</sup> has suggested that they may not be as efficient as their alternatives. A new membrane and humidifier design is on the horizon though, as Gore and DuPont utilized a new membrane material in a humidifier module engineered in a 2010-2012 project.<sup>16</sup> The positive results may result in cost savings. No matter what the method, humidification enables higher stack operating temperature and a broader operating range in general. However, this benefit comes at a high expense, because

---

<sup>15</sup> Mirza, Zia. "Development of Thermal and Water Management System for PEM Fuel Cell," Honeywell Aerospace, Project ID FC066; 5/9/11.

<sup>16</sup> Johnson, William. "Materials and Modules for Low-Cost, High Performance Fuel Cell Humidifiers," W.L. Gore & Associates, Inc, Project ID FC067; 5/17/12.

humidification hardware is a significant cost adder. Stack and humidifier manufacturers alike are constantly looking for cost reductions or, in the case of some stack vendors, ways to eliminate the need for humidification all together.

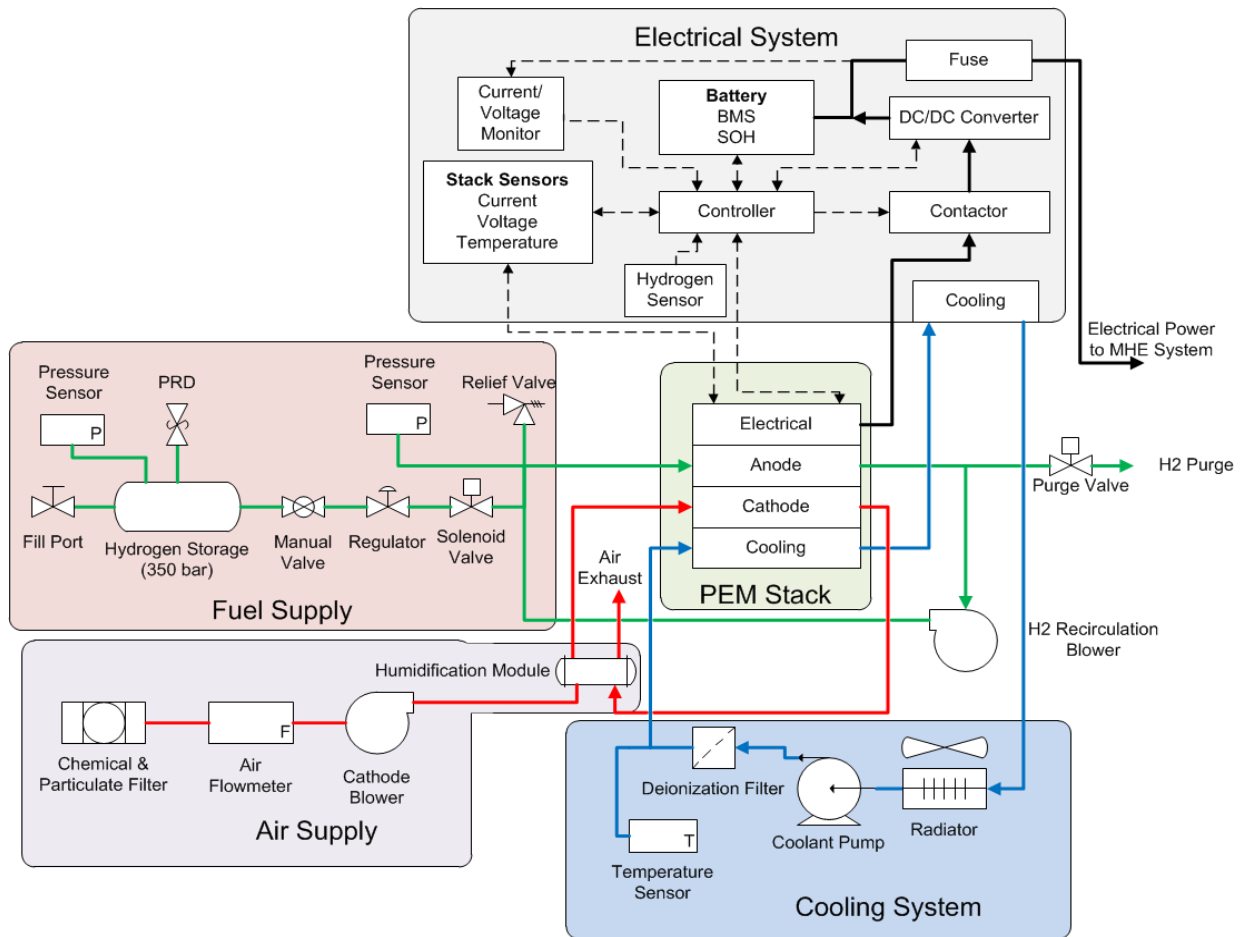

**Figure 4-1. PEM System Schematic for 10 kW and 25 kW MHE Applications**

While anode humidification reduces the chance of local fuel starvation, thereby improving stack life and expanding operating range, it is not a necessity as concluded from stakeholder feedback. Furthermore, its elimination represents a cost reduction. It was therefore not incorporated in analyzed systems.

A liquid cooling loop circulates a water-glycol mixture throughout the system for thermal management. The liquid passes through a radiator heat exchanger, pump, and deionization filter before flowing through the channels in the stack's bipolar plates. Coolant temperature is monitored and can be used to modify the pump's performance if needed. Stack sensors (current, voltage, temperature) also provide feedback and are connected to the control module to ensure the stack is operating correctly. For safety concerns, a hydrogen sensor is installed onboard to identify any possible leaks during operation. The electrical control system, sensors, and some peripheral components are powered from a secondary DC/DC converter that

connects to the 48 VDC main power output. All electrical instrumentation is sent through a DC/DC converter, where it is adjusted to the desired 48 VDC.

Overall the system schematic remains the same for 10 kW and 25 kW systems. Many of the physical components need to be scaled up to accommodate the larger 25 kW system, but the general layout remains the same. Sizing accommodations were made appropriately for the mechanical, electrical, and computer components when costing both systems. Table 4-1 provides a summary of specifications by component function; Table 4-2 provides details on the fuel cell design.

**Table 4-1. Specifications by Component Function**

| Component            | Specification  |
|----------------------|--|
| <b>Fuel (Anode)</b>  | <ul style="list-style-type: none"> <li>• 99.95% H<sub>2</sub>, fueled at a centralized plant location</li> <li>• Fuel stored onboard at 350 bar</li> <li>• No humidification</li> <li>• Regulated to 2 psig pressure at the stack</li> <li>• Recirculation with periodic purges</li> </ul>         |
| <b>Air (Cathode)</b> | <ul style="list-style-type: none"> <li>• Filtered for particulates and chemicals (passive)</li> <li>• Humidification</li> <li>• Flow is 2.5X stoichiometric</li> </ul>   |
| <b>Cooling</b>       | <ul style="list-style-type: none"> <li>• Liquid cooled (low conductivity glycol/de-ionized water mixture in a closed-loop path)</li> </ul>   |
| <b>Electric</b>      | <ul style="list-style-type: none"> <li>• 48 VDC regulated output</li> <li>• Buck DC/DC converter</li> <li>• Hybridized system with Li-ion technology to supply short bursts of peak power</li> <li>• Peak power requirements nominally 300% of net fuel cell power and last for 3–5 sec</li> </ul> |
| <b>General</b>       | <ul style="list-style-type: none"> <li>• 10,000 hr lifetime</li> <li>• Includes ballast to maintain comparable system weight with competitor products</li> </ul>   |

**Table 4-2. Fuel Cell Design Characteristics**

| Parameter                                      | 10 kW System  | 25 kW System |
|--|---|--------------|
| Power Density (W/cm <sup>2</sup> )             | 0.65  |              |
| Current Density (A/cm <sup>2</sup> )           | 1.0   |              |
| Cell Voltage (VDC)                             | 0.65  |              |
| Active Area Per Cell (cm <sup>2</sup> )        | 200   | 400          |
| Net Power (kW)                                 | 10  | 25           |
| Gross Power (kW)                               | 11  | 27.5         |
| Number of Cells (#)                            | 85  | 106          |
| Full Load Stack Voltage (VDC)                  | 55  | 69           |
| Membrane Base Material                         | PFSA, 0.2mm thick, PTFE reinforced                                    |              |
| Catalyst Loading                               | 0.6 mg Pt/cm <sup>2</sup> (total)<br>Cathode is 2:1 relative to Anode |              |
| Catalyst Application                           | Catalyst ink prepared, sprayed deposition, heat dried, decal transfer |              |
| Gas diffusion layer (GDL) Base Material        | Carbon paper 0.2 mm thick   |              |
| GDL Construction                               | Carbon paper dip-coated with PTFE for water management                |              |
| Membrane electrode assembly (MEA) Construction | Hot press and die cut   |              |
| Seals  | 1 mm silicone, die cut  |              |
| Stack Assembly                                 | Hand assembled, tie rods  |              |
| Bipolar Plates                                 | Graphite composite, compression molded                                |              |
| End Plates                                     | Machined cast aluminum  |              |

## 4.2 Electrical System

The major components of the fuel cell electrical system are DC/DC converters, energy storage, thermal management, control and sensor feedback, protective devices, cables, and connectors. The assumed topology for this effort is just one of many design possibilities. This topology was selected based on industry feedback and general knowledge of the components and the application. The primary role of the electrical system is to manage the transfer of power to the load. The components of this system are sized with the assumption that the fuel cell provides the nominal power consumed by the equipment and the power required to recharge the battery while the battery provides the power required in excess of the nominal power. These periods of excess power or peak loads were assumed to be no more than 3 times the maximum output power of the fuel cell for ten seconds or less. The following sections provide more detail on each of the major components in the electrical system.

### 4.2.1 DC/DC Converters

The high power DC/DC converter is located between the fuel cell and the battery. This converter regulates the varying output voltage and simultaneously acts as a battery charger. The converter has the ability to regulate the output voltage while monitoring current and to regulate the output current while

monitoring voltage. In addition, it is capable of communicating the voltage and current to the system controls.

The converter is a step-down (buck) converter. This converter topology was selected because it is well defined, consists of minimal components, and can be very efficient at high power levels. For this topology to work properly, the fuel cell output voltage at full load must be higher than the nominal operating voltage of the batteries, in this case 48V. The buck circuit configuration is non-isolated. High current levels are often achieved via placing multiple buck modules in parallel; however, single modules that provide all the current are also an option.

A smaller DC/DC converter is used to power to the control electronics and miscellaneous support equipment in the system. This converter generates a lower, more tightly regulated voltage from the 48 V power bus for the electronics in the system.

### ***4.2.2 Energy Storage***

Lithium ion batteries are used for the energy storage component of the design because of their high energy/power density relative to other battery technologies. This attribute allows the overall footprint of the battery to be smaller relative to other chemistries. In addition, they have no memory effect, are capable of high charge/discharge rates and, when managed properly, have a long life. For this effort, the peak load requirement drove the selection of the batteries. It is assumed that a battery capable of handling the peak power requirement for this application has sufficient energy capacity for continuous operation without breaks for recharging.

It is also assumed that the battery has a battery management system (BMS), protection features built into the modules and perhaps even the cells inside the pack, and a method of communicating the state of health to the system controller. These features are included in the design because of the inherent safety risks when using lithium chemistries. The cost associated with these assumptions is built into the cost estimates for the battery pack.

Other energy storage options exist. Lead acid batteries are a more affordable solution than lithium and are tolerant to rapid charge and discharge, but the volume constraints may limit the ability to incorporate this chemistry into the pack. Ultracapacitors are also an option, but the main limitation with this technology is its limited energy density. Certain applications where the load profile is less demanding could allow for an ultracapacitor solution.

### ***4.2.3 Thermal Management***

The DC/DC converter and the batteries produce a significant amount of heat, and this heat must be rejected from the system. For both the 10 kW and 25 kW systems, the heat is rejected via a liquid cooling loop. This is the same loop that is used to cool the fuel cell components. The assumption is that the cooling plates are part of the design of each component.

### ***4.2.4 Control and Sensors***

A system controller is required to process sensor feedback signals, issue commands to components, monitor the status of system components and processes, and interface to any gauges or user feedback devices. The controller communicates with the fuel cell and battery to obtain the health and status of those

components. Other sensors such as the hydrogen safety sensor, the output current transducer, and the voltage monitoring circuit provide feedback signals to the controller as well. All of these signals are used to control the operation of the system.

#### ***4.2.5 Protective Devices***

The protective components are intended to prevent catastrophic failures and to protect the user from harm. Certain components may have internal protection devices such as current limiting on the output of the DC/DC converter, or fuses internal to the battery. In addition, there could be downstream protective devices on the material handling equipment that negate the use of these components. A contactor is used on the fuel cell output because the output voltage of the fuel cell is higher than the recommend maximum safe DC touch voltage. This contactor disconnects the fuel cell when the system is not in use and in the event of a system failure or safety concern. The contactor is hermetically sealed in order to contain any arcing that might occur when closing or opening under load. The fuse on the output is there to prevent damage from a short circuit on the output.

#### ***4.2.6 Connector and Cabling***

The output connection of the fuel cell system must interface to the existing power plug. This is a high current connection that must be maintained in order for the fuel cell power system to be a drop-in replacement for the lead acid battery. The connectors and cables that complete all the interconnections between electrical components in the system must be rated for the environment in which the equipment is to be used. As a result automotive style water resistance connectors are used in this design. The wire and cable is assumed to be of the same quality as those used in the automotive industry as well.

#### ***4.2.7 Alternative Electrical Systems***

Alternative electrical system designs exist that seek to simplify or reduce the component cost in the system by removing the DC/DC converter and directly connecting the fuel cell to the batteries. This approach eliminates the cost of the converter at the potential expense of more complicated battery management electronics, additional electronics to manage power flow, a more stringent battery selection, and possibly a more involved stack design.

In general, power pack designs are constrained by volume and weight to match the characteristics of the lead acid battery they are replacing. If the forklift were designed with the fuel cell system in mind, more space could be allocated to accommodate different battery technologies.

### **4.3 Balance of Plant (BOP)**

The system specifications were used to derive the requirements for specific BOP components. Suitable components that met these requirements were identified from multiple manufacturers. The associated costs were then obtained by soliciting quotes or price estimates from a minimum of three manufacturers when possible. The multiple quotes were then compared to one another to develop a generic cost. However, three quotes could not be obtained in some instances, such as when a unique component was

produced by one, widely accepted manufacturer or simply was not a commercial-off-the-shelf (COTS) part.

The majority of BOP components are readily available and costing could be estimated at the larger volumes of 1,000 and 10,000 units. For those few items that are currently not being produced at large quantities, a vendor either provided budgetary pricing or a suitable discount was assumed for mass production. This was often the case for blowers and hydrogen-specific components.

Three main components that are not readily available commercial items are the cathode flow meter, the electronic control unit (ECU), and the system controller. Both the ECU and system controller are custom items in the control module, and are designed to interface with the stack instrumentation and the system as a whole, respectively. The cost of these custom parts was estimated by combining Battelle's general experience, end-user feedback, and original equipment manufacturer (OEM) aftermarket auto sales of similar products. Similarly, no suitable COTS item was identified for the cathode flow meter. Scientific instruments for measuring air flow are generally not suitable for system implementation due to the low flow and pressure drop requirements. PEM systems currently on the market use automotive OEM parts that have been proprietarily modified or flow meters that are still undergoing research and development. Consequently, costs for the flow meter were obtained using retail prices for replacement automotive parts and suitable quantity scaling factors.

## 5 Manufacturing Cost Assumptions

Using the DFMA<sup>®</sup> software, component costs calculated from both custom and library manufacturing processes and the outsourced components were incorporated into the assembly and test sequence models to determine the final cost of producing the fuel cell systems. The output of the DFMA<sup>®</sup> models were also used to calculate production line utilization to determine the number of individual process lines required to support various product demand levels, as input to the manufacturing capital cost model. Capital equipment expenditures for production were amortized over a 20-year period and the annual amortized cost was distributed over the production volume for that year. Financial assumptions that will be used are consistent with the DOE Hydrogen Analysis (H2A) model. Total stack system costs including capital expenditures were then estimated for the baseline system and projected improvements.

### 5.1 Stack Manufacturing Process and Cost Assumptions

The stack consists of end plates, bipolar plates, coolant gaskets, and membrane electrode assembly (MEA) as shown in Figure 5.1. General process cost assumptions are presented in Table 5-1 below. Refer to Appendix A for details of the analysis.

**Table 5-1. General FC Stack Process Cost Assumptions**

|                                 |            |
|---------------------------------|------------|
| <b>Labor cost</b>               | \$45.00/hr |
| <b>Machine cost</b>             | \$25.00/hr |
| <b>Energy cost</b>              | \$0.07/kWh |
| <b>Overall plant efficiency</b> | 85.00%     |

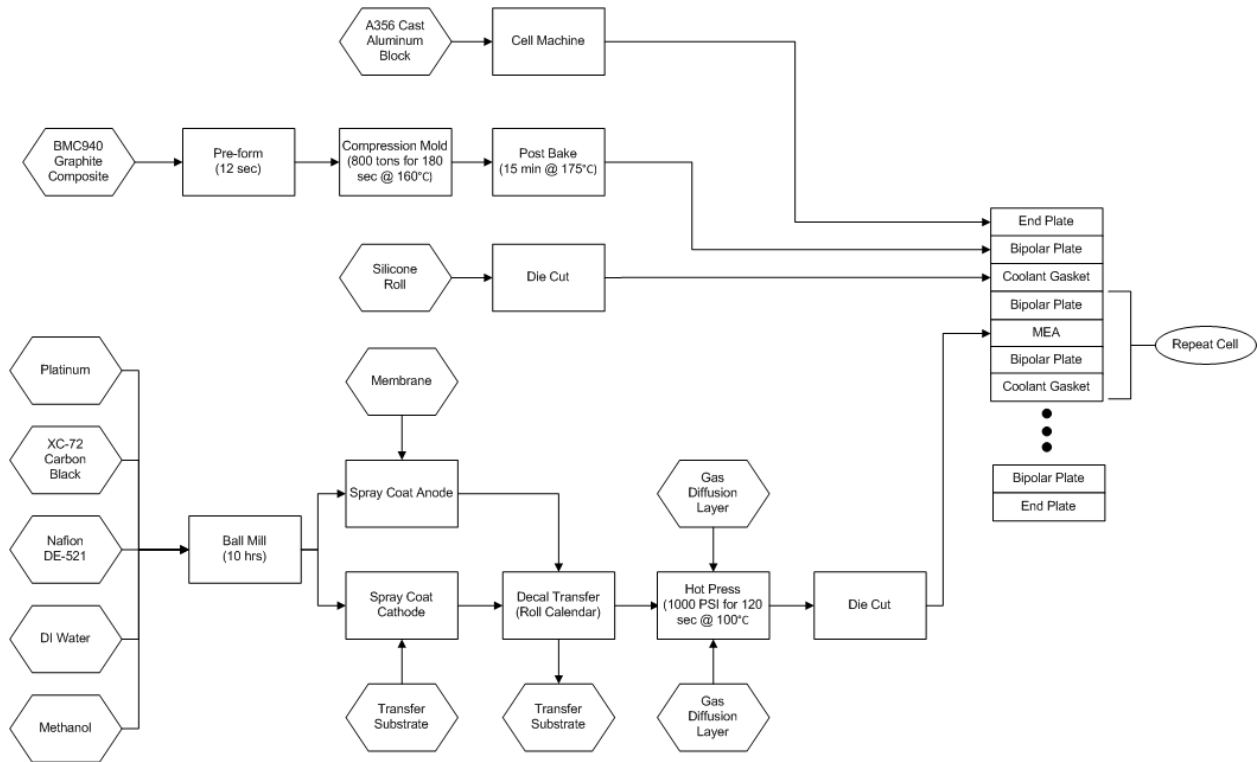

**Figure 5-1. Fuel Cell Stack Manufacturing Process**

### 5.1.1 End Plates

The end plates align with the fuel cell stack across the length of the plate, and overhang the stack width by 20 mm on each side to accommodate the eight tie rods that will press and hold the stack together. The end plate has four reamed and tapped holes for mounting fuel and exhaust gas connectors. The process selected to produce the end plates was cell machining of an A356 cast aluminum block using a Haas VMC machining center. For all volumes, the material cost was assumed to be \$2.54/kg, and the process scrap rate was assumed to be 0.5%. The end plate cost summary is provided in Table 5-2.



**Table 5-2. End Plate Cost Summary**

|                     | 10 kW            |                  |                  | 25 kW            |                  |                  |
|---------------------|------------------|------------------|------------------|------------------|------------------|------------------|
|                     | 100              | 1000             | 10000            | 100              | 1000             | 10000            |
| <b>Material</b>     | \$8.56           | \$8.56           | \$8.56           | \$13.66          | \$13.66          | \$13.66          |
| <b>Labor</b>        | \$0.04           | \$0.04           | \$0.04           | \$0.04           | \$0.04           | \$0.04           |
| <b>Machine</b>      | \$18.11          | \$18.11          | \$18.11          | \$26.36          | \$26.36          | \$26.36          |
| <b>Energy</b>       | \$0.00           | \$0.00           | \$0.00           | \$0.00           | \$0.00           | \$0.00           |
| <b>Scrap</b>        | \$0.12           | \$0.12           | \$0.12           | \$0.18           | \$0.18           | \$0.18           |
| <b>Tooling</b>      | \$0.00           | \$0.00           | \$0.00           | \$0.00           | \$0.00           | \$0.00           |
| <b>Part Total</b>   | <b>\$26.83</b>   | <b>\$26.83</b>   | <b>\$26.83</b>   | <b>\$40.24</b>   | <b>\$40.24</b>   | <b>\$40.24</b>   |
| <b>Stack Count</b>  | 2                | 2                | 2                | 2                | 2                | 2                |
| <b>Stack Total</b>  | \$53.66          | \$53.66          | \$53.66          | \$80.48          | \$80.48          | \$80.48          |
| <b>Capital Cost</b> | <b>\$150,000</b> | <b>\$150,000</b> | <b>\$150,000</b> | <b>\$150,000</b> | <b>\$150,000</b> | <b>\$150,000</b> |

### 5.1.2 Bipolar Plants

The bipolar plates are a compression molded graphite composite material. The material is preformed into the approximate rectangular shape of the plate, then molded using 800 tons of pressure at 160°C. Following molding, the plates are baked at 175°C for 15 minutes. For all volumes, the material cost was assumed to be \$2.43/kg, and the process scrap rate was assumed to be 2.5%. The bipolar plate cost summary is provided in Table 5-3.

**Table 5-3. Bipolar Plate Cost Summary**

|                            | 10 kW            |                  |                    | 25 kW            |                  |                    |
|----------------------------|------------------|------------------|--------------------|------------------|------------------|--------------------|
|                            | 100              | 1000             | 10000              | 100              | 1000             | 10000              |
| <b>Material</b>            | \$0.60           | \$0.60           | \$0.60             | \$0.99           | \$0.99           | \$0.99             |
| <b>Labor</b>               | \$1.31           | \$1.31           | \$1.30             | \$2.32           | \$2.31           | \$2.31             |
| <b>Machine</b>             | \$1.51           | \$1.51           | \$1.51             | \$2.03           | \$2.03           | \$2.03             |
| <b>Energy</b>              | \$0.23           | \$0.23           | \$0.23             | \$0.37           | \$0.37           | \$0.37             |
| <b>Scrap</b>               | \$0.07           | \$0.07           | \$0.07             | \$0.12           | \$0.12           | \$0.11             |
| <b>Tooling</b>             | \$0.50           | \$0.50           | \$0.50             | \$1.01           | \$1.08           | \$1.01             |
| <b>Part Total</b>          | <b>\$4.22</b>    | <b>\$4.22</b>    | <b>\$4.21</b>      | <b>\$6.83</b>    | <b>\$6.89</b>    | <b>\$6.81</b>      |
| <b>Stack Count</b>         | 172              | 172              | 172                | 214              | 214              | 214                |
| <b>Stack Total</b>         | \$726.18         | \$724.98         | \$724.29           | \$1,460.76       | \$1,474.89       | \$1,456.70         |
| <b>Capital Cost</b>        | <b>\$764,315</b> | <b>\$764,315</b> | <b>\$3,057,260</b> | <b>\$764,315</b> | <b>\$764,315</b> | <b>\$7,643,150</b> |
| <b>\$/kW<sub>net</sub></b> | \$72.62          | \$72.50          | \$72.43            | \$58.43          | \$59.00          | \$58.27            |

### 5.1.3 Coolant Gaskets

The coolant gaskets are die cut from silicone roll stock material using a standard steel rule die on a press capable to punching 4 gaskets simultaneously. For all volumes, the material cost was assumed to be \$35.88/m<sup>2</sup>, and the process scrap rate was assumed to be 0.5%. The coolant gasket cost summary is provided in Table 5-4.

**Table 5-4. Coolant Gasket Cost Summary**

|                     | 10 kW            |                  |                  | 25 kW            |                  |                  |
|---------------------|------------------|------------------|------------------|------------------|------------------|------------------|
|                     | 100              | 1000             | 10000            | 100              | 1000             | 10000            |
| <b>Material</b>     | \$1.51           | \$1.51           | \$1.51           | \$2.45           | \$2.45           | \$2.45           |
| <b>Labor</b>        | \$0.09           | \$0.09           | \$0.09           | \$0.14           | \$0.14           | \$0.14           |
| <b>Machine</b>      | \$0.00           | \$0.00           | \$0.00           | \$0.00           | \$0.00           | \$0.00           |
| <b>Energy</b>       | \$0.00           | \$0.00           | \$0.00           | \$0.00           | \$0.00           | \$0.00           |
| <b>Scrap</b>        | \$0.01           | \$0.01           | \$0.01           | \$0.01           | \$0.01           | \$0.01           |
| <b>Tooling</b>      | \$0.01           | \$0.01           | \$0.01           | \$0.01           | \$0.01           | \$0.01           |
| <b>Part Total</b>   | <b>\$1.62</b>    | <b>\$1.62</b>    | <b>\$1.62</b>    | <b>\$2.62</b>    | <b>\$2.62</b>    | <b>\$2.62</b>    |
| <b>Stack Count</b>  | 86               | 86               | 86               | 107              | 107              | 107              |
| <b>Stack Total</b>  | \$139.41         | \$139.23         | \$139.32         | \$279.81         | \$280.13         | \$280.13         |
| <b>Capital Cost</b> | <b>\$125,000</b> | <b>\$125,000</b> | <b>\$125,000</b> | <b>\$125,000</b> | <b>\$125,000</b> | <b>\$125,000</b> |

### 5.1.4 Membrane Electrode Assembly (MEA)

The MEA is built up in layers starting with the catalyzed membrane. The components of the catalyst ink are ball-milled into a uniform suspension. The thinner anode layer is spray coated directly on the hydrated membrane and dried, while the thicker cathode layer is spray coated onto a transfer substrate and dried. The two catalyst layers are then heated and roll pressed, with the transfer substrate peeled away from the cathode layer following pressing. The catalyzed membrane is then hot pressed between two gas diffusion layers and die cut to final cell dimensions. For all volumes, the scrap rate was assumed to be 5.5% (2.5% for catalyst application; 3.0% for hot pressing). Material costs were assumed as listed in Table 5-5. The MEA cost summary is provided in Table 5-6. A detailed breakdown of material cost by MEA layer is provided in Table 5-7.

**Table 5-5. Material Cost Assumptions**

| Material           | Annual Volume (stacks)  |                         |                         |
|--------------------|-------------------------|-------------------------|-------------------------|
|                    | 100                     | 1000                    | 10000                   |
|                    | Material Cost           | Material Cost           | Material Cost           |
| Platinum           | \$1,390.00/tr.oz.       | \$1,390.00/tr.oz.       | \$1,390.00/tr.oz.       |
| Nafion® DE-521     | \$2,750.00/kg           | \$2,350.00/kg           | \$1,100.00/kg           |
| XC-72 carbon black | \$18.00/kg              | \$18.00/kg              | \$18.00/kg              |
| DI water           | \$0.11/kg               | \$0.11/kg               | \$0.11/kg               |
| Methanol           | \$0.50/kg               | \$0.50/kg               | \$0.50/kg               |
| Membrane           | \$250.00/m <sup>2</sup> | \$224.00/m <sup>2</sup> | \$180.00/m <sup>2</sup> |
| GDL                | \$95.00/m <sup>2</sup>  | \$72.00/m <sup>2</sup>  | \$60.00/m <sup>2</sup>  |

**Table 5-6. MEA Cost Summary**

| Material            | 10 kW            |                  |                  | 25 kW            |                  |                  |
|---------------------|------------------|------------------|------------------|------------------|------------------|------------------|
|                     | 100              | 1000             | 10000            | 100              | 1000             | 10000            |
| Material            | \$37.70          | \$33.55          | \$27.16          | \$62.69          | \$55.79          | \$44.91          |
| Labor               | \$0.37           | \$0.35           | \$0.34           | \$0.44           | \$0.53           | \$0.43           |
| Machine             | \$0.20           | \$0.18           | \$0.18           | \$0.23           | \$0.21           | \$0.21           |
| Energy              | \$0.02           | \$0.02           | \$0.02           | \$0.06           | \$0.02           | \$0.02           |
| Scrap               | \$0.90           | \$0.76           | \$0.70           | \$1.51           | \$1.33           | \$1.01           |
| Tooling             | \$0.03           | \$0.02           | \$0.02           | \$0.03           | \$0.03           | \$0.03           |
| <b>Part Total</b>   | <b>\$39.21</b>   | <b>\$34.87</b>   | <b>\$28.41</b>   | <b>\$64.97</b>   | <b>\$57.91</b>   | <b>\$46.61</b>   |
| Stack Count         | 85               | 85               | 85               | 106              | 106              | 106              |
| Stack Total         | \$3,333.02       | \$2,964.12       | \$2,415.11       | \$6,886.82       | \$6,138.35       | \$4,940.77       |
| <b>Capital Cost</b> | <b>\$434,685</b> | <b>\$434,685</b> | <b>\$869,370</b> | <b>\$434,685</b> | <b>\$434,685</b> | <b>\$869,370</b> |

**Table 5-7. MEA Material Cost Summary**

| Material                   | 10 KW          |                |                | 25 kW          |                |                |
|----------------------------|----------------|----------------|----------------|----------------|----------------|----------------|
|                            | 100            | 1000           | 10000          | 100            | 1000           | 10000          |
| Catalyst                   | \$19.48        | \$18.27        | \$14.67        | \$32.39        | \$30.39        | \$24.14        |
| Membrane                   | \$10.24        | \$9.17         | \$7.37         | \$17.02        | \$15.25        | \$12.26        |
| GDL                        | \$7.78         | \$5.90         | \$4.91         | \$12.94        | \$9.81         | \$8.17         |
| Transfer Substrate         | \$0.21         | \$0.21         | \$0.21         | \$0.34         | \$0.34         | \$0.34         |
| <b>Total Material Cost</b> | <b>\$37.70</b> | <b>\$33.55</b> | <b>\$27.16</b> | <b>\$62.69</b> | <b>\$55.79</b> | <b>\$44.91</b> |

### 5.1.5 Stack Assembly

The stack components are assembled as shown. Pressure is applied to the completed stack using a hydraulic press, and the tie rods are installed to complete the stack assembly. Tie rod costs were assumed to be \$40.00 per stack. Base stack assembly costs were assumed to be \$50.32 for the 10 kW stack and \$52.47 for the 25 kW stack. After applying learning curve analysis, the average stack assembly costs were calculated as shown in Table 5-8.

**Table 5-8. Stack Assembly Costs**

|               | 10 kW   |         |         | 25 kW   |         |         |
|---------------|---------|---------|---------|---------|---------|---------|
|               | 100     | 1000    | 10000   | 100     | 1000    | 10000   |
| Assembly Cost | \$64.82 | \$51.87 | \$50.46 | \$67.59 | \$53.98 | \$52.62 |

Figure 5-1 shows the manufacturing process in flow chart format.

## 5.2 Electrical System Cost Assumptions

The cost for the electrical system is primarily driven by the DC/DC converter and the lithium ion battery. The system controller and sensor feedback items comprise the next largest amount of the cost while the protective devices and interconnecting components complete the remainder of the total cost.

### 5.2.1 DC/DC Converter

The DC/DC converter cost for the 10 kW system is an averaged cost at each quantity of the converter estimates obtained for that system. The 25 kW converter costs use the 10 kW numbers and apply a scale factor of two. This approach was used because the converters can be connected in parallel to obtain higher output power. A factor of two was applied rather than 2.5 because the higher number of converters used to produce a single system drives down the cost per system and the converters used in the estimation were capable of more than 10 kW.

The cost of power conversion products is based largely on production volumes. The primary components in a buck converter are circuit card assemblies (CCAs), an inductor, power transistors, bulk storage capacitors, control and communication circuitry, packaging and heat transfer components (finned heat sinks or liquid cooling plates). Because the voltage used in material handling applications is relatively low, the current levels are quite large (typically hundreds of amps). High current converter designs usually implement one of two approaches, several smaller converters working together in parallel or one large converter. The tradeoffs for this decision are usually dictated by the required voltages and power, availability of components in the voltage and current ranges required, and cost. At high current levels, the copper plating thickness of the traces on the printed wiring board (PWB) typically drives up the cost of the PWB that houses the power circuitry. The cost of the inductors, power transistors, and integrated circuits (ICs) used for the design are based solely on quantity and component selection. Manufacturing costs are based on quantity at the unit level. At present there is not a high demand for DC-DC converters that are used in material handling applications. Some ways to potentially reduce the cost of DC-DC converters would be to leverage similar products used by other industries that are produced in mass and to

refine manufacturing processes that reduce cost. Another factor that increases the cost of the converter in this application is the need to interface with the fuel cell and the batteries.

Based on the research conducted, there do not appear to be any manufacturers that produce DC-DC converters of this type in mass quantities. If the demand for these converters were present, competition would increase and the economy of scale would likely drive cost down some at high quantities; however, 10,000 units may not be a large enough number to justify large cost savings. But, the fact remains that the individual components used in DC-DC converter designs requiring high current are not cheap and to some extent are dependent on the market value of the raw materials. For example, copper is used in large amounts because of the high current inherent to material handling applications (low voltage, high power) so the cost of PWB plating, connectors, wire and cable, power transistors, etc. will fluctuate with the cost of the raw material.

### **5.2.2 Battery**

The cost of the lithium ion battery was also an average cost of multiple vendor estimates. The battery manufacturers provided cost estimates only, not price quotes; however, these estimates were based on similar previously designed battery systems. In general, manufactures made a point to comment that each battery pack is unique and as such specific design requirements and guidelines must be provided before an official quote on the cost could be obtained. The development of detailed requirements for a battery pack was outside of the scope of this effort.

The battery for the system was sized and estimated based on the need for peak power requirements of three times the maximum fuel cell power. It also considered the cost for a battery management system, safety features, and the ability to communicate the state of health of the battery to and external controller. The 10 kW battery estimate was multiplied by a factor of 2 for the 25 kW system for reasons similar to the DC/DC converter.

It is important to note that lithium ion batteries are generally more expensive than other battery technologies. This cost is the result of several factors including material cost, manufacturing costs, control circuitry, protection components, module and pack level packaging complexity, and additional required features such as cooling assemblies. The following table is a breakdown of cost from a CGGC study performed in 2009 on the production of 100,000 25 kWh electric vehicle packs<sup>17</sup>. While the pack size, quantities, and the trade-offs when designing a lithium ion battery for an electric vehicle are different than for a material handling fuel cell, hybrid application, the cost breakdown serves as a reasonable representation of the major cost contributors in a lithium ion battery pack.

---

<sup>17</sup> Lowe, Marcy et al. "Lithium-ion Batteries for Electric Vehicles: The U.S. Value Chain," Center on Globalization Governance & Competitiveness. 10/5/10. [http://unstats.un.org/unsd/trade/s\\_geneva2011/refdocs/RDs/Lithium-Ion%20Batteries%20\(Gereffi%20-%20May%202010\).pdf](http://unstats.un.org/unsd/trade/s_geneva2011/refdocs/RDs/Lithium-Ion%20Batteries%20(Gereffi%20-%20May%202010).pdf)

**Table 5-9. Lithium-Ion Battery Cost Breakdown**

|                        | Components                         | \$/EV Battery | Cost Breakdown |
|------------------------|------------------------------------|---------------|----------------|
| <b>Cell Components</b> | Cathode                            | 1,663         | 10%            |
|                        | Anode                              | 477           | 3%             |
|                        | Electrolyte                        | 447           | 3%             |
|                        | Copper Foil                        | 184           | 1%             |
|                        | Separator                          | 608           | 4%             |
|                        | Can Header and Terminals           | 1,050         | 6%             |
|                        | Other Materials                    | 375           | 2%             |
|                        | <b>Total Material</b>              | <b>4,803</b>  | <b>29%</b>     |
| <b>Cells</b>           | Labor for Cell Manufacturing       | 2,586         | 16%            |
|                        | <b>Total Cell</b>                  | <b>7,390</b>  | <b>45%</b>     |
| <b>Electronics</b>     | Mechanical Components              | 2,053         | 12%            |
|                        | Electrical Components              | 299           | 2%             |
|                        | Electronics (battery mgmt. system) | 1,381         | 8%             |
|                        | <b>Total Electronics</b>           | <b>3,733</b>  | <b>22%</b>     |
| <b>Packs</b>           | Labor for Pack Manufacturing       | 268           | 2%             |
|                        | <b>Total Packs</b>                 | <b>11,390</b> | <b>69%</b>     |
| <b>Warranty</b>        |                                    | <b>228</b>    | <b>1%</b>      |
| <b>Gross Profit</b>    |                                    | <b>4,979</b>  | <b>30%</b>     |
| <b>Total Cost</b>      |                                    | <b>16,596</b> | <b>100%</b>    |

### 5.2.3 Controller and Sensors

The system controller cost was estimated based on previous efforts completed here at Battelle and OEM automotive ECU cost. The assumption is that the system controller is a custom circuit card assembly built around a micro-controller that handles the specific needs of the system. It was also assumed that because of the similarity to an automotive system ECU, the system controller might have some of the same features as an automotive ECU and as such the cost of OEM ECUs was used to estimate the higher quantity cost of the controller. The current sensor and voltage sense circuitry are readily available components and as a result the cost for those components could be identified via the internet. The cost for the hydrogen sensor was also found on the internet, but hydrogen detection sensors designed specifically for this application (simple and affordable threshold detectors) were difficult to identify. As a result, the cost for the hydrogen sensors reflects a single vendors cost.

### 5.2.4 Protection and Interconnects

The contactors and fuses used in material handling applications typically require high current and low DC voltage ratings. The manufacturers that supply these types of devices are somewhat limited. The cost of these components is an average of the component costs obtained from the internet and quoted prices from authorized distributors of the products. The power connector used to connect the system was assumed to be an Anderson style connector and the costs reflect the average cost of that component in the appropriate amperage rating. It was assumed that busbar is required because of the volume constraints in the system. The busbar is used to connect the fuel cell output to the DC/DC converter and the battery. The price for the busbar used a length of 2 ft and it does not reflect the cost to machine (bend, drill, tap, etc.) the bar for

the application. The cost for the connectors and other interconnection cable was estimated based on figures from the Battelle 2011 report.<sup>18</sup>

### **5.3 Balance of Plant Cost Assumptions**

The costs associated with the BOP components are tabulated in Table 5-10 and Table 5-11. Figures 5-2 and 5-3 compare component costs at a subcategory level similar to the system schematic. At a production rate of 1,000 systems a year, the BOP hardware is estimated to cost nearly \$21,100 for one 10 kW system and \$34,600 for 25 kW.

A category titled “Additional Work Estimate” is included to capture any small realized or unrealized contingencies not specifically itemized in this report. This includes components such as heat sinks and fans for additional electrical cooling, supplementary temperature or pressure sensors, and any extra assembly hardware. This estimate was developed around a 20% buffer to the electrical subsystem cost, not including the battery, and a 10% buffer to all remaining hardware except the hydrogen tank.

---

<sup>18</sup> Battelle. 2011. The High Volume Manufacture Cost Analysis of 5 KW Direct Hydrogen Polymer Electrolyte (PEM) Membrane Fuel Cell for Backup Power Applications. Report to the DOE. DOE Contract No. DE-FC36-03GO13110.

**Table 5-10. Component Costs for the 10 kW MHE System**

| Component Description                   | Annual Production of 10 kW PEM Systems |                 |                 |                 |
|---|--|-----------------|-----------------|-----------------|
|   | (1)                                    | (100)           | (1,000)         | (10,000)        |
| Tank Fill Port                          | \$235                                  | \$212           | \$190           | \$171           |
| Hydrogen Tank                           | \$4,000                                | \$3,494         | \$3,373         | \$3,373         |
| Tank Pressure Sensor                    | \$545                                  | \$445           | \$430           | \$405           |
| Tank Manual Valve                       | \$305                                  | \$225           | \$210           | \$200           |
| Hydrogen Regulator                      | \$1,500                                | \$1,400         | \$1,200         | \$1,000         |
| Tank Solenoid Valve (Shutoff)           | \$91                                   | \$71            | \$65            | \$63            |
| Stack Anode Pressure Sensor             | \$395                                  | \$375           | \$375           | \$375           |
| Relief Valve                            | \$175                                  | \$155           | \$150           | \$150           |
| H2 Recirc Blower & Controller           | \$1,875                                | \$1,595         | \$469           | \$431           |
| Purge Valve                             | \$105                                  | \$92            | \$78            | \$72            |
| Filter & Housing (Cathode Air)          | \$313                                  | \$215           | \$166           | \$134           |
| Blower (Cathode Air)                    | \$838                                  | \$629           | \$503           | \$440           |
| Humidifier                              | \$1,640                                | \$1,595         | \$1,276         | \$1,085         |
| Flow meter (Cathode Air)                | \$123                                  | \$112           | \$100           | \$94            |
| Pump (Coolant Water)                    | \$260                                  | \$240           | \$195           | \$190           |
| Radiator                                | \$850                                  | \$625           | \$500           | \$425           |
| Deionization Filter                     | \$82                                   | \$63            | \$54            | \$43            |
| DC/DC Converter (Power)                 | \$4,000                                | \$3,450         | \$2,900         | \$1,996         |
| Battery                                 | \$10,333                               | \$8,500         | \$6,000         | \$5,000         |
| Fuel Cell Electronic Control Unit (ECU) | \$800                                  | \$500           | \$300           | \$175           |
| System Controller                       | \$800                                  | \$500           | \$300           | \$175           |
| Bus Bar                                 | \$32                                   | \$17            | \$16            | \$14            |
| Fuses                                   | \$38                                   | \$37            | \$37            | \$36            |
| DC/DC Converter (Controls)              | \$84                                   | \$76            | \$72            | \$68            |
| Connector Power                         | \$30                                   | \$24            | \$21            | \$18            |
| Contactors                              | \$100                                  | \$72            | \$64            | \$60            |
| Temperature Sensors                     | \$125                                  | \$95            | \$55            | \$40            |
| Current Sensor                          | \$32                                   | \$14            | \$11            | \$9             |
| Voltage Sensor                          | \$55                                   | \$50            | \$43            | \$39            |
| H2 Sensor                               | \$176                                  | \$132           | \$106           | \$97            |
| Assorted Plumbing/Fittings              | \$180                                  | \$165           | \$150           | \$135           |
| Wiring & Connectors                     | \$58                                   | \$55            | \$50            | \$45            |
| Assembly Hardware                       | \$35                                   | \$33            | \$30            | \$27            |
| Frame & Housing                         | \$219                                  | \$209           | \$190           | \$171           |
| Additional Work Estimate                | \$2,200                                | \$1,800         | \$1,400         | \$1,100         |
| <b>Total Cost</b>                       | <b>\$32,629</b>                        | <b>\$27,272</b> | <b>\$21,079</b> | <b>\$17,856</b> |



**Table 5-11. Component Costs for the 25 kW System**

| Component Description          | Annual Production of 25 kW PEM Systems |                 |                 |                 |
|--------------------------------|--|-----------------|-----------------|-----------------|
|                                | (1)                                    | (100)           | (1,000)         | (10,000)        |
| Tank Fill Port                 | \$235                                  | \$212           | \$190           | \$171           |
| Hydrogen Tank                  | \$4,000                                | \$3,494         | \$3,373         | \$3,373         |
| Tank Pressure Sensor           | \$545                                  | \$445           | \$430           | \$405           |
| Tank Manual Valve              | \$305                                  | \$225           | \$210           | \$200           |
| Hydrogen Regulator             | \$1,500                                | \$1,400         | \$1,200         | \$1,000         |
| Tank Solenoid Valve (Shutoff)  | \$91                                   | \$71            | \$65            | \$63            |
| Stack Anode Pressure Sensor    | \$395                                  | \$375           | \$375           | \$375           |
| Relief Valve                   | \$175                                  | \$155           | \$150           | \$150           |
| H2 Recirc Blower & Controller  | \$1,875                                | \$1,595         | \$469           | \$431           |
| Purge Valve                    | \$105                                  | \$92            | \$78            | \$72            |
| Filter & Housing (Cathode Air) | \$313                                  | \$215           | \$166           | \$134           |
| Blower (Cathode Air)           | \$1,680                                | \$1,260         | \$1,010         | \$885           |
| Humidifier                     | \$2,630                                | \$2,500         | \$2,000         | \$1,700         |
| Flow meter (Cathode Air)       | \$123                                  | \$112           | \$100           | \$94            |
| Pump (Coolant Water)           | \$336                                  | \$314           | \$251           | \$213           |
| Radiator                       | \$840                                  | \$750           | \$591           | \$503           |
| Deionization Filter            | \$163                                  | \$127           | \$108           | \$86            |
| DC/DC Converter (Power)        | \$10,872                               | \$8,915         | \$7,718         | \$6,024         |
| Battery                        | \$20,667                               | \$17,000        | \$12,000        | \$10,000        |
| Fuel Cell ECU                  | \$800                                  | \$500           | \$300           | \$175           |
| System Controller              | \$800                                  | \$500           | \$300           | \$175           |
| Bus Bar                        | \$64                                   | \$50            | \$47            | \$47            |
| Fuses                          | \$53                                   | \$48            | \$44            | \$39            |
| DC/DC Converter (Controls)     | \$84                                   | \$76            | \$72            | \$68            |
| Connector Power                | \$61                                   | \$49            | \$42            | \$35            |
| Contactors                     | \$210                                  | \$162           | \$127           | \$115           |
| Temperature Sensors            | \$125                                  | \$95            | \$55            | \$40            |
| Current Sensor                 | \$32                                   | \$14            | \$11            | \$9             |
| Voltage Sensor                 | \$55                                   | \$50            | \$43            | \$39            |
| H2 Sensor                      | \$176                                  | \$132           | \$106           | \$97            |
| Assorted Plumbing/Fittings     | \$180                                  | \$165           | \$150           | \$135           |
| Wiring & Connectors            | \$58                                   | \$55            | \$50            | \$45            |
| Assembly Hardware              | \$35                                   | \$33            | \$30            | \$27            |
| Frame & Housing                | \$243                                  | \$231           | \$210           | \$189           |
| Additional Work Estimate       | \$3,800                                | \$3,100         | \$2,500         | \$2,000         |
| <b>TOTAL COST</b>              | <b>\$53,626</b>                        | <b>\$44,517</b> | <b>\$34,571</b> | <b>\$29,114</b> |

**(1,000) 10kW Units**

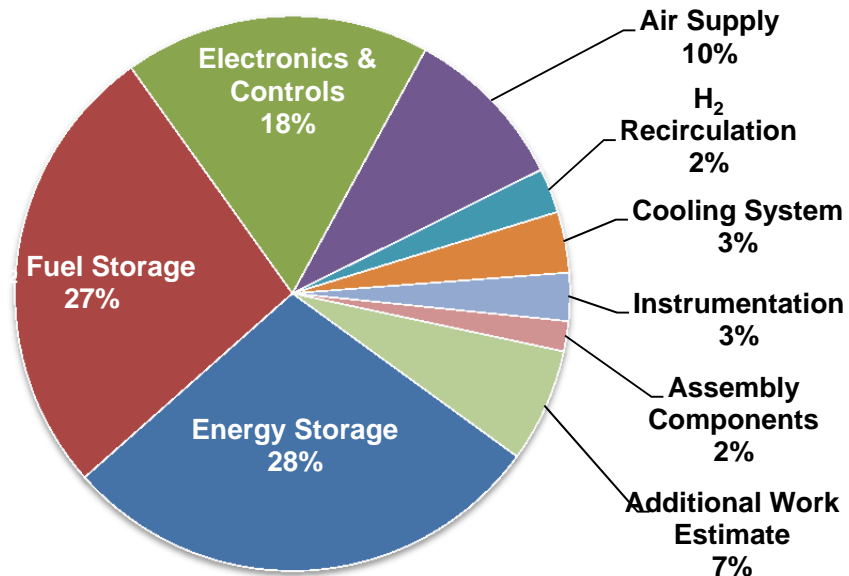

Figure 5-2. Distribution of Costs across Components for 10 kW Design.

**(1,000) 25kW Units**

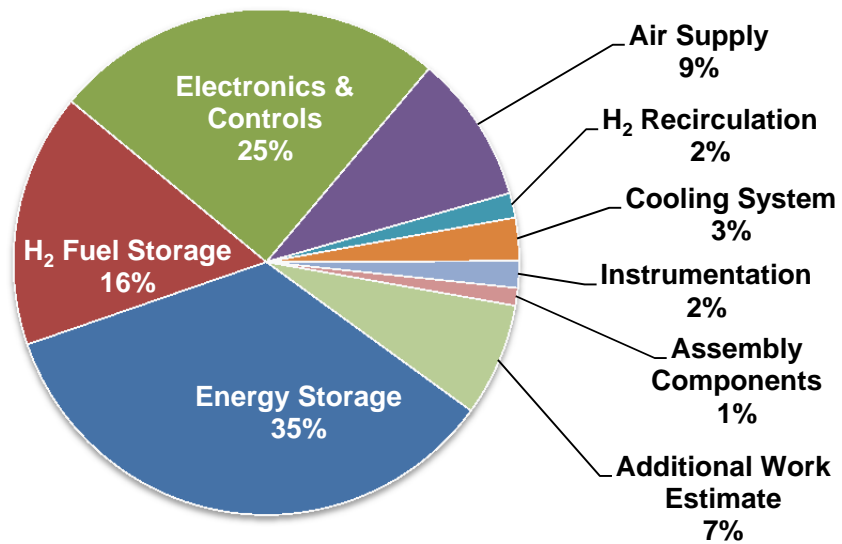

Figure 5-3. Distribution of Costs across Components for 25 kW Design.

### 5.3.1 Future Cost Reductions

Energy storage is by far the largest hardware expense to the balance of plant; the Li-ion battery storage alone accounts for 28–39% of the total BOP hardware cost depending on the annual production rate and system size. In general power pack manufacturers have designed packs that are constrained by volume and weight to match the characteristics of the lead acid battery they are replacing. If the forklift were designed with the fuel cell system in mind, more space could be allocated to accommodate different battery technologies.

The DC/DC converter is a substantial expense as well. Depending on the system analyzed and the annual production rate, the main power DC/DC converter accounted for 11–22% of the overall BOP hardware cost. Alternative electrical system designs exist that seek to simplify or reduce the component cost in the system by removing the DC/DC converter and directly connecting the fuel cell to the batteries. This approach eliminates the cost of the converter at the potential expense of more complicated battery management electronics, additional electronics to manage power flow, a more stringent battery selection, and possibly a more involved stack design.

Composite tanks were selected for the hydrogen storage as this is the industry trend. Hydrogen storage is among the top three most expensive components in the analyzed system schematic; electrical energy storage and DC/DC converters being the remaining two. The generic composite tank imposed a significant expense, costing 7–19% of the overall BOP hardware cost depending on the system and production rate.

Although it is not the trend, steel tanks are also sometimes used in fuel cell-powered MHE applications. Costing figures were obtained for hydrogen tanks comprised of chrome-moly steel that were rated DOT 3AA 6000/TC 3AAM. Values are available in Table 7-8. Both the 10 kW and 25 kW systems were modeled to utilize the same size tank as each other. While both composite and steel tanks are used in fuel cell-powered MHE applications, there is a known trend towards composite tanks. There are benefits and challenges to each solution. While steel tanks are significantly less expensive and inherently provide ballast, they reduce capacity for a given footprint due to the need for thick walls. The fuel-cell MHE industry is retro-fitting their existing equipment and as such, space and weight constraints are critical. At high production rates of 10,000 units a year, steel hydrogen tanks can save over \$2,600 compared to its composite equivalent. The effect on the entire BOP cost is shown in the following pie chart. Note that the supporting hardware (e.g. fill port, pressure sensor, valve, regulator, and relief valve) were assumed to be the same despite the different tank compositions.

**Table 5-12. Composite versus All-Steel Tank Costs**

| Component Description               | Annual Production Rate |                |                |                |
|-------------------------------------|------------------------|----------------|----------------|----------------|
|                                     | (1)                    | (100)          | (1,000)        | (10,000)       |
| <b>Composite H<sub>2</sub> Tank</b> | \$4,000                | \$3,494        | \$3,373        | \$3,373        |
| <b>All-Steel H<sub>2</sub> Tank</b> | \$846                  | \$804          | \$754          | \$731          |
| <b>Savings</b>                      | <b>\$3,154</b>         | <b>\$2,690</b> | <b>\$2,619</b> | <b>\$2,642</b> |

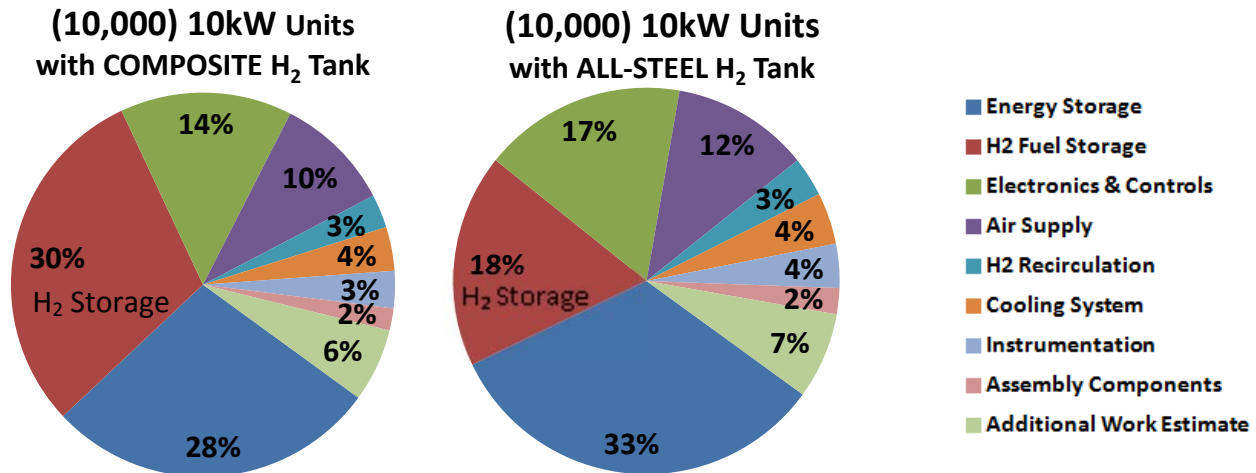

Figure 5-4. Variation in Balance of Plant Costs with Different Hydrogen Storage Systems

Material embrittlement and thermal expansion are a particular safety concern with hydrogen storage devices as well general robustness. Several vendors provide Type III and IV composite tanks that have undergone thorough testing and have been used in material handling applications. The majority of these tanks' construction is carbon fiber, which instantly escalates the price. It is important to also note that new composite tank designs requiring ISO accreditation induce a one-time fee of approximately \$30,000. Less expensive storage alternatives are being investigated and some are being employed in MHE units today. For example, tanks that are entirely steel can be 75% less expensive but have undergone significantly less regulated testing for this application. However, it is possible to properly design and manufacture a metal tank that is suitable for hydrogen fuel storage on a vehicle, which makes metal tanks a viable option to reduce cost. The metal tanks have another advantage in that they can provide critical ballast for the vehicle.

Cathode air humidification is another arena that imposes a large cost and is the focus of future cost reductions. Some membrane manufacturers are working to develop alternative material as a substitute for Nafion®, which could reduce the material cost as much as 30%. Early projections predict a prototype material to be finished this spring. Additionally, Gore and DuPont recently developed a new humidifier module that includes an alternative membrane material, which also shows potential of reducing the cost.<sup>19</sup> Often stack providers and integrators are working to decrease this expense themselves by developing their own proprietary humidifier or simply redesigning the system or stack to eliminate it all together.

## 5.4 System Assembly and Learning Curve Assumptions

The DFMA® software produces an assembly cost based on hand assembly at its most efficient, which is \$50.32 for the 10 kW stack, \$52.47 for the 25 kW stack, and \$44.94 for the rest of the system. The

<sup>19</sup> Johnson, William. "Materials and Modules for Low-Cost, High Performance Fuel Cell Humidifiers," W.L. Gore & Associates, Inc, Project ID FC067; 5/17/12.

learning curve analysis essentially backs that number up to a time when bugs are still being worked out of the assembly process. This additional time adds a slight cost to the base assembly cost. Total system assembly costs are summarized in Table 5-12, which includes a learning curve. Complete calculations are available in Appendix A-7.

**Table 5-123. Summary System Assembly Cost Assumptions**

| 1st Year Average Assembly Cost per Stack |                 |         |         |
|--|-----------------|---------|---------|
|  | Stacks per year |         |         |
|  | 100             | 1,000   | 10,000  |
| 10 kW Stack                              | \$64.82         | \$51.77 | \$50.46 |
| 25 kW Stack                              | \$67.59         | \$53.98 | \$52.62 |
| System                                   | \$57.89         | \$46.23 | \$45.07 |

## 5.5 Capital Cost Assumptions

The following table provides details on the cost assumptions for the components that make up the total capital cost.

**Table 5-14. Summary of Capital Cost Assumptions**

| Capital Cost                           | Unit Cost           | Units    | Total Cost (2010\$)            | Assumption/Reference   |
|--|---------------------|----------|--------------------------------|--|
| <b>Factory Total Construction Cost</b> | 250                 | \$/sq.ft | 855,750 to 5,545,000           | <ul style="list-style-type: none"> <li>Includes Electrical Costs (\$50/sq.ft.). Total plant area based on line footprint plus 1.5x line space for working space, offices, shipping, etc.</li> <li>Varies with anticipated annual production volumes of both 10 kW and 25 kW stacks.</li> </ul> |
| <b>Production Line Equipment Cost</b>  | Varies by component |          | 1,492,270 to 12,327,330        | <ul style="list-style-type: none"> <li>Varies with anticipated annual production volumes of both 10 kW and 25 kW stacks.</li> </ul>  |
| <b>Forklifts</b>                       | 25,000              | \$/lift  | 50,000                         | <ul style="list-style-type: none"> <li>Assumes 2 forklifts with extra battery and charger.</li> </ul>  |
| <b>Cranes</b>                          | 66,000              | \$/crane | 198,000                        | <ul style="list-style-type: none"> <li>5 ton crane, 20' wide per line</li> </ul>   |
| <b>Real Estate</b>                     | 125,000             | \$/acre  | 125,000                        | <ul style="list-style-type: none"> <li>Assumes 1 acre of vacant land, zoned industrial Columbus, OH</li> </ul>   |
| <b>Contingency</b>                     | 10% CC              |          | 272,102 to 1,871,833           | <ul style="list-style-type: none"> <li>Construction estimation assumption</li> </ul>   |
| <b>Total</b>                           |                     |          | <b>2,993,122 to 20,590,163</b> | <ul style="list-style-type: none"> <li>Varies with anticipated annual production volumes of both 10 kW and 25 kW stacks</li> </ul>   |

## 6 Limitations of the Analysis

The approach for the analysis is to create a generic system that is representative of current industry technology and practice. The generic system is made from the merged non-proprietary input from multiple industry representatives and is defined at a high level. There are numerous tradeoffs to be considered when choosing a specific design feature or system specification characteristic. Since the decisions made to define the design and specification are the basis for the cost analysis, it is worthwhile to explicitly consider the impact, limitations, and justification for the choices made.

### 6.1 Manufacturing Costs

Stack costs are based on the use of high-volume processes (i.e. roll-to-roll) for the construction of the MEA. These include catalyst deposition, decal transfer, and hot pressing. Individual MEA stack components are die cut following hot pressing. The assumption of roll-to-roll processes for low annual production volumes could result in artificially lower stack cost at these production levels.

Alternative and innovative manufacturing techniques were not evaluated. Based on industry feedback, the techniques used for the cost analysis are consistent with existing processes used by stack component manufacturers. One possible exception is the bipolar plates, where there is a split between the use of compression molded graphite composite material and stamped and coated metal material. Note that the graphite composite bipolar plates were chosen due to longevity concerns associated with the MHE application. In summary:

**Table 6-1. Manufacturing Processes Evaluated**

| Process                    | Method Evaluated                 | Alternatives not Evaluated  |
|----------------------------|----------------------------------|---|
| <b>Catalyst deposition</b> | Spray coating                    | <ul style="list-style-type: none"> <li>• Slot die coating</li> <li>• Tape casting</li> <li>• Nanostructure Thin Film</li> </ul> |
|                            | Single layer with decal transfer | <ul style="list-style-type: none"> <li>• Dual head slot die</li> </ul>  |
| <b>Bipolar plate</b>       | Compression molding              | <ul style="list-style-type: none"> <li>• Die stamping and coating</li> </ul>  |
| <b>MEA forming</b>         | Ruler blade die cutting          | <ul style="list-style-type: none"> <li>• Laser cutting</li> </ul>   |
| <b>Gasket forming</b>      | Ruler blade die cutting          | <ul style="list-style-type: none"> <li>• Laser cutting</li> <li>• Injection molding</li> </ul>                                  |

The cost analysis assumed that membrane and gas diffusion layer (GDL) materials were purchased in roll form. This could result in slightly higher stack cost compared to the use of in-house production of these materials. However, the membrane and GDL materials are manufactured using complex, highly specialized, multi-step processes (see DTI report “Mass Production Cost Estimation for Direct H<sub>2</sub> PEM Fuel Cell Systems for Automotive Applications: 2010 Update” for details). Consequently, start-up costs and quality issues of in-house production facilities could result in costs that are higher than the manufacturer’s purchase price.

## 6.2 Balance of Plant Hardware Costs

Balance of plant hardware costs are higher than anticipated by previous studies for two primary reasons. First, annual production volume increase from of 1,000 and 10,000 units did not generate a significant level of volume discount pricing for the highly specialized purchased parts like the lithium-ion battery and hydrogen tank. Second, previous automotive-based studies failed to account for the cost of hydrogen storage as well as electrical energy storage, which turned out to be major cost drivers for the system. The cost of hydrogen storage comprises as much as 6% of the total system cost at high annual production rates. The highest cost component driving the system cost is the lithium-ion battery, which contributes as much as 25% to the total system cost at high annual production rates.

## 7 Cost Analysis Results

This section presents the results of the three manufacturing volumes for 10 and 25 KW MHE PEM fuel cell systems, including fuel cell stack, BOP, as well as overall system costs.

### 7.1 10 kW Cost Analysis Results

The stack manufacturing costs for the 10 kW PEM fuel cell stack are broken down by component in Table 7-1. The major contributors to the stack costs are the bipolar plates and the MEA, contributing to 23% and 69% of the total stack cost respectively (based on 10,000 units). Figure 7.1 shows the distribution of costs of the stack.

The BOP costs for the 10 kW PEM fuel cell stack are broken down by component in Table 7-2. The major contributors to the stack costs are the battery, the hydrogen tank and the DC/DC Converter contributing to 28%, 19% and 11% of the total stack cost respectively (based on 10,000 units). Figure 7-2 shows the distribution of costs for the BOP for the 10 kW system including the battery and hydrogen storage. Figure 7-3 shows the distribution of BOP costs without the battery and hydrogen storage system.

The total system cost breakdown is shown in Table 7-3 showing that the BOP cost is the primary driver.

**Table 7-1. 10 kW MHE PEM Fuel Cell Stack Manufacturing Cost Summary**

| Stack Component       | 100 Units (\$) | 1000 Units (\$) | 10,000 Units (\$) |
|-----------------------|----------------|-----------------|-------------------|
| Bipolar plates        | 726            | 725             | 724               |
| MEA                   | 3,333          | 2,964           | 2,415             |
| Cooling gasket        | 139            | 139             | 139               |
| Tie rods and hardware | 40             | 40              | 40                |
| End plates            | 54             | 54              | 54                |
| Stack assembly        | 65             | 52              | 50                |

Note: All costs include manufacturing scrap

**10 kW Stack Costs**  
100 units/year

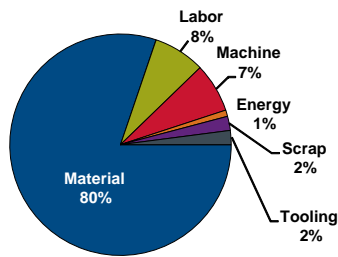

**10 kW Stack Costs**  
1000 units/year

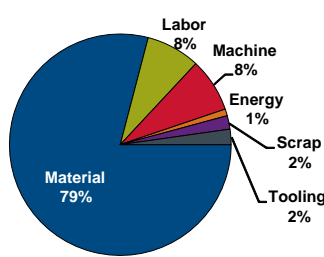

**10 kW Stack Costs**  
10,000 units/year

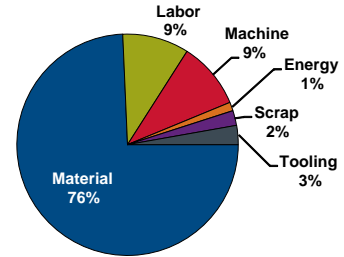

Figure 7-1. Cost Breakdown of 10 kW Stack

Table 7-2. 10 kW MHE PEM Fuel Cell BOP Manufacturing Cost Summary

| BOP Component                 | 100 Units (\$) | 1,000 Units (\$) | 10,000 Units (\$) |
|-------------------------------|----------------|------------------|-------------------|
| Battery                       | 8,500          | 6,000            | 5,000             |
| Hydrogen Tank                 | 3,494          | 3,373            | 3,373             |
| DC/DC Converter (Power)       | 3,450          | 2,900            | 1,996             |
| H2 Recirc Blower & Controller | 1,595          | 469              | 431               |
| Humidifier                    | 1,595          | 1,276            | 1,085             |
| Hydrogen Regulator            | 1,400          | 1,200            | 1,000             |
| Radiator                      | 625            | 500              | 425               |
| Blower (Cathode Air)          | 629            | 503              | 440               |
| Other Components              | 4,184          | 3,458            | 3,006             |
| Additional Work Estimate      | 1,800          | 1,400            | 1,100             |
| System Assembly               | 58             | 46               | 45                |

- Battery
- DC/DC Converter (Power)
- Hydrogen Tank
- Humidifier
- H2 Recirc Blower & Controller
- Hydrogen Regulator
- Blower (Cathode Air)
- Radiator
- Additional Work Estimate
- Other

**(100) 10kW Units**

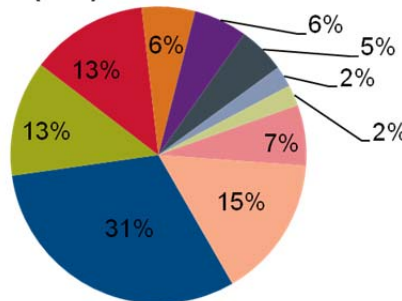

**(10,000) 10kW Units**

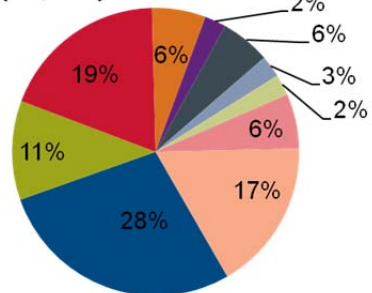
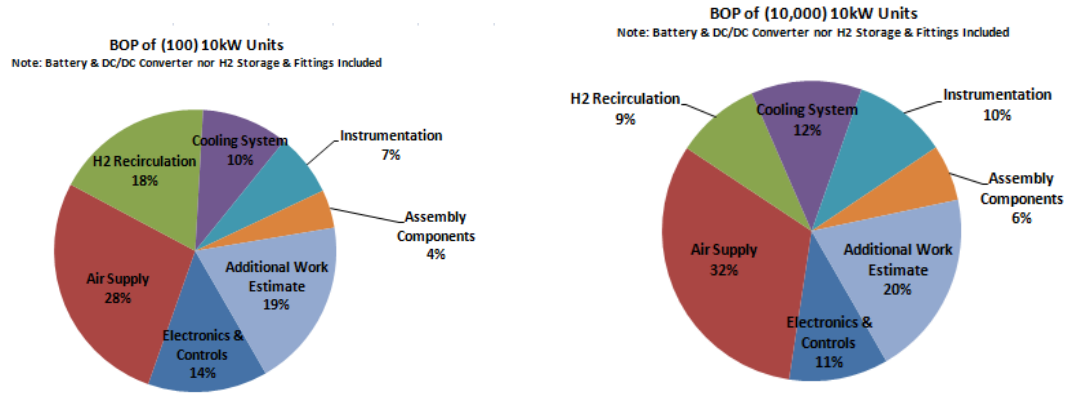

Figure 7-2. 10 kW MHE PEM Fuel Cell BOP Hardware Cost Breakdown (i.e. No System Assembly)





**Figure 7-3. 10 kW MHE PEM Fuel Cell BOP Hardware Cost Breakdown (i.e. No System Assembly) without Battery and Hydrogen Storage System**

**Table 7-3. 10 kW MHE PEM Fuel Cell System Cost Summary**

| Description                                | 100 Units       | 1,000 Units     | 10,000 Units    |
|--|-----------------|-----------------|-----------------|
| Total stack manufacturing cost, with scrap | \$4,357         | \$3,974         | \$3,422         |
| Stack manufacturing capital cost           | \$2,825         | \$283           | \$74            |
| <b>BOP</b>                                 | <b>\$27,272</b> | <b>\$21,079</b> | <b>\$17,856</b> |
| System assembly, test, and conditioning    | \$279           | \$267           | \$266           |
| Total system cost, pre-markup              | \$34,733        | \$25,603        | \$21,618        |
| System cost per gross KW, pre-markup       | \$3,158         | \$2,328         | \$1,965         |
| Sales markup                               | 50.0%           | 50.0%           | 50.0%           |
| Total system cost, with markup             | \$52,100        | \$38,405        | \$32,427        |
| System cost per gross KW, with markup      | \$4,736         | \$3,491         | \$2,948         |

## 7.2 25 kW Cost Analysis Results

The stack manufacturing costs for the 25 kW PEM fuel cell stack are broken down by component in Table 7-4. The major contributors to the stack costs are the bipolar plates and the MEA, contributing to 23% and 70% of the total stack cost respectively (based on 10,000 units). Figure 7.4 shows the distribution of costs of the stack.

The BOP costs for the 25 kW PEM fuel cell stack are broken down by component in Table 7-5. The major contributors to the stack costs are the battery, the hydrogen tank and the DC/DC Converter contributing to 33%, 21% and 12% of the total stack cost respectively (based on 10,000 units). Figure 7-5 shows the distribution of BOP costs with the battery and hydrogen storage system. Figure 7-6 shows the distribution of BOP costs without the battery and hydrogen storage system.

The total system cost breakdown is shown in Table 7-6 showing that the BOP cost is the primary driver. The distribution of costs for the various production volumes are shown in

**Table 7-4. 25 kW MHE PEM Fuel Cell Stack Manufacturing Cost Summary**

| Stack Component       | 100 Units (\$) | 1000 Units (\$) | 10,000 Units (\$) |
|-----------------------|----------------|-----------------|-------------------|
| Bipolar plates        | 1,461          | 1,475           | 1,457             |
| MEA                   | 6,887          | 6,138           | 4,941             |
| Cooling gasket        | 280            | 280             | 280               |
| Tie rods and hardware | 40             | 40              | 40                |
| End plates            | 80             | 80              | 80                |
| Stack assembly        | 68             | 54              | 53                |

Note: All costs include manufacturing scrap

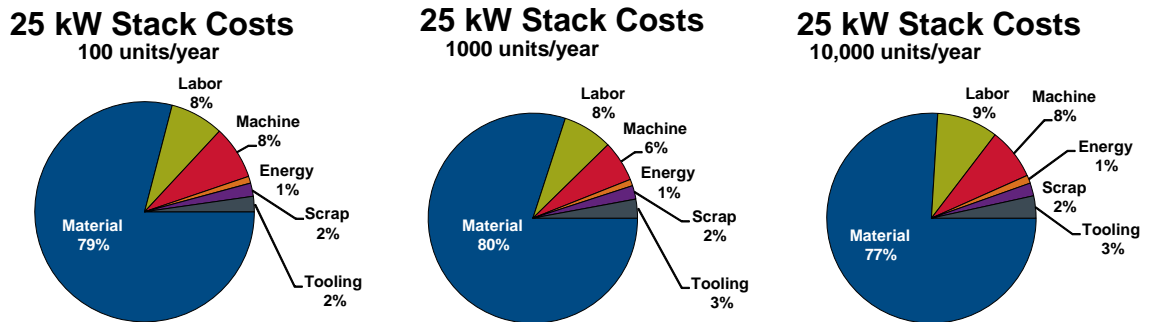

**Figure 7-4 Cost Breakdown of 25 kW Stack**

**Table 7-5. 25 kW MHE PEM Fuel Cell BOP Manufacturing Cost Summary**

| BOP Component                 | 100 Units (\$) | 1,000 Units (\$) | 10,000 Units (\$) |
|-------------------------------|----------------|------------------|-------------------|
| Battery                       | 17,000         | 12,000           | 10,000            |
| DC/DC Converter (Power)       | 8,915          | 7,718            | 6,024             |
| Hydrogen Tank                 | 3,494          | 3,373            | 3,373             |
| Humidifier                    | 2,500          | 2,000            | 1,700             |
| H2 Recirc Blower & Controller | 1,595          | 469              | 431               |
| Hydrogen Regulator            | 1,400          | 1,200            | 1,000             |
| Blower (Cathode Air)          | 1,260          | 1,010            | 885               |
| Radiator                      | 750            | 591              | 503               |
| Other Components              | 4,503          | 3,710            | 3,198             |
| Additional Work Estimate      | 3,100          | 2,500            | 2,000             |
| System Assembly               | 58             | 46               | 45                |

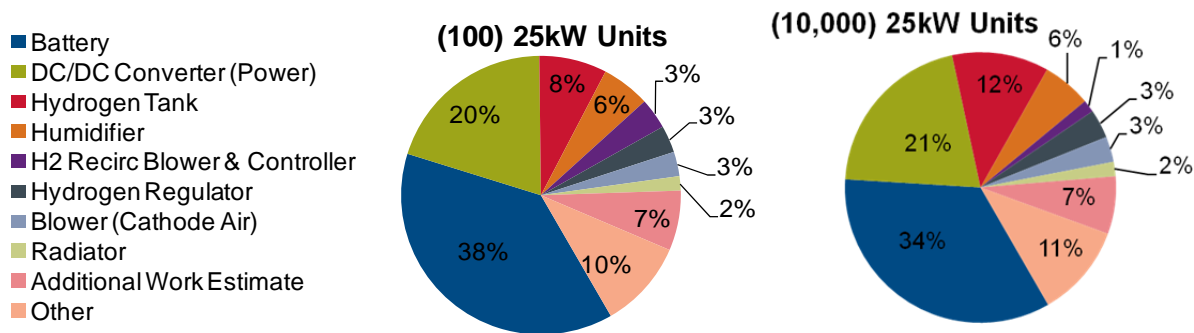

Figure 7-5. 25 kW MHE PEM Fuel Cell BOP Hardware Cost Breakdown (i.e. No System Assembly)

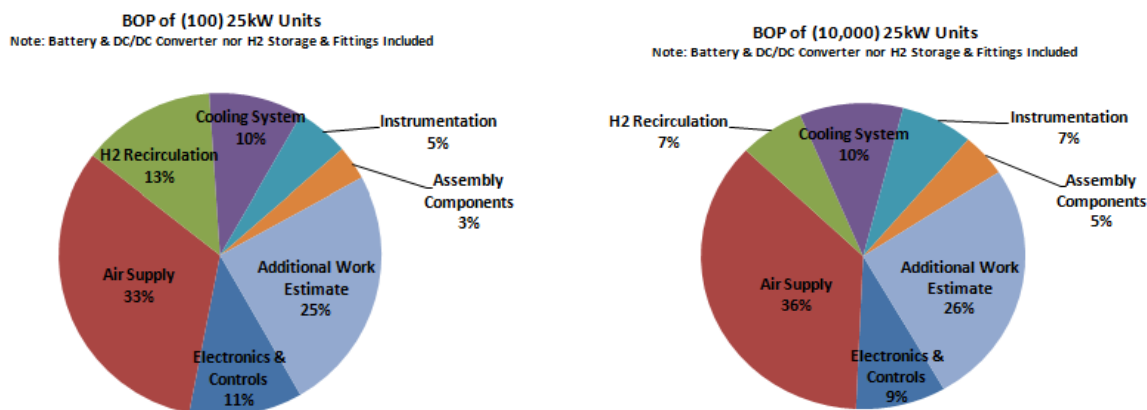

Figure 7-6. 25 kW MHE PEM Fuel Cell BOP Hardware Cost Breakdown (i.e. No System Assembly) Without Battery and Hydrogen Storage System

Table 7-6. 25 kW MHE PEM Fuel Cell System Cost Summary

| Description                                | 100 Units | 1,000 Units | 10,000 Units |
|--|-----------|-------------|--------------|
| Total stack manufacturing cost, with scrap | \$8,815   | \$8,068     | \$6,851      |
| Stack manufacturing capital cost           | \$2,825   | \$307       | \$121        |
| BOP  | \$44,517  | \$34,571    | \$29,114     |
| System assembly, test, and conditioning    | \$279     | \$267       | \$266        |
| Total system cost, pre-markup              | \$56,436  | \$43,213    | \$36,352     |
| System cost per gross KW, pre-markup       | \$2,052   | \$1,571     | \$1,322      |
| Sales markup                               | 50%       | 50%         | 50%          |
| Total system cost, with markup             | \$84,654  | \$64,820    | \$54,528     |
| System cost per gross KW, with markup      | \$3,079   | \$2,357     | \$1,983      |

## 8 Sensitivity Analysis

The sensitivity analysis of the costs for a 10 kW and 25 kW stack at the 10,000 unit production volume explores the impact of slight variations to the assumptions for the major contributing cost factors and highlights their significance. The cost factors for the analysis were chosen because of their significant

contribution to the cost and/or the difficult nature of precisely assessing their magnitude, such as the cost of platinum. The analysis demonstrates the effect to the overall cost of the stack based on reasonable variations to each factor. The results of the sensitivity analyses are shown in the following charts (Figures 8-1, 8-2), which show the relative importance of the major cost drivers.

The cost factors that were varied for the analysis include:

- Current Density
  - Assumed to be 1.0 A/cm<sup>2</sup>
  - Adjusted to 1.2 and 1.5 A/cm<sup>2</sup> to see effect
  - Adjusting current density generated the need to modify active area to keep the electrical system assumptions consistent
- Platinum Loading
  - Assumed to be 0.6 mg/cm<sup>2</sup>
  - Varied by + 0.1 mg/cm<sup>2</sup>, - 0.3 mg/cm<sup>2</sup>
- Platinum Cost
  - Assumed to be \$1,390 per troy ounce
  - Varied by +/- 20%
- Membrane Cost
  - Assumed to be \$180/m<sup>2</sup>
  - Varied by +/- 10%
- GDL Cost
  - Assumed to be \$60/m<sup>2</sup>
  - Varied by +/- 10%
- PFSA Cost
  - Assumed to be \$300/kg
  - Varied by +/- 10%
- Bipolar Plate Material Cost
  - Assumed to be \$2.43/kg
  - Varied by +/- 10%

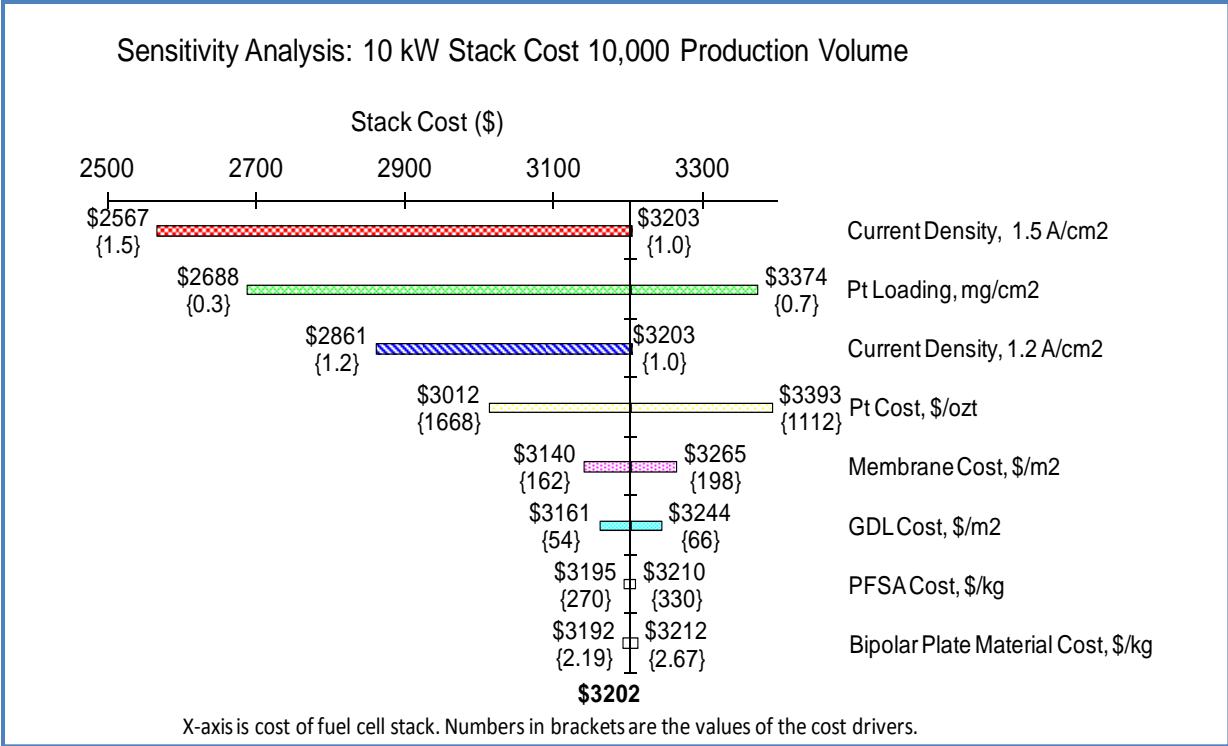

**Figure 8-1. Sensitivity Analysis: 10 kW Stack Cost – 10,000 Production Volume**

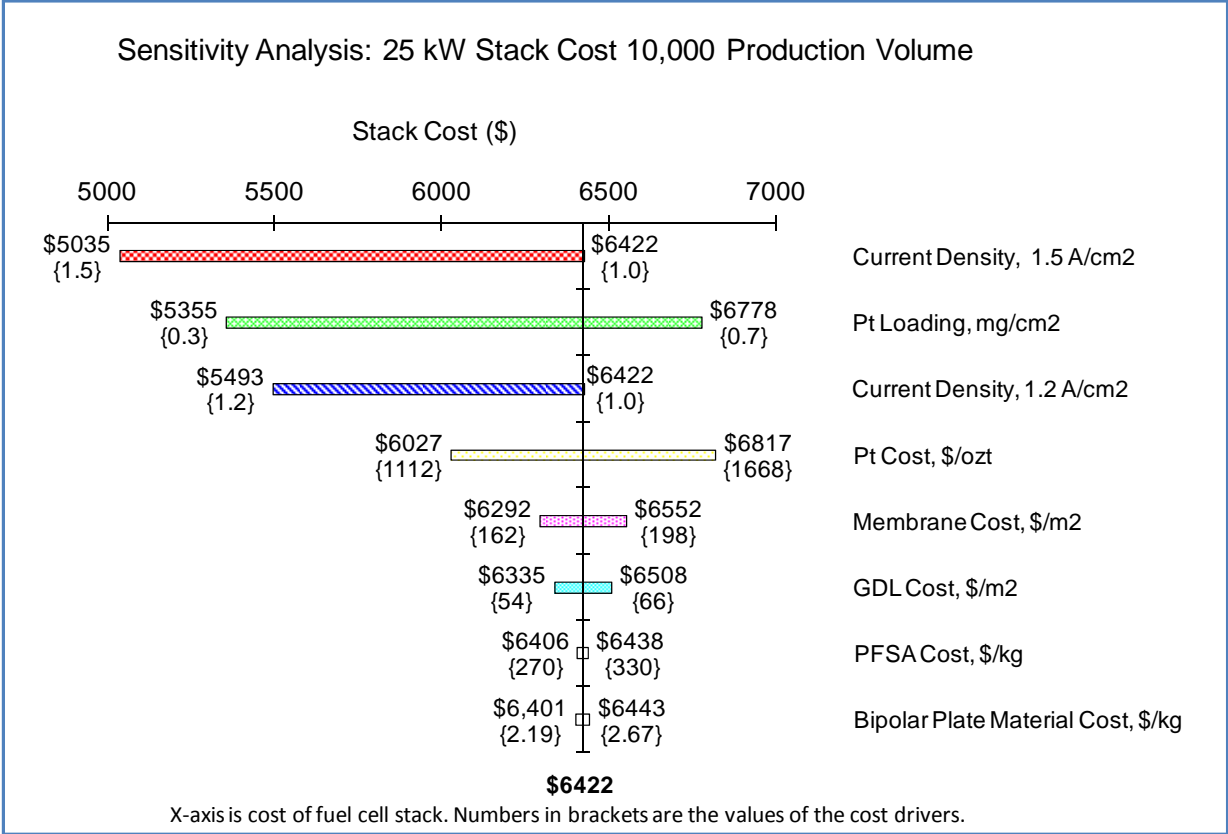

**Figure 8-2. Sensitivity Analysis: 25 kW Stack Cost – 10,000 Production Volume**

Current density and platinum loading are the two biggest factors affecting the cost of both the 10 kW and 25 kW stacks. The platinum loading used in the model (0.6 mg/cm<sup>2</sup>) is fairly conservative and stack producers are already pushing this down to save cost. The current density of 1.0 A/cm<sup>2</sup> is the state of the art currently, but likewise there is a trend for stack producers to begin to drive this higher. Current density and platinum loading need to be considered together as the platinum loading will affect what current density is achievable.

Platinum cost is somewhat of a wildcard and difficult to predict. For this analysis it was varied by +/- 20%, but potentially could vary even greater. This also contributes greatly to other factors such as the catalyst application scrap rate and platinum loading.

Material cost for the membrane, GDL, PFSA and bipolar plate material also need to be considered, but varying any of these by +/- 10% had little consequence on the overall stack cost. The membrane cost holds the most potential and could have a more significant impact if this could be lowered by even greater than 10%.

## 9 Lifecycle Cost Analysis of Fuel Cells

Fuel cell systems will compete with battery powered systems and internal combustion engine systems for application in warehousing operations. Fuel cell forklifts offer a number of advantages over conventional technologies including increased productivity, reduced maintenance, environmental benefits, and cost savings from reduced battery infrastructure. However, fuel cell systems continue to have a higher first cost than conventional alternatives.

This analysis looks to compare the lifecycle costs of fuel cell powered systems to battery systems for Class I/II forklifts to identify the biggest cost drivers. The analysis is based on Battelle's analysis of the manufacturing costs of the fuel cell system without markup. The characteristics of operation are based on the early market validation projects conducted by the DOE at various Defense Logistics Agency warehouses.<sup>20</sup> In this scenario, the early market deployment tests at warehousing operations operate 2 shifts a day for approximately 8.8 hours of operation per day. Based on a fuel cell life of 10,000 hours, the fuel cell and battery are replaced every three years. The \$8 per kg cost of hydrogen used in this analysis assumes that storage and delivery costs are amortized in the hydrogen cost. A discount rate of 8% and an inflation rate of 1.9% are applied. No disposal costs are assumed for any of the technologies. It is assumed that disposal costs are included in the initial capital cost of the system or that manufacturers allow trade-in of old systems. Assumptions are shown in Table 9-1.

---

<sup>20</sup> Information on DOE Early Market Deployments are available at [http://www.nrel.gov/hydrogen/proj\\_fc\\_market\\_demo.html#publications](http://www.nrel.gov/hydrogen/proj_fc_market_demo.html#publications).

**Table 9-1. Cost Assumptions for Fuel Cell Forklift and Battery Powered Forklift for 2 Shift Operations for Approximately 9 hours Per Day.**

|  | Fuel Cell           | Battery                                     |
|--|---------------------|---|
| Cost of Forklift Only (\$)                           | 25,000              | 25,000                                      |
| Cost of Power System (\$)                            | 35,000              | 5000 (each forklift has 2 batteries)        |
| Hours of Operation per Year (Hrs)                    | 3,000               | 3000  |
| Total Number of Shifts                               | 2                   | 2   |
| Hours per Shift                                      | 4.4                 | 4.4   |
| Average Operating Time w/o Refueling/Recharging      | 7.5                 | 4   |
| Time for Refueling (min)                             | 3.3                 | -   |
| Time for Changing out Batteries (min)                | -                   | 30  |
| Costs of Battery Charging Infrastructure (per Truck) | -                   | 2500  |
| Number of Times Refueled/Battery Changed             | 2                   | 2   |
| Cost of Refueling/Recharging (\$)                    | 612 <sup>a</sup>    | 5100  |
| Electricity/Hydrogen Fuel Costs                      | 4800 <sup>b</sup>   | 980 <sup>c</sup>                            |
| Replacement Costs Every 3 Years (\$)                 | 15,600 <sup>d</sup> | 5000 (X 2 as each forklift has 2 batteries) |

- a. Assumes operator cost of \$15/hr. Refuel the fuel cell twice. Replace the battery twice
- b. Assumes that truck uses 0.2 kg/operational hour. Operates for 3000 hours. Cost of hydrogen is \$8 per kg.
- c. Assumes electricity use is ~3kWh, batteries are charged for 8 hours. Two batteries are replaced every day, 340 days a year.
- d. Replacing only fuel cell stack and battery pack. Based on cost of manufacturing 10 kW fuel cell stack.

The results of these analysis are different from the earlier analysis performed by Battelle in 2007. The primary differences are – 1) capital cost of fuel cell is higher (approximately 50%) as this is based on the cost of manufacturing Battelle’s system design at lower volumes, 2) does not take into account incentives or tax credits, 3) assumed a higher cost of hydrogen (\$8 per kg as opposed to \$5 per kg).

Under the current assumptions for 2 shift operations of 8.8 hours, the Net Present Value (NPV) of the total capital costs, operating costs, and total costs of the fuel cell system are higher than the battery-powered alternative. In higher use operations fuel cell systems continue to be more expensive that conventional alternatives on a capital cost basis however are more cost effective on an operations and maintenance basis.

In order to make fuel cells more competitive with alternatives for larger market penetration there is continued need to invest in research and development programs to bring down the cost of fuel cell systems.

**Table 9-2. Net Present Value Analysis of Fuel Cell and Battery Powered Forklifts for 2 Shift Operations for Approximately 9 hours Per Day.**

|                                       | Fuel Cell Powered Fork Lift | Battery Powered Forklift |
|---------------------------------------|-----------------------------|--------------------------|
| NPV of Capital Costs (\$)             | 95,407                      | 60,251                   |
| NPV of O&M Costs (\$)                 | 52,610                      | 59,104                   |
| NPV of Total Costs of the System (\$) | 148,017                     | 119,355                  |

**Table 9-3.. Net Present Value Analysis of Fuel Cell and Battery Powered Forklifts for 3 Shift Operations for Approximately 16 hours Per Day.**

|                                       | Fuel Cell Powered Fork Lift | Battery Powered Forklift* |
|---------------------------------------|-----------------------------|---------------------------|
| NPV of Capital Costs (\$)             | 95,407                      | 94,555                    |
| NPV of O&M Costs (\$)                 | 95,518                      | 124,535                   |
| NPV of Total Costs of the System (\$) | 190,925                     | 219,091                   |

\*Assumes four battery packs per truck with three change outs in a 16 hr shift (battery lifetime is about 4 hours).

## 10 Conclusions

This section provides a summary of the MHE fuel cell system costs and resulting conclusions.

### 10.1 System Cost Summary

A high level summary of the final costs is shown below and emphasizes that the balance of plant dominates the final cost; at most it is estimated to account for 84% of the final cost before markup at high production volumes. In all sizes and production rates analyzed, the balance of plant was responsible for no less than 75% of the pre-markup price. Overall the final cost is analyzed in four distinct categories: the capital cost of manufacturing equipment, the direct cost of material and assembly of the stack, the expense of balance of plant hardware, and the final cost of complete system assembly and testing it. Anticipated scrap is also captured in the stack manufacturing cost.

**Table 10-1. 10 kW MHE PEM Fuel Cell System per Unit Cost Summary**

| Description                                 | 100 Units       | 1000 Units      | 10,000 Units    |
|---|-----------------|-----------------|-----------------|
| Total stack manufacturing cost, with scrap  | \$4,357         | \$3,974         | \$3,422         |
| Stack manufacturing capital cost            | \$2,825         | \$283           | \$74            |
| Balance of plant                            | \$27,272        | \$21,079        | \$17,856        |
| System assembly, test, and conditioning     | \$279           | \$267           | \$266           |
| <b>Total system cost, pre-markup</b>        | <b>\$34,733</b> | <b>\$25,603</b> | <b>\$21,399</b> |
| <b>System cost per gross KW, pre-markup</b> | <b>\$3,158</b>  | <b>\$2,328</b>  | <b>\$1,945</b>  |
| Sales markup                                | 50.00%          | 50.00%          | 50.00%          |
| <b>Total system cost, with markup</b>       | <b>\$52,100</b> | <b>\$38,405</b> | <b>\$32,099</b> |



|                                       |         |         |         |
|---------------------------------------|---------|---------|---------|
| System cost per gross KW, with markup | \$4,736 | \$3,491 | \$2,918 |
|---------------------------------------|---------|---------|---------|

A sales markup of 50% was integrated at the end and is called out separately in Tables 10-1 and 10-2. At high production volumes, the final ticket price is estimated to be \$2,918 per kW for a 10 kW MHE PEM system. This price decreases nearly 33% per kW for a 25 kW system. For a visual representation of the cost breakdown pre-markup, refer to the concluding pie charts.

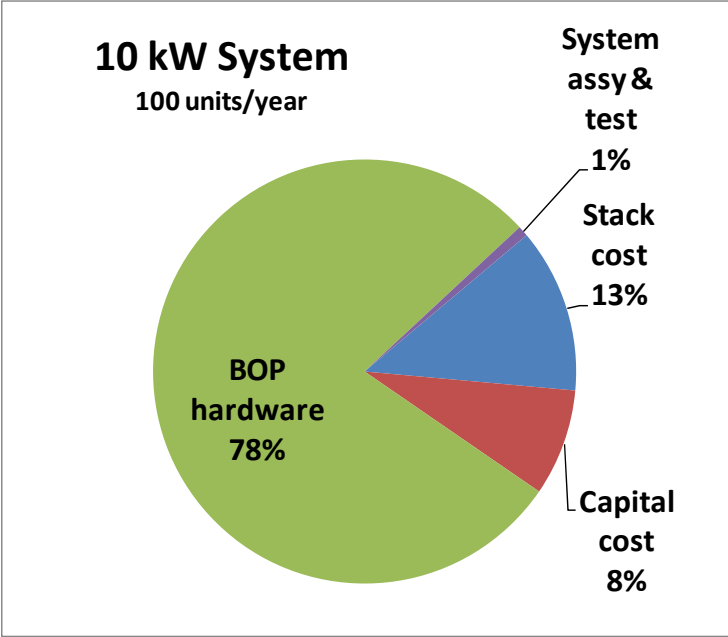

Figure 10-1. Distribution of Costs for 10 kW System (100 units/yr)

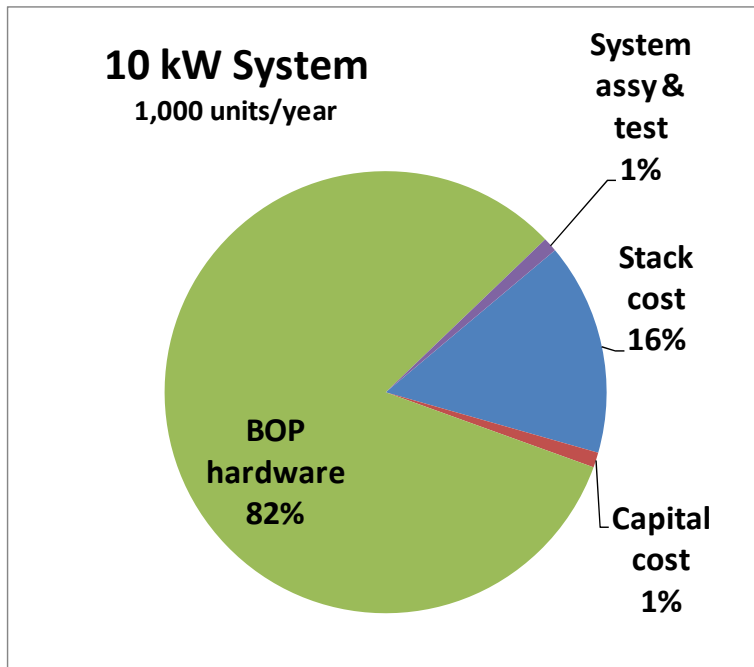

Figure 10-2. Distribution of Costs for 10 kW System (1,000 units/yr)

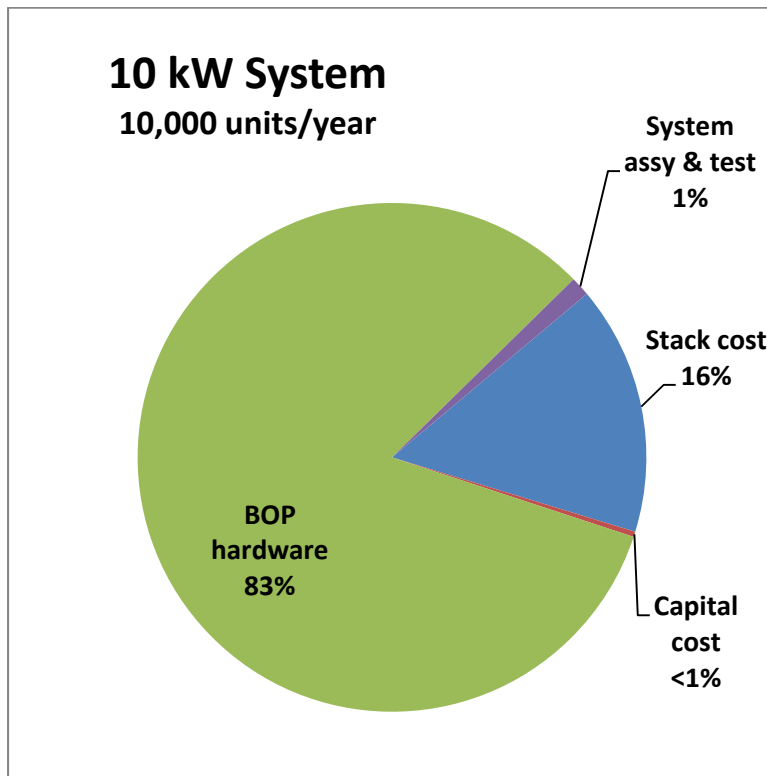
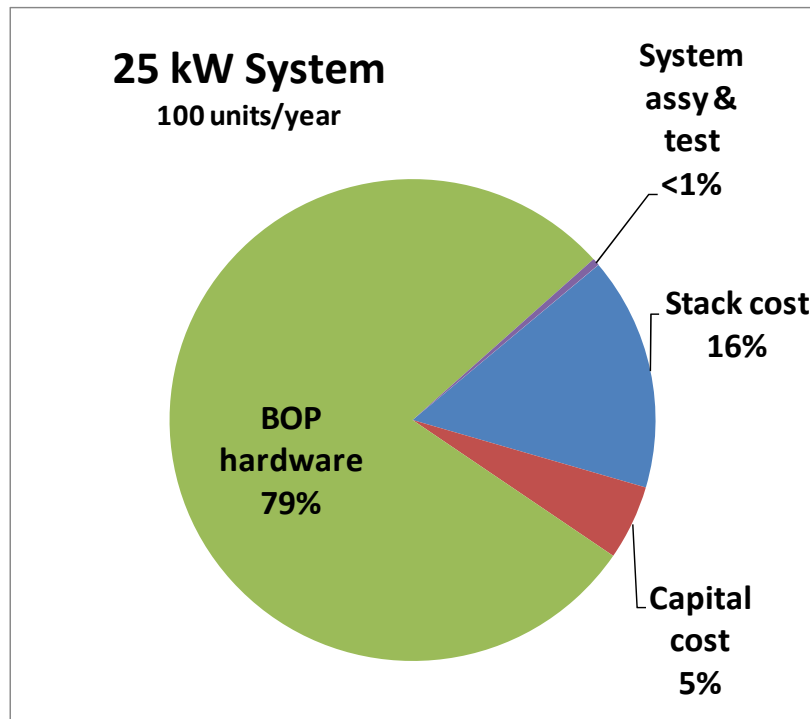

Figure 10-3. Distribution of Costs for 10 kW System (10,000 units/yr)

**Table 10-2. 25 kW MHE PEM Fuel Cell System Per Unit Cost Summary**

| Description                                  | 100 Units       | 1000 Units      | 10,000 Units    |
|--|-----------------|-----------------|-----------------|
| Total stack manufacturing cost, with scrap   | \$8,815         | \$8,068         | \$6,851         |
| Stack manufacturing capital cost             | \$2,825         | \$307           | \$121           |
| Balance of plant                             | \$44,517        | \$34,571        | \$29,114        |
| System assembly, test, and conditioning      | \$279           | \$267           | \$266           |
| <b>Total system cost, pre-markup</b>         | <b>\$56,436</b> | <b>\$43,213</b> | <b>\$35,923</b> |
| <b>System cost per gross KW, pre-markup</b>  | <b>\$2,052</b>  | <b>\$1,571</b>  | <b>\$1,306</b>  |
| Sales markup                                 | 50.00%          | 50.00%          | 50.00%          |
| <b>Total system cost, with markup</b>        | <b>\$84,654</b> | <b>\$64,820</b> | <b>\$53,885</b> |
| <b>System cost per gross KW, with markup</b> | <b>\$3,079</b>  | <b>\$2,357</b>  | <b>\$1,959</b>  |



**Figure 10-4. Distribution of Costs for 25 kW System (100 units/yr)**

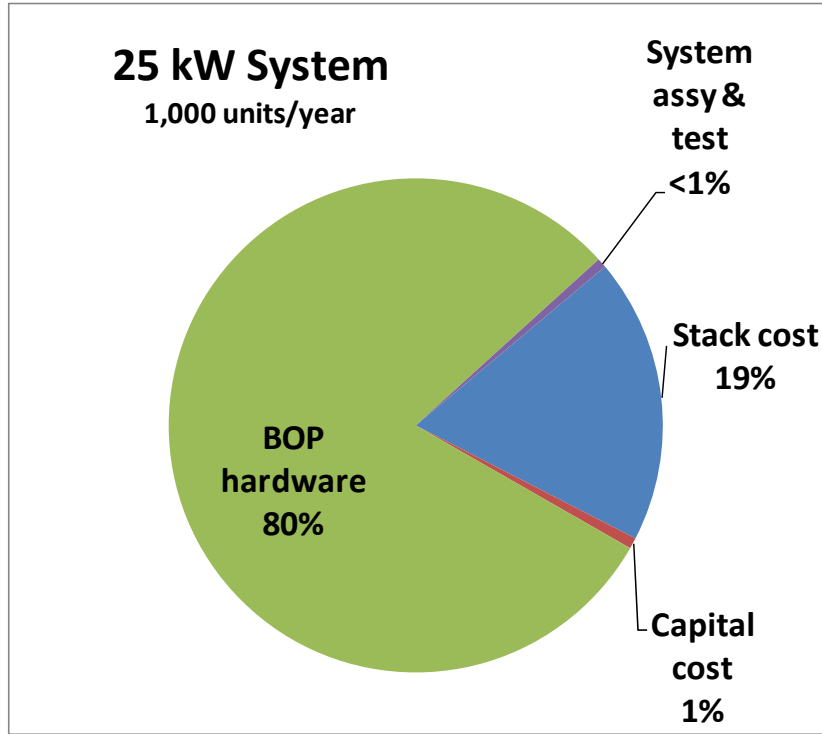

Figure 10-5. Distribution of Costs for 25 kW System (1,000 units/yr)

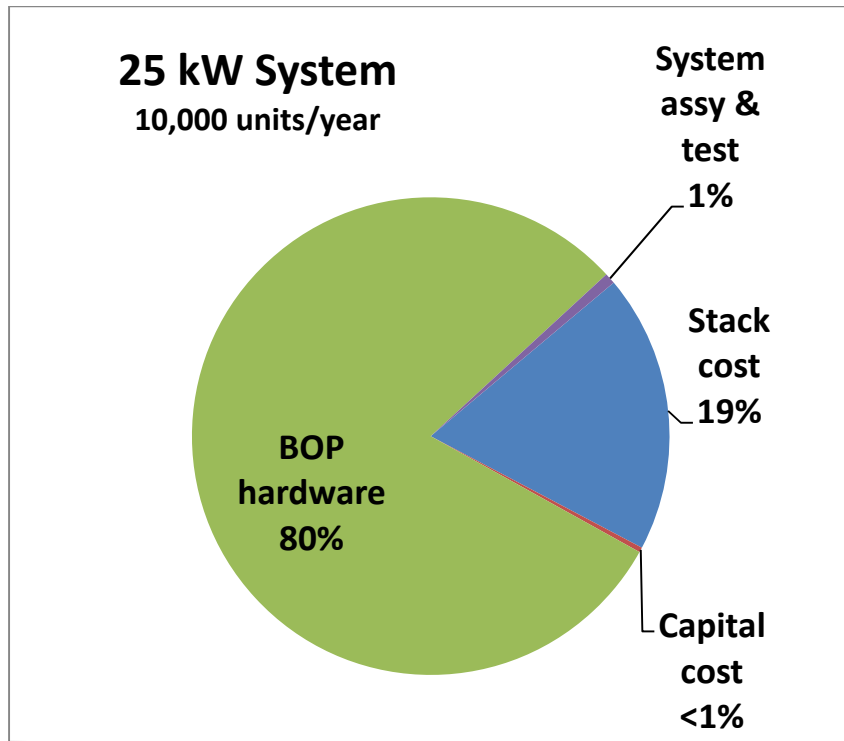

Figure 10-6. Distribution of Costs for 25 kW System (10,000 units/yr)

## 10.2 Results

The primary driver of overall MHE system cost is the cost of BOP hardware, with battery, DC/DC converter, hydrogen tank, and humidification system making up around 75% of the total BOP cost. The stack costs is most sensitive to change in current density and platinum loading.

Production volume considered in this report has negligible effect on stack cost, due to the fact that platinum, graphite composite bipolar plate material, and commodity material costs are fairly constant across the range of purchased material quantities. Platinum is generally purchased at market spot price. Commodity material (e.g., aluminum, carbon black, methanol) markets are generally mature with price points fairly level over all but the smallest purchase quantities.

The manufacturing costs are also constrained to a lower cost bound by the material processing requirements; i.e., regardless of the volume being produced, the time required to produce each part is the same. For example, the bipolar plate material requires at least 120 seconds cure time in the mold, and another 15 minutes of post-bake time. This places an upper limit on throughput, and a corresponding lower limit on manufacturing cost, which is a function of the machine time required in producing each part. The same production time constraints are applicable to MEA hot pressing, and to a lesser extent, to catalyst application.

# APPENDIX

## Appendix A – Stack Manufacturing Process and Cost Assumptions

### A.1 Bipolar Plate Manufacturing Process Documentation

#### *Model Approach*

- Setup operation
  - Machine setup labor cost based on input labor time; default = 4 hours
  - Tooling cost based on input insert and platen cost and life
- Pre-form operation
  - Measure and pre-form labor cost based on input labor time; default = 12 seconds
  - Part material cost based on input part volume and raw material cost
- Compression mold
  - Part handling time labor cost based on part size per BDI formula; 4 second minimum
  - Press cost based on part size, cycle time, platen energy, and standard machine rate
- Post bake
  - Part handling time labor cost based on part size per BDI formula and throughput; 4 second minimum
  - Process cost based on oven energy cost plus standard machine rate

#### *Process Flow*

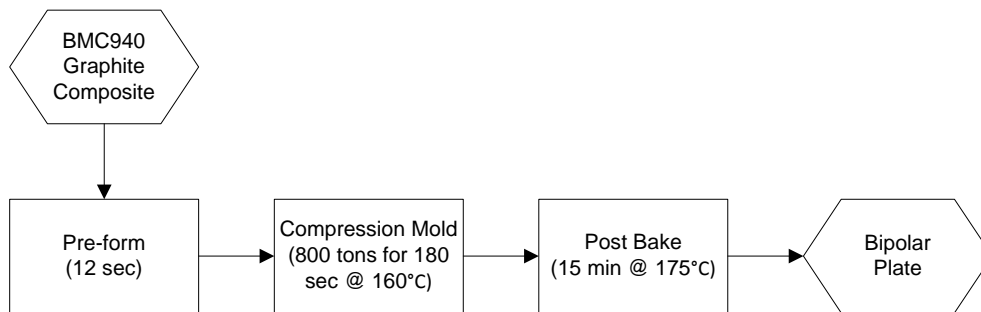

**Figure A-1. Bipolar Plate Manufacturing Process**

#### *Background*

A supplier of composite bipolar plates for PEM fuel cell stacks provided the following information regarding their process:

- Process requires a special press
  - High speed – 30 inches per second (ips)
  - High tonnage – 800 ton capacity to produce 1 part per cycle
  - Cure time in the press is 120-230 seconds
  - Allow 5% material overage

- Tooling costs
  - Inserts: \$45K-\$50K produces about 100,000 parts
  - Base: \$50K (reusable)
- Molding material supplied by Bulk Molding Compounds (BMC)
  - Has a consistency like sand
  - From BMC940 specification sheet
    - Mold temp: 300-320°F (149-160°C)
    - Recommended tonnage: >40MPa on projected part area
    - Press close speed: <2 seconds after material begins flowing
    - Post-mold bake at 350°F for 15 minutes

### ***Preliminary Analysis***

Unlike injection molding, compression molding requires that a pre-measured, usually pre-formed, and generally preheated amount of material be loaded into the mold insert prior to pressing. Given the stated consistency of the material, we will assume a manual weighing process followed by a manual packing process to get the material into the rough rectangular shape of the plate. No material pre-heating was mentioned by the manufacturer or the material spec sheet.

The bipolar plates for this analysis will be working in two systems:

$$10 \text{ kW Stack: } 175 \text{ mm width} \times 234 \text{ mm length} = 409.5 \text{ cm}^2$$

$$25 \text{ kW Stack: } 224 \text{ mm width} \times 304 \text{ mm length} = 681 \text{ cm}^2$$

Batch sizes will be calculated based on a quarterly production schedule producing 1,000 stacks per year.

The 10 kW stack requires 172 bipolar plates, requiring quarterly production of:

$$10 \text{ kW: } 172 \text{ plates/stack} \times 250 \text{ stacks} = 43,000 \text{ plates}$$

The 25 kW stack requires 214 bipolar plates, requiring quarterly production of:

$$25 \text{ kW: } 214 \text{ plates/stack} \times 250 \text{ stacks} = 53,500 \text{ plates}$$

### ***Setup***

We will assume one full setup per batch run of parts. This would include such things as platen and die installation, die alignment, work station setup and maintenance and operational checks. An analogous setup operation in the Boothroyd Dewhurst DFMA<sup>®</sup> software is for a powder metallurgy compaction press, for which the default value is 4 hours. The labor cost for setup will be the same for both the 10 kW and 25 kW plate sizes, and is modified by the overall plant efficiency and is allocated across the batch size as:

$$10 \text{ kW: Setup cost per part} = 4 \text{ hours} \times \$45/\text{hr} / 85\% / 43,000 \text{ parts} = \$0.005/\text{part}$$

The setup cost is negligible on a per part basis for both the 10 kW and 25 kW plates due to the large batch size required to make the quarterly production rate of 250 stacks. At the lowest volume of 100 stacks per year, it is likely that production would be done in one batch, making the setup cost:

$$10 \text{ kW: Setup cost per part} = 4 \text{ hours} \times \$45/\text{hr} / 85\% / 17,200 \text{ parts} = \$0.012/\text{part}$$



### ***Material Cost***

Anode and cathode side channels are generally 1 mm deep, indicating plate depth of around 3 mm. The material cost was quoted as \$11.01/kg by BMC in 2010. Given a material density of 1.9 g/cm<sup>3</sup> (BMC940 spec sheet) and 5% overage allowance, the material cost per part is approximately:

$$10 \text{ kW: Material cost} = \$11.01/\text{kg} \times 1.9 \text{ g/cm}^3 \times 0.001 \text{ kg/g} \times (409.5 \times .3) \text{ cm}^3 \times 1.05 = \$2.70/\text{part}$$

$$25 \text{ kW: Material cost} = \$11.01/\text{kg} \times 1.9 \text{ g/cm}^3 \times 0.001 \text{ kg/g} \times (681 \times .3) \text{ cm}^3 \times 1.05 = \$4.49/\text{part}$$

### ***Compression Molding Press Cost***

The material specification recommends molding pressure in excess of 40 MPa (0.4 tons/cm<sup>2</sup>) on the projected part area. For the two sizes of bipolar plates:

$$10 \text{ kW: Tonnage} = 0.4 \text{ tons/cm}^2 \times 409.5 \text{ cm}^2 = 164 \text{ tons}$$

$$25 \text{ kW: Tonnage} = 0.4 \text{ tons/cm}^2 \times 681 \text{ cm}^2 = 272 \text{ tons}$$

Discussions with a bipolar plate manufacturer indicate the use of a special fast-acting 800 ton press. For a press of that capacity, and allowing for some capacity margin, it is feasible to mold four 10 kW plates per cycle (656 tons), and two 25 kW plates per cycle (544 tons).

The primary energy input to run the press is hydraulic motor power. Surveying press manufacturers Wabash, Beckwood, and Karunanand, the hydraulic motor size for 800 ton presses appears as either 30 or 50 HP, but lists pressing speeds of only 20 ipm (0.3 ips). Cylinder bore sizes are listed as 26"-30" diameter. To move a 30" diameter cylinder at 30 ips requires a pump delivery of:

$$\text{Flow rate} = (30'')^2 \times (\pi / 4) \times 30''/\text{sec} \times 60 \text{ sec/min} \times 0.004 \text{ gal/in}^3 = 5089 \text{ gpm}$$

This is beyond the practical limit of most high performance hydraulic gear pumps, which tend to have maximum flow rates of 90 gpm at 100 HP input power and 2500 psi working output pressure (reference Commercial Intertech P365 series hydraulic pumps).

To supply 800 tons of force using a 30" cylinder requires a delivery pressure of:

$$\text{Pressure} = 800 \text{ tons} \times 2240 \text{ lbs/long ton} / ((30'')^2 \times (\pi / 4)) = 2535 \text{ psi}$$

For this analysis, we will assume two 100 HP (75 kW) pumps feeding a set of staged cylinders; e.g. two smaller diameter cylinders to provide the necessary pressing speed, and one larger cylinder to develop the required pressure. To provide some limited scalability, we assume that 150 kW of input power is required to mold a four 409.5 cm<sup>2</sup> bipolar plates, giving a factor of approximately 0.091 kW/cm<sup>2</sup> of plate area. For larger plates, we will assume 2 parts per cycle.

Total press cycle time is the sum of part handling time, press actuation time, and press dwell time. An empirical formula developed by Boothroyd Dewhurst calculates a quantity called part girth, then calculates a theoretical total handling time (both load and unload) with a minimum value of 4 seconds, as follows:

$$\text{Part girth} = \text{Part length} + \text{Part width} + \text{part depth}$$

$$\text{Handling time} = \text{Max}((0.60714 \times (\text{Part girth} / 25.4) - 4.57143), 4)$$

$$10 \text{ kW: Handling time} = \text{Max}((0.60714 \times ((175 + 234 + 3) / 25.4) - 4.57143), 4) = 5.3 \text{ sec}$$

$$25 \text{ kW: Handling time} = \text{Max}((0.60714 \times ((224 + 304 + 3) / 25.4) - 4.57143), 4) = 8.1 \text{ sec}$$

For an actuation time of 10 sec, dwell time of 230 sec, and handling times shown above, the total cycle time is:

$$10 \text{ kW: Total cycle time} = ((4 \times 5.3) + 230 + 10) = 261.2 \text{ sec/cycle} = 0.0726 \text{ hours/cycle}$$

$$25 \text{ kW: Total cycle time} = ((2 \times 8.1) + 230 + 10) = 256.2 \text{ sec/cycle} = 0.0712 \text{ hours/cycle}$$

Throughput is calculated as:

$$10 \text{ kW: Parts per hour} = 4 \text{ parts/cycle} / 0.0726 \text{ hours/cycle} = 55.1 \text{ parts/hour}$$

$$25 \text{ kW: Parts per hour} = 2 \text{ parts/cycle} / 0.0712 \text{ hours/cycle} = 28.1 \text{ parts/hour}$$

Total press energy can be calculated as:

$$10 \text{ kW: Press energy} = 0.091 \text{ kW/cm}^2 \times 4 \text{ parts/cycle} \times 409.5 \text{ cm}^2/\text{part} = 149.1 \text{ kW}$$

$$10 \text{ kW: Press energy cost} = 149.1 \text{ kW} \times \$0.07/\text{kW-hr} / 55.1 \text{ parts/hour} = \$0.189/\text{part}$$

$$25 \text{ kW: Press energy} = 0.091 \text{ kW/cm}^2 \times 2 \text{ parts/cycle} \times 681 \text{ cm}^2/\text{part} = 123.9 \text{ kW}$$

$$25 \text{ kW: Press energy cost} = 123.9 \text{ kW} \times \$0.07/\text{kW-hr} / 28.1 \text{ parts/hour} = \$0.309/\text{part}$$

### ***Tooling Cost***

Tooling consists of the mold inserts and the heated platens. Contact with Custom Engineering Co. (platens.com) indicates that platens in the size range required will generally consist of 2"-2.5" thick aluminum plates loaded with electric cartridge heaters spaced 3" (7.6 cm) apart. Costs will be in the range of \$10,000 for a 7500 cm<sup>2</sup> platen, and \$3500 for the controller. No life was provided for the platens. An engineering estimate based on heater life would be around 500,000 cycles.

10 kW Platens: Assuming 4 plates per cycle with 50 mm margin between and around each plate, the total platen area is:

$$10 \text{ kW: Platen width} = ((2 \times 175 \text{ mm}) + 150 \text{ mm}) = 500 \text{ mm}$$

$$10 \text{ kW: Platen length} = ((2 \times 234 \text{ mm}) + 150 \text{ mm}) = 618 \text{ mm}$$

$$10 \text{ kW: Platen area} = 500 \text{ mm} \times 618 \text{ mm} = 3090 \text{ cm}^2$$

Cost for a single platen can be estimated at about \$4000.

The manufacturer provided estimates for single part inserts as \$45K-\$50K with an expected life of about 100,000 cycles. Using the Boothroyd Dewhurst DFMA<sup>®</sup> software, the tooling cost for a 4 part insert was estimated at \$204,000, consistent with a tooling cost of around \$50K per part molded. Total tooling costs per part is calculated as:

$$10 \text{ kW: Tooling cost} = (\$200,000 / 100,000 \text{ cycles}) + (2 \times \$4,000 / 500,000 \text{ cycles}) / 4 \text{ parts/cycle} = \$0.504/\text{part}$$

25 kW Platens: Assuming 2 plates per cycle arranged width-wise with 50 mm margin between and around each plate, the total platen area is:

$$25 \text{ kW: Platen width} = ((2 \times 224 \text{ mm}) + 150 \text{ mm}) = 598 \text{ mm}$$

$$25 \text{ kW: Platen length} = 304 \text{ mm} + 100 \text{ mm} = 404 \text{ mm}$$

$$25 \text{ kW: Platen area} = 598 \text{ mm} \times 404 \text{ mm} = 2416 \text{ cm}^2$$

Cost for a single platen can be estimated at about \$3200.

Using the Boothroyd Dewhurst DFMA<sup>®</sup> software, the tooling cost for a 4 mold insert was estimated at \$165,000. Total tooling costs per part is calculated as:

$$25 \text{ kW: Tooling cost} = (\$100,000 / 100,000 \text{ cycles}) + (2 \times \$3,200 / 500,000 \text{ cycles}) / 2 \text{ parts/cycle} \\ = \$0.506/\text{part}$$

### ***Heated Platen Energy Cost***

Omega (<http://www.omega.com/prodinfo/cartridgeheaters.html>) estimates 0.5" cartridge heaters to have a watt density of 50W per inch of heater length (about 20W per cm length). Calculating the total input heater power for the platen based on 3 inch (7.6 cm) heater spacing:

$$\text{Number of heaters} = \text{Ceiling}(\text{Platen length (cm)} / 7.6)$$

$$\text{Platen power input} = \text{Number of heaters} \times (\text{Platen width (cm)} \times 20 \text{ (W/cm)})$$

$$10 \text{ kW: Number of heaters} = \text{Ceiling} (50 \text{ cm} / 7.6 \text{ cm}) = 7$$

$$10 \text{ kW: Platen power input} = 7 \text{ heaters} \times (61.8 \text{ cm} \times 20 \text{ W/cm}) = 8.65 \text{ kW}$$

$$25 \text{ kW: Number of heaters} = \text{Ceiling} (59.8 \text{ cm} / 7.6 \text{ cm}) = 8$$

$$25 \text{ kW: Platen power input} = 8 \text{ heaters} \times (40.4 \text{ cm} \times 20 \text{ W/cm}) = 6.46 \text{ kW}$$

The mold insert will be attached to heated platens that are capable of maintaining the proper mold temperature of up to 160°C. The energy required to heat the platen at the start of a batch run can be calculated using the heat equation:  $\Delta Q = \rho v c p \Delta T$ . Assuming a 2" thick 6061 aluminum plate heated from 25°C to 160°C:

$$10 \text{ kW: Volume} = 3090 \text{ cm}^2 \times 5.1 \text{ cm} = 15,759 \text{ cm}^3$$

$$10 \text{ kW Energy} = 2.7 \text{ g/cm}^3 \times 15,759 \text{ cm}^3 \times 0.896 \text{ J/g-}^\circ\text{C} \times 135^\circ\text{C} \times 2.8 \times 10^{-7} \text{ kW-hr/J} = 1.44 \text{ kW-hr}$$

Assuming an energy cost of \$0.07/kW-hr and 90% heating efficiency, the cost of heating the platens is about \$0.11; negligible on a per part basis for the 10 kW plates. Because the platens for molding the 25 kW plates are smaller, the cost of heating will be less, and therefore also negligible on a per part basis.

The energy required to maintain the platen temperature throughout the batch run is the combination of conductive and convective heat losses during the pressing operation. The energy required to heat the material from 25°C to 160°C is:

$$10 \text{ kW: Energy} = 1.9 \text{ g/cm}^3 \times (4 \times 122.85) \text{ cm}^3 \times 1.05 \times 0.846 \text{ J/g-}^\circ\text{C} \times 135^\circ\text{C} \times (2.8 \times 10^{-7} \text{ kW-hr/J}) = 0.031 \text{ kW-hr}$$

Convective heat losses to the air ( $h = 20 \text{ W/m}^2\text{-}^\circ\text{C}$ ) due to ambient air flow across the plates occurs across the face and edges of the platen:

$$10 \text{ kW: Area} = 3090 \text{ cm}^2 + (2 \times (59.8 \times 5.1)) + (2 \times (40.4 \times 5.1)) = 4112 \text{ cm}^2 = 0.411 \text{ m}^2$$

$$10 \text{ kW:} = 20 \text{ W/m}^2\text{-}^\circ\text{C} \times 0.411 \text{ m}^2 \times 135^\circ\text{C} \times 2 \text{ platens} = 2.22 \text{ kW}$$

Assuming an energy cost of \$0.07/kW-hr, the cost of keeping the platens hot over a cycle is:

$$10 \text{ kW: Energy cost} = \$0.07/\text{kW-hr} \times (0.031 \text{ kW-hr} + (2.22 \text{ kW} \times 0.0726 \text{ hr/cycle})) / 4 \text{ parts/cycle} \\ = \$0.003/\text{part}$$

Once again, because the platens for molding the 25 kW plates are smaller, the cost of heating will be less, and therefore also negligible on a per part basis. While energy cost on a per part basis appear negligible, a study conducted by the food service industry, indicates that 3 foot electric griddles with rated energy inputs of 8-16 kW demonstrate a 25% duty cycle in actual use. Given that the surface areas, power densities, and manual work flow are comparable, we will assume a similar usage profile, giving platen energy cost of:

$$10 \text{ kW: Energy cost} = \$0.07/\text{kW-hr} \times (0.25 \times 8.65 \text{ kW}) / 55.1 \text{ parts/hour} = \$0.003/\text{part}$$

Given the agreement between the two calculations, we will assume the 25% duty cycle for cost estimating purposes.

### ***Post Bake Cost***

The BMC940 material spec sheet calls for a post bake at 350°F (177°C) for 15 minutes after the part reaches temperature. For a batch type oven, the strategy is to rack parts in quantities that permit racks to be interchanged in 15 minute intervals. Given a minimum per part molding time of approximately 120 seconds, minimum cycle time is:

$$10 \text{ kW: Total cycle time} = ((4 \times 5.3) + 120 + 10) = 151.2 \text{ sec/cycle} = 0.042 \text{ hours/cycle}$$

$$25 \text{ kW: Total cycle time} = ((2 \times 8.1) + 120 + 10) = 146.2 \text{ sec/cycle} = 0.041 \text{ hours/cycle}$$

Therefore, we can expect a maximum throughput of:

$$10 \text{ kW: Parts per hour} = 4 \text{ parts/cycle} / 0.042 \text{ hours/cycle} = 95.2 \text{ parts/hour} = 24 \text{ parts per bake cycle}$$

$$25 \text{ kW: Parts per hour} = 2 \text{ parts/cycle} / 0.041 \text{ hours/cycle} = 48.8 \text{ parts/hour} = 13 \text{ part per bake cycle}$$

For this level of production, we will assume that an industrial bench oven will provide sufficient capacity. One example is the Grieve NBS-400 with 4 kW heating capacity capable of reaching 400°F (204°C), 28" x 24" x 18" (0.2 m<sup>3</sup>) working volume with 7 shelf capacity, and 2"(5 cm) rockwool insulation (k = 0.045 W/m°C) on 304 stainless steel construction.

The energy required to heat the oven at the start of a batch run can be calculated using the heat equation:  $\Delta Q = \rho v c_p \Delta T$ . Assuming walls of 1/16" thick, the energy required to heat the steel from 25°C to 177°C:

$$\text{Volume} = (2 \times (71 \times 61) + 2 \times (71 \times 46) + 2 \times (61 \times 46)) \times 0.16 = 3329 \text{ cm}^3$$

$$\text{Energy} = 8.3 \text{ g/cm}^3 \times 3329 \text{ cm}^3 \times 0.5 \text{ J/g} \cdot \text{°C} \times 152 \text{°C} \times 2.8 \times 10^{-7} \text{ kW-hr/j} = 0.59 \text{ kW-hr}$$

Assuming an energy cost of \$0.07/kW-hr and 90% heating efficiency, the cost of heating the oven is about \$0.05; negligible on a per part basis.

The energy required to maintain the oven temperature throughout the batch run is the combination of conductive heat losses through the walls, and the convective heat losses during rack transfer. Estimating the conductive losses through the rockwool insulation (0.05 m thick):

$$\text{Area} = 2 \times (0.71 \times 0.61) + 2 \times (0.71 \times 0.46) + 2 \times (0.61 \times 0.46) = 2.1 \text{ m}^2$$

$$\text{Energy} = 0.045 \text{ W/m}^2\text{°C} \times 2.1 \text{ m}^2 \times 152\text{°C} / 0.05 \text{ m} = 0.29 \text{ kW}$$

The Grieve NBS-400 has an interior surface area of:

$$\text{Area} = (2 \times (71 \times 61)) + 2 \times (71 \times 46) + 2 \times (61 \times 46) = 20806 \text{ cm}^2 = 2.08 \text{ m}^2$$

Assuming convective losses to the air ( $h = 20 \text{ W/m}^2\text{-°C}$ ) from all interior surfaces during rack exchange, and assuming 4 seconds to remove and 4 seconds to replace 4 times per hour (0.009 hours), is:

$$\text{Energy} = 20 \text{ W/m}^2\text{-°C} \times 2.08 \text{ m}^2 \times 152\text{°C} \times 0.009 \text{ hrs} = 0.06 \text{ kW}$$

The energy cost for 1 hour of operation assuming an energy cost of \$0.07/kW-hr is approximately \$0.025. While energy cost on a per part basis appear negligible, a study conducted by the food service industry, indicates that “deck ovens” demonstrate a 20% duty cycle in actual use. Given that the usage scenarios are comparable, we will assume a similar usage profile.

For the post bake step, we assume that parts will be racked to facilitate swapping parts at intervals equal to the bake time in order to minimize oven heat loss. Consequently, each part will incur a labor cost for the rack/unrack process, and a fraction of the labor cost for the oven load and unload process. A rack of four 10 kW parts will fit onto one shelf, as will a rack of two 25 kW parts. Assuming a rack depth of 10 mm and 50 mm part margin, an estimate of the rack handling time is:

$$\text{Rack girth} = (\text{Parts per rack} \times (\text{Part width (mm)} + 50)) + (\text{Part length (mm)} + 50) + 10$$

$$10 \text{ kW: Rack girth} = (4 \times (175 + 50)) + (234 + 50) + 10 = 1194$$

$$10 \text{ kW: Rack handling time} = \text{Max}((0.60714 \times ((1194) / 25.4) - 4.57143), 4) = 23.7 \text{ sec}$$

$$25 \text{ kW: Rack girth} = (2 \times (224 + 50)) + (304 + 50) + 10 = 912$$

$$25 \text{ kW: Rack handling time} = \text{Max}((0.60714 \times ((912) / 25.4) - 4.57143), 4) = 17.2 \text{ sec}$$

The cost of part handling is computed as:

$$10 \text{ kW: Total handling time per part} = 5.3 + (23.7 / 4) = 11.2$$

$$10 \text{ kW: Handling cost} = (11.2 \text{ sec} / 3600 \text{ sec/hr}) * \$45/\text{hr} / 85\% = \$0.165/\text{part}$$

$$25 \text{ kW: Total handling time per part} = 8.1 + (17.2 / 2) = 16.7$$

$$25 \text{ kW: Handling cost} = (16.7 \text{ sec} / 3600 \text{ sec/hr}) * \$45/\text{hr} / 85\% = \$0.246/\text{part}$$

## A.2 End Plate Manufacturing Process Documentation

### *Model Approach*

- Use standard Boothroyd-Dewhurst (BDI) cell machining cost analysis
  - Near net shape workpiece
  - Face mill top and bottom
  - Finish end mill plate perimeter
  - Rough and finish pocket mill lightening cavities
  - Drill tie rod holes
  - Drill, ream, and tap gas connector mounting holes

## Process Flow

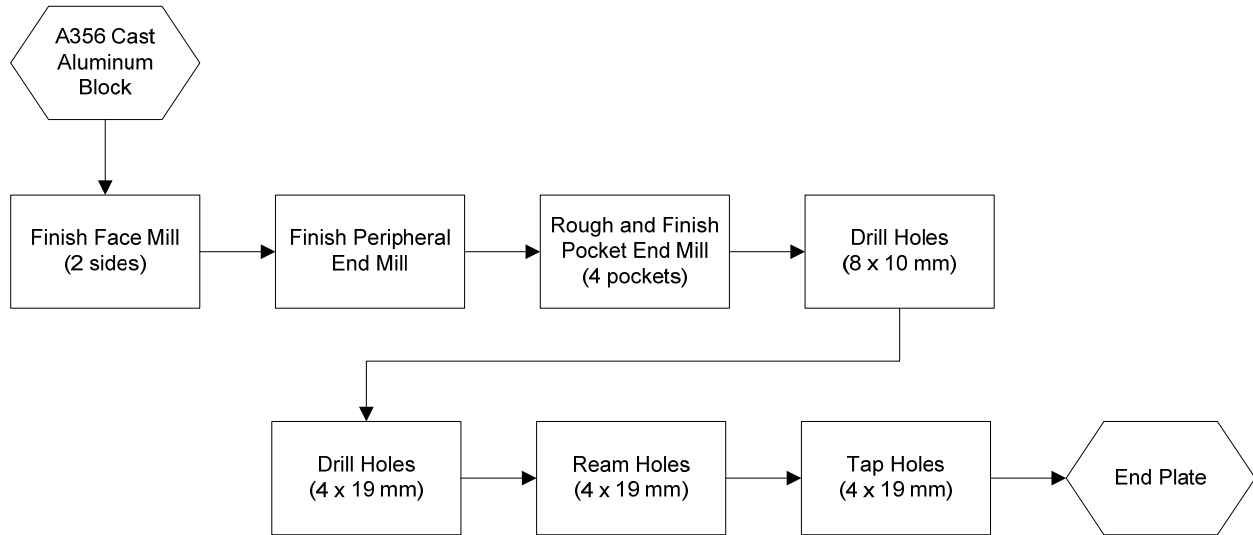

Figure A-2. End Plate Manufacturing Process

## Background

The BDI software provides pre-programmed cost models for the cell machining operations (cutoff, mill, ream and tap operations) used to manufacture the fuel cell stack end plates. The end plates need to be rigid in order to apply even pressure across the face of the stack, and light weight for vehicle applications.

The initial process selection was a die cast part with finish machine. The software flagged the process as unsuitable for parts as having section thicknesses greater than 12 mm. Therefore, the process selected for the initial cost estimate was cell machining of A356 cast aluminum block.

## Preliminary Analysis

The end plates will align with the fuel cell stack across the length of the plate, and overhang the stack width by 20 mm on each side to accommodate the tie rods that will press and hold the stack together. The end plate will also have four reamed and tapped holes for mounting fuel and exhaust gas connectors. This analysis will use the end plate dimensions shown below as an example.

The plates for this analysis will be working in two systems for which the size of the cell is:

10 kW Stack: 175 mm width × 234 mm length

10 kW End Plate: 215 mm width × 234 mm length

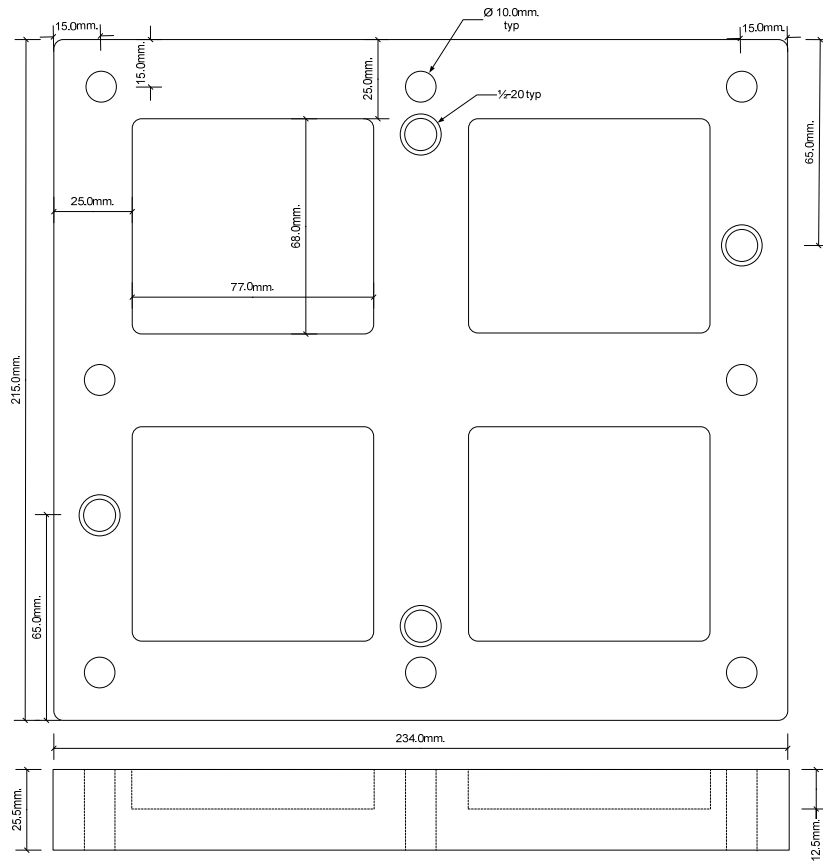

25 kW Stack: 224 mm width × 304 mm length  
 25 kW End Plate: 264 mm width × 304 mm length

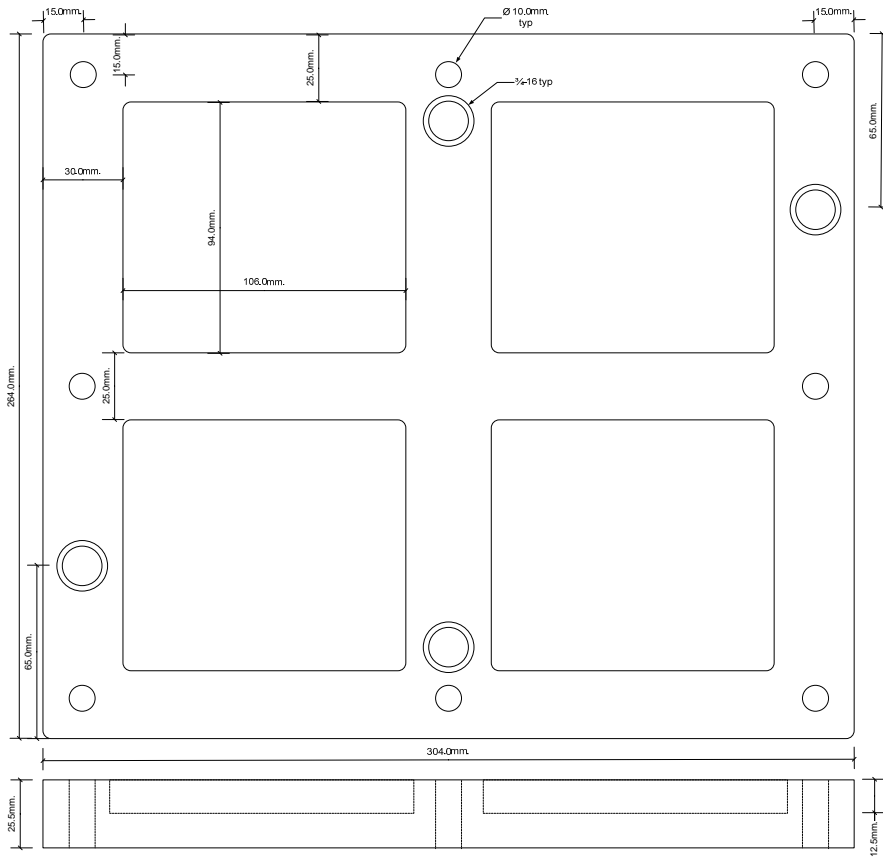



*DFM Software Analysis*

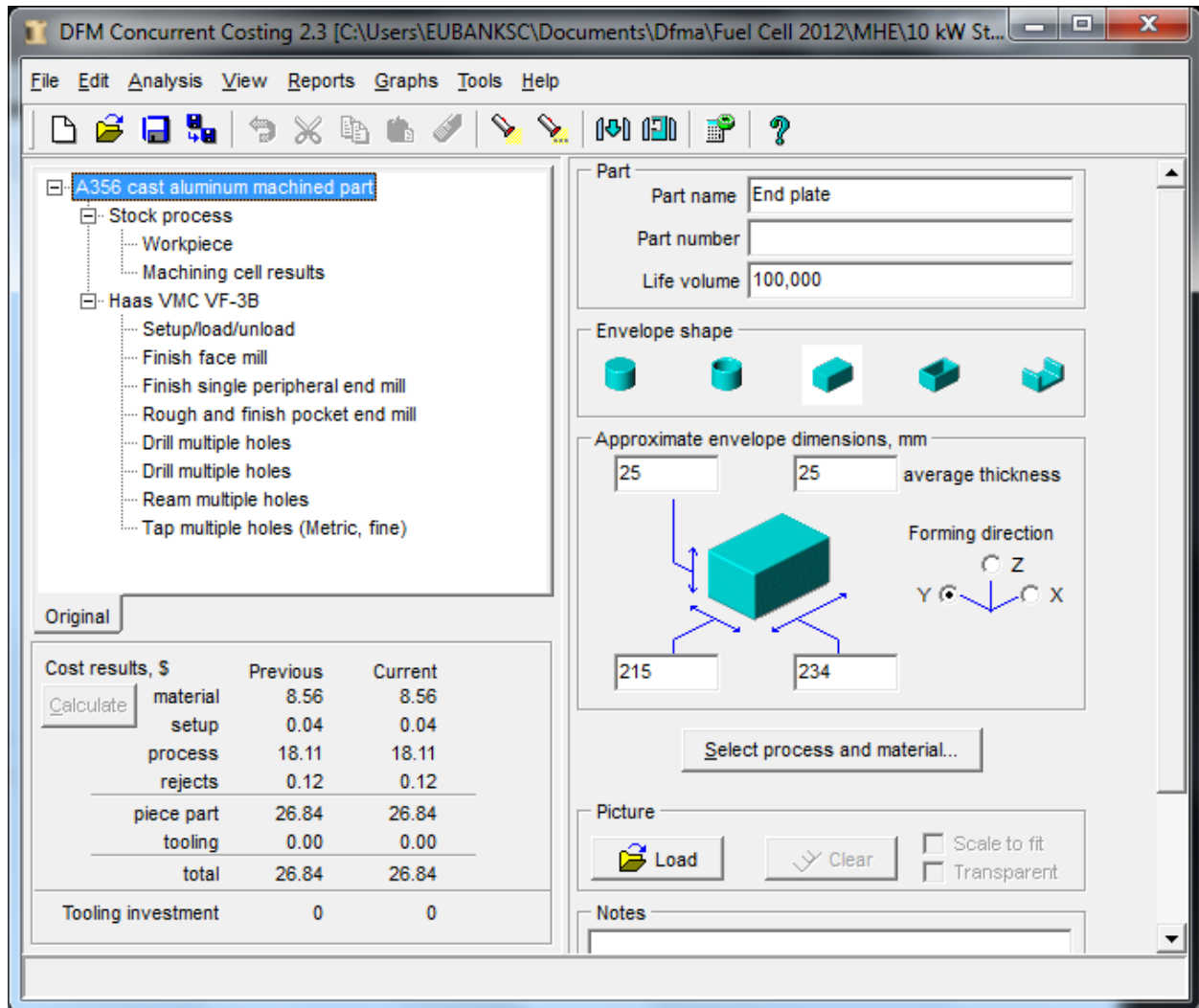

**Figure A-3. DFM Analysis for 10 KW End Plate**

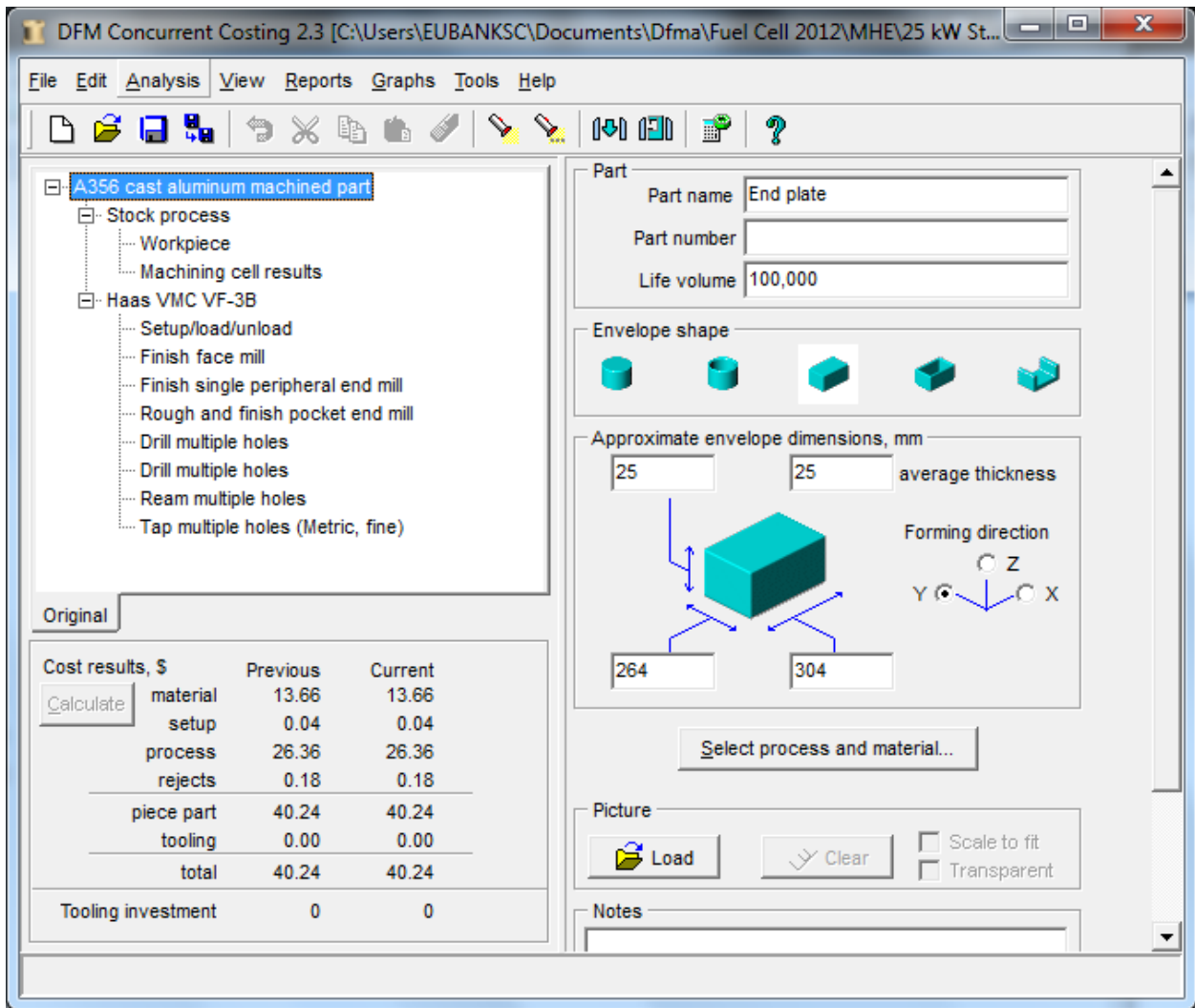

Figure A-4. DFM Analysis for 25 KW End Plate

## A.3 Gasket Manufacturing Process Documentation

### Model Approach

- Die cutting operation
  - Machine setup labor cost based on number of setups required to process material and input labor time; default = 1 hour
  - Tooling cost based on die cutting length and die life
  - Press cost based on cutting force required and standard machine rate

### Process Flow

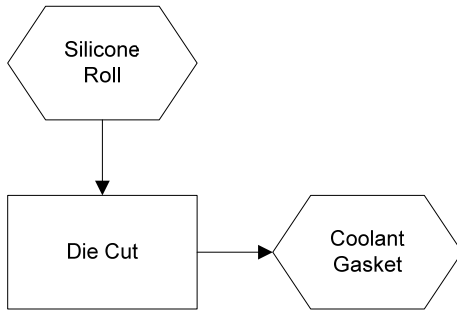

Figure A-5. Gasket Manufacturing Process

### Background

The primary method for producing elastomeric gaskets with standard features and tolerances is steel rule die cutting. The outline of the gasket is laid out and cut into a board. Strip steel is embedded into the board at a uniform height and mounted on a small stroke, fast acting press. The bulk gasket material, either as rolls or in sheet form, is fed into the press where the steel rule die shears the material. The gasket cutout is then pushed out of the bulk material.

### Preliminary Analysis

The cells for this analysis will be working in two systems for which the size of the cell is:

$$10 \text{ kW Stack: } 175 \text{ mm width} \times 234 \text{ mm length} = 409.5 \text{ cm}^2$$

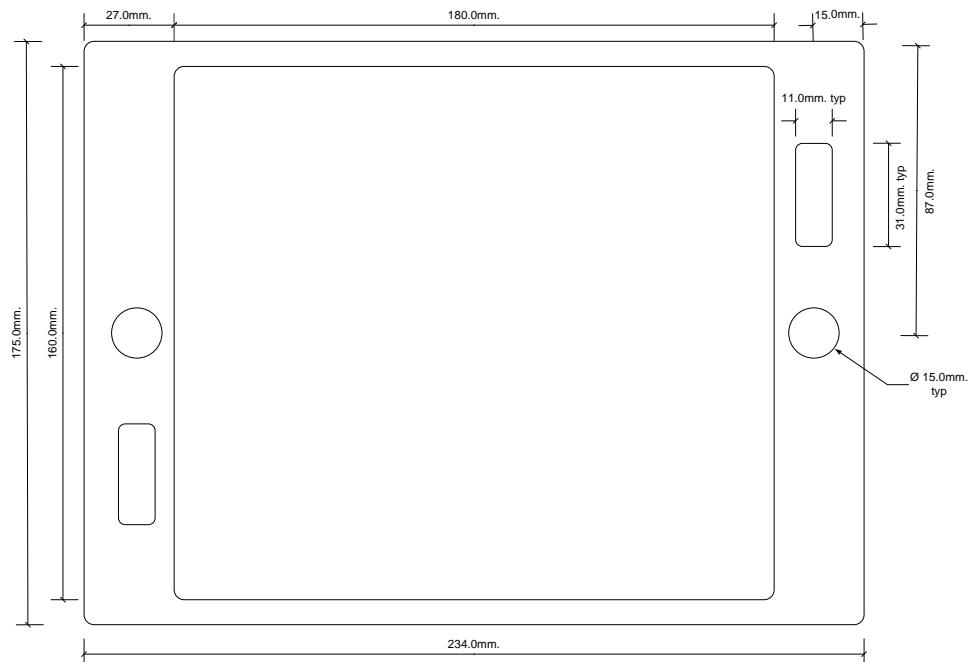

$$25 \text{ kW Stack: } 224 \text{ mm width} \times 304 \text{ mm length} = 681 \text{ cm}^2$$

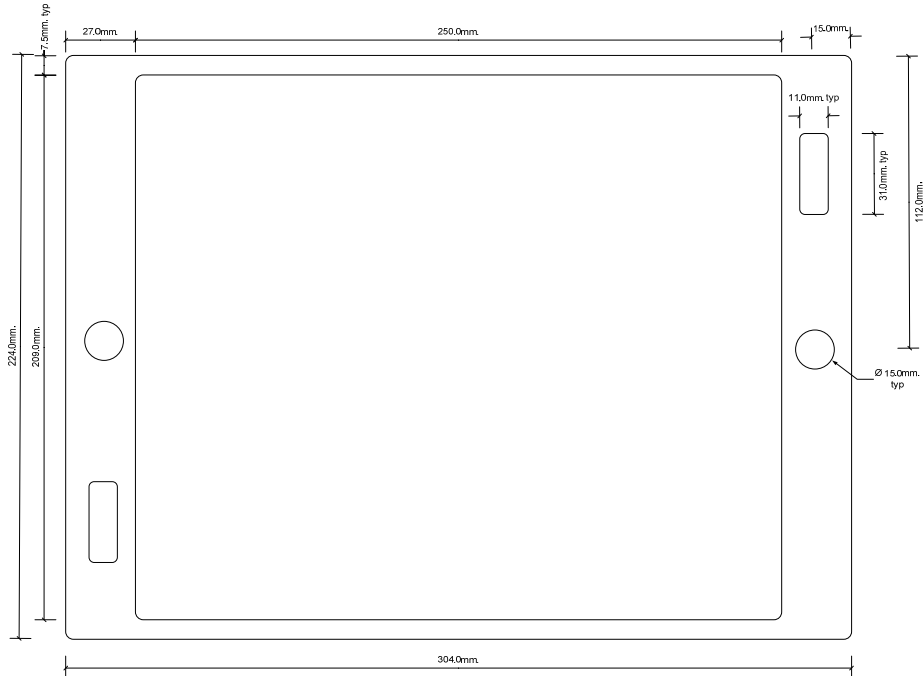

**Setup**

Silicone gasket material generally comes in standard lengths up to 100 feet (30.5 meters) and widths up to 48” (1.22 meters) although 36” (0.9 meters) seems to be more widely available. Depending on the roll length and width, multiple machine setups may be required to process the material for an entire production run. The length of material being processed is a function of the batch size and the number of parts that can be produced across the material width. Assuming no cutting margin for rectangular gaskets, the optimal part orientation can be determined based on the fraction of material width left over as waste as:

Number of lengthwise parts = floor(Roll width / Part length)

Lengthwise waste fraction = (Roll width / Part length) - Number of lengthwise parts

10 kW: Number of lengthwise parts = floor(0.9 m / 0.234 m) = 3

10 kW: Lengthwise waste fraction = (0.9 m / 0.234 m) - 3 = 0.846

25 kW: Number of lengthwise parts = floor(0.9 m / 0.304 m) = 2

25 kW: Lengthwise waste fraction = (0.9 m / 0.304 m) - 2 = 0.961

The same calculations for the widthwise orientation is

10 kW: Number of widthwise parts = floor(0.9 m / 0.175 m) = 5

10 kW: Widthwise waste fraction = (0.9 m / 0.175 m) - 5 = 0.14

25 kW: Number of widthwise parts = floor(0.9 m / 0.224 m) = 4

25 kW: Widthwise waste fraction = (0.9 m / 0.224 m) - 4 = 0.018

The number of parts per press cycle (equal to number of die cavities) and length of material required is then obtained by comparing the waste fraction:

If (Widthwise waste fraction < Lengthwise waste fraction)

Number of cavities = Number of widthwise parts

Material length = Part length (m) × Batch size (parts) / Number of cavities

Else

Number of cavities = Number of lengthwise parts

Material length = Part width (m) × Batch size (parts) / Number of cavities

In each case above, width-wise orientation is preferred, making the material length:

10 kW: Material length = 0.234 m × 21,500 parts / 5 cavities = 1006.2 meters

25 kW: Material length = 0.304 m × 26,750 parts / 4 cavities = 2033 meters

Therefore, the number of setups required for 0.9 x 30.5 meter rolls is:

10 kW: Number of setups = Ceiling(1006.2 m / 30.5 m) = 33 setups

25 kW: Number of setups = Ceiling(2033 m / 30.5 m) = 67 setups

Assuming a 1-hour setup time at a labor cost of \$45/hr and overall plant efficiency of 85%, the setup cost per part is:

10 kW: Setup cost = 33 × 1 hr × \$45/hr / 0.85 / 21,500 = \$0.081/part

25 kW: Setup cost = 67 × 1 hr × \$45/hr / 0.85 / 26,750 = \$0.133/part

### ***Tooling***

The primary factor contributing to steel rule die cost is the total cutting length of the die. For the configurations shown above, the cutting length (mm) is:

10 kW: Cutting length = 2 × (234 + 175) + 2 × (180 + 160) + 4 × (31 + 11) + 2 × (π × 15) = 1760 mm

25 kW: Cutting length = 2 × (304 + 224) + 2 × (250 + 209) + 4 × (31 + 11) + 2 × (π × 15) = 2236 mm

A rough quote of approximately \$230 was obtained from steel-rule-dies.com for a two cavity die with the above example configuration.

Tooling rate = \$230 / (2 × 2706) mm = \$0.04/mm

Information obtained from Mag-Knight ([www.mag-knight.com/diecutting/Steel\\_Rule\\_Dies.htm](http://www.mag-knight.com/diecutting/Steel_Rule_Dies.htm)) indicates that dies used to cut softer materials have an expected life of about 30,000 hits. Total tooling cost per part for a 4 cavity die can be calculated as:

Tooling cost = Number of cavities × Cutting length (mm) × Tooling rate / Tooling life

10 kW: Tooling cost = 5 dies × 1760 mm/die × \$0.04/mm / 30000 parts = \$0.012/part

25 kW: Tooling cost = 4 dies × 2236 mm/die × \$0.04/mm / 30000 parts = \$0.012/part

## ***Material***

The anode and cathode gaskets are expected to be no more than 0.8 mm thick. On-line quotes for silicone roll material range from \$9 - \$11 per foot on 36" x 100 foot rolls, or about \$3.33/ft<sup>2</sup> (\$35.88/m<sup>2</sup>). The material cost per part is calculated as the bulk material cost multiplied by the total amount of material required to process the batch divided by the batch size:

Material cost = Bulk material cost (\$/m<sup>2</sup>) × Material length (m) × Roll width (m) / Batch size (parts)

$$10 \text{ kW: Material cost} = \$35.88/\text{m}^2 \times 1006.2 \text{ m} \times 0.9 \text{ m} / 21,500 \text{ parts} = \$1.51/\text{part}$$

$$25 \text{ kW: Material cost} = \$35.88/\text{m}^2 \times 2033 \text{ m} \times 0.9 \text{ m} / 26,750 \text{ parts} = \$2.45/\text{part}$$

## ***Die Cutting***

The primary energy input to run the press is hydraulic pump motor power. The total force required to cut the material is the total shear area (cutting length × material thickness) multiplied by the material shear strength. Using 11 N/mm<sup>2</sup> as the shear strength of silicone rubber, the total required press force is calculated as:

Press force = Number of cavities × Cutting length (mm) × Material thickness (mm) × Shear strength (N/mm<sup>2</sup>)

$$10 \text{ kW: Press force} = 5 \text{ dies} \times 1760 \text{ mm/die} \times 0.8 \text{ mm} \times 11 \text{ N/mm}^2 = 77.44 \text{ kN} = 7.77 \text{ tons}$$

$$25 \text{ kW: Press force} = 4 \text{ dies} \times 2236 \text{ mm/die} \times 0.8 \text{ mm} \times 11 \text{ N/mm}^2 = 78.71 \text{ kN} = 7.9 \text{ tons}$$

A survey of 15 to 100 ton (150 – 1000 kN) fast-acting die cutting presses found that the motor power required to operate the press fell in the range of 0.015 – 0.025 kW/kN. Assuming a 50% capacity margin and using the upper end of the motor power rating, the required press energy input is:

$$\text{Press energy} = 79 \text{ kN} \times 1.5 \times 0.025 \text{ kW/kN} = 2.97 \text{ kW}$$

The cost of energy usage to operate the press is calculated as:

$$\text{Press energy rate} = \$0.07/\text{kW-hr} \times 2.97 \text{ kW} = \$0.207/\text{hr}$$

Typical die cutting press speed ranges from 30 – 60 cycles/min (1800 – 3600 cycles/hour). Assuming the slower speed, the time to process a batch of parts is calculated as

Batch processing time = Batch size (parts) / (Part per cycle × Cycles per hour)

$$10 \text{ kW: Batch processing time} = 21,500 \text{ parts} / (5 \text{ parts/cycle} \times 1800 \text{ cycle/hour}) = 2.39 \text{ hours}$$

$$25 \text{ kW: Batch processing time} = 26,750 \text{ parts} / (4 \text{ parts/cycle} \times 1800 \text{ cycle/hour}) = 3.72 \text{ hours}$$

The total machine cost per part is calculated as the press energy cost (\$/hr) plus the standard machine cost (\$/hr) multiplied by the batch processing time and divided by the overall plant efficiency and batch size:

$$10 \text{ kW: Machine cost} = ((\$0.207/\text{hr} + \$25/\text{hr}) \times 2.39 \text{ hours}) / 0.85 / 21,500 \text{ parts} = \$0.003/\text{part}$$

$$25 \text{ kW: Machine cost} = ((\$0.207/\text{hr} + \$25/\text{hr}) \times 3.72 \text{ hours}) / 0.85 / 26,750 \text{ parts} = \$0.004/\text{part}$$

The total labor cost per part is calculated as the number of operators per machine multiplied by the labor rate (\$/hr) and batch processing time and divided by the overall plant efficiency and batch size:

10 kW: Labor cost = (1 operator × \$45/hr × 2.39 hours) / 0.85 / 21,500 parts = \$0.006/part

25 kW: Labor cost = (1 operator × \$45/hr × 3.72 hours) / 0.85 / 26,750 parts = \$0.007/part

## A.4 Membrane Electrode Assembly (MEA) Hot Processing Manufacturing Documentation

### Model Approach

- Hot press operation
  - Machine setup labor cost based on number of setups required to process material and input labor time; default = 1 hours
  - Tooling cost based on input platen cost and life
  - Press cost based on part size, cycle time, platen energy, and standard machine rate

### Process Flow

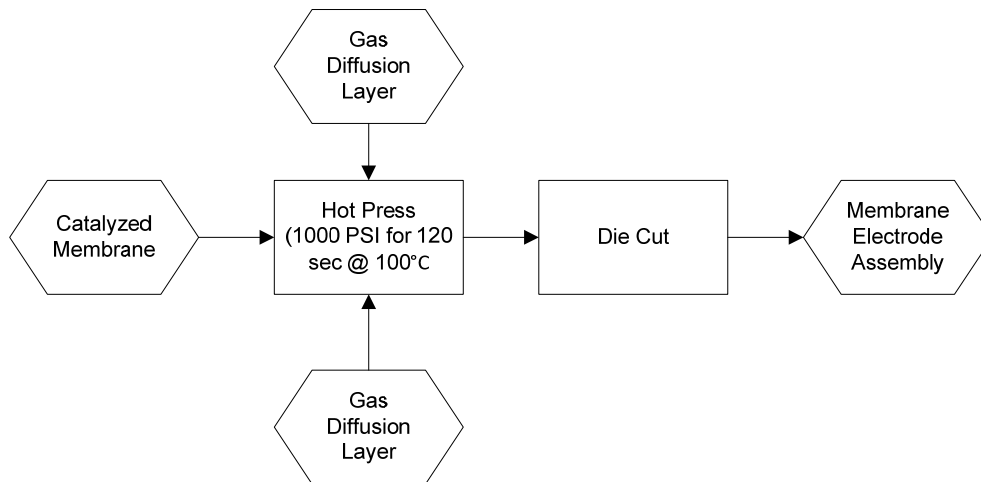

Figure A-6. MEA Hot Processing Manufacturing Process

### Background

In “Mass Production Cost Estimation for Direct H<sub>2</sub> PEM Fuel Cell Systems for Automotive Applications: 2010 Update,” Directed Technologies, Inc. (DTI) reported hot pressing conditions for MEA fabrication as 160°C for 90 seconds using heated platens of 0.5 m wide by 1.5 m long for processing 0.5 m wide roll materials. They estimated a reset period of 3 seconds to open the press, index the materials, and re-close the press.

In “Investigation of membrane electrode assembly (MEA) hot-pressing parameters for proton exchange membrane fuel cell,” (Energy, 32:12, December 2007, Pages 2401–2411), Therdthianwong, et.al. found that the most suitable hot pressing conditions for MEA fabrication to be 100°C and 1000 psi (70 kg/cm<sup>2</sup>) for 2 minutes, stating that these conditions “...provided the highest maximum power density from the MEA and the best contact at the interfaces between the gas diffusion layer, the active layer, and the electrolyte membrane.”

### ***Preliminary Analysis***

The cells for this analysis will be working in two systems for which the size of the cell is:

$$10 \text{ kW Stack: } 175 \text{ mm width} \times 234 \text{ mm length} = 409.5 \text{ cm}^2$$

$$25 \text{ kW Stack: } 224 \text{ mm width} \times 304 \text{ mm length} = 681 \text{ cm}^2$$

We will assume that the width of the materials to be pressed (two gas diffusions layers (GDL) and catalyzed membrane) is equal to the part length (longest of the 2 perimeter dimensions).

### ***Setup***

Membrane and carbon cloth materials generally come in standard lengths up to 6000 meters, with 1000 meters being a commonly advertised roll size. Depending on the maximum available roll length, multiple machine setups may be required to process the material for an entire production run. The necessary coated material length is:

$$\text{Material length} = (\text{Part width (mm)} / 1000 \text{ (mm/m)}) \times \text{Batch size (parts)}$$

The required roll length for a batch of parts is:

$$10 \text{ kW: Material length} = (175 / 1000) \times 21,250 = 3719 \text{ meters}$$

$$25 \text{ kW: Material length} = (224 / 1000) \times 26,500 = 5936 \text{ meters}$$

Therefore, the number of setups required for 1000 meter rolls is:

$$\text{Number of setups} = \text{Ceiling}(\text{Material length (m)} / \text{Roll length (m)})$$

$$10 \text{ kW: Number of setups} = \text{Ceiling}(3719 / 1000) = 4$$

$$25 \text{ kW: Number of setups} = \text{Ceiling}(5936 / 1000) = 6$$

Assuming a 1 hour setup time at a labor cost of \$45/hr and overall plant efficiency of 85%, the setup cost per part is:

$$10 \text{ kW: Setup cost} = 4 \times 1 \text{ hr} \times \$45/\text{hr} / 0.85 / 21,250 = \$0.010/\text{part}$$

$$25 \text{ kW: Setup cost} = 6 \times 1 \text{ hr} \times \$45/\text{hr} / 0.85 / 26,500 = \$0.012/\text{part}$$

### ***Tooling***

Tooling consists of the heated platens, which generally consist of 2"-2.5" thick aluminum plates loaded with electric cartridge heaters spaced 3" (7.6 cm) apart. In 2010, DTI estimated the tooling costs to be \$10,913 for 0.5m x 1.5m heated platens. This is in line with a quote received from Custom Engineering Co. (platens.com) for smaller heated platens used for compression molding of bipolar plates.

An engineering estimate for tool life based on heater life would be around 500,000 parts. Using \$11,000 as a basis, tooling costs per part is calculated as:

$$\text{Tooling cost} = \$11,000 / 500,000 \text{ parts} = \$0.02/\text{part}$$



## Material

For volumes equivalent to 1000 stacks, DTI estimated that the gas diffusion layer (GDL) cost is approximately \$95/m<sup>2</sup>. We will assume that the gas diffusion layer (GDL) being pressed onto the membrane is a purchased item in roll form with roll width and length equal to the catalyzed membrane. The cost of the membrane is accounted for in a previous process step, and is not included as part of the hot pressing operation. The material cost per part is calculated as:

$$\text{Material cost} = \text{GDL cost } (\$/\text{m}^2) \times ((\text{Part width (m)} \times \text{Part length (m)}) \times \text{Number of layers})$$

Assuming 2 GDL layers at a cost of \$95/m<sup>2</sup>, the material cost is:

$$10 \text{ kW: Material cost} = \$95/\text{m}^2 \times (409.5 \text{ cm}^2 / 10000) \times 2 = \$7.78/\text{part}$$

$$25 \text{ kW: Material cost} = \$95/\text{m}^2 \times (681 \text{ cm}^2 / 10000) \times 2 = \$12.94/\text{part}$$

## Hot Press

The hot press occurs in two steps: the material is moved into the press (handling time) and the press operation (clamp time). The material handling time is computed using an empirical formula developed by Boothroyd Dewhurst for automated handling with 2.8 second minimum as follows:

$$\text{Handling time} = \text{Max}((0.012 \times (\text{Platen length (cm)} + \text{Platen width (cm)}) + 1.6), 2.8)$$

$$\text{Handling time} = \text{Max}((0.012 \times (150 + 50) + 1.6), 2.8) = 4 \text{ sec}$$

Omega (<http://www.omega.com/prodinfo/cartridgeheaters.html>) estimates 0.5" cartridge heaters to have a watt density of 50W per inch of heater length (about 20W per cm length). Calculating the total input heater power for the platen:

$$\text{Number of heaters} = \text{Ceiling}(\text{Platen length (cm)} / 7.6) = \text{Ceiling}(150 \text{ cm} / 7.6 \text{ cm}) = 20$$

$$\text{Platen power input} = \text{Number of heaters} \times (\text{Platen width (cm)} \times 20 \text{ (W/cm)})$$

$$\text{Platen power input} = 20 \text{ heaters} \times (50 \text{ cm} \times 20 \text{ W/cm}) = 20 \text{ kW}$$

The heated platens need to maintain a temperature during pressing of about 100°C. The energy required to heat the platen at the start of a batch run can be calculated using the heat equation:  $\Delta Q = \rho v c_p \Delta T$ . Assuming a 0.5 x 1.5 x 0.05 meter 6061 aluminum plate heated from 25°C to 100°C:

$$\text{Volume} = 50 \times 150 \times 5 = 37,500 \text{ cm}^3$$

$$\text{Energy} = 2.7 \text{ g/cm}^3 \times 37,500 \text{ cm}^3 \times 0.896 \text{ J/g}\cdot\text{°C} \times 75\text{°C} \times 2.8 \times 10^{-7} \text{ kW}\cdot\text{hr/J} = 1.91 \text{ kW}\cdot\text{hr}$$

Assuming an energy cost of \$0.07/kW-hr and 90% heating efficiency, the cost of heating the platens is about \$0.15; negligible on a per part basis for batches of several thousand parts.

The energy required to maintain the platen temperature throughout the batch run is the combination of conductive and convective heat losses during the pressing operation. The energy required to heat the catalyzed membrane (.0061 cm thickness) and the two GDL layers (0.032 cm thickness) is a function of the material volume along a length of 1.5 m from 25°C to 100°C is:

$$10 \text{ kW: Material volume} = 23.4 \text{ cm} \times 0.07 \text{ cm} \times 150 \text{ cm} = 245.7 \text{ cm}^3$$

$$25 \text{ kW: Material volume} = 30.4 \text{ cm} \times 0.07 \text{ cm} \times 150 \text{ cm} = 319 \text{ cm}^3$$

From the Platinum Catalyst Membrane Coating Process document, we derive the weight of catalyst, membrane and GDL as:

$$10 \text{ kW: Catalyst weight} = 0.515 \text{ g/cm}^3 \times (0.491 \text{ cm}^3 + 0.983 \text{ cm}^3) = 0.759 \text{ g}$$

$$10 \text{ kW: Membrane weight} = 2.2 \text{ g/cm}^3 \times 1.02 \text{ cm}^3 = 2.244 \text{ g}$$

$$10 \text{ kW: GDL weight} = 2 \times (2.2 \text{ g/cm}^3 \times 409.5 \text{ cm}^2 \times 0.032 \text{ cm}) = 57.65 \text{ g}$$

The GDL and membrane will drive the material properties of the pressed material (density = 2.2 g/cm<sup>3</sup>, specific heat = 1.2 J/g-°C):

$$10 \text{ kW: Energy} = 2.2 \text{ g/cm}^3 \times 245.7 \text{ cm}^3 \times 1.2 \text{ J/g-}^\circ\text{C} \times 75^\circ\text{C} \times 2.8 \times 10^{-7} \text{ kW-hr/J} = 0.014 \text{ kW-hr}$$

$$25 \text{ kW: Energy} = 2.2 \text{ g/cm}^3 \times 319 \text{ cm}^3 \times 1.2 \text{ J/g-}^\circ\text{C} \times 75^\circ\text{C} \times 2.8 \times 10^{-7} \text{ kW-hr/J} = 0.018 \text{ kW-hr}$$

Convective heat losses to the air (h = 20 W/m<sup>2</sup>-°C) due to ambient air flow across the plates occurs across the face and edges of the platen:

$$\text{Area} = [(0.5 \times 1.5) + 2 \times (0.5 \times 0.05) + 2 \times (1.5 \times 0.05)] \times 2 \text{ platens} = 1.9 \text{ m}^2$$

$$\text{Energy} = 20 \text{ W/m}^2\text{-}^\circ\text{C} \times 1.9 \text{ m}^2 \times 75^\circ\text{C} = 2.85 \text{ kW}$$

Assuming an energy cost of \$0.07/kW-hr, the cost of keeping the platens hot over a 124 second (0.034 hr) press cycle is:

$$10 \text{ kW: Parts/cycle} = 1.5 / 0.175 = 8.57 \text{ parts/cycle}$$

$$10 \text{ kW: Heater energy cost} = \$0.07/\text{kW-hr} \times (2.864 \text{ kW} \times 0.034 \text{ hr}) / (8.57) = \$0.0008/\text{part}$$

$$25 \text{ kW: Parts/cycle} = 1.5 / 0.224 = 6.7 \text{ parts/cycle}$$

$$25 \text{ kW: Heater energy cost} = \$0.07/\text{kW-hr} \times (2.872 \text{ kW} \times 0.034 \text{ hr}) / (6.7) = \$0.001/\text{part}$$

While energy cost on a per part basis appear negligible, a study conducted by the food service industry, indicates that 3 foot electric griddles with rated energy inputs of 8-16 kW demonstrate a 25% duty cycle in actual use. Given that the power densities are comparable, we will assume a similar usage profile, so that the heater energy cost is:

$$10 \text{ kW: Parts/hour} = 8.57 \text{ parts/cycle} / 0.034 \text{ hours/cycle} = 252 \text{ parts/hour}$$

$$10 \text{ kW: Heater energy cost} = \$0.07/\text{kW-hr} \times (20 \text{ kW} \times 0.25) / (252 \text{ part/hour}) = \$0.0014/\text{part}$$

$$25 \text{ kW: Parts/hour} = 6.7 \text{ parts/cycle} / 0.034 \text{ hours/cycle} = 197 \text{ parts/hour}$$

$$25 \text{ kW: Heater energy cost} = \$0.07/\text{kW-hr} \times (20 \text{ kW} \times 0.25) / (197 \text{ part/hour}) = \$0.0018/\text{part}$$

The primary energy input to run the press is hydraulic pump motor power. Applying a pressure of 70 kg/cm<sup>2</sup> to an area of 7500 cm<sup>2</sup> requires a press capacity of 525,000 kg (580 tons). Presses in this range are generally equipped with 15 kW (20 HP) electric motors. For a 2 minute press time, the energy cost per part is calculated in similar fashion to the heater power usage:

$$10 \text{ kW: Press energy cost} = \$0.07/\text{kW-hr} \times (15 \text{ kW} \times 0.034 \text{ hr}) / (8.57) = \$0.0042/\text{part}$$

$$10 \text{ kW: Total process energy cost} = (\$0.0042 + \$0.0014) / 0.85 = \$0.0066/\text{part}$$

$$25 \text{ kW: Press energy cost} = \$0.07/\text{kW-hr} \times (15 \text{ kW} \times 0.034 \text{ hr}) / (6.7) = \$0.0053/\text{part}$$

$$25 \text{ kW: Total process energy cost} = (\$0.0053 + \$0.0018) / 0.85 = \$0.0084/\text{part}$$

The labor cost to operate the machine is:

$$10 \text{ kW: Labor cost} = \$45/\text{hour} / 252 \text{ parts/hour} / 0.85 = \$0.210/\text{part}$$

$$25 \text{ kW: Labor cost} = \$45/\text{hour} / 197 \text{ parts/hour} / 0.85 = \$0.269/\text{part}$$

The standard machine cost per part is:

$$10 \text{ kW: Machine cost} = \$25/\text{hour} / 252 \text{ part/hour} / 0.85 = \$0.117/\text{part}$$

$$25 \text{ kW: Machine cost} = \$25/\text{hour} / 197 \text{ parts/hour} / 0.85 = \$0.149/\text{part}$$

The total process cost will be the sum of the labor, machine and energy cost divided by the overall plant efficiency:

$$10 \text{ kW: Process cost} = (\$0.0066 + \$0.210 + \$0.117) = \$0.334/\text{part}$$

$$25 \text{ kW: Process cost} = (\$0.0084 + \$0.269 + \$0.149) = \$0.426/\text{part}$$

### ***Die Cutting***

Following hot pressing, the MEA is die cut to final shape as shown:

10 kW MEA:

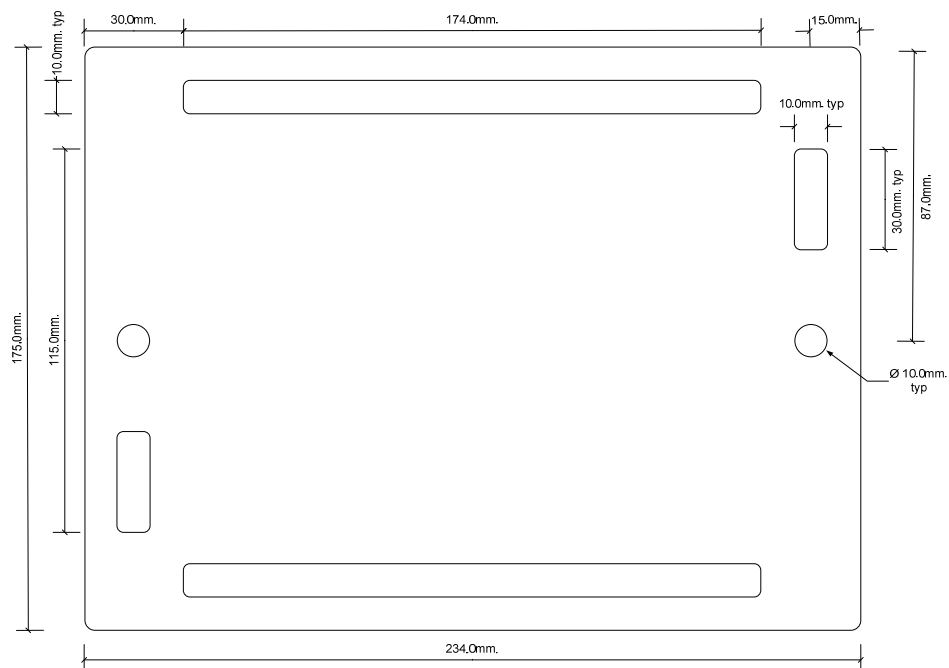

25 kW MEA:

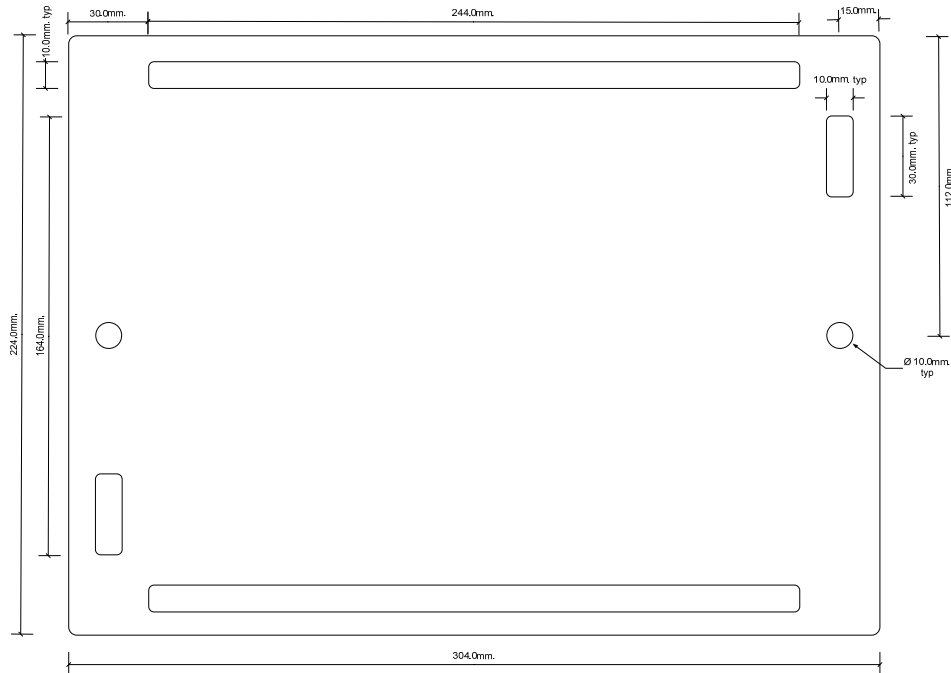

**Tooling**

The primary factor contributing to steel rule die cost is the total cutting length of the die. For the configurations shown above, the cutting length (mm) is:

$$10 \text{ kW: Cutting length} = 2 \times (234 + 175) + 4 \times (174 + 10) + 4 \times (30 + 10) + 2 \times (\pi \times 10) = 1777 \text{ mm}$$

$$25 \text{ kW: Cutting length} = 2 \times (304 + 224) + 4 \times (244 + 10) + 4 \times (30 + 10) + 2 \times (\pi \times 10) = 2295 \text{ mm}$$

A rough quote of approximately \$230 was obtained from steel-rule-dies.com for a two cavity die with a similar configuration.

$$\text{Tooling rate} = \$230 / (2 \times 2706) \text{ mm} = \$0.04/\text{mm}$$

Information obtained from Mag-Knight ([www.mag-knight.com/diecutting/Steel\\_Rule\\_Dies.htm](http://www.mag-knight.com/diecutting/Steel_Rule_Dies.htm)) indicates that dies used to cut softer materials have an expected life of about 30,000 hits. Total tooling cost per part for a 1 cavity die (1 part per stroke) can be calculated as:

$$\text{Tooling cost} = \text{Cutting length (mm)} \times \text{Tooling rate} / \text{Tooling life}$$

$$10 \text{ kW: Tooling cost} = 1777 \text{ mm/die} \times \$0.04/\text{mm} / 30000 \text{ parts} = \$0.002/\text{part}$$

$$25 \text{ kW: Tooling cost} = 2295 \text{ mm/die} \times \$0.04/\text{mm} / 30000 \text{ parts} = \$0.003/\text{part}$$

**Die Cutting**

With the MEA manufactured on a continuous roll lengthwise, 4 parts could be die cut per press stroke given a platen size of 0.5 x 1.0 meters, since 4 parts of the 25 kW MEA would consume 0.9 meters of platen length and 0.3 meters of platen width.

The primary energy input to run the press is hydraulic pump motor power. The total force required to cut the material is the total shear area (cutting length × material thickness) multiplied by the material shear strength. Shear strength data for Nafion® is not readily available, but polymer based materials typically range from 8000 – 11,000 psi (55-76 N/mm<sup>2</sup>). Assuming the worst case shear strength, and using the material thickness of 0.7 mm, the total required press force per part is calculated as:

Press force = Number of cavities × Cutting length (mm) × Material thickness (mm) × Shear strength (N/mm<sup>2</sup>)

$$10 \text{ kW: Press force} = 4 \times 1777 \text{ mm/die} \times 0.7 \text{ mm} \times 76 \text{ N/mm}^2 = 378.15 \text{ kN} = 42.48 \text{ tons}$$

$$25 \text{ kW: Press force} = 4 \times 2295 \text{ mm/die} \times 0.7 \text{ mm} \times 76 \text{ N/mm}^2 = 488.38 \text{ kN} = 54.85 \text{ tons}$$

A survey of 15 to 100 ton (150 – 1000 kN) fast-acting die cutting presses found that the motor power required to operate the press fell in the range of 0.015 – 0.025 kW/kN. Assuming a 50% capacity margin and using the upper end of the motor power rating, the maximum required press energy input is:

$$\text{Press energy} = 488.38 \text{ kN} \times 1.5 \times 0.025 \text{ kW/kN} = 18.3 \text{ kW}$$

The cost of energy usage to operate the press is calculated as:

$$\text{Press energy rate per part} = \$0.07/\text{kW-hr} \times 17.68 \text{ kW} / 4 = \$0.32/\text{hr}$$

Typical die cutting press speed ranges from 30 – 60 cycles/min (1800 – 3600 cycles/hour). Assuming the slower speed, the time to process a batch of parts is calculated as

$$\text{Batch processing time} = \text{Batch size (parts)} / \text{Cycles per hour}$$

$$10 \text{ kW: Batch processing time} = 21,250 \text{ parts} / 4 \text{ parts/cycle} / 1800 \text{ cycle/hour} = 2.95 \text{ hours}$$

$$25 \text{ kW: Batch processing time} = 26,500 \text{ parts} / 4 \text{ parts/cycle} / 1800 \text{ cycle/hour} = 3.68 \text{ hours}$$

The total machine cost per part is calculated as the press energy cost (\$/hr) plus the standard machine cost (\$/hr) multiplied by the batch processing time and divided by the overall plant efficiency and batch size:

$$10 \text{ kW: Machine cost} = ((\$0.32/\text{hr} + \$25/\text{hr}) \times 2.95 \text{ hours}) / 0.85 / 21,250 \text{ parts} = \$0.004/\text{part}$$

$$25 \text{ kW: Machine cost} = ((\$0.32/\text{hr} + \$25/\text{hr}) \times 3.68 \text{ hours}) / 0.85 / 26,500 \text{ parts} = \$0.004/\text{part}$$

The total labor cost per part is calculated as the number of operators per machine multiplied by the labor rate (\$/hr) and batch processing time and divided by the overall plant efficiency and batch size:

$$10 \text{ kW: Labor cost} = (1 \text{ operator} \times \$45/\text{hr} \times 2.95 \text{ hours}) / 0.85 / 21,250 \text{ parts} = \$0.007/\text{part}$$

$$25 \text{ kW: Labor cost} = (1 \text{ operator} \times \$45/\text{hr} \times 3.68 \text{ hours}) / 0.85 / 26,500 \text{ parts} = \$0.007/\text{part}$$

## A.5 Membrane/Catalyst Manufacturing Process Documentation

### *Model Approach*

- Catalyst ink preparation operation
  - Machine setup labor cost based on input labor time; default = 1 hour
  - Compute required batch size based on part batch size and catalyst loading
  - Compute catalyst ink material cost

- Compute catalyst ink processing cost based on material handling time and batch milling time
  - Compute total cost to create catalyst ink batch
- Anode catalyst ink spray deposition to membrane operation
  - Compute processing time based on batch size and substrate speed
  - Compute number of setups based on purchased roll length
  - Compute setup labor cost based on input labor time per setup (default = 1 hour) and number of setups required to process batch
  - Compute material cost based on substrate cost and ink deposition rate
  - Compute required heater area based on drying time and substrate speed
  - Compute heater energy cost based on energy watt density and energy cost
- Cathode catalyst ink spray deposition to transfer substrate operation
  - Compute processing time based on batch size and substrate speed
  - Compute number of setups based on purchased roll length
  - Compute setup labor cost based on input labor time per setup (default = 1 hour) and number of setups required to process batch
  - Compute material cost based on substrate cost and ink deposition rate
  - Compute required heater area based on drying time and substrate speed
  - Compute heater energy cost based on energy watt density and energy cost
- Cathode catalyst ink decal transfer calendaring operation
  - Compute processing time based on batch size and substrate speed
  - Compute number of setups based on purchased roll length
  - Compute setup labor cost based on input labor time per setup (default = 1 hour) and number of setups required to process batch

## Process Flow

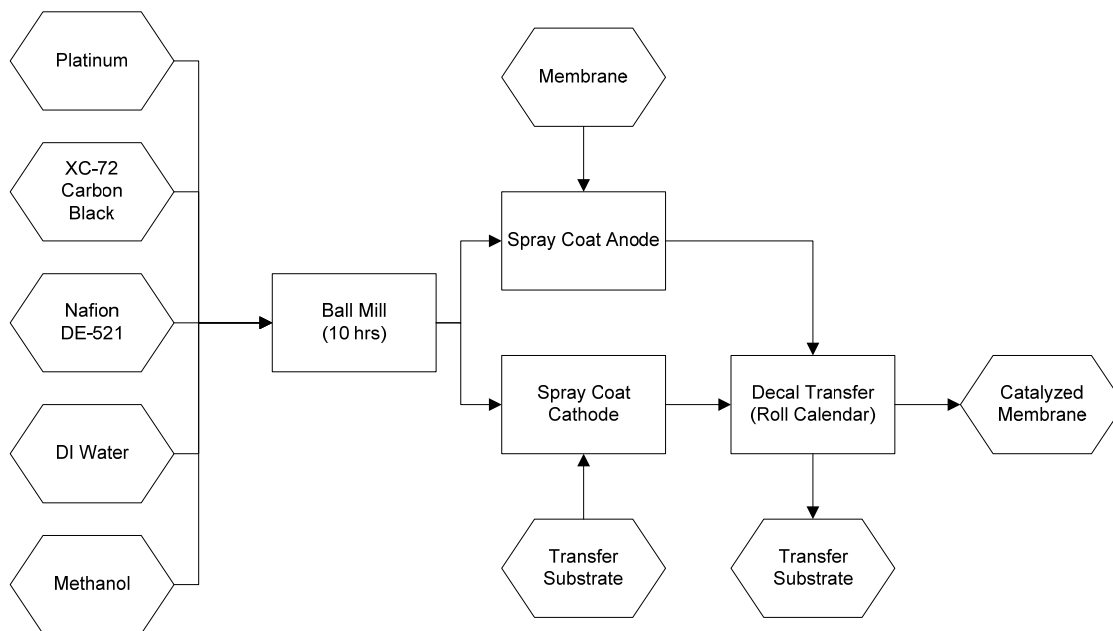

**Figure A-7. Membrane / Catalyst Manufacturing Process**

## Background

In their March, 2009 report, Directed Technologies, Inc. (DTI) reported that the wet platinum catalyst composition as specified in US Patent 7,141,270 consists of:

- 6 wt% Pt
- 9 wt% Vulcan XC-72 (carbon black)
- 72 wt% Nafion® DE-521 solution (5 wt% Nafion®)
- 6.5 wt% DI water
- 6.5 wt% methanol

DTI also reported that, assuming that all solvents are driven off during the drying process, the dry catalyst consists of:

- 48.4 wt% Vulcan XC-72 (carbon black)
- 32.3 wt% Pt
- 19.4 wt% Nafion®

While DTI assumed that the ink slurry was mixed using ultrasonic processing, technical literature and conversations with stack manufactures indicates that ball milling is used as the primary means of grinding and homogenizing the catalyst ink, with milling times reported in the range of 4 hours to “overnight.” US Patent 6,187,468 details a two-step preparation process of mixing (milling) for 60 to 300 minutes, followed by 30 to 300 minutes in a “three-dimensional vibrating stirrer.” Constant processing in a regular or planetary ball mill for 8-10 hours may suffice for both the mixing and stirring parts of the process.

Manufacturers indicate that production runs occur on a quarterly basis, and that, depending on demand, batch sizes are sufficient for production in the range of 25,000 to 50,000 cells. Manufacturers also noted that there are significant losses during the ink production process, which tends to occur when handling ink/slurry from one part of the process to the next (e.g. transfer of final composition from mixing vessel to catalyst application method apparatus).

Manufactures noted that past, low-volume catalyst application was performed using screen printing, but that the current process is generally done roll-to-roll. At least one approach involves a two step process. One catalyst layer is applied directly to the membrane. The membrane is then turned over, and the second catalyst layer is applied by hot press decal transfer. The actual application method can be either tape casting, spray deposition or die slot coating.

### ***Preliminary Analysis***

#### ***Batch Volume***

Catalyst batch volume depends on the coated area, catalyst loading, and membrane electrode assembly (MEA) batch size.

The cells for this analysis will be working in two systems for which the size of the coated area is:

$$10 \text{ kW Stack: } 175 \text{ mm width} \times 234 \text{ mm length} = 409.5 \text{ cm}^2$$

$$25 \text{ kW Stack: } 224 \text{ mm width} \times 304 \text{ mm length} = 681 \text{ cm}^2$$

Material densities for the catalyst components are as follows:

$$\rho(\text{Pt}) = 21.45 \text{ g/cm}^3$$

$$\rho(\text{XC-72}) = 0.264 \text{ g/cm}^3$$

$$\rho(\text{Nafion}^\circledast \text{ DE-521}) = 1.05 \text{ g/cm}^3$$

$$\rho(\text{DI water}) = 1.0 \text{ g/cm}^3$$

$$\rho(\text{methanol}) = 0.792 \text{ g/cm}^3$$

Based on the wet platinum catalyst composition as specified above, 100 grams of wet catalyst contains 6 grams of Pt and has a volume of:

$$v = (6/21.45) + (9/0.264) + (72/1.05) + (6.5/0.792) + (6.5/1) = 117.6 \text{ cm}^3$$

Yielding a wet catalyst density of:

$$\rho(\text{wet catalyst}) = (100/117.6) = 0.85 \text{ g/cm}^3$$

The Pt content of the wet catalyst is:

$$m(\text{Pt})/v(\text{wet catalyst}) = 6/117.6 = 0.051 \text{ g/cm}^3 = 51 \text{ mg/cm}^3$$

To obtain a loading of  $1 \text{ mg/cm}^2$ , the depth of the wet catalyst layer is:

$$d(\text{wet catalyst}) = 1/51 = 0.02 \text{ cm} = 200 \text{ microns}$$

Based on the dry platinum catalyst composition as specified above, 100 grams of dry catalyst contains 32.3 grams of Pt and has a volume of:

$$v = (32.3/21.45) + (48.4/0.264) + (19.4/2.05) = 194.3 \text{ cm}^3$$

Yielding a dry catalyst density of:

$$\rho(\text{dry catalyst}) = (100/194.3) = 0.515 \text{ g/cm}^3$$

The Pt content of the dry catalyst is:

$$m(\text{Pt})/v(\text{dry catalyst}) = 32.3/194.3 = 0.166 \text{ g/cm}^3 = 166 \text{ mg/cm}^3$$

To obtain a loading of  $1 \text{ mg/cm}^2$ , the depth of the dry catalyst layer is:



$$d(\text{dry catalyst}) = 1/166 = 0.006 \text{ cm} = 60 \text{ microns}$$

Typical Pt loadings of 0.2 and 0.4 mg/cm<sup>2</sup> will require wet deposition to depths of 40 and 80 microns, respectively, resulting in dry layer depths of 12 and 24 microns, respectively. Therefore, to coat both sides of the membrane with a total loading 0.6 mg/cm<sup>2</sup> will require a total coated depth of 120 microns (0.012 cm):

$$10 \text{ kW: Wet catalyst weight} = 0.85 \text{ g/cm}^3 \times (409.5 \times 0.012) \text{ cm}^3 \times 0.001 \text{ kg/g} = 0.0042 \text{ kg/part}$$

$$25 \text{ kW: Wet catalyst weight} = 0.85 \text{ g/cm}^3 \times (681 \times 0.012) \text{ cm}^3 \times 0.001 \text{ kg/g} = 0.0069 \text{ kg/part}$$

Batch sizes will be calculated based on a quarterly production schedule producing 1,000 stacks per year. The 10 kW stack requires 85 cells, requiring quarterly production of:

$$10 \text{ kW: Quarterly production} = 85 \text{ parts/stack} \times 250 \text{ stacks} = 21,250 \text{ parts}$$

$$\text{Catalyst batch size} = 21,250 \text{ parts} \times 0.0042 \text{ kg/part} = 89.25 \text{ kg}$$

The 25 kW stack requires 106 cells, requiring quarterly production of:

$$25 \text{ kW: Quarterly production} = 106 \text{ parts/stack} \times 250 \text{ stacks} = 26,500 \text{ parts}$$

$$\text{Catalyst batch size} = 26,500 \text{ parts} \times 0.0069 \text{ kg/part} = 182.85 \text{ kg}$$

### ***Catalyst Ink Material Cost***

Material cost of the ink is calculated using the weight percents of the slurry constituents multiplied by the raw material cost to determine a cost per kilogram. Platinum cost is assumed to be equal to the open market spot price, which was \$1,390/tr.oz. (\$44,695/kg) on 8/10/2012. Quotes for Nafion® DE-521 in bulk supply are difficult to obtain. In 2010, DTI estimated that \$2,200/kg was a reasonable estimate for the volumes required to make 90 to 180 kg batches of catalyst. Bulk costs for XC-72 and Methanol were obtained from alibaba.com in August, 2012. The cost of DI water is based on distillation costs from [www.apswater.com](http://www.apswater.com) in September, 2012. Summarizing:

Platinum: \$44,695/kg

Nafion® DE-521: \$2,200/kg

Vulcan XC-72: \$18/kg

Methanol: \$0.50/kg

DI Water: \$0.11/kg

The cost of the ink is:

$$\text{Material cost} = (0.06 \times 44,695) + (0.72 \times 2,200) + (0.09 \times 18) + (0.065 \times 0.50) + (0.065 \times 0.11)$$

$$\text{Material cost} = \$4,267.36/\text{kg} = \$4.267/\text{g}$$

As shown above, a Pt loading of 1 mg/cm<sup>2</sup> requires a 200 micron thick layer of ink. Ink cost per part is:

$$\text{Material cost/part} = \text{Cost of ink (\$/g)} \times \text{Ink density (g/cm}^3) \times \text{Part width (cm)} \times \text{Part length (cm)} \\ \times (\text{Pt loading (mg/cm}^2) \times 0.02 \text{ cm/(mg/cm}^2))$$

For a total Pt loading of 0.6 mg/cm<sup>2</sup>, the cost per part would be:

$$10 \text{ kW: Material cost/part} = \$4.267/\text{g} \times 0.85 \text{ g/cm}^3 \times 409.5 \text{ cm}^2 \times 0.6 \text{ mg/cm}^2 \times 0.020 \\ \text{cm/(mg/cm}^2) = \$17.82/\text{part}$$

$$25 \text{ kW: Material cost/part} = \$4.267/\text{g} \times 0.85 \text{ g/cm}^3 \times 681 \text{ cm}^2 \times 0.6 \text{ mg/cm}^2 \times 0.020 \text{ cm}/(\text{mg/cm}^2) \\ = \$29.64/\text{part}$$

### ***Catalyst Ink Processing Cost***

The first step is to weigh the materials out and place them in the mill. We will assume a manual process consisting of a measurement step and a material handling step. The BDI DFMA<sup>®</sup> software contains an analogous operation for off-line precision measurement with a default value of 17.4 seconds for the measurement, and a minimum of 4 seconds for material handling. The catalyst ink is made up of 5 materials, so that total handling time for material preparation can be estimated as:

$$\text{Material prep time} = 5 \times 21.4 \text{ sec} = 107 \text{ sec} = 1.8 \text{ minutes}$$

The primary cost for operating the ball mill is the energy input to the motor running the mill. Some studies have looked into the cost of operating large ball mills used for cement and powder metallurgy material processing, where the target parameter is the amount of energy required to process a given amount of material, usually expressed in kW-hr/ton. The calculations are complex owing to the large number of inputs to the calculations.

In “Technical Notes 8, Grinding,” R. P. King develops a relationship based on fundamental physical models of ball mill processing to determine mill power based on mill diameter, assuming that the length is twice the diameter, and that fairly standard values for loading apply. He presents a log-log plot showing that a mill with a diameter of 1 meter will consume about 10 kW of power, where a mill with a diameter of 2 meters consumes about 100 kW. These two values yield the equation:

$$\text{Power} = 10d^{3.32} \text{ kW}$$

His values assume a 35% volumetric loading ratio, giving a total charge volume of:

$$\text{Charge volume} = (\pi \times d^2 / 4) \times 2d \times 0.35 = 0.175 \pi d^3 \text{ m}^3$$

In addition, he assumes that the volume of milling balls represents 10% of the total charge volume. Therefore, assuming 90% of the charge volume is catalyst material, we can state that:

$$\text{Catalyst volume} = 1.11 \times (\text{Catalyst weight (kg)} / \text{Catalyst density (kg/m}^3)) = 0.175 \pi d^3$$

Solving for d:

$$d = (2.02 \times (\text{Catalyst weight (kg)} / \text{Catalyst density (kg/m}^3)))^{1/3}$$

To compute the power required to process a batch of catalyst with a density of 850 kg/m<sup>3</sup>, we find the theoretical diameter of the fully loaded mill as:

$$10 \text{ kW: } d = (2.02 \times 89.25 \text{ kg} / 850 \text{ kg/m}^3)^{1/3} = 0.596 \text{ meters}$$

$$25 \text{ kW: } d = (2.02 \times 182.85 \text{ kg} / 850 \text{ kg/m}^3)^{1/3} = 0.757 \text{ meters}$$

Plugging the theoretical diameter into the power equation we have:

$$10 \text{ kW: Power} = 10 \times (0.596)^{3.32} = 1.794 \text{ kW}$$

$$25 \text{ kW: Power} = 10 \times (0.757)^{3.32} = 3.968 \text{ kW}$$

Assuming an energy cost of \$0.07/kW-hr and a milling time of 10 hours, the cost of powering the mill is:

$$10 \text{ kW: Power cost} = 0.07 \times 1.794 \times 10 = \$1.26$$

$$25 \text{ kW: Power cost} = 0.07 \times 3.968 \times 10 = \$2.78$$

King's derived data only goes as low as mills with about 1.2 kW of input power, relating to a diameter of approximately 0.5 meters. A web search of smaller ball mills and found a listing for a 100 lb (45 kg) charge capacity mill powered by a 1.5 HP (1.1 kW) electric motor having a diameter of 12" and length of 24". It seems reasonable to assume a 1.5 kW minimum for ball mill power consumption.

Once process is complete, the catalyst ink will need to be separated from the milling balls and transferred to the coating machine. While we presently have no information about this part of the process, one approach would be the use of a vacuum sieve (e.g., Farleygreene, Ltd. SM950 Sievmaster Vacu-siev) to remove and separate the catalyst ink from the mill, and transfer the ink to a transport container or directly to the coater reservoir.

ShopVac reports a sealed suction of 54 in-H<sub>2</sub>O (13.4 kPa) for their 2 HP (1.5 kW) unit. Using an equivalent vacuum sieve with a 1.5" (0.038 m) diameter hose and 80% transfer efficiency, the flow rate is:

$$\text{Flow rate} = 0.8 \times (\pi \times (0.038)^2 / 4) \times (2 \times 13.4 / 850)^{1/2} = 0.00016 \text{ m}^3/\text{sec}$$

Since the catalyst forms 90% of the charge volume, the total charge volume of:

$$\text{Charge volume (m}^3\text{)} = 1.11 \times (\text{Catalyst weight (kg)} / \text{Catalyst density (kg/ m}^3\text{)})$$

$$\text{Charge volume (m}^3\text{)} = 0.0013 \times \text{Catalyst weight}$$

Therefore, the optimal time required to remove the charge volume is:

$$\text{Material removal time (sec)} = \text{Charge volume} / \text{Flow rate} = 8.1 \times \text{Catalyst weight}$$

The optimal time to remove a batch of catalyst from the mill would be:

$$10 \text{ kW: Material removal time} = 8.1 \times 89.25 = 723 \text{ sec} = 12 \text{ minutes}$$

$$25 \text{ kW: Material removal time} = 8.1 \times 182.85 = 1481 \text{ sec} = 24.7 \text{ minutes}$$

We will estimate the total transfer time to remove the ink from the mill and transfer it to the coater as twice the ink removal time.

Assuming an overall plant efficiency of 85% for machine and labor time, the total processing cost for a 300 kg batch is:

$$\text{Process cost} = \text{Power cost} + [(\text{Milling time} \times \text{Machine rate}) + ((\text{Material prep time} + \text{Material removal time}) \times \text{Labor rate})] / \text{Overall plant efficiency}$$

$$10 \text{ kW: Process cost} = \$1.26 + [(10 \text{ hours} \times \$25/\text{hour}) + ((0.03 + 0.40) \text{ hours} \times \$45/\text{hour})] / 0.85 = \$318.14$$

$$25 \text{ kW: Process cost} = \$2.78 + [(10 \text{ hours} \times \$25/\text{hour}) + ((0.03 + 0.82) \text{ hours} \times \$45/\text{hour})] / 0.85 = \$341.90$$

The processing cost per part is:

$$10 \text{ kW: Process cost/part} = 318.14 / 21250 = \$0.015/\text{part}$$

$$25 \text{ kW: Process cost/part} = 341.90 / 26500 = \$0.013/\text{part}$$

### ***Catalyst Ink Deposition***

As indicated previously, one approach to catalyst deposition involves a two step process. One catalyst layer is applied directly to the membrane. The membrane is then turned over, and the second catalyst layer is applied by hot press decal transfer. Both the membrane application and decal creation are direct deposition processes to a substrate material; one being the membrane itself, and the other to a carrier substrate, commonly a polyester or polyimide material.

We will assume a spray coating application process with coating width is equal to the part length (longest of the 2 perimeter dimensions) in order to minimize the roll length needed to produce a batch of parts.

The necessary coated material length is:

$$\text{Material length} = (\text{Part width (mm)} / 1000 \text{ (mm/m)}) \times \text{Batch size (parts)}$$

The required roll length for a batch of parts is:

$$10 \text{ kW: Material length} = (175 / 1000) \times 21,250 = 3719 \text{ meters}$$

$$25 \text{ kW: Material length} = (224 / 1000) \times 26,500 = 5936 \text{ meters}$$

It should be noted that roll material is usually sold in standard lengths and widths. Widths tend to be either 0.4 or 0.8 meters, while lengths can be found up to a maximum of about 6000 meters for more common thin films (polyimide, polyethylene), and up to 1000 meters for membrane and carbon cloth materials. Depending on the maximum available roll length, multiple machine setups may be required to process the material for an entire production run, which is calculated as:

$$\text{Number of setups} = \text{Ceiling}(\text{Material length (m)} / \text{Roll length (m)})$$

$$10 \text{ kW: Number of setups} = \text{Ceiling}(3719 / 1000) = 4$$

$$25 \text{ kW: Number of setups} = \text{Ceiling}(5936 / 1000) = 6$$

Assuming a 1 hour setup time at a labor cost of \$45/hr and overall plant efficiency of 85%, the setup cost per part is:

$$10 \text{ kW: Setup cost} = 4 \times 1 \text{ hr} \times \$45/\text{hr} / 0.85 / 21,250 = \$0.010/\text{part}$$

$$25 \text{ kW: Setup cost} = 6 \times 1 \text{ hr} \times \$45/\text{hr} / 0.85 / 26,500 = \$0.012/\text{part}$$

### ***Spray Deposition***

While the material processing time for spray deposition is calculated in the same way, the substrate speed is not an input, but is instead a function of the depth of catalyst deposition and nozzle flow rate.

A fan-shaped spray deposits the ink across a narrow rectangular area as shown.

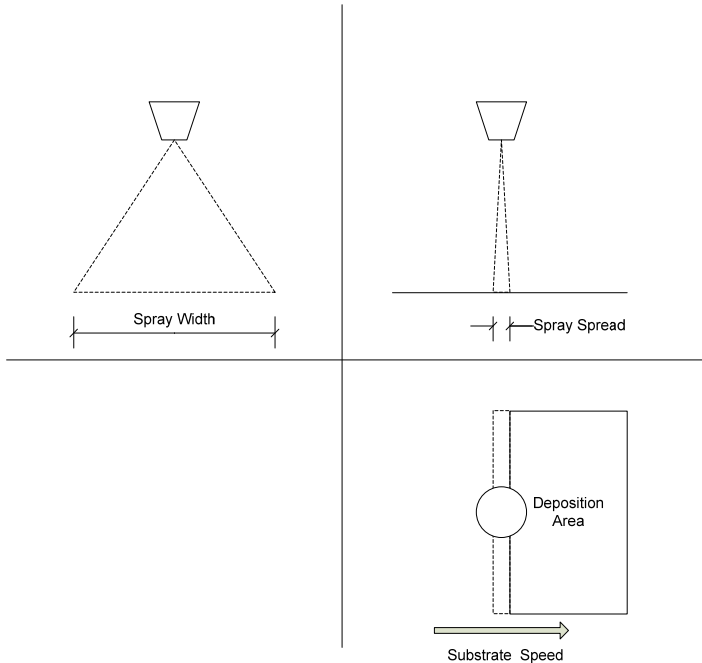

Assuming that the spray spread is minimal, we can model the deposition as occurring in a line moving across the substrate resulting in a rectangular deposition area. Deposited depth is:

$$\text{Coating depth} = \text{Flow rate (mm}^3/\text{sec)} / (\text{Spray width (mm)} \times \text{Substrate speed (mm/sec)})$$

Spray nozzle manufacturers will generally specify a maximum flow rate associated with a particular nozzle. Therefore, given a flow rate, coated width and coating depth, the substrate speed is calculated as:

$$\text{Substrate speed (mm/sec)} = \text{Flow rate (mm}^3/\text{sec)} / (\text{Spray width (mm)} \times \text{Coating depth (mm)})$$

Using the SonoTek Flexicoat Impact nozzle system as an example, the maximum precision spray width is approximately 50 mm. Assuming an ink flow rate of 333 mm<sup>3</sup>/sec (20 ml/min), the substrate speed is:

$$40 \text{ micron depth: Substrate speed} = 333 / (50 \times 0.04) = 166.5 \text{ mm/sec} = 10 \text{ m/min}$$

$$80 \text{ micron depth: Substrate speed} = 333 / (50 \times 0.08) = 83.25 \text{ mm/sec} = 5 \text{ m/min}$$

Theoretically, the number of nozzles required to cover the coated width is simply the coated width divided by the spray width. For the SonoTek nozzle, this gives:

$$10 \text{ kW: Number of nozzles} = \text{Ceiling}(234 / 50) = 5 \text{ nozzles}$$

$$25 \text{ kW: Number of nozzles} = \text{Ceiling}(304 / 50) = 7 \text{ nozzles}$$

Assuming a standard delivery pressure of 2 bar (200 kPa) and transfer efficiency of 80%, the power required to drive the ink pump feeding a maximum of 7 nozzles is:

$$\text{Pump power} = 200,000 \text{ Pa} \times ((3.3 \times 10^{-7}) \text{ m}^3/\text{sec} \times 7) / 0.8 = 0.58 \text{ W}$$

Therefore, the cost of power to drive the spray pump will be negligible relative to the standard machine cost.

Note that deposition does tend to higher in the center of the spray and thin out at the edges. Lechler, a manufacturer of precision fan-shaped spray nozzles, recommends a 1/3 to 1/4 spray area overlap for even coverage. Assuming a 30% overlap on each edge, the effective coverage for a single nozzle is 40% of the stated spray width. For calculating tooling cost, the number of nozzles required is:

$$\text{Number of nozzles} = \text{Ceiling}(\text{Coated width (mm)} / ((\text{Spray width (mm)} \times 0.4)))$$

For a coated width of 360 mm, the number of nozzles required will be:

$$10 \text{ kW: Number of nozzles} = \text{Ceiling}(234 / (50 \times 0.4)) = 12$$

$$25 \text{ kW: Number of nozzles} = \text{Ceiling}(304 / (50 \times 0.4)) = 16$$

We will assume that ink flow rate will be tweaked to account for higher center volumes.

### ***Material***

We will assume that the anode layer is deposited directly onto the membrane, while the cathode layer is deposited on a transfer substrate. For volumes equivalent to 1000 stacks, DTI estimated that the membrane cost is approximately \$224.45/m<sup>2</sup>. The transfer substrate usually consists of a polyester or polyimide material to permit release of the cathode layer during the calendaring process. Polyester is the more cost effective material at around \$5/m<sup>2</sup>. The material cost per part is calculated as:

$$\text{Material\_cost} = \text{Material cost (\$/m}^2) \times ((\text{Part width (m)} \times \text{Part length (m)}))$$

The material cost is:

$$10 \text{ kW membrane: Material\_cost} = \$224.45/\text{m}^2 \times 409.5 \text{ cm}^2 / 10000 = \$9.19/\text{part}$$

$$10 \text{ kW transfer substrate: Material\_cost} = \$5/\text{m}^2 \times 409.5 \text{ cm}^2 / 10000 = \$0.205/\text{part}$$

$$25 \text{ kW membrane: Material\_cost} = \$224.45/\text{m}^2 \times 681 \text{ cm}^2 / 10000 = \$15.28/\text{part}$$

$$25 \text{ kW transfer substrate: Material\_cost} = \$5/\text{m}^2 \times 681 \text{ cm}^2 / 10000 = \$0.341/\text{part}$$

### ***Catalyst Ink Drying***

Following deposition, the catalyst ink is dried, usually by means of a tunnel dryer positioned directly after the deposition step. The drying can be done by either radiant or convective heating. For the cost analysis, we will assume radiant (infrared) heating and compute the cost of drying by determining the required heater area based on the substrate speed and the drying time.

Infrared heating panels are generally sold with various energy watt densities and in standard sized units and assembled to provide the necessary heating area. Using the Casso Solar Type FB as an example, standard watt densities are 15 and 25 W/in<sup>2</sup> (23 and 39 kW/m<sup>2</sup>) with standard width of 12" (0.305 m) and lengths in 12" increments up to 60" (1.524 m). They note that 25 W/in<sup>2</sup> corresponds to an emitter temperature of 880°C, and that the conversion efficiency of electrical power to usable radiant energy is up to 80%.

Most catalyst drying studies use oven drying. Times anywhere from 10 minutes at 400°F (204°C) to 25 minutes at 80°C are reported. Silverman, et.al., in "Modeling of a Fuel Cell Catalyst Coating and Drying Process" (2010) suggest that a drying time of 2 minutes can be achieved in a continuous process at 80°C and low relative humidity.

For costing purposes, we will take drying time as an input and use the substrate speed and part width to compute the theoretical required heater area.

$$\text{Heater area} = \text{Drying time (min)} \times \text{Substrate speed (m/min)} \times (\text{Part width (mm)} / 1000)$$

For a drying time of 2.5 minutes for a 40 micron depth and 5 minutes for 80 micron depth, the theoretical required heater area as:

$$10 \text{ kW, 40 micron depth: Heater area} = 2.5 \times 10 \times (234 / 1000) = 5.85 \text{ m}^2$$

$$10 \text{ kW, 80 micron depth: Heater area} = 5 \times 5 \times (234 / 1000) = 5.85 \text{ m}^2$$

$$25 \text{ kW, 40 micron depth: Heater area} = 2.5 \times 10 \times (304 / 1000) = 7.6 \text{ m}^2$$

$$25 \text{ kW, 80 micron depth: Heater area} = 5 \times 5 \times (304 / 1000) = 7.6 \text{ m}^2$$

While the heater energy density will be taken as an input, the drying temperatures for the catalyst are fairly moderate, so that the 23 kW/m<sup>2</sup> should be sufficient to maintain the drying area temperature. Using an energy cost of \$0.07/kW-hr, the hourly energy cost to power the heaters will be:

$$10 \text{ kW: Heating cost/hour} = 5.85 \text{ m}^2 \times 23 \text{ kW/m}^2 \times \$0.07/\text{kW-hr} = \$9.41/\text{hour}$$

$$25 \text{ kW: Heating cost/hour} = 7.6 \text{ m}^2 \times 23 \text{ kW/m}^2 \times \$0.07/\text{kW-hr} = \$12.24/\text{hour}$$

The process cost per part associated with the drying operation is calculated based on the throughput in part/hour, which is a function of substrate speed and part length as follows:

$$\text{Heating cost/part} = \text{Heating cost/hour (\$/hr)} \times (\text{Part length (mm)} / 1000) / (\text{Substrate speed (m/min)} \times 60 \text{ min/hr})$$

$$10 \text{ kW, 40 micron depth: Heating cost/part} = 9.41 \times (234 / 1000) / (10 \times 60) = \$0.004/\text{part}$$

$$10 \text{ kW, 80 micron depth: Heating cost/part} = 9.41 \times (234 / 1000) / (5 \times 60) = \$0.007/\text{part}$$

$$25 \text{ kW, 40 micron depth: Heating cost/part} = 12.24 \times (304 / 1000) / (10 \times 60) = \$0.006/\text{part}$$

$$25 \text{ kW, 80 micron depth: Heating cost/part} = 12.24 \times (304 / 1000) / (5 \times 60) = \$0.012/\text{part}$$

### ***Catalyst Layer Decal Transfer***

At least one approach involves a two step process. One catalyst layer is applied directly to the membrane. The membrane is then turned over, and the second catalyst layer is applied by hot press decal transfer. The roll-to-roll hot press operation can be either a semi-continuous process where the material is indexed into a standard heated platen press (see DTI, Mass Production Cost Estimation for Direct H2 PEM Fuel Cell Systems for Automotive Applications: 2010 Update, Section 4.4.6.1) or by pre-heating and passing through heated rollers in a calendaring process. For the preliminary analysis we will assume a calendaring process

The calendaring process consists of 2 main steps: preheating and rolling. We will assume that the coated membrane and decal catalyst layers are brought together and passed through an infrared tunnel oven for preheating. Assuming that the two layers need to reach 100°C, we can estimate the oven dwell time as (noting that 1 W = 1 J/sec):

$$\text{Oven dwell time} = \text{Part weight (g)} \times \text{Part specific heat (J/g-}^\circ\text{C)} \times \text{Temperature rise (}^\circ\text{C)} / \text{Energy input (W)}$$

If we assume that the same infrared heaters used for drying are used for preheating, the energy rate impinging on the part is:

$$\text{Energy input} = \text{Heater watt density (W/cm}^2\text{)} \times \text{Part width (cm)} \times \text{Part length (cm)} \times$$

Energy transfer efficiency

$$10 \text{ kW: Energy input} = 2.3 \text{ W/cm}^2 \times 17.5 \text{ cm} \times 23.4 \text{ cm} \times 0.80 = 753.5 \text{ W}$$

$$25 \text{ kW: Energy input} = 2.3 \text{ W/cm}^2 \times 22.4 \text{ cm} \times 30.4 \text{ cm} \times 0.80 = 1,253 \text{ W}$$

Common polymers (PTFE, polyester, polyimide) have specific heats in the range of 1.1-1.3 J/g-°C and densities around 2.2 g/cm<sup>3</sup>. Specific heat capacities of the dry catalyst constituents are:

Nafion: 4.2 J/g-°C

Platinum: 0.13 J/g-°C

Carbon black: 4.18 J/g-°C

The specific heat of the catalyst is:

$$\text{Catalyst specific heat} = (0.194 \times 4.2) + (0.323 \times 0.13) + (0.484 \times 4.18) = 2.88 \text{ J/g-}^\circ\text{C}$$

The volume of dry catalyst for the anode and cathode per part are:

$$10 \text{ kW: Anode dry catalyst volume} = 409.5 \text{ cm}^2 \times 0.0012 \text{ cm} = 0.491 \text{ cm}^3$$

$$10 \text{ kW: Cathode dry catalyst volume} = 409.5 \text{ cm}^2 \times 0.0024 \text{ cm} = 0.983 \text{ cm}^3$$

$$25 \text{ kW: Anode dry catalyst volume} = 681 \text{ cm}^2 \times 0.0012 \text{ cm} = 0.817 \text{ cm}^3$$

$$25 \text{ kW: Cathode dry catalyst volume} = 681 \text{ cm}^2 \times 0.0024 \text{ cm} = 1.63 \text{ cm}^3$$

The volume of substrate material (25 micron thickness) per part is:

$$10 \text{ kW: Membrane volume} = 409.5 \text{ cm}^2 \times 0.0025 \text{ cm} = 1.02 \text{ cm}^3$$

$$25 \text{ kW: Membrane volume} = 681 \text{ cm}^2 \times 0.0025 \text{ cm} = 1.70 \text{ cm}^3$$

The oven dwell time for each is then (dry catalyst density = 0.515 g/cm<sup>3</sup>):

$$10 \text{ kW: Anode oven dwell time} = ((2.2 \text{ g/cm}^3 \times 1.02 \text{ cm}^3 \times 1.2 \text{ J/g-}^\circ\text{C}) + (0.515 \text{ g/cm}^3 \times 0.491 \text{ cm}^3 \times 2.88 \text{ J/g-}^\circ\text{C})) \times 75^\circ\text{C} / 753.5 \text{ W} = 0.34 \text{ sec}$$

$$10 \text{ kW: Cathode oven dwell time} = ((2.2 \text{ g/cm}^3 \times 1.02 \text{ cm}^3 \times 1.2 \text{ J/g-}^\circ\text{C}) + (0.515 \text{ g/cm}^3 \times 0.983 \text{ cm}^3 \times 2.88 \text{ J/g-}^\circ\text{C})) \times 75^\circ\text{C} / 753.5 \text{ W} = 0.41 \text{ sec}$$

$$25 \text{ kW: Anode oven dwell time} = ((2.2 \text{ g/cm}^3 \times 1.02 \text{ cm}^3 \times 1.2 \text{ J/g-}^\circ\text{C}) + (0.515 \text{ g/cm}^3 \times 0.817 \text{ cm}^3 \times 2.88 \text{ J/g-}^\circ\text{C})) \times 75^\circ\text{C} / 1,253 \text{ W} = 0.23 \text{ sec}$$

$$25 \text{ kW: Cathode oven dwell time} = ((2.2 \text{ g/cm}^3 \times 1.02 \text{ cm}^3 \times 1.2 \text{ J/g-}^\circ\text{C}) + (0.515 \text{ g/cm}^3 \times 1.63 \text{ cm}^3 \times 2.88 \text{ J/g-}^\circ\text{C})) \times 75^\circ\text{C} / 1,253 \text{ W} = 0.31 \text{ sec}$$

For the calendaring process, the layers will be moving together, so the worst case heating time of 0.41 seconds is used to determine the required oven length. At a substrate speed of 5 m/min (8.33 cm/sec), the required oven length of about 0.34 meters. Using two heaters (one for each layer) at a heater watt density of 23 kW/m<sup>2</sup> (0.0023 kW/cm<sup>2</sup>) and energy cost of \$0.07/kW-hr, the heater energy rate is:

$$10 \text{ kW: Heater energy rate} = 2 \times 23.4 \text{ cm} \times 3.4 \text{ cm} \times 0.0023 \text{ kW/cm}^2 \times \$0.07/\text{kW-hr} = \$0.0256/\text{hr}$$

$$25 \text{ kW: Heater energy rate} = 2 \times 30.4 \text{ cm} \times 3.4 \text{ cm} \times 0.0023 \text{ kW/cm}^2 \times \$0.07/\text{kW-hr} = \$0.0333/\text{hr}$$



At 5 m/min (30,000 cm/hour) part throughput is:

10 kW: Parts per hour = 30,000 cm/hour / 17.5 cm = 1714 parts/hour

25 kW: Parts per hour = 30,000 cm/hour / 22.4 cm = 1339 parts/hour

The heater energy cost per part is:

10 kW: Heater energy cost = \$0.0256/hour / 1714 parts/hour < \$0.01/part

25 kW: Heater energy cost = \$0.0333/hour / 1339 parts/hour < \$0.01/part

Once the material layers are preheated, they are compressed between steel rollers that bond the catalyst decal layer to the membrane. The decal substrate is then peeled away from the decal layer and collected on a roll or in a bin. The primary cost for the calendaring rollers is the motor used to drive them. The QSY XY-21/620 calendaring machine with 580 mm working width and 250 mm roll diameters capable of 15 m/min throughput is powered by a 15 kW motor. Heated rollers generally consume 1.5 kW per roller, making the energy cost to run this equipment at 5 m/min (30,000 cm/hour) is:

10 kW: Calendar roller energy cost = \$0.07/kW-hr × 18 kW / 1714 parts/hour < \$0.01/part

25 kW: Calendar roller energy cost = \$0.07/kW-hr × 18 kW / 1339 parts/hour < \$0.01/part

The energy cost of the calendaring operation is negligible compared to the assumed standard machine rate of:

10 kW: Calendar machine cost = \$25/hr / 1714 parts/hour = \$0.015/part

25 kW: Calendar roller energy cost = \$25/hr / 1339 parts/hour = \$0.019/part

## A.6 Cost Comparison to DTI 2010

### Stack Equivalence

In their report “Mass Production Cost Estimation for Direct H<sub>2</sub> PEM Fuel Cell System for Automotive Applications: 2010 Update”, DTI assumed that the PEMFC stack had the following key characteristics:

|                                     |        |                    |
|-------------------------------------|--------|--------------------|
| Active cells per stack              | 369    | cells              |
| Cell voltage at max power           | 0.676  | V/cell             |
| Membrane power density at max power | 0.833  | W/cm <sup>2</sup>  |
| Active area per cell                | 285.84 | cm <sup>2</sup>    |
| Total area per cell                 | 357.3  | cm <sup>2</sup>    |
| Ratio of active area to total area  | 0.80   |                    |
| Catalyst loading                    | 0.15   | mg/cm <sup>2</sup> |
| Gross power per stack               | 87.91  | kW                 |
| Net power per stack                 | 80     | kW                 |

In our report “Manufacturing Cos Analysis of 10 kW and 25 kW Direct Hydrogen Polymer Electrolyte Membrane (PEM) Fuel Cell for Forklift Applications”, Battelle assume that the PEM stack had the following key characteristics:

|                                     |       |                    |
|-------------------------------------|-------|--------------------|
| Active cells per stack              | 66    | cells              |
| Cell voltage at max power           | 0.65  | V/cell             |
| Membrane power density at max power | 0.65  | W/cm <sup>2</sup>  |
| Active area per cell                | 200   | cm <sup>2</sup>    |
| Total area per cell                 | 409.5 | cm <sup>2</sup>    |
| Ratio of active area to total area  | 0.49  |                    |
| Catalyst loading                    | 0.6   | mg/cm <sup>2</sup> |
| Gross power per stack               | 11    | kW                 |
| Net power per stack                 | 10    | kW                 |

To create a Battelle MHE stack with equivalent performance of the DTI automotive stack, we start by back calculating the required active area for the Battelle MHE stack based on the DTI power density:

$$11000 \text{ W} / 0.833 \text{ W/cm}^2 = 13,205 \text{ cm}^2 \text{ active area}$$

Assuming 200 cm<sup>2</sup> active area per cell for MHE systems in accordance with feedback from Ballard and Hydrogenics, the number of active cells for the Battelle MHE stack is:

$$13,205 \text{ cm}^2 / 200 \text{ cm}^2/\text{cell} = 66 \text{ cells}$$

Using DTI's assumption of the ratio of active cell area to total cell area, the overall cell size for the Battelle MHE stack becomes:

$$200 \text{ cm}^2/\text{cell} / 0.80 = 250 \text{ cm}^2$$

DTI also assumes a cell aspect ratio of 1.5:1, giving final overall dimensions for the Battelle MHE cells of

Active area: 115 mm x 173 mm

Total area: 129 mm x 194 mm

Therefore, a Battelle MHE stack comparable to the DTI automotive stack would have the following characteristics:

|                                     |       |                   |
|-------------------------------------|-------|-------------------|
| Active cells per stack              | 66    | cells             |
| Cell voltage at max power           | 0.676 | V/cell            |
| Membrane power density at max power | 0.833 | W/cm <sup>2</sup> |
| Active area per cell                | 200   | cm <sup>2</sup>   |
| Total area per cell                 | 250   | cm <sup>2</sup>   |
| Ratio of active area to total area  | 0.8   |                   |
| Gross power per stack               | 11    | kW                |
| Net power per stack                 | 10    | kW                |

The lowest automotive manufacturing volume in the DTI report is 1,000 systems, which requires the manufacture of 369,000 cells. This is equivalent to Battelle MHE system annual production volumes of:

$$(369 / 66) \times 1,000 = 5,591 \text{ systems}$$

Therefore, the material costs assumed by DTI for the production of 1,000 automotive systems can be assumed to apply for the production of 5,591 Battelle MHE systems.

### Part Costs

The material costs requiring adjustment in the Battelle MHE stack manufacturing cost models for comparison purposes are as follows:

| Material         | Cost     |                    | DTI 2010 Report Ref. |
|------------------|----------|--------------------|----------------------|
| Platinum         | \$1,100  | /tr.oz.            | Section 4.4.4        |
| Platinum loading | 0.15     | mg/cm <sup>2</sup> | Fig. 2               |
| Nafion           | \$2,000  | /kg                | Fig. 42              |
| Membrane         | \$224.45 | /m <sup>2</sup>    | Fig. 44              |
| GDL              | \$71.83  | /m <sup>2</sup>    | Fig. 58              |

Using the above cost input parameters and updated overall cell dimensions in the MHE stack DFMA<sup>®</sup> models, the part costs are:

|                          |         |       |
|--------------------------|---------|-------|
| Catalyzed membrane       | \$8.25  | /part |
| MEA hot press            | \$4.09  | /part |
| Composite bi-polar plate | \$3.81  | /part |
| Silicone gasket          | \$1.12  | /part |
| End plate                | \$22.35 | /part |
| Tie rods & nuts          | \$5.00  | /part |

#### Final Stack Cost

Entering the revised part cost into the DFMA<sup>®</sup> MHE stack assembly models, total stack cost was computed as:

|                                |            |        |
|--------------------------------|------------|--------|
| Part cost                      | \$1,485.72 | /stack |
| Assembly cost                  | \$28.17    | /stack |
| Stack testing and conditioning | \$221.18   | /stack |

Adjusting the assembly labor cost for learning curve effects (see Battelle draft report, Appendix A.7) using an annual volume of 5,591 systems, the final stack costs are computed as:

|                                |            |                      |
|--------------------------------|------------|----------------------|
| Part cost                      | \$1,485.72 | /stack               |
| Assembly cost                  | \$28.32    | /stack               |
| Stack testing and conditioning | \$221.18   | /stack               |
| Total cost                     | \$1,735.22 | /stack               |
| Total cost                     | \$157.74   | /kW <sub>gross</sub> |
| Total cost                     | \$173.52   | /kW <sub>net</sub>   |

Comparing the above costs with those estimated from Figs. 160 and 161 of the DTI report:

|                                    | Battelle<br>MHE | DTI<br>Automotive |
|------------------------------------|-----------------|-------------------|
| Stack cost per kW <sub>gross</sub> | \$158           | \$145             |
| Stack cost per kW <sub>net</sub>   | \$174           | \$159             |

#### Conclusion

After compensating for differences in assumed stack performance parameters, the Battelle MHE stack cost estimates are within 10% of the DTI automotive stack cost estimates on both a per kW<sub>gross</sub> and per kW<sub>net</sub> basis.

## A.7 Assembly Cost Learning Curve Calculations

The DFMA<sup>®</sup> software produces an assembly cost based on hand assembly at its most efficient, which is \$50.32 for the 10 kW stack, \$52.47 for the 25 kW stack, and \$44.94 for the rest of the system. The learning curve analysis essentially backs that number up to a time when bugs are still being worked out of the assembly process.

From Cost Estimator's Reference Manual, Stewart, R.M., et al, 2<sup>nd</sup> Ed., Wiley-Interscience, 1995, the general equation is:

$$Y = AX^b$$

where:

- Y = time or cost per cycle or unit
- A = time or cost for first cycle or unit
- X = number of cycles or units
- b = log(m)/log(2)
- m = slope of learning curve

For stack assembly cost, if we assume that m = 0.85 (typical for aerospace processes), then:

$$b = \log(0.85)/\log(2) = -0.23447$$

If the stack assembly process is “learned” after 100 units, and the cost of the X = 100<sup>th</sup> stack is the BDI DFMA<sup>®</sup> cost, then the cost of the first unit is:

$$\begin{aligned} 10 \text{ kW: } A &= Y / X^b = 50.32 / 100^{(-0.23447)} = \$148.14 \\ 25 \text{ kW: } A &= Y / X^b = 52.47 / 100^{(-0.23447)} = \$154.47 \\ \text{System: } A &= Y / X^b = 44.94 / 100^{(-0.23447)} = \$132.30 \end{aligned}$$

The average cost to assemble the first 100 units ( $\bar{C}_{100}$ ) is calculated as:

$$\begin{aligned} 10 \text{ kW: } \bar{C}_{100} &= \frac{\left( \sum_{i=1}^{100} 148.14 * i^{(-0.23447)} \right)}{100} = \$64.82 \\ 25 \text{ kW: } \bar{C}_{100} &= \frac{\left( \sum_{i=1}^{100} 154.47 * i^{(-0.23447)} \right)}{100} = \$67.59 \\ \text{System: } \bar{C}_{100} &= \frac{\left( \sum_{i=1}^{100} 132.30 * i^{(-0.23447)} \right)}{100} = \$57.89 \end{aligned}$$

The cost to assemble all subsequent units is assumed to be A, making the average cost to assemble n units (n > 100) is calculated as:

$$\bar{C}_n = \frac{\left( \left( \sum_{i=1}^{100} A * i^{(-0.23447)} \right) + (A * (n - 100)) \right)}{n}$$

Using the above equations, the average stack assembly costs are:

| 1 <sup>st</sup> Year Average Assembly Cost per Stack |                 |       |        |
|--|-----------------|-------|--------|
|  | Stacks per year |       |        |
|  | 100             | 1,000 | 10,000 |
| 10 kW Stack  | 64.82           | 51.77 | 50.46  |
| 25 kW Stack  | 67.59           | 53.98 | 52.62  |
| System   | 57.89           | 46.23 | 45.07  |