



# Virginia Tech

## Wind Turbine Team

**2018 U.S. Department of Energy Collegiate Wind Competition**

**Virginia Polytechnic Institute and State University**

**Kevin T. Crofton Department of Aerospace and Ocean Engineering**

Blacksburg, Virginia, (540) 231-6611, [WindTurbineTeamVT@vt.edu](mailto:WindTurbineTeamVT@vt.edu)

[www.vtwtteam.aoe.vt.edu](http://www.vtwtteam.aoe.vt.edu), Twitter/Instagram/Facebook: @WindTurbineTeamVT

### Team Leaders

**Albrey de Clerck** (Team Student Leader) & **Matthew Dudon** (Project Manager)

**Rishi Nittala** (Business), **Ethan LeBoeuf** (Blade), **Colton Miller** (Drive/Tower),

**Jacquelyn Noel** (Communications), **Spencer Paul** (Power Electronics), **Adam Wise** (Siting)

### Advisors

**Dr. Matthew Kuester** (Principal Investigator, Department of Aerospace Engineering)

**Dr. Arthur Ball** (Assistant Investigator, Department of Electrical Engineering)

**Erik Wike** (Assistant Investigator, Department of Mechanical Engineering)

*Members: 34 (12 different majors), Advisors: 3, Volunteers: 10*



Kevin T. Crofton Department of Aerospace and Ocean Engineering



## Executive Summary

Ut Prosim Power (UPP) is a for-profit organization that sells 50 kW wind turbines to small-scale data centers to offset electricity costs and provide an extra level of power redundancy - all while providing clean, renewable electricity. Ut Prosim stands for “That I May Serve,” and UPP prides itself in serving the need to secure individual’s and company’s data while doing so in a clean energy manner. UPP will commence its operations in late 2018. The company is responsible for the design, installation, and maintenance of 50 kilowatt turbines that it intends to sell to its customers. UPP holds value to its customers as its most important responsibility. UPP will enter the market in the state of Connecticut as the average cost per kilowatt-hour is approximately \$0.1699, much higher than most other states. The average power requirement of UPP’s target market is approximately 100 kilowatts resulting in an electricity cost of approximately \$148,000 for each data center. The addition of four 50 kilowatt turbines, with a capacity factor of 30%, results in a 60 kilowatt power supplement to each data center. Hence, UPP will sell in packages of four 50 kilowatt turbines.

UPP will maintain a zero inventory strategy and outsource all manufacturing, transportation, installation, and maintenance to third parties as this strategy enables UPP to be asset light and to keep costs low. UPP will process all orders in a Make-To-Order supply strategy to mitigate any inventory risks. UPP is seeking an investment of \$800,000 in exchange for 37.5% equity in the company. The Chief Financial Officer of UPP has projected a five-year valuation of \$3.8 million resulting in a 181% of a Return on Investment for its investors in the event of the sale of UPP.

UPP has taken several steps to ensure the success of this business strategy. UPP’s 50 kW turbine is designed for efficient operations at a low cost point. The design features a three blade, horizontal axis, upwind turbine with active pitch control, a direct-drive shaft, and a permanent magnet generator. To ensure the market turbine will perform as designed, a scaled test turbine with a similar system layout to the market turbine was designed, built and tested. From the testing results of this prototype turbine, UPP is confident that the market turbine design is sound and will perform as expected.



Figure 1: Ut Prosim Power's market wind turbine (left), logo (middle), and testing wind turbine (right).

# Table of Contents

Executive Summary .....	1
Table of Contents .....	2
Business Plan .....	3
Business Overview.....	3
Market Opportunity.....	3
Go-to-Market Procedure .....	4
Marketing Strategy .....	5
Management Team.....	6
CEO: Chief Executive Officer .....	6
COO: Chief Operating Officer.....	6
CFO: Chief Financial Officer .....	6
CTO: Chief Technology Officer.....	7
Operations Facilitator (1-2).....	7
Development and Operations.....	7
Research and Development.....	7
Impacts.....	7
Operations, Manufacturing, and Risk Mitigation .....	7
Financial Analysis.....	8
Phase I.....	8
Phase II .....	9
Phase III.....	9
Exit Strategy .....	10
Operating Agreement.....	12
Future Technological Development.....	12
Technical Design .....	13
Design Objective.....	13
Market Turbine .....	13
Test Turbine .....	14
Blade/Hub Design.....	15
Static Performance Analysis .....	17
Drive/Tower Design .....	18
Electrical Design.....	22
Test Turbine: Control Design .....	26
Testing Results.....	27
References.....	29

# Business Plan

## Business Overview

The leadership team of UPP (logo shown in Figure 2) has developed a vision to provide affordable renewable energy to data centers across the United States, curbing the expenditure on electricity and helping companies secure their information. The company's vision is materialized by providing UPP's customers with 50 kW turbines with mid- to long-term repayment plans. The 50 kW turbine (three blade, horizontal axis, upwind turbine with active pitch control, a direct-drive shaft, and a permanent magnet generator) is fully described in the Market Turbine section. UPP's entire business operations is set up to minimize the cost of the wind turbine, and this cost savings is passed along to the customer. Looking forward, UPP will address future uncertainty in the market by researching/developing future expansion strategies (such as geothermal cooling systems as an additional green energy source), but with the option to utilize an exit strategy after five years.

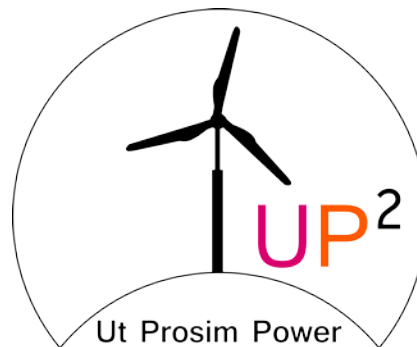

Figure 2: Ut Prosim Power Logo

## Market Opportunity

Data centers are buildings that house various computing components and centralizes the information technology of an organization. Data centers are increasingly critical to the daily operation for many companies, and often stores some of the organization's most critical information. As result, continued operation and reliability of data centers is becoming a pressing issue nationwide [11].

Data centers typically draw power from the grid while ensuring they have a redundancy in power. This redundancy is achieved via the existence of secondary sources of power such as an Uninterrupted Power System (UPS), which acts as a system of batteries, and a power generator that is typically run on diesel. The UPS is activated is a matter of milliseconds in the event of a power outage from the grid. That being said, a typical UPS can only power the data center for a very short amount of time before the power generator is activated.

While efforts are being made to reduce data center power consumption, in 2014 data centers consumed 70 billion kWh, approximately 1.8% of the nation's energy usage [7]. With such a large energy consumption, it is important to look at the distribution of data centers and look at their sizing. There are approximately 3 million data centers nationwide [7], with that number incorporating hyperscale data centers to a small scale 1 rack data center. A single rack consists of at most 40 servers, with each server requiring 0.492 kW of electricity [3].

In its market plan, UPP is targeting clients where it is realistic to achieve over 50% energy generation for the client, with four turbines or less to be realistic about land usage and availability. The 50% energy generation goal is to meet the tax incentives threshold and generate more savings, creating a more

enticing business model for the client. Given that UPP's market turbine is rated at 50 kW, the target market is data centers that consist of five racks or less. A five rack data center has at most a power consumption of 98.4 kW, where assuming a capacity factor of 30% for UPP's turbines, four turbines would supply 60 kW, meeting the tax incentives threshold.

A five rack data center can be classified as a small data center. Small data centers have approximately 33% representation in rural areas, with 66% representation in urban settings. There are approximately 20,000 one rack data centers and 13,000 two to five rack data centers in the continental United States. Excluding one rack data centers, which can largely be supported by one of UPP's wind turbines, our target market of under five rack data centers has approximately 4300 data centers in rural settings [4]. The reason that rural settings are desirable is largely due to the fact that land is cheaper, while zoning regulations are looser.

Aside from energy production, data centers are interested in renewable energy for its independence from the grid. In the event of shutdown, the mean cost per shutdown for a small data center is \$99. Data centers are already typically equipped with a UPS system and backup generator to supply electricity in the event of grid shutdown. Wind energy being independent of the grid means that in the event of shutdown, electricity is still supplied to the data center system. This electricity can be used to prolong a UPS or generator system, reducing the likelihood of a data center shutdown and providing an islanded mode for the wind turbine power. The unreliability of wind is not a significant factor here, as capacity factor properly accounts for this and the data center has a guaranteed energy source in the generator for extreme conditions where no wind power is generated. The desire for energy redundancy in data centers creates a hidden benefit in marketing wind turbines to this market. After the event of a shutdown, 50% of businesses never recover, while 90% of small data centers go out of business within two years [1]. These staggering numbers encourage data centers to be proactive in regards to energy supply, as a single outage can be disastrous for the business.

## Go-to-Market Procedure

The go-to-market strategy is heavily dependent on where UPP should first sell their turbines. UPP has decided to begin to expand its operations in the state of Connecticut. The reasoning for this decision will be explained in this section. The determination the location depended on three main factors. The first factor was the cost of electricity for commercial entities in each state in the United States of America. UPP will only be focusing their operations in the contiguous United States, hence, this excludes Hawaii and Alaska. The second factor is the wind speed in the particular locale of the data centers. Finally, the third factor in considering the location of the first few customers is the zoning laws and regulations in the area. Various zoning laws and regulations pose multiple risks to UPP's turbine deployment and ultimately the business model.

## Cost of Commercial Electricity

The cost per kilowatt-hour varies drastically by state. The average five-rack data center uses approximately 100 kW of power, assuming that each rack holds up to 40 servers. This means that they would consume 100 kWh of energy in an hour, which ultimately implies that a typical five-rack data center consumes approximately 876,000 kWh per year. An example of a state in which commercial entities do not incur high costs per kWh consumed is Texas. In the event a five-rack data center in Texas consumes 876,000 kWh per year, the data center should incur a total electricity cost approximating to \$71,656.80 [9]. Installing four turbines each worth \$350,000 may not be a very strong value proposition to a data center in a state such as this with low electricity costs. UPP aims to provide the most amount of value possible to each customer. Therefore, choosing a state that has a moderate wind potential but exorbitant electricity costs is essential to providing value for customers.

The average cost of electricity per kilowatt-hour for the state of Connecticut's commercial entities is \$0.1699 [9] as opposed to Texas' \$0.081. A five-rack data center's annual electricity costs in Connecticut

should approximate to \$148,832.40, which is over twice as much as it would have cost in Texas. Installing multiple turbines in this data center will provide more value than it would have in Texas or any other low cost states. UPP will, over time, expand its operations through the New England and Middle Atlantic regions of the United States. The average costs per kilowatt-hour of electricity in the aforementioned regions of the United States range from \$0.0916 to \$0.1699, with Pennsylvania and Connecticut being the lowest and highest in the range respectively.

### Wind Speeds

The wind speed in a particular region has a very high correlation with the capacity factor of the wind turbines. The capacity factor can be defined as the average power generated divided by the rated maximum power [10]. The definition implies that a turbine with a rated power of 50 kW may, on average, generate 10 kW of power in a region that has an average capacity factor of 20%. It is imperative to note that a 20% capacity factor does not necessarily mean that the total power generated by a 50 kW turbine will be restricted to 10 kW at any given time. The capacity factor takes into account of the changes of wind speed over time; it includes the entire duration of time that the turbine is installed, not just the time and period it was in full working order and actively generating power. Many parts of Connecticut have wind speeds that enable capacity factors between 30% to 34% (8), which implies that with a 50 kW turbine, the average power generation could be between 15 kW to 17 kW.

### Regulations

Installing wind turbines are constrained by many zoning laws and regulations. Small wind turbines that do not have vertical blades cannot easily be installed in urban settings. Therefore, UPP will be targeting data centers that are located in rural settings. This gives the turbines the adequate space required without incurring any regulatory constraints. One risk for UPP, however, is if a data center is situated amongst many buildings, instead of a standalone building, then the complexity of the installation of the turbine would increase. The turbines would have to be installed at a certain distance away from buildings to prevent incurring any zoning constraints. Small scale data centers in the New England and Middle Atlantic regions tend to be located in relatively rural settings. Therefore, UPP will cater to the data centers that are located in standalone buildings with adequate space for the turbines to be installed.

### Marketing Strategy

UPP's marketing strategy is composed of three different avenues. The first being the development of an online presence. The low cost of implementation makes it a great way to begin marketing our product since revenues will not have been raised at this point. This avenue not only includes a website just for our product, but also incorporates the use of social media. The importance of a strong social media presence is often overlooked by older businesses, however, its importance is increasingly becoming more apparent. Accounts will be created across different platforms such as LinkedIn, Twitter, and Facebook just to name a few. This broader exposure will maximize our brands recognition in the early steps of the company's development. The next avenue that we will look at is attending conferences. There are hundreds of data center conferences that happen annually that will be key in acquiring new clients. Although there are some expenses to this, such as the cost of transportation and hospitality estimated around \$4,000/conference, this is marginal compared to the opportunity that is available at these conferences. Important information about each of the data centers, such as amount of racks and power usage, can be collected and centers that fall within our criteria can be directly contacted and pitched to. This approach will save our employees hours of researching time by having possible target clients collectively in a central location. UPP will attend one conference every 3 months for a total of 4 per year. The last avenue that we have included into our marketing strategy is affiliate marketing. We believe that by joining with a company in a parallel industry we can promote one another's products to broaden our scope of consumers. For example, by teaming up with a

cable company that manufactures cables that are necessary for the turbines, we can find more consumers in this market. There will also be constant efforts to reach out to other promotional avenues such as newspapers and magazines to continually grow the companies stand in the wind turbine industry.

To ensure that the market opportunity was applicable and acceptable, the leadership team conducted surveys, talk to entrepreneurs, and visited data centers with the proposed business model. The leadership team visited the Biocomplexity Institute's Data Center at Virginia Tech to validate the idea of providing green energy through wind turbines to offset the overall cost of electricity. They responded with a substantial amount of enthusiasm, albeit with a few hesitations on the size of the turbines. That being said, it is understood that the turbines that UPP will sell is not meant for a large scale data center like the one the leadership team had visited. All in all, the engineers and management at the Biocomplexity Institute at Virginia Tech responded positively when the leadership team disclosed the payment plan for the set of wind turbines that UPP will sell to smaller scaled data centers.

## Management Team

The management team at UPP is crucial to the overall success of the company and serving its customers with protecting their data while providing clean energy in doing so. Four individuals with encompass the team with their expertise in both the company's vision and skills needed to deploy the business strategy in a changing marketplace.

### CEO: Chief Executive Officer

The Chief Executive Officer of UPP is Matt Dudon. Matt is an engineer and entrepreneur who understands the potential and the ins and outs of wind energy and the advantages of its application to data centers. Having led UPP from the beginning of the design process to a final product, nobody understands the product better, nor has anyone put more time and effort into this company. Matt's ability to look at the big picture and manage many moving parts has been exemplified time and again, and his communication and leadership skills are unparalleled. He is undoubtedly qualified to fulfill the roles of CEO and CMO, and excel in them. Matt will constantly communicate with members in the company as well as investors to discuss business plans moving forward, and carry the company towards success.

### COO: Chief Operating Officer

Albrey de Clerck will serve as the Chief Operating Officer, overseeing all of the operations of the company. Like Matt, Albrey has helped lead UPP from the very beginning and has exhibited his leadership, communication, organizational, technical, and management skills time and time again. Albrey played a huge role in the planning and design process of the wind turbine and is now an expert on his product which will enable him to perform exceptionally in this role. Albrey will be in constant communication with customers, potential customers distributors, and all other heads of parts of the daily operations. His skillset is tailored to that of an extremely capable COO and one bound to help bring success to UPP.

### CFO: Chief Financial Officer

As Chief Financial Officer, Adham Nabhan will be responsible for managing all financial aspects of the organization. Adham's tenure at GE Renewable Energy has provided him with a unique perspective into the field of wind energy and will be the foundation for which he directs the financial affairs of UPP. The importance of sound financial execution for an operation of UPP's magnitude cannot be understated; the company is confident in Adham's abilities given his critical decision making, organizational skills, and fiscal responsibility. His technical background is also attractive for this position, as Adham understands the

budgetary obligations that various components of the organization demand. He has developed a close professional relationship with the other executives of UPP, which will serve the company well in the future.

### CTO: Chief Technology Officer

Adam Wise will be the Chief Technology Officer of UPP. As CTO, he will be in charge of the company's strategic technical direction. Adam's strong practical background gives him the expertise to lead the engineering department and his experience in the field of wind energy has proven to be an asset during the design process of the wind turbine. Throughout this process, Adam has been able to identify the market needs and adapt the long-term technical goals of the company. Adam's proven leadership of interdisciplinary engineers makes him a great fit for CTO of UPP.

### Operations Facilitator (1-2)

As business expands while UPP hopes to increase our number of clients, it may be necessary to employ additional hands to help with day-to-day operations in order to continue increasing clientele and maintaining necessary communication with current clients. Atul Kumar and Varun Kumar are already well known affiliates of UPP who have both exemplified exceptional technical understanding of the product, as well as ability to recognize business opportunities. Adding these employees will be the final step in expanding the organizational structure of the company and they will be just what UPP needs to bring in more revenue.

## Development and Operations

### Research and Development

The UPP team has built a 30 W prototype turbine, developed at Virginia Tech for the Collegiate Wind Competition. The turbine will be designed, tested with software, and deployed in both a wind tunnel at Virginia Tech and in Chicago at the Collegiate Wind Competition. After multiple rounds of testing, the design will be iterated until the whole system is confirmed, paralleling the design directly to the 50 kW market wind turbine. This allows UPP to spend minimal capital on research development while still proving concepts and the final design.

### Impacts

UPP values effective and efficient products that can serve our customers in a clean and green manner. Not only must our wind turbines be efficient but the life cycle of the product must be green in every aspect. Therefore, discussed in the coming section, our vendors are chosen with high standards, and we request that certain composites and processes be recycled according to our standards. This ensures our product is not only producing clean energy but was manufactured in a green manner, having minimal impacts on the environment. Socially, the UPP will only conduct business with ethical business partners and those that support green technology. This will give UPP and our vendor's opportunities to partner and promote green technology while benefiting in an investment partnership.

### Operations, Manufacturing, and Risk Mitigation

UPP is dedicated to having lean operations, ensuring low cost for the customer. We will maintain this lean infrastructure by eliminating distributors. We will order all our needed parts with a just in time strategy from our vendors and have them transported directly to the customers' locations. Our



manufacturers will be chosen with specific characteristics: lean production strategies, use of recycled materials and processes, and energy efficient facilities. This ensures that each part of our operation is not only financial sound but also clean and efficient for the environment. Yet, because we are buying our parts from a vendor, there is a large risk of them not producing exactly the part that is needed for our wind turbine. To mitigate this deviation and risk, most of our custom parts will be build-to-print, allowing us to keep control over intellectual property and the finished product delivered to our customer. One other risk of delivering straight from the vendor to the customer is potential faulty parts, the need to order new parts, and unexpected lead times until the product can be fully assembled. Therefore, to ensure this does not occur and is caught before shipment, we will provide thorough inspections procedures for our vendors before they ship out any parts. If the parts deviate from the required inspections and specifications, they will have to contact the Chief Technology Officer to make the final decision. If the vendor does not abide by this agreement and protocol, they will be subject to losing our business as discussed with our Chief Executive Officer.

Once the parts get to the customers' location, the turbine will be assembled there to reduce the amount of transportation of the large materials. The lead time from placing an order to shipping the parts to the customers' locations is approximately 45 days along with an installation time of 7 days. However, to account for possible delays we market the lead time as 60 days for the customer. This length of time will also make it easier for clients to pay for the turbines by fragmenting the payment into a down payment as well as installed payments over nine months. The first payment will be given from the clients as an initial deposit and the following installed payments will be after the turbine is fully installed and functioning. This system also allows us to reduce the initial capital that will need to be borrowed since the initially deposited money will directly go to our costs of materials. This approach will eliminate holding costs through removing the need of a warehouse to hold the materials before assembly. This innovative strategy of operations will maximize profits through the reduction of unnecessary inventory costs.

## Financial Analysis

UPP's financial plan is separated into three phases, however, the phases all follow a general structure. The general structure is set so that the client pays for half of the selling price, which is \$350,000 per turbine. This initial capital raised will only cover 68% of our installed costs of \$270,000. The installed cost was determined by the bill of material shown in Table 1. The market turbine will be discussed further in a following section of this report.

The remaining 32% will be sourced by our company. Once the turbine is fully installed the client will be expected to pay for the remainder of the selling price with fixed costs over a 9 month period. This extension of cost allows customers to gain savings revenue from the installed turbine to help subsidize the fixed payments, 50% of the selling price divided over 9 months. This structure is generally kept throughout the implementation process, however, it may vary depending on phase.

### Phase I

Phase one is the initial acquisition of our first client. The market we are targeting will require around four turbines per customer. The customers in phase one, which lasts for a period of 1 year and 3 months, will be acquired in a staggered manner with a 10 month idle period between them. For the first client we will source the remainder 32% of manufacturing costs, around \$95,000 per turbine, as well as \$20,000 extra in buffer capital. Each client is expected to require 4 turbines so the total amount collected from investors will be \$800 k for a 37.5% equity in our company. By the 10th month we will have raised enough capital from the first client's fixed payments to cover the 23% manufacturing costs for client 2 and not therefore not require investor support after this initial investment. To also aid in creating self-sufficiency, the leadership team will be provided minimal compensation for the first year. After subtracting costs such as

conference, marketing, payroll, and income tax, the first year net earnings from UPP’s first two customers is projected to be \$76,809.92.

Table 1: Market Turbine Bill of Materials

Category	Item	Percentage of Installed Cost	Price
Wind Turbine	Tower	23.16%	\$62,381.40
Wind Turbine	Rotor Blades	19.55%	\$52,656.55
Wind Turbine	Rotor Hub	1.21%	\$3,249.53
Wind Turbine	Rotor Bearings	1.07%	\$2,893.74
Wind Turbine	Main Shaft	1.68%	\$4,530.36
Wind Turbine	Main Frame	2.47%	\$6,641.37
Wind Turbine	Generator	3.03%	\$8,159.39
Wind Turbine	Yaw System	1.10%	\$2,964.90
Wind Turbine	Pitch System	2.34%	\$6,309.30
Wind Turbine	Transformer	3.16%	\$8,515.18
Wind Turbine	Brake System	1.16%	\$3,130.93
Wind Turbine	Nacelle Housing	1.19%	\$3,202.09
Wind Turbine	Cables	0.85%	\$2,277.04
Wind Turbine	Screws	0.92%	\$2,466.79
Wind Turbine	Foundation	10.97%	\$29,550.00
Zoning	ZPII	5.09%	\$13,700.00
Transportation	Logistics	2.41%	\$6,500.00
Infrastructure	Electrical Infrastructure	8.50%	\$22,900.00
Installation	Installation	9.71%	\$26,150.00
Taxes	Taxes	0.45%	\$1,200.00
<b>Total</b>	-	<b>100.00%</b>	<b>\$269,378.57</b>

## Phase II

Phase two begins on the 7th fixed payment of client 2 in order to save enough profit to take on client 3, which will occur in the same month as the 7th payment. During phase two we will continue to stagger the client acquisition in a way that keeps profits positive while also incurring a \$7,000 cost for employee compensation. We found that using this method, we will be able to acquire 3 clients by the end of the 2nd year.

## Phase III

Phase three will be the final phase. The optimal rate of customers we should sell to in this phase is six per year. This will allow UPP to maintain a positive cash flow and obtain a net income to approximately \$1.38 million in the fifth year. This will enable UPP’s valuation to be at \$3,802,443, see Table 2 below for the income statement.

Table 2: UPP’s Income Statement for the first five years

Ut Prosim Power					
Year	2019-2020	2020-2021	2021-2022	2022-2023	2023-2024
Revenue					
Investments	\$779,778	\$0	\$0	\$0	\$0
Revenue Captured	\$2,100,000	\$3,500,000	\$7,544,444	\$7,777,777	\$8,322,221
<b>Total Revenue</b>	<b>\$2,879,778</b>	<b>\$3,500,000</b>	<b>\$7,544,444</b>	<b>\$7,777,777</b>	<b>\$8,322,221</b>
Expenses					
Expenses					
Cost of Turbine	\$1,360,000	\$2,040,000	\$4,080,000	\$4,080,000	\$4,080,000
Cost of Installation (Contracted)	\$800,000	\$1,200,000	\$2,400,000	\$2,400,000	\$2,400,000
Conference and Travel	\$4,000	\$4,000	\$4,000	\$4,000	\$4,000
Magazine Advertisements	\$6,200	\$6,200	\$6,200	\$6,200	\$6,200
Payroll	\$0	\$80,000	\$80,000	\$80,000	\$80,000
Total Operating Expenses					
<b>Total Operating Expenses</b>	<b>\$2,170,200</b>	<b>\$3,330,200</b>	<b>\$6,570,200</b>	<b>\$6,570,200</b>	<b>\$6,570,200</b>
EBITDA	\$709,578	\$169,800	\$974,244	\$1,207,577	\$1,752,021
Income Tax	\$149,011	\$35,658	\$204,591	\$253,591	\$367,924
<b>Net Income</b>	<b>\$560,566</b>	<b>\$134,142</b>	<b>\$769,653</b>	<b>\$953,986</b>	<b>\$1,384,097</b>

In regards to reducing overhead costs, our company will use a “just-in-time” strategy to deliver all materials directly to the client sites and will be constructed there. This will eliminate the cost of holding inventory in warehouses and minimize transportation costs. These savings will be directly reinvested into the company.

Additionally, a balance sheet and a cash flow statement was created for the first five years shown in Table 3 and Table 4 respectively. From Table 3 and 4, it is clear that UPP will have zero liabilities and a positive cash flow.

Using the aforementioned strategies throughout the three phases, UPP has projected the net income for the first five years. Figure 3 shows the behavior and growth of net income throughout the five years on the left and the total cumulative net income through the five for valuation.

## Exit Strategy

In the event of any drastic and rapid changes in the data center industry trends at any given time, UPP will execute its exit strategy at the end of the fifth year. This exit strategy can prevent UPP from possible reductions in revenue due to changes in the trends of the data center industry. Five years will give UPP an ample amount of time to ensure an appealing amount of return on investment for its investors. The fifth year net income is projected to be \$1.384 million and UPP would be valued at \$3.8 M. The initial investor’s equity of 37.5% for their \$800 k investment will yield a return of approximately \$1.41 M which is approximately a 180% return on investment. That being said, UPP will continue to build as much business as possible for the years to come and hence, it will only execute its exit strategy if and only if the industry trends indicate a rapid decline in small scale data centers.

Table 3: UPP's Balance Sheet for the first five years

Ut Prosim Power					
Year	2019-2020	2020-2021	2021-2022	2022-2023	2023-2024
<b>Assets</b>					
<b>Current Assets</b>					
Cash	\$560,566	\$694,708	\$1,464,361	\$2,234,013	\$3,618,110
<b>Total Current Assets</b>	\$560,566	\$694,708	\$1,464,361	\$2,234,013	\$3,618,110
<b>Fixed Assets</b>	\$0	\$0	\$0	\$0	\$0
<b>Total Fixed Assets</b>	\$0	\$0	\$0	\$0	\$0
<b>Total Assets</b>	\$560,566	\$694,708	\$1,464,361	\$2,234,013	\$3,618,110
<b>Liabilities and Equity</b>					
<b>Current and Long Term Liabilities</b>	\$0	\$0	\$0	\$0	\$0
<b>Total Liabilities</b>	\$0	\$0	\$0	\$0	\$0
<b>Owner's Equity</b>					
Stock	\$779,778	\$779,778	\$779,778	\$779,778	\$779,778
Retained Earnings	-\$219,211	-\$85,070	\$684,583	\$1,454,235	\$2,838,332
<b>Total Owner's Equity</b>	\$560,566	\$694,708	\$1,464,361	\$2,234,013	\$3,618,110
<b>Total Liabilities and Owner's Equity</b>	\$560,566	\$694,708	\$1,464,361	\$2,234,013	\$3,618,110

Table 4: UPP's Cash Flow Statement for the first five years

Year	2019-2020	2020-2021	2021-2022	2022-2023	2023-2024
Revenue Captured	\$2,100,000	\$3,500,000	\$7,544,444	\$7,777,777	\$8,322,222
<b>Cash Flows from Operating Activities</b>					
Cost of Installed Turbine	-\$2,160,000	-\$3,240,000	-\$6,480,000	-\$6,480,000	-\$6,480,000
Payroll	\$0	-\$80,000	-\$80,000	-\$80,000	-\$80,000
Conference Accommodation	-\$400	-\$400	-\$400	-\$400	-\$400
Food	-\$1,200	-\$1,200	-\$1,200	-\$1,200	-\$1,200
Travel	-\$2,080	-\$2,080	-\$2,080	-\$2,080	-\$2,080
Conference Fees	-\$320	-\$320	-\$320	-\$320	-\$320
Magazine Advertisements	-\$6,200	-\$6,200	-\$6,200	-\$6,200	-\$6,200
Taxes Paid	-\$149,011	-\$35,658	-\$204,591	-\$253,591	-\$367,924
<b>Net Cash Flows from Operating Activities</b>	-\$2,319,212	-\$3,365,858	-\$6,774,792	-\$6,823,792	-\$6,938,125
<b>Cash Flow From Financing Activities</b>					
Investment earned from investors	\$779,778	\$0	\$0	\$0	\$0
<b>Net Cash Flow From Financing Activities</b>	\$779,778	\$0	\$0	\$0	\$0
<b>Net Cash Flow</b>	\$560,566	\$134,142	\$769,652	\$953,985	\$1,384,097



Figure 3: Growth of net income five years (left) and the total cumulative net income five years for valuation (right).

### Operating Agreement

The operating agreement acts as a protection from irresponsible behavior from the stakeholders involved. An operating agreement is essential for the smooth execution of strategic decisions made by UPP. The operating agreement will clearly outline the voting power of every shareholder in the company. A lawyer is required to draft a comprehensive operating agreement that indicates the voting quorum along with the voting power of each shareholder. The voting quorum will be based on a one-to-one basis to establish minority protection. This agreement will act as a guideline to resolve any disputes that incur among the respective stakeholders. In the event of irreconcilable dispute among the shareholders, the operating agreement will dictate that a majority vote will be used to settle the dispute.

The share equity of UPP will be divided as follows, the investors will be given a 37% stake in the company, while each of the four founders will hold 16% of the share equity. The equal division of shares between the four founders is necessary so as to uphold interest and motivation amongst the founders. The chief divisional officers will be held directly responsible for the activities in their domains of responsibility and each domain has a substantial amount of coordination and precision that is necessary; hence the equal division of share equity amongst the founders is essential.

### Future Technological Development

UPP is constantly searching for ways to not only improve profits but provide technology for our customers to save them money and secure their data. One of the highest energy consumption issues with data centers involve keeping their stacks cool. Cooling servers is not only expensive but can be risky if servers overheat and stop working, losing customer data security. To help prevent this, UPP will conduct research and development in geothermal cooling systems. This design utilizes the properties of heat transfer and the cool geology of Earth's materials. Underneath data centers vertical pipes, containing coolant or water, will wrap through the Earth's ground until properly cooled to return back to the stacks. Geothermal cooling with wind turbines, once developed at UPP, could allow data centers to operate on only renewable energy sources at a fraction of the cost compared with grid electricity rates. UPP will ultimately be providing a high contribution of renewable energy.

# Technical Design

## Design Objective

Three main objectives were considered while designing both the market turbine and the test turbine (Figure 4): simplicity, effectiveness, and cost. Simplicity is important to UPP in order to keep costs of designing, manufacturing, and installing to a minimum. Simplicity also helps important to reduce potential points of failure and thus extra costs. For both the market turbine and the test turbine, simplicity was accomplished by using as many off-the-shelf components as possible as well as by minimizing the number of components needed for the turbines. The second design objective was to produce the most effective and efficient turbines possible. This was accomplished through extensive design processes, analyses, simulations, and testing. Lastly, given that UPP is a for profit company, minimizing was prioritized.

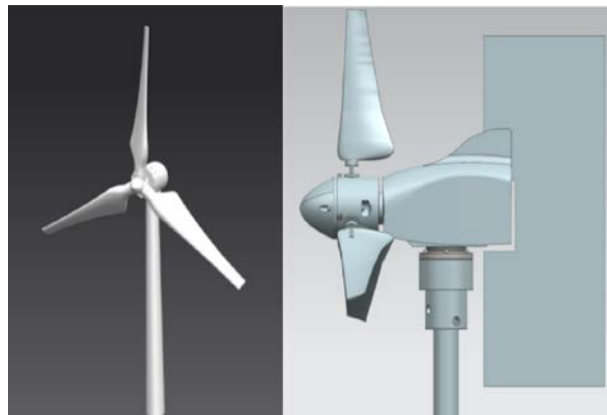

Figure 4: CAD models of the market (left) and testing (right) turbines.

## Market Turbine

The specifications of the market turbine were designed to correlate perfectly with UPP's strategy and plan. The conceptual design features simplicity, effectiveness, and efficiency. The turbine is characterized as a 50 kW, 3-bladed, horizontal axis, upwind, active pitch control, direct-drive wind turbine. The exact specifications are outlined in Table 5. These specifications were chosen and designed to meet the power needs of UPP's customers while abiding by the constraints and standards within UPP's target geographical market. The design class, standard, 50 year peak gust, noise level, and maximum temperature were chosen based on the International Electrotechnical Commission protocol to provide a safe wind turbine to UPP's customers.

UPP's turbine is shown as a CAD model in Figure 5. The rotor diameter, number of blades, rotor speed, cut-in wind speed, and rated wind speed were chosen to produce the needed 50 kW rating with the selected permanent magnet generator (PMG) and blade design. The generator output was chosen specifically for the target market and power distribution of UPP. The design is split into four different sections: (a) hub design, (b) generator/drivetrain design, (c) yaw/tower design, and (d) electronic design. With a simple but effective direct-drive system, the RPM control (a) was chosen to be an active pitch system with motors to drive each individual blade, providing adequate torque with precision for exact blade pitch angles and RPM control of the turbine. The blade design will be optimized using blade element moment theory for ease of manufacturing and peak performance for wind regimes in New England. The braking system along with the selected PMG (b) features a clamping hydraulic brake as a secondary safety feature if active pitch fails to control the turbine's RPM. The yaw and tower system (c) features an active system

with a motor driver and ball bearing to ensure the turbine’s axis is directly into the incoming wind. The 30.6 meter high tower features a tubular, monopole design to abide by UPP’s target market wind characteristics and local regulations. The power inverter (d) is unique because it features a hybrid design that can either be connected to the grid or islanded when the grid is down, providing energy to the customer’s uninterrupted power system. The UPP 50 kW market turbine is the exact product the company needs to meet its strategy, value, and financials.

Table 5: Market Turbine Specifications

<b>Type:</b> Horizontal, upwind, direct-drive	<b>50 Year Peak Gust (m/s):</b> 59.5
<b>Rated Power (kW):</b> 50	<b>Generator PMG Rater Output (V):</b> 360 AC
<b>Design Class:</b> IEC WT Class II	<b>RPM Control:</b> Motor Drive Pitch per Blade
<b>Design Standard:</b> IEC 61400-1	<b>Braking:</b> Clamping Hydraulic Brake
<b>Rotor Diameter (m):</b> 15	<b>Yaw System:</b> Active w/ Ball Bearing
<b>Number of Blades:</b> 3	<b>Tower Tubular (m):</b> 30.6
<b>Design Rotor Speed (rpm):</b> 55	<b>Power Inverter:</b> Hybrid Grid/Island
<b>Cut-in Wind Speed (m/s):</b> 3	<b>Noise Level:</b> 50-55 dB at 30 m from tower
<b>Rated Wind Speed (m/s):</b> 10	<b>Maximum Temperature (C):</b> -20 to 50

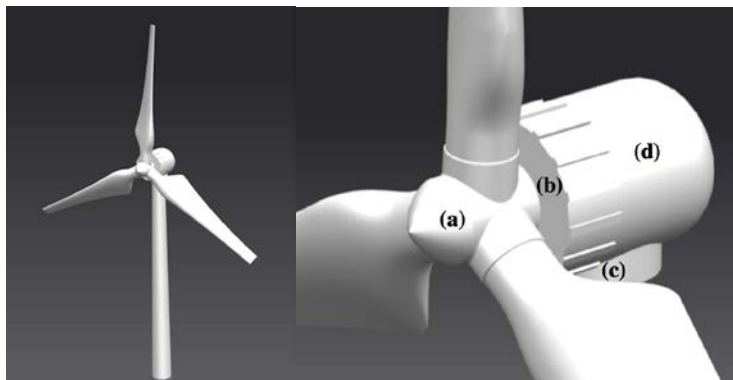

Figure 5: Market turbine conceptual design CAD model (left) and specific components (right).

## Test Turbine

To ensure UPP has a scalable Research and Development wind turbine to test within the competition’s constraints and wind tunnel, a 30 W, 3-blade, horizontal-axis, upwind, active pitch control, direct-drive wind turbine was designed, shown in Figure 4. The test turbine is identical in technical design, only differing in two areas due to restrictions of component and testing sizing. The drivetrain on the test turbine features a single bearing support and driveshaft due to the PMG’s size and inability to put bearings

around the generator for support. The second difference is the passive control system implemented on the testing turbine to limit the power draw needed to drive the motors and the effectiveness of passive yaw at the testing scale. The technical design, described in detail below, is separated into the following sections: blade/hub design, drivetrain/tower design, electronic design, and control design.

## Blade/Hub Design

Identical to the market turbine, the blade/hub design features a 3-blade, horizontal-axis, active pitch control, wind turbine. The blade/hub design is broken up into three sub-designs. The aerodynamics sub-design focuses on the airfoils, chord lengths, and twist values. The mechanical sub-design concentrates on the pitch control system along with the hub and nose cone. The manufacturing and materials sub-design chooses the materials and processes to build each part. These sub-designs work in tandem to ensure confident compatibility with both the hub design and other sub-systems, perfecting the overall design with theory and precise manufacturing techniques.

### Aerodynamics

The aerodynamics sub-design focused on three different areas: airfoil design, chord length, and twist. Initially, the team utilized XFOIL and AirfoilTools data to select airfoils. This airfoil data was input into QBlade and an in-house Blade Element Momentum Theory (BEMT) MATLAB code were used to design the chord and twist distributions.

**Airfoils.** The airfoil design was driven by two performance requirements: maximizing the rated power and reducing the cut-in wind speed. The root of the blade has a greater influence on cut-in wind speed while the tip of the blade has a greater influence on the power performance. Several airfoils were compared, considering their lift to drag (L/D) ratio, lift coefficient, and associated angle(s) of attack. At the root, the FX 63-137 was chosen because of its high lift coefficient to help overcome the generator’s cogging torque. At the tip, the SG6043 was chosen because of its high L/D, which increases power performance. These airfoils are shown in Figure 6 below.

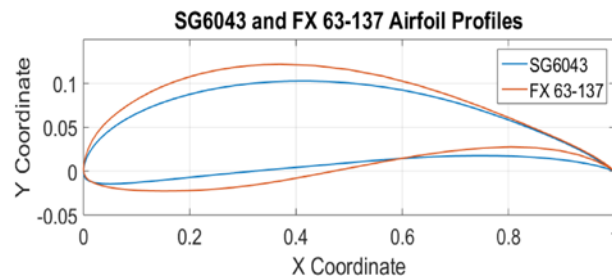

Figure 6: Airfoil profiles used in the blade design.

The FX 63-137 has a maximum lift coefficient of approximately 1.6 at low Reynolds numbers, while having favorable stall characteristics. The lift drop off is fairly flat at 5-7 degrees angles of attack, allowing for better varying twist performance. The SG6043 exhibits a high L/D ratio of approximately 40-60 at low Reynolds numbers. This L/D ratio occurs around 7-9 degrees angle of attack and has steep drop offs on either side. Therefore, in order to get the most efficient performance out of the SG6043, an active pitch control system was designed to pitch the airfoils optimally. This data was confirmed on AirfoilTools.com, giving the team confidence in the airfoil decisions.

**Chord.** The chord distribution, shown in Figure 7, was determined using the BEMT. The chord length has its maximum value at the root and minimum at the tip. The root, having the largest contribution to start-up, has the longest chord lengths. In order to transition smoothly from the hub to the large chord length at the root, a circular cross-section was used for the first portion of the blade. This allows for a less



drastic transition at the start of the blade. The blade is shown Figure 7 below. The team is confident in the chord distribution due to analysis using the BEMT code.

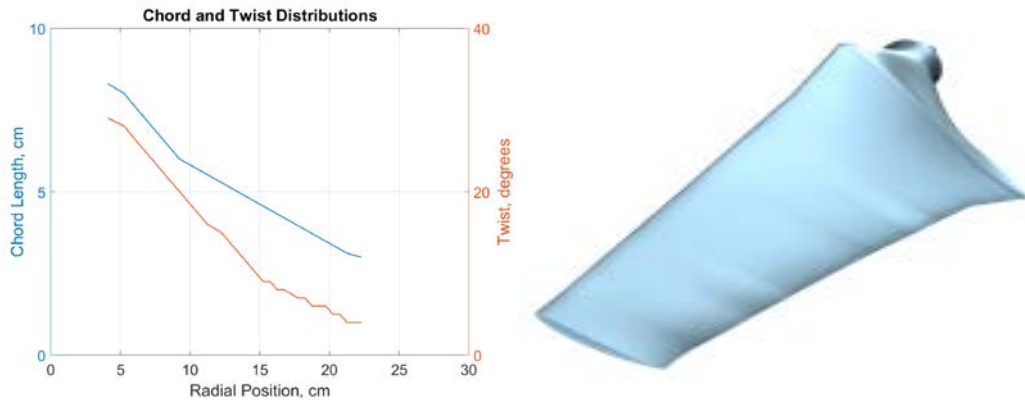

Figure 7: Chord and twist distribution (left), solid model of the final blade design (right).

**Twist.** The twist distribution of the blade was also determined using the BEMT code and is shown in Figure 7. The twist has its maximum value at the root and is much smaller at the tip. The twist is quite important as the aerodynamics is affected by small changes in angle of attack, such as loss of lift and increase in drag after the stall point, drastically decreasing the power output. Pitch control allows for the pitch of the blade to be actively changed uniformly, hence, allowing for flexibility in the aerodynamic design. Results of the BEMT code gave confidence in the twist distribution and overall maximum produced power.

### Pitch Control/Hub

To ensure the testing turbine had identical design to the market turbine and efficient aerodynamic control, an active pitch control system was designed with a hub/nose cone and pitch mechanism.

**Hub/Nose Cone.** Maximizing the effects of an active pitch control system started with the hub and nose cone design. The hub and nose cone assembly, shown in Figure 8, was designed to minimize the hub diameter, influencing aerodynamics, and ensuring an effective pitch control mechanism. The hub diameter was minimized to increase the swept area of the blades; the limiting factor for the hub diameter was the size of the motors for the pitch control system. The length of the nose cone was minimized to maximize the tail system within the 45 cm length allowed by the competition requirements.

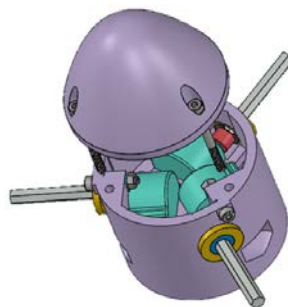

Figure 8: Assembled hub and nose cone with spars.

**Active Pitch Control Mechanism.** The pitch control mechanism was designed identical to the market turbine. Three separate stepper motors, one for each blade, are used to accurately pitch the blades. The steppers were chosen due to their small size and adequate torque. To properly select the motors, the blade's maximum twisting moment at 11 m/s winds was examined to ensure enough torque from the motors

to pitch the blades out of the wind. Determined by the BEMT, the maximum twisting moment was 9.3 mN-m. The chosen stepper motors can produce 34 mN-m of torque, giving a pitching safety factor of 3.65. Additionally, the steppers can pitch the blades in increments of 0.09 degrees, allowing pitching to very specific angles. Overall, the factor of safety for the twisting moment and the small angle increments gave the team confidence in the active pitch control mechanism.

### Manufacturing

To ensure proper materials for each part of the design, the manufacturing processes and material selection was divided into the blades and the hub/nosecone.

**Blades.** The blades were manufactured using negative molds with an expanding foam. This procedure allowed blades to be made quickly (35 minutes/blade) and inexpensively (\$1/blade). To create the physical blades in the molds, an expanding foam was used, which eliminating the need for vacuum bagging. Using CES EduPack, while looking for high strength to density ratios, a polyurethane expanding foam was chosen to create strong but light blades. This foam was used in conjunction with the molds shown in Figure 9 to create the blades also shown in Figure 9. The foam had a high strength to density ratio compared to others, and using the properties given, confirmed the characteristics at rotational speeds of 2500 RPMs and thrust loading at the tip in Finite Element Analysis, shown in Figure 9. 2500 RPMs was much high than the operational RPM of 1400, giving a minimum safety of factor of 4.6. Overall, the blades were manufactured with airfoil shape precision, lost costs, low manufacturing time, and a high factor of safety, giving the team ultimate confidence in the method.



Figure 9: Negative molds for the blades (left), foam blade made from molds (middle), finite element analysis for blade design using selected foam at 2500 RPM.

**Hub/Nose Cone.** The hub and nose cone were manufactured using a resin printer with a tough resin material. This allowed for the hub and nose cone to be manufactured quickly and cheaply, providing strong and precise material.

### Static Performance Analysis

A static blade pitch analysis, shown in Figure 10, was performed on the blade design using QBlade at a pitch angle of zero degrees. The analysis shows a maximum power coefficient of 0.35 at a tip speed ratio of 2.8 at 11 m/s winds. To calculate the annual energy production, the turbine was assumed to be operating at this point throughout its life cycle. This can be achieved through the active pitch control. A total turbine efficiency of 30% was assumed, taking into account the mechanical and electrical efficiencies as well as the coefficient of performance of the blade. The analysis was performed for Floyd County, VA where the test turbine could be placed for testing purposes and has an average wind speed of 7 m/s. A Rayleigh distribution was generated using the average wind speed to determine the probability of a particular wind speed, shown in Figure 10. From this, the estimated annual energy production of the test turbine was calculated as 72 kWh per year. More exact power production of the testing turbine is explained in the Testing Results of the Control System using a Simulink model of the whole system.

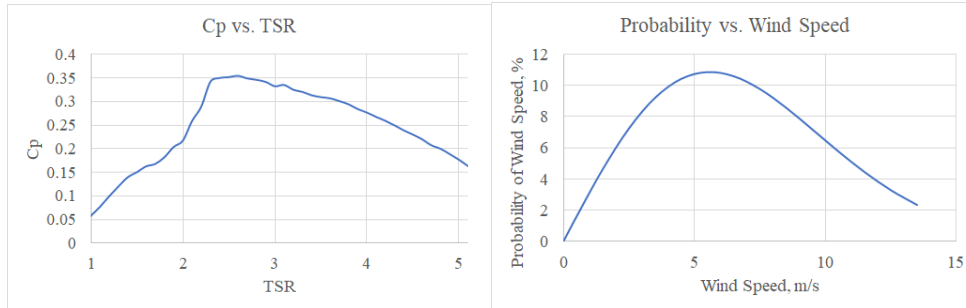

Figure 10: Cp vs TSR curve from QBlade (left) and Rayleigh estimated probability curve (right).

## Drive/Tower Design

The drive and tower design is the link between the blade and power electronic design. To ensure efficient power production of the wind turbine, a highly functional drivetrain was designed and built to properly convert the incoming rotational speed from the blades into usable electricity. For the tower design, the goal was to develop an effective support structure for all the components in the nacelle, while effectively yawing the turbine into the wind.

To ensure that both of these designs can withstand the ultimate loads on the turbine, a few initial calculations were conducted, for the power transmission that occurred along the drive shaft. The total power that can be produced by the blades will be converted into a torque and a RPM that will need to be transmitted through the drive shaft. This power transmission has a direct relationship to the power the drive shaft experiences. This is important to note because the losses through this transmission will need to be reduced as much as possible. By using a power balance, found in the simple loading model in the book titled *Small Wind Turbine: Analysis, Design, and Application* by David Wood [14], the power from the blades is set equal to the power of the drive shaft, shown in the following equation:

$$\frac{16}{27} \left( \frac{1}{2} \rho U_{\infty}^3 \right) (\pi R_{blades}^2) = \tau \left( \frac{\lambda U_{\infty}}{R_{Blades}} \right)$$

Where  $\rho$  is the air density,  $U_{\infty}$  is the wind speed,  $R$  is the radius of the blades,  $\tau$  is the torque (the goal of this power balance), and  $\lambda$  is the TSR or the tip speed ratio from the blades. The  $16/27$  term comes from a theoretical maximum Coefficient of Power produced from the blades. From the restrictions on maximum rotor area provided by the competition, the turbine can produce 40 Watts of power with a shaft rotating at 1400 RPM in 11 m/s winds. Based on these specifications and a TSR of 3, the max torque was calculated to be 0.33 N-m. Additionally, using the simple load model in accordance with IEC standard 61400-2 for small wind turbines, the maximum thrust load was calculated as 9.94 N. These calculations gives the team the needed numbers for all design decisions: maximum torque, maximum RPM, and maximum thrust.

## Drive Train

These calculations were accounted for in the drivetrain design, shown in Figure 11. The layout includes the (1) baseplate, (2) clamping flange mount shaft collar, (3) set-screw bearing, (4) static coupling, (5) the drive shaft, slip ring mount, generator mount, and the generator itself. The drivetrain components are further explained in the following section.

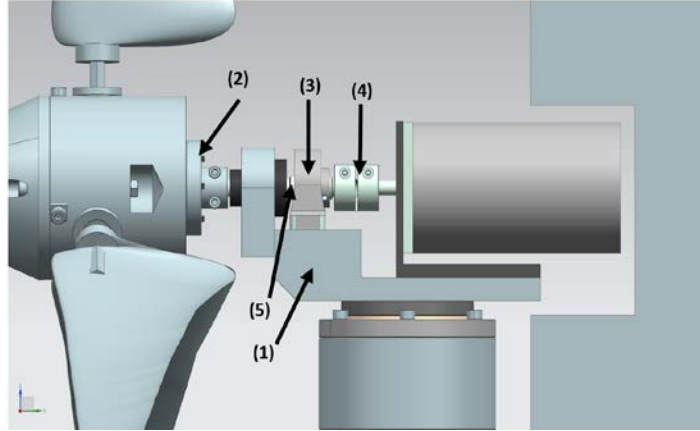

Figure 11: Computer Aided Design (CAD) model of the full layout of the drivetrain components.

(1) **Baseplate.** The function of the drive base plate, shown in Figure 12, is to support the drive system and ensure proper connection to the yaw bearing and tower. The baseplate was designed to be as short as possible, allowing the tail area to be maximized for yaw torque. The front of the baseplate is elevated so that the bearing can sit in line with the generator shaft. This will ensure that there is no misalignment between the generator shaft and the drive shaft.

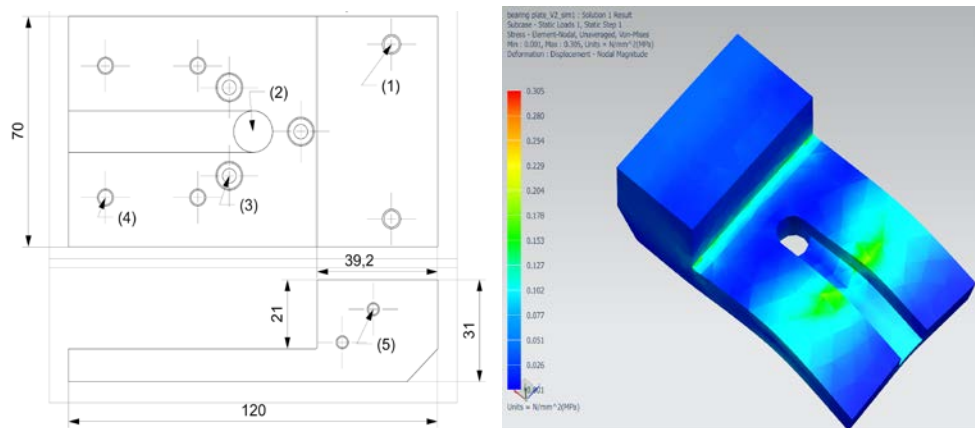

Figure 12: Drawing of the baseplate (left) and FEA stress analysis of the baseplate (right).

As shown in Figure 12, sitting on the drive baseplate are (1) a single set-screw type bearing, (2) thru hole for the wires to go down the tower, (3) holes for mounting the plate to the slewing bearing, (4) holes for the generator mount, and (5) holes to attach the nacelle. The drive baseplate was manufactured out of a single 6061 aluminum block that will be milled down to shape before bolt holes are drilled. By using this manufacturing method, we knew the generator and bearing heights were within the needed tolerance. Through calculations and a finite element analysis (FEA) for stresses, as shown in Figure 12, the team found that the safety factor for this component from forces from the blades and generator to be 707.

(2) **Shaft Collar.** The shaft-mount flange collar connects the hub to the shaft. The purpose of this collar is to effectively and efficiently transmit all of the torque provided by the blades into rotational energy through the drive shaft. Through testing in the Open Jet Wind Tunnel at Virginia Tech, and many iterations, this design was found to be the most effective way to transmit the torque. The drive shaft is attached to the collar via a key way and through the use of clamping force provided by the collar. This provides two different methods of torque transmission and the clamping will support the thrust that is expected from the blades, giving confidence in the maximum torque transmission from the blades to the shaft.

(3) **Bearing.** Through the initial concept generation, a system level design with two bearings supporting the drive shaft was decided. After testing this design in the Open Jet Wind Tunnel, it was found

that a two bearing design was unnecessary because of the existing generator bearing. The team decided on utilizing this generator bearing as one of the bearings for the drive train. This also allowed for a shorter drive shaft, giving maximized tail area for the largest moment arm from the yaw system. Ultimately, the one bearing design is very similar to the market turbine. After conducting research, ball bearings were selected given their ability to take both radial loads as well as some axial loads, especially when pre-assembled in a mount. The bearing chosen for our concept was a set-screw ball bearing pillow housing unit, fitting snugly to our drive shaft. While the housing is a Zinc Alloy Die Casting, the ball bearing itself is made of 52100 Steel, a standard material among ball bearings. The drive shaft was press-fit into the bearing as well as tightened with two set screws that are located at 90 degrees apart. This will ensure that the drive shaft is not slipping in the bearing unit. The structure and materials of this mounted bearing can support dynamic radial loads of up to 2000 N, which exceeds the weight of the blades (22.5 N), giving a safety factor of 95. The bearings can withstand a maximum speed of 43,000 RPM, giving a factor of safety of 21. Therefore, the bearing selected will confidently support the radial loads and maximum rotational speeds.

**(4 & 5) Static Coupling + Driveshaft.** To ensure a proper torque transmission and minimal alignment losses between the driveshaft and the generator shaft, a static coupling was chosen. The coupling has a rated RPM of 4000 as well as an allowable torque of 0.66 N-m. This equates to a torque safety factor of 2 and a RPM safety factor of 2.87. When designing the driveshaft, the main considerations were the loads due to wind, the weight of the hub system, and the rated RPM. The driveshaft is made out of a carbon steel, with an 8mm diameter for the smaller sides and 10mm diameter in the middle. The shaft is 69 mm in length, and modeled for a RPM of 2000. There is a keyway located on the hub end of the shaft for the flange collar.

Deflection resulting from mechanical loads was an important consideration in the design of the drivetrain, as high deflection can result in eccentricity of the system and can be a source of vibrations. A fatigue analysis was conducted on the shaft using *Shigley's Mechanical Engineering Design* book, and the reverse bending stress was found to be 0.268 MPa which is well below the endurance limit (475 MPa), meaning the drive shaft is designed for infinite life [13]. Additionally, using NX 11, a finite element analysis (FEA) simulation was conducted of our shaft to determine the maximum stress as well as the deflection. The setup for the FEA included a point load of 22.5 N at the hub side, a pin constraint at the bearing, and an axial displacement set to 0 at the coupling. From the FEA a maximum stress of 43.29 MPa was found in the sharp corner of the compression side in the bearing step. With a material yield strength of 620 MPa, the driveshaft has a safety factor of 14.32. As seen in Figure 13, the deflection was found to be 0.026 mm and was located at the end of the shaft. This end deflection was found to be negligible. The stress and deflection analyses ensure that the drive does transmit torque efficiently and is a minimal source of vibrations and mechanical losses.

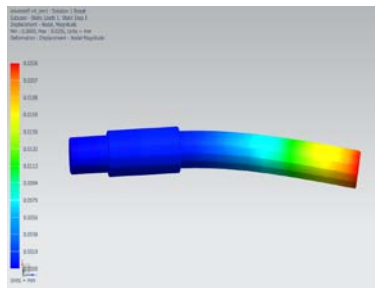

Figure 13: FEA deflection simulation of the driveshaft; deflection is exaggerated for effect.

### Yaw System

To achieve optimal performance of our wind turbine, we implemented a passive yaw system including a tail and a slewing bearing, which accommodates for the three translational and two rotational forces, only allowing rotation around the yaw axis. The forces experienced by the slewing bearing can be seen in Figure 14 and act in all directions when the turbine is yawing with changing wind direction. With a maximum permissible titling moment of 200 N-m, our bearing has a safety factor of 40 at 20 m/s winds

and has rotatory speed limit of about 171 degrees a second, making this slewing bearing assembly an ideal choice for our application.

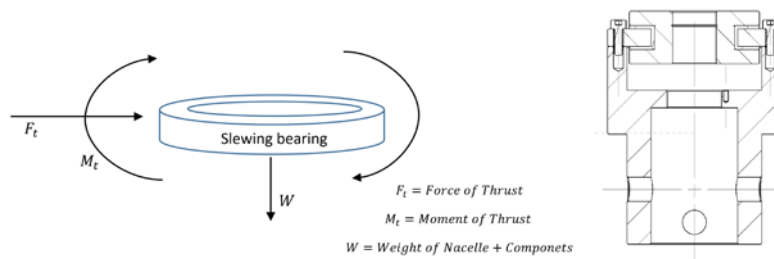

Figure 14: Free body diagram of the forces acting on the slewing bearing (left) and section view of yaw system (right).

Our yaw assembly, shown in Figure 14, is made up of a slewing bearing and a yaw adapter. From the baseplate, we have three bolts going through holes in the baseplate and through the inner ring of the slewing bearing and nutted down under the bearing. There are six screws around the perimeter of the outer ring of the slewing bearing that attach to the yaw adapter with tapped holes. The adapter has two through holes in the lower sides of it to accommodate for stability and a firm connection to the tower. This system allows our turbine to yaw effectively while compensating for additional forces.

As part of the turbine's passive yaw system, there will be an attached tail which will act to yaw the turbine back into the wind as needed. In order to achieve the yaw rate specified by the competition, a large surface area is desired by the tail in order to create the largest moment arm. Due to size constraints imposed, the tail is constrained to a height of 45 cm and a length of 18 cm which gives a maximum drag force of 2.11 N at a wind speed of 6 m/s when the turbine is facing perfectly out of the wind at 90°. The tail is to be mounted at two points on top of the nacelle, in order to minimize deformation and vibration of the tail. Fiberglass was chosen as the material for the tail because of its high strength to weight ratio and its ease of machinability. By modeling the fiberglass tail as a simple cantilever beam, the largest amount of deflection seen, at a maximum operating condition of 11 m/s, is 0.92 mm at the top corner. This is assuming a worst case scenario where the tail is oriented at 90° to the airflow and there is no yawing. Figure 15 shows the two connection points and FEA deflection, proving very minimal deflection.

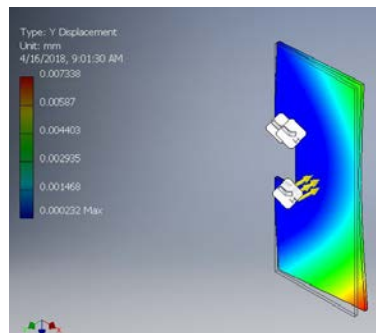

Figure 15: Tail connection and maximum deflection seen through FEA.

### Nacelle

The nacelle was designed to shield the drivetrain components while improving the overall aerodynamics of the system. On top back of the nacelle, there is a mount for the tail to be attached, which puts the front end of the tail as close as possible to the axis of yaw, allowing its area to be maximized, therefore maximizing the yaw torque that the tail can produce. The nacelle was manufactured using a 3D printer due to the complex shape and to keep it lightweight. A computational fluid dynamics simulation

was conducted in Siemens NX to ensure that the nacelle will provide smooth streamlines and minimal stagnation points across the turbine.

## Tower

The tower serves as the support structure for all of the components housed in the nacelle as well as the connection to the wind tunnel. Our design, constrained by the connection to the competition wind tunnel and the need for wires to run down the tower for power electronic, features a hollow 6061 Aluminum tube with an outer diameter of 38.1 mm and thickness of 6.35 mm. The tube does not have a taper, and allows enough space for the wires to pass through. Our team chose 6061 Aluminum as the material for both the tower and the tower baseplate. This decision was made because of Aluminum 6061's strength, durability, and ease of manufacturing.

Sizing of the tower was determined by performing a failure analysis of the expected loading. The primary loads on our tower are from thrust force, drag force and torque, as seen in Figure 16. The summation of these loads creates an overall moment at the base of the tower of 24.3 N-m. We used the geometry of the tower, and a concentration factor of 2 from the connection to the baseplate to calculate the stress to be 11.1 MPa. This calculated stress gives the tower a factor of safety of 21.7 when using Aluminum 6061, confirmed by a finite element analysis on Siemens NX seen in Figure 16. All of our failure analysis was considered using a wind speed of 20 m/s, the fastest wind our turbine will experience in the wind tunnel.

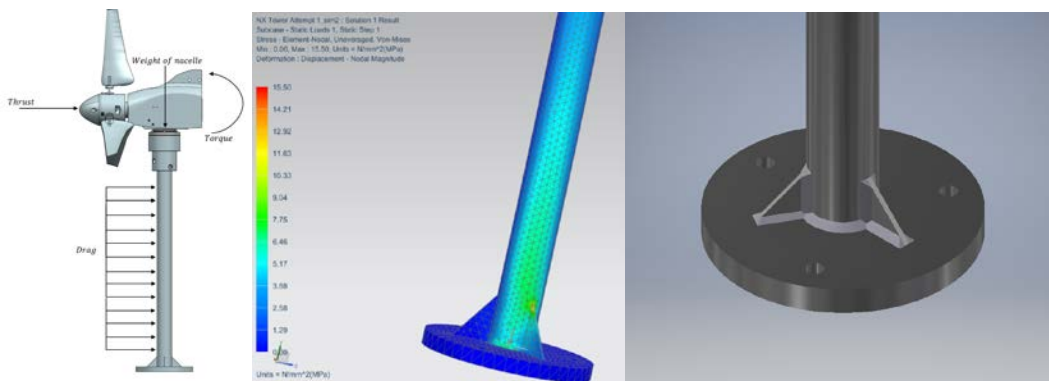

Figure 16: Forces acting on the tower and nacelle (left), FEA analysis (middle), and tower weld (right).

The tower is nested inside the hole in the baseplate and is welded together. Our team wanted the added strength that comes from using a flange, as well as the permanence and security that comes with a weld. To unite these elements, we decided to do a 'hybrid' connection by using small gussets for added support as shown in Figure 16.

## Electrical Design

The electrical design had a goal of implementing a system capable of excelling in the five competition tasks: Cut-In Wind Speed, Power Curve Performance, Control of Rated Power, Durability, and Safety. In order to do so the team focused on power maximization, system efficiency, robustness, and operational extremes when designing the system.

In order to design the system, mechanical power extracted from the wind, the rotational speed of the generator, and the mechanical torque applied to the generator needed to be calculated at 11 m/s wind speed. Using the equation and the calculations mentioned before in the Drive/Tower section, the rated mechanical power, mechanical torque, and rotational speed were calculated to be 40 W, 0.3 N-m, and 1400 RPM, respectively.

With the calculated values of power, torque, and speed, as well as the competition’s design constraints, the generator and power electronics system was appropriately designed. Figure 17 is the system schematic and contains the sections:

1. 3-Phase AC Generator with Internally Mounted Hall-Effect Sensors
2. 3-Phase Diode Bridge Rectifier
3. Measurements and Sensing
4. Electromagnetic Disconnect Relay
5. Ultracapacitor Charge-Discharge Circuit with Output Voltage Regulation
6. Pitch Control Stepper Motor and Driver System
7. Arduino Analog and Digital I/O Pins
8. Arduino Power Pins

Note: the locations of the pins in sections 6, 7, and 8 do not reflect the physical locations of the pins on the Arduino and the motor driver. The pin locations on the schematic were chosen to enhance readability.

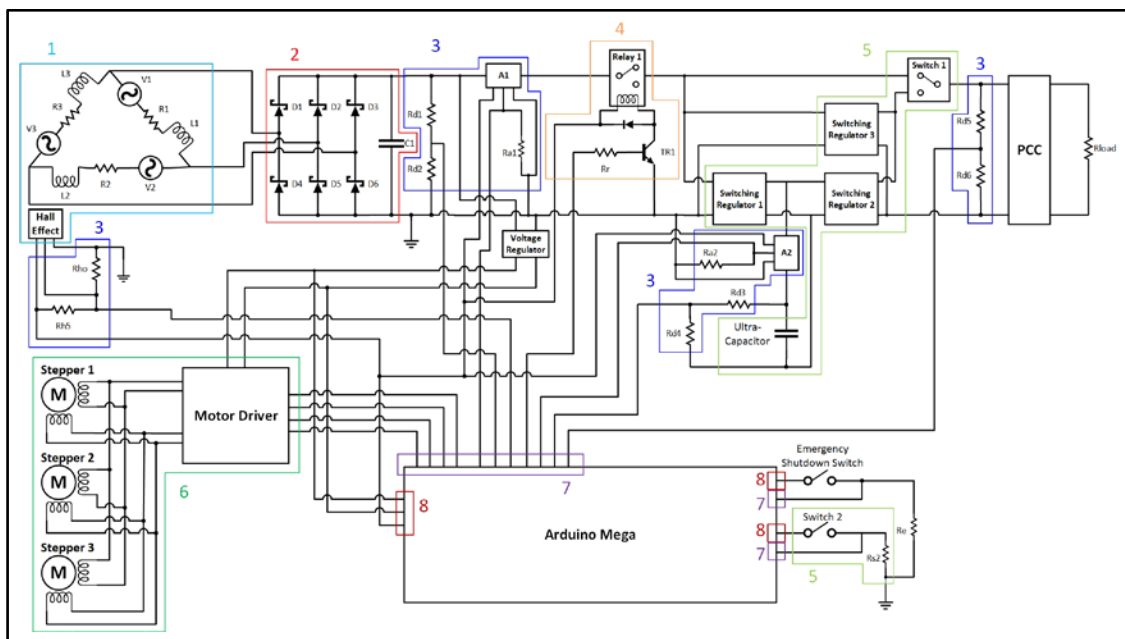

Figure 17: Generator and power electronics schematic.

### Generator

The team decided that a 3-phase permanent magnet inner-rotor brushless DC motor would be the ideal machine to use as the turbine’s generator. Brushless DC motors are designed similarly to 3-phase permanent magnet AC machines. Supplying the stator windings with an electronically commutated DC current produces a Lorenz-force torque on the rotor permanent magnets, causing the rotor to spin [2]. Applying this concept in reverse, mechanically driving the rotor induces 3-phase AC voltages in the stator windings, as is the case with a generator.

An added benefit of selecting a brushless DC motor is the internally mounted hall-effect sensors. When powered, these sensors produce an output voltage waveform over time that represents the position of the rotor. Additional details on the use of these sensors is included in the Measurements and Sensing section below.

Using the calculated values of 40 W, 1400 RPM, and 0.3 N-m, the team procured and tested three 3-phase permanent magnet inner-rotor brushless DC motors: a Moog BN28, a Bodine Electric 34B2BEBL, and an Anaheim Automation BLWS234S. The motors were tested using the diode bridge rectifier,



described later, and the load resistance that resulted in maximum power output. A decision matrix, as seen in Table 6 below, was used to determine the optimal motor. The five parameters in the matrix were given weights based on importance, and each generator was given a score from 1 to 5, with 1 being the worst and 5 being the best. The input torque characteristic was weighted the highest, because the blade design is optimal at 1400RPM. The input torque as a function of speed will determine the operating speed of the system at 11m/s wind. Hence, if the input torque characteristic is too high or too low, the system will not operate at the optimal rated speed. Max output power was weighted similarly to input torque, because producing the highest output power at rated speed will allow the system to excel in the Power Curve Performance and Durability tasks. It will also allow the turbine to produce enough power to operate the pitch control system at low RPMs, as is needed in the Safety task. The no-load output voltage characteristic is important, because a higher characteristic will allow the Arduino and the ultracapacitor switching regulators to turn on at lower RPMs. It is also important that the characteristic not be too high, in order to avoid exceeding the 48 V limit. The output current characteristic is proportional to the power loss through the system due to resistive components, and therefore, to overall efficiency. A lower output current characteristic is desirable. Lastly as mentioned above, a lighter generator is desirable for an optimal drive and tower design, but the design can be altered to fit the generator if needed. As seen in the matrix, the Anaheim Automation generator scored the highest, and was selected as the turbine generator. The team selected a constant resistive load of 21 ohms for the generator, discovered during wind tunnel testing and shown later in the report.

Table 6: Generator Decision Matrix

Parameter	Units	Weighting	Moog	Bodine	Anaheim
Input Torque Characteristic	N-m/k-rpm	35%	0.038 (1)	0.207 (5)	0.181 (4)
Max Output Power at Rated Speed	W	30%	7.58 (1)	33.4 (5)	31.59 (4)
No-Load Output Voltage	V/k-rpm	20%	4.71 (1)	7.14 (2)	21.92 (5)
Output Current Characteristic	A/k-rpm	10%	1.23 (5)	4.81 (1)	1.25 (5)
Weight	lb	5%	1.41 (5)	8.28 (1)	2.2 (5)
<b>Total Score</b>			1.6	3.8	4.35

### Diode Bridge Rectifier

The 3-phase AC voltages produced by the generator are rectified to a DC voltage using a 3-phase diode bridge rectifier consisting of six Schottky diodes and a set of parallel capacitors - represented by one equivalent capacitance in Figure 17.

The parallel capacitors were sized to reduce the amount of AC ripple at the output of the rectifier, which is present as a result of the switching action of the diodes. Increased capacitance further smooths the DC voltage by allowing for additional hold-up time due to higher energy storage capacity.

### Measurements and Sensing

The Arduino measures the voltages, currents, and RPM described in this section in order to perform its control operations, explained in the Control Design section below. The voltage across the rectifier, the

super capacitor, and the load is measured by stepping down these sensed voltages using voltage dividers consisting of resistors  $R_{d1}$  and  $R_{d2}$ ,  $R_{d3}$  and  $R_{d4}$ , and  $R_{d5}$  and  $R_{d6}$ , respectively. The Arduino then samples the voltages across  $R_{d2}$ ,  $R_{d4}$ , and  $R_{d6}$ . The dividers are sufficient for this sensing applications since the input resistance of the Arduino is high, and the resistor values are chosen such that their equivalent resistance is less than  $10\text{ k}\Omega$  to satisfy datasheet requirements.

The current out of the rectifier and into or out of the ultracapacitor is measured using Hall-effect current sensors and pull-down resistors  $A_1$  and  $R_{a1}$ , and  $A_2$  and  $R_{a2}$ , respectively. The Arduino samples the voltage output that the sensors provide, which is proportional to the magnetic field induced by the current through the sensor, and therefore, proportional to the current's magnitude. This method is preferable to using a shunt resistor, as the Hall-effect sensors do not add a resistive power loss.

To measure the rpm of the generator, one of the generator's Hall-Effect sensors, pull-up resistor  $R_{h5}$ , and pull-down resistor  $R_{ho}$  are used. The Arduino tracks the sensor's voltage output as a function of time as it oscillates between high and low states. Using the generator's timing diagram, the Arduino calculates the generator rpm.

### Electromagnetic Disconnect Relay

Electromagnetic Relay 1 is used to disconnect the load from the generator, and therefore preserves power for the Arduino and the pitch control system when necessary. To operate the relay, the Arduino provides  $5\text{V}$  to resistor  $R_r$ , which forward-active biases BJT TR1, allowing it to conduct current from the collector to the emitter. Current flows from the  $5\text{ V}$  Arduino pin through the relay coil and TR1, magnetizing the coil and switching the output of relay from the top load-connected pin to the bottom open-circuited pin.

### Ultracapacitor Charge-Discharge Circuit

As seen in Figure 17, three switching regulators, Switching Regulator 1, Switching Regulator 2, and Switching Regulator 3, are used to charge the competition-provided  $58\text{F}$  ultracapacitor and maintain a constant  $5\text{V}$  across the competition-provided variable load. Regulator 1 takes the variable DC rectifier voltage and charges the ultracapacitor with a constant output current until the ultracapacitor voltage reaches Regulator 1's DC output voltage set point. In order to safely charge the ultracapacitor, it is important that Regulator 1 has constant current capabilities. With a constant current output and a fixed capacitance, Regulator 1 forces the rate of change of the voltage across the capacitor to be constant. Without a constant current limit, the voltage across the capacitor would change rapidly, resulting in a large and potentially harmful inrush current into the capacitor. It is also important to note that Regulator 1 acts as an open-circuit when its input voltage is below its turn-on voltage, preventing unregulated charging of the ultracapacitor.

Regulators 2 and 3 regulate  $5\text{ V}$  at their output to ensure the desired voltage across the competition-provided load. The input of Regulator 2 is connected in parallel across the capacitor in order to draw upon the stored energy. The input of Regulator 3 is connected in parallel with the rectifier, so that regulated  $5\text{V}$  can be supplied to the load directly from the generator in the event that the voltage across the ultracapacitor is below the turn-on voltage of Regulator 2.

At the start of the durability task, a manual Switch 1 will be thrown to connect the load to the output of Switching Regulators 2 and 3. Manual Switch 2 will also be thrown to signal the Arduino to adjust its operation into durability task operation.

### Pitch Control Stepper Motor and Driver System

The pitch control system consists of three hybrid stepper motors connected in parallel and driven in unison by a bipolar stepper motor driver. The rotor of each stepper is connected to the spar of one the three blades. As coils A and B of the steppers are energized magnetic fields with north and south poles are created in the coils. The north and south poles of the stepper rotor magnets align to these magnetic poles, causing the rotor to turn and the blades' pitch angle to change. Power for the steppers is supplied by the

generator through the driver via a 9V buck/boost regulator, labeled Voltage Regulator in Figure 17. A signal consisting of four Arduino digital output pins controls the operation of the steppers through the driver.

### Arduino Analog and Digital I/O Pins and Power Pins

The analog input pins on the Arduino receive and sample the voltage outputs of the RPM, voltage, and current sensors, as well as the output states of the Emergency Shutdown Switch and Switch 2. The digital output pins are used for driving the relay and for sending signals to the stepper motor driver. The Arduino receives power from the 9V buck/boost regulator, which turns on at approximately 2.5 V. The Arduino provides 5 V to the two Hall-Effect current sensors, the generator Hall-Effect sensors, and the disconnect relay. It also supplies 3.3 V to the logic circuit of the stepper motor driver.

## Test Turbine: Control Design

To ensure that the aerodynamic, mechanical, and electrical designs all can function in unison and at optimal design conditions, two control designs were implemented: one from the power electronics and one from a Simulink model to simulate the dynamics of the system without physical testing.

### Power Electronics

The power electronics control system is used to minimize the cut-in wind speed, maximize the power output during the Power Curve-Performance and Durability tasks, regulate the power output during the Control of Rated Power task, and shutdown the turbine during the Safety task.

To perform these functions, an Arduino Mega 2560 is used to control the dynamic aspects of the system. As soon as the Arduino receives power from the generator, it enters a finite state machine, with states corresponding to the Cut-In Wind Speed, Power Curve Performance, Control of Rated Power, Safety, and Durability tasks. The finite state-machine and its transitions are summarized in Figure 18. Upon receiving power from the generator for the first time, the Arduino assumes that its blades are in cut-in position and will immediately move onto the next state. If the durability switch is off, then it enters the power curve performance state. During this state, the Arduino will use its known pitch angle and the measured rpm to determine the wind speed. If the Arduino determines that there is sufficient power available, it will adjust the blades to the optimal angle for that wind speed. Once the power output reaches the value of rated power, the Arduino will enter the Control of Rated Power state. In this state, it will use a PID control system to maintain a constant power output and constant RPM for wind speeds above 11 m/s. If the power drops below 90% of the rated power, the Arduino reverts back to the Power Curve state.

If at any point during its operation the Arduino detects either a load disconnect or the depression of the shutdown button, it will enter the Safety state. A load disconnect is determined by an approximately-zero measured current and a nonzero measured voltage at the output of the rectifier. In the safety state, the Arduino will use a PID control system to control RPM to 10% of the rated RPM while preserving power by disconnecting the load using electromagnetic Relay 1. Once the Arduino detects that the durability Switch 2 has been toggled, it will re-enter the Cut-In state to pitch blades to optimal cut-in, reconnect the relay, and enter the Durability state. In this state, the Arduino continually pitches the blades in the direction of a positive power output increase, eventually zeroing in on an optimal power position. When the Arduino detects that the durability switch has been toggled back, it will re-enter the Cut-In state, ready to repeat the process, if necessary.

### Overall System

A Simulink model, shown in Figure 19, was created to simulate the dynamic interaction between the blades and generator to aid in the design iteration, predict turbine performance, and test pitch control algorithms.

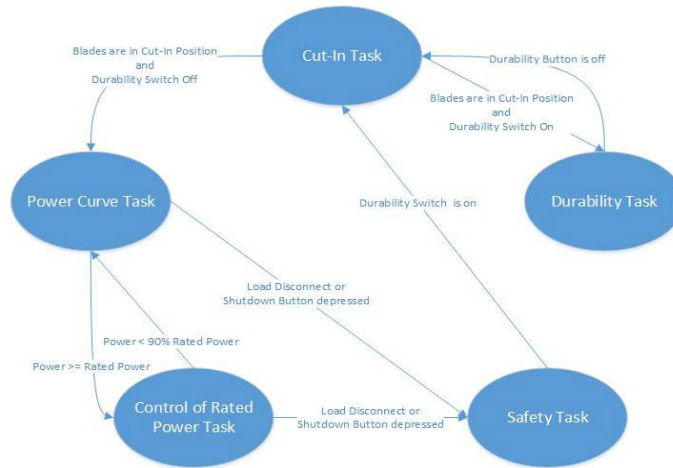

Figure 18: Arduino finite state machine design.

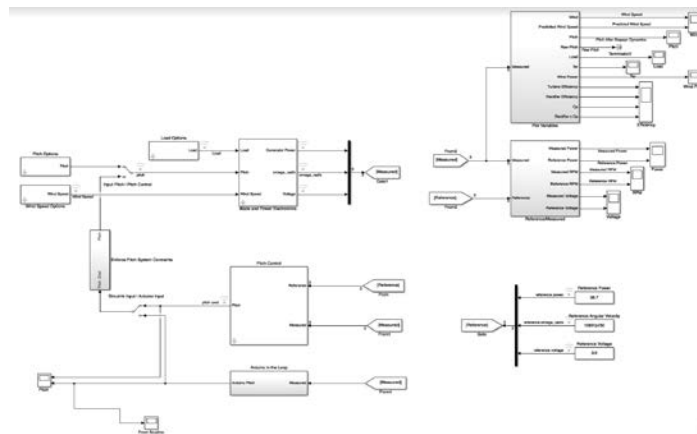

Figure 19: Simulink model of the overall wind turbine system.

The blades are simulated by interpolating tables of theoretical blade element momentum theory data. The model input is the tip speed ratio and pitch of the blades, and the output is the power, torque, and thrust produced by the blades. The generator is simulated by interpolating tables from generator testing. The generator model input is load and rpm applied to the generator and the output is the torque, power, and voltage created by the generator, taking into account rectifier efficiencies. The torque from the blades and the generator are used to determine the angular acceleration of the turbine and the new rpm.

Pitch control logic is simulated as well. The model is able to switch between maximizing the power using a look-up table and using a PID controller. The simulation can optionally communicate with an Arduino for hardware-in-the-loop simulations. The theoretical maximum rated power of the turbine is 41 watts at a pitch angle of 3 degrees, a wind speed of 11 m/s, and an RPM of 1600, shown in Figure 20.

## Testing Results

To ultimately ensure the design could perform similar to the theoretical calculations and withstand to the competition protocol, multiple areas of our turbine were tested: optimal load, power curve, cut-in, and yaw system.

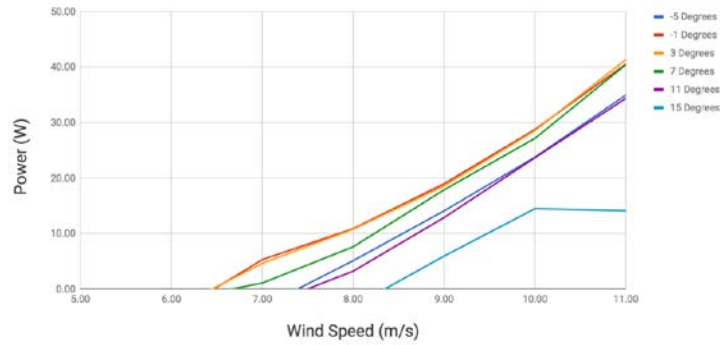

Figure 20: Theoretical power of the test wind turbine at 1600 RPM.

### Optimal Load

An optimal load for maximum power and minimized cut-in was needed with the power electronic design of a static load. The optimal constant-resistance load was determined by testing the power output of the turbine at 11 m/s wind as a function of load. This was performed in the Virginia Tech Open Jet Wind Tunnel. The blade pitch angle was set at the optimal power angle determined experimentally through multiple iterations. As shown in the results in Figure 21, the optimal load for the turbine was 21  $\Omega$ , producing 28.13 W.

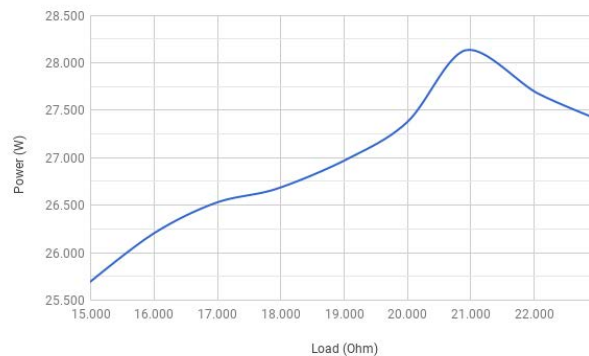

Figure 21: Optimal load testing at 11 m/s winds (generator power output as a function of load resistance).

### Power Curves and Cut-In

To fully characterize our turbine in multiple wind speeds, the team gathered power curves during testing in Virginia Tech’s Open Jet Wind Tunnel. The original plan was to use the pitch control system to iterate through pitch angles to various angles at each wind speed to find the maximum power produced at each wind speed. Due to issues with wiring during testing and testing time being too valuable to fix the wiring at the time, the team decided to manually pitch the blades to find the maximum power curve. The power curves with various pitch angles and the maximum power curve can be seen in Figure 22 (left). These various pitch positions, based on manually changing the angle, range from 8 to 37 degrees pitch. These pitch angles are slightly different compared to the expected due to the nature of manually pitching the angles without a true 0 degree reference angle. The final power curve, with active pitch control working, will be similar to Figure 22 (right) and the power will continue at approximately 28 W from 11 m/s to 20 m/s winds. At 11 m/s wind speed, the turbine spun at 1472 RPM and delivered 28.75 W at 23.00 V to the load. At 7 m/s wind speed, the turbine spun at 170 RPM and delivered 0.328 W at 2.52 V. This voltage output is significant because it has reached the turn-on voltage of the 9 V regulator. With the current system, the Arduino will perform its control functions at wind speeds greater than or equal to 7 m/s.

At optimal cut-in pitch, the turbine began to spin at 5.2 m/s. At this wind speed, the turbine spun at 52.5 RPM and delivered 0.0104 W at 0.52 V to the load. The team hopes to improve cut-in by taking material off of the 3D printed hub, having more accurate pitching to allow for the ideal aerodynamic properties for the cut-in scenario, and find an improved slip-ring to reduce cogging torque in the system.

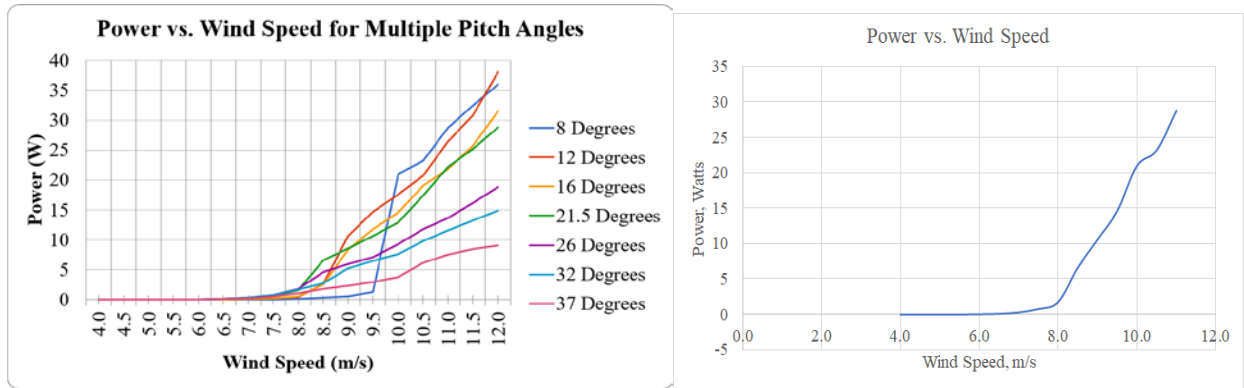

Figure 22: Left: Power output at various wind speeds and pitch angles. Right: Maximum power output at each wind speed.

## Yaw System

To ensure the yaw system could keep the turbine aligned directly into the wind during the durability task, the turbine was placed on a turntable at 6 m/s winds. From this testing, it was determined that a moment of 0.1 N-m is required to overcome the internal resistance of the yaw bearing and initiate yawing rotation. In order to achieve a yaw rate of  $180^\circ/\text{second}$ , a net moment of about 0.2 N-m must be applied by the tail. It is important to note that this is the net moment applied to the yaw bearing, not the moment from the tail alone, meaning the tail must be able to overcome the counter moment produced by the components on the other side of the yaw bearing from the tail. The net moment from drag produced by the tail and the rest of the turbine components was 0.19 N-m, which is just below our target of 0.2 N-m. A turn table was created to mock the CWC competition of a yaw rate of  $180^\circ/\text{second}$ . The yaw system was then tested on this turntable in the Open Jet Wind Tunnel at Virginia Tech. At wind speeds of 6m/s the turbine was able to yaw back into the wind without the blades stopping when  $180^\circ/\text{second}$  was applied to the base of the turbine. The yaw system was even more effective at speeds of 11 m/s; the turbine stayed aligned to the wind within +/- 20 degrees during the 11 m/s wind test.

## References

1. DatacenterDynamics. (2007, September 19). New study examines impact of power outages on data center. Retrieved from <http://www.datacenterdynamics.com/new-study-examines-impact-of-power-outages-on-data-center/54861.fullarticle>
2. Electrical Technology. (2018). *Brushless DC Motor: Construction, Working Principle & Applications*. (2018). *Electrical Technology*. Retrieved 15 April 2018, from <https://www.electricaltechnology.org/2016/05/bldc-brushless-dc-motor-construction-working-principle.html>
3. Freedman, A. (2014, September 30). There Are Now 3 Million Data Centers in the U.S., and Climbing. Retrieved April 22, 2018, from <https://mashable.com/2014/09/30/does-energy-efficiency/#b1RCNHoUouq0>
4. Ganeshalingam, M., Shehabi, A., Desroches, L.B., (June 2017). *Energy Analysis and Environmental Impacts Division. Shining a Light on Small Data Centers in the U.S.* Retrieved from <https://eta.lbl.gov/sites/default/files/publications/lbnl-2001025.pdf>
5. Hu, X. (2018). *An Introduction to Stepper Motors*. Retrieved 15 April 2018, from [https://wp.optics.arizona.edu/optomech/wp-content/uploads/sites/53/2016/10/Tutorial\\_Xinda-Hu.pdf](https://wp.optics.arizona.edu/optomech/wp-content/uploads/sites/53/2016/10/Tutorial_Xinda-Hu.pdf)
6. McMaster-Carr. (n.d.). Retrieved from <https://www.mcmaster.com/> Part Number: 9723T12
7. Shehabi, A., Smith, S. J., Sartor, D. A., Brown, R. E., Herrlin, M., Koomney, J. G., . . . William. (2016, June). United States Data Center Energy Usage Report. Retrieved April 22, 2018, from <https://eta.lbl.gov/publications/united-states-data-center-energy>
8. Shigley, J. E. (2016). *Shigley's Mechanical engineering design*. New York: McGraw-Hill.
9. U.S. Energy Information Administration - EIA - Independent Statistics and Analysis. (n.d.). Retrieved from [https://www.eia.gov/electricity/monthly/epm\\_table\\_grapher.php?t=epmt\\_5\\_6\\_a](https://www.eia.gov/electricity/monthly/epm_table_grapher.php?t=epmt_5_6_a)
10. What does the capacity factor of wind mean? (n.d.). Retrieved from <http://energynumbers.info/capacity-factor-of-wind>
11. What is a data center? (n.d.). Retrieved April 22, 2018, from <https://www.paloaltonetworks.com/cyberpedia/what-is-a-data-center>
12. Wind Energy in Connecticut. (n.d.). Retrieved from <https://windexchange.energy.gov/states/ct>
13. Wood, D. (2011). *Small Wind Turbines* (p. 2). London: Springer.
14. Wood, D. H. (2013). *Small Wind Turbines: Analysis, design and application*. London: Springer.